

Preliminary Environmental Assessment

**Santiam-Bethel Transmission Line Project**

Bonneville Power Administration

**September 2001**

## Santiam-Bethel Transmission Line Project

**Responsible Agency:** U.S. Department of Energy, Bonneville Power Administration (BPA)

**Name of Proposed Project:** Santiam–Bethel Transmission Line Project

**Abstract:** Bonneville Power Administration proposes to rebuild the first 17 miles of the Santiam-Chemawa transmission line from Santiam Substation to the line’s connection to Portland General Electric’s Bethel Substation. BPA would replace the existing single-circuit 230-kilovolt (kV) line with towers that could support two circuits. The existing line supplies both Bethel Substation and BPA’s Chemawa Substation. The new lines would eliminate overloading of the existing line from Santiam Substation to the line’s connection to Bethel Substation by having one new line supply Bethel Substation and the other new line supply Chemawa Substation.

In addition to the Proposed Action, BPA is considering the No Action Alternative. In the No Action Alternative, BPA would not upgrade or rebuild the line. The existing line would remain in operation.

The environmental analysis determined that the Proposed Action would have no significant impacts. There would be short-term, construction-related impacts such as noise, dust, vegetation disturbance, soil compaction and erosion. The proposed new double-circuit towers would be more visible than the existing towers. Some existing trees would be removed.

In the No Action Alternative, normal and extreme cold winter load conditions could cause thermal overloading of existing facilities and potential curtailment of electrical power in the area. Impacts associated with maintenance of the existing line would continue.

For additional information, contact:  
Tish Levesque, Environmental Project Lead  
Bonneville Power Administration  
P.O. Box 3621 – KEC-4  
Portland, Oregon 97208-3297  
Telephone: (503) 230-3469, or  
toll free 1-800-282-3713  
Email: [tklevesque@bpa.gov](mailto:tklevesque@bpa.gov)

To submit comments, write or call:  
Bonneville Power Administration  
Communications Office – KC-7  
P.O. Box 12999  
Portland, Oregon 97212  
Telephone: (800) 622-4519  
Fax: (503) 230-3285  
Email: [comment@bpa.gov](mailto:comment@bpa.gov)

For more copies of this document, call (800) 622-4250 and ask for the document by name. The document is also available at the BPA, Environment, Fish and Wildlife Home Page: [www.efw.bpa.gov/cgi-bin/PSA/NEPA/SUMMARIES/Santiam-BethelTransmissionLine](http://www.efw.bpa.gov/cgi-bin/PSA/NEPA/SUMMARIES/Santiam-BethelTransmissionLine).

For additional information on DOE NEPA activities, please contact: Carol Borgstrom, Director, Office of NEPA Policy and Compliance, EH-42, U.S. Department of Energy, 1000 Independence Avenue S.W., Washington, D.C. 20585; (800) 472-2756.

**Table of Contents**

- 1.0 Need for and Purpose of Action ..... 1
  - 1.1 Introduction..... 1
  - 1.2 Underlying Need for Action ..... 1
  - 1.3 Purposes..... 2
  - 1.4 Public Involvement..... 2
- 2.0 Proposed Action and Alternatives ..... 3
  - 2.1 Proposed Action..... 3
  - 2.2 No Action Alternative..... 3
  - 2.3 Alternatives Eliminated from Consideration ..... 4
    - 2.3.1 Construct a New Single-Circuit Line ..... 4
    - 2.3.2 Reconnector the Single-Circuit Line..... 4
    - 2.3.3 Conservation..... 4
    - 2.3.4 Building an Underground Transmission Line ..... 4
  - 2.4 Comparison of Alternatives..... 6
- 3.0 Affected Environment and Environmental Impacts ..... 9
  - 3.1 Land Use..... 9
    - 3.1.1 Affected Environment ..... 9
    - 3.1.2 Potential Impacts of the Proposed Action ..... 9
    - 3.1.3 Potential Impacts of the No Action Alternative ..... 12
    - 3.1.4 Cumulative Impacts..... 12
    - 3.1.5 Mitigation for the Proposed Action..... 13
  - 3.2 Socioeconomics ..... 13
    - 3.2.1 Affected Environment ..... 13
    - 3.2.2 Potential Impacts of the Proposed Action ..... 14
    - 3.2.3 Potential Impacts of the No Action Alternative ..... 15
    - 3.2.4 Cumulative Impacts..... 15
    - 3.2.5 Mitigation for the Proposed Action..... 15
  - 3.3 Visual Resources ..... 15
    - 3.3.1 Affected Environment ..... 16
    - 3.3.2 Potential Impacts of the Proposed Action ..... 17
    - 3.3.3 Potential Impacts of the No Action Alternative ..... 17

3.3.4 Cumulative Impacts.....	17
3.4 Recreation .....	18
3.4.1 Affected Environment .....	18
3.4.2 Potential Impacts of the Proposed Action .....	18
3.4.3 Potential Impacts of the No Action Alternative .....	18
3.4.4 Cumulative Impacts.....	18
3.5 Soils and Geology.....	18
3.5.1 Affected Environment .....	18
3.5.2 Potential Impacts of the Proposed Action .....	19
3.5.3 Potential Impacts of the No Action Alternative .....	19
3.5.4 Cumulative Impacts.....	19
3.5.5 Mitigation for the Proposed Action.....	19
3.6 Vegetation.....	20
3.6.1 Affected Environment .....	20
3.6.2 Potential Impacts of the Proposed Action .....	20
3.6.3 Potential Impacts of the No Action Alternative .....	21
3.6.4 Threatened and Endangered Species .....	21
3.6.5 Cumulative Impacts.....	21
3.6.6 Mitigation for the Proposed Action.....	21
3.7 Fish and Wildlife .....	22
3.7.1 Affected Environment .....	22
3.7.2 Potential Impacts of the Proposed Action .....	23
3.7.3 Potential Impacts of the No Action Alternative .....	24
3.7.4 Threatened and Endangered Species .....	24
3.7.5 Cumulative Impacts.....	26
3.7.6 Mitigation for the Proposed Action.....	26
3.8 Wetlands .....	27
3.8.1 Affected Environment .....	27
3.8.2 Potential Impacts of the Proposed Action .....	28
3.8.3 Potential Impacts of the No Action Alternative .....	28
3.8.4 Cumulative Impacts.....	28
3.8.5 Mitigation for the Proposed Action.....	28
3.9 Floodplains .....	29

3.9.1	Affected Environment .....	29
3.9.2	Potential Impacts of the Proposed Action .....	29
3.9.3	Potential Impacts of the No Action Alternative .....	29
3.9.4	Cumulative Impacts.....	29
3.9.5	Mitigation for the Proposed Action.....	29
3.10	Water Quality.....	30
3.10.1	Affected Environment .....	30
3.10.2	Potential Impacts of the Proposed Action .....	30
3.10.3	Potential Impacts of the No Action Alternative .....	31
3.10.4	Cumulative Impacts.....	31
3.10.5	Mitigation for the Proposed Action.....	31
3.11	Cultural Resources.....	31
3.11.1	Affected Environment .....	31
3.11.2	Potential Impacts of the Proposed Action .....	32
3.11.3	Potential Impacts of the No Action Alternative .....	32
3.11.4	Cumulative Impacts.....	32
3.11.5	Mitigation for the Proposed Action.....	32
3.12	Public Health and Safety .....	33
3.12.1	Exposure to Electric and Magnetic Fields.....	33
3.12.2	Electric and Magnetic Field Effects .....	34
3.12.3	Noise and Radio/Television Interference .....	36
3.12.4	Fire.....	37
3.12.5	Potential Impacts of the No Action Alternative .....	37
3.12.6	Mitigation for the Proposed Action.....	37
4.0	Environmental Consultation, Review, and Permit Requirements .....	39
4.1	National Environmental Policy Act.....	39
4.2	Threatened and Endangered Species .....	39
4.3	Fish and Wildlife Conservation .....	41
4.3.1	Essential Fish Habitat .....	41
4.3.2	Migratory Bird Treaty Act .....	41
4.4	Cultural and Historical Resources .....	42
4.4.1	National Historic Preservation Act.....	42
4.4.2	Archaeological Resources Protection Act.....	42

4.4.3	American Indian Religious Freedom Act.....	42
4.4.4	Historic Sites Act.....	42
4.4.3	Native American Graves Protection and Repatriation Act .....	43
4.5	State, Areawide, and Local Plan and Program Consistency.....	43
4.6	Floodplains and Wetlands Protection .....	43
4.6.1	Floodplain/Wetland Assessment .....	43
4.7	Farmland Protection Policy Act.....	43
4.8	Discharge Permits under the Clean Water Act.....	44
4.8.1	Federal .....	44
4.8.2	State .....	44
4.9	Permits for Structures in Navigable Waters .....	45
4.10	Noise Control Act.....	45
4.11	Global Warming .....	45
4.12	Executive Order on Environmental Justice .....	45
4.13	Resource Conservation and Recovery Act .....	45
4.14	State Agency Authorities and Regulations .....	45
4.15	Safe Drinking Water Act .....	46
4.16	Federal Insecticide, Fungicide, and Rodenticide Act .....	46
4.17	Toxic Substances Control Act .....	46
4.18	Clean Air Act.....	46
4.19	Permits for Rights-of-Way on Public Lands .....	46
4.20	Energy Conservation at Federal Facilities.....	46
4.21	Notice to the Federal Aviation Administration .....	47
5.0	Persons and Agencies Consulted.....	49
5.1	Federal Agencies .....	49
5.2	State Agencies .....	49
5.3	Local Agencies .....	49
5.4	Tribes .....	49
5.5	Utilities .....	49
5.6	Landowners.....	49
6.0	References .....	51
7.0	Glossary and Acronyms .....	55

Appendices

Appendix A-Electrical Effects

Appendix B-Assessment of Research Regarding EMF and Health and Environmental Effects

List of Maps, Figures and Tables

Map 1 - Santiam-Bethel Transmission Line Project ..... follows page 2

Figure 1- Existing and Proposed Structures..... 5

Table 1 - Summary of Impacts..... 7

Table 2 - Federally-Listed Species ..... 22

Table 3 - Federally-Listed Species ..... 25





SEPTEMBER 2001

# SANTIAM-BETHEL TRANSMISSION LINE PROJECT

Preliminary Environmental Assessment  
DOE/EA-1366



Preliminary Environmental Assessment

**Santiam-Bethel Transmission Line Project**

Bonneville Power Administration

**September 2001**

## Santiam-Bethel Transmission Line Project

**Responsible Agency:** U.S. Department of Energy, Bonneville Power Administration (BPA)

**Name of Proposed Project:** Santiam–Bethel Transmission Line Project

**Abstract:** Bonneville Power Administration proposes to rebuild the first 17 miles of the Santiam-Chemawa transmission line from Santiam Substation to the line’s connection to Portland General Electric’s Bethel Substation. BPA would replace the existing single-circuit 230-kilovolt (kV) line with towers that could support two circuits. The existing line supplies both Bethel Substation and BPA’s Chemawa Substation. The new lines would eliminate overloading of the existing line from Santiam Substation to the line’s connection to Bethel Substation by having one new line supply Bethel Substation and the other new line supply Chemawa Substation.

In addition to the Proposed Action, BPA is considering the No Action Alternative. In the No Action Alternative, BPA would not upgrade or rebuild the line. The existing line would remain in operation.

The environmental analysis determined that the Proposed Action would have no significant impacts. There would be short-term, construction-related impacts such as noise, dust, vegetation disturbance, soil compaction and erosion. The proposed new double-circuit towers would be more visible than the existing towers. Some existing trees would be removed.

In the No Action Alternative, normal and extreme cold winter load conditions could cause thermal overloading of existing facilities and potential curtailment of electrical power in the area. Impacts associated with maintenance of the existing line would continue.

For additional information, contact:  
Tish Levesque, Environmental Project Lead  
Bonneville Power Administration  
P.O. Box 3621 – KEC-4  
Portland, Oregon 97208-3297  
Telephone: (503) 230-3469, or  
toll free 1-800-282-3713  
Email: [tklevesque@bpa.gov](mailto:tklevesque@bpa.gov)

To submit comments, write or call:  
Bonneville Power Administration  
Communications Office – KC-7  
P.O. Box 12999  
Portland, Oregon 97212  
Telephone: (800) 622-4519  
Fax: (503) 230-3285  
Email: [comment@bpa.gov](mailto:comment@bpa.gov)

For more copies of this document, call (800) 622-4250 and ask for the document by name. The document is also available at the BPA, Environment, Fish and Wildlife Home Page: [www.efw.bpa.gov/cgi-bin/PSA/NEPA/SUMMARIES/Santiam-BethelTransmissionLine](http://www.efw.bpa.gov/cgi-bin/PSA/NEPA/SUMMARIES/Santiam-BethelTransmissionLine).

For additional information on DOE NEPA activities, please contact: Carol Borgstrom, Director, Office of NEPA Policy and Compliance, EH-42, U.S. Department of Energy, 1000 Independence Avenue S.W., Washington, D.C. 20585; (800) 472-2756.

**Table of Contents**

- 1.0 Need for and Purpose of Action ..... 1
  - 1.1 Introduction..... 1
  - 1.2 Underlying Need for Action ..... 1
  - 1.3 Purposes..... 2
  - 1.4 Public Involvement..... 2
- 2.0 Proposed Action and Alternatives ..... 3
  - 2.1 Proposed Action..... 3
  - 2.2 No Action Alternative..... 3
  - 2.3 Alternatives Eliminated from Consideration ..... 4
    - 2.3.1 Construct a New Single-Circuit Line ..... 4
    - 2.3.2 Reconnector the Single-Circuit Line..... 4
    - 2.3.3 Conservation..... 4
    - 2.3.4 Building an Underground Transmission Line ..... 4
  - 2.4 Comparison of Alternatives..... 6
- 3.0 Affected Environment and Environmental Impacts ..... 9
  - 3.1 Land Use..... 9
    - 3.1.1 Affected Environment ..... 9
    - 3.1.2 Potential Impacts of the Proposed Action ..... 9
    - 3.1.3 Potential Impacts of the No Action Alternative ..... 12
    - 3.1.4 Cumulative Impacts..... 12
    - 3.1.5 Mitigation for the Proposed Action..... 13
  - 3.2 Socioeconomics ..... 13
    - 3.2.1 Affected Environment ..... 13
    - 3.2.2 Potential Impacts of the Proposed Action ..... 14
    - 3.2.3 Potential Impacts of the No Action Alternative ..... 15
    - 3.2.4 Cumulative Impacts..... 15
    - 3.2.5 Mitigation for the Proposed Action..... 15
  - 3.3 Visual Resources ..... 15
    - 3.3.1 Affected Environment ..... 16
    - 3.3.2 Potential Impacts of the Proposed Action ..... 17
    - 3.3.3 Potential Impacts of the No Action Alternative ..... 17

3.3.4 Cumulative Impacts.....	17
3.4 Recreation .....	18
3.4.1 Affected Environment .....	18
3.4.2 Potential Impacts of the Proposed Action .....	18
3.4.3 Potential Impacts of the No Action Alternative .....	18
3.4.4 Cumulative Impacts.....	18
3.5 Soils and Geology.....	18
3.5.1 Affected Environment .....	18
3.5.2 Potential Impacts of the Proposed Action .....	19
3.5.3 Potential Impacts of the No Action Alternative .....	19
3.5.4 Cumulative Impacts.....	19
3.5.5 Mitigation for the Proposed Action.....	19
3.6 Vegetation.....	20
3.6.1 Affected Environment .....	20
3.6.2 Potential Impacts of the Proposed Action .....	20
3.6.3 Potential Impacts of the No Action Alternative .....	21
3.6.4 Threatened and Endangered Species .....	21
3.6.5 Cumulative Impacts.....	21
3.6.6 Mitigation for the Proposed Action.....	21
3.7 Fish and Wildlife .....	22
3.7.1 Affected Environment .....	22
3.7.2 Potential Impacts of the Proposed Action .....	23
3.7.3 Potential Impacts of the No Action Alternative .....	24
3.7.4 Threatened and Endangered Species .....	24
3.7.5 Cumulative Impacts.....	26
3.7.6 Mitigation for the Proposed Action.....	26
3.8 Wetlands .....	27
3.8.1 Affected Environment .....	27
3.8.2 Potential Impacts of the Proposed Action .....	28
3.8.3 Potential Impacts of the No Action Alternative .....	28
3.8.4 Cumulative Impacts.....	28
3.8.5 Mitigation for the Proposed Action.....	28
3.9 Floodplains .....	29

3.9.1	Affected Environment .....	29
3.9.2	Potential Impacts of the Proposed Action .....	29
3.9.3	Potential Impacts of the No Action Alternative .....	29
3.9.4	Cumulative Impacts.....	29
3.9.5	Mitigation for the Proposed Action.....	29
3.10	Water Quality.....	30
3.10.1	Affected Environment .....	30
3.10.2	Potential Impacts of the Proposed Action .....	30
3.10.3	Potential Impacts of the No Action Alternative .....	31
3.10.4	Cumulative Impacts.....	31
3.10.5	Mitigation for the Proposed Action.....	31
3.11	Cultural Resources.....	31
3.11.1	Affected Environment .....	31
3.11.2	Potential Impacts of the Proposed Action .....	32
3.11.3	Potential Impacts of the No Action Alternative .....	32
3.11.4	Cumulative Impacts.....	32
3.11.5	Mitigation for the Proposed Action.....	32
3.12	Public Health and Safety .....	33
3.12.1	Exposure to Electric and Magnetic Fields.....	33
3.12.2	Electric and Magnetic Field Effects .....	34
3.12.3	Noise and Radio/Television Interference .....	36
3.12.4	Fire.....	37
3.12.5	Potential Impacts of the No Action Alternative .....	37
3.12.6	Mitigation for the Proposed Action.....	37
4.0	Environmental Consultation, Review, and Permit Requirements .....	39
4.1	National Environmental Policy Act.....	39
4.2	Threatened and Endangered Species .....	39
4.3	Fish and Wildlife Conservation .....	41
4.3.1	Essential Fish Habitat .....	41
4.3.2	Migratory Bird Treaty Act .....	41
4.4	Cultural and Historical Resources .....	42
4.4.1	National Historic Preservation Act.....	42
4.4.2	Archaeological Resources Protection Act.....	42

4.4.3	American Indian Religious Freedom Act.....	42
4.4.4	Historic Sites Act.....	42
4.4.3	Native American Graves Protection and Repatriation Act .....	43
4.5	State, Areawide, and Local Plan and Program Consistency.....	43
4.6	Floodplains and Wetlands Protection .....	43
4.6.1	Floodplain/Wetland Assessment .....	43
4.7	Farmland Protection Policy Act.....	43
4.8	Discharge Permits under the Clean Water Act.....	44
4.8.1	Federal .....	44
4.8.2	State .....	44
4.9	Permits for Structures in Navigable Waters .....	45
4.10	Noise Control Act.....	45
4.11	Global Warming .....	45
4.12	Executive Order on Environmental Justice .....	45
4.13	Resource Conservation and Recovery Act .....	45
4.14	State Agency Authorities and Regulations .....	45
4.15	Safe Drinking Water Act .....	46
4.16	Federal Insecticide, Fungicide, and Rodenticide Act.....	46
4.17	Toxic Substances Control Act .....	46
4.18	Clean Air Act.....	46
4.19	Permits for Rights-of-Way on Public Lands .....	46
4.20	Energy Conservation at Federal Facilities.....	46
4.21	Notice to the Federal Aviation Administration .....	47
5.0	Persons and Agencies Consulted.....	49
5.1	Federal Agencies .....	49
5.2	State Agencies .....	49
5.3	Local Agencies .....	49
5.4	Tribes .....	49
5.5	Utilities .....	49
5.6	Landowners.....	49
6.0	References .....	51
7.0	Glossary and Acronyms .....	55

Appendices

Appendix A-Electrical Effects

Appendix B-Assessment of Research Regarding EMF and Health and Environmental Effects

List of Maps, Figures and Tables

Map 1 - Santiam-Bethel Transmission Line Project ..... follows page 2

Figure 1- Existing and Proposed Structures..... 5

Table 1 - Summary of Impacts..... 7

Table 2 - Federally-Listed Species ..... 22

Table 3 - Federally-Listed Species ..... 25







## Department of Energy

Bonneville Power Administration  
P.O. Box 3621  
Portland, Oregon 97208-3621

January 30, 2002

### **To: People Interested in the Santiam-Bethel Transmission Line Project**

In September 2001, Bonneville Power Administration (BPA) prepared a Preliminary Environmental Assessment (EA) for the Santiam-Bethel Transmission Line Project. You were on our mailing list to receive a copy. Since only two comments were received and only minor changes were needed on the Preliminary EA, it will serve as the Final EA and a separate document will not be issued. An errata sheet listing seven changes, a Finding of No Significant Impact, and a Mitigation Action Plan have been prepared and are enclosed.

**Additional Copies:** If you would like a copy of the EA, or additional copies of the enclosed errata sheet, Finding of No Significant Impact, and/or Mitigation Action Plan, please call our toll-free document request line: 1-800-622-4520. Leave a message naming this project and the documents you wish and giving your complete mailing address. They are also available at our website: [www.efw.bpa.gov](http://www.efw.bpa.gov).

**Proposal:** BPA proposes to rebuild the first 17 miles of the Santiam-Chemawa transmission line from Santiam Substation to the line's connection to Portland General Electric's Bethel Substation to improve transmission system reliability in the Salem area of northwestern Oregon. BPA would replace the existing single-circuit 230-kilovolt line with towers that could support two circuits (double-circuit) in the existing right-of-way. The existing line supplies both Bethel Substation and BPA's Chemawa Substation. The new lines would eliminate overloading of the existing line from Santiam Substation to the tap to Bethel Substation by having one new line supply Bethel Substation and the other new line supply Chemawa Substation.

**For More Information:** If you need more information or have any questions, please call me at my direct number, 503-230-3469, or toll-free at 1-800-282-3713; or e-mail me at [tklevesque@bpa.gov](mailto:tklevesque@bpa.gov). Thank you for your interest in our work.

*/s/ Tish Levesque*

Tish Levesque  
Environmental Project Manager

- 3 Enclosures:
1. Errata Sheet
  2. Finding of No Significant Impact
  3. Mitigation Action Plan

**ERRATA SHEET FOR  
SANTIAM-BETHEL TRANSMISSION LINE PROJECT  
FINAL ENVIRONMENTAL ASSESSMENT  
DOE/EA-1366**

January 28, 2002

This errata sheet documents the changes to be incorporated into the Preliminary EA named above. With these changes, the Preliminary EA will serve as the Final EA.

1. Add the following sections to the Table of Contents – “4.5.1 Coastal Zone Management Act Consistency,” “4.5.2 Oregon State Law,” “4.5.3 Linn County Comprehensive Plans and Development Code,” and “4.5.4 Marion County Comprehensive Plans and Ordinances.”
2. Section 3.7.6, page 26 – Add the following sentence after the first sentence of the second paragraph. “No construction activities would occur within 75 feet of surface waters if practicable.”
3. Section 3.7.6, page 26 – Under the paragraph that begins “To avoid the delivery...,” change the third sentence of the second bullet to read: “In areas where towers are adjacent to waterways (miles 3, 5, 7, 8, 9, 10, 11, 12, and 14), special erosion...”
4. Section 3.10.5, page 31 – Add the following bullet after the first bullet: “Refueling of vehicles would occur at least 400 feet from surface waters.”
5. Section 4.5, Page 43 – Add a new section entitled “4.5.1 Coastal Zone Management Act Consistency” under Section 4.5 State, Areawide, and Local Plan and Program Consistency. Move the first sentence that begins “This project does not fall...” to follow the new 4.5.1. Coastal Zone Management Act Consistency section.
6. Section 4.5, Page 43 – Leave the remainder of the paragraph under Section 4.5 as the first paragraph under Section 4.5 State, Areawide, and Local Plan and Program Consistency.
7. Section 4.5, Page 43 – Add the following new sections after Section 4.5.1 Coastal Zone Management Act Consistency.

4.5.2 Oregon State Law

Statewide Planning Goal 11: Public Facilities and Services

The proposed project complies with Goal 11 of Oregon's Statewide Planning Goals. Section A(6) of Goal 11's Planning Guidelines states: "All utility lines and facilities should be located on or adjacent to existing public or private rights-of-way to avoid dividing existing farm units." The proposed project would be constructed entirely in an existing ROW. The footprint of the transmission towers would not change, except in one location where 3 new poles would be installed to facilitate crossing under other existing utilities.

Section B(4) of the Goals' Implementation Guidelines states: "Plans should designate sites of power generation and the location of electric transmission lines in areas intended to support desired levels of urban and rural development." The proposed project is essential to maintaining reliable electrical services in the Salem area.

#### Oregon Administrative Rules

The following provisions of the Oregon Administrative Rules (OAR) are applicable to the proposed project.

OAR 345-024-0090 Siting Standards for Transmission Lines, states that the design, construction, and operation of transmission lines do not exceed 9-kV per meter at one meter above the ground in areas accessible to the public and that induced currents from the transmission line be as low as reasonably possible.

The proposed project would add a line to an existing 230-kV transmission line that runs between Santiam Substation and PGE's Bethel Substation. The existing line and towers would be removed and new towers would be built to accommodate two 230-kV lines. The same standards for the existing transmission line would be met with the new line; therefore, as proposed the project is consistent with OAR 345-024-0090.

OAR 345-022-0000 General Standards for Siting Non-Nuclear Facilities, states that the facility complies with the requirements of the Oregon Energy Facility Siting statutes and that the overall public benefits of the facility outweigh the damage to the resources protected by the standards. As proposed, the project is consistent with OAR 345-022-0000.

#### 4.5.3 Linn County Comprehensive Plans and Development Code

Linn County's Comprehensive Plan contains the following policies that are applicable to the proposed project:

Utility services should be coordinated with other key facilities and services in order to reduce total development costs. This should

include full utilization of easements and rights-of-way in order to reduce total costs and visual impacts.

According to Linn County's Land Development Code, non-dwelling, non-soil dependent uses are permitted in the EFU zoning district through a Type IIA conditional use review, including the utility facilities necessary for public service, except commercial facilities for the purpose of generating power for public use by sale (928.320 (B) (5)).

Given that the proposed project is not a change to a pre-existing use, no land use reviews would be required by Linn County Planning and Building Department, and the proposed project is consistent with the Linn County Land Development Code (Wheeldon, June 6, 2001).

#### 4.5.4 Marion County Comprehensive Plans and Ordinances

The Marion County Comprehensive Plan does not have any policies that directly address utilities; however, it does contain the following energy policies that are applicable to the proposed project:

- Future development should progress in the most energy efficient manner possible.
- It is the intent of the County to encourage conservation of present energy sources and the use and development of alternative sources.
- Plans for the development of new transportation facilities and the improvement of present facilities should be designed to achieve the most energy efficient system possible.
- Public facility planning provides the framework for future urban growth. It is essential that energy consumption and recycling be considered in determining the type, location, and delivery of public facilities and services.
- Industry is a primary consumer of energy, and land use planning should serve to direct the type, design and location of industrial development in the most energy efficient manner possible.

Within Marion County, the proposed project would be located entirely in the Exclusive Farm Use (EFU) zone. Within the EFU zone, the Marion County Zoning Code 136.040, *Uses Permitted Subject to Standards – Other Uses*, applies:

Utility facilities necessary for public service, except commercial facilities for the purpose of generating power for public use by sale

and transmission towers over 200 feet in height. A facility is “necessary” if it must be situated in the EFU zone in order for the service to be provided.

Since the project is an existing use and the transmission towers would not exceed 200 feet, no land use reviews would be required by Marion County and the proposed project is consistent with the Marion County Zoning Code (Fennimore, June 8, 2001).

Department of Energy  
Bonneville Power Administration

SANTIAM-BETHEL TRANSMISSION LINE PROJECT

Finding of No Significant Impact (FONSI)  
and Floodplain Statement of Findings

**Summary:** Bonneville Power Administration (BPA) proposes to rebuild the first 17 miles of the Santiam-Chemawa transmission line from Santiam Substation to the line's connection (tap) to Portland General Electric's (PGE) Bethel Substation to improve transmission system reliability in the Salem area of northwestern Oregon. BPA would replace the existing single-circuit 230-kilovolt (kV) line with towers that could support two circuits (double-circuit) in the existing right-of-way. The existing line supplies both Bethel Substation and BPA's Chemawa Substation. The new lines would eliminate overloading of the existing line from Santiam Substation to the tap to Bethel Substation by having one new line supply Bethel Substation and the other new line supply Chemawa Substation.

BPA has prepared an Environmental Assessment (DOE/EA-1366) evaluating the proposed project. Based on the analysis in the EA, BPA has determined that the Proposed Action is not a major Federal action significantly affecting the quality of the human environment, within the meaning of the National Environmental Policy Act (NEPA) of 1969. Therefore, the preparation of an Environmental Impact Statement (EIS) is not required and BPA is issuing this FONSI. A Floodplain Statement of Findings is also included.

**Copies:** For copies of this FONSI and/or the EA, call BPA's toll-free document request line at 1-800-622-4520, and record your name, address, project name, and the document(s) you wish. The documents are also on the Internet at [www.efw.bpa.gov/cgi-bin/PSA/NEPA/SUMMARIES/SantiamBethel](http://www.efw.bpa.gov/cgi-bin/PSA/NEPA/SUMMARIES/SantiamBethel).

**For Further Information Contact:** Tish Levesque – KEC-4, Bonneville Power Administration, P.O. Box 3621, Portland, Oregon, 97208-3621; phone number 503-230-3469; fax number 503-230-5699; e-mail [tklevesque@bpa.gov](mailto:tklevesque@bpa.gov).

**Supplementary Information:** BPA's existing Santiam-Chemawa No.1 230-kV transmission line is about 25 miles long and is located in Linn and Marion counties in Oregon. BPA is proposing to rebuild the first 17 miles of the Santiam-Chemawa transmission line from Santiam Substation to the tap to PGE's Bethel Substation. BPA's Santiam-Chemawa No.1 transmission line serves BPA customers that in turn serve communities in the Willamette Valley. This line provides voltage support and also backs up BPA's 500-kV transmission system in case one of BPA's 500-kV lines or substations goes out of service.

The existing BPA Santiam-Chemawa 230-kV transmission line is at risk of overloading during peak winter electrical power usage (maximum demand). During normal and extreme winter peak load conditions, outages on BPA's 500-kV or 230-kV transmission grid in the area could

cause the Santiam Substation to Bethel Substation section of the Santiam-Chemawa line to overload. For example, an outage of BPA's Pearl-Marion No.1 500-kV line during extreme cold winter peak load conditions could cause the line to overload. During normal winter peak load conditions, an outage of BPA's Santiam-Albany No.1 230-kV line or an outage of BPA's Albany 230/115-kV transformer would also overload the line.

An overload could damage electrical equipment sensitive to power fluctuations. An overload could cause the line to sag too close to the ground, which could harm people or property under the line. In addition, an overload could cause switches on the Santiam-Chemawa line to automatically take the line out of service, which could create blackouts in the Salem area. Overloading the line could also cause permanent damage to the conductor and BPA would be required to remove the line from service. Removing the line from service could curtail electrical power in the area. BPA needs to improve system reliability by rebuilding the Santiam-Chemawa line to a double-circuit line.

Low, minor, short-term, or temporary impacts from construction of the Proposed Action would occur to the following resources: fish and wildlife, soils, water quality, land use, socioeconomics, visual resources, and vegetation resources. Though noise would disturb wildlife close to the construction area, wildlife would most likely return after the disturbance is removed. Although unlikely, construction may create indirect or temporary increases in soil erosion to streams near the right-of-way, which could affect water quality and fish habitat. Mitigation measures would be used to prevent erosion. Potential impacts would diminish after disturbed areas are restored and erosion and runoff control measures take effect. Construction related noise, dust, traffic disruption, and crop harvest disruption would also temporarily disturb human populations. Spending in the local community and an increase in employment would be short-term but beneficial. Minor visual impacts may occur from construction activities in certain locations along the right-of-way. The new towers would be taller than the existing towers. Noxious weeds could grow in the right-of-way as the ground surface and vegetation are disturbed during construction. Radio and television interference from the new line could occur temporarily, but BPA would promptly correct all interference.

A biological assessment (BA) was prepared to evaluate the potential effect of the project on the bald eagle, northern spotted owl, Fender's blue butterfly, the Upper Willamette River chinook salmon ESU, the Upper Willamette River steelhead ESU, Oregon chub, Nelson's checker-mallow, Bradshaw's lomatium, Willamette daisy, golden Indian paintbrush, water Howellia, and Kincaid's lupine. Based on a review of the latest federal threatened and endangered species lists, review of habitat requirements, and use of project mitigation measures proposed in the BA and the EA, it is BPA's opinion that the proposed project "may affect but is not likely to adversely affect" all the listed species that may be present in the project area except the northern spotted owl. It is BPA's opinion that the proposed project would have "no effect" on the northern spotted owl. The National Marine Fisheries Service (NMFS) and U.S. Fish and Wildlife Service (USFWS) concurred with these findings.

Background research indicated that no prehistoric or historic-period archaeological sites have been recorded within a one-mile radius of any tower locations or right-of-way along the 17-mile portion of line to be rebuilt. As part of the field study 90 discrete areas were surveyed and 33 areas were



investigated using shovel test probes. No archaeological materials were observed on the ground surface at any of the tower locations or within the right-of-way between the towers. One prehistoric artifact was recovered from a total of 34 shovel test probes excavated along the 17-mile portion of right-of-way. Artifact isolates are not recognized as sites by the Oregon State Historic Preservation Officer (SHPO) and the single prehistoric artifact does not represent a cultural resource potentially eligible for listing in the National Register of Historic Places. It is BPA's opinion that the proposed project would have no effect on cultural resources. The Oregon SHPO concurred with these findings. During review of the Preliminary EA, the Confederated Tribes of Grand Ronde discussed with BPA the presence of areas of cultural sensitivity in the project vicinity. To ensure protection of the culturally-sensitive areas, a member of the Tribe would be present during construction activities at those sites.

No impacts are expected to wetland and floodplains, and public health and safety.

BPA also studied the No Action Alternative. For the No Action Alternative, BPA would not rebuild the Santiam-Chemawa transmission line. As a result, normal and extreme cold winter load conditions could cause thermal overloading of existing facilities.

The Proposed Action would not violate Federal, State, or local law or requirements imposed for protection of the environment. All applicable permits would be obtained.

***Floodplain Statement of Findings:*** This is a Floodplain Statement of Findings prepared in accordance with 10 C.F.R. Part 1022. A Notice of Floodplain and Wetlands Involvement was published in the Federal Register on May 11, 2001, and a floodplain and wetlands assessment was incorporated in the EA. BPA is proposing to rebuild its existing Santiam-Chemawa No.1 230-kV line in the existing right-of-way that crosses the 100-year floodplains of the North Santiam River and a tributary to the Pudding River. No impacts to the floodplains would occur because no construction activities would occur within the floodplains, and their floodplain characteristics would not be altered. The Proposed Action conforms to applicable State or local floodplain protection standards.

BPA will allow 15 days of public review after publication of this statement of findings before implementing the Proposed Action.

***Determination:*** Based on the information in the EA, as summarized here, BPA determines that the Proposed Action is not a major Federal action significantly affecting the quality of the human environment within the meaning of NEPA, 42 U.S.C. 4321 *et seq.* Therefore, an EIS will not be prepared and BPA is issuing this FONSI.

Issued in Portland, Oregon, on January 29, 2002.

/s/ Alexandra B. Smith  
Alexandra B. Smith  
Vice President  
Environment, Fish and Wildlife

## Santiam-Bethel Transmission Line Project Mitigation Action Plan

This Mitigation Action Plan identifies mitigation measures that Bonneville Power Administration (BPA) has committed to for the Santiam-Bethel Transmission Line Project. All measures were identified in the Environmental Assessment. They have been developed in coordination with environmental specialists, design and construction engineers, and maintenance personnel.

Because this project will be built by contract, the mitigation measures discussed in the mitigation action plan will be included in the Construction Contract specifications. The contractor is obligated to implement several of the mitigation measures as identified in the construction contract. The contractor has flexibility in the use of specific mitigation measures or best management practices, as long as impacts are mitigated.

Construction of the project could begin in April of 2002 and would continue through November 2002. If you have any questions about the Mitigation Action Plan, please contact Tish Levesque at (503) 230-3469. If you have any general questions about the project, including the construction schedule, please contact Mark Korsness at (360) 619-6326.

<b>General Resource Category</b>	<b>Mitigation (Responsibility)</b>
Land Use	<ul style="list-style-type: none"> <li>• Affected farmers will receive compensation for lost crop production caused by the construction of the project. (BPA Real Property Services)</li> <li>• Equipment operators and the construction crew will be instructed to leave gates as they are found, open or closed, to avoid disturbances to livestock, and to stay within the right-of-way (ROW) to minimize impacts to crops. (Contractor)</li> <li>• Marker balls will be installed on the conductor where it crosses the North Santiam River to make it more visible to pilots. (Contractor)</li> <li>• Landowners will be compensated to disc or till soil to reduce soil compaction from equipment once construction is completed. (BPA Real Property Services)</li> <li>• Construction activities will be coordinated with agricultural activities as best as practicable. (Contractor)</li> </ul>

Soils	<p>Minimizing disturbance and erosion is a concern at all transmission tower erection sites, construction staging areas, and where access roads would be modified or improved. By following best management practices, impacts will be reduced or eliminated at all sites and would be short term. Best management practices include these mitigation measures:</p> <ul style="list-style-type: none"> <li>• Roadway drainage systems will be designed to control and disperse runoff (e.g., using outsloping roads, water bars, and ditches) to prevent erosion or slope stability problems. (BPA Access Road Engineers)</li> <li>• Access roads will be rocked where necessary. (Contractor)</li> <li>• To minimize erosion, disturbed areas will be returned to their original contour and promptly seeded with a seed mixture suited to the site. (Contractor)</li> <li>• Erosion control measures such as silt fencing, straw mulch, straw bale check dams, and reseeded disturbed areas will be used to contain sediment within work areas. Special erosion control fabrics, such as matting, will be applied where soils and slopes have high erosion potential. In areas where towers are adjacent to waterways (miles 3, 5, 7, 8, 9, 10, 11, 12, and 14), special erosion control measures will be applied to minimize erosion potential and sediment input to the streams. (Contractor)</li> <li>• To reduce disturbance to soils and vegetation, vehicle use will be restricted to access roads and to only those areas around and between towers necessary to get the work done, and topsoil will be left in roughened condition in agricultural areas. (Contractor)</li> <li>• When practical, construction activities will be avoided when soil is wet to reduce soil compaction, rutting, and the resultant loss in soil productivity. (Contractor)</li> <li>• Dust abatement best management practices will be used to minimize the potential for erosion. (Contractor)</li> </ul>
Vegetation	<ul style="list-style-type: none"> <li>• To avoid disturbance to areas of native vegetation, BPA will limit construction from potential habitat for these species and limit construction equipment to previously disturbed areas wherever possible. (BPA Environmental Specialists)</li> <li>• To avoid spreading noxious weeds, vehicles will be washed before they enter the project area. Disturbed nonagricultural areas will be reseeded with a plant mix, fertilized, and mulched preferably in October or November. (Contractor)</li> </ul>

Fish and Wildlife	<ul style="list-style-type: none"> <li>• No construction activities will occur within 75 feet of surface waters (stream or wetland) if practicable. (Contractor)</li> <li>• With the exception of the installation of approximately 4 culverts along unnamed tributaries to Valentine and Mill creeks and an unnamed tributary to the Pudding River, no construction activities will occur in water. (Contractor)</li> <li>• Culvert installations on the two unnamed tributaries to Valentine Creek will be completed during the Oregon Department of Fish and Wildlife’s in-water work period from June 1 to September 30, 2002. The culvert installations in an unnamed tributary to Mill Creek and an unnamed tributary to the Pudding River will occur in the same in-water work period or in dry conditions as the streams are seasonal and are usually dry during the proposed construction work period. (Contractor)</li> <li>• All culvert installations will occur on waterways that are not identified stream reaches with threatened and endangered fish species. (BPA Environmental Specialists)</li> </ul>
Wetlands	<ul style="list-style-type: none"> <li>• There will be no filling in wetlands without a permit from the U.S. Army Corps of Engineers. (BPA Environmental Specialists)</li> <li>• Topsoil will be immediately replaced following construction. (Contractor)</li> <li>• Silt fencing will be placed between construction areas and sensitive resources to prevent sedimentation of those resources. (Contractor)</li> <li>• Weed-free hay bales will be used for erosion control. (Contractor)</li> </ul>
Floodplains	<ul style="list-style-type: none"> <li>• All construction and clearing debris will be removed from within the floodplain boundary. (Contractor)</li> </ul>
Water Quality	<p>To avoid accidental release of petrochemical contaminants to surface waters, the following measures will be used:</p> <ul style="list-style-type: none"> <li>• Mechanized equipment will be stored and maintained at least 150 feet from any surface water (stream or wetland). (Contractor)</li> <li>• Refueling of mechanized equipment will occur at least 400 feet from any surface water (stream or wetland). (Contractor)</li> <li>• Mechanized equipment will be inspected daily for leaks and promptly repaired or replaced if leaking. (Contractor)</li> </ul>

	<ul style="list-style-type: none"> <li>• A stormwater pollution prevention plan will be prepared and implemented. (Contractor)</li> </ul>
Cultural Resources	<ul style="list-style-type: none"> <li>• In the unlikely event that cultural resources are uncovered during construction, work in the immediate vicinity of the discovery will be halted, and BPA will consult with the Oregon State Historic Preservation Officer, the Confederated Tribes of Grand Ronde, and a qualified archaeologist. (Contractor and BPA Environmental Specialists)</li> <li>• To ensure protection of any potentially culturally sensitive areas, a member of the Confederated Tribes of Grand Ronde will be present during construction activities at certain areas along the ROW. (BPA Environmental Specialists)</li> </ul>
Public Health and Safety	<ul style="list-style-type: none"> <li>• Design the Proposed Action to meet Oregon Energy Facility Siting Council (EFSC) and BPA electric field standards. (BPA Design Engineers)</li> <li>• Maintain safe clearances between trees and transmission lines to prevent fires and other hazards. (Contractor)</li> <li>• Require the construction contractor to develop an emergency response plan that includes responding to a potential accidental fire during construction. (Contractor)</li> <li>• Design the line to meet Oregon EFSC requirements for noise. (BPA Design Engineers)</li> <li>• Rectify any TV/radio interference caused by the proposed project. (BPA Real Property Services)</li> </ul>



## Department of Energy

Bonneville Power Administration  
P.O. Box 3621  
Portland, Oregon 97208-3621

January 30, 2002

### **To: People Interested in the Santiam-Bethel Transmission Line Project**

In September 2001, Bonneville Power Administration (BPA) prepared a Preliminary Environmental Assessment (EA) for the Santiam-Bethel Transmission Line Project. You were on our mailing list to receive a copy. Since only two comments were received and only minor changes were needed on the Preliminary EA, it will serve as the Final EA and a separate document will not be issued. An errata sheet listing seven changes, a Finding of No Significant Impact, and a Mitigation Action Plan have been prepared and are enclosed.

**Additional Copies:** If you would like a copy of the EA, or additional copies of the enclosed errata sheet, Finding of No Significant Impact, and/or Mitigation Action Plan, please call our toll-free document request line: 1-800-622-4520. Leave a message naming this project and the documents you wish and giving your complete mailing address. They are also available at our website: [www.efw.bpa.gov](http://www.efw.bpa.gov).

**Proposal:** BPA proposes to rebuild the first 17 miles of the Santiam-Chemawa transmission line from Santiam Substation to the line's connection to Portland General Electric's Bethel Substation to improve transmission system reliability in the Salem area of northwestern Oregon. BPA would replace the existing single-circuit 230-kilovolt line with towers that could support two circuits (double-circuit) in the existing right-of-way. The existing line supplies both Bethel Substation and BPA's Chemawa Substation. The new lines would eliminate overloading of the existing line from Santiam Substation to the tap to Bethel Substation by having one new line supply Bethel Substation and the other new line supply Chemawa Substation.

**For More Information:** If you need more information or have any questions, please call me at my direct number, 503-230-3469, or toll-free at 1-800-282-3713; or e-mail me at [tklevesque@bpa.gov](mailto:tklevesque@bpa.gov). Thank you for your interest in our work.

*/s/ Tish Levesque*

Tish Levesque  
Environmental Project Manager

3 Enclosures:

1. Errata Sheet
2. Finding of No Significant Impact
3. Mitigation Action Plan

**ERRATA SHEET FOR  
SANTIAM-BETHEL TRANSMISSION LINE PROJECT  
FINAL ENVIRONMENTAL ASSESSMENT  
DOE/EA-1366**

January 28, 2002

This errata sheet documents the changes to be incorporated into the Preliminary EA named above. With these changes, the Preliminary EA will serve as the Final EA.

1. Add the following sections to the Table of Contents – “4.5.1 Coastal Zone Management Act Consistency,” “4.5.2 Oregon State Law,” “4.5.3 Linn County Comprehensive Plans and Development Code,” and “4.5.4 Marion County Comprehensive Plans and Ordinances.”
2. Section 3.7.6, page 26 – Add the following sentence after the first sentence of the second paragraph. “No construction activities would occur within 75 feet of surface waters if practicable.”
3. Section 3.7.6, page 26 – Under the paragraph that begins “To avoid the delivery...,” change the third sentence of the second bullet to read: “In areas where towers are adjacent to waterways (miles 3, 5, 7, 8, 9, 10, 11, 12, and 14), special erosion...”
4. Section 3.10.5, page 31 – Add the following bullet after the first bullet: “Refueling of vehicles would occur at least 400 feet from surface waters.”
5. Section 4.5, Page 43 – Add a new section entitled “4.5.1 Coastal Zone Management Act Consistency” under Section 4.5 State, Areawide, and Local Plan and Program Consistency. Move the first sentence that begins “This project does not fall...” to follow the new 4.5.1. Coastal Zone Management Act Consistency section.
6. Section 4.5, Page 43 – Leave the remainder of the paragraph under Section 4.5 as the first paragraph under Section 4.5 State, Areawide, and Local Plan and Program Consistency.
7. Section 4.5, Page 43 – Add the following new sections after Section 4.5.1 Coastal Zone Management Act Consistency.

4.5.2 Oregon State Law

Statewide Planning Goal 11: Public Facilities and Services

The proposed project complies with Goal 11 of Oregon's Statewide Planning Goals. Section A(6) of Goal 11's Planning Guidelines states: "All utility lines and facilities should be located on or adjacent to existing public or private rights-of-way to avoid dividing existing farm units." The proposed project would be constructed entirely in an existing ROW. The footprint of the transmission towers would not change, except in one location where 3 new poles would be installed to facilitate crossing under other existing utilities.

Section B(4) of the Goals' Implementation Guidelines states: "Plans should designate sites of power generation and the location of electric transmission lines in areas intended to support desired levels of urban and rural development." The proposed project is essential to maintaining reliable electrical services in the Salem area.

#### Oregon Administrative Rules

The following provisions of the Oregon Administrative Rules (OAR) are applicable to the proposed project.

OAR 345-024-0090 Siting Standards for Transmission Lines, states that the design, construction, and operation of transmission lines do not exceed 9-kV per meter at one meter above the ground in areas accessible to the public and that induced currents from the transmission line be as low as reasonably possible.

The proposed project would add a line to an existing 230-kV transmission line that runs between Santiam Substation and PGE's Bethel Substation. The existing line and towers would be removed and new towers would be built to accommodate two 230-kV lines. The same standards for the existing transmission line would be met with the new line; therefore, as proposed the project is consistent with OAR 345-024-0090.

OAR 345-022-0000 General Standards for Siting Non-Nuclear Facilities, states that the facility complies with the requirements of the Oregon Energy Facility Siting statutes and that the overall public benefits of the facility outweigh the damage to the resources protected by the standards. As proposed, the project is consistent with OAR 345-022-0000.

#### 4.5.3 Linn County Comprehensive Plans and Development Code

Linn County's Comprehensive Plan contains the following policies that are applicable to the proposed project:

Utility services should be coordinated with other key facilities and services in order to reduce total development costs. This should



include full utilization of easements and rights-of-way in order to reduce total costs and visual impacts.

According to Linn County's Land Development Code, non-dwelling, non-soil dependent uses are permitted in the EFU zoning district through a Type IIA conditional use review, including the utility facilities necessary for public service, except commercial facilities for the purpose of generating power for public use by sale (928.320 (B) (5)).

Given that the proposed project is not a change to a pre-existing use, no land use reviews would be required by Linn County Planning and Building Department, and the proposed project is consistent with the Linn County Land Development Code (Wheeldon, June 6, 2001).

#### 4.5.4 Marion County Comprehensive Plans and Ordinances

The Marion County Comprehensive Plan does not have any policies that directly address utilities; however, it does contain the following energy policies that are applicable to the proposed project:

- Future development should progress in the most energy efficient manner possible.
- It is the intent of the County to encourage conservation of present energy sources and the use and development of alternative sources.
- Plans for the development of new transportation facilities and the improvement of present facilities should be designed to achieve the most energy efficient system possible.
- Public facility planning provides the framework for future urban growth. It is essential that energy consumption and recycling be considered in determining the type, location, and delivery of public facilities and services.
- Industry is a primary consumer of energy, and land use planning should serve to direct the type, design and location of industrial development in the most energy efficient manner possible.

Within Marion County, the proposed project would be located entirely in the Exclusive Farm Use (EFU) zone. Within the EFU zone, the Marion County Zoning Code 136.040, *Uses Permitted Subject to Standards – Other Uses*, applies:

Utility facilities necessary for public service, except commercial facilities for the purpose of generating power for public use by sale

and transmission towers over 200 feet in height. A facility is “necessary” if it must be situated in the EFU zone in order for the service to be provided.

Since the project is an existing use and the transmission towers would not exceed 200 feet, no land use reviews would be required by Marion County and the proposed project is consistent with the Marion County Zoning Code (Fennimore, June 8, 2001).

Department of Energy  
Bonneville Power Administration

SANTIAM-BETHEL TRANSMISSION LINE PROJECT

Finding of No Significant Impact (FONSI)  
and Floodplain Statement of Findings

**Summary:** Bonneville Power Administration (BPA) proposes to rebuild the first 17 miles of the Santiam-Chemawa transmission line from Santiam Substation to the line's connection (tap) to Portland General Electric's (PGE) Bethel Substation to improve transmission system reliability in the Salem area of northwestern Oregon. BPA would replace the existing single-circuit 230-kilovolt (kV) line with towers that could support two circuits (double-circuit) in the existing right-of-way. The existing line supplies both Bethel Substation and BPA's Chemawa Substation. The new lines would eliminate overloading of the existing line from Santiam Substation to the tap to Bethel Substation by having one new line supply Bethel Substation and the other new line supply Chemawa Substation.

BPA has prepared an Environmental Assessment (DOE/EA-1366) evaluating the proposed project. Based on the analysis in the EA, BPA has determined that the Proposed Action is not a major Federal action significantly affecting the quality of the human environment, within the meaning of the National Environmental Policy Act (NEPA) of 1969. Therefore, the preparation of an Environmental Impact Statement (EIS) is not required and BPA is issuing this FONSI. A Floodplain Statement of Findings is also included.

**Copies:** For copies of this FONSI and/or the EA, call BPA's toll-free document request line at 1-800-622-4520, and record your name, address, project name, and the document(s) you wish. The documents are also on the Internet at [www.efw.bpa.gov/cgi-bin/PSA/NEPA/SUMMARIES/SantiamBethel](http://www.efw.bpa.gov/cgi-bin/PSA/NEPA/SUMMARIES/SantiamBethel).

**For Further Information Contact:** Tish Levesque – KEC-4, Bonneville Power Administration, P.O. Box 3621, Portland, Oregon, 97208-3621; phone number 503-230-3469; fax number 503-230-5699; e-mail [tklevesque@bpa.gov](mailto:tklevesque@bpa.gov).

**Supplementary Information:** BPA's existing Santiam-Chemawa No.1 230-kV transmission line is about 25 miles long and is located in Linn and Marion counties in Oregon. BPA is proposing to rebuild the first 17 miles of the Santiam-Chemawa transmission line from Santiam Substation to the tap to PGE's Bethel Substation. BPA's Santiam-Chemawa No.1 transmission line serves BPA customers that in turn serve communities in the Willamette Valley. This line provides voltage support and also backs up BPA's 500-kV transmission system in case one of BPA's 500-kV lines or substations goes out of service.

The existing BPA Santiam-Chemawa 230-kV transmission line is at risk of overloading during peak winter electrical power usage (maximum demand). During normal and extreme winter peak load conditions, outages on BPA's 500-kV or 230-kV transmission grid in the area could

cause the Santiam Substation to Bethel Substation section of the Santiam-Chemawa line to overload. For example, an outage of BPA's Pearl-Marion No.1 500-kV line during extreme cold winter peak load conditions could cause the line to overload. During normal winter peak load conditions, an outage of BPA's Santiam-Albany No.1 230-kV line or an outage of BPA's Albany 230/115-kV transformer would also overload the line.

An overload could damage electrical equipment sensitive to power fluctuations. An overload could cause the line to sag too close to the ground, which could harm people or property under the line. In addition, an overload could cause switches on the Santiam-Chemawa line to automatically take the line out of service, which could create blackouts in the Salem area. Overloading the line could also cause permanent damage to the conductor and BPA would be required to remove the line from service. Removing the line from service could curtail electrical power in the area. BPA needs to improve system reliability by rebuilding the Santiam-Chemawa line to a double-circuit line.

Low, minor, short-term, or temporary impacts from construction of the Proposed Action would occur to the following resources: fish and wildlife, soils, water quality, land use, socioeconomics, visual resources, and vegetation resources. Though noise would disturb wildlife close to the construction area, wildlife would most likely return after the disturbance is removed. Although unlikely, construction may create indirect or temporary increases in soil erosion to streams near the right-of-way, which could affect water quality and fish habitat. Mitigation measures would be used to prevent erosion. Potential impacts would diminish after disturbed areas are restored and erosion and runoff control measures take effect. Construction related noise, dust, traffic disruption, and crop harvest disruption would also temporarily disturb human populations. Spending in the local community and an increase in employment would be short-term but beneficial. Minor visual impacts may occur from construction activities in certain locations along the right-of-way. The new towers would be taller than the existing towers. Noxious weeds could grow in the right-of-way as the ground surface and vegetation are disturbed during construction. Radio and television interference from the new line could occur temporarily, but BPA would promptly correct all interference.

A biological assessment (BA) was prepared to evaluate the potential effect of the project on the bald eagle, northern spotted owl, Fender's blue butterfly, the Upper Willamette River chinook salmon ESU, the Upper Willamette River steelhead ESU, Oregon chub, Nelson's checker-mallow, Bradshaw's lomatium, Willamette daisy, golden Indian paintbrush, water Howellia, and Kincaid's lupine. Based on a review of the latest federal threatened and endangered species lists, review of habitat requirements, and use of project mitigation measures proposed in the BA and the EA, it is BPA's opinion that the proposed project "may affect but is not likely to adversely affect" all the listed species that may be present in the project area except the northern spotted owl. It is BPA's opinion that the proposed project would have "no effect" on the northern spotted owl. The National Marine Fisheries Service (NMFS) and U.S. Fish and Wildlife Service (USFWS) concurred with these findings.

Background research indicated that no prehistoric or historic-period archaeological sites have been recorded within a one-mile radius of any tower locations or right-of-way along the 17-mile portion of line to be rebuilt. As part of the field study 90 discrete areas were surveyed and 33 areas were

investigated using shovel test probes. No archaeological materials were observed on the ground surface at any of the tower locations or within the right-of-way between the towers. One prehistoric artifact was recovered from a total of 34 shovel test probes excavated along the 17-mile portion of right-of-way. Artifact isolates are not recognized as sites by the Oregon State Historic Preservation Officer (SHPO) and the single prehistoric artifact does not represent a cultural resource potentially eligible for listing in the National Register of Historic Places. It is BPA's opinion that the proposed project would have no effect on cultural resources. The Oregon SHPO concurred with these findings. During review of the Preliminary EA, the Confederated Tribes of Grand Ronde discussed with BPA the presence of areas of cultural sensitivity in the project vicinity. To ensure protection of the culturally-sensitive areas, a member of the Tribe would be present during construction activities at those sites.

No impacts are expected to wetland and floodplains, and public health and safety.

BPA also studied the No Action Alternative. For the No Action Alternative, BPA would not rebuild the Santiam-Chemawa transmission line. As a result, normal and extreme cold winter load conditions could cause thermal overloading of existing facilities.

The Proposed Action would not violate Federal, State, or local law or requirements imposed for protection of the environment. All applicable permits would be obtained.

***Floodplain Statement of Findings:*** This is a Floodplain Statement of Findings prepared in accordance with 10 C.F.R. Part 1022. A Notice of Floodplain and Wetlands Involvement was published in the Federal Register on May 11, 2001, and a floodplain and wetlands assessment was incorporated in the EA. BPA is proposing to rebuild its existing Santiam-Chemawa No.1 230-kV line in the existing right-of-way that crosses the 100-year floodplains of the North Santiam River and a tributary to the Pudding River. No impacts to the floodplains would occur because no construction activities would occur within the floodplains, and their floodplain characteristics would not be altered. The Proposed Action conforms to applicable State or local floodplain protection standards.

BPA will allow 15 days of public review after publication of this statement of findings before implementing the Proposed Action.

***Determination:*** Based on the information in the EA, as summarized here, BPA determines that the Proposed Action is not a major Federal action significantly affecting the quality of the human environment within the meaning of NEPA, 42 U.S.C. 4321 *et seq.* Therefore, an EIS will not be prepared and BPA is issuing this FONSI.

Issued in Portland, Oregon, on January 29, 2002.

/s/ Alexandra B. Smith  
Alexandra B. Smith  
Vice President  
Environment, Fish and Wildlife

## Santiam-Bethel Transmission Line Project Mitigation Action Plan

This Mitigation Action Plan identifies mitigation measures that Bonneville Power Administration (BPA) has committed to for the Santiam-Bethel Transmission Line Project. All measures were identified in the Environmental Assessment. They have been developed in coordination with environmental specialists, design and construction engineers, and maintenance personnel.

Because this project will be built by contract, the mitigation measures discussed in the mitigation action plan will be included in the Construction Contract specifications. The contractor is obligated to implement several of the mitigation measures as identified in the construction contract. The contractor has flexibility in the use of specific mitigation measures or best management practices, as long as impacts are mitigated.

Construction of the project could begin in April of 2002 and would continue through November 2002. If you have any questions about the Mitigation Action Plan, please contact Tish Levesque at (503) 230-3469. If you have any general questions about the project, including the construction schedule, please contact Mark Korsness at (360) 619-6326.

<b>General Resource Category</b>	<b>Mitigation (Responsibility)</b>
Land Use	<ul style="list-style-type: none"> <li>• Affected farmers will receive compensation for lost crop production caused by the construction of the project. (BPA Real Property Services)</li> <li>• Equipment operators and the construction crew will be instructed to leave gates as they are found, open or closed, to avoid disturbances to livestock, and to stay within the right-of-way (ROW) to minimize impacts to crops. (Contractor)</li> <li>• Marker balls will be installed on the conductor where it crosses the North Santiam River to make it more visible to pilots. (Contractor)</li> <li>• Landowners will be compensated to disc or till soil to reduce soil compaction from equipment once construction is completed. (BPA Real Property Services)</li> <li>• Construction activities will be coordinated with agricultural activities as best as practicable. (Contractor)</li> </ul>

<p>Soils</p>	<p>Minimizing disturbance and erosion is a concern at all transmission tower erection sites, construction staging areas, and where access roads would be modified or improved. By following best management practices, impacts will be reduced or eliminated at all sites and would be short term. Best management practices include these mitigation measures:</p> <ul style="list-style-type: none"> <li>• Roadway drainage systems will be designed to control and disperse runoff (e.g., using outsloping roads, water bars, and ditches) to prevent erosion or slope stability problems. (BPA Access Road Engineers)</li> <li>• Access roads will be rocked where necessary. (Contractor)</li> <li>• To minimize erosion, disturbed areas will be returned to their original contour and promptly seeded with a seed mixture suited to the site. (Contractor)</li> <li>• Erosion control measures such as silt fencing, straw mulch, straw bale check dams, and reseeded disturbed areas will be used to contain sediment within work areas. Special erosion control fabrics, such as matting, will be applied where soils and slopes have high erosion potential. In areas where towers are adjacent to waterways (miles 3, 5, 7, 8, 9, 10, 11, 12, and 14), special erosion control measures will be applied to minimize erosion potential and sediment input to the streams. (Contractor)</li> <li>• To reduce disturbance to soils and vegetation, vehicle use will be restricted to access roads and to only those areas around and between towers necessary to get the work done, and topsoil will be left in roughened condition in agricultural areas. (Contractor)</li> <li>• When practical, construction activities will be avoided when soil is wet to reduce soil compaction, rutting, and the resultant loss in soil productivity. (Contractor)</li> <li>• Dust abatement best management practices will be used to minimize the potential for erosion. (Contractor)</li> </ul>
<p>Vegetation</p>	<ul style="list-style-type: none"> <li>• To avoid disturbance to areas of native vegetation, BPA will limit construction from potential habitat for these species and limit construction equipment to previously disturbed areas wherever possible. (BPA Environmental Specialists)</li> <li>• To avoid spreading noxious weeds, vehicles will be washed before they enter the project area. Disturbed nonagricultural areas will be reseeded with a plant mix, fertilized, and mulched preferably in October or November. (Contractor)</li> </ul>

Fish and Wildlife	<ul style="list-style-type: none"> <li>• No construction activities will occur within 75 feet of surface waters (stream or wetland) if practicable. (Contractor)</li> <li>• With the exception of the installation of approximately 4 culverts along unnamed tributaries to Valentine and Mill creeks and an unnamed tributary to the Pudding River, no construction activities will occur in water. (Contractor)</li> <li>• Culvert installations on the two unnamed tributaries to Valentine Creek will be completed during the Oregon Department of Fish and Wildlife’s in-water work period from June 1 to September 30, 2002. The culvert installations in an unnamed tributary to Mill Creek and an unnamed tributary to the Pudding River will occur in the same in-water work period or in dry conditions as the streams are seasonal and are usually dry during the proposed construction work period. (Contractor)</li> <li>• All culvert installations will occur on waterways that are not identified stream reaches with threatened and endangered fish species. (BPA Environmental Specialists)</li> </ul>
Wetlands	<ul style="list-style-type: none"> <li>• There will be no filling in wetlands without a permit from the U.S. Army Corps of Engineers. (BPA Environmental Specialists)</li> <li>• Topsoil will be immediately replaced following construction. (Contractor)</li> <li>• Silt fencing will be placed between construction areas and sensitive resources to prevent sedimentation of those resources. (Contractor)</li> <li>• Weed-free hay bales will be used for erosion control. (Contractor)</li> </ul>
Floodplains	<ul style="list-style-type: none"> <li>• All construction and clearing debris will be removed from within the floodplain boundary. (Contractor)</li> </ul>
Water Quality	<p>To avoid accidental release of petrochemical contaminants to surface waters, the following measures will be used:</p> <ul style="list-style-type: none"> <li>• Mechanized equipment will be stored and maintained at least 150 feet from any surface water (stream or wetland). (Contractor)</li> <li>• Refueling of mechanized equipment will occur at least 400 feet from any surface water (stream or wetland). (Contractor)</li> <li>• Mechanized equipment will be inspected daily for leaks and promptly repaired or replaced if leaking. (Contractor)</li> </ul>



	<ul style="list-style-type: none"> <li>• A stormwater pollution prevention plan will be prepared and implemented. (Contractor)</li> </ul>
Cultural Resources	<ul style="list-style-type: none"> <li>• In the unlikely event that cultural resources are uncovered during construction, work in the immediate vicinity of the discovery will be halted, and BPA will consult with the Oregon State Historic Preservation Officer, the Confederated Tribes of Grand Ronde, and a qualified archaeologist. (Contractor and BPA Environmental Specialists)</li> <li>• To ensure protection of any potentially culturally sensitive areas, a member of the Confederated Tribes of Grand Ronde will be present during construction activities at certain areas along the ROW. (BPA Environmental Specialists)</li> </ul>
Public Health and Safety	<ul style="list-style-type: none"> <li>• Design the Proposed Action to meet Oregon Energy Facility Siting Council (EFSC) and BPA electric field standards. (BPA Design Engineers)</li> <li>• Maintain safe clearances between trees and transmission lines to prevent fires and other hazards. (Contractor)</li> <li>• Require the construction contractor to develop an emergency response plan that includes responding to a potential accidental fire during construction. (Contractor)</li> <li>• Design the line to meet Oregon EFSC requirements for noise. (BPA Design Engineers)</li> <li>• Rectify any TV/radio interference caused by the proposed project. (BPA Real Property Services)</li> </ul>

## 1.0 Need for and Purpose of Action

### 1.1 Introduction

The Bonneville Power Administration's (BPA) existing Santiam-Chemawa No. 1 230-**kilovolt\*** (kV) transmission line is about 25 miles long and is located in Linn and Marion counties in Oregon. BPA's Santiam-Chemawa No.1 transmission line serves BPA customers that in turn serve communities in the Willamette Valley. This line provides **voltage** support and also backs up BPA's 500-kV transmission system in case one of BPA's 500-kV lines or substations goes out of service.

BPA is proposing to rebuild the first 17 miles of the Santiam-Chemawa transmission line from Santiam Substation to the line's connection (**tap**) to Portland General Electric's (PGE) Bethel Substation. (See Map 1.) The Santiam-Chemawa transmission line parallels BPA's Marion-Santiam 500-kV Nos. 1 and 2 transmission lines from Santiam Substation to BPA's Marion Substation. BPA would replace the existing **single-circuit** Santiam-Chemawa 230-kV line with towers that could support two circuits (**double circuit**). The existing line supplies both Bethel Substation and BPA's Chemawa Substation. The new lines would eliminate overloading of the existing line from Santiam Substation to the tap to Bethel Substation by having one new line supply Bethel Substation and the other new line supply Chemawa Substation.

BPA originally proposed a new transmission line next to an existing 230-kV line. As a result of the comments received during the scoping period, the proposal was changed. BPA is now proposing a double-circuit line instead of a single-circuit line. (See Section 2.3.)

### 1.2 Underlying Need for Action

BPA's underlying need for action is to improve transmission system reliability in the Salem area of northwestern Oregon. The existing BPA Santiam-Chemawa 230-kV transmission line is at risk of **overloading** during peak winter electrical power usage (maximum demand). During normal and extreme winter peak **load** conditions, outages on BPA's 500-kV or 230-kV transmission grid in the area could cause the Santiam Substation to Bethel Substation section of the Santiam-Chemawa line to overload. For example, an outage of BPA's Pearl-Marion No.1 500-kV line during extreme cold winter peak load conditions could cause the line to overload. During normal winter peak load conditions, an outage of BPA's Santiam-Albany No.1 230-kV line or an outage of BPA's Albany 230/115-kV transformer would also overload the line. (See Map 1.)

---

\*Words in bold are defined in the glossary. See Section 7.

An overload could damage electrical equipment sensitive to power fluctuations. An overload could cause the line to sag too close to the ground, which could harm people or property under the line. In addition, an overload could cause switches on the Santiam-Chemawa line to automatically take the line out of service, which could create blackouts in the Salem area. Overloading the line could also cause permanent damage to the **conductor** (the wires that carry current in a transmission line) and BPA would be required to remove the line from service. Removing the line from service could curtail electrical power in the area.

### 1.3 Purposes

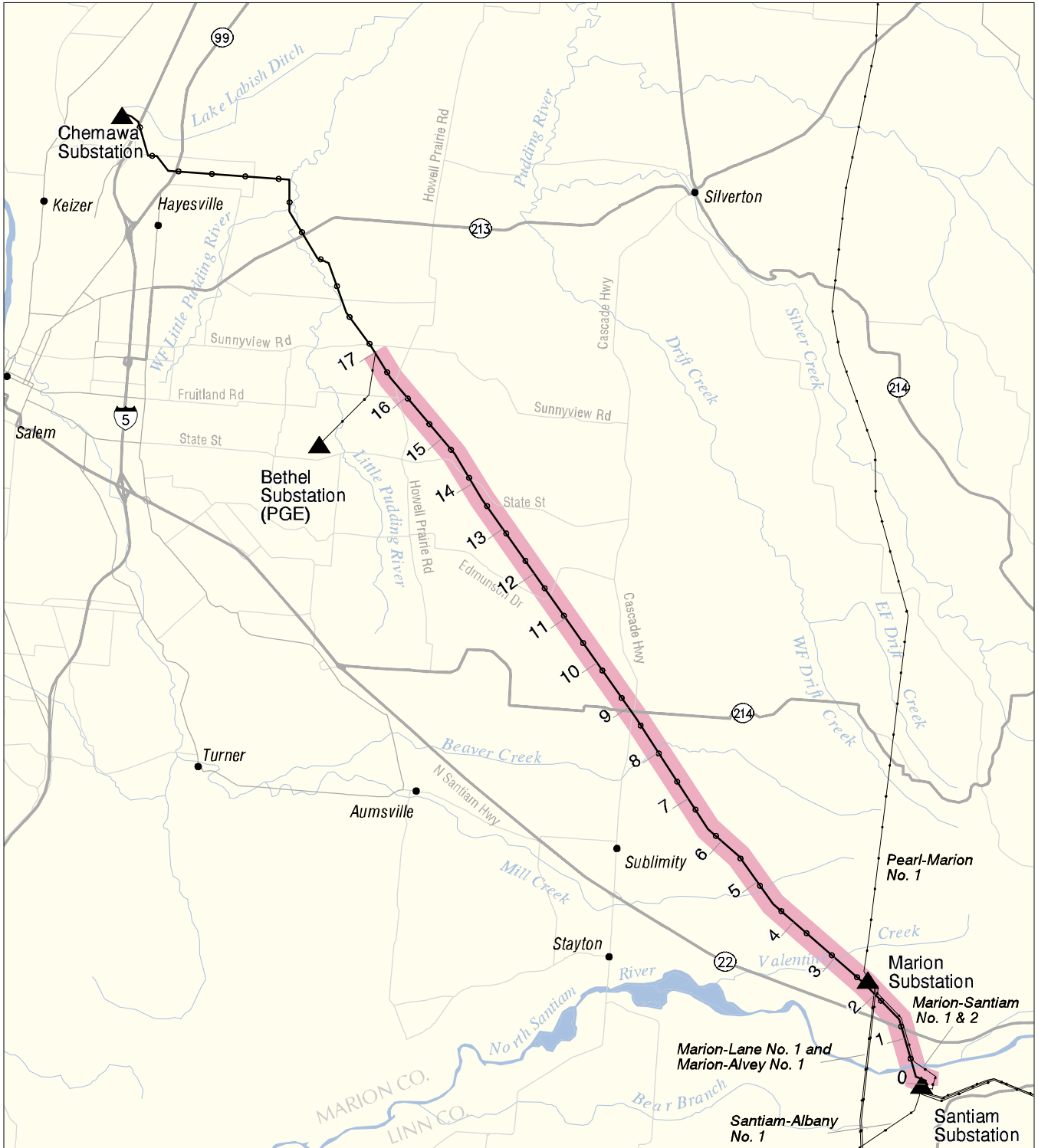
The purposes in the “purpose and need” statement are goals to be achieved while meeting the need for the project. In satisfying the underlying need, BPA wants to achieve the following purposes:

- Minimize environmental impacts
- Minimize costs
- Improve transmission system reliability.

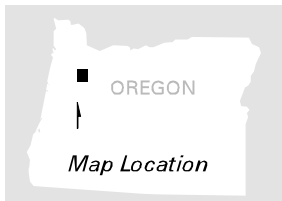
### 1.4 Public Involvement

On November 20, 2000, BPA sent a letter to people potentially interested in or affected by the proposed Santiam-Bethel Transmission Line Project. This letter explained the proposal, the environmental process, and how to participate in the process. BPA originally proposed a new transmission line next to an existing 230-kV line. BPA received comments on the proposal by phone, e-mail, and letter. In addition, BPA received comments at a public meeting held in Sublimity, Oregon, on December 11, 2000. Most comments focused on the initial proposal and its likely environmental impacts. As a result of the comments received, the proposal was changed. BPA is now proposing a double-circuit line instead of a single-circuit line. (See Sections 2.1 and 2.3.)

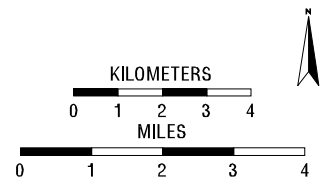
# SANTIAM - BETHEL TRANSMISSION LINE PROJECT



September 24, 2001



- 4 - Mileage Marker
- ▲ Substation
- Road/Highway
- Santiam-Chemawa No. 1 Transmission Line
- Existing Transmission Line
- Proposed Double-Circuit Line



**Map 1**

## 2.0 Proposed Action and Alternatives

### 2.1 Proposed Action

BPA is proposing to rebuild a 17-mile portion of its existing Santiam-Chemawa No.1 transmission line from single-circuit 230-kV to double-circuit 230-kV with the following exceptions stated below. The new double-circuit line would occupy the existing Santiam-Chemawa No.1 **right-of-way (ROW)** and would be constructed from BPA's Santiam Substation to the tap to PGE's Bethel Substation. At the tap, the new double-circuit line would split to single-circuit, with one circuit connecting into PGE's existing line to Bethel Substation and the other circuit connecting to BPA's existing line to Chemawa Substation. (See Map 1.)

The line would be double circuit except in the following three areas where it would be single circuit:

- The new Santiam-Bethel line and existing Santiam-Chemawa line would come out of Santiam Substation as two single-circuit lines. The second tower in mile 1 of the existing Santiam-Chemawa line would be rebuilt and would be the first double-circuit tower to carry both the existing and the new lines.
- In mile 2 of the proposed project, three new single-circuit towers would be built to allow passage of the new lines under BPA's existing Marion-Lane and Marion-Alvey 500-kV lines.
- In mile 17 at the tap to PGE's Bethel Substation, two BPA towers would be removed and replaced with one double-circuit tower in about the same location. PGE's two existing 3-pole wood structures at this location would be removed and replaced with one new 3-pole wood structure on PGE's ROW just southwest of BPA's new double-circuit tower. This would allow the new line to tie back into the existing single-circuit line.

All existing steel lattice towers would be replaced with taller steel lattice towers in approximately the same locations. The taller lattice towers would be about 135 feet (ft) high, about 65 ft taller than those supporting the existing single-circuit 230-kV line. (See Figure 1.) Approximately 1,400 feet of new access road would need to be constructed along the existing ROW. About 14 **danger** trees would need to be cleared. Danger trees are trees outside the ROW that could fall and damage the line. Three additional ROW easements would need to be purchased near Santiam Substation and in miles 2 and 17. Some additional trees in the new ROW near Santiam Substation or elsewhere may need to be cut.

The total cost of the project would be about \$12 million.

### 2.2 No Action Alternative

In the No Action Alternative, BPA would not rebuild the Santiam-Chemawa transmission line. As a result, normal and extreme cold winter load conditions could cause thermal overloading of existing facilities. (See Section 1.2.)

## 2.3 Alternatives Eliminated from Consideration

During the scoping process, a number of commentors suggested alternatives. In addition, BPA systems planners also developed alternatives. The following alternatives were eliminated for the reasons given.

### *2.3.1 Construct a New Single-Circuit Line*

BPA originally proposed to construct a new single-circuit 230-kV transmission line next to the existing single-circuit Santiam-Chemawa No.1 line. This alternative would eliminate the overloading but would require a 125-foot wide ROW. The new line would directly impact landowners by taking prime agricultural lands out of service. Because of the potential environmental impacts, this alternative was eliminated from consideration.

### *2.3.2 Reconductor the Single-Circuit Line*

Another alternative that was considered was rebuilding the existing single-circuit 230-kV line with a larger conductor 230-kV line. This would require a complete rebuild of the existing circuit. Although this alternative would relieve the overload in the short term, the new single-circuit line could overload again in 4-5 years, requiring BPA to develop a new solution for the problem at that time. Because it would not solve the long-term need for the project, this alternative was eliminated from further consideration.

### *2.3.3 Conservation*

BPA has extensive experience with energy conservation in the Pacific Northwest. Conservation programs are typically used to solve problems and modify electricity use patterns in limited geographic areas at specific times of the day and year. Although conservation measures would reduce energy consumption in the area, they would not be enough to solve the problem of overloading during peak winter electricity usage.

### *2.3.4 Building an Underground Transmission Line*

Some people suggested that BPA consider putting the new line underground. BPA considers and at times has used underground transmission cables for new lines. Transmission line cables are highly complex in comparison to overhead transmission lines. Even with current technologies, transmission cables normally exceed the cost of overhead transmission lines by many times.

Because of the cost, BPA uses underground cable in limited special reliability or routing situations. Examples of these situations are locations where unusually high circuit reliability is required, such as near nuclear power stations and locations where high capacity lines must cross. Underground cables are also considered where an overhead route is not appropriate, such as at long bay crossings or in urban areas. Underground cables are also considered for lower voltage lines when this would provide a route for a new higher capacity line and minimize the cost of the new line.

# Santiam - Bethel Transmission Line Project

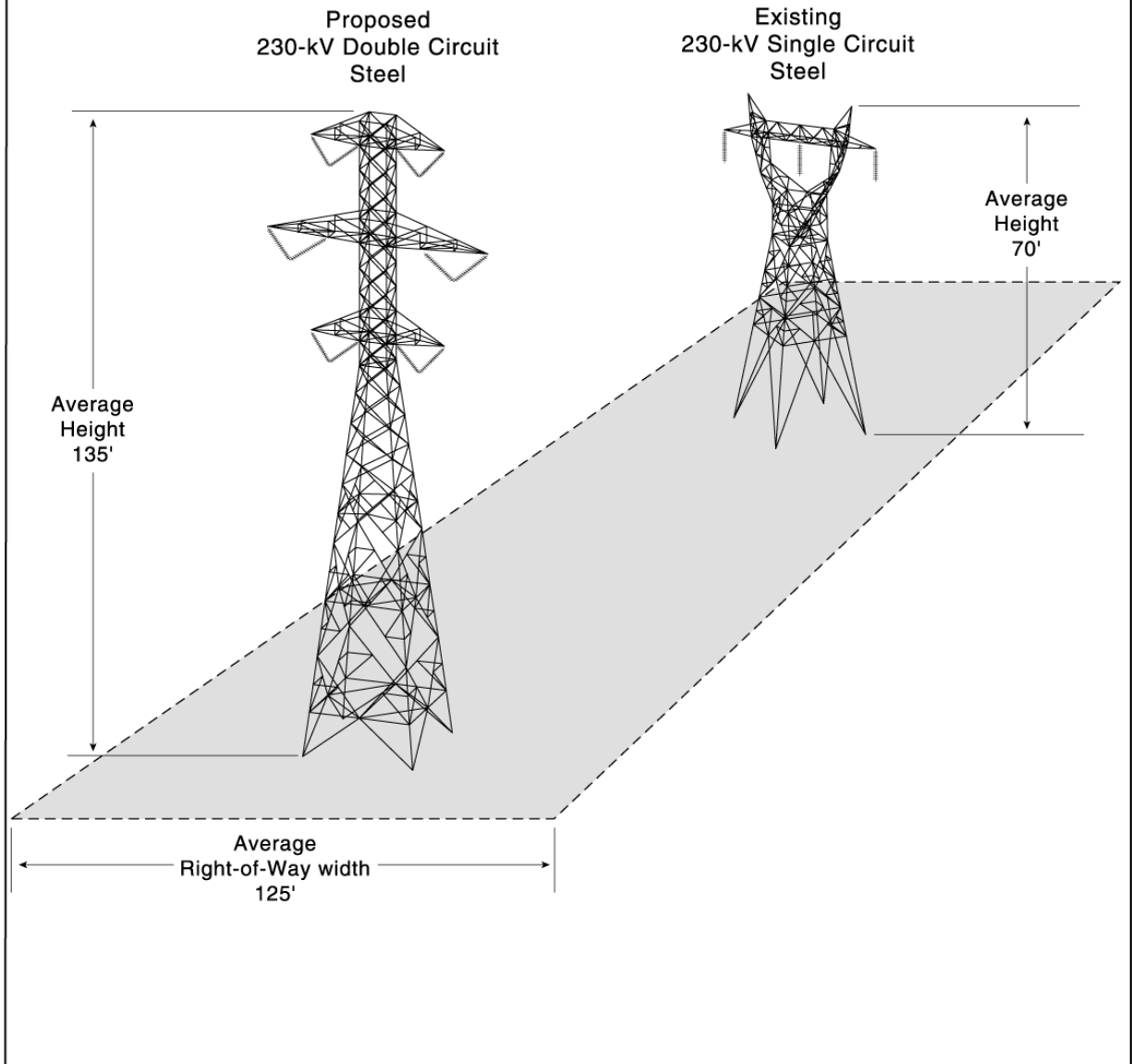


Figure 1  
Existing and Proposed Structures

Since underground transmission cables are only used in a few specific situations, transmission cables used by BPA are short in comparison to typical overhead transmission lines. BPA's longest underground transmission cable (at 115-kV) is 8 miles.

BPA has kept abreast of transmission cable technologies. Cable technologies have not advanced as fast as the industry anticipated they would 10 years ago, nor have costs declined as expected. Cable remains a tool available for special situations, but because of its high cost it was eliminated from further consideration.

## 2.4 Comparison of Alternatives

The Proposed Action would have minor and/or short-term environmental impacts. The Proposed Action would be more expensive in the short-term but less expensive in the long-term due to improved system reliability. Rebuilding the Santiam-Chemawa transmission line would improve system reliability by preventing potential thermal overloading, voltage collapse, and loss of load on the existing system.

The No Action Alternative minimizes environmental impacts; however, it could have similar impacts to the Proposed Action if thermal overloading causes the existing system to fail and the line needed to be replaced in the future. The No Action Alternative costs nothing now but would be more expensive in the long term if system reliability is compromised. The No Action Alternative could result in power outages and potential damage to the line and property near the line.

Table 1 summarizes potential environmental impacts of the Proposed Action and the No Action Alternative.



Table 1 Summary of Impacts

<b>Environmental Resource</b>	<b>Proposed Action</b>	<b>No Action Alternative</b>
<b>Land Use</b>	Localized and temporary disruption of maintenance or harvest of active agricultural fields. Short-term, construction related impacts such as noise, dust, soil compaction and erosion.	Impacts associated with maintenance of the existing line would continue.
<b>Socioeconomics</b>	Minor and temporary increases in the use of local motels/hotels, recreational parks, and campgrounds by construction workers. Minor increase in employment and spending in the local economy over the short-term.	Outages could result; increased maintenance costs.
<b>Visual Resources</b>	Short-term and minor impacts from construction activities in certain locations along the ROW. Change in visual appearance from existing line. However, the rebuild would be within an existing transmission line corridor, so the visual change would be minor.	No impacts expected.
<b>Soils and Geology</b>	Short-term increases in erosion accompanying access road improvements, pole assembly and erecting, and clearing to provide access to work areas. Heavy equipment could also compact sites, reducing soil productivity. Long-term impacts could include localized runoff and erosion at structure sites or where access roads have been built or modified.	No impacts expected.
<b>Vegetation</b>	Potential increase in weedy, non-native vegetation in the ROW, primarily Scot's broom and Himalayan blackberry, from vehicular traffic and ground surface and vegetation disturbance during construction.	No impacts expected.
<b>Fish and Wildlife</b>	Temporary displacement of species sensitive to human activity from habitats adjacent to the project area. Removal of danger trees within or next to the ROW may result in a minor reduction of wildlife habitat available. Removal of danger trees along the North Santiam River and an unnamed tributary to Beaver Creek could have a minor effect on riparian function. Temporary and localized noise disturbance. Degraded water quality from possible chemical spills and sediment from erosion during construction.	No impacts expected.
<b>Wetlands</b>	No impacts expected.	No impacts expected.
<b>Floodplain</b>	No impacts expected.	No impacts expected.
<b>Water Quality</b>	Degraded water quality from possible chemical spills and sediment from erosion during construction.	No impacts expected.
<b>Cultural Resources</b>	No impacts expected.	No impacts expected.
<b>Public Health and Safety</b>	No impacts expected.	No impacts expected.
<b>Noise and Radio/Television Interference</b>	Possible (and correctable) minor interference with radio/television reception.  Short-term increases in noise during construction.	No impacts expected.



## 3.0 Affected Environment and Environmental Impacts

### 3.1 Land Use

#### 3.1.1 *Affected Environment*

Land uses in the vicinity of the proposed project include agricultural, rural residential, and a few commercial facilities along the existing ROW. About 75 percent of the land in the transmission line ROW is agricultural cropland and 10 percent is pastureland. The remaining 15 percent is residential land and natural habitat.

Agricultural uses along the transmission line ROW include crop production (field and grass seed, Christmas trees) cattle and sheep grazing, and turkey farming. On the ROW, about 193 acres are agricultural land and 26 acres are pastureland.

#### 3.1.2 *Potential Impacts of the Proposed Action*

Most of the work for the proposed rebuild project would occur within BPA's existing 125-foot ROW and substation property. Additional ROW easements would only need to be purchased along three small segments of the existing ROW, and the footprint of the existing transmission line towers would generally be used for the installation of most of the new 135-foot towers. Access roads would be upgraded as required for construction. In addition, approximately 1,400 feet of new access road would need to be constructed along the existing ROW and approximately 9,700 lineal feet of access road easements on existing roads off the existing transmission line ROW would need to be acquired.

BPA has transmission line easements along the entire ROW that were acquired from private landowners. No public lands are being crossed. Fourteen danger trees would be removed.

##### 3.1.2.1 Agricultural Lands

Potential short-term impacts to agriculture from the construction of the proposed project could include temporary and localized disruption of maintenance and/or harvest of agricultural products in actively cultivated fields where towers are replaced. Other impacts could include potential temporary and localized increases in dust, noise, soil compaction, and erosion. Although there would be some loss of crop yield in active agricultural fields due to equipment ingress and egress and staging and construction of towers, the construction would not change existing agricultural uses in the project area.

An evaluation of soil survey information for the existing transmission line ROW indicated that the majority of the ROW is located in prime farmland soils. The proposed project would be constructed mostly in an existing ROW, and mostly within existing structure footprints and would have little to no impact on area farmlands.

Mostly existing roads and rights-of-way would be used to access the transmission line towers, to dismantle the existing towers, and to construct the new towers. The only impacts

associated with the installation of the new transmission line would occur primarily at the tower pads. Once each tower site is accessed, it is estimated that a 125- by 200-foot (25,000-square-foot) to a 200- by 200-foot (40,000-square-foot) area would be used for staging and construction, and for placement of the tower foundations. Based on review of aerial photographs of the transmission line ROW, there would be approximately 85 towers replaced in agricultural fields. Assuming that these 85 towers are in actively cultivated fields and construction would result in a disturbance area of 25,000 to 40,000 square feet, an estimated 49 to 78 acres of active agricultural land could be temporarily affected by construction. This represents approximately 0.02 to 0.03 percent of all field and grass seed acreage within Marion and Linn counties, and 0.01 to less than 0.02 percent of all croplands within the counties. Replacement of the transmission line towers would have a minor to negligible effect on overall cropland production in the counties, but might have a noticeable effect on individual farmers whose lands would be affected.

Individual farmers would be compensated by BPA for any loss of crops and for post-construction activities necessary to return disturbed areas of agricultural fields to production. BPA would also employ dust abatement **best management practices** to minimize the potential for erosion (see Section 3.5.5).

Because the proposed project involves rebuilding an existing transmission line using the existing footprint and access roads in the ROW, operation and maintenance impacts would be minor and consistent with current practices. However, the increased height of transmission line towers from 70 to 135 feet could affect crop dusting in the area if this increase in height interferes with flight pathways.

#### 3.1.2.2 Residential and Commercial Lands

There are approximately 70 to 80 buildings in the vicinity of the ROW, 17 of which are within 100 feet of the ROW. Most buildings are associated with farmsteads. Other buildings in the vicinity of the ROW include farm outbuildings and commercial facilities. These buildings would not be affected and the land use would not change.

#### 3.1.2.3 Property Impacts

Affected landowners would be offered market value, established through the appraisal process, for the transmission line and/or access road perpetual easements. The appraisal process takes all factors affecting value into consideration including the impact of transmission lines on property value. The appraisals may reference studies conducted on similar properties to add support to valuation considerations. The strength of any appraisal is dependent on the individual analysis of the property, using neighborhood specific market data to determine market value.

Impacts to property for new rights-of-way for transmission lines and access roads are discussed below.

**New transmission line right-of-way** - The predominant land use for the new transmission line right-of-way consists of agricultural cropland and pastureland, with a small portion being comprised of residential and natural habitat.

BPA's transmission line easement documents encumbers the right-of-way area with land use limitations. The easement specifies, "the present and future right to clear the right-of-way and to keep the same clear of all trees, whether natural or cultivated, and all structure supported crops, other structures, trees, brush, vegetation, fire and electrical hazards, except non-structure supported agricultural crops less than 10 feet in height." The landowner may grow most crops or graze livestock. Special written agreements may be entered into between BPA and the landowner to allow Christmas, ornamental or orchard trees, and structure-supported crops. Heights of the trees/crops and access must be controlled to maintain safe distances.

The impact of introducing a new right-of-way for transmission towers and lines can vary dramatically depending on the placement of the right-of-way in relation to the property's size, shape, and location of existing improvements. A transmission line may diminish the utility of a portion of property if the line effectively severs this area from the remaining property (severance damage). Whether a transmission line introduces a negative visual impact is dependent on the placement of the line across a property as well as each individual landowners' perception of what is visually acceptable or unacceptable.

If the transmission line crosses a portion of the property in agricultural use such as pasture or cropland, little utility is lost between the towers, but 100 percent of the utility is lost within the base of the tower. Towers may also present an obstacle for operating farm equipment, and controlling weeds at tower locations. To the extent possible, new transmission lines are designed to minimize the impact to existing and proposed (if known) irrigation systems. If the introduction of a transmission line creates a need to redesign irrigation equipment or layout, BPA compensates the landowner for this additional cost.

These factors as well as any other elements unique to the property are taken into consideration to determine the loss in value within the easement area, as well as outside the easement area in cases of severance.

Market value would be paid for any timber to be cut on the new right-of-way, as well as for any trees off the right-of-way that need to be cut for construction purposes or that pose a danger of falling into the line or across the access roads.

**New access roads** - If BPA acquires an easement on an existing access road and the landowner is the only other user, market compensation is generally 50 percent of full fee value or something less than 50 percent if other landowners share the access road use. For fully improved roads, the appraiser may prepare a cost analysis to identify the value of the access road easement. If BPA acquires an easement for the right to construct a new access road and the landowner has equal benefit and need of the access road, market compensation is generally 50 percent of full fee value. If the landowner has little or no use for the new access road to be constructed, market compensation for the easement is generally close to full fee value.

**Property Value Impacts** - The proposed transmission line is not expected to have long-term impacts on property values in the area. Whenever land uses change, the concern is often raised as to the effect the change may have on property values nearby. Zoning is the primary means that most local governments use to protect property values. By allowing some uses and disallowing others, or permitting them only as conditional uses, conflicting uses are avoided. Some residents consider transmission lines to be an incompatible use adjacent to residential areas; however, this feeling is not universal.

The question of whether nearby transmission lines can affect residential property values has been studied numerous times in the United States and Canada over the last twenty years or so, with mixed results. In 1995, BPA contributed to the research when it looked at the sale of 296 pairs of residential properties in the Portland, Oregon metropolitan area (including Vancouver, Washington) and in King County, Washington. The study evaluated properties adjoining 16 BPA high voltage transmission lines (subjects) and compared them with similar property sales located away from transmission lines (comps). All of the sales were in 1990 and 1991 and adjustments were made for time and other factors. The results of the study showed that the subjects in King County were worth approximately 1 percent less than their matched comps, while the Portland/Vancouver area subjects were worth almost 1.5 percent more (Cowger et al. 1996).

BPA recently updated this earlier study using 1994/95 sales data. The sales of 260 pairs of residential properties in King County and Portland/Vancouver metropolitan areas were reviewed. The information confirmed the results of the earlier study, i.e., that the presence of high voltage transmission lines does not significantly affect the sale price of residential properties. The residential sales did, however, identify a small but negative impact from 0 to 2 percent for those properties adjacent to the transmission lines as opposed to those where no transmission lines were present. Although this study identified a negative effect, the results are similar to the earlier study and the differences are relatively small (Cowger et al., 2000).

Studies of impacts during periods of physical change, such as new transmission line construction or structural rebuilds, generally have revealed greater short-term impacts than long-term effects. However, most studies have concluded that other factors, such as general location, size of property, improvements, condition, amenities and supply and demand factors in a specific market area are far more important criteria than the presence or absence of transmission lines in determining the value of residential real estate.

As a result of the proposed project, some short-term adverse impacts on property values (and salability) might occur on an individual basis; however, these impacts would be highly variable, individualized, and unpredictable. Constructing the transmission line is not expected to cause long-term adverse effects to property values along the right-of-way or in the general vicinity. Non-project impacts, along with other general market factors, are already reflected in the market value of properties in the area. These conditions are not expected to change appreciably. Therefore, no long-term impacts to property values are expected as a result of the proposed project.

### *3.1.3 Potential Impacts of the No Action Alternative*

The existing transmission line had a minor effect on agricultural production when the towers were installed in the early 1950s. There would be no further impacts to agriculture from the No Action Alternative other than those caused by maintenance of the existing line.

### *3.1.4 Cumulative Impacts*

The existing transmission line had a minor effect on agricultural production when the towers were installed in the early 1950s. The proposed project would convert only a small amount of land to another use. Soil disturbance and increased vehicular traffic associated with construction

activities could increase the potential for the spread of **noxious weeds**. No future expansions or additions to the existing corridor are being considered at this time. Consultations with Linn County and Marion County planning departments have indicated that there are no recent or foreseeable developments or projects in the vicinity of the ROW that would contribute to cumulative impacts associated with the proposed project (Hopkins, May 1, 2001; Fennimore, April 21, and June 8, 2001). Cumulative impacts to land uses would be minor.

### *3.1.5 Mitigation for the Proposed Action*

To mitigate the potential impacts identified above, the following mitigation measures would be implemented:

- Affected farmers would receive compensation for lost crop production caused by the construction of the project.
- Equipment operators and the construction crew would be instructed to close gates to avoid disturbances to livestock, and to stay within the ROW to minimize impacts to crops.
- To minimize the establishment of noxious weeds, construction crews would wash equipment and vehicles before entering construction areas.
- Marker balls would be installed on the conductor as it crosses the North Santiam River to make it more visible to pilots.
- BPA would compensate landowners to disc or till soil to reduce soil compaction from equipment once construction is completed.
- Conduct construction activities in coordination with agricultural activities.

## 3.2 Socioeconomics

### *3.2.1 Affected Environment*

#### 3.2.1.1 Population and Demographics

The population of Marion County grew from 228,438 in 1990, to 284,834 in 2000. The population of Linn County grew from 91,227 in 1990, to 103,069 in 2000. The average annual growth rate over this period was consistent with the overall growth rate for the state of Oregon during this same time period (1.5 percent). (U.S. Bureau of the Census, 1990; Portland State University Population Research Center, 2000.)

Caucasians predominate among ethnic groups in Marion and Linn counties. In Marion County, Asian and Pacific Islanders and Native Americans were the second and third most predominant ethnic groups in 2000, respectively. In Linn County, Native Americans and Asian and Pacific Islanders were the second and third most predominant ethnic group in 2000, respectively. (Portland State University Population Research Center, 2000.)

### 3.2.1.2 Employment, Economy, and Income

Marion County's largest employment sectors (and greatest annual earnings sectors) were services, government, and retail trade, respectively. These 3 sectors represented 23 percent, 20 percent, and 18 percent of the county's total workforce, respectively. (U.S. Bureau of Economic Analysis, 1998.) The largest employment sectors (and greatest annual earnings sectors) for Linn County in 1998 were manufacturing, services, and retail trade. These sectors represented 24 percent, 22 percent, and 17 percent of the county's total workforce, respectively. (U.S. Bureau of Economic Analysis, 1998.) The 1998 employment sector and annual earnings distributions for Marion and Linn counties were relatively similar to the state.

The unemployment rate for the state in 1999 was 5.7 percent, compared to 6.3 percent for Marion County and 8.0 percent for Linn County (Oregon Labor Market Information System, 2001).

The estimated median household income for Marion and Linn counties in 1997 was \$36,853 and \$36,107 respectively, which was only slightly lower than the median income for the state of Oregon in 1997 (\$37,284). (U.S. Bureau of the Census 1997).

In comparison, the percentage of the population below the poverty level in 1997 for the state was 11.6 percent. In 1997, Marion County and Linn County had 13.2 percent and 12.3 percent of their populations below the poverty level. (U.S. Bureau of the Census, 1997.)

### 3.2.2 Potential Impacts of the Proposed Action

Transmission line construction requires skilled labor and equipment that are unique; therefore the prime contractor for the project would likely come from outside the local area (e.g., from the Seattle or Portland areas). Construction workers would earn wages averaging about \$38 per hour, depending on the trade and level of responsibility.

Construction of the transmission line is expected to begin in May 2002 or 2003 with the line being energized in November of the same year, a construction period of approximately 6 months. The work force required for construction would vary over the 6-month period ranging from approximately 18 workers in the initial and final stages of construction to approximately 33 workers during the peak of construction activities.

Depending on where the transmission line workers reside and whether construction would involve a 5-day or 6-day work week, the construction crews would typically stay in the area until the project is completed. Construction workers would either stay in temporary housing (motels/hotels) or bring their own accommodations (recreational vehicles) and stay in recreational vehicle (RV) parks or campgrounds. These facilities are available in the area. Because of the limited number of workers (approximately 18 to 33) and the short duration of the construction project (approximately 6 months), impacts on the commercial lodging industry in the area would be minor. Overall, the short-term construction impacts would be considered beneficial to the local economy. The proposed project would create a minor increase in employment and spending in the local economy over the short term.

The proposed project would not create any long-term impacts on the region's population because the project would not induce growth. There would be no long-term impacts on housing.



Operation and maintenance of the line would continue to be under the purview of BPA. Normal maintenance would involve brush clearing by a BPA contractor, ordinarily performed every 5 years. This employment impact would be low because it would not contribute to a significant increase of employment in either county.

### *3.2.3 Potential Impacts of the No Action Alternative*

The No Action Alternative assumes that no transmission facilities would be replaced. Not replacing these facilities could result in more outages for BPA customers and potentially increased maintenance costs (in both time and materials) to keep the existing line in operation.

### *3.2.4 Cumulative Impacts*

The existing transmission line had a minor effect on the local economy when it was built in the early 1950s. No future expansions or additions to the existing corridor are expected at this time. Cumulative impacts on the population or economy of the region would be minor.

### *3.2.5 Mitigation for the Proposed Action*

No mitigation measures are required to address socioeconomic impacts of the project because there would be no in migration or impacts on housing, and there would be a somewhat positive impact on the local economy through project employment and expenditures.

## 3.3 Visual Resources

Construction activities with potential visual impacts include removal of the existing 70-foot steel towers, installation of the 135-foot towers, the stringing of conductor wires, and the upgrading of access roads. The potential long-term visual impacts would result from a change in the visual appearance of the transmission line after the replacement of the 70-foot towers with 135-foot steel towers.

The methodology used to assess the visual resources and visual impacts of the proposed project generally conforms to the Visual Management System developed by the U.S. Forest Service, and the Visual Resource Inventory developed by the Bureau of Land Management. Topography, vegetation (size and shape), and developed land uses were reviewed using U.S. Geological Survey (USGS) quadrangle maps, aerial photos, photographs, and project maps. Field reconnaissance and a helicopter survey were conducted to determine the general visibility of the existing transmission line from sensitive viewpoints (e.g., residences, travel routes, parks, and public areas).

Potential visual impacts resulting from the proposed project were evaluated by assessing the visual quality of the project area, viewer sensitivity, the degree of visual changes from the existing environment, and the visibility of changes from the sensitive viewpoints.

Visual quality in the project area was assessed using the following descriptions:

- **Urban/developed landscapes.** These are common to urban areas and urban fringes. Human elements in such landscapes are prevalent and certain landscape modifications may exist that do not blend with the natural surroundings.
- **Rural landscapes.** These landscapes exhibit reasonably attractive natural and human-made features/patterns, although they are not visually distinctive or unusual within the region. The landscape provides positive visual experiences such as the presence of natural or open space interspersed with existing agricultural areas (farm fields, etc.).
- **Scenic/distinctive landscapes.** These exhibit distinctive and memorable visual features (e.g., landforms, rock outcrops, streams/rivers, scenic vistas) and patterns (vegetation, open space) that usually occur in an undisturbed rural setting but may also be found in an urban setting.

Viewer sensitivity in this evaluation is described as a combination of viewer type, viewer exposure (number of viewers and view frequency), view orientation, view duration, and viewer awareness/sensitivity to visual changes.

Indoor workers (i.e., at the meat packing plant) in the project area were considered to have low visual sensitivity, since most of their activities are typically indoors. Highway and local travelers crossing or coming close to the transmission ROW and agricultural and other workers in the vicinity were considered to have moderate visual sensitivity. Although travelers and local workers in the project vicinity would frequently view the proposed project facilities, they would be focused on driving or work activities with short-term visual exposure. Residential and recreational viewers were considered to have moderate to high visual sensitivity, depending on their proximity to and visibility of the project area. These viewers would have a longer period of visual exposure.

### *3.3.1 Affected Environment*

The proposed project would take place within an approximately 125-foot-wide transmission ROW that has existed since 1953.

Beginning at the Santiam Substation (mile 1) and continuing to the Marion Substation (mile 3), the existing transmission ROW contains two transmission lines supported on steel lattice towers (including Santiam-Chemawa), and several smaller power lines on wood poles intersect the transmission lines. The existing transmission line exits the Marion Substation and is intersected by telephone and electrical transmission lines in 15 locations. A PGE 230-kV transmission line crosses the existing transmission line in mile 9 and mile 17. The existing BPA ROW crosses through rolling hills and flat lands used for agriculture, interspersed with small, forested patches and occasional drainage courses. The background along the route varies between tree-covered hills and the Cascade Mountain foothills. Rural development (mainly farmsteads) and some commercial development (e.g., manufacturing facilities, commercial farms) occur intermittently along the ROW. Because the transmission line has existed since the early 1950s, it has been a part of the viewscape in the project area for nearly 3 generations.

### *3.3.2 Potential Impacts of the Proposed Action*

The greatest visual exposure to the proposed transmission line upgrade within the existing electrical transmission ROW would be from the approximately 70 to 80 residences and farmsteads located intermittently along the ROW; the Fitzmaurice Fertilizer Company in the vicinity of mile 9; and the Bruce Pac Meat Plant and Doerfler Farms in the vicinity of miles 9 and 10.

The visual impact from the proposed project to these potential viewers is considered low to moderate, based on the following:

- The proposed rebuild would occur within an established electrical transmission line ROW that is close to these potential viewers. These viewers already have decreased sensitivity to the visual components associated with the proposed project including operation and maintenance activities.
- The construction activities associated with the rebuild would be of limited duration and would be widely spaced.
- Although different in appearance (taller towers) from the existing transmission line, the rebuild would be visually similar. Views of the rebuilt line would blend in with or be partially screened by trees, landscaping, hilly terrain, and other buildings along the route.

There are 14 areas along the existing ROW where travelers could be visually exposed to the transmission line either from roads crossing under or coming close to the ROW. The potential visual impact to these travelers is considered low for the same reasons as stated above. In addition, the duration of exposure would be limited as travelers passed under or close to the transmission line and their attention would be focused on driving.

For the remainder of the existing ROW, there would be minimal potential visual impacts because there is limited exposure to potential viewers, and the transmission line crosses areas that are visually less sensitive.

### *3.3.3 Potential Impacts of the No Action Alternative*

No visual impacts are expected to occur beyond those already occurring from the existing transmission line.

### *3.3.4 Cumulative Impacts*

The existing transmission line had an effect on visual resources when the towers were installed in the early 1950s. The addition of taller towers would create a range of visual effects from low to moderate, depending on the sensitivity of the viewer. No future expansion or additions to the existing ROW are anticipated at this time.

## 3.4 Recreation

### *3.4.1 Affected Environment*

There are no formal recreational facilities immediately next to the existing transmission line ROW in Marion or Linn counties.

### *3.4.2 Potential Impacts of the Proposed Action*

No or minor impacts on recreation are expected during construction of the proposed project. No formal recreational facilities exist in the immediate vicinity of the project site. Deer and upland bird hunting in the surrounding area and fishing on the North Santiam River and some of the smaller creeks may be interrupted temporarily in the vicinity of the project during construction.

No long-term operation and maintenance impacts on recreation are anticipated because the project would not directly affect the facilities. However, the 130-foot transmission towers would be more visible than the existing 70-foot transmission towers and might have a slightly greater negative aesthetic effect on the users' recreational experience in the area.

### *3.4.3 Potential Impacts of the No Action Alternative*

No impacts to recreation are expected beyond those already occurring from the existing line.

### *3.4.4 Cumulative Impacts*

The existing transmission line had a minor effect on recreation when the towers were installed in the early 1950s. The proposed project would introduce taller towers into a rural setting sometimes used for recreation.

## 3.5 Soils and Geology

### *3.5.1 Affected Environment*

The ROW is located on the west side of the Cascade Range within the Willamette Valley physiographic province. Elevations in the project vicinity range from 200 feet near the tap to about 900 feet maximum in mile 4. Within much of the project area, soils have formed on gently sloping low foothills and nearly level stream terraces and are well- to moderately well-drained. Soils on the foothills have formed in materials derived from basalt and compacted volcanic fragments. Stream terrace soils have developed in silty alluvium of mixed origins, which were deposited by past stream actions.

### *3.5.2 Potential Impacts of the Proposed Action*

Soils denuded of vegetation or disturbed by construction activities are more susceptible to erosion. An increase in erosion can reduce soil productivity and degrade water quality. The amount of soil erosion caused by construction is a function of soil properties, slope, vegetation, rainfall patterns, and construction practices. The potential for erosion is slight throughout the project area except in areas where the slope is approximately 7 percent or greater, and in the 100-year floodplain of the North Santiam River. The potential hazard of soil erosion is moderate in these areas.

Impacts would be primarily related to disturbances associated with tower construction, conductor-stringing operations, clearing to provide access to work areas, and road improvements. Impacts would include localized increases in erosion and runoff rates at construction sites. Heavy equipment could also compact sites, reducing soil productivity. Impacts would be greatest during and immediately after construction until the disturbed sites have been revegetated. Revegetation and rehabilitation of compacted sites would reduce runoff and erosion rates to near pre-construction levels. Changes in localized runoff and erosion patterns at structure sites or where access roads have been built or modified are possible long-term impacts. Because the proposed project involves rebuilding an existing transmission line using the existing footprint and access roads in the ROW, operation and maintenance impacts would be minor and consistent with current practices.

### *3.5.3 Potential Impacts of the No Action Alternative*

Because no grading or road maintenance would occur, there would be no impacts to earth resources other than those already occurring from the existing line.

### *3.5.4 Cumulative Impacts*

Past, current, and future land development activities, including forest and agricultural management practices, could increase erosion and introduce sediment into surface waters. The Proposed Action would be constructed to prevent interference with any ongoing conservation efforts to control erosion and maintain water quality. Although minor, localized increases in erosion, runoff, and sedimentation are expected from construction and maintenance, these increases would have a low short-term impact on the area's soil resources and water quality. The Proposed Action would not further impair the current or future beneficial use of land or water resources.

### *3.5.5 Mitigation for the Proposed Action*

Minimizing disturbance and erosion is a concern at all transmission tower erection sites, construction staging areas, and where access roads would be modified or improved. By following best management practices, impacts would be reduced or eliminated at all sites and would be short term. Best management practices include these mitigation measures:

- Design roads to control run-off and prevent erosion.

- To minimize erosion, disturbed areas would be returned to their original contour and promptly seeded with a seed mixture suited to the site.
- Sediment barriers and other suitable erosion control devices would be installed where needed to minimize movement of sediment.
- When practical, construction activities would be avoided when soil is wet to reduce soil compaction, rutting, and the resultant loss in soil productivity.
- Farm operators would be assisted in restoring productivity of compacted soils.
- Water trucks would be used on an as-needed basis to minimize dust.

## 3.6 Vegetation

### *3.6.1 Affected Environment*

The proposed project is located within an existing electrical transmission ROW in habitats that are predominantly nonforested. Over 75 percent of the vegetation cover within the ROW is agricultural field. An additional 10 percent is pastureland. Approximately 3 percent of the ROW is wetland. Vegetation cover in the remaining 12 percent of the ROW includes mixed Douglas fir and Oregon oak woodlots, abandoned agricultural fields, and rural residential lands.

The prevalent habitat within the ROW is agricultural. The project is located within a portion of the Willamette Valley where grass seed production predominates. Other cover types within the ROW include low shrubs, such as Scot's broom, emergent wetlands, scrub-shrub wetlands dominated by willows and Pacific ninebark, and heavily disturbed, frequently-mowed weedy vegetation.

There are 29 waterway crossings (i.e., drainage ditch, stream) in the project area. These waterways crossing the ROW provide aquatic habitat. Some of the wetland and terrestrial habitats have value to wildlife; all are common in Marion County and neighboring Willamette Valley areas.

### *3.6.2 Potential Impacts of the Proposed Action*

Ground surface and vegetation disturbance during construction of the new transmission line could increase the presence of weedy, non-native vegetation in the ROW, primarily Scot's broom and Himalayan blackberry. However, with the use of the mitigation measures described in Section 3.1.5, the potential impacts from these non-native species are considered low. Because the proposed project involves rebuilding an existing transmission line using the existing footprint and access roads in the ROW, operation and maintenance impacts would be minor and consistent with current practices.

### 3.6.3 Potential Impacts of the No Action Alternative

The No Action Alternative would continue vegetation maintenance and clearing to maintain the ROW. BPA standard management practices, which are defined in the Transmission System Vegetation Management Programmatic Environmental Impact Statement (DOE/EIS-0285, June 2000), would be applied to avoid or minimize potential impacts to vegetation.

The Vegetation Management Programmatic Environmental Impact Statement is available at: [http://www.efw.bpa.gov/cgi-bin/PSA/NEPA/SUMMARIES/VegetationManagement\\_EIS0285](http://www.efw.bpa.gov/cgi-bin/PSA/NEPA/SUMMARIES/VegetationManagement_EIS0285).

### 3.6.4 Threatened and Endangered Species

The U.S. Fish and Wildlife Service (USFWS) has identified two federally-listed endangered and four federally-listed threatened plant species with potential to occur in the project area (McMaster, October 27, 2000) (see Table 2). There are documented occurrences of the 2 federally-listed species in a portion of the project area. These are Willamette daisy (*Erigeron decumbens* var. *decumbens*) and Bradshaw's lomatium (*Lomatium bradshawii*).

The Oregon Natural Heritage Program recorded a Willamette daisy population and a Bradshaw's lomatium population near mile 7 within the project area in 1997. A **palustrine emergent wetland** is found in this area. The periphery of the wetland, in the transition area to upland, provides potential habitat for the Willamette daisy. Those portions of the wetland that are moist to saturated, but not inundated, provide potential habitat for the Bradshaw's lomatium. A survey of the documented occurrence area near mile 7 determined that there is potential habitat present.

### 3.6.5 Cumulative Impacts

The existing transmission line had an effect on vegetation when the towers were installed in the early 1950s. There are no other ongoing or planned activities along the ROW being considered at this time. Should additions or expansions in the ROW or adjacent areas be planned, the activities could create additional impacts to vegetation.

### 3.6.6 Mitigation for the Proposed Action

The principal potential impacts to native vegetation include disturbance or modification of potential habitat, accidental spread of non-native plant species, and accidental spills of petrochemicals. BPA would include the following mitigation measures to avoid and minimize potential impacts of the project to native vegetation including federally-listed plant species.

- To avoid disturbance to areas of native vegetation, BPA would limit construction from potential habitat for these species and limit construction equipment to previously disturbed areas.

- To avoid spreading noxious weeds, vehicles would be washed before they enter the project area. Disturbed nonagricultural areas would be reseeded with a plant mix, fertilized, and mulched.

**Table 2 – Federally-Listed Species**

<b>Species</b>	<b>Status</b>	<b>Occurrence in ROW</b>
Willamette daisy <i>(Erigeron decumbens)</i>	TE	Documented
Bradshaw’s lomatium <i>(Lomatium bradshawii)</i>	LE	Documented
Nelson’s checker-mallow <i>(Sidalcea nelsoniana)</i>	LT	No Documented Populations
Kincaid’s lupine <i>(Lupinus sulphureus)</i>	LT	No Documented Populations
golden paintbrush <i>(Castilleja levisecta)</i>	LT	No Documented Populations
water Howellia <i>(Howellia aquatillis)</i>	LT	No Documented Populations
Notes: LT = Federally-Listed Threatened; LE = Federally-Listed Endangered Sources: U.S. Fish and Wildlife Service Oregon State Office, October 27,2000.		

### 3.7 Fish and Wildlife

#### 3.7.1 Affected Environment

The proposed project is located within the Western Interior Valleys Province of Oregon, as described in the Oregon Wildlife Diversity Plan (ODFW, 1993). Wildlife habitats in this province have been altered by human development and conversion of native habitats to agriculture. Habitats that exist within and next to the ROW include riparian areas containing second growth coniferous forest, coniferous forest mixed with hardwoods, and grass and herbaceous vegetation; and upland areas containing second growth coniferous forest, second growth coniferous forest mixed with Garry oak, and areas of grasses and herbaceous vegetation. However, most of the area (75 percent) within and adjacent to the ROW contains agricultural fields.

Wildlife species common to the area that have adapted to human development include opossum, scrub jay, house finch, brown-headed cowbird, and Anna’s hummingbird. Other species that may occur in the project area include acorn woodpecker, grasshopper sparrow,



Lewis's woodpecker, red-tailed hawk, northern harrier, American kestrel, western bluebird, black tailed jack rabbit, mule deer, and several species of bats including little brown myotis, Yuma myotis, California bat, silver haired bat, big brown bat, and hoary bat (ODFW, 1993; Maser, 1998).

Of these, the Lewis's woodpecker is considered sensitive in Oregon. Both the acorn woodpecker and Lewis's woodpecker are strongly associated with oak habitat, and the Lewis's woodpecker is also associated with riparian habitat. Oak habitat occurs in the project area outside of the ROW both within and outside of riparian zones.

The project is within the Molalla-Pudding River and North Santiam River basins, which drain into the Willamette River, a tributary of the Columbia River. The Molalla-Pudding River Basin consists primarily of forest riparian and agricultural/urban riparian land types and has a watershed area of approximately 887 square miles. The North Santiam River Basin consists primarily of forest riparian and agricultural/urban riparian land types and has a watershed of approximately 767 square miles. There are 29 waterway crossings (i.e., drainage ditch or stream crossings) in the project area. Major drainages crossed by the ROW include the North Santiam River, Alder Creek, Valentine Creek, Mill Creek, and Beaver Creek. Streams vary in width from approximately 150 feet (North Santiam River) to 1 to 2 feet. Most streams are low gradient (1 to 2 percent) with **substrate** consisting primarily of fine sediment. Smaller streams are in many cases seasonal, and some are seeps that are associated with wetlands.

The riparian corridor varies from a width of 0 to 100 feet throughout the project area. Fish species that could use the waterways in the project vicinity include chinook salmon, cutthroat trout, steelhead, Pacific lamprey, Oregon chub, speckled dace, rainbow trout, and mountain whitefish. Most of the streams provide winter refuge habitat with some salmonid spawning habitat in the North Santiam River and below the project area in Mill Creek.

All stream or river reaches assessable to chinook or coho salmon in the project area are considered **essential fish habitat** (EFH) for these species. The proposed transmission line would span all rivers and streams.

### *3.7.2 Potential Impacts of the Proposed Action*

Potential impacts to wildlife would primarily occur within the ROW. The exception to this is that species sensitive to human activity may be temporarily displaced from habitats adjacent to the project area during construction. Removal of danger trees within or next to the ROW may result in a minor reduction of wildlife habitat available.

Species expected to be found most commonly in the project area are not sensitive to human disturbance, and many have adapted to existing with humans. Bats potentially occurring in the project area may be sensitive to human disturbance in the vicinity of roosting or hibernating sites or maternity colonies, which may occur in buildings, caves, or large, hollow trees. Danger tree removal may result in a minor reduction in the amount of bat roosting, hibernating, or maternity habitat if the trees felled are hollow or have loose bark that a bat can roost under.

Removal of danger trees may also result in a minor reduction in habitat available for cavity nesting bird species such as American kestrel, western bluebird, and both acorn and Lewis's woodpecker. One oak tree would be removed as a danger tree outside of the ROW. Removal of

one tree would not alter the character of the habitat for woodpecker species potentially occurring in the area.

Potential habitat removal would be limited to individual trees and would not greatly alter the amount of habitat available for wildlife species expected to occur in the project area. In addition, potential noise disturbance to species sensitive to human activity would be localized and temporary. As a result, impacts of the proposed project are expected to be minor.

Potential adverse impacts to fish that may occur with the proposed project include the following:

- Culvert installation, road rockings, replacing towers, and clearing of danger trees could potentially result in a temporary increase in sediment delivery and turbidity to adjacent waterways. About 15 culverts would be installed in waterways (6 in agricultural drainage ditches, 5 in road ditch lines, and 4 in streams). If fish are present in these waterways at the time of construction, increased turbidity could result in temporary displacement, reduced feeding efficiency, or injury.
- As with any construction project, there is a slight potential for accidental spills of petroleum products.
- Clearing of danger trees could potentially result in a slight decrease in riparian function along the North Santiam River and an unnamed tributary to Beaver Creek. However, the five cottonwood trees to be removed south of the North Santiam River are approximately 250 feet from the river and removal of these trees would have a very minor to no effect on riparian function.

With the mitigation measures proposed for this project, potential impacts to fish would be minor. Because the proposed project involves rebuilding an existing transmission line using the existing footprint and access roads in the ROW, operation and maintenance impacts would be minor and consistent with current practices.

### *3.7.3 Potential Impacts of the No Action Alternative*

The No Action Alternative would continue vegetation maintenance and clearing to maintain the ROW. BPA standard management practices, which are defined in the Transmission System Vegetation Management Environmental Impact Statement (DOE/EIS-0285, June 2000), would be applied to avoid or minimize potential impacts to wildlife and fish.

### *3.7.4 Threatened and Endangered Species*

The National Marine Fisheries Service (NMFS) and USFWS have identified one federally-listed endangered fish species (Oregon chub) and two federally-listed threatened fish species (Upper Willamette River chinook salmon and Upper Willamette River steelhead **evolutionarily significant units** [ESUs]) as potentially occurring in the project area. (See Table 3.) Based on information supplied by the Oregon State Department of Fish and Wildlife, the creeks in the project area have the potential to support chinook salmon and steelhead. According to the Natural Heritage Map (2001), chinook salmon and steelhead occupy the North Santiam River, Mill Creek, Beaver Creek, and the Pudding River. Critical habitat has been designated within

the project area for the Upper Willamette River chinook salmon ESU and the Upper Willamette River steelhead ESU. Specifically, juveniles of these two salmonid species probably use the waterways during winter flows for refuge habitat (Hunt, April 30, 2001).

Oregon chub are known to use some areas of the lower North Santiam River (Hunt, April 30, 2001). However, there are no identified populations of Oregon chub in the vicinity of the project.

The Upper Willamette River Basin has been identified as EFH for chinook and coho salmon. Because of the low level of earth disturbing activities and the mitigation measures included in the project (see Section 3.7.6), BPA has determined that the project would also not adversely affect EFH for chinook or coho salmon.

**Table 3-Federally-Listed Species**

<b>Species</b>	<b>Status</b>	<b>Occurrence in ROW</b>
Oregon chub	LE	No Documented Populations
Upper Willamette River chinook salmon	LT	Documented
Upper Willamette River steelhead	LT	Documented
bald eagle	LT	No Documented Populations
northern spotted owl	LT	No Documented Populations
Fender's blue butterfly	LE	No Documented Populations
Notes: LT=Federally-Listed threatened; LE=Federally-Listed endangered		
Sources: U.S. Fish and Wildlife Services Oregon State Office, October 27, 2000; Oregon Department of Fish and Wildlife, April 30, 2001		

Three other species listed as threatened or endangered by the USFWS could potentially occur in the project area: bald eagle, northern spotted owl, and Fender's blue butterfly. However, none of these species have been documented in the project area. (See Table 3.)

Potentially suitable perching or roosting habitat for bald eagles occurs next to the ROW where it crosses fish bearing streams, including the North Santiam River and Mill Creek.

Since forested areas adjacent to the ROW are second or third growth Douglas fir mixed with Garry oak, there is no suitable nesting or roosting habitat for northern spotted owls in the project area. This forested habitat could provide dispersal habitat for northern spotted owls; however, it is unlikely that they would use this area since the forested habitat is highly fragmented, occurs in small patches, and does not provide the continuous cover preferred by dispersing northern spotted owls.

One area of native upland vegetation has been identified within and adjacent to the ROW. This area may provide habitat for Fender's blue butterfly, though neither the butterfly nor its

known host plant, Kincaid's lupine (*Lupinus sulphureus kincaidii*), have been documented in this location.

### 3.7.5 Cumulative Impacts

The existing transmission line had an effect on fish and wildlife when the towers were installed in the early 1950s. There are no other ongoing or planned activities along the ROW being considered at this time. Should additions or expansions in the ROW or adjacent areas be planned, the activities could create additional impacts to fish and wildlife.

### 3.7.6 Mitigation for the Proposed Action

The principal potential impacts of the proposed project to aquatic species include delivery of fine sediment to streams from culvert installation, road rocking, tower assembly and erection, clearing to provide access to work areas, and accidental release of petrochemical contaminants to surface waters during project construction. Mitigation measures to be used under the proposed project seek to avoid or minimize all of these impacts.

The potential for these activities to affect salmonids (via runoff from the construction site) would be avoided or minimized through a number of mitigation measures that include limiting activities to existing access areas, establishing construction and vehicle maintenance setbacks from surface waters, using erosion and sediment control measures (silt fences, weed-free straw check dams, straw mulch), and reseeding disturbed areas. In addition to the mitigation measures noted above, BPA would implement the following measures to avoid and minimize potential impacts to aquatic species.

- To reduce disturbance to soils and vegetation, vehicle use would be restricted to access roads and some areas around and between towers, and topsoil would be left in roughened condition except in road shoulders.
- Erosion would be minimized by seeding disturbed nonagricultural areas with a plant seed mix, preferably in October or November.

To avoid the delivery of fine sediment to streams, the following measures would be used:

- Roadway drainage systems would be designed to control and disperse runoff (e.g., using outsloping roads, water bars, and ditches) to prevent erosion or slope stability problems.
- Erosion control measures such as silt fencing, straw mulch, straw bale check dams, and reseeding disturbed areas would be used to contain sediment within work areas. Special erosion control fabrics, such as matting, would be applied where soils and slopes have high erosion potential. In areas where towers are adjacent to waterways (miles 5, 7, 9, 10, 12, and 14), special erosion control fabrics, such as matting, would be applied to minimize erosion potential and sediment input to the streams.
- Access roads would be rocked where necessary.
- To the degree practical, construction would be avoided during wet weather to reduce rutting and soil loss.

- With the exception of the installation of culverts along unnamed tributaries to Valentine and Mill creeks and an unnamed tributary to the Pudding River, no construction activities would occur in water.
- All culvert installations in fish-bearing streams would be designed to be consistent with Oregon Department of Fish and Wildlife (ODFW) fish passage criteria (ODFW, 1997). When possible, all work would occur in dry conditions. All work that must be performed in flowing water would be completed during ODFW in-water work periods for the specific drainages or as negotiated with ODFW. All culvert installations would occur on waterways that are not identified stream reaches with threatened and endangered fish species. Any direct effect would consist of short-term turbidity due to construction activity, which would minimally affect fish downstream with work performed within the in-water work window and by implementing conservation measures to minimize any potential effects.

## 3.8 Wetlands

### 3.8.1 Affected Environment

Wetlands are transitional areas between well-drained uplands and permanently flooded aquatic habitats. Many wetlands are highly productive and support numerous complex food chains that represent valuable sources of energy to plants and animals. In addition, wetlands provide general and specialized habitat for a wide variety of aquatic and terrestrial animals. Many species depend upon wetlands for all or part of their life cycles (Mitsch and Gosselink, 1993).

Wetlands along the Santiam-Chemawa transmission line ROW were identified using National Wetland Inventory (NWI) maps, aerial photographs of the ROW, and field visits. A total of 14 wetlands were identified within the cleared ROW.

The 14 wetlands identified were classified into 3 wetland vegetation communities: **palustrine forested**, palustrine emergent, and **palustrine scrub-shrub**. Palustrine forested wetlands are characterized by woody vegetation that is 20 feet or more in height (Cowardin et al., 1979).

Palustrine emergent wetlands are shallow freshwater wetlands. They are characterized by erect, rooted, herbaceous hydrophytes (water-loving plants). In areas with relatively stable climatic conditions, emergent wetlands maintain the same appearance perennially (Cowardin et al., 1979).

Palustrine scrub-shrub wetlands are dominated by woody vegetation less than 20 feet tall. This vegetation includes true shrubs, young trees, and trees and shrubs that are small or stunted because of environmental conditions. Scrub-shrub wetlands may represent a successional state of a forested wetland, or may be relatively stable communities (Cowardin et al., 1979).

### *3.8.2 Potential Impacts of the Proposed Action*

The existing ROW has been disturbed by the original construction of the Santiam-Chemawa transmission line and by ongoing maintenance. The ROW has been previously cleared of trees for the transmission line towers. Towers for the new transmission line would be constructed within the footprint of the existing towers. With the mitigation measures proposed for this project, any potential impacts to wetlands are considered minor because the project activities would not permanently affect wetland functions.

### *3.8.3 Potential Impacts of the No Action Alternative*

This alternative would not require any construction, clearing, or new access. No impacts to wetland resources would occur beyond those already incurred from the existing line.

### *3.8.4 Cumulative Impacts*

The existing transmission line had an effect on wetlands when the towers were installed in the early 1950s. There are no other ongoing or planned activities along the ROW being considered at this time. Should additions or expansions in the ROW or adjacent areas be planned, the activities could create additional impacts to wetlands.

### *3.8.5 Mitigation for the Proposed Action*

To avoid and minimize potential impacts to wetlands in the project area, the following mitigation measures would be implemented:

- There would be no filling in wetlands without a permit from the U.S. Army Corps of Engineers.
- Topsoil would be immediately replaced following construction.
- Silt fencing would be placed between construction areas and sensitive resources to prevent sedimentation of those resources.
- Vehicles would be washed before entering the project area to avoid the spread of noxious weeds.
- Weed-free hay bales would be used for erosion control.
- All disturbed soils would be seeded following completion of construction.
- Construction equipment would be placed (stored) at least 150 feet from wetlands where possible.
- Construction equipment would be kept out of wetlands where possible.

## 3.9 Floodplains

### 3.9.1 *Affected Environment*

According to the Federal Emergency Management Agency (FEMA) flood hazard maps, the ROW crosses the 100-year floodplains of the Santiam River and a tributary to the Pudding River. The existing transmission line has not increased the potential for flooding or otherwise affected floodplain function.

### 3.9.2 *Potential Impacts of the Proposed Action*

Floodplain Management Executive Order 11988 mandates adverse impacts to floodplains must be avoided whenever there is a practical alternative. Where no practical alternative is available, impacts must be minimized.

One tower would be replaced on the north side of the North Santiam River within the 100-year floodplain. Two towers would be replaced at the edge of the 100-year floodplain of a tributary to the Pudding River. One would be located at the southeast edge of the floodplain; the other would be located at the northwest edge.

With the mitigation measures proposed for this project, any potential impacts to floodplains are considered minor because project activities would not affect floodplain function.

### 3.9.3 *Potential Impacts of the No Action Alternative*

This alternative would not require any construction or new access. No impacts to floodplains would occur beyond those already incurred from the existing line. Operation and maintenance impacts would be minor and consistent with current practices.

### 3.9.4 *Cumulative Impacts*

The existing transmission line did not affect floodplain function. There are no other ongoing or planned activities along the ROW being considered at this time. Should additions or expansions in the ROW or adjacent areas be planned, the activities could create additional impacts to the floodplain.

### 3.9.5 *Mitigation for the Proposed Action*

To avoid and minimize potential impacts to floodplains in the project area, the following mitigation measures would be implemented:

- All construction and clearing debris would be removed from within the floodplain boundary.
- To avoid delivering fine sediment into the stream channel, erosion control measures, including placement of silt fences and straw bales, revegetation and other stabilization measures would be used during construction.

## 3.10 Water Quality

### *3.10.1 Affected Environment*

Marion and Linn counties lie within the Willamette Valley. Annual precipitation averages approximately 40 inches. Temperatures range from an average of 40°F to 67 °F. The project is within the Molalla-Pudding and North Santiam River basins.

Groundwater is used for domestic, agricultural, and industrial uses. The North Santiam and Molalla-Pudding River basins are part of the Puget-Willamette trough regional aquifer system (USGS, 2000a). The main source of groundwater within the North Santiam River Basin is the Miocene basaltic-rock aquifer, which underlies 100 to 200 feet of unconsolidated deposits of sand and gravels and is considered the most productive aquifer within the Puget-Willamette trough regional aquifer system. The main aquifer source for groundwater in the Molalla-Pudding River Basin is the Puget-Willamette Lowland Aquifer System (USGS, 2000b).

Both the Molalla-Pudding and North Santiam River basins are considered Priority 1 on Oregon's 1998 Section 303(d) list (Oregon Department of Environmental Quality, 1998a) of water-quality-limited waterbodies for temperature (Oregon Department of Environmental Quality, 1998b). The Pudding River is also listed because of the presence of bacteria and DDT (Oregon Department of Environmental Quality, 1998b).

### *3.10.2 Potential Impacts of the Proposed Action*

Potential impacts to water quality from the proposed project are expected to be minor. Culvert installation, road rocking, tower assembly, and clearing of danger trees could potentially result in the delivery of fine sediment to streams, which could potentially result in temporarily increases in turbidity.

Hazardous materials associated with the project would be limited to substances commonly associated with construction equipment. This includes gasoline, diesel fuels, and hydraulic fluids. As with any construction project, there is a slight potential for accidental spills of petroleum products. The potential for these activities to affect water quality (via runoff from the construction site) would be avoided or minimized through a number of conservation measures.

Construction of the proposed project would not exacerbate existing water quality limitations in the Santiam or Pudding River drainages. Danger tree removal would not greatly affect temperature in these drainages and would not contribute bacteria, DDT, or other pollutants to surface waters.

Construction and operation of the double-circuit lines are not expected to affect groundwater quality. Shallow aquifers could experience minor short-term disturbances from changes in overland water flow and recharge caused by clearing and grading along the existing ROW. Near-surface soil compaction caused by heavy construction vehicles could reduce the soils' ability to absorb water. However, these impacts are not likely, as the access would be temporary and would occur primarily in agricultural fields where the land is plowed frequently as new crops are planted. Any minor impacts that could occur would be temporary.



### 3.10.3 *Potential Impacts of the No Action Alternative*

No impacts to water quality are expected to occur beyond existing conditions.

### 3.10.4 *Cumulative Impacts*

The proposed project is not expected to result in any cumulative effects on water quality. There are no known plans for nonfederal projects in the vicinity of the project that could affect water quality within the ROW. The project lies within agricultural and rural areas that are not likely to be developed in the foreseeable future.

### 3.10.5 *Mitigation for the Proposed Action*

Mitigation measures to avoid or minimize potential temporary effects to water quality are the same as those identified for vegetation, fish and wildlife (see Sections 3.6.6 and 3.7.6).

To avoid accidental release of petrochemical contaminants to surface waters, the following measures would be used:

- Mechanized equipment would be stored and maintained at least 150 feet from any surface water (stream or wetland).
- Mechanized equipment would be inspected daily for leaks and promptly repaired or replaced if leaking.
- A stormwater pollution prevention plan would be prepared and implemented.

## 3.11 Cultural Resources

### 3.11.1 *Affected Environment*

In the Willamette Valley two broad culture-historical stages are generally identified, the Paleoindian and the Archaic. The first refers to the earliest widely-recognized culture in the Americas. Paleoindian groups were probably nomadic or hunter-gatherers. The Archaic extends from 8000 B.P. (before present) to 200 B.P. and is characterized by a subsistence pattern that emphasized broad-based hunting with secondary emphasis on gathering (Minor et al., 1982). Groups in the study area and vicinity at the time of European contact include the Santiam band of the Kalapuya Indians, one of about 13 autonomous Kalapuya bands. Kalapuyan groups at the time of Euroamerican contact occupied all of the Willamette Valley from Willamette Falls (at present-day Oregon City) to the northern part of the Umpqua Valley. The Santiam and other Kalapuya bands were composed of a number of winter-village groups that shared a language dialect. Kalapuyan subsistence relied heavily on plant foods and game of all types.

In the early 1830s, retiring Hudson's Bay Company employees began to settle on the prairies along the Willamette River where they had previously trapped. Missionaries and the

early pioneer immigrants soon followed these early settlers in present-day Marion County. With the first settlements came mills, warehouses, roads, and ferry landings.

Howell Prairie, on the north end of the project area, was attractive to emigrants traveling west on the Oregon Trail who considered it suitable for diversified farming and stock raising. Howell Prairie was likely the result of Native American burning practices that facilitated open-game hunting grounds. With the arrival of other settlers on the Prairie in the 1840s, this location is considered one of the earliest agriculturally developed areas in the Willamette Valley.

### *3.11.2 Potential Impacts of the Proposed Action*

A cultural resource survey that included background literature and cartographic research and an archaeological field study of the Proposed Action was completed in May 2001. No prehistoric or historic-period archaeological sites have been recorded within a one-mile radius of the Proposed Action. An examination of General Land Office maps dating between 1852 and 1863 indicated that the Santiam-Chemawa transmission line crosses at least 22 Donation Land Claims (DLC) and that the ROW passes through or near two homesteads dating from 1855. No historic-period artifacts or features were observed at these sites. Shovel test probes also did not yield any historical artifacts. No archaeological or historical materials were observed on the ground surface at any of the tower locations or within the ROW between the towers. One prehistoric artifact was recovered from a shovel test probe within the footprint of one of the towers; however, the single artifact does not represent a cultural resource potentially eligible for listing in the National Register of Historic Places.

Based on existing evidence, BPA has made a determination that the Proposed Action would not affect archaeological or historic resources. Because the proposed project involves rebuilding an existing transmission line using the existing footprint and access roads in the ROW, operation and maintenance impacts would be minor and consistent with current practices. The Oregon State Historical Preservation Officer (SHPO) is reviewing this determination. BPA will not conclude this environmental process until it receives the SHPO's concurrence with the determination.

### *3.11.3 Potential Impacts of the No Action Alternative*

No impacts from the No Action Alternative are expected.

### *3.11.4 Cumulative Impacts*

The existing transmission line had an effect on cultural resources when the towers were installed in the early 1950s. There are no other ongoing or planned activities along the ROW being considered at this time. Should additions or expansions in the ROW or adjacent areas be planned, the activities could create additional impacts to cultural resources.

### *3.11.5 Mitigation for the Proposed Action*

No known archaeological sites or historic structures were identified during the archival research or the fieldwork phase of this project. In the unlikely event that cultural resources are

uncovered during construction, work in the immediate vicinity of the project would be halted, and BPA would consult with the Oregon State Historic Preservation Officer and a qualified archaeologist.

### 3.12 Public Health and Safety

#### 3.12.1 *Exposure to Electric and Magnetic Fields*

Everything electrical, including power lines, household wiring and appliances, produce electric and magnetic fields (EMF). Movement of electrons in a wire (**current**) produces magnetic fields, and electrical pressure (voltage) produces electric fields. Field strength decreases rapidly with distance.

EMF are found around any electrical wiring, including household wiring and electrical appliances and equipment. Throughout a home, the electric-field strength from wiring and appliances is typically less than 0.01 kilovolts per meter (kV/m). However, fields of 0.1 kV/m and higher can be found very close to some electrical appliances such as electric blankets.

Average magnetic-field strength in most homes (away from electrical appliances and home wiring, etc.) is less than 2 **milligauss (mG)**. Very close to appliances carrying high current, fields of tens or hundreds of milligauss can be present. Unlike electric fields, magnetic fields from outside power lines are not reduced in strength by trees and building materials. So, transmission or distribution lines can be a major source of magnetic-field exposure throughout a home located close to the line.

##### 3.12.1.1 Transmission Lines

Magnetic fields within transmission-line corridors constantly increase and decrease for a variety of reasons. If electric loads on a line increase, magnetic fields also increase. Magnetic fields are typically greatest in winter months, when electrical demands are highest. Operational, meteorological, and line design factors also affect magnetic fields. Fields are higher when the line is physically lower (closer to the ground) either because of design or because of higher temperatures. Since the voltage on transmission lines is relatively constant, the electric-field strength is dependent primarily on height above ground and is more constant than magnetic-field strength. Thus, predicting exact electric- and magnetic-field strengths involves uncertainty. Nevertheless, it is possible to estimate EMF for specific transmission-line conditions (maximum voltage, maximum load, and minimum height) that place upper limits on the field strengths that will actually be found under specific lines.

Information about EMF levels for the existing and proposed transmission lines in the project area are in Appendix A. Appendix A also describes how levels are determined.

##### 3.12.1.2 Regulations and Guidelines

There are no national standards for EMF from power facilities such as transmission lines. Oregon Energy Facility Siting Council (Oregon EFSC) has an electric field standard of 9 kV/m within the ROW. BPA has also set a maximum allowable electric field of 5 kV/m at the edge of

its rights-of-way and at road crossings. Additionally, BPA has set maximum allowable electric field strengths of 3.5 kV/m and 2.5 kV/m at shopping center parking lots and commercial/industrial lots, respectively. These levels are set to eliminate nuisance shocks. The Proposed Action would meet both Oregon's and BPA's electric field standards.

More information about standards is in Appendix A.

### 3.12.2 *Electric and Magnetic Field Effects*

Power lines, like electrical wiring, can cause serious electric shocks if certain precautions are not taken. These precautions include building the lines to minimize shock hazard. All BPA lines are designed and constructed in accordance with the National Electrical Safety Code (*NESC*). *NESC* specifies the minimum allowable distances between the lines and the ground or other objects. These requirements basically determine the edge of the ROW and the height of the line, that is, the closest point that houses, other buildings, and vehicles are allowed to the line.

People must also take certain precautions when working or playing near power lines. It is extremely important that a person not bring anything, such as a TV antenna or irrigation pipe, too close to the lines. The BPA provides a free booklet that describes safety precautions for people who live or work near transmission lines (*Living and Working Safely Around High-Voltage Power Lines*).

Possible effects associated with the interaction of EMF from transmission lines with people on and near a ROW fall into two categories: short-term effects that can be perceived and may represent a nuisance, and possible long-term health effects. Short and long-term effects of the Proposed Action are discussed in detail in Appendix A.

The issue of whether there are long-term health effects associated with transmission-line fields is controversial. In recent years, considerable research on possible biological effects of EMF has been conducted. A review of these studies and their implications for health-related effects is provided in Appendix B. Also, the Department of Energy (DOE) provides a free booklet that describes safety precautions for people who live or work near transmission lines (*Questions and Answers about EMF Electric and Magnetic Fields Associated with the Use of Electric Power*).

There are no national standards for electric or magnetic fields. The proposed project would meet BPA's and Oregon's electric field standard.

Predicted levels for electric and magnetic fields were calculated for the Proposed Action. Appendix A describes how the calculations were done and the predicted values in more detail.

#### 3.12.2.1 Calculated Values for Electric Fields

The calculated peak electric field expected on the ROW of the proposed line is 2.5 kV/m when there are no parallel lines. The peak values would be present only at locations directly under the line, near mid-span, where the conductors are at the minimum clearance. The conditions of minimum conductor clearance at maximum current and maximum voltage occur very infrequently. The calculated peak levels are rarely reached under real-life conditions, because the actual line height is generally above the minimum value used in the computer model,

because the actual voltage is below the maximum value used in the model, and because vegetation within and near the edge of the ROW tends to shield the field at ground level. Maximum electric field under the existing parallel McNary-Santiam 500-kV line is 8.1 kV/m.

The largest values expected at the edge of the ROW nearest the proposed line would be 0.4 kV/m. For the parallel configuration, the field at the edge of the ROW nearest the 500-kV line would be 0.3 kV/m. The largest electric fields at the edges of the existing rights-of-way are 1.3 and 2.6 kV/m for the 230- and 500-kV lines, respectively.

The electric fields associated with the Santiam-Bethel line can be compared with those found in other environments. Sources of 60-Hertz (Hz) electric (and magnetic) fields exist everywhere electricity is used; levels of these fields in the modern environment vary over a wide range. See Appendix A for more detail.

### 3.12.2.2 Calculated Values for Magnetic Fields

Field values on the ROW and at the edge of the ROW were calculated for the projected maximum currents during winter peak load in 2006, for minimum and average conductor clearances. The actual magnetic-field levels would vary as currents on the lines change daily and seasonally and as ambient temperature changes. Average currents over the year would be about 60 percent of the maximum values. The levels represent the highest magnetic fields expected for the proposed Santiam-Bethel/Santiam-Chemawa 230-kV line. Average fields over a year would be considerably reduced from the peak values as a result of increased clearances above the minimum value and reduced currents from the maximum value.

The maximum calculated 60-Hz magnetic field expected at 3.28 ft. (1 m) above ground for the proposed line is 87 mG for the proposed line alone and 94 mG when the line parallels the 500-kV line. This field is calculated with the conductors at a minimum height of 31 ft. (9.5 m). The maximum field would decrease for increased conductor clearance. For an average conductor height over a span of 43 ft. (13.1 m), the maximum field would be 50 mG and 58 mG for the proposed line alone and parallel to the 500-kV line, respectively.

At the edge of the ROW of the proposed line, the calculated magnetic field for maximum current load conditions is 26 mG. When the line is located parallel to the existing 500-kV line, the field at the edge of the ROW adjacent to the proposed line would be 29 mG.

The magnetic field falls off rapidly as distance from the line increases. At a distance of 200 ft. from the centerline of the proposed line, the field would be 4 mG for maximum current conditions. The calculated magnetic field for maximum current would be less than 10 mG at about 120 ft. from the centerline. For the existing lines, the peak magnetic fields on the rights-of-way are 218 mG and 108 mG, for the 230- and 500-kV lines, respectively. Fields at the edges of the existing rights-of-way are 78 mG and 50 mG for the 230- and 500-kV lines, respectively. Addition of the proposed line would not greatly change the magnetic fields under, or at the edge of, the ROW of the existing 500-kV line.

The magnetic fields associated with the proposed Santiam-Bethel 230-kV line can be compared with fields from other sources. The range of 60-Hz magnetic-field exposures in publicly accessible locations such as open spaces, transmission-line rights-of-way, streets, pedestrian walkways, parks, shopping malls, parking lots, shops, hotels, public transportation, and so on range from less than 0.1 mG to about 1 G, with the highest values occurring near small

appliances with electric motors. In occupational settings in electric utilities, where high currents are present, magnetic-field exposures for workers can be above 1 G. At 60 Hz, the magnitude of the natural magnetic field is approximately 0.0005 mG. See Appendix A for more detail.

### 3.12.3 Noise and Radio/Television Interference

#### 3.12.3.1 Audible Noise

Noise impacts result from construction activities and from the operation of the transmission facilities. Construction noise is short-term and typically does not result in any serious disturbance to residents.

Noise produced by transmission line **corona** is a hissing, popping or crackling sound. It is primarily associated with lines of 345-kV and above. A 120-Hz “hum” is also occasionally superimposed on the corona-generated noise. The sound level depends on the ambient noise level, conductor and structure geometry, operating voltage, and the weather. Audible noise from transmission lines increases in wet weather.

The Noise Control Act of 1972 gives the states the responsibility for noise control. Environmental noise limits applicable to this project are regulated by Oregon Administrative Rules (OAR 340.35). Corona-generated audible noise from the proposed line would be similar to noise from the existing 230-kV line and less than that from the existing 500-kV transmission lines. Audible noise levels would be in compliance with noise regulation in Oregon.

BPA may use implosive fittings to connect one reel of conductor to another. These explosive devices are set off causing the fitting to tighten around the conductors. This provides a very solid connection. A temporary loud boom can be heard when the fittings explode. BPA would notify nearby landowners if these fittings are going to be used on the project.

#### 3.12.3.2 Radio and Television Interference

Corona occurs where high electric field strength on conductors, insulators, and hardware imparts sufficient energy to charged particles to cause ionization (molecular breakdown) of the air. Corona may interfere with radio and television reception by generating a high-frequency noise called electromagnetic interference (EMI). EMI is a static sometimes heard over an automobile radio when driving beneath high-voltage lines. It is usually associated with higher voltage lines, i.e., 345-kV and above. Corona activity also produces audible noise. (See **Audible Noise** above.)

Federal Communications Commission (FCC) regulations require that incidental radiation devices (such as transmission lines) be operated so that radio and television reception will not be seriously degraded or repeatedly interrupted. Further, FCC regulations require that the operators of these devices mitigate such interference. Corona-generated EMI from the proposed line would be less than that from the existing 230-kV line on the corridor and would remain below limits identified as acceptable. Overall, BPA receives very few radio interference (RI) or television interference (TVI) complaints. None are anticipated for this project. BPA will mitigate those instances where an engineering study has determined that harmful interference exists as a result of BPA’s facilities.

#### *3.12.4 Fire*

Fires on or near the ROW can jeopardize safe and reliable operation of transmission lines. Besides physical damage from heat and flames, smoke and hot gases from a fire can cause arcing between lines, between lines and structures, or between lines and the ground. Such occurrences can pose a threat to the safety of personnel in the vicinity, such as firefighters, and can result in line outages.

To prevent fires and other hazards, safe clearances are maintained between the tops of trees and the existing lines. Electricity can arc from the conductor to a treetop. Generally, trees are not allowed to grow over 20 feet high on the ROW. Trees and tall brush are removed periodically from the ROW as part of maintenance activities. BPA also prohibits storage of flammable material on rights-of-way.

Transmission structures may be struck by lightning. Because the structures are electrically grounded, the current from the lightning strike passes directly into the ground with minimal risk of starting a fire.

Because the proposed project would rebuild an existing transmission line on the same ROW, no new fire hazards or risks are expected to occur beyond those already present from the current transmission line.

#### *3.12.5 Potential Impacts of the No Action Alternative*

No impacts are expected to occur to public health and safety beyond those already taking place from the existing line.

#### *3.12.6 Mitigation for the Proposed Action*

Mitigation actions to protect public health and safety include:

- Design the Proposed Action to meet Oregon EFSC and BPA electric field standards.
- Maintain safe clearances between trees and transmission lines to prevent fires and other hazards.
- Ground all transmission structures to minimize fire risk.
- Require the construction contractor to develop an emergency response plan that includes responding to a potential accidental fire during construction.
- Design the line to meet Oregon EFSC requirements for noise where the line is parallel to existing 500-kV lines.
- Rectify any TV/radio interference caused by the proposed project.





## 4.0 Environmental Consultation, Review, and Permit Requirements

### 4.1 National Environmental Policy Act

This environmental assessment was prepared according to NEPA (42 USC 4321 et seq.). NEPA is a national law for protection of the environment. NEPA applies to all federal projects or projects that require federal involvement. BPA considers potential environmental consequences and would take action to protect, restore, and enhance the environment.

### 4.2 Threatened and Endangered Species

The Endangered Species Act of 1973 (ESA), as amended, requires that federal agencies ensure that their actions do not jeopardize threatened or endangered species and their critical habitats; it also gives review authority to USFWS and NMFS. Sections 3.7.2 and 3.6.2 discuss potential impacts to threatened and endangered species from the proposed project.

BPA is consulting with both USFWS and NMFS on the impacts of the project to threatened and endangered species. A **Biological Assessment** has been prepared to evaluate the potential effect of the project on threatened and endangered species. The BA was prepared to evaluate the potential of the project to adversely affect the bald eagle, northern spotted owl, Fender's blue butterfly, the Upper Willamette River chinook salmon ESU, the Upper Willamette River steelhead ESU, Oregon chub, Nelson's checker-mallow, Bradshaw's lomatium, Willamette daisy, golden Indian paintbrush, water Howellia, and Kincaid's lupine. The BA was submitted to the NMFS and the USFWS for concurrence with BPA's determination of effect on federally-listed species under Section 7 of the Endangered Species Act. BPA would employ best management practices and the mitigation measures identified in the BA and this EA to reduce the potential disturbance to native plant communities, to reduce the potential for erosion and sedimentation, and to prevent the introduction of harmful chemicals in all surface waters associated with these species.

**Plants** – Potential effects to federally-listed plant species could occur if areas of documented habitat or potential habitat were disturbed or altered during the construction of the project. The only area of documented or potential habitat for these species in the project area is a wetland located in mile 7. BPA would avoid disturbance to this area during construction by limiting access of construction equipment from the area and including mitigation measures to prevent the spread of nonnative plant species. With these mitigation measures in place, the potential to affect habitat for these species is minor.

**Animals** – According to the Oregon Department of Fish and Wildlife Natural Heritage data, no bald eagle nests are located within 1/2 mile of the project ROW. This distance is the typical distance at which impacts to nest sites are evaluated, as mandated by the Pacific States Bald Eagle Recovery Plan (USFWS, 1986). Since no known bald eagle nesting or winter roosting/foraging habitat occurs in the project vicinity, direct impacts to either nesting bald eagles or bald eagle roosting or foraging behaviors are not expected to occur as a result of project implementation.

Removal of danger trees within the riparian areas of fish bearing streams could result in a loss of potential perch trees for roosting or foraging bald eagles in these areas. Bald eagle foraging habitat within the project area is expected to occur primarily on the North Santiam River and Mill Creek, both of which are known to support adult salmon in the vicinity of the project. However, the selective tree removal south of the North Santiam River would affect only a small portion of the available trees and would not make the potential habitat unsuitable. Eagles potentially using these areas during project implementation could be temporarily displaced due to construction activity. However, temporary displacement of eagles would be a minor impact.

The project area does not cross any known spotted owl home range territories, is not located within critical habitat for this species, and does not contain suitable nesting or foraging habitat for spotted owls. Project implementation would not alter or remove any suitable spotted owl habitat. Selective removal of danger trees along the ROW would include trees within forested areas that may serve as spotted owl dispersal habitat. However, since this would only occur along the edge of the previously cleared ROW, it would not alter the habitat in such a way as to make it unsuitable. For these reasons, no direct impacts on spotted owls or their habitats are expected to occur in conjunction with this project.

The only potential habitat for Fender's blue butterfly in the project area is the area of upland native plant communities in mile 7. Since all towers are scheduled for replacement, ground disturbance would occur in the vicinity of this area. If this area is disturbed, potential direct impacts to Fender's blue butterfly could include alteration or loss of potential habitat and potential mortality of individuals. Alteration of native plant communities documented in the vicinity of mile 7 in conjunction with project implementation would alter potential habitat for this species. BPA would avoid disturbance to areas of native vegetation by limiting ground disturbance within the area of known native vegetation and limiting construction activities and access to locations within the previously disturbed site of the tower footprint, existing roads, and areas outside of the patch of native vegetation.

BPA has also included mitigation measures to prevent the spread of non-native plant species. With these mitigation measures in place, the potential to affect Fender's blue butterfly or its potential habitat is minor.

Potential impacts to threatened and endangered fish species are consistent with the potential impacts to all fish species (i.e., increased turbidity, sediment delivery, decreased shading) as discussed in Section 3.7.2. With the mitigation measures proposed for this project, these potential impacts to threatened and endangered fish would be minor.

In conclusion, based on a review of the latest federal threatened and endangered species lists, review of habitat requirements, and use of project mitigation measures proposed in the BA and this EA, it is BPA's opinion that the proposed project "may affect but is not likely to adversely affect" all the listed species that may be present in the project area except the northern spotted owl. It is BPA's opinion that the proposed project would have "no effect" on the northern spotted owl.

See also Section 3.7.4.

### 4.3 Fish and Wildlife Conservation

The Fish and Wildlife Conservation Act of 1980 (16 USC 2901 et seq.) encourages federal agencies to conserve and promote conservation of non-game fish and wildlife species and their habitats. In addition, the Fish and Wildlife Coordination Act (16 USC 661 et seq.) requires federal agencies undertaking projects affecting water resources to consult with the U.S. Fish and Wildlife Service and the state agency responsible for fish and wildlife resources. The analysis in Section 3.7, Fish and Wildlife, indicates that the alternatives would have no to low impacts to fish and wildlife.

#### 4.3.1 *Essential Fish Habitat*

Public Law 104-297, the Sustainable Fisheries Act of 1996, amended the Magnuson-Stevens Fishery Conservation and Management Act (Magnuson-Stevens Act) to establish new requirements for "Essential Fish Habitat" descriptions in federal fishery management plans and to require federal agencies to consult with NMFS on activities that may adversely affect EFH. The Magnuson-Stevens Act requires all fishery management councils to amend their fishery management plans to describe and identify EFH for each managed fishery. The Pacific Fishery Management Council has issued such an amendment in the form of Amendment 14 (1999) to the Pacific Coast Salmon Plan. This amendment covers EFH for all fisheries under NMFS' jurisdiction that would potentially be affected by the Proposed Action. Specifically, these are the chinook and coho salmon fisheries. EFH includes all streams, lakes, ponds, wetlands, and other currently viable water bodies and most of the habitat historically accessible to salmon. Activities occurring above impassable barriers that are likely to adversely affect EFH below impassable barriers are subject to the consultation provisions of the Magnuson-Stevens Act.

Under the Magnuson-Stevens Act, NMFS must be consulted by any federal agency undertaking, permitting, or funding activities that may adversely affect EFH, regardless of its location. Under section 305(b)(4) of the act, NMFS is required to provide EFH conservation and enhancement recommendations to federal and state agencies for actions that adversely affect EFH. Wherever possible, NMFS uses existing interagency coordination processes to fulfill EFH consultations with federal agencies. For the Proposed Action, this goal would be met by incorporating EFH consultation into the Endangered Species Act Section 7 consultation. The proposed project would neither destroy nor adversely modify critical habitat for chinook salmon or steelhead, or EFH for chinook or coho salmon.

#### 4.3.2 *Migratory Bird Treaty Act*

The Migratory Bird Treaty Act (16 U.S.C. 703-712, July 3, 1918, as amended 1936, 1960, 1968, 1969, 1974, 1978, 1986 and 1989) (MBTA) implements various treaties and conventions between the United States and other countries, including Canada, Japan, Mexico, and the former Soviet Union, for the protection of migratory birds. Under the act, "taking," killing, or possessing migratory birds or their eggs or nests is unlawful. Most species of birds are classified as migratory under the act, except for upland birds such as pheasant, chukar, and gray partridge.

The Act allows few exemptions, such as waterfowl hunting. Many types of development result in the taking of migratory birds: collision with windows, for example, is a leading cause of

death among songbirds. Taking may be allowed under a scientific permit if research is deemed beneficial to migratory birds.

Construction, operation and maintenance of the proposed project may result in some impacts to birds. Some of the potentially impacted bird species are protected under the Migratory Bird Treaty Act. There are presently no permits available to federal agencies for “incidental take” such as would result from the proposed transmission line project. The Department of Energy is presently negotiating a MBTA Memorandum of Agreement with the USFWS that is expected to include avian mortality due to transmission system impacts. Potential impacts to migratory birds include loss of habitat. Impacts would be limited to individuals potentially nesting in the area and would be incidental to the action. The reduction in nesting habitat for these species is expected to be minor. BPA would ensure appropriate mitigation measures are employed to reduce the risk of mortality to a minimum.

#### 4.4 Cultural and Historical Resources

##### *4.4.1 National Historic Preservation Act*

The National Historic Preservation Act (1966, 16 U.S.C. 470) requires Federal agencies to take into account the potential effects of their undertakings on properties on or eligible for the National Register of Historic Places. Based on the result of the background research and field investigations, the proposed project would not adversely affect any cultural resources.

##### *4.4.2 Archaeological Resources Protection Act*

The Archaeological Resources Protection Act prohibits excavation, removal, damage, or other alteration or defacement of archeological resources on federal or Indian lands without a properly issued permit. Based on the result of the background research and field investigations, the proposed project would not adversely affect any cultural resources.

##### *4.4.3 American Indian Religious Freedom Act*

The American Indian Religious Freedom Act requires federal land managers to include consultation with traditional Native American religious leaders in their management plans and guarantees First Amendment rights for traditional religions. Based on the result of the background research and field investigations, the proposed project would not adversely affect any cultural resources.

##### *4.4.4 Historic Sites Act*

The Historic Sites Act of 1935, the basis for the National Historic Landmarks Program, provides for the preservation of historic American sites, buildings, objects and antiquities of national significance. Based on the result of the background research and field investigations, the proposed project would not adversely affect any cultural resources.

#### 4.4.3 *Native American Graves Protection and Repatriation Act*

The Native American Graves Protection and Repatriation Act of 1990 (PL101-601) recognizes the property rights of Native Americans in certain cultural items, including Native American human remains, funerary objects, sacred objects, and items of cultural patrimony. In cases involving the inadvertent discovery of Native American human remains or defined cultural items during activities occurring on federal or tribal lands, the activity must be halted temporarily, the items protected, and the appropriate federal agency and tribal authority notified of the discovery.

Based on the results of the background research and field investigations, the proposed projects would not adversely affect any cultural resources.

#### 4.5 State, Areawide, and Local Plan and Program Consistency

This project does not fall within the coastal zone of the state of Oregon. BPA has no federal obligation to obtain state and local permits, but the agency would strive to meet or exceed the substantive standards and policies of state and local planning jurisdictions.

#### 4.6 Floodplains and Wetlands Protection

##### 4.6.1 *Floodplain/Wetland Assessment*

Department of Energy regulations on compliance with Floodplain/Wetlands environmental review requirements (10 CFR 1022.12) and Federal Executive Orders 11988 and 11990 require BPA to prepare an assessment of the impacts of the alternatives on floodplains and wetlands. BPA published a notice of floodplain/wetland involvement for this project in the *Federal Register* on May 11, 2001. An assessment of wetland impacts is provided in Section 3.8, Wetlands and Section 3.9, Floodplains.

#### 4.7 Farmland Protection Policy Act

The Farmland Protection Policy Act (7 U.S.C. 4201 et seq.) directs federal agencies to identify and quantify adverse impacts of federal programs on farmlands. The Act's purpose is to minimize the number of federal programs that contribute to the unnecessary and irreversible conversion of agricultural land to non-agricultural uses.

An evaluation of soil survey information for the existing transmission line ROW indicated that the majority of the ROW in Linn and Marion counties, Oregon, is located in prime farmland soils. The proposed project would be constructed entirely in an existing ROW, and within existing structure footprints, except in one location where 3 new poles would be installed to facilitate crossing under other existing utilities. The 3 new poles would be installed in existing ROW. Therefore, no designated prime, unique, or other farmland of statewide importance outside of the existing ROW would be converted under the proposed action. Evaluation of the project according to the criteria set forth in the Act indicates the Proposed Action would be in compliance with the Act and would have little or no impact on area farmlands.

## 4.8 Discharge Permits under the Clean Water Act

The Clean Water Act (CWA) regulates discharges into waters of the United States. The following sections of the CWA could potentially apply to this project.

### 4.8.1 Federal

**Section 401** – The Water Quality Certification program requires that states certify compliance of federal permits and licenses with state water quality standards. A federal permit to conduct an activity that results in discharges into waters of the United States, including wetlands, is issued only after the affected state certifies that existing water quality standards would not be violated if the permit were issued. For this project, the Oregon Department of Environmental Quality would review necessary permits for compliance with state water quality standards.

**Section 402** – This section authorizes stormwater discharges associated with industrial activities under the National Pollutant Discharge Elimination System (NPDES). For Oregon, the EPA has a general permit authorizing federal facilities to discharge stormwater from construction activities disturbing land of 5 or more acres into waters of the United States, in accordance with various set conditions. BPA would comply with the appropriate conditions for this project and would prepare a Storm Water Pollution and Prevention (SWPP) plan. The plan helps ensure that erosion control measures would be implemented and maintained during construction. It also addresses best management practices for stabilization, stormwater management, and other controls.

**Section 404** – Authorization from the Corps of Engineers is required in accordance with the provisions of Section 404 when dredged or fill material is discharged into waters of the United States, including wetlands. This includes excavation activities that result in the discharge of dredged material that could destroy or degrade waters of the United States.

The construction and upgrade of access roads could potentially impact waters of the United States. New poles and other structures would be located outside wetland boundaries where possible. Field surveys have been conducted to identify wetlands and ensure compliance. If permits are necessary, authorization would be sought from the Corps and appropriate state agencies.

### 4.8.2 State

The Oregon Division of State Lands administers the Removal-Fill Law that requires a permit for removal, fill, or alteration involving 50 cubic yards or more of material in any water of the state including wetlands. Appropriate permits would be applied for if necessary for this project. See Section 4.14.

#### 4.9 Permits for Structures in Navigable Waters

The proposed project would not involve construction, removal, or rehabilitation of any structures in navigable waters. BPA transmission towers would span all water sources.

#### 4.10 Noise Control Act

The Federal Noise Control Act of 1972 (42 U.S.C. 4903) requires that federal entities, such as BPA, comply with state and local noise requirements. See Section 3.12, Public Health and Safety.

#### 4.11 Global Warming

The proposed project would clear 14 danger trees including nine cottonwoods, one Douglas fir, one Lombardi poplar, one oak, and one Oregon ash. These trees and plants would change from collectors of carbon to emitters of carbon in the form of carbon dioxide (a greenhouse gas) as they degrade rather than grow. The Proposed Action's contribution to global warming would be minor because the amount of tree clearing would be small and because low-growing vegetation would naturally revegetate cleared areas.

#### 4.12 Executive Order on Environmental Justice

In February 1994, Executive Order 12898, entitled *Federal Actions to Address Environmental Justice in Minority and Low-income Populations*, was released to federal agencies. This order directs federal agencies to incorporate environmental justice as part of their missions. As such, federal agencies are specifically directed to identify and address, as appropriate, disproportionately high and adverse human health or environmental effects of their programs, policies, and activities on minority and low-income populations.

This action has been evaluated for potential disproportionately high environmental effects on minority and low-income populations (see Section 3.2, Socioeconomics). There would be a low human health or environmental impact on minority and low-income populations from the proposed project.

#### 4.13 Resource Conservation and Recovery Act

No hazardous waste products would be used, discarded or produced by this project. Solid wastes would be disposed of at an approved landfill or recycled.

#### 4.14 State Agency Authorities and Regulations

The **State Removal/Fill Law (ORS 196.810)** – The Removal/fill law requires that a permit be obtained from the Division of State Lands for either placing 50 cubic yards (or more) of fill into or removed from waters of the U.S. The applicant would state the nature and quantity of fill or material to be removed, together with the location, time and method to be used. If permits are necessary, authorization would be sought from the Corps and appropriate state agencies.

The **State Air and Water Quality Standards** – The proposed project would not affect the chemical or biological characteristics of water in the area. It would be designed to comply with local ordinance, laws, and state water quality programs so as not to degrade the quality of shoreline areas or adjacent surface waters. (See also Section 3.10, Water Quality.)

The proposed project's contribution to global warming would be minor due to the small amount of tree clearing that would be required, and the cleared areas would be revegetated with low-growing plants.

#### 4.15 Safe Drinking Water Act

The Safe Drinking Water Act (42 U.S.C. Section 300f et seq.) is designed to protect the quality of public drinking water and its sources. BPA would comply with state and local public drinking water regulations. The proposed project would not affect any sole source aquifers or other critical aquifers, or adversely affect any surface water supplies.

#### 4.16 Federal Insecticide, Fungicide, and Rodenticide Act

It is unlikely that herbicides would be used during project construction. However, herbicides might be used occasionally to maintain the ROW. Only EPA-approved herbicides would be used, selectively applied by licensed applicators according to label instructions. For more information on BPA's proposed vegetation management program, see BPA's Transmission System Vegetation Management Program Final Environmental Impact Statement (DOE/EIS-0285, June 2000) for a thorough discussion of compliance with pertinent standards.

#### 4.17 Toxic Substances Control Act

No toxic substances would be manufactured or used on this project.

#### 4.18 Clean Air Act

The proposed project would not result in emissions remaining under BPA control. No burning would take place as a result of the proposed project. Trees and slash that are cleared would not be burned. Vehicles used during the construction of the proposed project would be properly maintained so as to minimize emissions.

#### 4.19 Permits for Rights-of-Way on Public Lands

No additional easements or permits for rights-of-way on federal or state lands would be required. BPA would coordinate with landowners before conducting any activities outside the ROW boundaries.

#### 4.20 Energy Conservation at Federal Facilities

The Proposed Action would not require any new buildings.



#### 4.21 Notice to the Federal Aviation Administration

As part of transmission line design, BPA seeks to comply with Federal Aviation Administration (FAA) procedures. Final locations of towers, tower types, and tower heights are submitted to FAA for the project. The information includes identifying towers taller than 200 feet above ground, and listing all towers within prescribed distances of airports listed in the FAA airport directory. BPA also assists the FAA in field review of the project by identifying tower locations. The FAA then conducts its own study of the project, and makes recommendations to BPA for airway marking and lighting. General BPA policy is to follow FAA recommendations. At the North Santiam River crossing, marker balls would be installed on the conductor to make it more visible to pilots.



## 5.0 Persons and Agencies Consulted

### 5.1 Federal Agencies

United States Fish and Wildlife Service  
National Marine Fisheries Service  
United States Army Corps of Engineers

### 5.2 State Agencies

Oregon State Office of Archaeology and Historic Preservation  
Oregon Department of Fish and Wildlife  
Oregon Department of Environmental Quality  
Oregon Division of State Lands  
Oregon Department of Land Conservation and State Lands  
Energy Facility Siting Council, Oregon Department of Energy  
Oregon Department of Transportation

### 5.3 Local Agencies

Linn County Planning and Building Department  
Marion County Planning and Building Department  
Marion County Department of Community Development

### 5.4 Tribes

Confederated Tribes of Grand Ronde

### 5.5 Utilities

Portland General Electric

### 5.6 Landowners

There are approximately 100 landowners on the mailing list.



## 6.0 References

- Applied Archaeological Research. May 22, 2001. Results of a Cultural Resources Survey of the Bonneville Power Administration's Santiam-Bethel Tap Transmission Line Project, Marion County, Oregon. (Applied Archaeological Research Report No. 181) Portland, OR. Prepared for Bonneville Power Administration, Portland, OR.
- Bonneville Power Administration. 2000. Transmission system vegetation management program. Final environmental impact statement. DOE/EIS-0285. Portland, OR.
- Bracken, T. Dan. June 2001. Santiam-Bethel Transmission Project, *Appendix A, Electrical Effects*.
- Cowardin, L. M., V. Carter, F. C. Golet, and E. T. LaRoe. 1979. Classification of wetlands and deep water habitats of the United States. (FWS/OBS-79/31.) U.S. Fish and Wildlife Service. Washington, DC.
- Fennimore, Joe. June 8, 2001. Associate Planner, Marion County Community Development Department. Telephone conversation..
- Hopkins, S. Planner. May 1, 2001. Linn County Planning Department, OR. Telephone conversation.
- Hunt, W. April 30, 2001. Assistant district fish biologist. Oregon Department of Fish and Wildlife, Corvallis, OR. Telephone conversation.
- Jones & Stokes. May 17, 2001. Upgrade to the Bonneville Power Administration Santiam to Bethel, Oregon transmission line. Draft biological assessment. (J&S 0P008.01.) Bellevue, WA. Prepared for Bonneville Power Administration, Portland, OR.
- Linn County, Oregon. 2000. Linn County parks. Available: <<http://www.co.linn.or.us/>>. Accessed May 8, 2001.
- \_\_\_\_\_. 2001. Recreational facilities. Available: <<http://www.co.linn.or.us/>>. Accessed April 20, 2001.
- Marion County, Oregon. 2001. Recreational facilities. Available: <<http://www.co.marion.or.us>>. Accessed April 20, 2001.
- Maser, C. 1998. Mammals of the Pacific Northwest: from the coast to the high Cascades. Oregon State University Press. Corvallis, OR.
- McMaster, K. State Supervisor, USFWS Oregon State Office, Portland, OR. October 27, 2000 – letter to Leslie Kelleher of Bonneville Power Authority.
- Mitsch, W.J., and J.G. Gosselink. 1993. Wetlands. International Thomson Publishing. New York, NY.
- ODFW (Oregon Department of Fish and Wildlife). 1993. Oregon wildlife diversity plan. Portland, OR.

- ODFW. 1997. Oregon Department of Fish and Wildlife guidelines and criteria for stream-road crossings. Portland, OR.
- Oregon Department of Environmental Quality. 1998a. Map of 303(d) listed waterbodies and sub basin priorities. Available: <<http://waterquality.deq.state.or.us/WQLData/303dListMap.htm>>. Accessed April 26, 2001.
- Oregon Department of Environmental Quality. 1998b. Final 1998 303(d) file download page. Available: <<http://waterquality.deq.state.or.us/wq/303dlist/Download303d.htm>>. Accessed. April 26, 2001.
- Oregon Labor Market Information System. 2001. Oregon Employment Department unemployment and poverty statistics. Available: <<http://www.olmis.org>>. Accessed April 16, 2001.
- Oregon Natural Heritage Program. 2001. Natural Heritage database. Portland, OR.
- Oregon State University. 1997a. Oregon agriculture census, Linn County, 1997. Available: <<http://govinfo.library.orst.edu/cgi-bin/ag-list?01-043.orc>>. Accessed May 10, 2001.
- \_\_\_\_\_. 1997b. Oregon agriculture census, Linn County, 1997. Available: <<http://govinfo.library.orst.edu/cgi-bin/ag-list?28-043.orc>>. Accessed May 10, 2001.
- \_\_\_\_\_. 1997c. Oregon agriculture census, Marion County, 1997. Available: <<http://govinfo.library.orst.edu/cgi-bin/ag-list?01-047.orc>>. Accessed May 10, 2001.
- \_\_\_\_\_. 1997d. Oregon agriculture census, Marion County, 1997. Available: <<http://govinfo.library.orst.edu/cgi-bin/ag-list?28-047.orc>>. Accessed May 10, 2001.
- Oregon State University, Agricultural Extension. 1999. Oregon State University Extension agricultural statistics, Linn County, last updated April 23, 2001. Available: <<http://oregonstate.edu/extension/linn/Agstats1.html>>. Accessed May 10, 2001.
- Oregon State University, Extension Economic Information Office. 1999. Marion County agricultural commodity sales, 1999 (preliminary), last updated April 18, 2000. Available: <<http://www.open.org/~mcboc/agsales.htm>>. Accessed May 10, 2001.
- Portland State University Population Research Center. 2000. Population, ethnic, gender, and age distribution. Available: <<http://www.upa.pdx.edu/CPRC/>>. Accessed April 11, 2001.
- Salem OnLine. 2000. Salem OnLine. Available: <<http://www.salemlodging.com/index.html>>. Accessed May 8, 2001.
- U.S. Bureau of the Census. 1997. 1997 Model-based income and unemployment estimates. Available: <<http://www.census.gov>>. Accessed April 10, 2001.
- \_\_\_\_\_. 2000. 1999 unemployment rates. Available: <<http://www.census.gov>>. Accessed April 10, 2001.
- U.S. Bureau of Economic Analysis. 1998. Regional accounts data, employment sectors, annual earnings by industry sector, income and unemployment. Available: <<http://www.bea.doc.gov/bea/regional/reis/ca05>>. Accessed April 18, 2001.

USFWS (U.S. Fish and Wildlife Service). 1986. Recovery plan for the Pacific bald eagle. USDI Fish and Wildlife Service, Portland, OR.

USGS. 2000a. Groundwater atlas of the United States: Idaho, Oregon, and Washington. HA730-H. Available: <[http://capp.water.usgs.gov/gwa/ch\\_h/jpeg/H083.jpeg](http://capp.water.usgs.gov/gwa/ch_h/jpeg/H083.jpeg)>. Accessed April 30, 2001.

\_\_\_\_\_. 2000b. 1990 water use. Available: <<http://water.usgs.gov>>. Accessed April 30, 2001.

Wheeldon, Robert. June 6, 2001. Associate Planner, Linn County Planning and Building Department. Telephone conversation.





## 7.0 Glossary and Acronyms

### Acronyms

A	Ampere
BPA	Bonneville Power Administration
CWA	Clean Water Act
DLC	Donation Land Claim
EFH	Essential Fish Habitat
EMF	Electric and magnetic fields
EMI	Electromagnetic Interference
EPA	Environmental Protection Agency
ESU	Evolutionarily Significant Unit
FAA	Federal Aviation Administration
FCC	Federal Communication Commission
FEMA	Federal Emergency Management Agency
NAS	National Academy of Sciences
NEPA	National Environmental Policy Act
NESC	National Electrical Safety Code
NIEHS	National Institute of Environmental Health Sciences
NPDES	National Pollutant Discharge Elimination System
NRC	National Research Council
NWI	National Wetland Inventory
ODFW	Oregon Department of Fish and Wildlife
PEM	Palustrine emergent
PGE	Portland General Electric
PFO	Palustrine forested
PSS	Palustrine scrub-shrub
RI	Radio Interference
ROW	Right-of-way

SWPP	Stormwater Pollution Prevention
TVI	Television Interference
USFWS	U.S. Fish and Wildlife Service
USGS	U.S. Geological Service

### **Technical Terms**

Anadromous	Refers to fish such as salmon that hatch and rear in fresh water, move to the ocean to mature, and then return to fresh water to reproduce.
Alluvium	Material such as sand, silt, or clay that has been deposited on land by running water of streams and rivers.
Arcing	The process of current flowing across a gap, such as fault current flowing across an insulator string that flashed over due to a lightening strike.
Biological Assessment	A document required by the Endangered Species Act, which requires an evaluation of potential effects on listed species and critical habitat prior to implementing a proposed action. A proposed action is defined as any activity authorized, funded or carried out by a federal agency.
Blackouts	The disconnection of the source of electricity from all the electrical loads in a certain geographical area. Brought about by an emergency forced outage or other fault in the generation, transmission or distribution system serving the area.
Capacity	A measure of the ability of the transmission line to carry electricity.
Circuit	A system of conductors through which an electric current is intended to flow.
Conductor	Any metallic material, usually in the form of wire, cable, or bar, suitable for carrying an electrical current.
Corona	The phenomenon whereby the electric field associated with a power line cause ionization (molecular breakdown) of surrounding air, thus creating a high-frequency noise. This noise can be heard as static over an automobile radio when travelling under the power line.
Danger tree	Trees that pose a danger or hazard to the transmission line.
Double-circuit line	To place two separate electrical circuits on the same transmission structures or poles. Each circuit contains three separate conductors or bundles of conductors.

Floodplain	That portion of a river valley adjacent to the stream channel which is covered with water when the stream overflows its banks during flood stage.
Lattice steel	Refers to transmission towers constructed of multiple steel members that are connected together (usually in triangular shapes) to make up a frame.
Load	The amount of electric energy delivered or required at any specific point or points on a system. Load originates primarily at the energy using equipment of consumers, such as heaters, air conditioners, lights and motors. At BPA, load includes delivery to direct service industries (Note: Load is slightly larger than metered energy because of normal transmission and distribution losses in delivery from generator to consumer). Because loads are used to determine resource requirements, forecasts of electricity use are converted to loads.
Median	The middle number in a given sequence of numbers.
Mitigation	Steps taken to remove or lessen the effects predicted for each resource, as potentially caused by the transmission project. They may include reducing the impact, compensating for the impact, or avoiding it entirely. Some measures, such as adjusting the location of the towers to avoid a particular resource, are taken during the study and location process. Others, such as reseeding access roads, and/or avoiding the proliferation of weeds, are taken following project completion.
National Electrical Safety Code (NESC)	Written standards for the design, construction, maintenance and operation of electric supply and communication lines, equipment, and supply station in order to safeguard persons from hazards associated with those activities.
National Environmental Policy Act (NEPA)	A 1969 federal law that required evaluation of the environmental impact of federally funded projects and programs.
Noxious weeds	Plants that are injurious to public health, crops, livestock, land, or other property.
Outage	An event, caused by a disturbance on the electrical system, that requires BPA to remove a piece of equipment or a section of line from service. The disturbance can be either natural or caused by humans.
Overload	When too much current flows through transmission facilities that could cause damage or overheating. In the event of overloading, equipment has safeguards to disconnect it from the flow of electricity.

Palustrine emergent wetland	A shallow freshwater wetland characterized by erect, rotted, herbaceous hydrophytes (water loving plants).
Palustrine forested wetland	A wetland characterized by woody vegetation that is 20 feet or more in height.
Palustrine scrub-shrub wetland	A wetland dominated by woody vegetation less than 20 feet tall. This vegetation includes true shrubs, young trees, and trees and shrubs that are small or stunted because of environmental conditions.
Peak load	The maximum electrical load or the maximum average load during a designated interval such as 15 minutes.
Per capita	Per person
Reliability	The measure of the ability of a power system to provide uninterrupted service, even while that system is under stress.
Right-of-way (ROW)	An easement for a certain purpose over the land of another, such as a strip of land, electric transmission line ditch or pipeline. BPA usually acquires easements for its transmission lines, roads and other facilities such as guys and anchors.
Single-circuit	One electrical circuit consisting of three separate conductors or three bundles of conductors.
Substation	A non-generating electrical power station that serves to transform voltages to higher or lower levels, and that serves as a delivery point to individual customers such as utilities or large industrial plants. The BPA system has more than 400 substations.
Tap	A short transmission line that connects a substation to an existing transmission line.
Transmission grid	An interconnected network of transmission lines and associated equipment for the bulk transfer of electric energy between points of supply and demand. The BPA transmission grid includes some 22,500 circuit kilometers (14,00 circuit miles) of lines connecting more than 400 substations in the Pacific Northwest. The main grid consists of 230-kV, 345-kV, and 500-kV transmission lines.
Transmission line	A high-voltage power line used to carry electric power efficiently over long distances.
Voltage	The driving force that cause a current to flow in an electric circuit. Voltage and volt are often used interchangeably.
Wetlands	An area where the soil experiences anaerobic conditions because of inundation of water during part of any given year. Indicators of a wetland include types of plants, soil characteristics and hydrology.



**SANTIAM - BETHEL TRANSMISSION PROJECT**

**APPENDIX A**  
**ELECTRICAL EFFECTS**

June 2001

Prepared by  
**T. Dan Bracken, Inc.**

for  
**Bonneville Power Administration**



## Table of Contents

<b>1.0</b>	<b>Introduction</b> .....	<b>1</b>
<b>2.0</b>	<b>Physical Description</b> .....	<b>3</b>
2.1	Proposed Line.....	3
2.2	Existing Lines.....	3
<b>3.0</b>	<b>Electric Field</b> .....	<b>3</b>
3.1	Basic Concepts.....	3
3.2	Transmission-line Electric Fields.....	4
3.3	Calculated Values of Electric Fields.....	5
3.4	Environmental Electric Fields.....	6
<b>4.0</b>	<b>Magnetic Field</b> .....	<b>7</b>
4.1	Basic Concepts.....	7
4.2	Transmission-line Magnetic Fields.....	8
4.3	Calculated Values for Magnetic Fields.....	9
4.4	Environmental Magnetic Fields.....	9
<b>5.0</b>	<b>Electric and Magnetic Field (EMF) Effects</b> .....	<b>12</b>
5.1	Electric Fields: Short-term Effects.....	12
5.2	Magnetic Field: Short-term Effects.....	15
<b>6.0</b>	<b>Regulations</b> .....	<b>16</b>
<b>7.0</b>	<b>Audible Noise</b> .....	<b>17</b>
7.1	Basic Concepts.....	17
7.2	Transmission-line Audible Noise.....	19
7.3	Predicted Audible Noise Levels.....	19
7.4	Discussion.....	20
7.5	Conclusion.....	20
<b>8.0</b>	<b>Electromagnetic Interference</b> .....	<b>20</b>
8.1	Basic Concepts.....	20
8.2	Radio Interference (RI).....	21
8.3	Predicted RI Levels.....	21
8.4	Television Interference (TVI).....	22
8.5	Predicted TVI Levels.....	22
8.6	Interference with Other Devices.....	22
8.7	Conclusion.....	22
<b>9.0</b>	<b>Other Corona Effects</b> .....	<b>23</b>
<b>10.0</b>	<b>Summary</b> .....	<b>23</b>
	<b>List of References Cited</b> .....	<b>25</b>
	<b>List of Preparers</b> .....	<b>29</b>



## List of Tables

Table 1:	Physical and electrical characteristics of Santiam - Bethel Project corridors.....	31
Table 2:	Possible corridors for Santiam - Bethel Project .....	31
Table 3:	Calculated electric fields for configurations of the proposed Santiam - Bethel/ Santiam-Chemawa 230-kV line operated at maximum voltage .....	32
Table 4	Calculated magnetic fields for configurations of the proposed Santiam – Bethel/ Santiam - Chemawa 230-kV line operated at maximum current .....	33
Table 5	States with transmission-line field limits .....	34
Table 6	Common noise levels .....	35
Table 7	Typical sound attenuation (in decibels) provided by buildings .....	35
Table 8	Predicted foul-weather audible noise (AN) levels at edge of right-of-way (ROW) for proposed Santiam – Bethel/Santiam - Chemawa 230-kV line .....	36
Table 9	Predicted fair-weather radio interference (RI) levels at 100 feet (30.5 m) from the outside conductor of the proposed Santiam – Bethel/Santiam - Chemawa 230-kV line.....	36
Table 10	Predicted maximum foul-weather television interference (TVI) levels predicted at 100 feet (30.5 m) from the outside conductor of the proposed Santiam – Bethel/Santiam - Chemawa 230-kV line.....	37

## List of Figures

Figure 1	Configurations for proposed Santiam – Bethel/ Santiam- Chemawa 230-kV line: a) proposed line with no parallel lines (Configuration I); and b) proposed line with parallel 500-kV line (Configuration II).....	38
Figure 2	Electric-field profiles for configurations of proposed Santiam – Bethel/Santiam - Chemawa 230-kV line: a) proposed line with no parallel line (Configuration I); and b) proposed line with parallel 500-kV line (Configuration II) .....	39
Figure 3	Magnetic-field profiles for selected configurations of the proposed Santiam - Bethel/ Santiam – Chemawa 230-kV line for maximum current conditions: a) proposed line with no parallel line (Configuration I); and b) proposed line with parallel 500-kV line (Configuration II).....	40

# ELECTRICAL EFFECTS FROM THE PROPOSED SANTIAM - BETHEL TRANSMISSION PROJECT

## 1.0 Introduction

The Bonneville Power Administration (BPA) is proposing to build a 16.7-mile (mi.) (26.9-kilometer [km]) 230-kilovolt (kV) transmission line from the Santiam Substation near Stayton, Oregon, to a tap point on the existing PGE 230-kV Bethel line near Salem, Oregon. The proposed Santiam - Bethel Transmission Project would replace 16.7 mi. (26.9 km) of the single-circuit Santiam - Chemawa 230-kV line with a double-circuit 230-kV line. The proposed double-circuit line would consist of the new Santiam - Bethel 230-kV line and the rebuilt Santiam - Chemawa 230-kV line. Configurations along the existing line route include the right-of-way with no parallel lines (15.2 mi. or 24.5 km) and the right-of-way parallel to an existing 500-kV line (1.5 mi. or 2.4 km). The purpose of this report is to describe and quantify the electrical effects of the proposed Santiam - Bethel Transmission Project. These include the following:

- the levels of 60-hertz (Hz; cycles per second) electric and magnetic fields (EMF) at 3.28 feet (ft.) or 1 meter (m) above the ground,
- the effects associated with those fields,
- the levels of audible noise produced by the line, and
- electromagnetic interference associated with the line.

Electrical effects occur near all transmission lines, including those already present along the proposed route for the Santiam - Bethel line. Therefore, the levels of these quantities for the proposed line are computed and compared with those from the existing lines along the route.

The voltage on the conductors of transmission lines generates an electric field in the space between the conductors and the ground. The electric field is calculated or measured in units of volts-per-meter (V/m) or kilovolts-per-meter (kV/m) at a height of 3.28 ft. (1 m) above the ground. The current flowing in the conductors of the transmission line generates a magnetic field in the air and earth near the transmission line; current is expressed in units of amperes (A). The magnetic field is expressed in milligauss (mG), and is usually measured or calculated at a height of 3.28 ft. (1 m) above the ground. The electric field at the surface of the conductors causes the phenomenon of corona. Corona is the electrical breakdown or ionization of air in very strong electric fields, and is the source of audible noise, electromagnetic radiation, and visible light.

To quantify EMF levels along the route, the electric and magnetic fields from the proposed and existing lines were calculated using the BPA Corona and Field Effects Program (USDOE, undated). In this program, the calculation of 60-Hz fields uses standard superposition techniques for vector fields from several line sources: in this case, the line sources are transmission-line conductors. (Vector fields have both magnitude and direction: these must be taken into account when combining fields from different sources.) Important input parameters to the computer program are voltage, current, and geometric configuration of the line. The transmission-line conductors are assumed to be straight, parallel to each other, and located above and parallel to an infinite flat ground plane. Although such conditions do not

occur under real lines because of conductor sag and variable terrain, the validity and limitations of calculations using these assumptions have been well verified by comparisons with measurements. This approach was used to estimate fields for the proposed Santiam - Bethel line, where minimum clearances were assumed to provide worst-case (highest) estimates for the fields.

Electric fields are calculated using an imaging method. Fields from the conductors and their images in the ground plane are superimposed with the proper magnitude and phase to produce the total field at a selected location.

The total magnetic field is calculated from the vector summation of the fields from currents in all the transmission-line conductors. Balanced currents are assumed for each three-phase circuit; the contribution of induced image currents in the conductive earth is not included. Peak currents and power flow direction for the proposed and existing lines were provided by BPA and are based on the projected winter peak power loads in 2006. In the case of corridors with more than one line, calculations were performed for similar (maximum) current conditions on both lines.

Electric and magnetic fields for the proposed line were calculated at the standard height (3.28 ft. or 1 m) above the ground (IEEE, 1987). Calculations were performed out to 300 ft. (91 m) from the centerline of the existing corridor. The validity and limitations of such calculations have been well verified by measurements. Because maximum voltage, maximum current, and minimum conductor height above-ground are used, ***the calculated values given here represent worst-case conditions:*** i.e., the calculated fields are higher than they would be in practice. Such worst-case conditions would seldom occur.

The corona performance of the proposed line was also predicted using the BPA Corona and Field Effects Program (USDOE, undated). Corona performance is calculated using empirical equations that have been developed over several years from the results of measurements on numerous high-voltage lines (Chartier and Stearns, 1981; Chartier, 1983). The validity of this approach for corona-generated audible noise has been demonstrated through comparisons with measurements on other lines all over the United States (IEEE Committee Report, 1982). The accuracy of this method for predicting corona-generated radio and television interference from transmission lines has also been established (Olsen et al., 1992). Important input parameters to the computer program are voltage, current, conductor size, and geometric configuration of the line.

Corona is a highly variable phenomenon that depends on conditions along a length of line. Predictions of the levels of corona effects are reported in statistical terms to account for this variability. Calculations of audible noise and electromagnetic interference levels were made under conditions of an estimated average operating voltage (235 kV for the proposed line) and with the average line height (43 ft. or 13.1 m). Levels of audible noise, radio interference, and television interference are predicted for both fair and foul weather; however, corona is basically a foul-weather phenomenon. Wet conductors can occur during periods of rain, fog, snow, or icing. Along the route of the proposed Santiam - Bethel transmission line, such conditions are expected to occur about 22% of the time during a year, based on hourly records for the Salem airport from 1996 to 1999. Corona activity also increases with altitude. For purposes of evaluating corona effects from the proposed line, an altitude of 500 ft. (152 m) was assumed.

## **2.0 Physical Description**

### **2.1 Proposed Line**

The proposed double-circuit line would consist of two three-phase circuits, the new Santiam - Bethel 230-kV line and the rebuilt Santiam - Chemawa 230-kV line. Both circuits would have maximum phase-to-phase voltages of 242 kV. The average voltage of the lines would be 235 kV. The maximum electrical current on the lines would be 755 and 644 amperes per phase for the Santiam - Bethel and Santiam - Chemawa lines, respectively. The estimated currents are based on the BPA projected normal winter peak load in 2006. The load factor for these loads is 0.60 (average load = peak load x load factor). BPA provided the physical and operating characteristics of the proposed and existing lines.

The physical dimensions and electrical characteristics for the configuration of the proposed line are shown in Figure 1, and summarized in Table 1. Each phase of the proposed and rebuilt 230-kV lines will have a single 1.600-inch (in.) (4.1 centimeter [cm]) diameter steel-reinforced aluminum conductor (ACSR). Voltage and current waves are displaced by 120° in time (one-third of a cycle) on each electrical phase. The horizontal phase spacing between the upper and lower conductor positions of the two circuits would be 24.5 ft. (7.5 m); the horizontal spacing between the middle conductor positions would be 40.5 ft. (12.3 m). The vertical spacing between the conductor positions would be 18 ft. (5.5 m). Minimum conductor-to-ground clearance would be 31 ft. (9.5 m) at a conductor temperature of 122°F (50°C), which represents maximum operating conditions and high ambient air temperatures; clearances above ground would be greater under normal operating temperatures. The average clearance above ground along a span will be approximately 43 ft. (13.1 m); this value was used for corona calculations. At road crossings, the ground clearance would be at least 39 ft. (11.9 m). The 31-ft. (9.5-m) minimum clearance provided by BPA is greater than the minimum distance of the conductors above ground required to meet the National Electric Safety Code (NESC) (IEEE, 1990). The final design of the proposed line could entail larger clearances. The right-of-way width for the proposed line is 125 ft. (38 m).

### **2.2 Existing Lines**

The proposed double-circuit 230-kV line would replace a section of the existing Santiam - Chemawa 230-kV line along the entire route. There are two possible configurations along the existing Santiam - Chemawa line route: either no parallel line or parallel to the existing BPA Marion - Santiam No. 1 and No. 2 double-circuit 500-kV line (Table 2).

BPA provided information on currents for the existing Santiam - Chemawa line and for the Marion - Santiam No.1 500-kV line. The Marion - Santiam No. 2 line is not energized. The physical and electrical characteristics of the corridor configurations that were analyzed are given in Table 1; cross-sections of the corridors are shown in Figure 1.

## **3.0 Electric Field**

### **3.1 Basic Concepts**

An electric field is said to exist in a region of space if an electrical charge, at rest in that space, experiences a force of electrical origin (i.e., electric fields cause free charges to move). Electric field is a vector quantity: that is, it has both magnitude and direction. The direction corresponds to the direction

that a positive charge would move in the field. Sources of electric fields are unbalanced electrical charges (positive or negative) and time-varying magnetic fields. Transmission lines, distribution lines, house wiring, and appliances generate electric fields in their vicinity because of unbalanced electrical charge on energized conductors. The unbalanced charge is associated with the voltage on the energized system. On the power system in North America, the voltage and charge on the energized conductors are cyclic (plus to minus to plus) at a rate of 60 times per second. This changing voltage results in electric fields near sources that are also time-varying at a frequency of 60 hertz (Hz; a frequency unit equivalent to cycles per second).

As noted earlier, electric fields are expressed in units of volts per meter (V/m) or kilovolts (thousands of volts) per meter (kV/m). Electric- and magnetic-field magnitudes in this report are expressed in root-mean-square (rms) units. For sinusoidal waves, the rms amplitude is given as the peak amplitude divided by the square root of two.

The spatial uniformity of an electric field depends on the source of the field and the distance from that source. On the ground, under a transmission line, the electric field is nearly constant in magnitude and direction over distances of several feet (1 meter). However, close to transmission- or distribution-line conductors, the field decreases rapidly with distance from the conductors. Similarly, near small sources such as appliances, the field is not uniform and falls off even more rapidly with distance from the device. If an energized conductor (source) is inside a grounded conducting enclosure, then the electric field outside the enclosure is zero, and the source is said to be shielded.

Electric fields interact with the charges in all matter, including living systems. When a conducting object, such as a vehicle or person, is located in a time-varying electric field near a transmission line, the external electric field exerts forces on the charges in the object, and electric fields and currents are induced in the object. If the object is grounded, then the total current induced in the body (the "short-circuit current") flows to earth. The distribution of the currents within, say, the human body, depends on the electrical conductivities of various parts of the body: for example, muscle and blood have higher conductivity than bone and would therefore experience higher currents.

At the boundary surface between air and the conducting object, the field in the air and perpendicular to the conductor surface is much, much larger than the field in the conductor itself. For example, the average surface field on a human standing in a 10 kV/m field is 27 kV/m; the internal fields in the body are much smaller: approximately 0.008 V/m in the torso and 0.45 V/m in the ankles.

### **3.2 Transmission-line Electric Fields**

The electric field created by a high-voltage transmission line extends from the energized conductors to other conducting objects such as the ground, towers, vegetation, buildings, vehicles, and people. The calculated strength of the electric field at a height of 3.28 ft. (1 m) above an unvegetated, flat earth is frequently used to describe the electric field under straight parallel transmission lines. The most important transmission-line parameters that determine the electric field at a 1-m height are conductor height above ground and line voltage.

Calculations of electric fields from transmission lines are performed with computer programs based on well-known physical principles (cf., Deno and Zaffanella, 1982). The calculated values under these conditions represent an ideal situation. When practical conditions approach this ideal model, measurements and calculations agree. Often, however, conditions are far from ideal because of variable terrain and vegetation. In these cases, fields are calculated for ideal conditions, with the lowest conductor clearances to provide upper bounds on the electric field under the transmission lines. With the

use of more complex models or empirical results, it is also possible to account accurately for variations in conductor height, topography, and changes in line direction. Because the fields from different sources add vectorially, it is possible to compute the fields from several different lines if the electrical and geometrical properties of the lines are known. However, in general, electric fields near transmission lines with vegetation below are highly complex and cannot be calculated. Measured fields in such situations are highly variable.

For evaluation of EMF from transmission lines, the fields must be calculated for a specific line condition. The NESC states the condition for evaluating electric-field-induced short-circuit current for lines with voltage above 98 kV, line-to-ground, as follows: conductors are at a minimum clearance from ground corresponding to a conductor temperature of 120°F (49°C), and at a maximum voltage (IEEE, 1990). BPA has supplied the needed information for calculating electric and magnetic fields from the proposed transmission lines: the maximum operating voltage, the estimated peak current in 2006, and the minimum conductor clearances.

There are standard techniques for measuring transmission-line electric fields (IEEE, 1987). Provided that the conditions at a measurement site closely approximate those of the ideal situation assumed for calculations, measurements of electric fields agree well with the calculated values. If the ideal conditions are not approximated, the measured field can differ substantially from calculated values. Usually the actual electric field at ground level is reduced from the calculated values by various common objects that act as shields.

Maximum or peak field values occur over a small area at midspan, where conductors are closest to the ground. As the location of an electric-field profile approaches a tower, the conductor clearance increases, and the peak field decreases. A grounded tower will reduce the electric field considerably by shielding. For the parallel-line configuration considered here, minimum conductor clearances were assumed to occur along the same lateral profile for both lines. This condition will not necessarily occur in practice, because the towers for the parallel lines may be offset or located at different elevations. The assumption of simultaneous minimum clearance results in peak fields that may be larger than what occurs in practice.

For traditional transmission lines, such as the proposed line, where the right-of-way extends laterally well beyond the conductors, electric fields at the edge of the right-of-way are not as sensitive as the peak field to conductor height. Computed values at the edge of the right-of-way for any line height are fairly representative of what can be expected all along the transmission-line corridor. However, the presence of vegetation on and at the edge of the right-of-way will reduce actual electric-field levels below calculated values.

### **3.3 Calculated Values of Electric Fields**

Table 3 shows the calculated values of electric field at 3.28 ft. (1 m) above ground for the proposed Santiam - Bethel 230-kV transmission-line configurations. The peak value on the right-of-way and the value at the edge of the right-of-way are given for the two proposed corridor configurations and for minimum and average conductor clearances. Figure 2a shows lateral profiles for the electric field from the proposed and existing lines for the minimum conductor heights. Figure 2b shows calculated fields for the proposed and existing lines in the configuration with a parallel 500-kV line.

The calculated peak electric field expected on the right-of-way of the proposed line is 2.5 kV/m when there are no parallel lines. As shown in Figure 2a, the peak values would be present only at locations directly under the line, near mid-span, where the conductors are at the minimum clearance. The

conditions of minimum conductor clearance at maximum current and maximum voltage occur very infrequently. The calculated peak levels are rarely reached under real-life conditions, because the actual line height is generally above the minimum value used in the computer model, because the actual voltage is below the maximum value used in the model, and because vegetation within and near the edge of the right-of-way tends to shield the field at ground level. Maximum electric field under the existing parallel 500-kV is 8.1 kV/m.

The largest values expected at the edge of the right-of-way nearest the proposed line would be 0.4 kV/m. For the parallel configuration, the field at the edge of the right-of-way nearest the 500-kV line would be 0.3 kV/m. The largest electric fields at the edges of the existing rights-of-way are 1.3 and 2.6 kV/m for the 230- and 500-kV lines, respectively.

### **3.4 Environmental Electric Fields**

The electric fields associated with the Santiam - Bethel line can be compared with those found in other environments. Sources of 60-Hz electric (and magnetic) fields exist everywhere electricity is used; levels of these fields in the modern environment vary over a wide range. Electric-field levels associated with the use of electrical energy are orders of magnitude greater than the naturally occurring 60-Hz fields of about 0.0001 V/m, which stem from atmospheric and extraterrestrial sources.

Electric fields in outdoor, publicly accessible places range from less than 1 V/m to 12 kV/m; the large fields exist close to high-voltage transmission lines of 500 kV or higher. In remote areas without electrical service, 60-Hz field levels can be much lower than 1 V/m. Electric fields in home and work environments generally are not spatially uniform like those of transmission lines; therefore, care must be taken when making comparisons between fields from different sources such as appliances and electric lines. In addition, fields from all sources can be strongly modified by the presence of conducting objects. However, it is helpful to know the levels of electric fields generated in domestic and office environments in order to compare commonly experienced field levels with those near transmission lines.

Numerous measurements of residential electric fields have been reported for various parts of the United States, Canada, and Europe. Although there have been no large studies of residential electric fields, sufficient data are available to indicate field levels and characteristics. Measurements of domestic 60-Hz electric fields indicate that levels are highly variable and source-dependent. Electric-field levels are not easily predicted because walls and other objects act as shields, because conducting objects perturb the field, and because homes contain numerous localized sources. Internal sources (wiring, fixtures, and appliances) seem to predominate in producing electric fields inside houses. Average measured electric fields in residences are generally in the range of 5 to 20 V/m. In a large occupational exposure monitoring project that included electric-field measurements at homes, average exposures for all groups away from work were generally less than 10 V/m (Bracken, 1990).

Electric fields from household appliances are localized and decrease rapidly with distance from the source. Local electric fields measured at 1 ft. (0.3 m) from small household appliances are typically in the range of 30 to 60 V/m. Stopps and Janischewskyj (1979) reported electric-field measurements near 20 different appliances; at a 1-ft. (0.3-m) distance, fields ranged from 1 to 150 V/m, with a mean of 33 V/m. In another survey, reported by Deno and Zaffanella (1982), field measurements at a 1-ft. (0.3-m) distance from common domestic and workshop sources were found to range from 3 to 70 V/m. The localized fields from appliances are not uniform, and care should be taken in comparing them with transmission-line fields.

Electric blankets can generate higher localized electric fields. Sheppard and Eisenbud (1977) reported fields of 250 V/m at a distance of approximately 1 ft. (0.3 m). Florig et al. (1987) carried out extensive empirical and theoretical analysis of electric-field exposure from electric blankets and presented results in terms of uniform equivalent fields such as those near transmission lines. Depending on what parameter was chosen to represent intensity of exposure and the grounding status of the subject, the equivalent vertical 60-Hz electric-field exposure ranged from 20 to over 3500 V/m. The largest equivalent field corresponds to the measured field on the chest with the blanket-user grounded. The average field on the chest of an ungrounded blanket-user yields an equivalent vertical field of 960 V/m. As manufacturers have become aware of the controversy surrounding EMF exposures, electric blankets have been redesigned to reduce magnetic fields. However, electric fields from these “low field” blankets are still comparable with those from older designs (Bassen et al., 1991).

Generally, people in occupations not directly related to high-voltage equipment are exposed to electric fields comparable with those of residential exposures. For example, the average electric field measured in 14 commercial and retail locations in rural Wisconsin and Michigan was 4.8 V/m (ITT Research Institute, 1984). Median electric field was about 3.4 V/m. These values are about one-third the values in residences reported in the same study. Power-frequency electric fields near video display terminals (VTDs) are about 10 V/m, similar to those of other appliances (Harvey, 1983). Electric-field levels in public buildings such as shops, offices, and malls appear to be comparable with levels in residences.

In a survey of 1,882 volunteers from utilities, electric-field exposures were measured for 2,082 work days and 657 non-work days (Bracken, 1990). Electric-field exposures for occupations other than those directly related to high-voltage equipment were equivalent to those for non-work exposure.

Thus, except for the relatively few occupations where high-voltage sources are prevalent, electric fields encountered in the workplace are probably similar to those of residential exposures. Even in electric-utility occupations where high field sources are present, exposures to high fields are limited on average to minutes per day.

Electric fields found in publicly accessible areas near high-voltage transmission lines can typically range up to 3 kV/m for 230-kV lines, to 10 kV/m for 500-kV lines, and to 12 kV/m for 765-kV lines. Although these peak levels are considerably higher than the levels found in other public areas, they are present only in limited areas on rights-of-way.

The calculated electric fields for the proposed Santiam - Bethel 230-kV transmission line are consistent with the levels reported for other 230-kV transmission lines in Oregon and elsewhere. The electric fields on and at the edge of the right-of-way from the proposed line will be less than those from the Santiam - Chemawa 230-kV line that would be replaced. Electric fields from the existing 500-kV line will remain the same and be larger than those from the proposed or existing 230-kV lines. The calculated electric fields on the right-of-way of the proposed transmission line would be much higher than levels normally encountered in residences and offices.

## **4.0 Magnetic Field**

### **4.1 Basic Concepts**

Magnetic fields can be characterized by the force they exert on a moving charge or on an electrical current. As with the electric field, the magnetic field is a vector quantity characterized by both magnitude and direction. Electrical currents generate magnetic fields. In the case of transmission lines,



distribution lines, house wiring, and appliances, the 60-Hz electric current flowing in the conductors generates a time-varying, 60-Hz magnetic field in the vicinity of these sources. The strength of a magnetic field is measured in terms of magnetic lines of force per unit area, or magnetic flux density. The term “magnetic field,” as used here, is synonymous with magnetic flux density and is expressed in units of Gauss (G) or milligauss (mG).

The uniformity of a magnetic field depends on the nature and proximity of the source, just as the uniformity of an electric field does. Transmission-line-generated magnetic fields are quite uniform over horizontal and vertical distances of several feet near the ground. However, for small sources such as appliances, the magnetic field decreases rapidly over distances comparable with the size of the device.

The interaction of a time-varying magnetic field with conducting objects results in induced electric field and currents in the object. A changing magnetic field through an area generates a voltage around any conducting loop enclosing the area (Faraday's law). This is the physical basis for the operation of an electrical transformer. For a time-varying sinusoidal magnetic field, the magnitude of the induced voltage around the loop is proportional to the area of the loop, the frequency of the field, and the magnitude of the field. The induced voltage around the loop results in an induced electric field and current flow in the loop material. The induced current that flows in the loop depends on the conductivity of the loop.

## **4.2 Transmission-line Magnetic Fields**

The magnetic field generated by currents on transmission-line conductors extends from the conductors through the air and into the ground. The magnitude of the field at a height of 3.28 ft. (1 m) is frequently used to describe the magnetic field under transmission lines. Because the magnetic field is not affected by non-ferrous materials, the field is not influenced by normal objects on the ground under the line. The direction of the maximum field varies with location. (The electric field, by contrast, is essentially vertical near the ground.) The most important transmission-line parameters that determine the magnetic field at 3.28 ft. (1 m) height are conductor height above ground and magnitude of the currents flowing in the conductors. As distance from the transmission-line conductors increases, the magnetic field decreases.

Calculations of magnetic fields from transmission lines are performed using well-known physical principles (cf., Deno and Zaffanella, 1982). The calculated values usually represent the ideal straight parallel-conductor configuration. For simplicity, a flat earth is usually assumed. Balanced currents (currents of the same magnitude for each phase) are also assumed. This is usually valid for transmission lines, where loads on all three phases are maintained in balance during operation. Induced image currents in the earth are usually ignored for calculations of magnetic field under or near the right-of-way. The resulting error is negligible. Only at distances greater than 300 ft. (91 m) from a line do such contributions become significant (Deno and Zaffanella, 1982). The clearance for magnetic-field calculations for the proposed line was the same as that used for electric-field evaluations.

Standard techniques for measuring magnetic fields near transmission lines are described in ANSI IEEE Standard No. 644-1987 (1987). Measured magnetic fields agree well with calculated values, provided the currents and line heights that go into the calculation correspond to the actual values for the line. To realize such agreement, it is necessary to get accurate current readings during field measurements (because currents on transmission lines can vary considerably over short periods of time) and also to account for all field sources in the vicinity of the measurements.

As with electric fields, the maximum or peak magnetic fields occur in areas near the centerline and at midspan where the conductors are the lowest. The magnetic field at the edge of the right-of-way is not very dependent on line height. If more than one line is present, the peak field will depend on the relative electrical phasing of the conductors and the direction of power flow. Phasing information was available for the parallel 500-kV line. Phasing of the proposed line was selected to minimize magnetic field at the edge of the right-of-way.

### **4.3 Calculated Values for Magnetic Fields**

Table 4 gives the calculated values of the magnetic field at 3.28 ft. (1 m) height for the proposed 230-kV transmission-line corridor. Field values on the right-of-way and at the edge of the right-of-way are given for projected maximum currents during winter peak load in 2006, for minimum and average conductor clearances. The maximum currents are 755 A on each of the three phases of the proposed Santiam - Bethel 230-kV line and 644 A on the rebuilt Santiam - Chemawa 230-kV line. Figure 3 shows lateral profiles of maximum magnetic field under this current condition for the two possible corridors of the proposed 230-kV transmission line. The actual magnetic-field levels would vary, as currents on the lines change daily and seasonally and as ambient temperature changes. Average currents over the year would be about 60% of the maximum values. The levels shown in the figures represent the highest magnetic fields expected for the proposed Santiam - Bethel/Santiam - Chemawa 230-kV line. Average fields over a year would be considerably reduced from the peak values, as a result of increased clearances above the minimum value and reduced currents from the maximum value.

The maximum calculated 60-Hz magnetic field expected at 3.28 ft. (1 m) above ground for the proposed line is 87 mG for the proposed line alone and 94 mG when the line parallels the 500-kV line. This field is calculated for the maximum current of 755 A, with the conductors at a height of 31 ft. (9.5 m). The maximum field would decrease for increased conductor clearance. For an average conductor height over a span of 43 ft. (13.1 m), the maximum field would be 50 mG and 58 mG for the proposed line alone and parallel to the 500-kV line, respectively.

At the edge of the right-of-way of the proposed line, the calculated magnetic field for maximum current load conditions is 26 mG. When the line is located parallel to the existing 500-kV line, the field at the edge of the right-of-way adjacent to the proposed line would be 29 mG.

The magnetic field falls off rapidly as distance from the line increases. At a distance of 200 ft. (61 m) from the centerline of the proposed line, the field would be 4 mG for maximum current conditions. The calculated magnetic field for maximum current would be less than 10 mG at about 120 ft. (37 m) from the centerline.

The calculated fields for the two corridors with existing transmission lines are given in Table 4. For the existing lines, the peak magnetic fields on the rights-of-way are 218 mG and 108 mG, for the 230- and 500-kV lines, respectively. Fields at the edges of the existing rights-of-way are 78 mG and 50 mG for the 230- and 500-kV lines, respectively. Addition of the proposed line will not significantly change the magnetic fields under, or at the edge of, the right-of-way of the existing 500-kV line.

### **4.4 Environmental Magnetic Fields**

Transmission lines are not the only source of magnetic fields; as with 60-Hz electric fields, 60-Hz magnetic fields are present throughout the environment of a society that relies on electricity as a principal energy source. The magnetic fields associated with the proposed Santiam - Bethel 230-kV line can be compared with fields from other sources. The range of 60-Hz magnetic-field exposures in publicly

accessible locations such as open spaces, transmission-line rights-of-way, streets, pedestrian walkways, parks, shopping malls, parking lots, shops, hotels, public transportation, and so on range from less than 0.1 mG to about 1 G, with the highest values occurring near small appliances with electric motors. In occupational settings in electric utilities, where high currents are present, magnetic-field exposures for workers can be above 1 G. At 60 Hz, the magnitude of the natural magnetic field is approximately 0.0005 mG.

Several investigations of residential fields have been conducted. In a large study to identify and quantify significant sources of 60-Hz magnetic fields in residences, measurements were made in 996 houses, randomly selected throughout the country (Zaffanella, 1993). The most common sources of residential fields were power lines, the grounding system of residences, and appliances. Field levels were characterized by both point-in-time (spot) measurements and 24-hour measurements. Spot measurements averaged over all rooms in a house exceeded 0.6 mG in 50% of the houses and 2.9 mG in 5% of houses. Power lines generally produced the largest average fields in a house over a 24-hour period. On the other hand, grounding system currents proved to be a more significant source of the highest fields in a house. Appliances were found to produce the highest local fields; however, fields fell off rapidly with increased distance. For example, the median field near microwave ovens was 36.9 mG at a distance of 10.5 in. (0.27 m) and 2.1 mG at 46 in. (1.17 m). Across the entire sample of 996 houses, higher magnetic fields were found in, among others, urban areas (vs. rural); multi-unit dwellings (vs. single-family); old houses (vs. new); and houses with grounding to a municipal water system.

In an extensive measurement project to characterize the magnetic-field exposure of the general population, over 1000 randomly selected persons in the United States wore a personal exposure meter for 24 hours and recorded their location in a simple diary (Zaffanella and Kalton, 1998). Based on the measurements of 853 persons, the estimated 24-hour average exposure for the general population is 1.24 mG and the estimated median exposure is 0.88 mG. The average field "at home, not in bed" is 1.27 mG and "at home, in bed" is 1.11 mG. Average personal exposures were found to be largest "at work" (mean of 1.79 mG and median of 1.01 mG) and lowest "at home, in bed" (mean of 1.11 mG and median of 0.49 mG). Average fields in school were also low (mean of 0.88 mG and median of 0.69 mG). Factors associated with higher exposures at home were smaller residences, duplexes and apartments, metallic rather than plastic water pipes, and nearby overhead distribution lines.

As noted above, magnetic fields from appliances are localized and decrease rapidly with distance from the source. Localized 60-Hz magnetic fields have been measured near about 100 household appliances such as ranges, refrigerators, electric drills, food mixers, and shavers (Gauger, 1985). At a distance of 1 ft. (0.3 m), the maximum magnetic field ranged from 0.3 to 270 mG, with 95% of the measurements below 100 mG. Ninety-five percent of the levels at a distance of 4.9 ft. (1.5 m) were less than 1 mG. Devices that use light-weight, high-torque motors with little magnetic shielding exhibited the largest fields. These included vacuum cleaners and small hand-held appliances and tools. Microwave ovens with large power transformers also exhibited relatively large fields. Electric blankets have been a much-studied source of magnetic-field exposure because of the length of time they are used and because of the close proximity to the body. Florig and Hoburg (1988) estimated that the average magnetic field in a person using an electric blanket was 15 mG, and that the maximum field could be 100 mG. New "low-field" blankets have magnetic fields at least 10 times lower than those from conventional blankets (Bassen et al., 1991).

In a domestic magnetic-field survey, Silva et al. (1989) measured fields near different appliances at locations typifying normal use (e.g., sitting at a typewriter or standing at a stove). Specific appliances with relatively large fields included can openers (n = 9), with typical fields ranging from 30 to 225 mG and a maximum value up to 2.7 G; shavers (n = 4), with typical fields from 50 to 300 mG and maximum

fields up to 6.9 G; and electric drills ( $n = 2$ ), with typical fields from 56 to 190 mG and maximum fields up to 1.5 G. The fields from such appliances fall off very rapidly with distance and are only present for short periods. Thus, although instantaneous magnetic-field levels close to small hand-held appliances can be quite large, they do not contribute to average area levels in residences.

Although studies of residential magnetic fields have not all considered the same independent parameters, the following consistent characterization of residential magnetic fields emerges from the data:

- (1) External sources play a large role in determining residential magnetic-field levels. Transmission lines, when nearby, are an important external source. Unbalanced ground currents on neutral conductors and other conductors, such as water pipes in and near a house, can represent a significant source of magnetic field. Distribution lines per se, unless they are quite close to a residence, do not appear to be a traditional distance-dependent source.
- (2) Homes with overhead electrical service appear to have higher average fields than those with underground service.
- (3) Appliances represent a localized source of magnetic fields that can be much higher than average or area fields. However, fields from appliances approach area levels at distances greater than 3 ft. (1 m) from the device.

Although important variables in determining residential magnetic fields have been identified, quantification and modeling of their influence on fields at specific locations is not yet possible. However, a general characterization of residential magnetic-field level is possible: average levels in the United States are in the range of 0.5 to 1.0 mG, with the average field in a small number of homes exceeding this range by as much as a factor of 10 or more. Average personal exposure levels are slightly higher, possibly due to use of appliances and varying distances to other sources. Maximum fields can be much higher.

Magnetic fields in commercial and retail locations are comparable with those in residences. As with appliances, certain equipment or machines can be a local source of higher magnetic fields. Utility workers who work close to transformers, generators, cables, transmission lines, and distribution systems clearly experience high-level fields. Other sources of fields in the workplace include motors, welding machines, computers, and video display terminals (VDTs). In publicly accessible indoor areas, such as offices and stores, field levels are generally comparable with residential levels, unless a high-current source is nearby.

Because high-current sources of magnetic field are more prevalent than high-voltage sources, occupational environments with relatively high magnetic fields encompass a more diverse set of occupations than do those with high electric fields. For example, in occupational magnetic-field measurements reported by Bowman et al. (1988), the geometric mean field from 105 measurements of magnetic field in "electrical worker" job locations was 5.0 mG. "Electrical worker" environments showed the following elevated magnetic-field levels (geometric mean greater than 20 mG): industrial power supplies, alternating current (ac) welding machines, and sputtering systems for electronic assembly. For secretaries in the same study, the geometric mean field was 3.1 mG for those using VDTs ( $n = 6$ ) and 1.1 mG for those not using VDTs ( $n = 3$ ).

Measurements of personal exposure to magnetic fields were made for 1,882 volunteer utility workers for a total of 4,411 workdays (Bracken, 1990). Median workday mean exposures ranged from 0.5 mG for clerical workers without computers to 7.2 mG for substation operators. Occupations not specifically associated with transmission and distribution facilities had median workday exposures less than 1.5 mG,

while those associated with such facilities had median exposures above 2.3 mG. Magnetic-field exposures measured in homes during this study were comparable with those recorded in offices.

Magnetic fields in publicly accessible outdoor areas seem to be, as expected, directly related to proximity to electric-power transmission and distribution facilities. Near such facilities, magnetic fields are generally higher than indoors (residential). Higher-voltage facilities tend to have higher fields. Typical maximum magnetic fields in publicly accessible areas near transmission facilities can range from less than a few milligauss up to 300 mG or more, near heavily loaded lines operated at 230 to 765 kV. The levels depend on the line load, conductor height, and location on the right-of-way. Because magnetic fields near high-voltage transmission lines depend on the current in the line, they can vary daily and seasonally. To characterize fields from the distribution system, Heroux (1987) measured 60-Hz magnetic fields with a mobile platform along 140 mi. (223 km) of roads in Montreal. The median field level averaged over nine different routes was 1.6 mG, with 90% of the measurements less than about 5.1 mG. Spot measurements indicated that typical fields directly above underground distribution systems were 5 to 19 mG. Beneath overhead distribution lines, typical fields were 1.5 to 5 mG on the primary side of the transformer, and 4 to 10 mG on the secondary side. Near ground-based transformers used in residential areas, fields were 80 to 1000 mG at the surface and 10 to 100 mG at a distance of 1 ft. (0.3 m).

The magnetic fields from the proposed 230-kV transmission line would be less than those from the existing 230-kV line that is being replaced. The fields from the proposed line would be comparable to or less than those from existing 230-kV lines in Oregon and elsewhere. On and near the right-of-way of the proposed line, magnetic fields would be well above average residential levels. However, the fields from the line would decrease rapidly and approach common ambient levels at distances greater than a few hundred feet from the line. Furthermore, the fields at the edge of the right-of-way would not be above those encountered during normal activities near common sources such as hand-held appliances.

## **5.0 Electric and Magnetic Field (EMF) Effects**

Possible effects associated with the interaction of EMF from transmission lines with people on and near a right-of-way fall into two categories: short-term effects that can be perceived and may represent a nuisance, and possible long-term health effects. Only short-term effects are discussed here. The issue of whether there are long-term health effects associated with transmission-line fields is controversial. In recent years, considerable research on possible biological effects of EMF has been conducted. A review of these studies and their implications for health-related effects is provided in a separate technical report for the environmental assessment for the proposed Santiam - Bethel 230-kV transmission line.

### **5.1 Electric Fields: Short-term Effects**

Short-term effects from transmission-line electric fields are associated with perception of induced currents and voltages or perception of the field. Induced current or spark discharge shocks can be experienced under certain conditions when a person contacts objects in an electric field. Such effects occur in the fields associated with transmission lines that have voltages of 230-kV or higher. These effects could occur infrequently under the proposed Santiam - Bethel 230-kV line. The higher electric fields under the existing 500-kV Marion-Santiam line are much more likely to result in such effects.

Steady-state currents are those that flow continuously after a person contacts an object and provides a path to ground for the induced current. The amplitude of the steady-state current depends on the induced current to the object in question and on the grounding path. The magnitude of the induced current to vehicles and objects under the proposed line will depend on the electric-field strength and the size and

shape of the object. When an object is electrically grounded, the voltage on the object is reduced to zero, and it is not a source of current or voltage shocks. If the object is poorly grounded or not grounded at all, then it acquires some voltage relative to earth and is a possible source of current or voltage shocks.

The responses of persons to steady-state current shocks have been extensively studied, and levels of response documented (Keesey and Letcher, 1969; IEEE, 1978). Primary shocks are those that can result in direct physiological harm. Such shocks will not be possible from induced currents under the existing or proposed lines, because clearances above ground required by the NESC preclude such shocks from large vehicles and grounding practices eliminate large stationary objects as sources of such shocks.

Secondary shocks are defined as those that could cause an involuntary and potentially harmful movement, but no direct physiological harm. Secondary shocks could occur under the proposed 230-kV line when making contact with ungrounded conducting objects such as vehicles or equipment. However, such occurrences are anticipated to be very infrequent. Shocks, when they occur under the 230-kV line, are most likely to be below the nuisance level. Induced currents are extremely unlikely to be perceived off the right-of-way of the proposed line.

Induced currents are always present in electric fields under transmission lines and will be present near the proposed line. However, during initial construction, BPA routinely grounds metal objects that are located on or near the right-of-way. The grounding eliminates these objects as sources of induced current and voltage shocks. Multiple grounding points are used to provide redundant paths for induced current flow. After construction, BPA would respond to any complaints and install or repair grounding to mitigate nuisance shocks.

Unlike fences or buildings, mobile objects such as vehicles and farm machinery cannot be grounded permanently. Limiting the possibility of induced currents from such objects to persons is accomplished in several ways. First, required clearances for above-ground conductors tend to limit field strengths to levels that do not represent a hazard or nuisance. The NESC (IEEE, 1990) requires that, for lines with voltage exceeding 98 kV line-to-ground (170 kV line-to-line), sufficient conductor clearance be maintained to limit the induced short-circuit current in the largest anticipated vehicle under the line to 5 milliamperes (mA) or less. This can be accomplished by limiting access or by increasing conductor clearances in areas where large vehicles could be present. BPA and other utilities design and operate lines to be in compliance with the NESC.

For the proposed line, conductor clearances (50°C conductor temperature) would be increased to at least 39 ft. (11.9 m) over road crossings along the route, resulting in a maximum field of 1.7 kV/m or less at the 3.28 ft. (1 m) height. The largest truck allowed on roads in Oregon without a special permit is 14 feet high by 8.5 feet wide by 75 feet long (4.3 x 2.6 x 22.9 m). The induced currents to such a vehicle oriented perpendicular to the line in a maximum field of 1.7 kV/m (at 3.28-foot height) would be less than 1.5 mA (Reilly, 1979). For smaller trucks, the maximum induced currents for perpendicular orientation to the proposed line would be less than this value. (Larger special-permitted trucks, such as triple trailers, can be up to 105 feet in length. However, because they average the field over such a long distance, the maximum induced current to a 105-foot vehicle oriented perpendicular to the 230-kV line at a road crossing would be less than 1.4 mA.) Thus, the NESC 5-mA criterion would be met for perpendicular road crossings of the proposed line. These large vehicles are not anticipated to be off highways or oriented parallel to the proposed line. Even if they were, the NESC 5-mA criterion would be met under the proposed line. As discussed below, these are worst-case estimates of induced currents at road crossings; conditions for their occurrence are rare. The conductor clearance at each road crossing would be checked during the design stage of the line to ensure that the NESC 5-mA criterion is met. Furthermore, it is BPA policy to limit the maximum induced current from vehicles to 2 mA in

commercial parking lots. Line clearances would also be increased in accordance with the NESC, such as over railroads and water areas suitable for sailboating.

Several factors tend to reduce the levels of induced current shocks from vehicles:

- (1) Activities are distributed over the whole right-of-way, and only a small percentage of time is spent in areas where the field is at or close to the maximum value.
- (2) At road crossings, vehicles are aligned perpendicular to the conductors, resulting in a substantial reduction in induced current.
- (3) The conductor clearance at road crossings may not be at minimum values because of lower conductor temperatures and/or location of the road crossing away from midspan.
- (4) The largest vehicles are permitted only on certain highways.
- (5) Off-road vehicles are in contact with soil or vegetation, which reduces shock currents substantially.

Induced voltages occur on objects, such as vehicles, in an electric field where there is an inadequate electrical ground. If the voltage is sufficiently high, then a spark discharge shock can occur as contact is made with the object. Such shocks are similar to "carpet" shocks that occur, for example, when a person touches a doorknob after walking across a carpet on a dry day.

In electric fields higher than will occur under the proposed line, it is theoretically possible for a spark discharge from the induced voltage on a large vehicle to ignite gasoline vapor during refueling. The probability for exactly the right conditions to occur for ignition is extremely remote. The additional clearance of conductors provided at road crossings reduces the electric field in areas where vehicles are prevalent and reduces the chances for such events. Even so, BPA recommends that vehicles should not be refueled under the proposed line unless specific precautions are taken to ground the vehicle and the fueling source (USDOE, 1995).

Under certain conditions, the electric field can be perceived through hair movement on an upraised hand or arm of a person standing on the ground under high-voltage transmission lines. The median field for perception in this manner was 7 kV/m for 136 persons; only about 12% could perceive fields of 2 kV/m or less (Deno and Zaffanella, 1982). Even in areas under the conductors at midspan, the fields at ground level would be below the levels where field perception normally occurs. Therefore, it is unlikely that the field would be perceived anywhere on the right-of-way. Where vegetation provides shielding, the field would not be perceived.

Conductive shielding reduces both the electric field and induced effects such as shocks. Persons inside a vehicle cab or canopy are shielded from the electric field. Similarly, a row of trees or a lower-voltage distribution line reduces the field on the ground in the vicinity. Metal pipes, wiring, and other conductors in a residence or building shield the interior from the transmission-line electric field.

Thus, potential impacts of electric fields can be mitigated through grounding policies, adherence to the NESC, and increased clearances above the minimums specified by the NESC. Worst-case levels are used for safety analyses but, in practice, induced currents and voltages are reduced considerably by unintentional grounding. Shielding by conducting objects, such as vehicles and vegetation, also reduces the potential for electric-field effects.

The electric fields from the proposed 230-kV line will be less than those from the line it is replacing. Therefore the potential for impacts of electric fields will be reduced from that now present on the existing right-of-way. The potential for effects from the parallel 500-kV line will remain the same.

## **5.2 Magnetic Field: Short-term Effects**

Magnetic fields associated with transmission and distribution systems can induce voltage and current in long conducting objects that are parallel to the transmission line. As with electric-field induction, these induced voltages and currents are a potential source of shocks. A fence, irrigation pipe, pipeline, electrical distribution line, or telephone line forms a conducting loop when it is grounded at both ends. The earth forms the other portion of the loop. The magnetic field from a transmission line can induce a current to flow in such a loop if it is oriented parallel to the line. If only one end of the fence is grounded, then an induced voltage appears across the open end of the loop. The possibility for a shock exists if a person closes the loop at the open end by contacting both the ground and the conductor. The magnitude of this potential shock depends on the following factors: the magnitude of the field; the length of the object (the longer the object, the larger the induced voltage); the orientation of the object with respect to the transmission line (parallel as opposed to perpendicular, where no induction would occur); and the amount of electrical resistance in the loop (high resistance limits the current flow).

Magnetically induced currents from power lines have been investigated for many years; calculation methods and mitigating measures are available. A comprehensive study of gas pipelines near transmission lines developed prediction methods and mitigation techniques specifically for induced voltages on pipelines (Dabkowski and Taflove, 1979; Taflove and Dabkowski, 1979). Similar techniques and procedures are available for irrigation pipes and fences. Grounding policies employed by utilities for long fences reduce the potential magnitude of induced voltage.

The magnitude of the coupling with both pipes and fences is very dependent on the electrical unbalance (unequal currents) among the three phases of the line. Thus, a distribution line where a phase outage may go unnoticed for long periods of time can represent a larger source of induced currents than a transmission line where the loads are well-balanced (Jaffa and Stewart, 1981).

Knowledge of the phenomenon, grounding practices, and the availability of mitigation measures mean that magnetic-induction effects from the proposed 230-kV transmission line will be minimal.

Magnetic fields from transmission and distribution facilities can interfere with certain electronic equipment. Magnetic fields can cause distortion of the image on VDTs and computer monitors. The threshold field for interference depends on the type and size of monitor and the frequency of the field. Interference has been observed for certain monitors at fields at or below 10 mG (Baishiki et al., 1990; Banfai et al., 2000). Generally, the problem arises when computer monitors are in use near electrical distribution facilities in large office buildings. Fields from the proposed line would fall below this level at approximately 120 ft. (37 m) from the centerline.

Interference from magnetic fields can be eliminated by shielding the affected monitor or moving it to an area with lower fields. Similar mitigation methods could be applied to other sensitive electronics, if necessary. Interference from 60-Hz fields with computers and control circuits in vehicles and other equipment is not anticipated at the field levels found under and near the proposed 230-kV transmission line.



The magnetic fields from the proposed line will be less than those from the existing line that is being replaced. Therefore the potential for impacts from magnetic fields will be reduced from that on the existing right-of-way. The potential for effects from the parallel 500-kV line will remain the same.

## **6.0 Regulations**

Regulations that apply to transmission-line electric and magnetic fields fall into two categories. Safety standards or codes are intended to limit or eliminate electric shocks that could seriously injure or kill persons. Field limits or guidelines are intended to limit electric- and magnetic-field exposures that can cause nuisance shocks or might cause health effects. In no case has a limit or standard been established because of a known or demonstrated health effect.

The proposed line would be designed to meet the NESC (IEEE, 1990), which specifies how far transmission-line conductors must be from the ground and other objects. The clearances specified in the code provide safe distances that prevent harmful shocks to workers and the public. In addition, people who live and work near transmission lines must be aware of safety precautions to avoid electrical (which is not necessarily physical) contact with the conductors. For example, farmers should not up-end irrigation pipes under a transmission or other electrical line. In addition, as a matter of safety, the NESC specifies that electric-field-induced currents from transmission lines must be below the 5 mA (“let go”) threshold deemed a lower limit for primary shock. BPA publishes and distributes a brochure that describes safe practices to protect against shock hazards around power lines (USDOE, 1995).

Field limits or guidelines have been adopted in several states and countries and by national and international organizations. Electric-field limits have generally been based on minimizing nuisance shocks or field perception. The intent of magnetic-field limits has been to limit exposures to existing levels, given the uncertainty of their potential for health effects.

There are currently no national standards in the United States for 60-Hz electric and magnetic fields. Several states have been active in establishing mandatory or suggested limits on 60-Hz electric and (in two cases) magnetic fields. Six states have specific electric-field limits that apply to transmission lines: Florida, Minnesota, Montana, New Jersey, New York, and Oregon. Florida and New York have established regulations for magnetic fields. These regulations are summarized in Table 5, adapted from TDHS Report (1989).

Electric-field limits for the states have been given in terms of maximum field or edge-of-right-of-way field, or both. The Oregon limit of 9 kV/m for electric fields is applied to areas accessible to the public (Oregon, 1980). The Oregon rule, which is found in transmission-line siting procedures also addresses grounding practices, audible noise, and radio interference.

Government agencies and utilities operating transmission systems have established design criteria that include EMF levels. BPA has maximum allowable electric fields of 9 and 5 kV/m on and at the edge of the right-of-way, respectively (USDOE, 1996). BPA also has maximum-allowable electric field strengths of 5 kV/m, 3.5 kV/m, and 2.5 kV/m for road crossings, shopping center parking lots, and commercial/industrial parking lots, respectively. These levels are based on limiting the maximum short-circuit currents from anticipated vehicles to less than 1 mA in shopping center lots and to less than 2 mA in commercial parking lots.

Electric-field limits for overhead power lines have also been established in other countries (Maddock, 1992). Limits for magnetic fields from overhead power lines have not been explicitly established

anywhere except in Florida and New York. However, general guidelines and limits on EMF have been established for occupational and public exposure in several countries and by national and international organizations.

The American Conference of Governmental Industrial Hygienists (ACGIH) sets guidelines (Threshold Limit Values or TLV) for occupational exposures to environmental agents (ACGIH, 2000). In general, a TLV represents the level below which it is believed that nearly all workers may be exposed repeatedly without adverse health effects. For EMF, the TLVs represent ceiling levels. For 60-Hz electric fields, occupational exposures should not exceed the TLV of 25 kV/m. However, the ACGIH also recognizes the potential for startle reactions from spark discharges and short-circuit currents in fields greater than 5-7 kV/m, and recommends implementing grounding practices. They recommend the use of conductive clothing for work in fields exceeding 15 kV/m. The TLV for occupational exposure to 60-Hz magnetic fields is a ceiling level of 10 G (10,000 mG) (ACGIH, 2000).

Electric and magnetic fields from various sources (including automobile ignitions, appliances, and, possibly, transmission lines) can interfere with implanted cardiac pacemakers. In light of this potential problem, manufacturers design devices to be immune from such interference. However, research has shown that these efforts have not been completely successful and that a few models of pacemakers could be affected by 60-Hz fields from transmission lines. There were also numerous models of pacemakers that were not affected by fields even larger than those found under transmission lines. Because of the known potential for interference with pacemakers by 60-Hz fields, field limits for pacemaker wearers have been established by the ACGIH. They recommend that wearers of pacemakers and similar medical-assist devices limit their exposure to electric fields of 1 kV/m or less and to magnetic fields to 1 G (1,000 mG) or less (ACGIH, 2000).

The International Committee on Non-ionizing Radiation Protection (ICNIRP), working in cooperation with the World Health Organization (WHO) has developed guidelines for occupational and public exposures to EMF (ICNIRP, 1998). For occupational exposures at 60 Hz, the recommended limits to exposure are 8.3 kV/m for electric fields and 4.2 G (4,200 mG) for magnetic fields. The electric-field level can be exceeded, provided precautions are taken to prevent spark discharge and induced current shocks. For the general public, the ICNIRP guidelines recommend exposure limits of 4.2 kV/m for electric fields and 0.83 G (830 mG) for magnetic fields (ICNIRP, 1998).

ICNIRP has also established guidelines for contact currents, which could occur when a grounded person contacts an ungrounded object in an electric field. The guideline levels are 1.0 mA for occupational exposure and 0.5 mA for public exposure.

The estimated peak electric field and magnetic field on, and at the edge of, the right-of-way of the proposed transmission line would meet limits set in all states, including Oregon. The electric fields from the proposed 230-kV line would meet the ACGIH standards, provided wearers of pacemakers and similar medical-assist devices are discouraged from unshielded right-of-way use. (A passenger in an automobile under the line would be shielded from the electric field.) The electric fields from the proposed line would meet the ICNIRP guideline for public exposure. The magnetic fields from the proposed line would be below the ACGIH and IRPA/INIRC limits. The electric fields present on the right-of-way could induce currents in ungrounded vehicles that exceeded the ICNIRP level of 0.5 mA.

## **7.0 Audible Noise**

### **7.1 Basic Concepts**

Audible noise (AN), as defined here, represents an unwanted sound, as from a transmission line, transformer, airport, or vehicle traffic. Sound is a pressure wave caused by a sound source vibrating or displacing air. The ear converts the pressure fluctuations into auditory sensations. AN from a source is superimposed on the background or ambient noise that is present before the source is introduced.

The amplitude of a sound wave is the incremental pressure resulting from sound above atmospheric pressure. The sound-pressure level is the fundamental measure of AN; it is generally measured on a logarithmic scale with respect to a reference pressure. The sound-pressure level (SPL) in decibels (dB) is given by:

$$\text{SPL} = 20 \log (P/P_0)\text{dB}$$

where P is the effective rms (root-mean-square) sound pressure,  $P_0$  is the reference pressure, and the logarithm (log) is to the base 10. The reference pressure for measurements concerned with hearing is usually taken as 20 micropascals (Pa), which is the approximate threshold of hearing for the human ear. A logarithmic scale is used to encompass the wide range of sound levels present in the environment. The range of human hearing is from 0 dB up to about 140 dB, a ratio of 10 million in pressure (EPA, 1978).

Logarithmic scales, such as the decibel scale, are not directly additive: to combine decibel levels, the dB values must be converted back to their respective equivalent pressure values, the total rms pressure level found, and the dB value of the total recalculated. For example, adding two sounds of equal level on the dB scale results in a 3 dB increase in sound level. Such an increase in sound pressure level of 3 dB, which corresponds to a doubling of the energy in the sound wave, is barely discernible by the human ear. It requires an increase of about 10 dB in SPL to produce a subjective doubling of sound level for humans. The upper range of hearing for humans (140 dB) corresponds to a sharply painful response (EPA, 1978).

Humans respond to sounds in the frequency range of 16 to 20,000 Hz. The human response depends on frequency, with the most sensitive range roughly between 2000 and 4000 Hz. The frequency-dependent sensitivity is reflected in various weighting scales for measuring audible noise. The A-weighted scale weights the various frequency components of a noise in approximately the same way that the human ear responds. This scale is generally used to measure and describe levels of environmental sounds such as those from vehicles or occupational sources. The A-weighted scale is also used to characterize transmission-line noise. Sound levels measured on the A-scale are expressed in units of dB(A) or dBA.

AN levels and, in particular, corona-generated audible noise (see below) vary in time. In order to account for fluctuating sound levels, statistical descriptors have been developed for environmental noise. Exceedence levels (L levels) refer to the A-weighted sound level that is exceeded for a specified percentage of the time. Thus, the  $L_5$  level refers to the noise level that is exceeded only 5% of the time.  $L_{50}$  refers to the sound level exceeded 50% of the time. Sound-level measurements and predictions for transmission lines are often expressed in terms of exceedence levels, with the  $L_5$  level representing the maximum level and the  $L_{50}$  level representing a median level.

Table 6 shows AN levels from various common sources. Clearly, there is wide variation. Noise exposure depends on how much time an individual spends in different locations. Outdoor noise generally does not contribute to indoor levels (EPA, 1974). Activities in a building or residence generally dominate interior AN levels. The amount of sound attenuation (reduction) provided by buildings is given in Table 7. Assuming that residences along the line route fall in the "warm climate, windows open" category, the typical sound attenuation provided by a house is about 12 dBA.

The BPA design criterion for corona-generated audible noise ( $L_{50}$ , foul weather) is  $50 \pm 2$  dBA at the edge of the ROW. This criterion has been interpreted by the state and BPA to meet Oregon Noise Control Regulations (Perry, 1982). The Environmental Protection Agency (EPA) has established a guideline of 55 dBA for the annual average day-night level ( $L_{dn}$ ) in outdoor areas (EPA, 1978). In computing this value, a 10 dB correction (penalty) is added to night-time noise between the hours of 10 p.m. and 7 a.m.

## 7.2 Transmission-line Audible Noise

Corona is the partial electrical breakdown of the insulating properties of air around the conductors of a transmission line. In a small volume near the surface of the conductors, energy and heat are dissipated. Part of this energy is in the form of small local pressure changes that result in audible noise. Corona-generated audible noise can be characterized as a hissing, crackling sound that, under certain conditions, is accompanied by a 120-Hz hum.

Corona-generated audible noise is of concern primarily for contemporary lines operating at voltages of 345 kV and higher during foul weather. Thus in the area where the proposed 230-kV line parallels a 500-kV line, audible noise from the higher voltage line will predominate. In other areas, the proposed 230-kV line will produce some noise under foul-weather conditions.

The conductors of high-voltage transmission lines are designed to be corona-free under ideal conditions. However, protrusions on the conductor surface—particularly water droplets on or dripping off the conductors—cause electric fields near the conductor surface to exceed corona onset levels, and corona occurs. Therefore, audible noise from transmission lines is generally a foul-weather (wet-conductor) phenomenon. Wet conductors can occur during periods of rain, fog, snow, or icing. Based on meteorologic records near the route of the proposed transmission line, such conditions are expected to occur less than 22% of the time during the year. For a few months after line construction, residual grease or oil on the conductors can cause water to bead up on the surface. This results in more corona sources and slightly higher levels of audible noise and electromagnetic interference if the line is energized. However, the new conductors "age" in a few months, and the level of corona activity decreases to the predicted equilibrium value. During fair weather, insects and dust on the conductor can also serve as sources of corona. The proposed line has been designed with 1.600-in. (4.1-cm) diameter conductors that will yield acceptable corona levels.

## 7.3 Predicted Audible Noise Levels

The predicted levels of corona-generated audible noise for the proposed line operated at a voltage of 235 kV are given in Table 8. For comparison, Table 8 also gives the calculated levels for the existing lines. Audible noise levels are calculated for average voltage and average conductor heights for fair- and foul-weather conditions. The calculated median level ( $L_{50}$ ) during foul weather at the edge of the proposed Santiam - Bethel right-of-way is about 39 dBA, which is less than that from the existing Santiam - Chemawa 230-kV line. Where the proposed Santiam - Bethel line parallels the Marion - Santiam 500-kV line, noise from the higher-voltage line will predominate and there would be no change in noise levels from existing conditions. For this configuration, the noise at the edge of the right-of-way near the proposed line would be 47 dBA.

During fair-weather conditions, which occur about 78% of the time, audible noise levels at the edge of the right-of-way would be about 20 dBA lower (if corona were present). These lower levels could be masked by ambient noise on and off the right-of-way.

## 7.4 Discussion

The calculated foul-weather corona noise levels for the proposed line would be less than those under the existing conditions and comparable to or less than those from existing 230-kV lines in Oregon. During fair weather, noise from the conductors might be perceivable on the right-of-way, but beyond the right-of-way it would likely be masked or so low as to not be perceived even during foul weather when ambient noise is higher.

Off the right-of-way, the levels of audible noise from the proposed line would be well below the 55 dBA level that can produce interference with speech outdoors. Since residential buildings provide significant sound attenuation (-12 dBA with windows open; -24 dBA with windows closed), the noise levels off the right-of-way would be well below the 45 dBA level required for interference with speech indoors and well below the 35 dBA level where sleep interference can occur (EPA, 1973; EPA, 1978). Since corona is a foul-weather phenomenon, people tend to be inside with windows possibly closed, providing additional attenuation when corona noise is present. In addition, ambient noise levels can be high during such periods (due to rain hitting foliage or buildings), and can mask corona noise.

The 39-dBA and 47-dBA levels would meet the BPA design criterion and, hence, the Oregon Noise Control Regulations for transmission lines. The 2 dBA decrease in noise at the edge of the right-of-way associated with the proposed line would probably not be discernible.

The computed annual  $L_{dn}$  level for transmission lines operating in areas with about 22% foul weather is about  $L_{dn} = L_{50} + 1$  dB (Bracken, 1987). Therefore, assuming such conditions in the Santiam - Bethel area, the estimated  $L_{dn}$  at the edge of the right-of-way would be approximately 40 or 48 dBA, which is below the EPA  $L_{dn}$  guideline of 55 dBA.

## 7.5 Conclusion

Along the proposed line route, there would be slight decreases, or no change, in the perceived noise above ambient levels during foul weather at the edges of the right-of-way. Along the existing corridor, the corona-generated noise during foul weather would be masked to some extent by naturally occurring sounds such as wind and rain on foliage. During fair weather, the noise off the right-of-way from the proposed line would probably not be detectable above ambient levels. However, noise from the existing 500-kV line could be perceived as much as under existing conditions. The noise levels from the proposed line would be below levels identified as causing interference with speech or sleep. The audible noise from the transmission line would be below EPA guideline levels and would meet the BPA design criterion that complies with the Oregon State noise regulations.

## 8.0 Electromagnetic Interference

### 8.1 Basic Concepts

Corona on transmission-line conductors can also generate electromagnetic noise in the frequency bands used for radio and television signals. The noise can cause radio and television interference (RI and TVI). In certain circumstances, corona-generated electromagnetic interference (EMI) can also affect communications systems and other sensitive receivers. Interference with electromagnetic signals by corona-generated noise is generally associated with lines operating at voltages of 345 kV or higher. This is especially true of interference with television signals. The 1.600-in. (4.1-cm) diameter conductor used

in the design of the proposed 230-kV line will mitigate corona generation and thus keep radio and television interference levels at acceptable levels.

Spark gaps on distribution lines and on low-voltage wood-pole transmission lines are a more common source of RI/TVI than is corona from high-voltage electrical systems. This gap-type interference is primarily a fair-weather phenomenon caused by loose hardware and wires. The proposed transmission line would be constructed with modern hardware that eliminates such problems and therefore minimizes gap noise. Consequently, this source of EMI is not anticipated for the proposed line.

No state has limits for either RI or TVI. In the United States, electromagnetic interference from power transmission systems is governed by the Federal Communications Commission (FCC) Rules and Regulations presently in existence (FCC, 1988). A power transmission system falls into the FCC category of "incidental radiation device," which is defined as "a device that radiates radio frequency energy during the course of its operation although the device is not intentionally designed to generate radio frequency energy." Such a device "shall be operated so that the radio frequency energy that is emitted does not cause harmful interference. In the event that harmful interference is caused, the operator of the device shall promptly take steps to eliminate the harmful interference." For purposes of these regulations, harmful interference is defined as: "any emission, radiation or induction which endangers the functioning of a radio navigation service or of other safety services or seriously degrades, obstructs or repeatedly interrupts a radio communication service operating in accordance with this chapter" (FCC, 1988: Vol II, part 15. 47CFR, Ch. 1).

Electric power companies have been able to work quite well under the present FCC rule because harmful interference can generally be eliminated. It has been estimated that more than 95% of power-line sources that cause interference are due to gap-type discharges. These can be found and completely eliminated, when required to prevent interference (USDOE, 1980). Complaints related to corona-generated interference occur infrequently. This is especially true with the advent of cable television and satellite television, which are not subject to corona-generated interference. Mitigation of corona-generated interference with conventional radio and television receivers can be accomplished in several ways, such as use of a directional antenna or relocation of an existing antenna (USDOE, 1977; USDOE, 1980; Loftness et al., 1981).

## **8.2 Radio Interference (RI)**

Radio reception in the AM broadcast band (535 to 1605 kilohertz (kHz)) is most often affected by corona-generated EMI. FM radio reception is rarely affected. Generally, only residences very near to transmission lines can be affected by RI. The IEEE Radio Noise Design Guide identifies an acceptable limit of fair-weather RI as expressed in decibels above 1 microvolt per meter (dB $\mu$ V/m) of about 40 dB $\mu$ V/m at 100 ft. (30 m) from the outside conductor (IEEE Committee Report, 1971). As a general rule, average levels during foul weather (when the conductors are wet) are 16 to 22 dB $\mu$ V/m higher than average fair-weather levels.

## **8.3 Predicted RI Levels**

Table 9 gives the predicted fair- and foul-weather RI levels at 100 ft. (30 m) from the outside conductor for the proposed 230-kV line in the two corridor configurations. Median foul-weather levels would be about 17 dB higher than the fair-weather levels. The predicted L<sub>50</sub> fair-weather level at the edge of the right-of-way is 34 dB $\mu$ V/m for 235-kV line operation; at 100 ft. (30 m) from the outside conductor, the level is 26 dB $\mu$ V/m. Predicted fair-weather L<sub>50</sub> levels are lower than that from the existing 230-kV Santiam - Chemawa 230-kV line. Predictions indicate that fair-weather RI will meet the IEEE

40 dB $\mu$ V/m criterion at distances greater than about 10 ft. (3 m) from the outside conductor of the proposed line.

#### **8.4 Television Interference (TVI)**

Corona-caused TVI occurs during foul weather and is generally of concern for transmission lines with voltages of 345 kV or above, and only for conventional receivers within about 600 ft. (183 m) of a line. As is the case for RI, gap sources on distribution and low-voltage transmission lines are the principal observed sources of TVI. The use of modern hardware and construction practices for the proposed line would minimize such sources.

#### **8.5 Predicted TVI Levels**

Table 10 shows TVI levels predicted at 100 ft. (30 m) from the outside conductor of the proposed line operating at 235 kV and from existing lines. At this distance, the foul-weather TVI level predicted for the proposed line is 10 dB $\mu$ V/m. This level is lower than that from the existing Santiam - Chemawa 230-kV line. Replacement of the existing line with the proposed line will reduce TVI levels along the right-of-way.

Other forms of TVI from transmission lines are signal reflection (ghosting) and signal blocking caused by the relative locations of the transmission structure and the receiving antenna with respect to the incoming television signal. The proposed structures are steel and larger than the existing wood structures; they could cause reflection or ghosting and affect reception in rare instances. Television systems that operate at higher frequencies, such as satellite receivers, are not affected by corona-generated TVI. Cable television systems are similarly unaffected.

Interference with television reception can be corrected by any of several approaches: improving the receiving antenna system; installing a remote antenna; installing an antenna for TV stations less vulnerable to interference; connecting to an existing cable system; or installing a translator (cf. USDOE, 1977). BPA has an active program to identify, investigate, and mitigate legitimate RI and TVI complaints. It is anticipated that any instances of TVI caused by the proposed line could be effectively mitigated.

#### **8.6 Interference with Other Devices**

Corona-generated interference can conceivably cause disruption on other communications bands such as the citizen's (CB) and mobile bands. However, mobile-radio communications are not susceptible to transmission-line interference because they are generally frequency modulated (FM). Similarly, cellular telephones operate at a frequency of about 900 MHz, which is above the frequency where corona-generated interference is prevalent. In the unlikely event that interference occurs with these or other communications, mitigation can be achieved with the same techniques used for television and AM radio interference. However, the addition of the proposed line would lower interference levels in the corridor; consequently, no impact is anticipated.

#### **8.7 Conclusion**

Predicted EMI levels for the proposed 230-kV transmission line are lower than those that already exist 230-kV lines; no impacts of corona-generated interference on radio, television, or other reception are anticipated above those already present. Furthermore, if interference should occur, there are various methods for correcting it: BPA has a program to respond to legitimate complaints.

## 9.0 Other Corona Effects

Corona is visible as a bluish glow or as bluish plumes. On the proposed 230-kV line, corona levels would be very low, so that corona on the conductors would be observable only under the darkest conditions and only with the aid of binoculars, if at all. Without a period of adaptation for the eyes and without intentional looking for the corona, it would not be noticeable.

When corona is present, the air surrounding the conductors is ionized and many chemical reactions take place, producing small amounts of ozone and other oxidants. Ozone is approximately 90% of the oxidants, while the remaining 10% is composed principally of nitrogen oxides. The national primary ambient air quality standard for photochemical oxidants, of which ozone is the principal component, is 235 micrograms/cubic meter) or 120 parts per billion. The maximum incremental ozone levels at ground level produced by corona activity on the proposed transmission line during foul weather would be much less than 1 part per billion. This level is insignificant when compared with natural levels and fluctuations in natural levels.

## 10.0 Summary

Electric and magnetic fields from the proposed transmission line have been characterized using well-known techniques accepted within the scientific and engineering community. The expected electric-field levels from the proposed line at minimum design clearance would be less than those from the existing line in the corridor and comparable to, or less than, those from other 230-kV lines in Oregon and elsewhere. The expected magnetic-field levels from the proposed line would be less than those from the existing line that would be replaced and comparable to, or less than, those from other 230-kV lines in Oregon and elsewhere.

The peak electric field expected under the proposed line would be 2.5 kV/m; the maximum value at the edge of the right-of-way would be about 0.4 kV/m. Clearances at road crossings would be increased to reduce the peak electric-field value to 1.7 kV/m.

Under maximum current conditions, the maximum magnetic fields under the proposed line would be 96 mG; at the edge of the right-of-way nearest to the proposed 230-kV line, the magnetic field would be 29 or 26 mG, depending on whether the line parallels an existing 500-kV line or not.

The electric and magnetic fields from the proposed line would meet regulatory limits for public exposure in Oregon and other states with limits. As long as cardiac pacemaker wearers are discouraged from using the right-of-way, the field levels meet the guidelines for exposure established by ACGIH and ICNIRP.

Short-term effects from transmission-line fields are well understood and can be mitigated. Nuisance shocks arising from electric-field induced currents and voltages could be perceivable on the right-of-way of the proposed line. BPA will ground permanent conducting objects during and after construction to mitigate against such occurrences. Since the fields from the proposed line are less than those from the existing line on the corridor, the potential for such effects could be reduced.

Corona-generated audible noise from the line would be less than from the existing 230-kV transmission lines on the corridor. Audible noise levels would be in compliance with noise regulations in Oregon and would be below levels specified in EPA guidelines.



Corona-generated electromagnetic interference from the proposed line would be less than that from the existing 230-kV line on the corridor and would remain below limits identified as acceptable. In the unlikely event that legitimate complaints arise, BPA has a mitigation program to identify and correct reception problems.

## List of References Cited

- ACGIH (American Conference of Governmental Industrial Hygienists). 2000. 2000 TLVs and BEIs: Threshold Limit Values for Chemical Substances and Physical Agents and Biological Exposure Indices. American Conference of Governmental Industrial Hygienists, Cincinnati. 192 pages.
- Baishiki, R.S.; Johnson, G.B.; Zaffanella, L.E.; Bracken, T.D.; Sussman, S.S.; Rauch, G.B.; and Silva, J.M. 1990. Studies of Power System Magnetic Fields: Characterization of Sources in Residential Environments, Measurement of Exposure, Influence On Computer Screens. (36-104) CIGRE, Paris, France. 10 pages.
- Banfai, B.; Karady, G.G.; Kim, C.J.; and Maracas, K.B. 2000. Magnetic field effects on CRT computer monitors. *IEEE Trans. on Power Delivery* 15, 307-312.
- Bassen, H.; Casamento, J.; and Crawl, B. 1991. Reduction of electric and magnetic field emissions from electric blankets (Meeting abstract). *In: Bioelectromagnetics Society, 13th Annual Meeting, 23-27 June, Salt Lake City. Bioelectromagnetics Society, New York, 20.*
- Bowman, J.D.; Garabrant, D.H.; Sobel, E.; and Peters, J.M. June 1988. Exposures to Extremely Low Frequency (ELF) Electromagnetic Fields in Occupations With Elevated Leukemia Rates. *Applied Industrial Hygienics*, 3(6, June):189-194.
- Bracken, T.D. 1987. Audible Noise from High Voltage Transmission Facilities. A Briefing Paper Prepared for State of Florida Department of Environmental Regulation. (DER Contract No. SP122) State of Florida Department of Environmental Regulation.
- Bracken, T.D. 1990. The EMDEX Project: Technology Transfer and Occupational Measurements, Volumes 1-3 Interim Report. EPRI Report EN-7048. (EPRI EN-7048) Electric Power Research Institute, Palo Alto, CA.
- Chartier, V.L. April 1983. Empirical Expressions for Calculating High Voltage Transmission Corona Phenomena, First Annual Seminar Technical Career Program for Professional Engineers. Bonneville Power Administration, Portland, Oregon. April 1983, 75-82.
- Chartier, V.L.; and Stearns, R.D. January 1981. Formulas for Predicting Audible Noise from Overhead High Voltage AC and DC Lines. *IEEE Transactions on Power Apparatus and Systems*, PAS-100(No. 1, January 1981):121-129.
- Dabkowski, J.; and Taflove, A. May/June 1979. Prediction Method for Buried Pipeline Voltages Due to 60 Hz AC Inductive Coupling. Part II: Field Test Verification. *IEEE Transactions on Power Apparatus and Systems*, PAS-98(3, May/June):788-794.
- Deno, D.W.; and Zaffanella, L. 1982. Field effects of overhead transmission lines and stations. Chap. 8. *In: Transmission Line Reference Book: 345 KV and Above. Second ed. (Ed: LaForest, J.J.). Electric Power Research Institute, Palo Alto, CA, 329-419.*
- EPA (Environmental Protection Agency). July 1973. Public Health and Welfare Criteria for Noise. (No. 500/9-73-002, July 27, 1973.) U.S. Environmental Protection Agency, Washington, D.C.

- EPA. 1974. Information On Levels of Environmental Noise Requisite to Protect Public Health and Welfare With an Adequate Margin of Safety. (No. PB-239 429.) U.S. Environmental Protection Agency, Washington, D.C.
- EPA. 1978. Protective Noise Levels. Condensed Version of EPA Levels Document. (No. PB82-138827) U.S Environmental Protection Agency, Washington, DC.
- FCC (Federal Communications Commission). 1988. Federal Communications Commission Rules and Regulations. 10-1-88 ed. Vol. II part 15, 47 CFR, Ch. 1.
- Florig, H.K.; and Hoburg, J.F. 1988. Electric and Magnetic Field Exposure Associated With Electric Blankets. Project Resume. Contractor's Review. U.S. Department of Energy/Electric Power Research Institute.
- Florig, H.K.; Hoburg, J.F.; and Morgan, M.G. April 1987. Electric Field Exposure from Electric Blankets. IEEE Transactions on Power Delivery, PWRD-2(2, April):527-536.
- Gauger, J. September 1985. Household Appliance Magnetic Field Survey. IEEE Transactions on Power Apparatus and Systems, 104(9, September):2436-2445.
- Harvey, S.M. 1983. Analysis of operator exposure to electric fields from video display units. Chap. 2. In Video Display Units--Characterization of Electric and Magnetic Fields. (Ontario Hydro Research Division Report # 83-503-K) (Ed: Walsh, M.L.). Ontario Hydro, Toronto, 31-56.
- Heroux, P. 1987. 60-Hz Electric and Magnetic Fields Generated By a Distribution Network. Bioelectromagnetics, 8(2):135-148.
- ICNIRP (International Committee on Non-ionizing Radiation Protection). April 1998. Guidelines for Limiting Exposure to Time-Varying Electric, Magnetic, and Electromagnetic Fields (Up to 300 GHz). Health Physics, 74(4, April):1-32.
- IEEE (Institute of Electrical and Electronics Engineers, Inc.). 1978. Electric and Magnetic Field Coupling from High Voltage AC Power Transmission Lines -- Classification of Short-Term Effects On People. IEEE Transactions on Power Apparatus and Systems, PAS-97:2243-2252.
- IEEE. 1987. IEEE Standard Procedures for Measurement of Power Frequency Electric and Magnetic Fields from AC Power Lines. ANSI/IEEE Std. 644-1987, New York, NY.
- IEEE. 1990. National Electrical Safety Code. 1990 ed. Institute of Electrical and Electronics Engineers, Inc., New York, NY. 432 pages.
- IEEE Committee Report. March/April 1971. Radio Noise Design Guide for High Voltage Transmission Lines. IEEE Transactions on Power Apparatus and Systems, PAS-90(No. 2, March/April):833-842.
- IEEE Committee Report. October 1982. A Comparison of Methods for Calculating Audible Noise of High Voltage Transmission Lines. IEEE Transactions on Power Apparatus and Systems, 101(10, October):4090-4099.
- ITT Research Institute. 1984. Representative Electromagnetic Field Intensities Near the Clam Lake (WI) and Republic (MI) ELF Facilities. Report Prepared for Naval Electronics Systems

- Command, PME 110 E Washington, D.C. 20360. (Under contract N00039-84-C0070.) ITT Research Institute, Chicago, IL. 60 pages.
- Jaffa, K.C.; and Stewart, J.B. March 1981. Magnetic Field Induction from Overhead Transmission and Distribution Power Lines On Buried Irrigation Pipelines. *IEEE Transactions on Power Apparatus and Systems*, PAS-100(3, March):990-1000.
- Keesey, J.C.; and Letcher, F.S. 1969. Minimum Thresholds for Physiological Responses to Flow of Alternating Electric Current Through the Human Body At Power-Transmission Frequencies. (Report No. 1) Naval Medical Research Institute, Project MR 005.08-0030B, Bethesda, MD. 25 pages.
- Loftness, M.O.; Chartier, V.L.; and Reiner, G.L. 1981. EMI Correction Techniques for Transmission Line Corona. (August 18-20, 1981, pp. 351-361.) Proceedings of the 1981 IEEE International Symposium on Electromagnetic Compatibility, Boulder, CO.
- Maddock, B.J. September 1992. Guidelines and Standards for Exposure to Electric and Magnetic Fields At Power Frequencies. (Panel 2-05, CIGRE meeting August 30-September 5, 1992) CIGRE, Paris.
- Olsen, R.G.; Schennum, S.D.; and Chartier, V.L. April 1992. Comparison of Several Methods for Calculating Power Line Electromagnetic Interference Levels and Calibration With Long Term Data. *IEEE Transactions on Power Delivery*, 7(April, 1992):903-913.
- Oregon, State of. 1980. Oregon Administrative Rules Chapter 345, Division 80. Energy Facility Siting Council standards relating to public health and safety, 934-80-055.
- Perry, D. 1982. Sound Level Limits from BPA Facilities. BPA memorandum, May 26, 1982; Department of Environmental Quality, Noise Control Regulations, Chapter 340, Oregon Administrative Rules, Division 35, March 1, 1978.
- Reilly, J.P. 1979. Electric Field Induction on Long Objects—A Methodology for Transmission Line Impact Studies. *IEEE Transactions on Power Apparatus and Systems*, PAS-98(6, Nov/Dec):1841-1852.
- Sheppard, A.R.; and Eisenbud, M. 1977. Biological Effects of Electric and Magnetic Fields of Extremely Low Frequency. New York University Press, New York.
- Silva, M.; Hummon, N.; Rutter, D.; and Hooper, C. 1989. Power Frequency Magnetic Fields in the Home. *IEEE Transactions on Power Delivery*, 4:465-478.
- Stoppa, G.J.; and Janischewskyj, W. 1979. Epidemiological Study of Workers Maintaining HV Equipment and Transmission Lines in Ontario. (Canadian Electrical Association Research Report) Canadian Electrical Association, Montreal. 82 pages.
- Taflove, A.; and Dabkowski, J. May/June 1979. Prediction Method for Buried Pipeline Voltages Due to 60 Hz AC Inductive Coupling. Part I: Analysis. *IEEE Transactions on Power Apparatus and Systems*, PAS-98(3, May/June):780-787.

- TDHS Report. March 1989. EMF Rule Becomes Law; Hillsborough County Commission Challenges. Transmission/Distribution Health & Safety Report, 7(9, 31 March):1-3.
- TDHS Report. August 1990. Updates: New York. Transmission/Distribution Health & Safety Report, 8(7, 31 August):4.
- USDOE (U.S. Department of Energy), Bonneville Power Administration. March 1977. A Practical Handbook for the Location, Prevention and Correction of Television Interference from Overhead Power Lines. Portland, OR.
- USDOE, Bonneville Power Administration. May 1980. A Practical Handbook for the Correction of Radio Interference from Overhead Powerlines and Facilities. (May 1980.) Portland, OR.
- USDOE, Bonneville Power Administration. 1995. Living and Working Around High-Voltage Power Lines. (DOE/BP-799). Portland, OR. 9 pages.
- USDOE, Bonneville Power Administration. 1996. Electrical and Biological Effects of Transmission Lines: A Review. (DOE/BP 2938 December 1996 1M) Portland, OR.
- USDOE, Bonneville Power Administration. undated. "Corona and Field Effects" Computer Program (Public Domain Software). Bonneville Power Administration, P.O. Box 491-ELE, Vancouver, WA 98666.
- Zaffanella, L.E. 1993. Survey of Residential Magnetic Field Sources. Vol. 1: Goals, results, and conclusions. (EPRI TR-102759-V1, Project 3335-02) Electric Power Research Institute, Palo Alto, CA.
- Zaffanella, L.E.; and Kalton, G.W. 1998. Survey of personal magnetic field exposure, Phase II: 1000-person survey. Interim Report. EMF RAPID Program Engineering Project #6. Eneritech Consultants, Lee, MA.

## **List of Preparers**

T. Dan Bracken was the principal author of this report. He received a B.S. degree in physics from Dartmouth College and M.S. and Ph.D. degrees in physics from Stanford University. Dr. Bracken has been involved with research on and characterization of electric- and magnetic-field effects from transmission lines for over 27 years, first as a physicist with the Bonneville Power Administration (BPA) (1973 - 1980) and since then as a consultant. His firm, T. Dan Bracken, Inc., offers technical expertise in areas of electric- and magnetic-field measurements, instrumentation, environmental effects of transmission lines, exposure assessment and project management. Joseph Dudman of T. Dan Bracken, Inc., provided data entry, graphics, and clerical support in the preparation of the report.

Judith H. Montgomery of Judith H. Montgomery/Communications served as technical editor for the report. She holds an A.B. degree in English literature from Brown University, 1966; and a Ph.D. degree in American literature from Syracuse University, 1971. Dr. Montgomery has provided writing, editing, and communications services to government and industry for 20 years. Her experience includes preparation of National Environmental Policy Act documents and technical papers dealing with transmission-line environmental impact assessment and other utility-related activities.

(This page intentionally left blank.)

**Table 1: Physical and electrical characteristics of Santiam - Bethel Project corridors**

	New Line	Existing Corridors	
Configuration	I	I	II
Description	Santiam - Bethel/Santiam - Chemawa 230-kV	Santiam - Chemawa 230-kV	Marion - Santiam No. 1 & No. 2 500-kV
Voltage, kV Maximum/Average <sup>1</sup>	242/235	242/235	550/540, 0/0
Peak Current, A Existing/Proposed	-/755, -/644	1043/-	-889/-992, 0/0
Electric Phasing	B C A B C A	C B A	B B A C A C
Clearance, ft. Minimum/Average <sup>1</sup>	31/43	31/43	38/47
Centerline Distance from Santiam - Bethel, ft.	-	-	125
Centerline distance to edge of right-of-way (ROW), ft.	62.5	62.5	82.5
Tower configuration	Vertical double-circuit	Horizontal	Delta double-circuit
Phase spacing, ft.	24.5H, 40.5H 18V	27H	25.5H, 36.75V
Conductor: #/Diameter, in.	1/1.600	1/1.100	3/1.302

<sup>1</sup> Average voltage and average clearance used for corona calculations.

**Table 2: Possible corridors for Santiam - Bethel Project**

Configuration	Description of other lines in corridor with Santiam - Bethel/Santiam - Chemawa 230-kV line	Miles
I	Santiam - Bethel/Santiam - Chemawa 230-kV double-circuit line only	15.2
II	BPA Marion - Santiam 500-kV No. 1 and No. 2 double circuit line	1.5



**Table 3: Calculated electric fields for configurations of the proposed Santiam - Bethel/Santiam - Chemawa 230-kV line operated at maximum voltage.** Configurations are described in Tables 1 and 2.

a) **Configuration I: Santiam - Bethel/Santiam - Chemawa 230-kV line only**

Configuration	Proposed I		Existing	
ROW width, ft. (m)	125 (38)		125 (38)	
Line	Santiam - Bethel/Santiam - Chemawa 230-kV		Santiam - Chemawa 230-kV	
Clearance	Min.	Avg.	Min.	Avg.
Peak field, kV/m	2.5	1.5	3.0	1.8
Edge of ROW, kV/m	0.3	0.4	1.3	1.1

b) **Configuration II: Santiam - Bethel/Santiam - Chemawa 230-kV and Marion - Santiam 500-kV No. 1 and No. 2 lines**

Configuration	Proposed II				Existing			
ROW width, ft. (m)	270 (82)				270 (82)			
Line	Santiam - Bethel/ Santiam - Chemawa 230-kV		Marion - Santiam No. 1 and No. 2 500-kV		Santiam - Chemawa 230-kV		Marion - Santiam No. 1 and No. 2 500-kV	
Clearance	Min.	Avg.	Min.	Avg.	Min.	Avg.	Min.	Avg.
Peak field, kV/m	2.4	1.4	8.1	4.5	3.0	1.8	8.1	4.5
Edge of ROW, kV/m	0.3	0.3	2.5	2.6	1.3	1.1	2.5	2.6

**Table 4: Calculated magnetic fields for configurations of the proposed Santiam - Bethel/Santiam - Chemawa 230-kV line operated at maximum current.** Configurations are described in Tables 1 and 2.

a) **Configuration I: Santiam - Bethel/Santiam - Chemawa 230-kV line only**

Configuration	Proposed I		Existing	
ROW width, ft. (m)	125 (38)		125 (38)	
Line	Santiam - Bethel/Santiam - Chemawa 230-kV		Santiam - Chemawa 230-kV	
Clearance	Min.	Avg.	Min.	Avg.
Peak field, mG	87	50	218	139
Edge of ROW, mG	26	24	78	62

b) **Configuration II: Santiam - Bethel/Santiam - Chemawa 230-kV and Marion - Santiam 500-kV No. 1 and No. 2 lines**

Configuration	Proposed II				Existing			
ROW width, ft. (m)	270 (82)				270 (82)			
Line	Santiam - Bethel/ Santiam - Chemawa 230-kV		Marion - Santiam No. 1 and No. 2 500-kV		Santiam - Chemawa 230-kV		Marion - Santiam No. 1 and No. 2 500-kV	
Clearance	Min.	Avg.	Min.	Avg.	Min.	Avg.	Min.	Avg.
Peak field, mG	94	58	130	67	211	135	108	57
Edge of ROW, kV/m	29	24	52	39	80	65	50	38

**Table 5: States with transmission-line field limits**

STATE AGENCY	WITHIN RIGHT-OF-WAY	AT EDGE OF RIGHT-OF-WAY	COMMENTS
<b>a. 60-Hz ELECTRIC FIELD LIMIT, kV/m</b>			
Florida Department of Environmental Regulation	8 ( 230 kV) 10 (500 kV)	2	Codified regulation, adopted after a public rulemaking hearing in 1989.
Minnesota Environmental Quality Board	8	–	12-kV/m limit on the High-Voltage Direct Current (HVDC) nominal electric field.
Montana Board of Natural Resources and Conservation	7 <sup>1</sup>	1 <sup>2</sup>	Codified regulation, adopted after a public rulemaking hearing in 1984.
New Jersey Department of Environmental Protection	–	3	Used only as a guideline for evaluating complaints.
New York State Public Service Commission	11.8 (7,11) <sup>1</sup>	1.6	Explicitly implemented in terms of a specified right-of-way width.
Oregon Facility Siting Council	9	–	Codified regulation, adopted after a public rulemaking hearing in 1980.
<b>b. 60-Hz MAGNETIC FIELD LIMIT, mG</b>			
Florida Department of Environmental Regulation	–	150 ( 230 kV) 200 (500 kV)	Codified regulations, adopted after a public rulemaking hearing in 1989.
New York State Public Service Commission	–	200	Adopted August 29, 1990.

- 1 At road crossings
- 2 Landowner may waive limit

Sources: TDHS Report, 1989;TDHS Report, 1990

**Table 6: Common noise levels**

Sound Level, dBA	Noise Source or Effect
128	Threshold of pain
108	Rock-and-roll band
80	Truck at 50 ft. (15.2 m)
70	Gas lawnmower at 100 ft. (30 m)
60	Normal conversation indoors
50	Moderate rainfall on foliage
50	Edge of 500-kV right-of-way during rain
40	Refrigerator
25	Bedroom at night
0	Hearing threshold

Adapted from: USDOE, 1996.

**Table 7: Typical sound attenuation (in decibels) provided by buildings**

	Windows opened	Windows closed
<b>Warm climate</b>	12	24
<b>Cold climate</b>	17	24

Source: EPA, 1978.

**Table 8: Predicted foul-weather audible noise (AN) levels at edge of right-of-way (ROW) for proposed Santiam - Bethel/Santiam - Chemawa 230-kV line.** AN levels expressed in decibels on the A-weighted scale (dBA). L<sub>50</sub> and L<sub>5</sub> denote the levels exceeded 50 and 5 percent of the time, respectively. For the parallel-line configurations<sup>1</sup>, the AN level at the edge of the proposed Santiam - Bethel ROW is given first.

Configuration <sup>1</sup>	Foul-weather AN					
	Proposed			Existing		
	ROW ft. (m)	L <sub>50</sub> , dBA	L <sub>5</sub> , dBA	ROW ft. (m)	L <sub>50</sub> , dBA	L <sub>5</sub> , dBA
I	125 (38)	39	43	125 (38)	41	44
II	270 (82)	47, 52	51, 55	270 (82)	47, 52	51, 55

1 Configurations are described in Tables 1 and 2.

**Table 9: Predicted fair-weather radio interference (RI) levels at 100 feet (30.5 m) from the outside conductor of the proposed Santiam - Bethel/Santiam - Chemawa 230-kV line.** RI levels given in decibels above 1 microvolt/meter (dBμV/m) at 1.0 MHz. L<sub>50</sub> denotes level exceeded 50 percent of the time. For the parallel-line configurations the RI level on the side of the proposed Santiam - Bethel ROW is given first.

Configuration <sup>1</sup>	Fair-weather RI	
	Proposed	Existing
	L <sub>50</sub> , dBμV/m	L <sub>50</sub> , dBμV/m
I	26	28
II	30, 41	30, 41

1 Configurations are described in Tables 1 and 2.

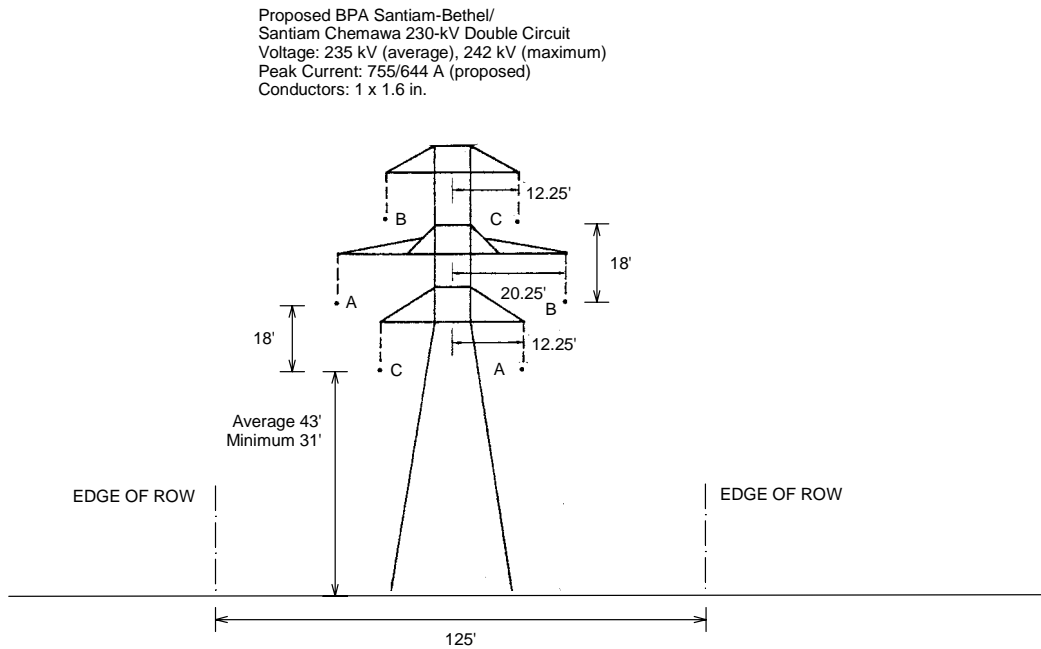
**Table 10: Predicted maximum foul-weather television interference (TVI) levels predicted at 100 feet (30.5 m) from the outside conductor of the proposed Santiam - Bethel/Santiam - Chemawa 230-kV line.** TVI levels given in decibels above 1 microvolt/meter (dB $\mu$ V/m) at 75 MHz. For the parallel-line configurations, the TVI level on the side of the proposed Santiam - Bethel ROW is given first.

<b>Configuration<sup>1</sup></b>	<b>Foul-weather TVI</b>	
	<b>Proposed</b>	<b>Existing</b>
	<b>L<sub>5</sub> (foul), dB<math>\mu</math>V/m</b>	<b>L<sub>5</sub> (foul), dB<math>\mu</math>V/m</b>
<b>I</b>	10	15
<b>II</b>	12, 27	15, 27

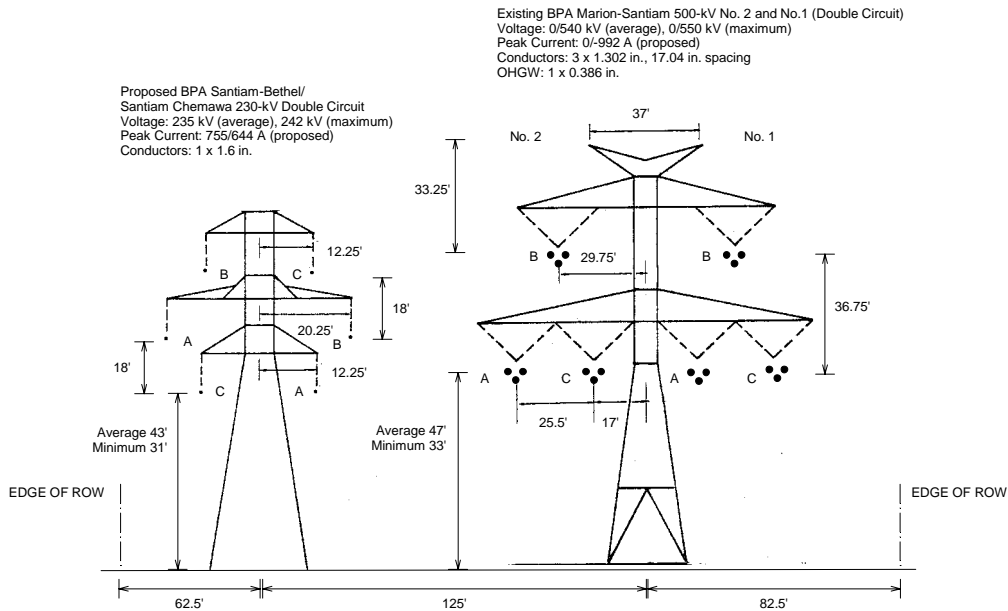
1 Configurations are described in detail in Tables 1 and 2.

**Figure 1: Configurations for proposed Santiam - Bethel/Santiam - Chemawa 230-kV line: a) proposed line with no parallel lines ( Configuration I); and b) proposed line with parallel 500-kV line (Configuration II).**

a) Proposed line with no parallel lines (Configuration I) (not to scale)

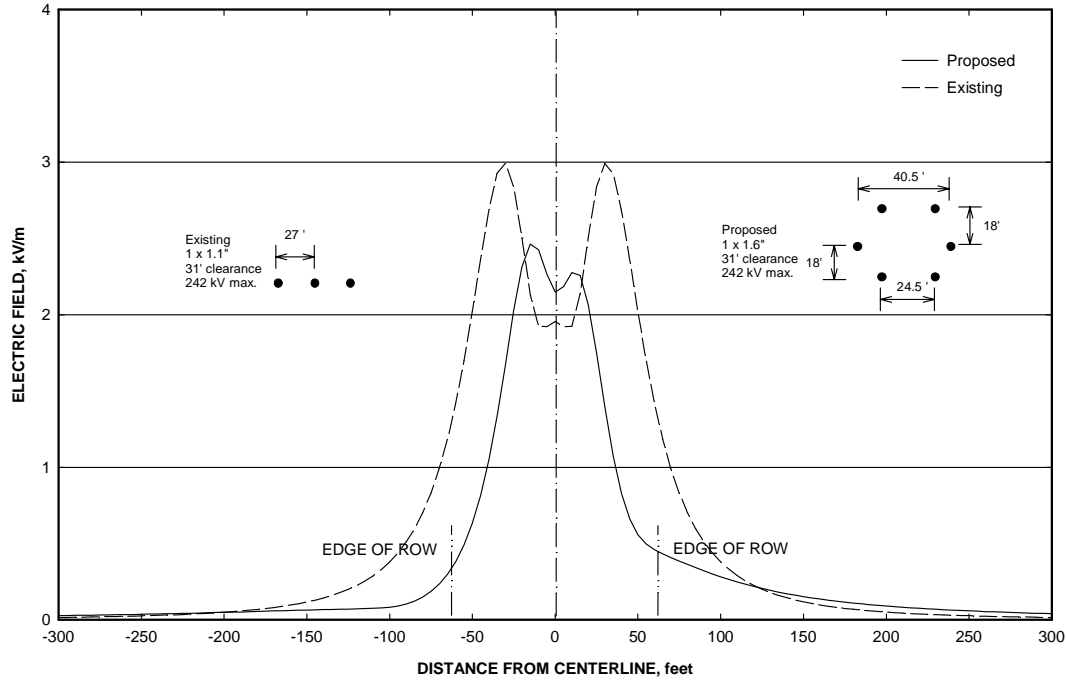


b) Proposed line with parallel 500-kV line (Configuration II) (not to scale)

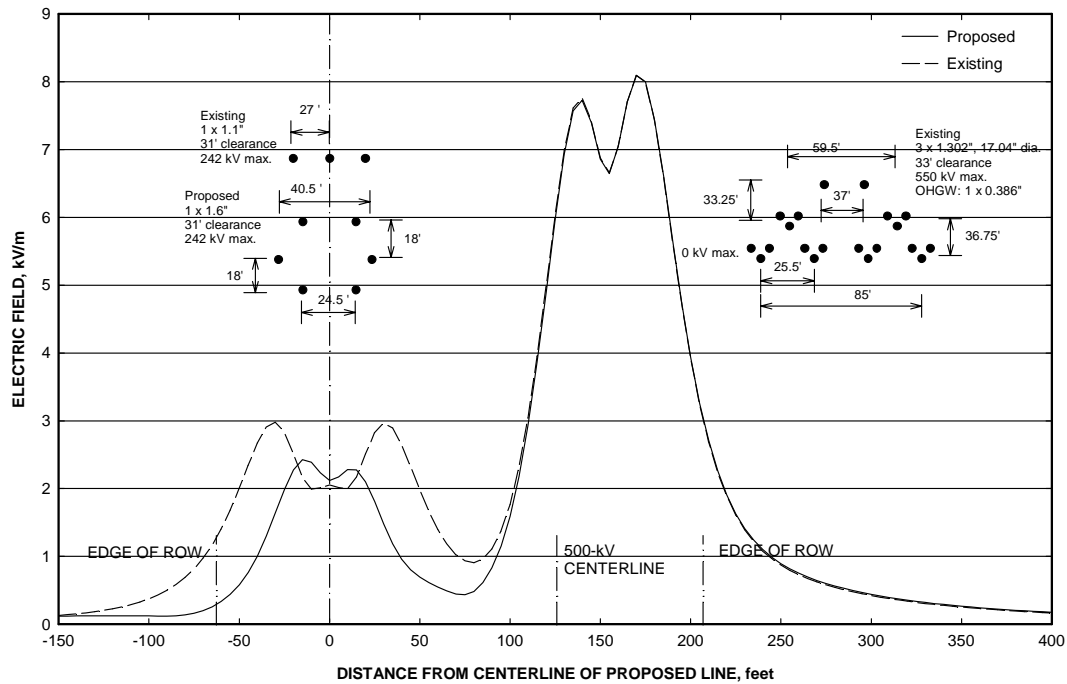


**Figure 2: Electric-field profiles for configurations of proposed Santiam - Bethel/Santiam - Chemawa 230-kV line: a) proposed line with no parallel line (Configuration I); and b) proposed line with parallel 500-kV line (Configuration II). Fields for maximum voltage and minimum clearances are shown.**

a) Proposed line with no parallel line (Configuration I).



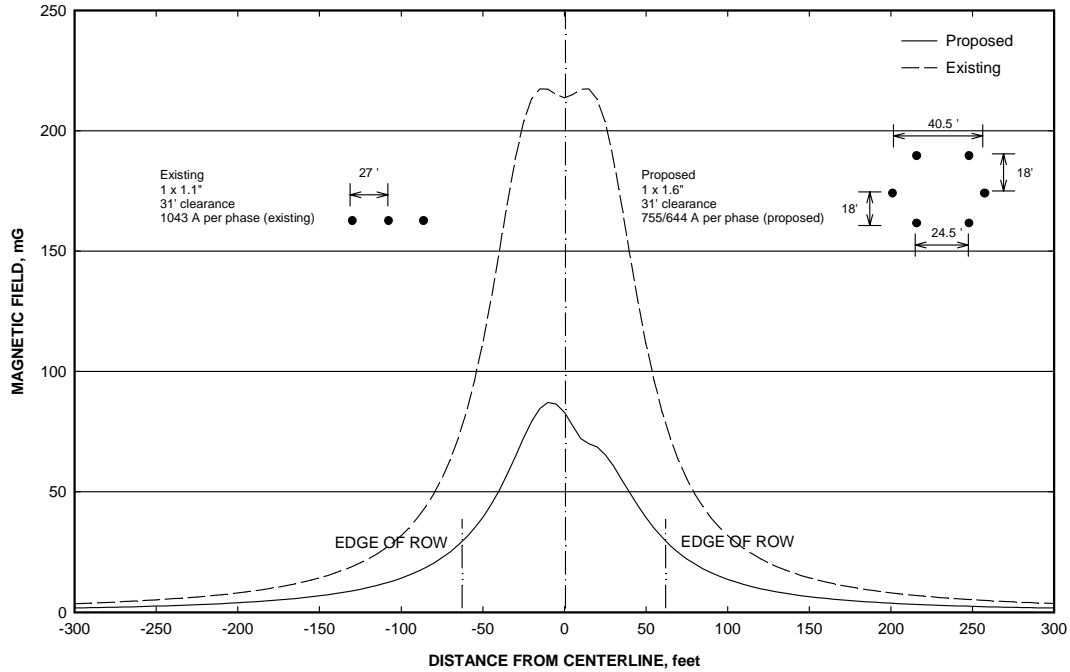
b) Proposed line with parallel 500-kV line (Configuration II)



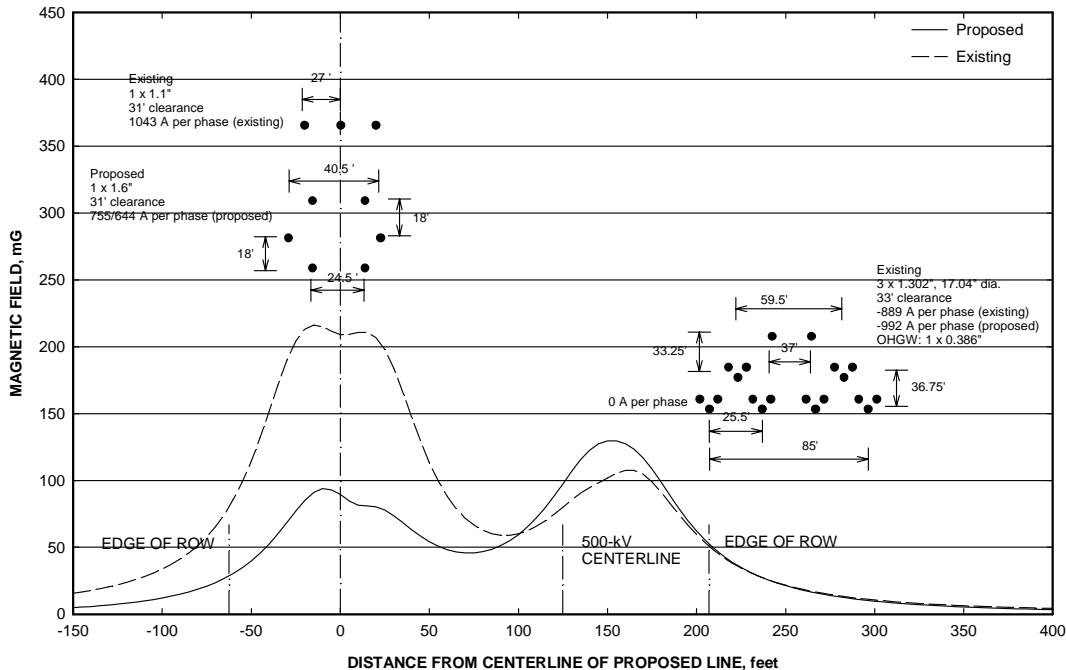


**Figure 3: Magnetic-field profiles for configurations of the proposed Santiam - Bethel/Santiam - Chemawa 230-kV line for maximum current conditions: a) proposed line with no parallel line (Configuration I); and b) proposed line with parallel 500-kV line (Configuration II).**

a) Proposed line with no parallel line (Configuration I)



b) Proposed line with parallel 500-kV line (Configuration II).



**SANTIAM-BETHEL TRANSMISSION PROJECT**

**APPENDIX B:**

**ASSESSMENT OF RESEARCH REGARDING EMF AND  
HEALTH AND ENVIRONMENTAL EFFECTS**

June 2001

Prepared by

**Exponent™**

and

**T. Dan Bracken, Inc.**

for

**Bonneville Power Administration**



## **Table of Contents**

1.0	Introduction .....	1
2.0	Health .....	1
2.1	The NIEHS Report and Research Program.....	1
2.2	Update of Research Related to Cancer.....	2
2.2.1	Epidemiology Studies of Children .....	2
2.2.2	Epidemiology Studies of Adults .....	5
2.2.3	Laboratory Studies of EMF.....	6
2.2.4	Summary Regarding Cancer .....	7
2.3	Research Related to Reproduction .....	7
2.4	Other Recent Reviews by Scientific Advisory Groups .....	7
2.4.1	National Radiological Protection Board of Great Britain (NRPB) Advisory Group on Non-Ionising Radiation .....	8
2.4.2	Health Council of the Netherlands.....	8
2.4.3	Institution of Electrical Engineers (IEE) of Great Britain.....	9
3.0	Ecological Research.....	9
3.1	Fauna.....	9
3.2	Flora .....	11
3.3	Summary .....	11
	LIST OF REFERENCES .....	12
	LIST OF PREPARERS .....	17



# **APPENDIX B: ASSESSMENT OF RESEARCH REGARDING EMF AND HEALTH AND ENVIRONMENTAL EFFECTS**

## **1.0 Introduction**

Over the last 20 years, research has been conducted in the United States (U.S.) and around the world to examine whether exposures to electric and magnetic fields (EMF) at 50/60 hertz (Hz) from electric power lines are a cause of cancer, or adversely affect human health. The research included epidemiology studies that suggested a link with childhood for some types of exposures, as well as other epidemiology studies that did not; it also included lifetime animal studies, which showed no evidence of adverse health effects. Comprehensive reviews of the research conducted by governmental and scientific agencies in the U.S. and in the United Kingdom (UK) had examined the research, and did not find a basis for imposing additional restrictions (NIEHS, 1999; IEE, 2000).

The Bonneville Power Administration (BPA) requested that Exponent update the BPA on research on EMF and health and in relation to exposures that might occur near the Bethel-Santiam Transmission Project.

This update concentrates on recent major research studies to explain how they contribute to the assessment of effects of EMF on health (Section 2). The focus is on both epidemiologic and laboratory research, because these research approaches provide different and complementary information for determining whether an environmental exposure can affect human health. Section 3, Ecological Research, reviews studies of potential effects of EMF on plants and animals in the natural environment. No additional studies of environmental effects were found in our search of the scientific literature through May 2001.

## **2.0 Health**

### **2.1 The NIEHS Report and Research Program**

In 1998, the NIEHS completed a comprehensive review of the scientific research on health effects of EMF. The NIEHS had been managing a research program that Congress funded in 1996, in response to questions regarding exposure to EMF from power sources. The program was known as the RAPID Program (Research and Public Information Dissemination Program). The NIEHS convened a panel of scientists (the “Working Group”) to review and evaluate the RAPID Program research and other research. Their report, *Assessment of Health Effects from Exposure to Power-Line Frequency Electric and Magnetic Fields*, was completed in July 1998 (NIEHS, 1998).

The director of the NIEHS prepared a health risk assessment of EMF and submitted his report to Congress in June 1999 (NIEHS, 1999). Experts at NIEHS, who had considered the previous Working Group report, reports from four technical workshops, and research that became available after June 1998, concluded as follows:

The scientific evidence suggesting that ELF-EMF [extremely low frequency-electric and magnetic field] exposures pose any health risk is weak. The strongest evidence for health

effects comes from associations observed in human populations with two forms of cancer: childhood leukemia and chronic lymphocytic leukemia in occupationally exposed adults. . . . In contrast, the mechanistic studies and animal toxicology literature fail to demonstrate any consistent pattern . . . . No indication of increased leukemias in experimental animals has been observed. . . . The lack of consistent, positive findings in animal or mechanistic studies weakens the belief that this association is actually due to ELF-EMF, but it cannot completely discount the epidemiology findings. . . . The NIEHS does not believe that other cancers or other non-cancer health outcomes provide sufficient evidence of a risk to currently warrant concern (pp. 9-10).

Although the results of the RAPID research are described in some detail in the 1998 report, many of the studies had not been published in the peer-reviewed literature. Recognizing the need to have these results reviewed and considered for publication, the NIEHS arranged for a special edition of the journal *Radiation Research* (*Radiation Research*, 153(5), 2000) to be devoted to this topic.<sup>1</sup>

## **2.2 Update of Research Related to Cancer**

This update includes studies of residential or occupational exposures to EMF and leukemia that became available this year (2001), including several reports from the California Department of Health Services. That Department conducted a workshop in 1999 to discuss epidemiologic research on EMF and health. The reports presented at this workshop were published in January 2001 as a supplement to the journal, *Bioelectromagnetics*. Many of the papers were technical discussions of methodology issues in epidemiologic studies of EMF, including discussions of how better to understand the conflicting results reported in previous studies (Neutra and Del Pizzo, 2001). For example, one paper evaluated epidemiology studies to determine whether systematic errors occurred in selection of cases and controls, or measurement of exposure. Although such systematic errors, or bias, occurred in some studies, there was insufficient information to assess the effect on results (Wartenberg, 2001a). Other researchers discuss epidemiologic approaches to study how possible confounding factors, such as the age and type of home and traffic density, might affect the interpretation of studies of EMF and childhood cancer (Langholz, 2001; Reynolds et al., 2001).

For this update, we review papers from this workshop that provide new information or statistical analyses. Several of the studies are “meta-analyses,” an approach that incorporates statistical methods to analyze differences and aggregate the results of smaller studies. The section below includes a review of meta-analyses of the studies of childhood leukemia through 1999, and a meta-analysis of studies of breast cancer in adults (Erren, 2001).

### **2.2.1 Epidemiology Studies of Children**

The question of power lines and childhood cancer has been based on the assumption that the relevant exposure associated with power lines is the magnetic field, rather than the electric field. This assumption rests on the fact that electric fields are shielded from the interior of homes (where people spend the vast majority of their time) by walls and vegetation, while magnetic fields are not. The magnetic field in the vicinity of a power line results from the flow of current; higher currents result in higher levels of magnetic fields.

---

<sup>1</sup> See, for instance, the articles cited in the **List of References** under Balcer- Kubiczek, Boorman, Loberg, and Ryan.

Epidemiologic studies report results in the form of statistical associations. The term “statistical association” is used to describe the tendency of two things to be linked or to vary in the same way, such as level of exposure and occurrence of disease. However, statistical associations are not automatically an indication of cause and effect, because the interpretation of numerical information depends on the context, including (for example) the nature of what is being studied, the source of the data, how the data were collected, and the size of the study. The larger studies and more powerful studies of EMF have not reported convincing statistical associations between power lines and childhood leukemia (e.g., Linet et al., 1997; McBride et al., 1999; UKCCS, 1999). Despite the larger sample size, these studies usually had a limited number of cases exposed over 2 or 3 milligauss (mG).

### *Epidemiology studies*

The following discussion briefly describes major studies.

- A study from Germany included 502 children with leukemia and 1,289 control children (Schuz et al., 2001). Measurements of magnetic-field intensity (50 Hz) were taken for 24 hours in the child’s bedroom. The results were calculated for daytime or nighttime levels in the bedroom, rather than for the child’s overall 24-hour exposure. The authors report an association with leukemia for mean daytime magnetic-field exposures that might have been due to chance. They reported an association between mean nighttime magnetic-field levels and leukemia for the highest exposed group (4 mG or higher; 9 cases). The assessment of exposure by mean field levels in the bedroom did not link magnetic-field levels to any specific source. The authors note in their conclusions that “. . . fewer than one-third of all stronger magnetic fields were caused by high-voltage powerlines. . . .” (Schuz et al., 2001: 734).

Several aspects of the study detract from the validity of the results: the estimate included a broad margin of error because only a small number of cases was exposed at the higher levels, and many eligible cases and controls did not participate, which means that the responders may not represent the population and results could be biased. Another concern is that these magnetic field measurements were taken in 1997, long after the relevant exposure period for cases diagnosed in 1990-1994. Magnetic-field levels may have changed over time, as electricity usage changed.

- A study from British Columbia, Canada, included 462 children who had been diagnosed with leukemia and an equal number of children without leukemia for comparison (McBride et al., 1999). Magnetic-field exposure was assessed for each of the children in several ways: personal monitors were worn in a backpack for 48 hours, a monitor took measurements in the bedroom for 24 hours, the wiring outside the house was rated by potential exposure level (wire codes), and measurements were taken around the outside perimeter of the homes. (Wire codes are a method of estimating relative exposure intensity based on the configuration of the power lines.) Regardless of the method used to estimate magnetic-field exposure, the magnetic-field exposure of children who had leukemia was not greater than that of the children in the comparison group.
- A study conducted in Ontario, Canada reported on the magnetic-field exposure of a smaller group of children (Green et al., 1999a). No increased risk estimates were found with the average magnetic fields in the bedroom or the interior, or with any of the three methods of estimating exposure from wire-configuration codes. A still smaller group of 88 children with leukemia and their controls wore personal monitors to measure magnetic fields (Green et al., 1999b). Associations with magnetic fields were reported in some of the analyses, but most of the risk estimates had a broad margin of error, and major methodological problems in the study preclude any clear interpretation of the findings.



- The United Kingdom Childhood Cancer Study, the largest study to date, included a total of 1073 childhood leukemia cases (UKCCS, 1999). Exposure was assessed by spot measurements in the home (bedroom and family room) and school, and summarized by averaging these over time. No evidence was found to support the idea of an increased risk of leukemia from exposures to magnetic fields from power sources inside or outside of the home.
- The UKCCS investigators had obtained magnetic-field measurements on only a portion of the cases in their study (UKCCS, 1999). To obtain additional information, they used a method to assess exposure to magnetic fields without entering homes; they were thus able to analyze 50% more subjects (UKCCS, 2000). For all these children, they measured distances to power lines and substations. This information was used to calculate the magnetic field from these external field sources, based on power-line characteristics related to production of magnetic fields. The results of the second UKCCS study showed no evidence for an association with leukemia for magnetic fields calculated to be between 1 mG and 2 mG, 2 mG and 4 mG, or 4 mG or greater at the residence, in contrast to the weak association reported for measured fields of 4 mG or greater in the first report (UKCCS, 1999).

Researchers have proposed that the associations that are sometimes reported between childhood leukemia and power lines may be due to other factors that can confound the analysis. One example is heavy traffic, which may occur near power lines and can increase the levels of potentially carcinogenic chemicals in the area. Earlier studies had reported associations between traffic density and childhood cancer (Savitz et al., 1988). If power lines were more common in areas that had higher traffic density, then the increased air pollution might explain an association between power lines and childhood cancer. However, more recent studies seem to eliminate this possibility. In a study of 90 cases of childhood leukemia, Reynolds et al. (2001) found no evidence of an association with traffic density. In a larger study that included 986 cases of childhood leukemia, no association was found with high traffic-density exposure during pregnancy or childhood (Raaschou-Nielsen et al., 2001). In addition, no association with childhood leukemia or brain cancer was found for exposures to benzene or nitrogen dioxide. Associations were reported between Hodgkin's disease and exposure to each of these chemicals.

#### *Meta-analyses of studies of leukemia*

Recently, researchers reanalyzed the data from previous epidemiology studies of magnetic fields and childhood leukemia (Ahlbom et al., 2000; Greenland et al., 2000). The researchers pooled the data on individuals from each of the studies, creating a study with a larger number of subjects and therefore greater statistical power than any single study. A pooled analysis is preferable to other types of meta-analyses in which the results from several studies are combined from grouped data obtained from the published studies. These analyses focused on studies that assessed exposure to magnetic fields using 24-hour measurements or calculations based on the characteristics of the power lines and current load. Both Ahlbom et al. and Greenland et al. used exposure categories of <0.1 microtesla ( $\mu\text{T}$ ) (<1 mG) as a reference category. The statistical results of these analyses can be summarized as follows:

- The pooled analyses provided no indication that wire codes are more strongly associated with leukemia than measured fields.
- Pooling these data corroborates an absence of an association between childhood leukemia and magnetic fields for exposures below 0.3  $\mu\text{T}$  (3 mG).
- Pooling these data results in a statistical association with leukemia for exposures greater than 0.3 or 0.4  $\mu\text{T}$  (3-4 mG).

The authors are appropriately cautious in the interpretation of their analyses, and they clearly identify the limitations in their evaluation of the original studies. Magnetic fields above 0.3  $\mu$ T in residences are estimated to be rather rare, about 3% in the U.S. (Zaffanella, 1993). Limitations include sparse data (few cases) to adequately characterize a relationship between magnetic fields and leukemia, uncertainties related to pooling different magnetic-field measures without evidence that all of the measures are comparable, and incomplete and limited data on important confounders (other risk factors for disease that may distort the analysis) such as housing type and traffic density.

A meta-analysis of the data from epidemiologic studies of childhood leukemia studies was presented at the California Workshop and recently published (Wartenberg, 2001b). This meta-analysis did not have the advantage of obtaining and pooling the data on all of the individuals in the studies, unlike those published before it (Ahlbom et al., 2000; Greenland et al., 2000). Rather than individual data, Wartenberg (2001b) used an approach that extracted the published results, reported as grouped data from several published studies. He used 19 studies overall, after excluding 7 studies that had insufficient data on individuals or deficiencies in the exposure assessment data. He reported a weak association for a) “proximity to electrical facilities” based on wire codes or distance, and b) magnetic-field level over 2 mG, based on either calculations from wiring and loading characteristics (if available) or on spot magnetic-field measurements. The results show more cases than controls exposed to measured or calculated fields above 2 mG. The author concludes that the analysis supports an association, although the size of the effect is small to moderate, but also notes “limitations due to design, confounding, and other biases may suggest alternative interpretations” (Wartenberg, 2001b:S-100).

The results of this meta-analysis are not directly comparable to previous ones regarding fields of 3 or 4 mG because the analysis was not based on individual data. The comparison of grouped data used different exposure cut points for the analysis and different criteria for the comparison group. None of these three analyses (Ahlbom et al., 2000; Greenland et al., 2000; Wartenberg, 2001b) includes the results of the UK analysis of over 3000 cases based on calculated fields, which found no association between EMF and childhood cancer, regardless of the exposure level.

### **2.2.2 Epidemiology Studies of Adults**

Studies of adults with certain types of cancer, such as brain cancer, breast cancer, or leukemia, have reported associations with exposure to magnetic fields at residences, but results have not been consistent across studies. Contradictory results among studies argue against a conclusion that the association reflects a cause-and-effect relationship. In their assessments of risk, scientists give most weight to studies that include more people, obtain more detailed and individual exposure assessments, and/or include people who have higher exposures.

A study of 492 adult cases of brain cancer in California included measurements of magnetic fields taken in the home and at the front door, and considered the types of power-line wiring (Wrensch et al., 1999). The authors report no evidence of increased risk with higher exposures, no association with type of power line, and no link with levels measured at the front door.

A number of recent studies of breast cancer focused on electric blankets as a source of high exposure. Electric blankets are assumed to be one of the strongest sources of EMF exposure in the home. Three studies of electric blanket use found no evidence that long-term use increased the risk of breast cancer. Women who developed breast cancer reported no difference in total use of electric blankets, use in recent years, or use many years in the past:

- Gammon et al. (1998) reported that, even for those who kept the blanket on most of the time, no increase in risk was found for those who had longer duration of use (measured in months).

- A study of 608 breast cancer cases also found no evidence of increased use of electric blankets or other home appliances in cases compared to controls, and no indication of increasing risk with a longer time of use (Zheng et al., 2000).
- In a cohort of over 120,000 female nurses, data were obtained on known risk factors for breast cancer as well as electric-blanket use (Laden et al., 2000). For a large subset of this group, the questions about exposure were asked before the disease occurred, a step taken to eliminate bias in recalling exposure.

Erren (2001) reported the results of a meta-analysis of the studies of breast cancer, in which the results of 24 different studies in women were statistically aggregated. When the results of all 24 studies were pooled, including studies of workplace exposures, the estimate indicated an association between EMF and a small excess breast cancer risk. The pooled results for exposure to EMF in the vicinity of electrical facilities did not show an association with breast cancer, nor did the results for exposure to EMF from appliance use. However, the meta-analysis also showed a lack of consistency among the results of the individual studies, a broad variation in the designs, and a wide range of methods used to assess exposure. No adjustments were made to the data to give increased weight to studies based on more comprehensive exposure assessments. The author also noted that the weak statistical association might be an artifact (a result of chance or unforeseen error) rather than an indication of a cause-and-effect relationship (Erren, 2001).

### **2.2.3 Laboratory Studies of EMF**

Laboratory studies complement epidemiologic studies of people because the effects of heredity, diet, and other health-related exposures of animals can be better controlled or eliminated. The assessment of EMF and health, as for any other exposure, includes chronic, long-term studies in animals (*in vivo* studies) and studies of changes in genes or other cellular processes observed in isolated cells and tissues in the laboratory (*in vitro*).

Although the results of the RAPID Program were described in some detail in the NIEHS reports (NIEHS, 1998), many of the studies had not been published in the peer-reviewed literature. The RAPID research program included studies of four biological effects, each of which had been observed in only one laboratory. These effects are as follows: effects on gene expression, increased intracellular calcium in a human cell line, proliferation of cell colonies on agar, and increased activity of the enzyme ornithine decarboxylase (ODC). Some scientists have suggested that these biological responses are signs of possible adverse health effects of EMF. It is standard scientific procedure to attempt to replicate results in other laboratories, because artifacts and investigator error can occur in scientific investigations. Replications, often using more experiments or more rigorous protocols, help to ensure objectivity and validity. Attempts at replication can substantiate and strengthen an observation, or they may discover the underlying reason for the observed response.

Studies in the RAPID program reported no consistent biological effects of EMF exposure on gene expression, intracellular calcium concentration, growth of cell colonies on agar, or ODC activity (Boorman et al., 2000b). For example, Loberg et al. (2000) and Balcer-Kubiczek et al. (2000) studied the expression of hundreds of cancer-related genes in human mammary or leukemia cell lines. They found no increase in gene expression with increased intensity of magnetic fields. To test the experimental procedure, they used X-rays and treatments known to affect the genes. These are known as positive controls and, as expected, caused gene expression in exposed cells.

Scientists have concluded that the combined animal bioassay results provide no evidence that magnetic fields cause, enhance, or promote the development of leukemia and lymphoma, or mammary cancer (e.g., Boorman et al., 1999; McCormick et al., 1999; Boorman et al., 2000 a, b; Anderson et al., 2001).

#### **2.2.4 Summary Regarding Cancer**

Epidemiology studies do not support the idea that EMF from power lines increase the risk of cancers in adults. The latest epidemiologic studies of childhood cancer, considered in the context of the other data, provide no persuasive and consistent evidence that leukemia in children is causally associated with magnetic fields measured at the home, calculated based on distance and current loading, or with wire codes. Recent meta-analyses reported no association between childhood cancer and magnetic fields below 2 or 3 mG. Although some association was reported for fields above this level, fields at most residences are likely to be below 3 or 4 mG. The authors of each of these analyses list several biases and problems that render the data inconclusive, and prevent resolution of the inconsistencies in the epidemiologic data. For this reason, laboratory studies can provide important complementary information. Large, well-conducted animal studies provide no convincing evidence that exposure increases the risk of cancer. Animal studies, and studies of initiation and promotion, provide no basis to conclude that EMF increases leukemia, lymphoma, breast, brain, or any other type of cancer.

#### **2.3 Research Related to Reproduction**

Previous epidemiologic studies reported no association with birth weight or fetal growth retardation after exposure to sources of relatively strong magnetic fields, such as electric blankets, or sources of typically weaker magnetic fields such as power lines (Bracken et al., 1995; Belanger et al., 1998).

A recent epidemiology study examined miscarriages<sup>2</sup> in relation to exposures to magnetic fields from electric bed-heating (electric blankets, heated waterbeds and mattress pads), which result in higher exposures than residential fields in general (Lee et al., 2000). The researchers assessed exposure prior to the birth (a prospective study) and included information to control for potential confounding factors (other exposures and conditions that affect the risk of miscarriage). This study had a large number of cases and high participation rates. Miscarriage rates were lower among users of electric bed heating.

Studies of laboratory animals exposed to pure 60-Hz fields have shown no increase in birth defects, no multigenerational effects, and no changes that would indicate an increase in miscarriage or loss of fertility (e.g., Ryan et al., 1999; Ryan et al., 2000). Exposed and unexposed litters were no different in the amount of fetal loss and the number and type of birth defects, indicating no reproductive effect of EMF.

In summary, the recent evidence from epidemiology and laboratory studies provides no indication that exposure to power-frequency EMF has an adverse effect on reproduction, pregnancy, or growth and development of the embryo. The results of these recent studies are consistent with the conclusions of the NIEHS.

#### **2.4 Other Recent Reviews by Scientific Advisory Groups**

Reviews of the scientific research regarding EMF and health by Health Council of the Netherlands and the Institute of Electrical Engineers of the UK were published in 2000. The National Radiological

---

<sup>2</sup> The medical term for miscarriage is spontaneous abortion.

Protection Board of Great Britain (NRPB) Advisory Group on Non-Ionizing Radiation published the most recent review in 2001. This review includes research published in 2000, and includes the most comprehensive discussion of the individual research studies.

#### **2.4.1 National Radiological Protection Board of Great Britain (NRPB) Advisory Group on Non-Ionising Radiation**

The conclusions from the report prepared by the NRPB's Advisory Group on Non-Ionising Radiation (AGNIR) on extremely low frequency (ELF) EMF and the risk of cancer are consistent with previous reviews. Members from universities, medical schools, and cancer research institutes reviewed the reports of experimental and epidemiological studies, including reports in the literature in 2000. Their general conclusions are as follows:

Laboratory experiments have provided no good evidence that extremely low frequency electromagnetic fields are capable of producing cancer, nor do human epidemiological studies suggest that they cause cancer in general. There is, however, some epidemiological evidence that prolonged exposure to higher levels of power frequency magnetic fields is associated with a small risk of leukaemia in children. In practice, such levels of exposure are seldom encountered by the general public in the UK [or in the US] (NRPB, 2001: 164).

The group further recognizes that the scientific evidence suggesting that exposure to power-frequency electromagnetic fields poses an increased risk of cancer is very weak. Virtually all of the cellular, animal, and human laboratory evidence provides no support for an increased risk of cancer incidence following such exposure to power frequencies, although sporadic positive findings have been reported. In addition, the epidemiological evidence is, at best, weak.

These conclusions of the Advisory Group are consistent with previous reviews by the NIEHS (1999) and the Health Council of the Netherlands (HCN, 2000). The NRPB response to the Advisory Group report states "the review of experimental studies by [the Advisory Group] AGNIR gives no clear support for a causal relationship between exposure to ELF-EMFs and cancer" (NRPB, 2001:1).

#### **2.4.2 Health Council of the Netherlands**

The Health Council of the Netherlands has prepared an update of its 1992 Advisory Report on exposure to electromagnetic fields (0 Hz to 10 MHz) (HCN, 2000). Members of the Expert Committee prepared the report. The Expert Committee based its analysis on the review and summaries of the studies provided in the NIEHS (1998) and concurred with the views of the director of the NIEHS (1999). For the update, the Committee evaluated a number of publications that appeared after these reports, e.g., McBride et al. (1999) and Green et al. (1999a), and wrote:

The committee thinks that the quality of the relevant epidemiological research has improved considerably since the publication of the advisory report in 1992. Even so, this research has not resulted in unequivocal, scientifically reliable conclusions (p. 15).

The Council emphasizes that the associations with EMF reported in epidemiologic studies are strictly statistical and do not demonstrate a cause-and-effect relationship. In their view, experimental research does not demonstrate a causal link or a mechanism to explain EMF as a cause of disease in humans. They concluded that there is no reason to recommend measures to limit residence near overhead power lines (HCN, 2000).

### **2.4.3 Institution of Electrical Engineers (IEE) of Great Britain**

One of the recent reviews was that of the Institution of Electrical Engineers (IEE) of Great Britain (IEE, 2000). In 1992, the IEE set up a Working Party whose eight members, with broad expertise in the health sciences, review the relevant scientific literature and prepare reports of their views. Their conclusion is based on recent major epidemiologic studies and the scientific literature built up over the past 20 years. In May 2000, the Working Party concluded “. . . that there is still not convincing scientific evidence showing harmful effects of low level electromagnetic fields on humans” (IEE, 2000:1).

## **3.0 Ecological Research**

Scientists have studied the effects of high-voltage transmission lines on many plant and animal species in the natural environment. In this section, we briefly review the research on the effects of EMF on ecological systems to assess the likelihood of adverse impacts. In addition to the comprehensive review of research on this topic by wildlife biologists at the BPA (Lee et al., 1996), we searched the published scientific literature for more recent studies published between 1995 and May 2001.

### **3.1 Fauna**

The habitat on the transmission-line right-of-way and surrounding area shields most wildlife from electric fields. Vegetation in the form of grasses, shrubs, and small trees largely shields small ground-dwelling species such as mice, rabbits, foxes, and snakes from electric fields. Species that live underground, such as moles, woodchucks, and worms, are further shielded from electric fields by the soil. Hence, large species such as deer and domestic livestock (e.g., sheep and cattle) have greater potential exposures to electric fields since they can stand taller than surrounding vegetation. However, the duration of exposure for deer and other large animals is likely to be limited to foraging bouts or the time it takes them to cross under the line. Furthermore, all species would be exposed to higher magnetic fields under a transmission-line than elsewhere, as the vegetation and soil do not provide shielding from this aspect of the transmission-line electrical environment.

Field studies have been performed in which the behavior of large mammals in the vicinity of high-voltage transmission lines was monitored. No effects of electric or magnetic fields were evident in two studies from the northern United States on big game species, such as deer and elk, exposed to a 500-kV transmission line (Goodwin 1975; Picton et al., 1985). In such studies, a possible confounding factor is audible noise. Audible noise associated with high-voltage power transmission lines (with voltages greater than 110-kV) is due to corona. Audible noise generated by transmission lines reaches its highest levels in inclement weather (rain or snow).

Much larger populations of animals that might spend time near a transmission line are livestock that graze under or near transmission lines. To provide a more sensitive and reliable test for adverse effects than informal observation, scientists have studied animals continuously exposed to fields from the lines in relatively controlled conditions. For example, grazing animals such as cows and sheep have been exposed to high-voltage transmission lines and their reproductive performance examined (Lee et al., 1996). In some studies, the effects of exposure over one or more successive breedings were examined (Angell et al., 1990). Compared to unexposed animals in a similar environment, it was found that the exposure did not affect reproductive functions or pregnancy of cows (Algers and Hennichs, 1985; Algers and Hultgren, 1987).

A group of investigators from Oregon State University, Portland State University, and other academic centers evaluated the effects of long-term exposure to EMF from a 500-kV transmission line operated by

BPA on various cellular aspects of immune response, including the production of proteins by leukocytes (IL-1 and IL-2) of sheep. In previous unpublished reports, the researchers found differences in IL-1 activity between exposed and control groups. However, in their most recent replication, the authors found no evidence of differences in these measures of immune function. The sheep were exposed to 27 months of continuous exposure to EMF, a period of exposure much greater than the short, intermittent exposures of sheep grazing under transmission lines. Mean exposures of magnetic and electric fields were 3.5-3.8  $\mu$ T (35-38 mG) and 5.2-5.8 kV/m, respectively (Hefeneider et al., 2001).

Scientists from Illinois Institute of Technology (IIT) monitored the possible effects of electric and magnetic fields on fauna and flora in Michigan and Wisconsin from 1969 – 1997 to evaluate the effects of an above-ground, military-communications antenna operating at 76 Hz. The antenna produces EMF similar in physical characteristics to those produced by high-voltage transmission lines, but of much lower intensity. This study included embryonic development, fertility, postnatal growth, maturation, aerobic metabolism, and homing behavior, and showed no adverse impacts of ELF electric and magnetic fields on the animals (NRC, 1997).

The hormone melatonin, secreted at night by the pineal gland, plays a role in animals that are seasonal breeders. Studies in laboratory mice and rats have suggested that exposure to electric and/or magnetic fields might affect levels of the hormone melatonin, but results have not been consistent (Wilson et al., 1981; Holmberg, 1995; Kroeker et al., 1996; Vollrath et al., 1997; Huuskonen et al., 2001). However, when researchers examined sheep and cattle exposed to EMF from transmission lines exceeding 500-kV, they found no effect on the levels of the hormone melatonin in blood, weight gain, onset of puberty, or behavior in sheep and cattle (Stormshak et al., 1992; Lee et al., 1993; Lee et al., 1995; Thompson et al., 1995; Burchard et al., 1998).

Another part of the IIT study examined the effect of the antenna system fields on the growth, development, and homing behavior of birds. Studies of embryonic development (Beaver et al., 1993), fertility, postnatal growth, maturation, aerobic metabolism, and homing behavior showed no adverse impacts of ELF electric and magnetic fields on the animals (NRC, 1997). Fernie and colleagues studied the effects of continuous EMF exposure of raptors to an electric field of 10 kV/m in a controlled, laboratory setting. The exposure was designed to mimic exposure to a 765-kV transmission line. Continuous EMF exposure was found to reduce hatching success, yet increase egg size, fledging success, and embryonic development (Fernie et al., 2000). In a study of the effects on body mass and food intake of reproducing falcons, the authors found that EMF lengthened the photoperiod as a result of altered melatonin levels in the male species, yet concluded that “EMF effects on adult birds may only occur after continuous, extended exposure,” which is not likely to occur from resting on power lines (Fernie and Bird, 1999:620).

Several avian species are reported to use the earth’s magnetic field as one of the cues for navigation. It has been proposed that deposits of magnetite in specialized cells in the head are the mechanism by which the birds can detect variations in the inclination and intensity of a dc magnetic field (Kirschvink and Gould, 1981; Walcott et al., 1988). In early studies of transmission lines, it was reported that the migratory patterns of birds appeared to be altered near transmission lines (Southern, 1975; Larkin and Sutherland, 1977). However, these studies were of crude design, and Lee et al. (1996) concluded that, “During migration, birds must routinely fly over probably hundreds (or thousands) of electrical transmission and distribution lines. We are not aware of any evidence to suggest that such lines are disrupting migratory flights” (p. 4-59). No further studies on this topic were identified in the literature.

Bees, like birds, are able to detect the earth’s dc magnetic fields. They are known to use magnetite particles, which are contained in an abdominal organ, as a compass (Kirschvink and Gould, 1981). In the

laboratory, they are able to discriminate between a localized magnetic anomaly and a uniform background dc magnetic field (Walker et al., 1982; Kirschvink et al., 1992).

Greenberg et al. (1981) studied honeybee colonies placed near 765-kV transmission lines. They found that hives exposed to electric fields of 7 kV/m had decreased hive weight, abnormal amounts of propolis (a resinous material) at hive entrances, increased mortality and irritability, loss of the queen in some hives, and a decrease in the hive's overall survival compared to hives that were not exposed. Exposure to electric fields of 7-12 kV/m may induce a current or heat the interior of the hive; however, placing the hive farther from the line, shielding the hive, or using hives without metallic parts eliminates this problem. ITT studied the effects of EMF on bees exposed to the 76-Hz antenna system at lower intensities and concluded that these behavioral effects of "ELF-EMF impacts are absent or at most minimal" (NRC, 1997:102).

Reptiles and amphibians contribute to the overall functioning of the forest ecosystems. However, little research has been performed on the effects of EMF on reptiles and amphibians in their natural habitat.

### **3.2 Flora**

Numerous studies have been carried out to assess the effect of exposure of plants to transmission-line electric and magnetic fields. These studies have involved both forest species and agriculture crops. Researchers have found no adverse effects on plant responses, including seed germination, seedling emergence, seedling growth, leaf area per plant, flowering, seed production, germination of the seeds, longevity, and biomass production (Lee et al., 1996).

The only confirmed adverse effect of transmission lines on plants was reported for transmission lines with voltages above 1200-kV. For example, Douglas Fir trees planted within 15 m of the conductors were shorter than trees planted away from the line. Shorter trees are believed to result from corona-induced damage to the branch tips. Trees between 15 and 30 m away from the line suffered needle burns, but those 30 m and beyond were not affected (Rogers et al., 1984). These effects would not occur at the lower field intensities expected beyond the right-of-way of the proposed 500-kV transmission line.

### **3.3 Summary**

The habitat on the transmission-line rights-of-way and surrounding areas shield smaller animals from electric fields produced by high-voltage transmission lines; thus, vegetation easily shields small animals from electric fields. The greatest potential for larger animals to be exposed to EMF occurs when they are passing beneath the lines. Studies of animal reproductive performance, behavior, melatonin production, immune function, and navigation have found minimal or no effects of EMF. Past studies have found little effect of EMF on plants; no recent studies of plants growing near transmission lines have been performed. In summary, the literature published to date has shown little evidence of adverse effects of EMF from high-voltage transmission lines on wildlife and plants. At the field intensities associated with the proposed 230-kV transmission line, no adverse effects on wildlife or plants are expected.



## **LIST OF REFERENCES**

- Ahlbom, A.; Day, N.; Feychting, M.; Roman, E.; Skinner, J.; Dockerty, J.; Linet, M.; Michealis, J.; Olsen, J.H.; Tynes, T.; Verasalo, P.K. 2000. A pooled analysis of magnetic fields and childhood leukaemia. *British Journal of Cancer*, 83(5): 692-698.
- Algers, B.; and Hennichs, K. 1985. The effect of exposure to 400-kV transmission lines on the fertility of cows: a retrospective cohort study. *Preventive Veterinary Medicine* 3: 351-361.
- Algers, B.; and Hultgren, J. 1987. Effects of long-term exposure to a 400-kV, 50-Hz transmission line on estrous and fertility in cows. *Preventive Veterinary Medicine* 5: 21-36.
- Anderson, L.E.; Morris, J.E.; Miller, D.L.; Rafferty, C.N.; Ebi, K.L.; Sasser, L.B. 2001. Large granular lymphocytic (LGL) leukemia in rats exposed to intermittent 60 Hz magnetic fields. *Bioelectromagnetics*, 22:185-193.
- Angell, R.F.; Schott, M.R.; Raleigh, R.J.; Bracken, T.D. 1990. Effects of a high-voltage direct-current transmission line on beef cattle production. *Bioelectromagnetics*. 11(4):273-82.
- Balcer-Kubiczek, E.K.; Harrison, G.H.; Davis, C.C.; Haas, M.L.; Koffman, B.H. 2000. Expression analysis of human HL60 exposed to 60 Hz square or sine-wave magnetic fields. *Radiation Research*, 153(5): 670-678.
- Beaver, D.L.; Hill, R.W.; Lederle, P.E. 1993. Assessment of the effects of extremely low frequency electromagnetic radiation on growth and maturation in nestling tree swallows and deer mice. *Electricity and Magnetism in Biology and Medicine*. M. Blank, ed., San Francisco Press, Inc., pp. 925-926.
- Belanger, K.; Leaderer, B.; Hellenbrand, K.; Holford, T.R.; McSharry, J.; Power, M.E.; Bracken, M.B. 1998. Spontaneous abortion and exposure to electric blankets and heated water beds. *Epidemiology*, 9:36-42.
- Boorman, G.A.; Anderson, L.E.; Morris, J.E.; Sasser, L.B.; Mann, P.C.; Grumbein, S.L.; Hailey, J.R.; McNally, A.; Sills, R.C.; Haseman, J.K. 1999. Effects of 26-week magnetic field exposure in a DMBA initiation-promotion mammary glands model in Sprague-Dawley rats. *Carcinogenesis*, 20: 899-904.
- Boorman, G.A.; McCormick, D.J.; Ward, J.M.; Haseman, J.K.; Sills, R.C. 2000a. Magnetic fields and mammary cancer in rodents: A critical review and evaluation of published literature. *Radiation Research*, 153(5), Part 2: 617.
- Boorman, G.A.; Rafferty, C.N.; Ward, J.M.; Sills, R.C. 2000b. Leukemia and lymphoma incidence in rodents exposed to low-frequency magnetic fields. *Radiation Research*, 153(5), Part 2: 627.
- Bracken, M.B.; Belanger, K.; Hellenbrand, K.; Dlugosz, L.; Holford, T.R.; McSharry, J.E.; Adesso, K.; Leaderer, B. 1995. Exposure to electromagnetic fields during pregnancy with emphasis on electrically heated beds: association with birth weight and intrauterine growth retardation. *Epidemiology*, 6(3): 263-270.

- Burchard, J.F.; Nguyen, D.H.; Block, E. 1998. Effects of electric and magnetic fields on nocturnal melatonin concentrations in dairy cows. *J Dairy Sci.* 81(3):722-7.
- Erren, T.C. 2001. A meta-analysis of epidemiological studies of electric magnetic fields and breast cancer in women and men. *Bioelectromagnetics Supplement*, 5: S105-S119.
- Fernie, K.J.; and Bird, D.M. 1999. Effects of electromagnetic fields on body mass and food-intake of American kestrels. *The Condor.* 101:616-621.
- Fernie, K.J.; Bird, D.M.; Dawson, R.D.; Lague, P.C. 2000. Effects of electromagnetic fields on the reproductive success of American kestrels. *Physiol Biochem Zool.* 73(1):60-5.
- Gammon, M.D.; Schoenberg, J.B.; Britton, J.A.; Kelsey, J.L.; Stanford, J.L.; Malone, K.E.; Coates, R.J.; Brogan, D.J.; Potischman, N.; Swanson, C.A.; Brinton, L.A. 1998. Electric blanket use and breast cancer risk among younger women. *American Journal of Epidemiology*, 148: 556-63.
- Goodwin Jr., J.G. 1975. Big game movement near a 500-kV transmission line in northern Idaho. Bonneville Power Administration, Engineering and Construction Division, Portland, OR, June 27.
- Green, L.M.; Miller, A.B.; Villeneuve, P.J.; Agnew, D.A.; Greenberg, M.L.; Li, J.H.; Donnelly, K.E. 1999a. A case control study of childhood leukemia in southern Ontario, Canada, and exposure to magnetic fields in residences. *International Journal of Cancer*, 82:161-170.
- Green, L.M.; Miller, A.B.; Agnew, D.A.; Greenberg, M.L.; Li, J.H.; Villeneuve, P.J.; Tibshirani, R. 1999b. Childhood leukemia and personal monitoring of residential exposures to electric and magnetic fields in Ontario, Canada. *Cancer Causes and Control*, 10: 233-243.
- Greenberg, B.; Bindokas, V.P.; Frazier, M.J.; Gauger, J.R. 1981. Response of honey bees, *apis mellifera L.*, to high-voltage transmission lines. *Environmental Entomology*, 10: 600-610.
- Greenland, S.; Sheppard, A.; Kelsh, M.; Kuane, W.; Poole, C.; Kelsh, M.A. 2000. Childhood leukemia and power frequency magnetic fields: analysis from pooled data of thirteen epidemiologic studies. *Epidemiology*, 11: 624-634.
- HCN (Health Council of the Netherlands). 2000. Report on Exposure to Electromagnetic Fields (0 Hz – 10 MHz). No. 2000/06E.
- Hefeneider, S.H.; McCoy, S.L.; Hausman, F.A.; Christensen, H.L.; Takahashi, D.; Perrin, N.; Bracken, T.D.; Shin, K.Y.; Hall, A.S. 2001. Long-term effects of 60-Hz electric vs. magnetic fields on IL-1 and IL-2 activity in sheep. *Bioelectromagnetics*, 22(3):170-177.
- Holmberg, B. 1995. Magnetic fields and cancer: animal and cellular evidence—an overview. *Environ Health Perspect.* 103 Suppl 2:63-7.
- Huuskonen, H.; Saastamoinen, V.; Komulainen, H.; Laitinen, J.; Juutilainen, J. 2001. Effects of low-frequency magnetic fields on implantation in rats. *Reprod Toxicol*, 15(1):49-59.
- IEE (Institution of Electrical Engineers), Biological Effects Working Party. May 2000. The possible harmful biological effects of low level electromagnetic fields of frequencies up to 300 GHz. IEE Position Statement.

- Kirschvink, J.L.; and Gould, J.L. 1981. Biogenic magnetite as a basis for magnetic field detection in animals. *Biosystems*, 13(3):181-201.
- Kirschvink, J.L.; Diaz Ricci, J.; Nesson, M.H.; Kirschvink, S.J. 1992. Magnetite-based magnetoreceptors in animals: structural, behavioral, and biophysical studies. Electric Power Research Institute (EPRI), Report No. TR-102008, Palo Alto, CA. September.
- Kroeker, G.; Parkinson, D.; Vriend, J.; Peeling, J. 1996. Neurochemical effects of static magnetic field exposure. *Surg Neurol*, 45(1):62-6.
- Laden, F.; Neas, L.M.; Tolbert, P.E.; Holmes, M.D.; Hankinson, S.E.; Spiegelman, D.; Speizer, F.E.; Hunter, D.J. 2000. Electric blanket use and breast cancer in the nurses' health study. *American Journal of Epidemiology*, 152(1): 41-49.
- Langholz, B. 2001. Factors that explain the power line configuration wiring code - childhood leukemia association: what would they look like? *Bioelectromagnetics Supplements*, 5: S19-S31.
- Larkin, R.P., and Sutherland, P.J. 1977. Migrating birds respond to Project Seafarer's electromagnetic field. *Science*, 195(4280): 777-9 1977, Feb 25.
- Lee, G.M.; Neutra, R.R.; Hristova, L.; Yost, M.; Hiatt, R.A. 2000. The use of electric bed heaters and the risk of clinically recognized spontaneous abortion. *Epidemiology*, 11: 406-415.
- Lee, J., Stormshak, F., Thompson, J., Thinesen, P., Painter, L., Olenchek, B., Hess, D., Forbes, R. 1993. Melatonin secretion and puberty in female lambs exposed to environmental electric and magnetic fields. *Biol Reprod* 49(4):857-64
- Lee, J.M. BPA Biological Studies Task Team. 1996. Electrical and biological effects of transmission lines: a review. Bonneville Power Administration, Portland, Oregon, December.
- Lee, J.M., Stormshak, F., Thompson, J., Hess, D.L., Foster, D.L. 1995. Melatonin and puberty in female lambs exposed to EMF: a replicate study. *Bioelectromagnetics*, 16(2):119-23
- Linnet, M.S.; Hatch E.H.; Kleinerman, R.A.; Robinson, L.L.; Kaune, W.T.; Friedman, D.R.; Seversch, R.K.; Haines, C.M.; Hartsock, C.T.; Niwa, S.; Wacholder, S.; Tarone, R.E. 1997. Residential exposure to magnetic fields and acute lymphoblastic leukemia in children. *New England Journal of Medicine*, 337: 1-7.
- Loberg, L.I.; Engdahl, W.R.; Gauger, J.R.; McCormick, D.L. 2000. Expression of cancer-related genes in human cells exposed to 60 Hz magnetic fields. *Radiation Research*, 153(5): 679-684.
- McBride, M.L.; and Gallagher, RP; Theriault, G; Armstrong, BG; Tamaro, S; Spinelli, JJ; Deadman, JE; Fincham, S; Robinson, D; Choi, W. 1999. Power-frequency electric and magnetic fields and risk of childhood leukemia in Canada. *American Journal of Epidemiology*, 149:831-842.
- McCormick, D.L.; Boorman, G.A.; Findlay, J.C.; Hailey, J.R.; Johnson, T.R.; Gauger, J.R.; Pletcher, J.M.; Sill, R.C.; Haseman, J.K. 1999. Chronic toxicity/oncogenicity evaluation of 60 Hz (power frequency) magnetic fields in B6C3F mice. *Toxicologic Pathology*, 27:279-285.

- Neutra, R.R., and Del Pizzo, V. 2001. A richer conceptualization of "exposure" for epidemiological studies of the "EMF mixture". *Bioelectromagnetics Supplements*, 5: S48-S57.
- NIEHS (National Institute of Environmental Health Sciences). 1998. Assessment of Health Effects from Exposure to Power-Line Frequency Electric and Magnetic Fields: Working Group Report. NIH Publication No. 98-3981. Research Triangle Park, NC: National Institute of Environmental Health Sciences of the U.S. National Institutes of Health.
- NIEHS (National Institute of Environmental Health). 1999. Health effects from exposure to power line frequency electric and magnetic fields. NIH; National Institute of Health; NIH No. 99-4493; Research Triangle Park, NC.
- NRC (National Research Council). 1997. An evaluation of the U.S. Navy's extremely low frequency communications system ecological monitoring program. National Academy Press, Washington, D.C.
- NRPB (National Radiological Protection Board). 2001. Response statement of the NRPB: ELF electromagnetic fields and the risk of cancer. National Radiological Protection Board, Chilton, Didcot, Oxon, Volume 12, No.1, ISBN 0-859951-456-0.
- Picton, H.D., Canfield, J.E., Nelson, G.P. 1985. The impact of a 500-kV transmission line upon the North Boulder Winter Elk Range. US Forest Service Contract 53-0398-30E-3.
- Raaschou-Nielsen, O.; Hertel, O.; Thomsen, B.L.; Olsen, J.H. 2001. Air pollution from traffic at the residence of children with cancer. *American Journal of Epidemiology*, 153(5): 433-43.
- Radiation Research*. 2000. (Special Edition Updating RAPID results.) 153(5): 637-641. *See entries under Balcer-Kubiczek, Boorman, Loberg, and Ryan.*
- Reynolds, P.; Elkin, E.; Scalf, R.; Von Behren, J.; Neutra, R.R. 2001. A case-control pilot study of traffic exposures and early childhood leukemia using a geographic information system. *Bioelectromagnetics Supplements*, 5:S58-S6.
- Rogers, L.E., Beedlow, P.A., Carlile, D.W., Ganok, K.A., Lee, J.M. 1984. Environmental studies of a 1100-kV prototype transmission line: an annual report for the 1984 study period. Prepared by Battelle Pacific Northwest Laboratories for Bonneville Power Administration, Portland, Oregon.
- Ryan, B.M.; Symanski, R.R.; Pomeranz, L.E.; Johnson, T.R.; Gauger, J.R.; McCormick, D.L. 1999. Multi-generation reproduction toxicity assessment of 60-Hz magnetic fields using a continuous breeding protocol in rats. *Teratology*, 59(3): 156-62.
- Ryan, B.M.; Polen, M.; Gauger, J.R.; Mallett, E.; Kerns, M.B.; Bryan, T.L.; McCormick, D.L. 2000. Evaluation of the developmental toxicity in Sprague-Dawley rats. *Radiation Research*, 153(5): 637-641.
- Savitz, D.A., Wachtel, H., Barnes, F.A., John, E.M. & Tvrdik, J.G. 1988. Case-control study of childhood cancer and exposure to 60 Hz magnetic fields. *American Journal of Epidemiology*, 128, 21-38.
- Schuz, J.; Grigat, J.P.; Brinkmann, K.; Michaelis, J. 2001. Residential magnetic fields as a risk factor for childhood acute leukaemia: results from a German population-based case-control study. *International Journal of Cancer*, 91(5): 728-735. January 2.

- Southern, W.E. 1975. Orientation of gull chicks exposed to project Sanguine's electromagnetic field. *Science*, 189: 143-144.
- Stormshak, F., Bracken, T.D., Carey, M., Chartier, V., Dickson, L., Forbes, R., Hall, A., Havens, P., Hess, D., Krippaehne, S., Lee, J., Ogden, B., Olenchek, B., Painter, L., Rowe, K., Stearns, R., Thinesen, P., Thompson, J. 1992. Joint HVAC transmission EMF environmental study: final report on experiment 1. Bonneville Power Administration, Contract # DE-B179-90BPO4293, Portland, OR, May.
- Thompson, J.M.; Stormshak, F.; Lee, J.M.; Hess, D.; Painter, L. 1995. Cortisol secretion and growth in ewe lambs chronically exposed to electric and magnetic fields of a 60-Hertz 500-kilovolt AC transmission line. *J Animal Sci*, 73(11):3274-80
- UKCCS (United Kingdom Childhood Cancer Study Investigators). 1999. Exposure to power frequency magnetic fields and the risk of childhood cancer. *The Lancet*, 353(9194): 1925-31.
- UKCCS (United Kingdom Childhood Cancer Study Investigators). 2000. Childhood cancer and residential proximity to power lines. *British Journal of Cancer*, 83:1573-80.
- Vollrath, L.; Spessert, R.; Kratzsch, T.; Keiner, M.; Hollmann H. 1997. No short-term effects of high-frequency electromagnetic fields on the mammalian pineal gland. *Bioelectromagnetics*, 18(5):376-87.
- Walcott, C.; Gould, J.L.; Lednor, A.J. 1988. Homing of magnetized and demagnetized pigeons. *J Exp Biol*, 134:27-41.
- Walker, C.E.; Seitelman, D.L.; McElhaney, J.H.; Mullen, S.P.; Hagadorn, B.; Seto, Y.J. 1982. Effects of high-intensity 60-Hz fields on bone growth. *Journal of Bioelectricity*, 1(3):339-349.
- Wartenberg, D. 2001a. The potential impact of bias in studies of residential exposure to magnetic fields and childhood leukemia. *Bioelectromagnetics Supplements*, 5: S32-S47.
- Wartenberg, D. 2001b. Residential EMF exposure and childhood leukemia: Meta-analysis and population attributable risk. *Bioelectromagnetics Supplements*, 5: S86-S104.
- Wilson, B.W.; Anderson, L.E.; Hilton, D.I.; Phillips, RD. 1981. Chronic exposure to 60-Hz electric fields: effects on pineal function in the rat. *Bioelectromagnetics*, 2(4):371-80.
- Wrensch, M.; Yost, M.; Miike, R.; Lee, G.; Touchstone, J. 1999. Adult glioma in relation to residential power frequency electromagnetic field exposures in the San Francisco Bay Area. *Epidemiology*, 10: 523-527.
- Zaffanella, L.E. 1993. Survey of residential magnetic field sources. Vol. 1: Goals, results, and conclusions. (EPRI TR-102759-V1, Project 3335-02). Electric Power Research Institute, Palo Alto, CA.
- Zheng, T.Z.; Holford, T.R.; Mayne, S.T.; Owens, P.H.; Zhang, B.; Boyle, P.; Carter, D.; Ward, Y.W.; Zahm, S.H. 2000. Exposure to electromagnetic fields from use of electric blankets and other in-home electrical appliances and breast cancer risk. *American Journal of Epidemiology*, 151(11): 1103-11.

## LIST OF PREPARERS

**Linda S. Erdreich, Ph.D.**, is a Managing Scientist in the Health Group at Exponent. She received her Ph.D. in Epidemiology and an M.S. in Biostatistics and Epidemiology from The University of Oklahoma Health Sciences Center. Dr. Erdreich is an epidemiologist with specific expertise in biological and health research related to non-ionizing radiation, both radiofrequency and power-frequency fields. Formerly, she was Acting Section Chief and Group Leader of the Methods Evaluation and Development Staff at the U.S. Environmental Protection Agency (EPA) and Senior Epidemiologist of the Environmental Criteria and Assessment Office at the EPA. While at the EPA, she developed methods in quantitative health risk assessment, coordinated the drafting of federal guidelines, and participated in science policy decisions. Both in government and private industry, she has provided rigorous evaluations of the impact on public health or occupational health of a variety of chemicals, therapeutic drugs, and physical agents, including electric and magnetic fields. As a member of the Institute of Electrical and Electronics Engineers (IEEE) Standards Coordinating Committees on Non-Ionizing Radiation, Dr. Erdreich is chairman of a working group to evaluate epidemiologic data on radiofrequency exposures (3 kHz–300 GHz). She has been appointed as a member of the Committee on Man and Radiation (COMAR) of the IEEE's *Engineering in Biology and Medicine Society*. Dr. Erdreich serves as Adjunct Associate Professor at the University of Medicine & Dentistry of New Jersey.

**William H. Bailey, Ph.D.**, is a Principal Scientist and manages the Health Group scientists in Exponent's New York office. Before joining Exponent, Dr. Bailey was President of Bailey Research Associates, Inc., the oldest research and consulting firm with specialized expertise in electro-magnetic fields and health. Dr. Bailey specializes in applying state-of-the-art assessment methods to environmental health and impact issues. His 30 years of training and experience include laboratory and epidemiologic research, health risk assessment, and comprehensive exposure analysis. Dr. Bailey is particularly well known for his research on potential health effects of electromagnetic fields and is active in setting IEEE standards for human exposure to electromagnetic fields. He uses advanced analytical and statistical methods in the design and analysis of both experimental studies and epidemiology and survey research studies. In addition, Dr. Bailey's postgraduate training in the social, economic, and behavioral sciences is helpful in assessing the important effects of social, economic, and community factors on health risks and vulnerability to environmental impacts in health and environmental justice research. He is a member of a working group that advises a committee of the World Health Organization on risk assessment, perception, and communication. Dr. Bailey is also a visiting scientist at the Cornell University Medical College. He was formerly Head of the Laboratory of Neuropharmacology and Environmental Toxicology at the New York State Institute for Basic Research, Staten Island, New York, and an Assistant Professor and NIH postdoctoral fellow in Neurochemistry at The Rockefeller University in New York.

**Maria DeJoseph, M.S.**, is an Epidemiologist in Exponent's Health Group and is based in New York, New York. Ms. DeJoseph has a background in epidemiology and biological sciences. She served as the primary investigator for a case-control epidemiologic study of her design to investigate a mediastinitis outbreak in cardiothoracic surgery patients. Ms. De Joseph also has recruited and interviewed subjects, and analyzed hormone levels for an epidemiologic breast cancer study. She has conducted phytochemical analyses of medicinal plants, including the isolation and fractionation of tropical plants used medicinally by indigenous peoples and primates of Central and South America. Ms. DeJoseph has served as an ethnobotanical and zoopharmacological field researcher in Mexico, Costa Rica and Venezuela. She has used a variety of methods to identify chemical and prospective pharmaceutical compounds, including HPLC, column chromatography, anti-microbial assays, gas chromatography mass spectrometry (GC-MS), and nuclear magnetic resonance spectroscopy (NMR). Before joining exponent, Ms. DeJoseph was a Research Assistant in the Medical School, Division of Epidemiology at Stanford University.

*This page intentionally left blank.*

## 5.0 Persons and Agencies Consulted

### 5.1 Federal Agencies

United States Fish and Wildlife Service  
National Marine Fisheries Service  
United States Army Corps of Engineers

### 5.2 State Agencies

Oregon State Office of Archaeology and Historic Preservation  
Oregon Department of Fish and Wildlife  
Oregon Department of Environmental Quality  
Oregon Division of State Lands  
Oregon Department of Land Conservation and State Lands  
Energy Facility Siting Council, Oregon Department of Energy  
Oregon Department of Transportation

### 5.3 Local Agencies

Linn County Planning and Building Department  
Marion County Planning and Building Department  
Marion County Department of Community Development

### 5.4 Tribes

Confederated Tribes of Grand Ronde

### 5.5 Utilities

Portland General Electric

### 5.6 Landowners

There are approximately 100 landowners on the mailing list.





## 6.0 References

- Applied Archaeological Research. May 22, 2001. Results of a Cultural Resources Survey of the Bonneville Power Administration's Santiam-Bethel Tap Transmission Line Project, Marion County, Oregon. (Applied Archaeological Research Report No. 181) Portland, OR. Prepared for Bonneville Power Administration, Portland, OR.
- Bonneville Power Administration. 2000. Transmission system vegetation management program. Final environmental impact statement. DOE/EIS-0285. Portland, OR.
- Bracken, T. Dan. June 2001. Santiam-Bethel Transmission Project, *Appendix A, Electrical Effects*.
- Cowardin, L. M., V. Carter, F. C. Golet, and E. T. LaRoe. 1979. Classification of wetlands and deep water habitats of the United States. (FWS/OBS-79/31.) U.S. Fish and Wildlife Service. Washington, DC.
- Fennimore, Joe. June 8, 2001. Associate Planner, Marion County Community Development Department. Telephone conversation..
- Hopkins, S. Planner. May 1, 2001. Linn County Planning Department, OR. Telephone conversation.
- Hunt, W. April 30, 2001. Assistant district fish biologist. Oregon Department of Fish and Wildlife, Corvallis, OR. Telephone conversation.
- Jones & Stokes. May 17, 2001. Upgrade to the Bonneville Power Administration Santiam to Bethel, Oregon transmission line. Draft biological assessment. (J&S 0P008.01.) Bellevue, WA. Prepared for Bonneville Power Administration, Portland, OR.
- Linn County, Oregon. 2000. Linn County parks. Available: <<http://www.co.linn.or.us/>>. Accessed May 8, 2001.
- \_\_\_\_\_. 2001. Recreational facilities. Available: <<http://www.co.linn.or.us/>>. Accessed April 20, 2001.
- Marion County, Oregon. 2001. Recreational facilities. Available: <<http://www.co.marion.or.us>>. Accessed April 20, 2001.
- Maser, C. 1998. Mammals of the Pacific Northwest: from the coast to the high Cascades. Oregon State University Press. Corvallis, OR.
- McMaster, K. State Supervisor, USFWS Oregon State Office, Portland, OR. October 27, 2000 – letter to Leslie Kelleher of Bonneville Power Authority.
- Mitsch, W.J., and J.G. Gosselink. 1993. Wetlands. International Thomson Publishing. New York, NY.
- ODFW (Oregon Department of Fish and Wildlife). 1993. Oregon wildlife diversity plan. Portland, OR.

- ODFW. 1997. Oregon Department of Fish and Wildlife guidelines and criteria for stream-road crossings. Portland, OR.
- Oregon Department of Environmental Quality. 1998a. Map of 303(d) listed waterbodies and sub basin priorities. Available: <<http://waterquality.deq.state.or.us/WQLData/303dListMap.htm>>. Accessed April 26, 2001.
- Oregon Department of Environmental Quality. 1998b. Final 1998 303(d) file download page. Available: <<http://waterquality.deq.state.or.us/wq/303dlist/Download303d.htm>>. Accessed. April 26, 2001.
- Oregon Labor Market Information System. 2001. Oregon Employment Department unemployment and poverty statistics. Available: <<http://www.olmis.org>>. Accessed April 16, 2001.
- Oregon Natural Heritage Program. 2001. Natural Heritage database. Portland, OR.
- Oregon State University. 1997a. Oregon agriculture census, Linn County, 1997. Available: <<http://govinfo.library.orst.edu/cgi-bin/ag-list?01-043.orc>>. Accessed May 10, 2001.
- \_\_\_\_\_. 1997b. Oregon agriculture census, Linn County, 1997. Available: <<http://govinfo.library.orst.edu/cgi-bin/ag-list?28-043.orc>>. Accessed May 10, 2001.
- \_\_\_\_\_. 1997c. Oregon agriculture census, Marion County, 1997. Available: <<http://govinfo.library.orst.edu/cgi-bin/ag-list?01-047.orc>>. Accessed May 10, 2001.
- \_\_\_\_\_. 1997d. Oregon agriculture census, Marion County, 1997. Available: <<http://govinfo.library.orst.edu/cgi-bin/ag-list?28-047.orc>>. Accessed May 10, 2001.
- Oregon State University, Agricultural Extension. 1999. Oregon State University Extension agricultural statistics, Linn County, last updated April 23, 2001. Available: <<http://oregonstate.edu/extension/linn/Agstats1.html>>. Accessed May 10, 2001.
- Oregon State University, Extension Economic Information Office. 1999. Marion County agricultural commodity sales, 1999 (preliminary), last updated April 18, 2000. Available: <<http://www.open.org/~mcboc/agsales.htm>>. Accessed May 10, 2001.
- Portland State University Population Research Center. 2000. Population, ethnic, gender, and age distribution. Available: <<http://www.upa.pdx.edu/CPRC/>>. Accessed April 11, 2001.
- Salem OnLine. 2000. Salem OnLine. Available: <<http://www.salemlodging.com/index.html>>. Accessed May 8, 2001.
- U.S. Bureau of the Census. 1997. 1997 Model-based income and unemployment estimates. Available: <<http://www.census.gov>>. Accessed April 10, 2001.
- \_\_\_\_\_. 2000. 1999 unemployment rates. Available: <<http://www.census.gov>>. Accessed April 10, 2001.
- U.S. Bureau of Economic Analysis. 1998. Regional accounts data, employment sectors, annual earnings by industry sector, income and unemployment. Available: <<http://www.bea.doc.gov/bea/regional/reis/ca05>>. Accessed April 18, 2001.

USFWS (U.S. Fish and Wildlife Service). 1986. Recovery plan for the Pacific bald eagle. USDI Fish and Wildlife Service, Portland, OR.

USGS. 2000a. Groundwater atlas of the United States: Idaho, Oregon, and Washington. HA730-H. Available: <[http://capp.water.usgs.gov/gwa/ch\\_h/jpeg/H083.jpeg](http://capp.water.usgs.gov/gwa/ch_h/jpeg/H083.jpeg)>. Accessed April 30, 2001.

\_\_\_\_\_. 2000b. 1990 water use. Available: <<http://water.usgs.gov>>. Accessed April 30, 2001.

Wheeldon, Robert. June 6, 2001. Associate Planner, Linn County Planning and Building Department. Telephone conversation.



## 7.0 Glossary and Acronyms

### Acronyms

A	Ampere
BPA	Bonneville Power Administration
CWA	Clean Water Act
DLC	Donation Land Claim
EFH	Essential Fish Habitat
EMF	Electric and magnetic fields
EMI	Electromagnetic Interference
EPA	Environmental Protection Agency
ESU	Evolutionarily Significant Unit
FAA	Federal Aviation Administration
FCC	Federal Communication Commission
FEMA	Federal Emergency Management Agency
NAS	National Academy of Sciences
NEPA	National Environmental Policy Act
NESC	National Electrical Safety Code
NIEHS	National Institute of Environmental Health Sciences
NPDES	National Pollutant Discharge Elimination System
NRC	National Research Council
NWI	National Wetland Inventory
ODFW	Oregon Department of Fish and Wildlife
PEM	Palustrine emergent
PGE	Portland General Electric
PFO	Palustrine forested
PSS	Palustrine scrub-shrub
RI	Radio Interference
ROW	Right-of-way

SWPP	Stormwater Pollution Prevention
TVI	Television Interference
USFWS	U.S. Fish and Wildlife Service
USGS	U.S. Geological Service

### **Technical Terms**

Anadromous	Refers to fish such as salmon that hatch and rear in fresh water, move to the ocean to mature, and then return to fresh water to reproduce.
Alluvium	Material such as sand, silt, or clay that has been deposited on land by running water of streams and rivers.
Arcing	The process of current flowing across a gap, such as fault current flowing across an insulator string that flashed over due to a lightening strike.
Biological Assessment	A document required by the Endangered Species Act, which requires an evaluation of potential effects on listed species and critical habitat prior to implementing a proposed action. A proposed action is defined as any activity authorized, funded or carried out by a federal agency.
Blackouts	The disconnection of the source of electricity from all the electrical loads in a certain geographical area. Brought about by an emergency forced outage or other fault in the generation, transmission or distribution system serving the area.
Capacity	A measure of the ability of the transmission line to carry electricity.
Circuit	A system of conductors through which an electric current is intended to flow.
Conductor	Any metallic material, usually in the form of wire, cable, or bar, suitable for carrying an electrical current.
Corona	The phenomenon whereby the electric field associated with a power line cause ionization (molecular breakdown) of surrounding air, thus creating a high-frequency noise. This noise can be heard as static over an automobile radio when travelling under the power line.
Danger tree	Trees that pose a danger or hazard to the transmission line.
Double-circuit line	To place two separate electrical circuits on the same transmission structures or poles. Each circuit contains three separate conductors or bundles of conductors.

Floodplain	That portion of a river valley adjacent to the stream channel which is covered with water when the stream overflows its banks during flood stage.
Lattice steel	Refers to transmission towers constructed of multiple steel members that are connected together (usually in triangular shapes) to make up a frame.
Load	The amount of electric energy delivered or required at any specific point or points on a system. Load originates primarily at the energy using equipment of consumers, such as heaters, air conditioners, lights and motors. At BPA, load includes delivery to direct service industries (Note: Load is slightly larger than metered energy because of normal transmission and distribution losses in delivery from generator to consumer). Because loads are used to determine resource requirements, forecasts of electricity use are converted to loads.
Median	The middle number in a given sequence of numbers.
Mitigation	Steps taken to remove or lessen the effects predicted for each resource, as potentially caused by the transmission project. They may include reducing the impact, compensating for the impact, or avoiding it entirely. Some measures, such as adjusting the location of the towers to avoid a particular resource, are taken during the study and location process. Others, such as reseeding access roads, and/or avoiding the proliferation of weeds, are taken following project completion.
National Electrical Safety Code (NESC)	Written standards for the design, construction, maintenance and operation of electric supply and communication lines, equipment, and supply station in order to safeguard persons from hazards associated with those activities.
National Environmental Policy Act (NEPA)	A 1969 federal law that required evaluation of the environmental impact of federally funded projects and programs.
Noxious weeds	Plants that are injurious to public health, crops, livestock, land, or other property.
Outage	An event, caused by a disturbance on the electrical system, that requires BPA to remove a piece of equipment or a section of line from service. The disturbance can be either natural or caused by humans.
Overload	When too much current flows through transmission facilities that could cause damage or overheating. In the event of overloading, equipment has safeguards to disconnect it from the flow of electricity.



Palustrine emergent wetland	A shallow freshwater wetland characterized by erect, rotted, herbaceous hydrophytes (water loving plants).
Palustrine forested wetland	A wetland characterized by woody vegetation that is 20 feet or more in height.
Palustrine scrub-shrub wetland	A wetland dominated by woody vegetation less than 20 feet tall. This vegetation includes true shrubs, young trees, and trees and shrubs that are small or stunted because of environmental conditions.
Peak load	The maximum electrical load or the maximum average load during a designated interval such as 15 minutes.
Per capita	Per person
Reliability	The measure of the ability of a power system to provide uninterrupted service, even while that system is under stress.
Right-of-way (ROW)	An easement for a certain purpose over the land of another, such as a strip of land, electric transmission line ditch or pipeline. BPA usually acquires easements for its transmission lines, roads and other facilities such as guys and anchors.
Single-circuit	One electrical circuit consisting of three separate conductors or three bundles of conductors.
Substation	A non-generating electrical power station that serves to transform voltages to higher or lower levels, and that serves as a delivery point to individual customers such as utilities or large industrial plants. The BPA system has more than 400 substations.
Tap	A short transmission line that connects a substation to an existing transmission line.
Transmission grid	An interconnected network of transmission lines and associated equipment for the bulk transfer of electric energy between points of supply and demand. The BPA transmission grid includes some 22,500 circuit kilometers (14,00 circuit miles) of lines connecting more than 400 substations in the Pacific Northwest. The main grid consists of 230-kV, 345-kV, and 500-kV transmission lines.
Transmission line	A high-voltage power line used to carry electric power efficiently over long distances.
Voltage	The driving force that cause a current to flow in an electric circuit. Voltage and volt are often used interchangeably.
Wetlands	An area where the soil experiences anaerobic conditions because of inundation of water during part of any given year. Indicators of a wetland include types of plants, soil characteristics and hydrology.



**SANTIAM - BETHEL TRANSMISSION PROJECT**

**APPENDIX A**  
**ELECTRICAL EFFECTS**

June 2001

Prepared by  
**T. Dan Bracken, Inc.**

for  
**Bonneville Power Administration**



## Table of Contents

<b>1.0</b>	<b>Introduction</b> .....	<b>1</b>
<b>2.0</b>	<b>Physical Description</b> .....	<b>3</b>
2.1	Proposed Line.....	3
2.2	Existing Lines.....	3
<b>3.0</b>	<b>Electric Field</b> .....	<b>3</b>
3.1	Basic Concepts.....	3
3.2	Transmission-line Electric Fields.....	4
3.3	Calculated Values of Electric Fields.....	5
3.4	Environmental Electric Fields.....	6
<b>4.0</b>	<b>Magnetic Field</b> .....	<b>7</b>
4.1	Basic Concepts.....	7
4.2	Transmission-line Magnetic Fields.....	8
4.3	Calculated Values for Magnetic Fields.....	9
4.4	Environmental Magnetic Fields.....	9
<b>5.0</b>	<b>Electric and Magnetic Field (EMF) Effects</b> .....	<b>12</b>
5.1	Electric Fields: Short-term Effects.....	12
5.2	Magnetic Field: Short-term Effects.....	15
<b>6.0</b>	<b>Regulations</b> .....	<b>16</b>
<b>7.0</b>	<b>Audible Noise</b> .....	<b>17</b>
7.1	Basic Concepts.....	17
7.2	Transmission-line Audible Noise.....	19
7.3	Predicted Audible Noise Levels.....	19
7.4	Discussion.....	20
7.5	Conclusion.....	20
<b>8.0</b>	<b>Electromagnetic Interference</b> .....	<b>20</b>
8.1	Basic Concepts.....	20
8.2	Radio Interference (RI).....	21
8.3	Predicted RI Levels.....	21
8.4	Television Interference (TVI).....	22
8.5	Predicted TVI Levels.....	22
8.6	Interference with Other Devices.....	22
8.7	Conclusion.....	22
<b>9.0</b>	<b>Other Corona Effects</b> .....	<b>23</b>
<b>10.0</b>	<b>Summary</b> .....	<b>23</b>
	<b>List of References Cited</b> .....	<b>25</b>
	<b>List of Preparers</b> .....	<b>29</b>

## List of Tables

Table 1:	Physical and electrical characteristics of Santiam - Bethel Project corridors.....	31
Table 2:	Possible corridors for Santiam - Bethel Project .....	31
Table 3:	Calculated electric fields for configurations of the proposed Santiam - Bethel/ Santiam-Chemawa 230-kV line operated at maximum voltage .....	32
Table 4	Calculated magnetic fields for configurations of the proposed Santiam – Bethel/ Santiam - Chemawa 230-kV line operated at maximum current .....	33
Table 5	States with transmission-line field limits .....	34
Table 6	Common noise levels .....	35
Table 7	Typical sound attenuation (in decibels) provided by buildings .....	35
Table 8	Predicted foul-weather audible noise (AN) levels at edge of right-of-way (ROW) for proposed Santiam – Bethel/Santiam - Chemawa 230-kV line .....	36
Table 9	Predicted fair-weather radio interference (RI) levels at 100 feet (30.5 m) from the outside conductor of the proposed Santiam – Bethel/Santiam - Chemawa 230-kV line.....	36
Table 10	Predicted maximum foul-weather television interference (TVI) levels predicted at 100 feet (30.5 m) from the outside conductor of the proposed Santiam – Bethel/Santiam - Chemawa 230-kV line.....	37

## List of Figures

Figure 1	Configurations for proposed Santiam – Bethel/ Santiam- Chemawa 230-kV line: a) proposed line with no parallel lines (Configuration I); and b) proposed line with parallel 500-kV line (Configuration II).....	38
Figure 2	Electric-field profiles for configurations of proposed Santiam – Bethel/Santiam - Chemawa 230-kV line: a) proposed line with no parallel line (Configuration I); and b) proposed line with parallel 500-kV line (Configuration II) .....	39
Figure 3	Magnetic-field profiles for selected configurations of the proposed Santiam - Bethel/ Santiam – Chemawa 230-kV line for maximum current conditions: a) proposed line with no parallel line (Configuration I); and b) proposed line with parallel 500-kV line (Configuration II).....	40

# ELECTRICAL EFFECTS FROM THE PROPOSED SANTIAM - BETHEL TRANSMISSION PROJECT

## 1.0 Introduction

The Bonneville Power Administration (BPA) is proposing to build a 16.7-mile (mi.) (26.9-kilometer [km]) 230-kilovolt (kV) transmission line from the Santiam Substation near Stayton, Oregon, to a tap point on the existing PGE 230-kV Bethel line near Salem, Oregon. The proposed Santiam - Bethel Transmission Project would replace 16.7 mi. (26.9 km) of the single-circuit Santiam - Chemawa 230-kV line with a double-circuit 230-kV line. The proposed double-circuit line would consist of the new Santiam - Bethel 230-kV line and the rebuilt Santiam - Chemawa 230-kV line. Configurations along the existing line route include the right-of-way with no parallel lines (15.2 mi. or 24.5 km) and the right-of-way parallel to an existing 500-kV line (1.5 mi. or 2.4 km). The purpose of this report is to describe and quantify the electrical effects of the proposed Santiam - Bethel Transmission Project. These include the following:

- the levels of 60-hertz (Hz; cycles per second) electric and magnetic fields (EMF) at 3.28 feet (ft.) or 1 meter (m) above the ground,
- the effects associated with those fields,
- the levels of audible noise produced by the line, and
- electromagnetic interference associated with the line.

Electrical effects occur near all transmission lines, including those already present along the proposed route for the Santiam - Bethel line. Therefore, the levels of these quantities for the proposed line are computed and compared with those from the existing lines along the route.

The voltage on the conductors of transmission lines generates an electric field in the space between the conductors and the ground. The electric field is calculated or measured in units of volts-per-meter (V/m) or kilovolts-per-meter (kV/m) at a height of 3.28 ft. (1 m) above the ground. The current flowing in the conductors of the transmission line generates a magnetic field in the air and earth near the transmission line; current is expressed in units of amperes (A). The magnetic field is expressed in milligauss (mG), and is usually measured or calculated at a height of 3.28 ft. (1 m) above the ground. The electric field at the surface of the conductors causes the phenomenon of corona. Corona is the electrical breakdown or ionization of air in very strong electric fields, and is the source of audible noise, electromagnetic radiation, and visible light.

To quantify EMF levels along the route, the electric and magnetic fields from the proposed and existing lines were calculated using the BPA Corona and Field Effects Program (USDOE, undated). In this program, the calculation of 60-Hz fields uses standard superposition techniques for vector fields from several line sources: in this case, the line sources are transmission-line conductors. (Vector fields have both magnitude and direction: these must be taken into account when combining fields from different sources.) Important input parameters to the computer program are voltage, current, and geometric configuration of the line. The transmission-line conductors are assumed to be straight, parallel to each other, and located above and parallel to an infinite flat ground plane. Although such conditions do not

occur under real lines because of conductor sag and variable terrain, the validity and limitations of calculations using these assumptions have been well verified by comparisons with measurements. This approach was used to estimate fields for the proposed Santiam - Bethel line, where minimum clearances were assumed to provide worst-case (highest) estimates for the fields.

Electric fields are calculated using an imaging method. Fields from the conductors and their images in the ground plane are superimposed with the proper magnitude and phase to produce the total field at a selected location.

The total magnetic field is calculated from the vector summation of the fields from currents in all the transmission-line conductors. Balanced currents are assumed for each three-phase circuit; the contribution of induced image currents in the conductive earth is not included. Peak currents and power flow direction for the proposed and existing lines were provided by BPA and are based on the projected winter peak power loads in 2006. In the case of corridors with more than one line, calculations were performed for similar (maximum) current conditions on both lines.

Electric and magnetic fields for the proposed line were calculated at the standard height (3.28 ft. or 1 m) above the ground (IEEE, 1987). Calculations were performed out to 300 ft. (91 m) from the centerline of the existing corridor. The validity and limitations of such calculations have been well verified by measurements. Because maximum voltage, maximum current, and minimum conductor height above-ground are used, ***the calculated values given here represent worst-case conditions:*** i.e., the calculated fields are higher than they would be in practice. Such worst-case conditions would seldom occur.

The corona performance of the proposed line was also predicted using the BPA Corona and Field Effects Program (USDOE, undated). Corona performance is calculated using empirical equations that have been developed over several years from the results of measurements on numerous high-voltage lines (Chartier and Stearns, 1981; Chartier, 1983). The validity of this approach for corona-generated audible noise has been demonstrated through comparisons with measurements on other lines all over the United States (IEEE Committee Report, 1982). The accuracy of this method for predicting corona-generated radio and television interference from transmission lines has also been established (Olsen et al., 1992). Important input parameters to the computer program are voltage, current, conductor size, and geometric configuration of the line.

Corona is a highly variable phenomenon that depends on conditions along a length of line. Predictions of the levels of corona effects are reported in statistical terms to account for this variability. Calculations of audible noise and electromagnetic interference levels were made under conditions of an estimated average operating voltage (235 kV for the proposed line) and with the average line height (43 ft. or 13.1 m). Levels of audible noise, radio interference, and television interference are predicted for both fair and foul weather; however, corona is basically a foul-weather phenomenon. Wet conductors can occur during periods of rain, fog, snow, or icing. Along the route of the proposed Santiam - Bethel transmission line, such conditions are expected to occur about 22% of the time during a year, based on hourly records for the Salem airport from 1996 to 1999. Corona activity also increases with altitude. For purposes of evaluating corona effects from the proposed line, an altitude of 500 ft. (152 m) was assumed.



## 2.0 Physical Description

### 2.1 Proposed Line

The proposed double-circuit line would consist of two three-phase circuits, the new Santiam - Bethel 230-kV line and the rebuilt Santiam - Chemawa 230-kV line. Both circuits would have maximum phase-to-phase voltages of 242 kV. The average voltage of the lines would be 235 kV. The maximum electrical current on the lines would be 755 and 644 amperes per phase for the Santiam - Bethel and Santiam - Chemawa lines, respectively. The estimated currents are based on the BPA projected normal winter peak load in 2006. The load factor for these loads is 0.60 (average load = peak load x load factor). BPA provided the physical and operating characteristics of the proposed and existing lines.

The physical dimensions and electrical characteristics for the configuration of the proposed line are shown in Figure 1, and summarized in Table 1. Each phase of the proposed and rebuilt 230-kV lines will have a single 1.600-inch (in.) (4.1 centimeter [cm]) diameter steel-reinforced aluminum conductor (ACSR). Voltage and current waves are displaced by 120° in time (one-third of a cycle) on each electrical phase. The horizontal phase spacing between the upper and lower conductor positions of the two circuits would be 24.5 ft. (7.5 m); the horizontal spacing between the middle conductor positions would be 40.5 ft. (12.3 m). The vertical spacing between the conductor positions would be 18 ft. (5.5 m). Minimum conductor-to-ground clearance would be 31 ft. (9.5 m) at a conductor temperature of 122°F (50°C), which represents maximum operating conditions and high ambient air temperatures; clearances above ground would be greater under normal operating temperatures. The average clearance above ground along a span will be approximately 43 ft. (13.1 m); this value was used for corona calculations. At road crossings, the ground clearance would be at least 39 ft. (11.9 m). The 31-ft. (9.5-m) minimum clearance provided by BPA is greater than the minimum distance of the conductors above ground required to meet the National Electric Safety Code (NESC) (IEEE, 1990). The final design of the proposed line could entail larger clearances. The right-of-way width for the proposed line is 125 ft. (38 m).

### 2.2 Existing Lines

The proposed double-circuit 230-kV line would replace a section of the existing Santiam - Chemawa 230-kV line along the entire route. There are two possible configurations along the existing Santiam - Chemawa line route: either no parallel line or parallel to the existing BPA Marion - Santiam No. 1 and No. 2 double-circuit 500-kV line (Table 2).

BPA provided information on currents for the existing Santiam - Chemawa line and for the Marion - Santiam No.1 500-kV line. The Marion - Santiam No. 2 line is not energized. The physical and electrical characteristics of the corridor configurations that were analyzed are given in Table 1; cross-sections of the corridors are shown in Figure 1.

## 3.0 Electric Field

### 3.1 Basic Concepts

An electric field is said to exist in a region of space if an electrical charge, at rest in that space, experiences a force of electrical origin (i.e., electric fields cause free charges to move). Electric field is a vector quantity: that is, it has both magnitude and direction. The direction corresponds to the direction

that a positive charge would move in the field. Sources of electric fields are unbalanced electrical charges (positive or negative) and time-varying magnetic fields. Transmission lines, distribution lines, house wiring, and appliances generate electric fields in their vicinity because of unbalanced electrical charge on energized conductors. The unbalanced charge is associated with the voltage on the energized system. On the power system in North America, the voltage and charge on the energized conductors are cyclic (plus to minus to plus) at a rate of 60 times per second. This changing voltage results in electric fields near sources that are also time-varying at a frequency of 60 hertz (Hz; a frequency unit equivalent to cycles per second).

As noted earlier, electric fields are expressed in units of volts per meter (V/m) or kilovolts (thousands of volts) per meter (kV/m). Electric- and magnetic-field magnitudes in this report are expressed in root-mean-square (rms) units. For sinusoidal waves, the rms amplitude is given as the peak amplitude divided by the square root of two.

The spatial uniformity of an electric field depends on the source of the field and the distance from that source. On the ground, under a transmission line, the electric field is nearly constant in magnitude and direction over distances of several feet (1 meter). However, close to transmission- or distribution-line conductors, the field decreases rapidly with distance from the conductors. Similarly, near small sources such as appliances, the field is not uniform and falls off even more rapidly with distance from the device. If an energized conductor (source) is inside a grounded conducting enclosure, then the electric field outside the enclosure is zero, and the source is said to be shielded.

Electric fields interact with the charges in all matter, including living systems. When a conducting object, such as a vehicle or person, is located in a time-varying electric field near a transmission line, the external electric field exerts forces on the charges in the object, and electric fields and currents are induced in the object. If the object is grounded, then the total current induced in the body (the "short-circuit current") flows to earth. The distribution of the currents within, say, the human body, depends on the electrical conductivities of various parts of the body: for example, muscle and blood have higher conductivity than bone and would therefore experience higher currents.

At the boundary surface between air and the conducting object, the field in the air and perpendicular to the conductor surface is much, much larger than the field in the conductor itself. For example, the average surface field on a human standing in a 10 kV/m field is 27 kV/m; the internal fields in the body are much smaller: approximately 0.008 V/m in the torso and 0.45 V/m in the ankles.

### **3.2 Transmission-line Electric Fields**

The electric field created by a high-voltage transmission line extends from the energized conductors to other conducting objects such as the ground, towers, vegetation, buildings, vehicles, and people. The calculated strength of the electric field at a height of 3.28 ft. (1 m) above an unvegetated, flat earth is frequently used to describe the electric field under straight parallel transmission lines. The most important transmission-line parameters that determine the electric field at a 1-m height are conductor height above ground and line voltage.

Calculations of electric fields from transmission lines are performed with computer programs based on well-known physical principles (cf., Deno and Zaffanella, 1982). The calculated values under these conditions represent an ideal situation. When practical conditions approach this ideal model, measurements and calculations agree. Often, however, conditions are far from ideal because of variable terrain and vegetation. In these cases, fields are calculated for ideal conditions, with the lowest conductor clearances to provide upper bounds on the electric field under the transmission lines. With the

use of more complex models or empirical results, it is also possible to account accurately for variations in conductor height, topography, and changes in line direction. Because the fields from different sources add vectorially, it is possible to compute the fields from several different lines if the electrical and geometrical properties of the lines are known. However, in general, electric fields near transmission lines with vegetation below are highly complex and cannot be calculated. Measured fields in such situations are highly variable.

For evaluation of EMF from transmission lines, the fields must be calculated for a specific line condition. The NESC states the condition for evaluating electric-field-induced short-circuit current for lines with voltage above 98 kV, line-to-ground, as follows: conductors are at a minimum clearance from ground corresponding to a conductor temperature of 120°F (49°C), and at a maximum voltage (IEEE, 1990). BPA has supplied the needed information for calculating electric and magnetic fields from the proposed transmission lines: the maximum operating voltage, the estimated peak current in 2006, and the minimum conductor clearances.

There are standard techniques for measuring transmission-line electric fields (IEEE, 1987). Provided that the conditions at a measurement site closely approximate those of the ideal situation assumed for calculations, measurements of electric fields agree well with the calculated values. If the ideal conditions are not approximated, the measured field can differ substantially from calculated values. Usually the actual electric field at ground level is reduced from the calculated values by various common objects that act as shields.

Maximum or peak field values occur over a small area at midspan, where conductors are closest to the ground. As the location of an electric-field profile approaches a tower, the conductor clearance increases, and the peak field decreases. A grounded tower will reduce the electric field considerably by shielding. For the parallel-line configuration considered here, minimum conductor clearances were assumed to occur along the same lateral profile for both lines. This condition will not necessarily occur in practice, because the towers for the parallel lines may be offset or located at different elevations. The assumption of simultaneous minimum clearance results in peak fields that may be larger than what occurs in practice.

For traditional transmission lines, such as the proposed line, where the right-of-way extends laterally well beyond the conductors, electric fields at the edge of the right-of-way are not as sensitive as the peak field to conductor height. Computed values at the edge of the right-of-way for any line height are fairly representative of what can be expected all along the transmission-line corridor. However, the presence of vegetation on and at the edge of the right-of-way will reduce actual electric-field levels below calculated values.

### **3.3 Calculated Values of Electric Fields**

Table 3 shows the calculated values of electric field at 3.28 ft. (1 m) above ground for the proposed Santiam - Bethel 230-kV transmission-line configurations. The peak value on the right-of-way and the value at the edge of the right-of-way are given for the two proposed corridor configurations and for minimum and average conductor clearances. Figure 2a shows lateral profiles for the electric field from the proposed and existing lines for the minimum conductor heights. Figure 2b shows calculated fields for the proposed and existing lines in the configuration with a parallel 500-kV line.

The calculated peak electric field expected on the right-of-way of the proposed line is 2.5 kV/m when there are no parallel lines. As shown in Figure 2a, the peak values would be present only at locations directly under the line, near mid-span, where the conductors are at the minimum clearance. The

conditions of minimum conductor clearance at maximum current and maximum voltage occur very infrequently. The calculated peak levels are rarely reached under real-life conditions, because the actual line height is generally above the minimum value used in the computer model, because the actual voltage is below the maximum value used in the model, and because vegetation within and near the edge of the right-of-way tends to shield the field at ground level. Maximum electric field under the existing parallel 500-kV is 8.1 kV/m.

The largest values expected at the edge of the right-of-way nearest the proposed line would be 0.4 kV/m. For the parallel configuration, the field at the edge of the right-of-way nearest the 500-kV line would be 0.3 kV/m. The largest electric fields at the edges of the existing rights-of-way are 1.3 and 2.6 kV/m for the 230- and 500-kV lines, respectively.

### **3.4 Environmental Electric Fields**

The electric fields associated with the Santiam - Bethel line can be compared with those found in other environments. Sources of 60-Hz electric (and magnetic) fields exist everywhere electricity is used; levels of these fields in the modern environment vary over a wide range. Electric-field levels associated with the use of electrical energy are orders of magnitude greater than the naturally occurring 60-Hz fields of about 0.0001 V/m, which stem from atmospheric and extraterrestrial sources.

Electric fields in outdoor, publicly accessible places range from less than 1 V/m to 12 kV/m; the large fields exist close to high-voltage transmission lines of 500 kV or higher. In remote areas without electrical service, 60-Hz field levels can be much lower than 1 V/m. Electric fields in home and work environments generally are not spatially uniform like those of transmission lines; therefore, care must be taken when making comparisons between fields from different sources such as appliances and electric lines. In addition, fields from all sources can be strongly modified by the presence of conducting objects. However, it is helpful to know the levels of electric fields generated in domestic and office environments in order to compare commonly experienced field levels with those near transmission lines.

Numerous measurements of residential electric fields have been reported for various parts of the United States, Canada, and Europe. Although there have been no large studies of residential electric fields, sufficient data are available to indicate field levels and characteristics. Measurements of domestic 60-Hz electric fields indicate that levels are highly variable and source-dependent. Electric-field levels are not easily predicted because walls and other objects act as shields, because conducting objects perturb the field, and because homes contain numerous localized sources. Internal sources (wiring, fixtures, and appliances) seem to predominate in producing electric fields inside houses. Average measured electric fields in residences are generally in the range of 5 to 20 V/m. In a large occupational exposure monitoring project that included electric-field measurements at homes, average exposures for all groups away from work were generally less than 10 V/m (Bracken, 1990).

Electric fields from household appliances are localized and decrease rapidly with distance from the source. Local electric fields measured at 1 ft. (0.3 m) from small household appliances are typically in the range of 30 to 60 V/m. Stopps and Janischewskyj (1979) reported electric-field measurements near 20 different appliances; at a 1-ft. (0.3-m) distance, fields ranged from 1 to 150 V/m, with a mean of 33 V/m. In another survey, reported by Deno and Zaffanella (1982), field measurements at a 1-ft. (0.3-m) distance from common domestic and workshop sources were found to range from 3 to 70 V/m. The localized fields from appliances are not uniform, and care should be taken in comparing them with transmission-line fields.

Electric blankets can generate higher localized electric fields. Sheppard and Eisenbud (1977) reported fields of 250 V/m at a distance of approximately 1 ft. (0.3 m). Florig et al. (1987) carried out extensive empirical and theoretical analysis of electric-field exposure from electric blankets and presented results in terms of uniform equivalent fields such as those near transmission lines. Depending on what parameter was chosen to represent intensity of exposure and the grounding status of the subject, the equivalent vertical 60-Hz electric-field exposure ranged from 20 to over 3500 V/m. The largest equivalent field corresponds to the measured field on the chest with the blanket-user grounded. The average field on the chest of an ungrounded blanket-user yields an equivalent vertical field of 960 V/m. As manufacturers have become aware of the controversy surrounding EMF exposures, electric blankets have been redesigned to reduce magnetic fields. However, electric fields from these “low field” blankets are still comparable with those from older designs (Bassen et al., 1991).

Generally, people in occupations not directly related to high-voltage equipment are exposed to electric fields comparable with those of residential exposures. For example, the average electric field measured in 14 commercial and retail locations in rural Wisconsin and Michigan was 4.8 V/m (ITT Research Institute, 1984). Median electric field was about 3.4 V/m. These values are about one-third the values in residences reported in the same study. Power-frequency electric fields near video display terminals (VTDs) are about 10 V/m, similar to those of other appliances (Harvey, 1983). Electric-field levels in public buildings such as shops, offices, and malls appear to be comparable with levels in residences.

In a survey of 1,882 volunteers from utilities, electric-field exposures were measured for 2,082 work days and 657 non-work days (Bracken, 1990). Electric-field exposures for occupations other than those directly related to high-voltage equipment were equivalent to those for non-work exposure.

Thus, except for the relatively few occupations where high-voltage sources are prevalent, electric fields encountered in the workplace are probably similar to those of residential exposures. Even in electric-utility occupations where high field sources are present, exposures to high fields are limited on average to minutes per day.

Electric fields found in publicly accessible areas near high-voltage transmission lines can typically range up to 3 kV/m for 230-kV lines, to 10 kV/m for 500-kV lines, and to 12 kV/m for 765-kV lines. Although these peak levels are considerably higher than the levels found in other public areas, they are present only in limited areas on rights-of-way.

The calculated electric fields for the proposed Santiam - Bethel 230-kV transmission line are consistent with the levels reported for other 230-kV transmission lines in Oregon and elsewhere. The electric fields on and at the edge of the right-of-way from the proposed line will be less than those from the Santiam - Chemawa 230-kV line that would be replaced. Electric fields from the existing 500-kV line will remain the same and be larger than those from the proposed or existing 230-kV lines. The calculated electric fields on the right-of-way of the proposed transmission line would be much higher than levels normally encountered in residences and offices.

## **4.0 Magnetic Field**

### **4.1 Basic Concepts**

Magnetic fields can be characterized by the force they exert on a moving charge or on an electrical current. As with the electric field, the magnetic field is a vector quantity characterized by both magnitude and direction. Electrical currents generate magnetic fields. In the case of transmission lines,

distribution lines, house wiring, and appliances, the 60-Hz electric current flowing in the conductors generates a time-varying, 60-Hz magnetic field in the vicinity of these sources. The strength of a magnetic field is measured in terms of magnetic lines of force per unit area, or magnetic flux density. The term “magnetic field,” as used here, is synonymous with magnetic flux density and is expressed in units of Gauss (G) or milligauss (mG).

The uniformity of a magnetic field depends on the nature and proximity of the source, just as the uniformity of an electric field does. Transmission-line-generated magnetic fields are quite uniform over horizontal and vertical distances of several feet near the ground. However, for small sources such as appliances, the magnetic field decreases rapidly over distances comparable with the size of the device.

The interaction of a time-varying magnetic field with conducting objects results in induced electric field and currents in the object. A changing magnetic field through an area generates a voltage around any conducting loop enclosing the area (Faraday's law). This is the physical basis for the operation of an electrical transformer. For a time-varying sinusoidal magnetic field, the magnitude of the induced voltage around the loop is proportional to the area of the loop, the frequency of the field, and the magnitude of the field. The induced voltage around the loop results in an induced electric field and current flow in the loop material. The induced current that flows in the loop depends on the conductivity of the loop.

## **4.2 Transmission-line Magnetic Fields**

The magnetic field generated by currents on transmission-line conductors extends from the conductors through the air and into the ground. The magnitude of the field at a height of 3.28 ft. (1 m) is frequently used to describe the magnetic field under transmission lines. Because the magnetic field is not affected by non-ferrous materials, the field is not influenced by normal objects on the ground under the line. The direction of the maximum field varies with location. (The electric field, by contrast, is essentially vertical near the ground.) The most important transmission-line parameters that determine the magnetic field at 3.28 ft. (1 m) height are conductor height above ground and magnitude of the currents flowing in the conductors. As distance from the transmission-line conductors increases, the magnetic field decreases.

Calculations of magnetic fields from transmission lines are performed using well-known physical principles (cf., Deno and Zaffanella, 1982). The calculated values usually represent the ideal straight parallel-conductor configuration. For simplicity, a flat earth is usually assumed. Balanced currents (currents of the same magnitude for each phase) are also assumed. This is usually valid for transmission lines, where loads on all three phases are maintained in balance during operation. Induced image currents in the earth are usually ignored for calculations of magnetic field under or near the right-of-way. The resulting error is negligible. Only at distances greater than 300 ft. (91 m) from a line do such contributions become significant (Deno and Zaffanella, 1982). The clearance for magnetic-field calculations for the proposed line was the same as that used for electric-field evaluations.

Standard techniques for measuring magnetic fields near transmission lines are described in ANSI IEEE Standard No. 644-1987 (1987). Measured magnetic fields agree well with calculated values, provided the currents and line heights that go into the calculation correspond to the actual values for the line. To realize such agreement, it is necessary to get accurate current readings during field measurements (because currents on transmission lines can vary considerably over short periods of time) and also to account for all field sources in the vicinity of the measurements.

As with electric fields, the maximum or peak magnetic fields occur in areas near the centerline and at midspan where the conductors are the lowest. The magnetic field at the edge of the right-of-way is not very dependent on line height. If more than one line is present, the peak field will depend on the relative electrical phasing of the conductors and the direction of power flow. Phasing information was available for the parallel 500-kV line. Phasing of the proposed line was selected to minimize magnetic field at the edge of the right-of-way.

### 4.3 Calculated Values for Magnetic Fields

Table 4 gives the calculated values of the magnetic field at 3.28 ft. (1 m) height for the proposed 230-kV transmission-line corridor. Field values on the right-of-way and at the edge of the right-of-way are given for projected maximum currents during winter peak load in 2006, for minimum and average conductor clearances. The maximum currents are 755 A on each of the three phases of the proposed Santiam - Bethel 230-kV line and 644 A on the rebuilt Santiam - Chemawa 230-kV line. Figure 3 shows lateral profiles of maximum magnetic field under this current condition for the two possible corridors of the proposed 230-kV transmission line. The actual magnetic-field levels would vary, as currents on the lines change daily and seasonally and as ambient temperature changes. Average currents over the year would be about 60% of the maximum values. The levels shown in the figures represent the highest magnetic fields expected for the proposed Santiam - Bethel/Santiam - Chemawa 230-kV line. Average fields over a year would be considerably reduced from the peak values, as a result of increased clearances above the minimum value and reduced currents from the maximum value.

The maximum calculated 60-Hz magnetic field expected at 3.28 ft. (1 m) above ground for the proposed line is 87 mG for the proposed line alone and 94 mG when the line parallels the 500-kV line. This field is calculated for the maximum current of 755 A, with the conductors at a height of 31 ft. (9.5 m). The maximum field would decrease for increased conductor clearance. For an average conductor height over a span of 43 ft. (13.1 m), the maximum field would be 50 mG and 58 mG for the proposed line alone and parallel to the 500-kV line, respectively.

At the edge of the right-of-way of the proposed line, the calculated magnetic field for maximum current load conditions is 26 mG. When the line is located parallel to the existing 500-kV line, the field at the edge of the right-of-way adjacent to the proposed line would be 29 mG.

The magnetic field falls off rapidly as distance from the line increases. At a distance of 200 ft. (61 m) from the centerline of the proposed line, the field would be 4 mG for maximum current conditions. The calculated magnetic field for maximum current would be less than 10 mG at about 120 ft. (37 m) from the centerline.

The calculated fields for the two corridors with existing transmission lines are given in Table 4. For the existing lines, the peak magnetic fields on the rights-of-way are 218 mG and 108 mG, for the 230- and 500-kV lines, respectively. Fields at the edges of the existing rights-of-way are 78 mG and 50 mG for the 230- and 500-kV lines, respectively. Addition of the proposed line will not significantly change the magnetic fields under, or at the edge of, the right-of-way of the existing 500-kV line.

### 4.4 Environmental Magnetic Fields

Transmission lines are not the only source of magnetic fields; as with 60-Hz electric fields, 60-Hz magnetic fields are present throughout the environment of a society that relies on electricity as a principal energy source. The magnetic fields associated with the proposed Santiam - Bethel 230-kV line can be compared with fields from other sources. The range of 60-Hz magnetic-field exposures in publicly

accessible locations such as open spaces, transmission-line rights-of-way, streets, pedestrian walkways, parks, shopping malls, parking lots, shops, hotels, public transportation, and so on range from less than 0.1 mG to about 1 G, with the highest values occurring near small appliances with electric motors. In occupational settings in electric utilities, where high currents are present, magnetic-field exposures for workers can be above 1 G. At 60 Hz, the magnitude of the natural magnetic field is approximately 0.0005 mG.

Several investigations of residential fields have been conducted. In a large study to identify and quantify significant sources of 60-Hz magnetic fields in residences, measurements were made in 996 houses, randomly selected throughout the country (Zaffanella, 1993). The most common sources of residential fields were power lines, the grounding system of residences, and appliances. Field levels were characterized by both point-in-time (spot) measurements and 24-hour measurements. Spot measurements averaged over all rooms in a house exceeded 0.6 mG in 50% of the houses and 2.9 mG in 5% of houses. Power lines generally produced the largest average fields in a house over a 24-hour period. On the other hand, grounding system currents proved to be a more significant source of the highest fields in a house. Appliances were found to produce the highest local fields; however, fields fell off rapidly with increased distance. For example, the median field near microwave ovens was 36.9 mG at a distance of 10.5 in. (0.27 m) and 2.1 mG at 46 in. (1.17 m). Across the entire sample of 996 houses, higher magnetic fields were found in, among others, urban areas (vs. rural); multi-unit dwellings (vs. single-family); old houses (vs. new); and houses with grounding to a municipal water system.

In an extensive measurement project to characterize the magnetic-field exposure of the general population, over 1000 randomly selected persons in the United States wore a personal exposure meter for 24 hours and recorded their location in a simple diary (Zaffanella and Kalton, 1998). Based on the measurements of 853 persons, the estimated 24-hour average exposure for the general population is 1.24 mG and the estimated median exposure is 0.88 mG. The average field "at home, not in bed" is 1.27 mG and "at home, in bed" is 1.11 mG. Average personal exposures were found to be largest "at work" (mean of 1.79 mG and median of 1.01 mG) and lowest "at home, in bed" (mean of 1.11 mG and median of 0.49 mG). Average fields in school were also low (mean of 0.88 mG and median of 0.69 mG). Factors associated with higher exposures at home were smaller residences, duplexes and apartments, metallic rather than plastic water pipes, and nearby overhead distribution lines.

As noted above, magnetic fields from appliances are localized and decrease rapidly with distance from the source. Localized 60-Hz magnetic fields have been measured near about 100 household appliances such as ranges, refrigerators, electric drills, food mixers, and shavers (Gauger, 1985). At a distance of 1 ft. (0.3 m), the maximum magnetic field ranged from 0.3 to 270 mG, with 95% of the measurements below 100 mG. Ninety-five percent of the levels at a distance of 4.9 ft. (1.5 m) were less than 1 mG. Devices that use light-weight, high-torque motors with little magnetic shielding exhibited the largest fields. These included vacuum cleaners and small hand-held appliances and tools. Microwave ovens with large power transformers also exhibited relatively large fields. Electric blankets have been a much-studied source of magnetic-field exposure because of the length of time they are used and because of the close proximity to the body. Florig and Hoburg (1988) estimated that the average magnetic field in a person using an electric blanket was 15 mG, and that the maximum field could be 100 mG. New "low-field" blankets have magnetic fields at least 10 times lower than those from conventional blankets (Bassen et al., 1991).

In a domestic magnetic-field survey, Silva et al. (1989) measured fields near different appliances at locations typifying normal use (e.g., sitting at a typewriter or standing at a stove). Specific appliances with relatively large fields included can openers (n = 9), with typical fields ranging from 30 to 225 mG and a maximum value up to 2.7 G; shavers (n = 4), with typical fields from 50 to 300 mG and maximum



fields up to 6.9 G; and electric drills ( $n = 2$ ), with typical fields from 56 to 190 mG and maximum fields up to 1.5 G. The fields from such appliances fall off very rapidly with distance and are only present for short periods. Thus, although instantaneous magnetic-field levels close to small hand-held appliances can be quite large, they do not contribute to average area levels in residences.

Although studies of residential magnetic fields have not all considered the same independent parameters, the following consistent characterization of residential magnetic fields emerges from the data:

- (1) External sources play a large role in determining residential magnetic-field levels. Transmission lines, when nearby, are an important external source. Unbalanced ground currents on neutral conductors and other conductors, such as water pipes in and near a house, can represent a significant source of magnetic field. Distribution lines per se, unless they are quite close to a residence, do not appear to be a traditional distance-dependent source.
- (2) Homes with overhead electrical service appear to have higher average fields than those with underground service.
- (3) Appliances represent a localized source of magnetic fields that can be much higher than average or area fields. However, fields from appliances approach area levels at distances greater than 3 ft. (1 m) from the device.

Although important variables in determining residential magnetic fields have been identified, quantification and modeling of their influence on fields at specific locations is not yet possible. However, a general characterization of residential magnetic-field level is possible: average levels in the United States are in the range of 0.5 to 1.0 mG, with the average field in a small number of homes exceeding this range by as much as a factor of 10 or more. Average personal exposure levels are slightly higher, possibly due to use of appliances and varying distances to other sources. Maximum fields can be much higher.

Magnetic fields in commercial and retail locations are comparable with those in residences. As with appliances, certain equipment or machines can be a local source of higher magnetic fields. Utility workers who work close to transformers, generators, cables, transmission lines, and distribution systems clearly experience high-level fields. Other sources of fields in the workplace include motors, welding machines, computers, and video display terminals (VDTs). In publicly accessible indoor areas, such as offices and stores, field levels are generally comparable with residential levels, unless a high-current source is nearby.

Because high-current sources of magnetic field are more prevalent than high-voltage sources, occupational environments with relatively high magnetic fields encompass a more diverse set of occupations than do those with high electric fields. For example, in occupational magnetic-field measurements reported by Bowman et al. (1988), the geometric mean field from 105 measurements of magnetic field in "electrical worker" job locations was 5.0 mG. "Electrical worker" environments showed the following elevated magnetic-field levels (geometric mean greater than 20 mG): industrial power supplies, alternating current (ac) welding machines, and sputtering systems for electronic assembly. For secretaries in the same study, the geometric mean field was 3.1 mG for those using VDTs ( $n = 6$ ) and 1.1 mG for those not using VDTs ( $n = 3$ ).

Measurements of personal exposure to magnetic fields were made for 1,882 volunteer utility workers for a total of 4,411 workdays (Bracken, 1990). Median workday mean exposures ranged from 0.5 mG for clerical workers without computers to 7.2 mG for substation operators. Occupations not specifically associated with transmission and distribution facilities had median workday exposures less than 1.5 mG,

while those associated with such facilities had median exposures above 2.3 mG. Magnetic-field exposures measured in homes during this study were comparable with those recorded in offices.

Magnetic fields in publicly accessible outdoor areas seem to be, as expected, directly related to proximity to electric-power transmission and distribution facilities. Near such facilities, magnetic fields are generally higher than indoors (residential). Higher-voltage facilities tend to have higher fields. Typical maximum magnetic fields in publicly accessible areas near transmission facilities can range from less than a few milligauss up to 300 mG or more, near heavily loaded lines operated at 230 to 765 kV. The levels depend on the line load, conductor height, and location on the right-of-way. Because magnetic fields near high-voltage transmission lines depend on the current in the line, they can vary daily and seasonally. To characterize fields from the distribution system, Heroux (1987) measured 60-Hz magnetic fields with a mobile platform along 140 mi. (223 km) of roads in Montreal. The median field level averaged over nine different routes was 1.6 mG, with 90% of the measurements less than about 5.1 mG. Spot measurements indicated that typical fields directly above underground distribution systems were 5 to 19 mG. Beneath overhead distribution lines, typical fields were 1.5 to 5 mG on the primary side of the transformer, and 4 to 10 mG on the secondary side. Near ground-based transformers used in residential areas, fields were 80 to 1000 mG at the surface and 10 to 100 mG at a distance of 1 ft. (0.3 m).

The magnetic fields from the proposed 230-kV transmission line would be less than those from the existing 230-kV line that is being replaced. The fields from the proposed line would be comparable to or less than those from existing 230-kV lines in Oregon and elsewhere. On and near the right-of-way of the proposed line, magnetic fields would be well above average residential levels. However, the fields from the line would decrease rapidly and approach common ambient levels at distances greater than a few hundred feet from the line. Furthermore, the fields at the edge of the right-of-way would not be above those encountered during normal activities near common sources such as hand-held appliances.

## **5.0 Electric and Magnetic Field (EMF) Effects**

Possible effects associated with the interaction of EMF from transmission lines with people on and near a right-of-way fall into two categories: short-term effects that can be perceived and may represent a nuisance, and possible long-term health effects. Only short-term effects are discussed here. The issue of whether there are long-term health effects associated with transmission-line fields is controversial. In recent years, considerable research on possible biological effects of EMF has been conducted. A review of these studies and their implications for health-related effects is provided in a separate technical report for the environmental assessment for the proposed Santiam - Bethel 230-kV transmission line.

### **5.1 Electric Fields: Short-term Effects**

Short-term effects from transmission-line electric fields are associated with perception of induced currents and voltages or perception of the field. Induced current or spark discharge shocks can be experienced under certain conditions when a person contacts objects in an electric field. Such effects occur in the fields associated with transmission lines that have voltages of 230-kV or higher. These effects could occur infrequently under the proposed Santiam - Bethel 230-kV line. The higher electric fields under the existing 500-kV Marion-Santiam line are much more likely to result in such effects.

Steady-state currents are those that flow continuously after a person contacts an object and provides a path to ground for the induced current. The amplitude of the steady-state current depends on the induced current to the object in question and on the grounding path. The magnitude of the induced current to vehicles and objects under the proposed line will depend on the electric-field strength and the size and

shape of the object. When an object is electrically grounded, the voltage on the object is reduced to zero, and it is not a source of current or voltage shocks. If the object is poorly grounded or not grounded at all, then it acquires some voltage relative to earth and is a possible source of current or voltage shocks.

The responses of persons to steady-state current shocks have been extensively studied, and levels of response documented (Keesey and Letcher, 1969; IEEE, 1978). Primary shocks are those that can result in direct physiological harm. Such shocks will not be possible from induced currents under the existing or proposed lines, because clearances above ground required by the NESC preclude such shocks from large vehicles and grounding practices eliminate large stationary objects as sources of such shocks.

Secondary shocks are defined as those that could cause an involuntary and potentially harmful movement, but no direct physiological harm. Secondary shocks could occur under the proposed 230-kV line when making contact with ungrounded conducting objects such as vehicles or equipment. However, such occurrences are anticipated to be very infrequent. Shocks, when they occur under the 230-kV line, are most likely to be below the nuisance level. Induced currents are extremely unlikely to be perceived off the right-of-way of the proposed line.

Induced currents are always present in electric fields under transmission lines and will be present near the proposed line. However, during initial construction, BPA routinely grounds metal objects that are located on or near the right-of-way. The grounding eliminates these objects as sources of induced current and voltage shocks. Multiple grounding points are used to provide redundant paths for induced current flow. After construction, BPA would respond to any complaints and install or repair grounding to mitigate nuisance shocks.

Unlike fences or buildings, mobile objects such as vehicles and farm machinery cannot be grounded permanently. Limiting the possibility of induced currents from such objects to persons is accomplished in several ways. First, required clearances for above-ground conductors tend to limit field strengths to levels that do not represent a hazard or nuisance. The NESC (IEEE, 1990) requires that, for lines with voltage exceeding 98 kV line-to-ground (170 kV line-to-line), sufficient conductor clearance be maintained to limit the induced short-circuit current in the largest anticipated vehicle under the line to 5 milliamperes (mA) or less. This can be accomplished by limiting access or by increasing conductor clearances in areas where large vehicles could be present. BPA and other utilities design and operate lines to be in compliance with the NESC.

For the proposed line, conductor clearances (50°C conductor temperature) would be increased to at least 39 ft. (11.9 m) over road crossings along the route, resulting in a maximum field of 1.7 kV/m or less at the 3.28 ft. (1 m) height. The largest truck allowed on roads in Oregon without a special permit is 14 feet high by 8.5 feet wide by 75 feet long (4.3 x 2.6 x 22.9 m). The induced currents to such a vehicle oriented perpendicular to the line in a maximum field of 1.7 kV/m (at 3.28-foot height) would be less than 1.5 mA (Reilly, 1979). For smaller trucks, the maximum induced currents for perpendicular orientation to the proposed line would be less than this value. (Larger special-permitted trucks, such as triple trailers, can be up to 105 feet in length. However, because they average the field over such a long distance, the maximum induced current to a 105-foot vehicle oriented perpendicular to the 230-kV line at a road crossing would be less than 1.4 mA.) Thus, the NESC 5-mA criterion would be met for perpendicular road crossings of the proposed line. These large vehicles are not anticipated to be off highways or oriented parallel to the proposed line. Even if they were, the NESC 5-mA criterion would be met under the proposed line. As discussed below, these are worst-case estimates of induced currents at road crossings; conditions for their occurrence are rare. The conductor clearance at each road crossing would be checked during the design stage of the line to ensure that the NESC 5-mA criterion is met. Furthermore, it is BPA policy to limit the maximum induced current from vehicles to 2 mA in

commercial parking lots. Line clearances would also be increased in accordance with the NESC, such as over railroads and water areas suitable for sailboating.

Several factors tend to reduce the levels of induced current shocks from vehicles:

- (1) Activities are distributed over the whole right-of-way, and only a small percentage of time is spent in areas where the field is at or close to the maximum value.
- (2) At road crossings, vehicles are aligned perpendicular to the conductors, resulting in a substantial reduction in induced current.
- (3) The conductor clearance at road crossings may not be at minimum values because of lower conductor temperatures and/or location of the road crossing away from midspan.
- (4) The largest vehicles are permitted only on certain highways.
- (5) Off-road vehicles are in contact with soil or vegetation, which reduces shock currents substantially.

Induced voltages occur on objects, such as vehicles, in an electric field where there is an inadequate electrical ground. If the voltage is sufficiently high, then a spark discharge shock can occur as contact is made with the object. Such shocks are similar to "carpet" shocks that occur, for example, when a person touches a doorknob after walking across a carpet on a dry day.

In electric fields higher than will occur under the proposed line, it is theoretically possible for a spark discharge from the induced voltage on a large vehicle to ignite gasoline vapor during refueling. The probability for exactly the right conditions to occur for ignition is extremely remote. The additional clearance of conductors provided at road crossings reduces the electric field in areas where vehicles are prevalent and reduces the chances for such events. Even so, BPA recommends that vehicles should not be refueled under the proposed line unless specific precautions are taken to ground the vehicle and the fueling source (USDOE, 1995).

Under certain conditions, the electric field can be perceived through hair movement on an upraised hand or arm of a person standing on the ground under high-voltage transmission lines. The median field for perception in this manner was 7 kV/m for 136 persons; only about 12% could perceive fields of 2 kV/m or less (Deno and Zaffanella, 1982). Even in areas under the conductors at midspan, the fields at ground level would be below the levels where field perception normally occurs. Therefore, it is unlikely that the field would be perceived anywhere on the right-of-way. Where vegetation provides shielding, the field would not be perceived.

Conductive shielding reduces both the electric field and induced effects such as shocks. Persons inside a vehicle cab or canopy are shielded from the electric field. Similarly, a row of trees or a lower-voltage distribution line reduces the field on the ground in the vicinity. Metal pipes, wiring, and other conductors in a residence or building shield the interior from the transmission-line electric field.

Thus, potential impacts of electric fields can be mitigated through grounding policies, adherence to the NESC, and increased clearances above the minimums specified by the NESC. Worst-case levels are used for safety analyses but, in practice, induced currents and voltages are reduced considerably by unintentional grounding. Shielding by conducting objects, such as vehicles and vegetation, also reduces the potential for electric-field effects.

The electric fields from the proposed 230-kV line will be less than those from the line it is replacing. Therefore the potential for impacts of electric fields will be reduced from that now present on the existing right-of-way. The potential for effects from the parallel 500-kV line will remain the same.

## **5.2 Magnetic Field: Short-term Effects**

Magnetic fields associated with transmission and distribution systems can induce voltage and current in long conducting objects that are parallel to the transmission line. As with electric-field induction, these induced voltages and currents are a potential source of shocks. A fence, irrigation pipe, pipeline, electrical distribution line, or telephone line forms a conducting loop when it is grounded at both ends. The earth forms the other portion of the loop. The magnetic field from a transmission line can induce a current to flow in such a loop if it is oriented parallel to the line. If only one end of the fence is grounded, then an induced voltage appears across the open end of the loop. The possibility for a shock exists if a person closes the loop at the open end by contacting both the ground and the conductor. The magnitude of this potential shock depends on the following factors: the magnitude of the field; the length of the object (the longer the object, the larger the induced voltage); the orientation of the object with respect to the transmission line (parallel as opposed to perpendicular, where no induction would occur); and the amount of electrical resistance in the loop (high resistance limits the current flow).

Magnetically induced currents from power lines have been investigated for many years; calculation methods and mitigating measures are available. A comprehensive study of gas pipelines near transmission lines developed prediction methods and mitigation techniques specifically for induced voltages on pipelines (Dabkowski and Taflove, 1979; Taflove and Dabkowski, 1979). Similar techniques and procedures are available for irrigation pipes and fences. Grounding policies employed by utilities for long fences reduce the potential magnitude of induced voltage.

The magnitude of the coupling with both pipes and fences is very dependent on the electrical unbalance (unequal currents) among the three phases of the line. Thus, a distribution line where a phase outage may go unnoticed for long periods of time can represent a larger source of induced currents than a transmission line where the loads are well-balanced (Jaffa and Stewart, 1981).

Knowledge of the phenomenon, grounding practices, and the availability of mitigation measures mean that magnetic-induction effects from the proposed 230-kV transmission line will be minimal.

Magnetic fields from transmission and distribution facilities can interfere with certain electronic equipment. Magnetic fields can cause distortion of the image on VDTs and computer monitors. The threshold field for interference depends on the type and size of monitor and the frequency of the field. Interference has been observed for certain monitors at fields at or below 10 mG (Baishiki et al., 1990; Banfai et al., 2000). Generally, the problem arises when computer monitors are in use near electrical distribution facilities in large office buildings. Fields from the proposed line would fall below this level at approximately 120 ft. (37 m) from the centerline.

Interference from magnetic fields can be eliminated by shielding the affected monitor or moving it to an area with lower fields. Similar mitigation methods could be applied to other sensitive electronics, if necessary. Interference from 60-Hz fields with computers and control circuits in vehicles and other equipment is not anticipated at the field levels found under and near the proposed 230-kV transmission line.

The magnetic fields from the proposed line will be less than those from the existing line that is being replaced. Therefore the potential for impacts from magnetic fields will be reduced from that on the existing right-of-way. The potential for effects from the parallel 500-kV line will remain the same.

## **6.0 Regulations**

Regulations that apply to transmission-line electric and magnetic fields fall into two categories. Safety standards or codes are intended to limit or eliminate electric shocks that could seriously injure or kill persons. Field limits or guidelines are intended to limit electric- and magnetic-field exposures that can cause nuisance shocks or might cause health effects. In no case has a limit or standard been established because of a known or demonstrated health effect.

The proposed line would be designed to meet the NESC (IEEE, 1990), which specifies how far transmission-line conductors must be from the ground and other objects. The clearances specified in the code provide safe distances that prevent harmful shocks to workers and the public. In addition, people who live and work near transmission lines must be aware of safety precautions to avoid electrical (which is not necessarily physical) contact with the conductors. For example, farmers should not up-end irrigation pipes under a transmission or other electrical line. In addition, as a matter of safety, the NESC specifies that electric-field-induced currents from transmission lines must be below the 5 mA (“let go”) threshold deemed a lower limit for primary shock. BPA publishes and distributes a brochure that describes safe practices to protect against shock hazards around power lines (USDOE, 1995).

Field limits or guidelines have been adopted in several states and countries and by national and international organizations. Electric-field limits have generally been based on minimizing nuisance shocks or field perception. The intent of magnetic-field limits has been to limit exposures to existing levels, given the uncertainty of their potential for health effects.

There are currently no national standards in the United States for 60-Hz electric and magnetic fields. Several states have been active in establishing mandatory or suggested limits on 60-Hz electric and (in two cases) magnetic fields. Six states have specific electric-field limits that apply to transmission lines: Florida, Minnesota, Montana, New Jersey, New York, and Oregon. Florida and New York have established regulations for magnetic fields. These regulations are summarized in Table 5, adapted from TDHS Report (1989).

Electric-field limits for the states have been given in terms of maximum field or edge-of-right-of-way field, or both. The Oregon limit of 9 kV/m for electric fields is applied to areas accessible to the public (Oregon, 1980). The Oregon rule, which is found in transmission-line siting procedures also addresses grounding practices, audible noise, and radio interference.

Government agencies and utilities operating transmission systems have established design criteria that include EMF levels. BPA has maximum allowable electric fields of 9 and 5 kV/m on and at the edge of the right-of-way, respectively (USDOE, 1996). BPA also has maximum-allowable electric field strengths of 5 kV/m, 3.5 kV/m, and 2.5 kV/m for road crossings, shopping center parking lots, and commercial/industrial parking lots, respectively. These levels are based on limiting the maximum short-circuit currents from anticipated vehicles to less than 1 mA in shopping center lots and to less than 2 mA in commercial parking lots.

Electric-field limits for overhead power lines have also been established in other countries (Maddock, 1992). Limits for magnetic fields from overhead power lines have not been explicitly established

anywhere except in Florida and New York. However, general guidelines and limits on EMF have been established for occupational and public exposure in several countries and by national and international organizations.

The American Conference of Governmental Industrial Hygienists (ACGIH) sets guidelines (Threshold Limit Values or TLV) for occupational exposures to environmental agents (ACGIH, 2000). In general, a TLV represents the level below which it is believed that nearly all workers may be exposed repeatedly without adverse health effects. For EMF, the TLVs represent ceiling levels. For 60-Hz electric fields, occupational exposures should not exceed the TLV of 25 kV/m. However, the ACGIH also recognizes the potential for startle reactions from spark discharges and short-circuit currents in fields greater than 5-7 kV/m, and recommends implementing grounding practices. They recommend the use of conductive clothing for work in fields exceeding 15 kV/m. The TLV for occupational exposure to 60-Hz magnetic fields is a ceiling level of 10 G (10,000 mG) (ACGIH, 2000).

Electric and magnetic fields from various sources (including automobile ignitions, appliances, and, possibly, transmission lines) can interfere with implanted cardiac pacemakers. In light of this potential problem, manufacturers design devices to be immune from such interference. However, research has shown that these efforts have not been completely successful and that a few models of pacemakers could be affected by 60-Hz fields from transmission lines. There were also numerous models of pacemakers that were not affected by fields even larger than those found under transmission lines. Because of the known potential for interference with pacemakers by 60-Hz fields, field limits for pacemaker wearers have been established by the ACGIH. They recommend that wearers of pacemakers and similar medical-assist devices limit their exposure to electric fields of 1 kV/m or less and to magnetic fields to 1 G (1,000 mG) or less (ACGIH, 2000).

The International Committee on Non-ionizing Radiation Protection (ICNIRP), working in cooperation with the World Health Organization (WHO) has developed guidelines for occupational and public exposures to EMF (ICNIRP, 1998). For occupational exposures at 60 Hz, the recommended limits to exposure are 8.3 kV/m for electric fields and 4.2 G (4,200 mG) for magnetic fields. The electric-field level can be exceeded, provided precautions are taken to prevent spark discharge and induced current shocks. For the general public, the ICNIRP guidelines recommend exposure limits of 4.2 kV/m for electric fields and 0.83 G (830 mG) for magnetic fields (ICNIRP, 1998).

ICNIRP has also established guidelines for contact currents, which could occur when a grounded person contacts an ungrounded object in an electric field. The guideline levels are 1.0 mA for occupational exposure and 0.5 mA for public exposure.

The estimated peak electric field and magnetic field on, and at the edge of, the right-of-way of the proposed transmission line would meet limits set in all states, including Oregon. The electric fields from the proposed 230-kV line would meet the ACGIH standards, provided wearers of pacemakers and similar medical-assist devices are discouraged from unshielded right-of-way use. (A passenger in an automobile under the line would be shielded from the electric field.) The electric fields from the proposed line would meet the ICNIRP guideline for public exposure. The magnetic fields from the proposed line would be below the ACGIH and IRPA/INIRC limits. The electric fields present on the right-of-way could induce currents in ungrounded vehicles that exceeded the ICNIRP level of 0.5 mA.

## **7.0 Audible Noise**

### **7.1 Basic Concepts**

Audible noise (AN), as defined here, represents an unwanted sound, as from a transmission line, transformer, airport, or vehicle traffic. Sound is a pressure wave caused by a sound source vibrating or displacing air. The ear converts the pressure fluctuations into auditory sensations. AN from a source is superimposed on the background or ambient noise that is present before the source is introduced.

The amplitude of a sound wave is the incremental pressure resulting from sound above atmospheric pressure. The sound-pressure level is the fundamental measure of AN; it is generally measured on a logarithmic scale with respect to a reference pressure. The sound-pressure level (SPL) in decibels (dB) is given by:

$$\text{SPL} = 20 \log (P/P_0)\text{dB}$$

where P is the effective rms (root-mean-square) sound pressure, P<sub>0</sub> is the reference pressure, and the logarithm (log) is to the base 10. The reference pressure for measurements concerned with hearing is usually taken as 20 micropascals (Pa), which is the approximate threshold of hearing for the human ear. A logarithmic scale is used to encompass the wide range of sound levels present in the environment. The range of human hearing is from 0 dB up to about 140 dB, a ratio of 10 million in pressure (EPA, 1978).

Logarithmic scales, such as the decibel scale, are not directly additive: to combine decibel levels, the dB values must be converted back to their respective equivalent pressure values, the total rms pressure level found, and the dB value of the total recalculated. For example, adding two sounds of equal level on the dB scale results in a 3 dB increase in sound level. Such an increase in sound pressure level of 3 dB, which corresponds to a doubling of the energy in the sound wave, is barely discernible by the human ear. It requires an increase of about 10 dB in SPL to produce a subjective doubling of sound level for humans. The upper range of hearing for humans (140 dB) corresponds to a sharply painful response (EPA, 1978).

Humans respond to sounds in the frequency range of 16 to 20,000 Hz. The human response depends on frequency, with the most sensitive range roughly between 2000 and 4000 Hz. The frequency-dependent sensitivity is reflected in various weighting scales for measuring audible noise. The A-weighted scale weights the various frequency components of a noise in approximately the same way that the human ear responds. This scale is generally used to measure and describe levels of environmental sounds such as those from vehicles or occupational sources. The A-weighted scale is also used to characterize transmission-line noise. Sound levels measured on the A-scale are expressed in units of dB(A) or dBA.

AN levels and, in particular, corona-generated audible noise (see below) vary in time. In order to account for fluctuating sound levels, statistical descriptors have been developed for environmental noise. Exceedence levels (L levels) refer to the A-weighted sound level that is exceeded for a specified percentage of the time. Thus, the L<sub>5</sub> level refers to the noise level that is exceeded only 5% of the time. L<sub>50</sub> refers to the sound level exceeded 50% of the time. Sound-level measurements and predictions for transmission lines are often expressed in terms of exceedence levels, with the L<sub>5</sub> level representing the maximum level and the L<sub>50</sub> level representing a median level.

Table 6 shows AN levels from various common sources. Clearly, there is wide variation. Noise exposure depends on how much time an individual spends in different locations. Outdoor noise generally does not contribute to indoor levels (EPA, 1974). Activities in a building or residence generally dominate interior AN levels. The amount of sound attenuation (reduction) provided by buildings is given in Table 7. Assuming that residences along the line route fall in the "warm climate, windows open" category, the typical sound attenuation provided by a house is about 12 dBA.



The BPA design criterion for corona-generated audible noise ( $L_{50}$ , foul weather) is  $50 \pm 2$  dBA at the edge of the ROW. This criterion has been interpreted by the state and BPA to meet Oregon Noise Control Regulations (Perry, 1982). The Environmental Protection Agency (EPA) has established a guideline of 55 dBA for the annual average day-night level ( $L_{dn}$ ) in outdoor areas (EPA, 1978). In computing this value, a 10 dB correction (penalty) is added to night-time noise between the hours of 10 p.m. and 7 a.m.

## 7.2 Transmission-line Audible Noise

Corona is the partial electrical breakdown of the insulating properties of air around the conductors of a transmission line. In a small volume near the surface of the conductors, energy and heat are dissipated. Part of this energy is in the form of small local pressure changes that result in audible noise. Corona-generated audible noise can be characterized as a hissing, crackling sound that, under certain conditions, is accompanied by a 120-Hz hum.

Corona-generated audible noise is of concern primarily for contemporary lines operating at voltages of 345 kV and higher during foul weather. Thus in the area where the proposed 230-kV line parallels a 500-kV line, audible noise from the higher voltage line will predominate. In other areas, the proposed 230-kV line will produce some noise under foul-weather conditions.

The conductors of high-voltage transmission lines are designed to be corona-free under ideal conditions. However, protrusions on the conductor surface—particularly water droplets on or dripping off the conductors—cause electric fields near the conductor surface to exceed corona onset levels, and corona occurs. Therefore, audible noise from transmission lines is generally a foul-weather (wet-conductor) phenomenon. Wet conductors can occur during periods of rain, fog, snow, or icing. Based on meteorologic records near the route of the proposed transmission line, such conditions are expected to occur less than 22% of the time during the year. For a few months after line construction, residual grease or oil on the conductors can cause water to bead up on the surface. This results in more corona sources and slightly higher levels of audible noise and electromagnetic interference if the line is energized. However, the new conductors "age" in a few months, and the level of corona activity decreases to the predicted equilibrium value. During fair weather, insects and dust on the conductor can also serve as sources of corona. The proposed line has been designed with 1.600-in. (4.1-cm) diameter conductors that will yield acceptable corona levels.

## 7.3 Predicted Audible Noise Levels

The predicted levels of corona-generated audible noise for the proposed line operated at a voltage of 235 kV are given in Table 8. For comparison, Table 8 also gives the calculated levels for the existing lines. Audible noise levels are calculated for average voltage and average conductor heights for fair- and foul-weather conditions. The calculated median level ( $L_{50}$ ) during foul weather at the edge of the proposed Santiam - Bethel right-of-way is about 39 dBA, which is less than that from the existing Santiam - Chemawa 230-kV line. Where the proposed Santiam - Bethel line parallels the Marion - Santiam 500-kV line, noise from the higher-voltage line will predominate and there would be no change in noise levels from existing conditions. For this configuration, the noise at the edge of the right-of-way near the proposed line would be 47 dBA.

During fair-weather conditions, which occur about 78% of the time, audible noise levels at the edge of the right-of-way would be about 20 dBA lower (if corona were present). These lower levels could be masked by ambient noise on and off the right-of-way.

## 7.4 Discussion

The calculated foul-weather corona noise levels for the proposed line would be less than those under the existing conditions and comparable to or less than those from existing 230-kV lines in Oregon. During fair weather, noise from the conductors might be perceivable on the right-of-way, but beyond the right-of-way it would likely be masked or so low as to not be perceived even during foul weather when ambient noise is higher.

Off the right-of-way, the levels of audible noise from the proposed line would be well below the 55 dBA level that can produce interference with speech outdoors. Since residential buildings provide significant sound attenuation (-12 dBA with windows open; -24 dBA with windows closed), the noise levels off the right-of-way would be well below the 45 dBA level required for interference with speech indoors and well below the 35 dBA level where sleep interference can occur (EPA, 1973; EPA, 1978). Since corona is a foul-weather phenomenon, people tend to be inside with windows possibly closed, providing additional attenuation when corona noise is present. In addition, ambient noise levels can be high during such periods (due to rain hitting foliage or buildings), and can mask corona noise.

The 39-dBA and 47-dBA levels would meet the BPA design criterion and, hence, the Oregon Noise Control Regulations for transmission lines. The 2 dBA decrease in noise at the edge of the right-of-way associated with the proposed line would probably not be discernible.

The computed annual  $L_{dn}$  level for transmission lines operating in areas with about 22% foul weather is about  $L_{dn} = L_{50} + 1$  dB (Bracken, 1987). Therefore, assuming such conditions in the Santiam - Bethel area, the estimated  $L_{dn}$  at the edge of the right-of-way would be approximately 40 or 48 dBA, which is below the EPA  $L_{dn}$  guideline of 55 dBA.

## 7.5 Conclusion

Along the proposed line route, there would be slight decreases, or no change, in the perceived noise above ambient levels during foul weather at the edges of the right-of-way. Along the existing corridor, the corona-generated noise during foul weather would be masked to some extent by naturally occurring sounds such as wind and rain on foliage. During fair weather, the noise off the right-of-way from the proposed line would probably not be detectable above ambient levels. However, noise from the existing 500-kV line could be perceived as much as under existing conditions. The noise levels from the proposed line would be below levels identified as causing interference with speech or sleep. The audible noise from the transmission line would be below EPA guideline levels and would meet the BPA design criterion that complies with the Oregon State noise regulations.

## 8.0 Electromagnetic Interference

### 8.1 Basic Concepts

Corona on transmission-line conductors can also generate electromagnetic noise in the frequency bands used for radio and television signals. The noise can cause radio and television interference (RI and TVI). In certain circumstances, corona-generated electromagnetic interference (EMI) can also affect communications systems and other sensitive receivers. Interference with electromagnetic signals by corona-generated noise is generally associated with lines operating at voltages of 345 kV or higher. This is especially true of interference with television signals. The 1.600-in. (4.1-cm) diameter conductor used

in the design of the proposed 230-kV line will mitigate corona generation and thus keep radio and television interference levels at acceptable levels.

Spark gaps on distribution lines and on low-voltage wood-pole transmission lines are a more common source of RI/TVI than is corona from high-voltage electrical systems. This gap-type interference is primarily a fair-weather phenomenon caused by loose hardware and wires. The proposed transmission line would be constructed with modern hardware that eliminates such problems and therefore minimizes gap noise. Consequently, this source of EMI is not anticipated for the proposed line.

No state has limits for either RI or TVI. In the United States, electromagnetic interference from power transmission systems is governed by the Federal Communications Commission (FCC) Rules and Regulations presently in existence (FCC, 1988). A power transmission system falls into the FCC category of "incidental radiation device," which is defined as "a device that radiates radio frequency energy during the course of its operation although the device is not intentionally designed to generate radio frequency energy." Such a device "shall be operated so that the radio frequency energy that is emitted does not cause harmful interference. In the event that harmful interference is caused, the operator of the device shall promptly take steps to eliminate the harmful interference." For purposes of these regulations, harmful interference is defined as: "any emission, radiation or induction which endangers the functioning of a radio navigation service or of other safety services or seriously degrades, obstructs or repeatedly interrupts a radio communication service operating in accordance with this chapter" (FCC, 1988: Vol II, part 15. 47CFR, Ch. 1).

Electric power companies have been able to work quite well under the present FCC rule because harmful interference can generally be eliminated. It has been estimated that more than 95% of power-line sources that cause interference are due to gap-type discharges. These can be found and completely eliminated, when required to prevent interference (USDOE, 1980). Complaints related to corona-generated interference occur infrequently. This is especially true with the advent of cable television and satellite television, which are not subject to corona-generated interference. Mitigation of corona-generated interference with conventional radio and television receivers can be accomplished in several ways, such as use of a directional antenna or relocation of an existing antenna (USDOE, 1977; USDOE, 1980; Loftness et al., 1981).

## **8.2 Radio Interference (RI)**

Radio reception in the AM broadcast band (535 to 1605 kilohertz (kHz)) is most often affected by corona-generated EMI. FM radio reception is rarely affected. Generally, only residences very near to transmission lines can be affected by RI. The IEEE Radio Noise Design Guide identifies an acceptable limit of fair-weather RI as expressed in decibels above 1 microvolt per meter (dB $\mu$ V/m) of about 40 dB $\mu$ V/m at 100 ft. (30 m) from the outside conductor (IEEE Committee Report, 1971). As a general rule, average levels during foul weather (when the conductors are wet) are 16 to 22 dB $\mu$ V/m higher than average fair-weather levels.

## **8.3 Predicted RI Levels**

Table 9 gives the predicted fair- and foul-weather RI levels at 100 ft. (30 m) from the outside conductor for the proposed 230-kV line in the two corridor configurations. Median foul-weather levels would be about 17 dB higher than the fair-weather levels. The predicted L<sub>50</sub> fair-weather level at the edge of the right-of-way is 34 dB $\mu$ V/m for 235-kV line operation; at 100 ft. (30 m) from the outside conductor, the level is 26 dB $\mu$ V/m. Predicted fair-weather L<sub>50</sub> levels are lower than that from the existing 230-kV Santiam - Chemawa 230-kV line. Predictions indicate that fair-weather RI will meet the IEEE

40 dB $\mu$ V/m criterion at distances greater than about 10 ft. (3 m) from the outside conductor of the proposed line.

#### **8.4 Television Interference (TVI)**

Corona-caused TVI occurs during foul weather and is generally of concern for transmission lines with voltages of 345 kV or above, and only for conventional receivers within about 600 ft. (183 m) of a line. As is the case for RI, gap sources on distribution and low-voltage transmission lines are the principal observed sources of TVI. The use of modern hardware and construction practices for the proposed line would minimize such sources.

#### **8.5 Predicted TVI Levels**

Table 10 shows TVI levels predicted at 100 ft. (30 m) from the outside conductor of the proposed line operating at 235 kV and from existing lines. At this distance, the foul-weather TVI level predicted for the proposed line is 10 dB $\mu$ V/m. This level is lower than that from the existing Santiam - Chemawa 230-kV line. Replacement of the existing line with the proposed line will reduce TVI levels along the right-of-way.

Other forms of TVI from transmission lines are signal reflection (ghosting) and signal blocking caused by the relative locations of the transmission structure and the receiving antenna with respect to the incoming television signal. The proposed structures are steel and larger than the existing wood structures; they could cause reflection or ghosting and affect reception in rare instances. Television systems that operate at higher frequencies, such as satellite receivers, are not affected by corona-generated TVI. Cable television systems are similarly unaffected.

Interference with television reception can be corrected by any of several approaches: improving the receiving antenna system; installing a remote antenna; installing an antenna for TV stations less vulnerable to interference; connecting to an existing cable system; or installing a translator (cf. USDOE, 1977). BPA has an active program to identify, investigate, and mitigate legitimate RI and TVI complaints. It is anticipated that any instances of TVI caused by the proposed line could be effectively mitigated.

#### **8.6 Interference with Other Devices**

Corona-generated interference can conceivably cause disruption on other communications bands such as the citizen's (CB) and mobile bands. However, mobile-radio communications are not susceptible to transmission-line interference because they are generally frequency modulated (FM). Similarly, cellular telephones operate at a frequency of about 900 MHz, which is above the frequency where corona-generated interference is prevalent. In the unlikely event that interference occurs with these or other communications, mitigation can be achieved with the same techniques used for television and AM radio interference. However, the addition of the proposed line would lower interference levels in the corridor; consequently, no impact is anticipated.

#### **8.7 Conclusion**

Predicted EMI levels for the proposed 230-kV transmission line are lower than those that already exist 230-kV lines; no impacts of corona-generated interference on radio, television, or other reception are anticipated above those already present. Furthermore, if interference should occur, there are various methods for correcting it: BPA has a program to respond to legitimate complaints.

## 9.0 Other Corona Effects

Corona is visible as a bluish glow or as bluish plumes. On the proposed 230-kV line, corona levels would be very low, so that corona on the conductors would be observable only under the darkest conditions and only with the aid of binoculars, if at all. Without a period of adaptation for the eyes and without intentional looking for the corona, it would not be noticeable.

When corona is present, the air surrounding the conductors is ionized and many chemical reactions take place, producing small amounts of ozone and other oxidants. Ozone is approximately 90% of the oxidants, while the remaining 10% is composed principally of nitrogen oxides. The national primary ambient air quality standard for photochemical oxidants, of which ozone is the principal component, is 235 micrograms/cubic meter) or 120 parts per billion. The maximum incremental ozone levels at ground level produced by corona activity on the proposed transmission line during foul weather would be much less than 1 part per billion. This level is insignificant when compared with natural levels and fluctuations in natural levels.

## 10.0 Summary

Electric and magnetic fields from the proposed transmission line have been characterized using well-known techniques accepted within the scientific and engineering community. The expected electric-field levels from the proposed line at minimum design clearance would be less than those from the existing line in the corridor and comparable to, or less than, those from other 230-kV lines in Oregon and elsewhere. The expected magnetic-field levels from the proposed line would be less than those from the existing line that would be replaced and comparable to, or less than, those from other 230-kV lines in Oregon and elsewhere.

The peak electric field expected under the proposed line would be 2.5 kV/m; the maximum value at the edge of the right-of-way would be about 0.4 kV/m. Clearances at road crossings would be increased to reduce the peak electric-field value to 1.7 kV/m.

Under maximum current conditions, the maximum magnetic fields under the proposed line would be 96 mG; at the edge of the right-of-way nearest to the proposed 230-kV line, the magnetic field would be 29 or 26 mG, depending on whether the line parallels an existing 500-kV line or not.

The electric and magnetic fields from the proposed line would meet regulatory limits for public exposure in Oregon and other states with limits. As long as cardiac pacemaker wearers are discouraged from using the right-of-way, the field levels meet the guidelines for exposure established by ACGIH and ICNIRP.

Short-term effects from transmission-line fields are well understood and can be mitigated. Nuisance shocks arising from electric-field induced currents and voltages could be perceivable on the right-of-way of the proposed line. BPA will ground permanent conducting objects during and after construction to mitigate against such occurrences. Since the fields from the proposed line are less than those from the existing line on the corridor, the potential for such effects could be reduced.

Corona-generated audible noise from the line would be less than from the existing 230-kV transmission lines on the corridor. Audible noise levels would be in compliance with noise regulations in Oregon and would be below levels specified in EPA guidelines.

Corona-generated electromagnetic interference from the proposed line would be less than that from the existing 230-kV line on the corridor and would remain below limits identified as acceptable. In the unlikely event that legitimate complaints arise, BPA has a mitigation program to identify and correct reception problems.

## List of References Cited

- ACGIH (American Conference of Governmental Industrial Hygienists). 2000. 2000 TLVs and BEIs: Threshold Limit Values for Chemical Substances and Physical Agents and Biological Exposure Indices. American Conference of Governmental Industrial Hygienists, Cincinnati. 192 pages.
- Baishiki, R.S.; Johnson, G.B.; Zaffanella, L.E.; Bracken, T.D.; Sussman, S.S.; Rauch, G.B.; and Silva, J.M. 1990. Studies of Power System Magnetic Fields: Characterization of Sources in Residential Environments, Measurement of Exposure, Influence On Computer Screens. (36-104) CIGRE, Paris, France. 10 pages.
- Banfai, B.; Karady, G.G.; Kim, C.J.; and Maracas, K.B. 2000. Magnetic field effects on CRT computer monitors. *IEEE Trans. on Power Delivery* 15, 307-312.
- Bassen, H.; Casamento, J.; and Crawl, B. 1991. Reduction of electric and magnetic field emissions from electric blankets (Meeting abstract). *In: Bioelectromagnetics Society, 13th Annual Meeting, 23-27 June, Salt Lake City. Bioelectromagnetics Society, New York, 20.*
- Bowman, J.D.; Garabrant, D.H.; Sobel, E.; and Peters, J.M. June 1988. Exposures to Extremely Low Frequency (ELF) Electromagnetic Fields in Occupations With Elevated Leukemia Rates. *Applied Industrial Hygienics*, 3(6, June):189-194.
- Bracken, T.D. 1987. Audible Noise from High Voltage Transmission Facilities. A Briefing Paper Prepared for State of Florida Department of Environmental Regulation. (DER Contract No. SP122) State of Florida Department of Environmental Regulation.
- Bracken, T.D. 1990. The EMDEX Project: Technology Transfer and Occupational Measurements, Volumes 1-3 Interim Report. EPRI Report EN-7048. (EPRI EN-7048) Electric Power Research Institute, Palo Alto, CA.
- Chartier, V.L. April 1983. Empirical Expressions for Calculating High Voltage Transmission Corona Phenomena, First Annual Seminar Technical Career Program for Professional Engineers. Bonneville Power Administration, Portland, Oregon. April 1983, 75-82.
- Chartier, V.L.; and Stearns, R.D. January 1981. Formulas for Predicting Audible Noise from Overhead High Voltage AC and DC Lines. *IEEE Transactions on Power Apparatus and Systems*, PAS-100(No. 1, January 1981):121-129.
- Dabkowski, J.; and Taflove, A. May/June 1979. Prediction Method for Buried Pipeline Voltages Due to 60 Hz AC Inductive Coupling. Part II: Field Test Verification. *IEEE Transactions on Power Apparatus and Systems*, PAS-98(3, May/June):788-794.
- Deno, D.W.; and Zaffanella, L. 1982. Field effects of overhead transmission lines and stations. Chap. 8. *In: Transmission Line Reference Book: 345 KV and Above. Second ed. (Ed: LaForest, J.J.). Electric Power Research Institute, Palo Alto, CA, 329-419.*
- EPA (Environmental Protection Agency). July 1973. Public Health and Welfare Criteria for Noise. (No. 500/9-73-002, July 27, 1973.) U.S. Environmental Protection Agency, Washington, D.C.

- EPA. 1974. Information On Levels of Environmental Noise Requisite to Protect Public Health and Welfare With an Adequate Margin of Safety. (No. PB-239 429.) U.S. Environmental Protection Agency, Washington, D.C.
- EPA. 1978. Protective Noise Levels. Condensed Version of EPA Levels Document. (No. PB82-138827) U.S Environmental Protection Agency, Washington, DC.
- FCC (Federal Communications Commission). 1988. Federal Communications Commission Rules and Regulations. 10-1-88 ed. Vol. II part 15, 47 CFR, Ch. 1.
- Florig, H.K.; and Hoburg, J.F. 1988. Electric and Magnetic Field Exposure Associated With Electric Blankets. Project Resume. Contractor's Review. U.S. Department of Energy/Electric Power Research Institute.
- Florig, H.K.; Hoburg, J.F.; and Morgan, M.G. April 1987. Electric Field Exposure from Electric Blankets. IEEE Transactions on Power Delivery, PWRD-2(2, April):527-536.
- Gauger, J. September 1985. Household Appliance Magnetic Field Survey. IEEE Transactions on Power Apparatus and Systems, 104(9, September):2436-2445.
- Harvey, S.M. 1983. Analysis of operator exposure to electric fields from video display units. Chap. 2. In Video Display Units--Characterization of Electric and Magnetic Fields. (Ontario Hydro Research Division Report # 83-503-K) (Ed: Walsh, M.L.). Ontario Hydro, Toronto, 31-56.
- Heroux, P. 1987. 60-Hz Electric and Magnetic Fields Generated By a Distribution Network. Bioelectromagnetics, 8(2):135-148.
- ICNIRP (International Committee on Non-ionizing Radiation Protection). April 1998. Guidelines for Limiting Exposure to Time-Varying Electric, Magnetic, and Electromagnetic Fields (Up to 300 GHz). Health Physics, 74(4, April):1-32.
- IEEE (Institute of Electrical and Electronics Engineers, Inc.). 1978. Electric and Magnetic Field Coupling from High Voltage AC Power Transmission Lines -- Classification of Short-Term Effects On People. IEEE Transactions on Power Apparatus and Systems, PAS-97:2243-2252.
- IEEE. 1987. IEEE Standard Procedures for Measurement of Power Frequency Electric and Magnetic Fields from AC Power Lines. ANSI/IEEE Std. 644-1987, New York, NY.
- IEEE. 1990. National Electrical Safety Code. 1990 ed. Institute of Electrical and Electronics Engineers, Inc., New York, NY. 432 pages.
- IEEE Committee Report. March/April 1971. Radio Noise Design Guide for High Voltage Transmission Lines. IEEE Transactions on Power Apparatus and Systems, PAS-90(No. 2, March/April):833-842.
- IEEE Committee Report. October 1982. A Comparison of Methods for Calculating Audible Noise of High Voltage Transmission Lines. IEEE Transactions on Power Apparatus and Systems, 101(10, October):4090-4099.
- ITT Research Institute. 1984. Representative Electromagnetic Field Intensities Near the Clam Lake (WI) and Republic (MI) ELF Facilities. Report Prepared for Naval Electronics Systems



- Command, PME 110 E Washington, D.C. 20360. (Under contract N00039-84-C0070.) ITT Research Institute, Chicago, IL. 60 pages.
- Jaffa, K.C.; and Stewart, J.B. March 1981. Magnetic Field Induction from Overhead Transmission and Distribution Power Lines On Buried Irrigation Pipelines. *IEEE Transactions on Power Apparatus and Systems*, PAS-100(3, March):990-1000.
- Keeseey, J.C.; and Letcher, F.S. 1969. Minimum Thresholds for Physiological Responses to Flow of Alternating Electric Current Through the Human Body At Power-Transmission Frequencies. (Report No. 1) Naval Medical Research Institute, Project MR 005.08-0030B, Bethesda, MD. 25 pages.
- Loftness, M.O.; Chartier, V.L.; and Reiner, G.L. 1981. EMI Correction Techniques for Transmission Line Corona. (August 18-20, 1981, pp. 351-361.) Proceedings of the 1981 IEEE International Symposium on Electromagnetic Compatibility, Boulder, CO.
- Maddock, B.J. September 1992. Guidelines and Standards for Exposure to Electric and Magnetic Fields At Power Frequencies. (Panel 2-05, CIGRE meeting August 30-September 5, 1992) CIGRE, Paris.
- Olsen, R.G.; Schennum, S.D.; and Chartier, V.L. April 1992. Comparison of Several Methods for Calculating Power Line Electromagnetic Interference Levels and Calibration With Long Term Data. *IEEE Transactions on Power Delivery*, 7(April, 1992):903-913.
- Oregon, State of. 1980. Oregon Administrative Rules Chapter 345, Division 80. Energy Facility Siting Council standards relating to public health and safety, 934-80-055.
- Perry, D. 1982. Sound Level Limits from BPA Facilities. BPA memorandum, May 26, 1982; Department of Environmental Quality, Noise Control Regulations, Chapter 340, Oregon Administrative Rules, Division 35, March 1, 1978.
- Reilly, J.P. 1979. Electric Field Induction on Long Objects—A Methodology for Transmission Line Impact Studies. *IEEE Transactions on Power Apparatus and Systems*, PAS-98(6, Nov/Dec):1841-1852.
- Sheppard, A.R.; and Eisenbud, M. 1977. Biological Effects of Electric and Magnetic Fields of Extremely Low Frequency. New York University Press, New York.
- Silva, M.; Hummon, N.; Rutter, D.; and Hooper, C. 1989. Power Frequency Magnetic Fields in the Home. *IEEE Transactions on Power Delivery*, 4:465-478.
- Stoppa, G.J.; and Janischewskyj, W. 1979. Epidemiological Study of Workers Maintaining HV Equipment and Transmission Lines in Ontario. (Canadian Electrical Association Research Report) Canadian Electrical Association, Montreal. 82 pages.
- Taflove, A.; and Dabkowski, J. May/June 1979. Prediction Method for Buried Pipeline Voltages Due to 60 Hz AC Inductive Coupling. Part I: Analysis. *IEEE Transactions on Power Apparatus and Systems*, PAS-98(3, May/June):780-787.

- TDHS Report. March 1989. EMF Rule Becomes Law; Hillsborough County Commission Challenges. Transmission/Distribution Health & Safety Report, 7(9, 31 March):1-3.
- TDHS Report. August 1990. Updates: New York. Transmission/Distribution Health & Safety Report, 8(7, 31 August):4.
- USDOE (U.S. Department of Energy), Bonneville Power Administration. March 1977. A Practical Handbook for the Location, Prevention and Correction of Television Interference from Overhead Power Lines. Portland, OR.
- USDOE, Bonneville Power Administration. May 1980. A Practical Handbook for the Correction of Radio Interference from Overhead Powerlines and Facilities. (May 1980.) Portland, OR.
- USDOE, Bonneville Power Administration. 1995. Living and Working Around High-Voltage Power Lines. (DOE/BP-799). Portland, OR. 9 pages.
- USDOE, Bonneville Power Administration. 1996. Electrical and Biological Effects of Transmission Lines: A Review. (DOE/BP 2938 December 1996 1M) Portland, OR.
- USDOE, Bonneville Power Administration. undated. "Corona and Field Effects" Computer Program (Public Domain Software). Bonneville Power Administration, P.O. Box 491-ELE, Vancouver, WA 98666.
- Zaffanella, L.E. 1993. Survey of Residential Magnetic Field Sources. Vol. 1: Goals, results, and conclusions. (EPRI TR-102759-V1, Project 3335-02) Electric Power Research Institute, Palo Alto, CA.
- Zaffanella, L.E.; and Kalton, G.W. 1998. Survey of personal magnetic field exposure, Phase II: 1000-person survey. Interim Report. EMF RAPID Program Engineering Project #6. Eneritech Consultants, Lee, MA.

## **List of Preparers**

T. Dan Bracken was the principal author of this report. He received a B.S. degree in physics from Dartmouth College and M.S. and Ph.D. degrees in physics from Stanford University. Dr. Bracken has been involved with research on and characterization of electric- and magnetic-field effects from transmission lines for over 27 years, first as a physicist with the Bonneville Power Administration (BPA) (1973 - 1980) and since then as a consultant. His firm, T. Dan Bracken, Inc., offers technical expertise in areas of electric- and magnetic-field measurements, instrumentation, environmental effects of transmission lines, exposure assessment and project management. Joseph Dudman of T. Dan Bracken, Inc., provided data entry, graphics, and clerical support in the preparation of the report.

Judith H. Montgomery of Judith H. Montgomery/Communications served as technical editor for the report. She holds an A.B. degree in English literature from Brown University, 1966; and a Ph.D. degree in American literature from Syracuse University, 1971. Dr. Montgomery has provided writing, editing, and communications services to government and industry for 20 years. Her experience includes preparation of National Environmental Policy Act documents and technical papers dealing with transmission-line environmental impact assessment and other utility-related activities.

(This page intentionally left blank.)

**Table 1: Physical and electrical characteristics of Santiam - Bethel Project corridors**

	New Line	Existing Corridors	
Configuration	I	I	II
Description	Santiam - Bethel/Santiam - Chemawa 230-kV	Santiam - Chemawa 230-kV	Marion - Santiam No. 1 & No. 2 500-kV
Voltage, kV Maximum/Average <sup>1</sup>	242/235	242/235	550/540, 0/0
Peak Current, A Existing/Proposed	-/755, -/644	1043/-	-889/-992, 0/0
Electric Phasing	B C A B C A	C B A	B B A C A C
Clearance, ft. Minimum/Average <sup>1</sup>	31/43	31/43	38/47
Centerline Distance from Santiam - Bethel, ft.	-	-	125
Centerline distance to edge of right-of-way (ROW), ft.	62.5	62.5	82.5
Tower configuration	Vertical double-circuit	Horizontal	Delta double-circuit
Phase spacing, ft.	24.5H, 40.5H 18V	27H	25.5H, 36.75V
Conductor: #/Diameter, in.	1/1.600	1/1.100	3/1.302

<sup>1</sup> Average voltage and average clearance used for corona calculations.

**Table 2: Possible corridors for Santiam - Bethel Project**

Configuration	Description of other lines in corridor with Santiam - Bethel/Santiam - Chemawa 230-kV line	Miles
I	Santiam - Bethel/Santiam - Chemawa 230-kV double-circuit line only	15.2
II	BPA Marion - Santiam 500-kV No. 1 and No. 2 double circuit line	1.5

**Table 3: Calculated electric fields for configurations of the proposed Santiam - Bethel/Santiam - Chemawa 230-kV line operated at maximum voltage.** Configurations are described in Tables 1 and 2.

a) **Configuration I: Santiam - Bethel/Santiam - Chemawa 230-kV line only**

Configuration	Proposed I		Existing	
ROW width, ft. (m)	125 (38)		125 (38)	
Line	Santiam - Bethel/Santiam - Chemawa 230-kV		Santiam - Chemawa 230-kV	
Clearance	Min.	Avg.	Min.	Avg.
Peak field, kV/m	2.5	1.5	3.0	1.8
Edge of ROW, kV/m	0.3	0.4	1.3	1.1

b) **Configuration II: Santiam - Bethel/Santiam - Chemawa 230-kV and Marion - Santiam 500-kV No. 1 and No. 2 lines**

Configuration	Proposed II				Existing			
ROW width, ft. (m)	270 (82)				270 (82)			
Line	Santiam - Bethel/ Santiam - Chemawa 230-kV		Marion - Santiam No. 1 and No. 2 500-kV		Santiam - Chemawa 230-kV		Marion - Santiam No. 1 and No. 2 500-kV	
Clearance	Min.	Avg.	Min.	Avg.	Min.	Avg.	Min.	Avg.
Peak field, kV/m	2.4	1.4	8.1	4.5	3.0	1.8	8.1	4.5
Edge of ROW, kV/m	0.3	0.3	2.5	2.6	1.3	1.1	2.5	2.6

**Table 4: Calculated magnetic fields for configurations of the proposed Santiam - Bethel/Santiam - Chemawa 230-kV line operated at maximum current.** Configurations are described in Tables 1 and 2.

a) **Configuration I: Santiam - Bethel/Santiam - Chemawa 230-kV line only**

Configuration	Proposed I		Existing	
ROW width, ft. (m)	125 (38)		125 (38)	
Line	Santiam - Bethel/Santiam - Chemawa 230-kV		Santiam - Chemawa 230-kV	
Clearance	Min.	Avg.	Min.	Avg.
Peak field, mG	87	50	218	139
Edge of ROW, mG	26	24	78	62

b) **Configuration II: Santiam - Bethel/Santiam - Chemawa 230-kV and Marion - Santiam 500-kV No. 1 and No. 2 lines**

Configuration	Proposed II				Existing			
ROW width, ft. (m)	270 (82)				270 (82)			
Line	Santiam - Bethel/ Santiam - Chemawa 230-kV		Marion - Santiam No. 1 and No. 2 500-kV		Santiam - Chemawa 230-kV		Marion - Santiam No. 1 and No. 2 500-kV	
Clearance	Min.	Avg.	Min.	Avg.	Min.	Avg.	Min.	Avg.
Peak field, mG	94	58	130	67	211	135	108	57
Edge of ROW, kV/m	29	24	52	39	80	65	50	38

**Table 5: States with transmission-line field limits**

STATE AGENCY	WITHIN RIGHT-OF-WAY	AT EDGE OF RIGHT-OF-WAY	COMMENTS
<b>a. 60-Hz ELECTRIC FIELD LIMIT, kV/m</b>			
Florida Department of Environmental Regulation	8 ( 230 kV) 10 (500 kV)	2	Codified regulation, adopted after a public rulemaking hearing in 1989.
Minnesota Environmental Quality Board	8	–	12-kV/m limit on the High-Voltage Direct Current (HVDC) nominal electric field.
Montana Board of Natural Resources and Conservation	7 <sup>1</sup>	1 <sup>2</sup>	Codified regulation, adopted after a public rulemaking hearing in 1984.
New Jersey Department of Environmental Protection	–	3	Used only as a guideline for evaluating complaints.
New York State Public Service Commission	11.8 (7,11) <sup>1</sup>	1.6	Explicitly implemented in terms of a specified right-of-way width.
Oregon Facility Siting Council	9	–	Codified regulation, adopted after a public rulemaking hearing in 1980.
<b>b. 60-Hz MAGNETIC FIELD LIMIT, mG</b>			
Florida Department of Environmental Regulation	–	150 ( 230 kV) 200 (500 kV)	Codified regulations, adopted after a public rulemaking hearing in 1989.
New York State Public Service Commission	–	200	Adopted August 29, 1990.

- 1 At road crossings
- 2 Landowner may waive limit

Sources: TDHS Report, 1989;TDHS Report, 1990



**Table 6: Common noise levels**

Sound Level, dBA	Noise Source or Effect
128	Threshold of pain
108	Rock-and-roll band
80	Truck at 50 ft. (15.2 m)
70	Gas lawnmower at 100 ft. (30 m)
60	Normal conversation indoors
50	Moderate rainfall on foliage
50	Edge of 500-kV right-of-way during rain
40	Refrigerator
25	Bedroom at night
0	Hearing threshold

Adapted from: USDOE, 1996.

**Table 7: Typical sound attenuation (in decibels) provided by buildings**

	Windows opened	Windows closed
<b>Warm climate</b>	12	24
<b>Cold climate</b>	17	24

Source: EPA, 1978.

**Table 8: Predicted foul-weather audible noise (AN) levels at edge of right-of-way (ROW) for proposed Santiam - Bethel/Santiam - Chemawa 230-kV line.** AN levels expressed in decibels on the A-weighted scale (dBA). L<sub>50</sub> and L<sub>5</sub> denote the levels exceeded 50 and 5 percent of the time, respectively. For the parallel-line configurations<sup>1</sup>, the AN level at the edge of the proposed Santiam - Bethel ROW is given first.

Configuration <sup>1</sup>	Foul-weather AN					
	Proposed			Existing		
	ROW ft. (m)	L <sub>50</sub> , dBA	L <sub>5</sub> , dBA	ROW ft. (m)	L <sub>50</sub> , dBA	L <sub>5</sub> , dBA
I	125 (38)	39	43	125 (38)	41	44
II	270 (82)	47, 52	51, 55	270 (82)	47, 52	51, 55

1 Configurations are described in Tables 1 and 2.

**Table 9: Predicted fair-weather radio interference (RI) levels at 100 feet (30.5 m) from the outside conductor of the proposed Santiam - Bethel/Santiam - Chemawa 230-kV line.** RI levels given in decibels above 1 microvolt/meter (dBμV/m) at 1.0 MHz. L<sub>50</sub> denotes level exceeded 50 percent of the time. For the parallel-line configurations the RI level on the side of the proposed Santiam - Bethel ROW is given first.

Configuration <sup>1</sup>	Fair-weather RI	
	Proposed	Existing
	L <sub>50</sub> , dBμV/m	L <sub>50</sub> , dBμV/m
I	26	28
II	30, 41	30, 41

1 Configurations are described in Tables 1 and 2.

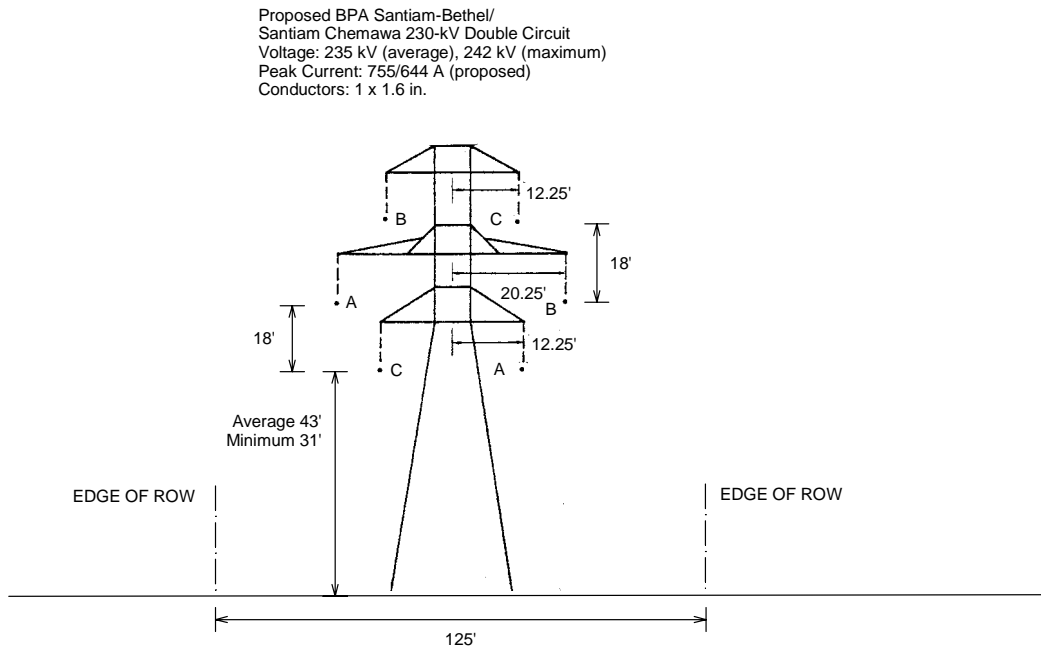
**Table 10: Predicted maximum foul-weather television interference (TVI) levels predicted at 100 feet (30.5 m) from the outside conductor of the proposed Santiam - Bethel/Santiam - Chemawa 230-kV line.** TVI levels given in decibels above 1 microvolt/meter (dB $\mu$ V/m) at 75 MHz. For the parallel-line configurations, the TVI level on the side of the proposed Santiam - Bethel ROW is given first.

<b>Configuration<sup>1</sup></b>	<b>Foul-weather TVI</b>	
	<b>Proposed</b>	<b>Existing</b>
	<b>L<sub>5</sub> (foul), dB<math>\mu</math>V/m</b>	<b>L<sub>5</sub> (foul), dB<math>\mu</math>V/m</b>
<b>I</b>	10	15
<b>II</b>	12, 27	15, 27

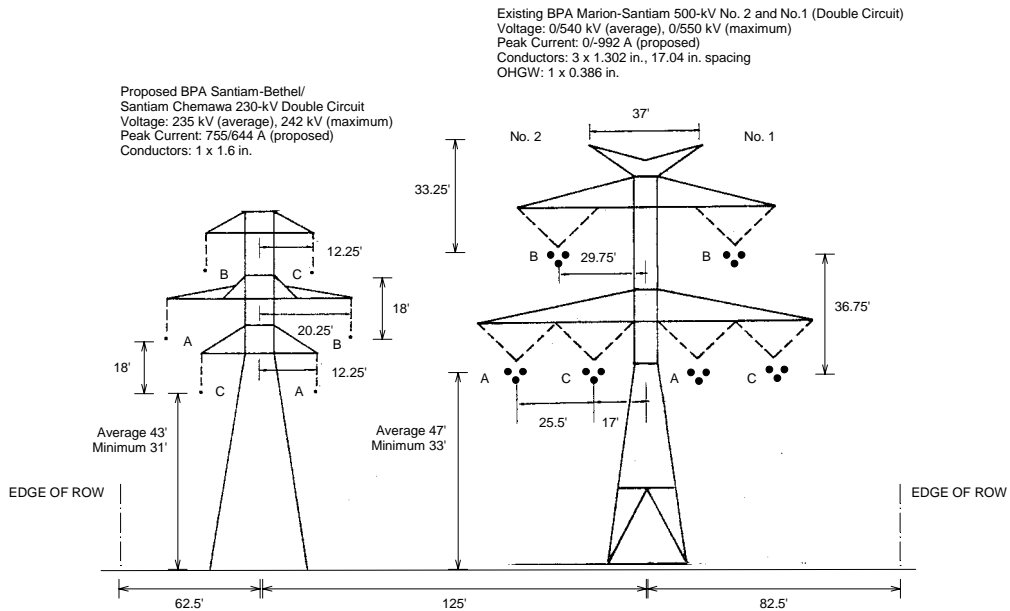
1 Configurations are described in detail in Tables 1 and 2.

**Figure 1: Configurations for proposed Santiam - Bethel/Santiam - Chemawa 230-kV line: a) proposed line with no parallel lines ( Configuration I); and b) proposed line with parallel 500-kV line (Configuration II).**

a) Proposed line with no parallel lines (Configuration I) (not to scale)

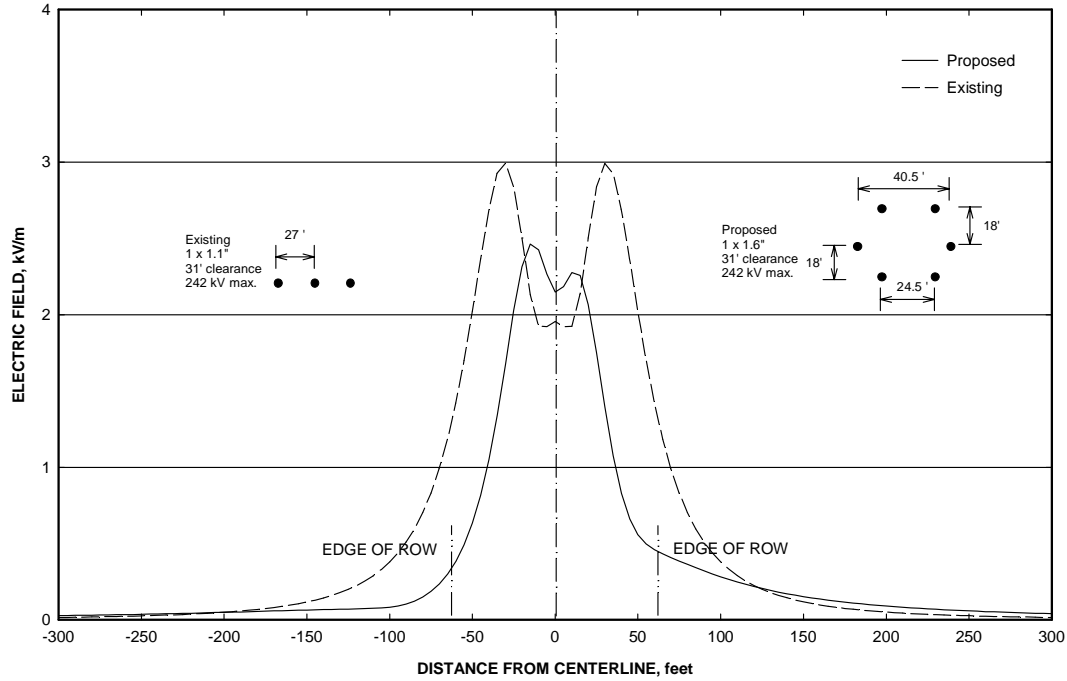


b) Proposed line with parallel 500-kV line (Configuration II) (not to scale)

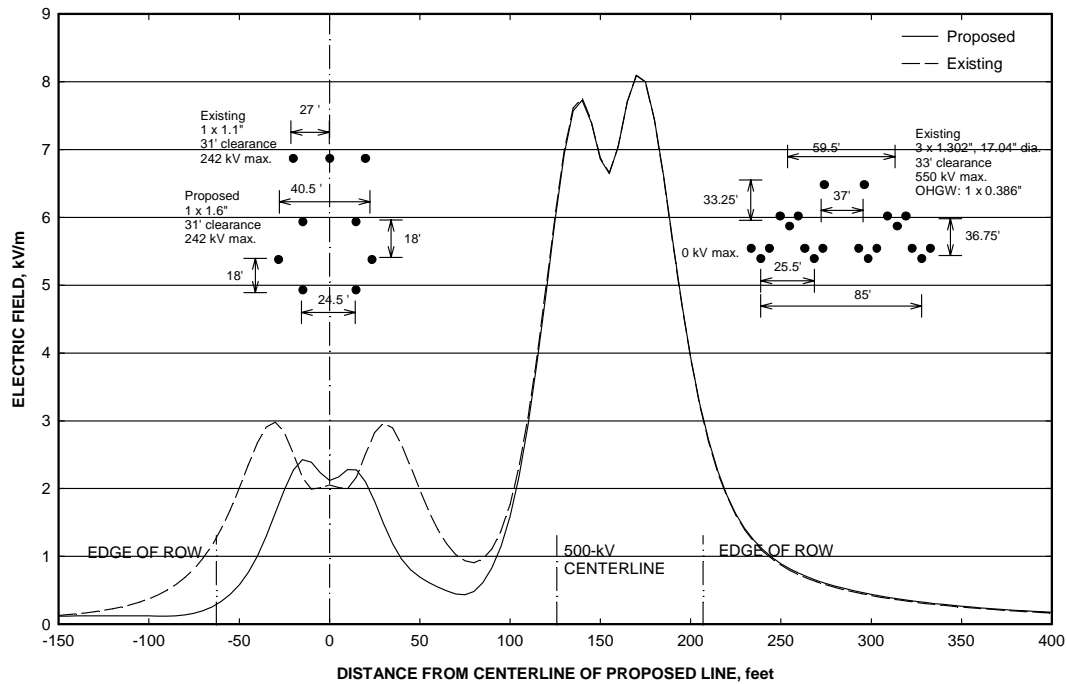


**Figure 2: Electric-field profiles for configurations of proposed Santiam - Bethel/Santiam - Chemawa 230-kV line: a) proposed line with no parallel line (Configuration I); and b) proposed line with parallel 500-kV line (Configuration II). Fields for maximum voltage and minimum clearances are shown.**

a) Proposed line with no parallel line (Configuration I).

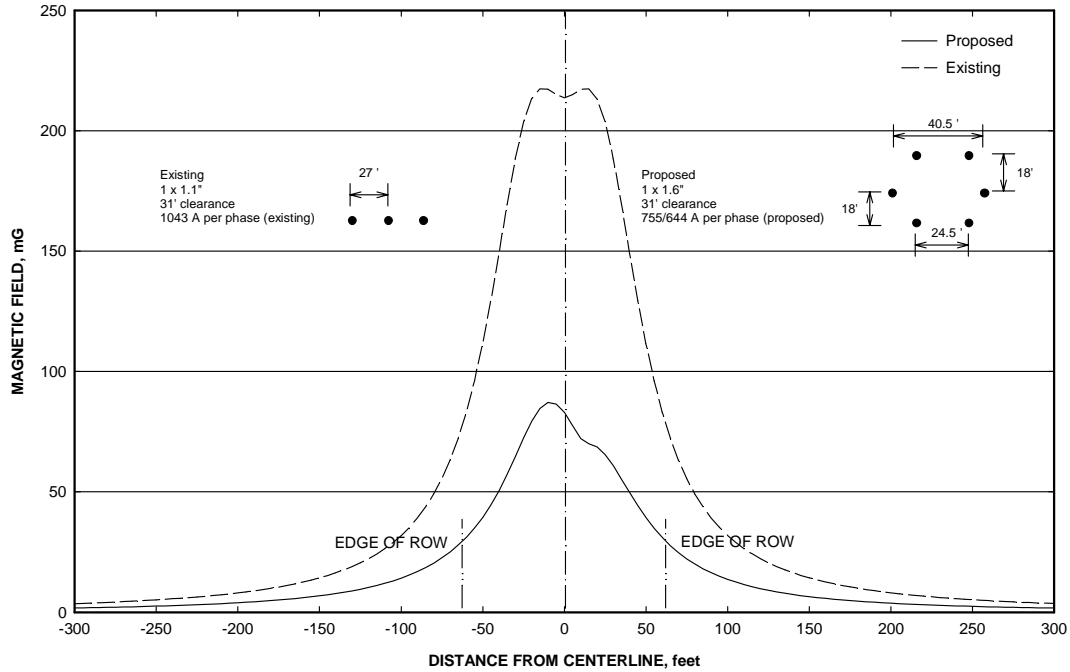


b) Proposed line with parallel 500-kV line (Configuration II)

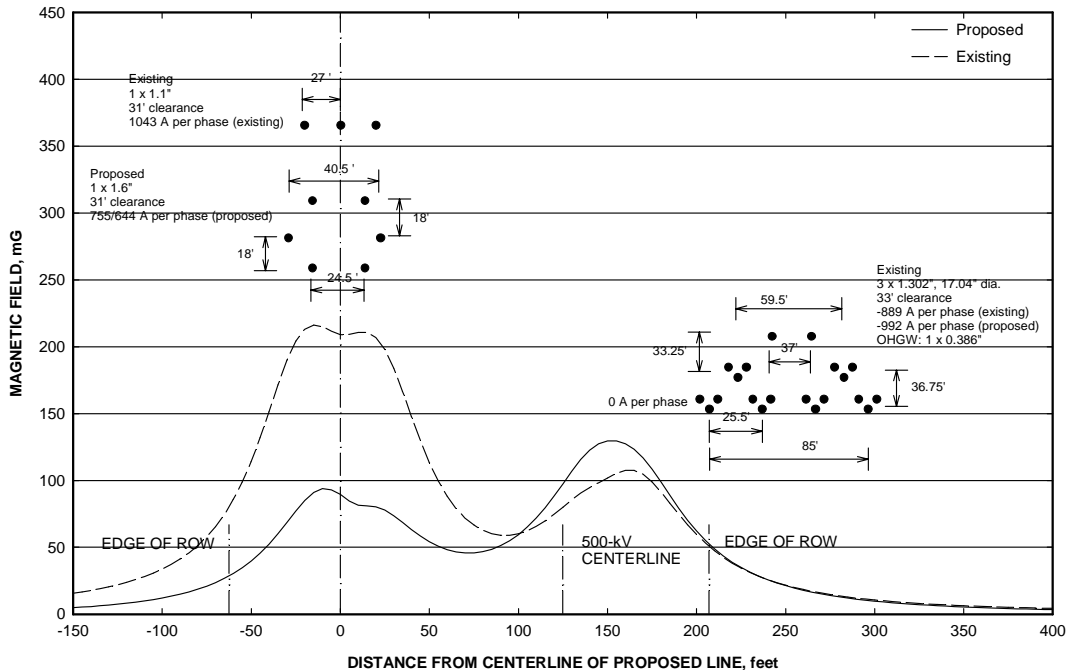


**Figure 3: Magnetic-field profiles for configurations of the proposed Santiam - Bethel/Santiam - Chemawa 230-kV line for maximum current conditions: a) proposed line with no parallel line (Configuration I); and b) proposed line with parallel 500-kV line (Configuration II).**

a) Proposed line with no parallel line (Configuration I)



b) Proposed line with parallel 500-kV line (Configuration II).



**SANTIAM-BETHEL TRANSMISSION PROJECT**

**APPENDIX B:**

**ASSESSMENT OF RESEARCH REGARDING EMF AND  
HEALTH AND ENVIRONMENTAL EFFECTS**

June 2001

Prepared by

**Exponent™**

and

**T. Dan Bracken, Inc.**

for

**Bonneville Power Administration**





## **Table of Contents**

1.0	Introduction .....	1
2.0	Health .....	1
2.1	The NIEHS Report and Research Program.....	1
2.2	Update of Research Related to Cancer.....	2
2.2.1	Epidemiology Studies of Children .....	2
2.2.2	Epidemiology Studies of Adults .....	5
2.2.3	Laboratory Studies of EMF.....	6
2.2.4	Summary Regarding Cancer .....	7
2.3	Research Related to Reproduction .....	7
2.4	Other Recent Reviews by Scientific Advisory Groups .....	7
2.4.1	National Radiological Protection Board of Great Britain (NRPB) Advisory Group on Non-Ionising Radiation .....	8
2.4.2	Health Council of the Netherlands.....	8
2.4.3	Institution of Electrical Engineers (IEE) of Great Britain.....	9
3.0	Ecological Research.....	9
3.1	Fauna.....	9
3.2	Flora .....	11
3.3	Summary .....	11
	LIST OF REFERENCES .....	12
	LIST OF PREPARERS .....	17



# **APPENDIX B: ASSESSMENT OF RESEARCH REGARDING EMF AND HEALTH AND ENVIRONMENTAL EFFECTS**

## **1.0 Introduction**

Over the last 20 years, research has been conducted in the United States (U.S.) and around the world to examine whether exposures to electric and magnetic fields (EMF) at 50/60 hertz (Hz) from electric power lines are a cause of cancer, or adversely affect human health. The research included epidemiology studies that suggested a link with childhood for some types of exposures, as well as other epidemiology studies that did not; it also included lifetime animal studies, which showed no evidence of adverse health effects. Comprehensive reviews of the research conducted by governmental and scientific agencies in the U.S. and in the United Kingdom (UK) had examined the research, and did not find a basis for imposing additional restrictions (NIEHS, 1999; IEE, 2000).

The Bonneville Power Administration (BPA) requested that Exponent update the BPA on research on EMF and health and in relation to exposures that might occur near the Bethel-Santiam Transmission Project.

This update concentrates on recent major research studies to explain how they contribute to the assessment of effects of EMF on health (Section 2). The focus is on both epidemiologic and laboratory research, because these research approaches provide different and complementary information for determining whether an environmental exposure can affect human health. Section 3, Ecological Research, reviews studies of potential effects of EMF on plants and animals in the natural environment. No additional studies of environmental effects were found in our search of the scientific literature through May 2001.

## **2.0 Health**

### **2.1 The NIEHS Report and Research Program**

In 1998, the NIEHS completed a comprehensive review of the scientific research on health effects of EMF. The NIEHS had been managing a research program that Congress funded in 1996, in response to questions regarding exposure to EMF from power sources. The program was known as the RAPID Program (Research and Public Information Dissemination Program). The NIEHS convened a panel of scientists (the “Working Group”) to review and evaluate the RAPID Program research and other research. Their report, *Assessment of Health Effects from Exposure to Power-Line Frequency Electric and Magnetic Fields*, was completed in July 1998 (NIEHS, 1998).

The director of the NIEHS prepared a health risk assessment of EMF and submitted his report to Congress in June 1999 (NIEHS, 1999). Experts at NIEHS, who had considered the previous Working Group report, reports from four technical workshops, and research that became available after June 1998, concluded as follows:

The scientific evidence suggesting that ELF-EMF [extremely low frequency-electric and magnetic field] exposures pose any health risk is weak. The strongest evidence for health

effects comes from associations observed in human populations with two forms of cancer: childhood leukemia and chronic lymphocytic leukemia in occupationally exposed adults. . . . In contrast, the mechanistic studies and animal toxicology literature fail to demonstrate any consistent pattern . . . . No indication of increased leukemias in experimental animals has been observed. . . . The lack of consistent, positive findings in animal or mechanistic studies weakens the belief that this association is actually due to ELF-EMF, but it cannot completely discount the epidemiology findings. . . . The NIEHS does not believe that other cancers or other non-cancer health outcomes provide sufficient evidence of a risk to currently warrant concern (pp. 9-10).

Although the results of the RAPID research are described in some detail in the 1998 report, many of the studies had not been published in the peer-reviewed literature. Recognizing the need to have these results reviewed and considered for publication, the NIEHS arranged for a special edition of the journal *Radiation Research* (*Radiation Research*, 153(5), 2000) to be devoted to this topic.<sup>1</sup>

## **2.2 Update of Research Related to Cancer**

This update includes studies of residential or occupational exposures to EMF and leukemia that became available this year (2001), including several reports from the California Department of Health Services. That Department conducted a workshop in 1999 to discuss epidemiologic research on EMF and health. The reports presented at this workshop were published in January 2001 as a supplement to the journal, *Bioelectromagnetics*. Many of the papers were technical discussions of methodology issues in epidemiologic studies of EMF, including discussions of how better to understand the conflicting results reported in previous studies (Neutra and Del Pizzo, 2001). For example, one paper evaluated epidemiology studies to determine whether systematic errors occurred in selection of cases and controls, or measurement of exposure. Although such systematic errors, or bias, occurred in some studies, there was insufficient information to assess the effect on results (Wartenberg, 2001a). Other researchers discuss epidemiologic approaches to study how possible confounding factors, such as the age and type of home and traffic density, might affect the interpretation of studies of EMF and childhood cancer (Langholz, 2001; Reynolds et al., 2001).

For this update, we review papers from this workshop that provide new information or statistical analyses. Several of the studies are “meta-analyses,” an approach that incorporates statistical methods to analyze differences and aggregate the results of smaller studies. The section below includes a review of meta-analyses of the studies of childhood leukemia through 1999, and a meta-analysis of studies of breast cancer in adults (Erren, 2001).

### **2.2.1 Epidemiology Studies of Children**

The question of power lines and childhood cancer has been based on the assumption that the relevant exposure associated with power lines is the magnetic field, rather than the electric field. This assumption rests on the fact that electric fields are shielded from the interior of homes (where people spend the vast majority of their time) by walls and vegetation, while magnetic fields are not. The magnetic field in the vicinity of a power line results from the flow of current; higher currents result in higher levels of magnetic fields.

---

<sup>1</sup> See, for instance, the articles cited in the **List of References** under Balcer- Kubiczek, Boorman, Loberg, and Ryan.

Epidemiologic studies report results in the form of statistical associations. The term “statistical association” is used to describe the tendency of two things to be linked or to vary in the same way, such as level of exposure and occurrence of disease. However, statistical associations are not automatically an indication of cause and effect, because the interpretation of numerical information depends on the context, including (for example) the nature of what is being studied, the source of the data, how the data were collected, and the size of the study. The larger studies and more powerful studies of EMF have not reported convincing statistical associations between power lines and childhood leukemia (e.g., Linet et al., 1997; McBride et al., 1999; UKCCS, 1999). Despite the larger sample size, these studies usually had a limited number of cases exposed over 2 or 3 milligauss (mG).

### *Epidemiology studies*

The following discussion briefly describes major studies.

- A study from Germany included 502 children with leukemia and 1,289 control children (Schuz et al., 2001). Measurements of magnetic-field intensity (50 Hz) were taken for 24 hours in the child’s bedroom. The results were calculated for daytime or nighttime levels in the bedroom, rather than for the child’s overall 24-hour exposure. The authors report an association with leukemia for mean daytime magnetic-field exposures that might have been due to chance. They reported an association between mean nighttime magnetic-field levels and leukemia for the highest exposed group (4 mG or higher; 9 cases). The assessment of exposure by mean field levels in the bedroom did not link magnetic-field levels to any specific source. The authors note in their conclusions that “. . . fewer than one-third of all stronger magnetic fields were caused by high-voltage powerlines. . . .” (Schuz et al., 2001: 734).

Several aspects of the study detract from the validity of the results: the estimate included a broad margin of error because only a small number of cases was exposed at the higher levels, and many eligible cases and controls did not participate, which means that the responders may not represent the population and results could be biased. Another concern is that these magnetic field measurements were taken in 1997, long after the relevant exposure period for cases diagnosed in 1990-1994. Magnetic-field levels may have changed over time, as electricity usage changed.

- A study from British Columbia, Canada, included 462 children who had been diagnosed with leukemia and an equal number of children without leukemia for comparison (McBride et al., 1999). Magnetic-field exposure was assessed for each of the children in several ways: personal monitors were worn in a backpack for 48 hours, a monitor took measurements in the bedroom for 24 hours, the wiring outside the house was rated by potential exposure level (wire codes), and measurements were taken around the outside perimeter of the homes. (Wire codes are a method of estimating relative exposure intensity based on the configuration of the power lines.) Regardless of the method used to estimate magnetic-field exposure, the magnetic-field exposure of children who had leukemia was not greater than that of the children in the comparison group.
- A study conducted in Ontario, Canada reported on the magnetic-field exposure of a smaller group of children (Green et al., 1999a). No increased risk estimates were found with the average magnetic fields in the bedroom or the interior, or with any of the three methods of estimating exposure from wire-configuration codes. A still smaller group of 88 children with leukemia and their controls wore personal monitors to measure magnetic fields (Green et al., 1999b). Associations with magnetic fields were reported in some of the analyses, but most of the risk estimates had a broad margin of error, and major methodological problems in the study preclude any clear interpretation of the findings.

- The United Kingdom Childhood Cancer Study, the largest study to date, included a total of 1073 childhood leukemia cases (UKCCS, 1999). Exposure was assessed by spot measurements in the home (bedroom and family room) and school, and summarized by averaging these over time. No evidence was found to support the idea of an increased risk of leukemia from exposures to magnetic fields from power sources inside or outside of the home.
- The UKCCS investigators had obtained magnetic-field measurements on only a portion of the cases in their study (UKCCS, 1999). To obtain additional information, they used a method to assess exposure to magnetic fields without entering homes; they were thus able to analyze 50% more subjects (UKCCS, 2000). For all these children, they measured distances to power lines and substations. This information was used to calculate the magnetic field from these external field sources, based on power-line characteristics related to production of magnetic fields. The results of the second UKCCS study showed no evidence for an association with leukemia for magnetic fields calculated to be between 1 mG and 2 mG, 2 mG and 4 mG, or 4 mG or greater at the residence, in contrast to the weak association reported for measured fields of 4 mG or greater in the first report (UKCCS, 1999).

Researchers have proposed that the associations that are sometimes reported between childhood leukemia and power lines may be due to other factors that can confound the analysis. One example is heavy traffic, which may occur near power lines and can increase the levels of potentially carcinogenic chemicals in the area. Earlier studies had reported associations between traffic density and childhood cancer (Savitz et al., 1988). If power lines were more common in areas that had higher traffic density, then the increased air pollution might explain an association between power lines and childhood cancer. However, more recent studies seem to eliminate this possibility. In a study of 90 cases of childhood leukemia, Reynolds et al. (2001) found no evidence of an association with traffic density. In a larger study that included 986 cases of childhood leukemia, no association was found with high traffic-density exposure during pregnancy or childhood (Raaschou-Nielsen et al., 2001). In addition, no association with childhood leukemia or brain cancer was found for exposures to benzene or nitrogen dioxide. Associations were reported between Hodgkin's disease and exposure to each of these chemicals.

#### *Meta-analyses of studies of leukemia*

Recently, researchers reanalyzed the data from previous epidemiology studies of magnetic fields and childhood leukemia (Ahlbom et al., 2000; Greenland et al., 2000). The researchers pooled the data on individuals from each of the studies, creating a study with a larger number of subjects and therefore greater statistical power than any single study. A pooled analysis is preferable to other types of meta-analyses in which the results from several studies are combined from grouped data obtained from the published studies. These analyses focused on studies that assessed exposure to magnetic fields using 24-hour measurements or calculations based on the characteristics of the power lines and current load. Both Ahlbom et al. and Greenland et al. used exposure categories of <0.1 microtesla ( $\mu\text{T}$ ) (<1 mG) as a reference category. The statistical results of these analyses can be summarized as follows:

- The pooled analyses provided no indication that wire codes are more strongly associated with leukemia than measured fields.
- Pooling these data corroborates an absence of an association between childhood leukemia and magnetic fields for exposures below 0.3  $\mu\text{T}$  (3 mG).
- Pooling these data results in a statistical association with leukemia for exposures greater than 0.3 or 0.4  $\mu\text{T}$  (3-4 mG).

The authors are appropriately cautious in the interpretation of their analyses, and they clearly identify the limitations in their evaluation of the original studies. Magnetic fields above 0.3  $\mu$ T in residences are estimated to be rather rare, about 3% in the U.S. (Zaffanella, 1993). Limitations include sparse data (few cases) to adequately characterize a relationship between magnetic fields and leukemia, uncertainties related to pooling different magnetic-field measures without evidence that all of the measures are comparable, and incomplete and limited data on important confounders (other risk factors for disease that may distort the analysis) such as housing type and traffic density.

A meta-analysis of the data from epidemiologic studies of childhood leukemia studies was presented at the California Workshop and recently published (Wartenberg, 2001b). This meta-analysis did not have the advantage of obtaining and pooling the data on all of the individuals in the studies, unlike those published before it (Ahlbom et al., 2000; Greenland et al., 2000). Rather than individual data, Wartenberg (2001b) used an approach that extracted the published results, reported as grouped data from several published studies. He used 19 studies overall, after excluding 7 studies that had insufficient data on individuals or deficiencies in the exposure assessment data. He reported a weak association for a) “proximity to electrical facilities” based on wire codes or distance, and b) magnetic-field level over 2 mG, based on either calculations from wiring and loading characteristics (if available) or on spot magnetic-field measurements. The results show more cases than controls exposed to measured or calculated fields above 2 mG. The author concludes that the analysis supports an association, although the size of the effect is small to moderate, but also notes “limitations due to design, confounding, and other biases may suggest alternative interpretations” (Wartenberg, 2001b:S-100).

The results of this meta-analysis are not directly comparable to previous ones regarding fields of 3 or 4 mG because the analysis was not based on individual data. The comparison of grouped data used different exposure cut points for the analysis and different criteria for the comparison group. None of these three analyses (Ahlbom et al., 2000; Greenland et al., 2000; Wartenberg, 2001b) includes the results of the UK analysis of over 3000 cases based on calculated fields, which found no association between EMF and childhood cancer, regardless of the exposure level.

### **2.2.2 Epidemiology Studies of Adults**

Studies of adults with certain types of cancer, such as brain cancer, breast cancer, or leukemia, have reported associations with exposure to magnetic fields at residences, but results have not been consistent across studies. Contradictory results among studies argue against a conclusion that the association reflects a cause-and-effect relationship. In their assessments of risk, scientists give most weight to studies that include more people, obtain more detailed and individual exposure assessments, and/or include people who have higher exposures.

A study of 492 adult cases of brain cancer in California included measurements of magnetic fields taken in the home and at the front door, and considered the types of power-line wiring (Wrensch et al., 1999). The authors report no evidence of increased risk with higher exposures, no association with type of power line, and no link with levels measured at the front door.

A number of recent studies of breast cancer focused on electric blankets as a source of high exposure. Electric blankets are assumed to be one of the strongest sources of EMF exposure in the home. Three studies of electric blanket use found no evidence that long-term use increased the risk of breast cancer. Women who developed breast cancer reported no difference in total use of electric blankets, use in recent years, or use many years in the past:

- Gammon et al. (1998) reported that, even for those who kept the blanket on most of the time, no increase in risk was found for those who had longer duration of use (measured in months).

- A study of 608 breast cancer cases also found no evidence of increased use of electric blankets or other home appliances in cases compared to controls, and no indication of increasing risk with a longer time of use (Zheng et al., 2000).
- In a cohort of over 120,000 female nurses, data were obtained on known risk factors for breast cancer as well as electric-blanket use (Laden et al., 2000). For a large subset of this group, the questions about exposure were asked before the disease occurred, a step taken to eliminate bias in recalling exposure.

Erren (2001) reported the results of a meta-analysis of the studies of breast cancer, in which the results of 24 different studies in women were statistically aggregated. When the results of all 24 studies were pooled, including studies of workplace exposures, the estimate indicated an association between EMF and a small excess breast cancer risk. The pooled results for exposure to EMF in the vicinity of electrical facilities did not show an association with breast cancer, nor did the results for exposure to EMF from appliance use. However, the meta-analysis also showed a lack of consistency among the results of the individual studies, a broad variation in the designs, and a wide range of methods used to assess exposure. No adjustments were made to the data to give increased weight to studies based on more comprehensive exposure assessments. The author also noted that the weak statistical association might be an artifact (a result of chance or unforeseen error) rather than an indication of a cause-and-effect relationship (Erren, 2001).

### **2.2.3 Laboratory Studies of EMF**

Laboratory studies complement epidemiologic studies of people because the effects of heredity, diet, and other health-related exposures of animals can be better controlled or eliminated. The assessment of EMF and health, as for any other exposure, includes chronic, long-term studies in animals (*in vivo* studies) and studies of changes in genes or other cellular processes observed in isolated cells and tissues in the laboratory (*in vitro*).

Although the results of the RAPID Program were described in some detail in the NIEHS reports (NIEHS, 1998), many of the studies had not been published in the peer-reviewed literature. The RAPID research program included studies of four biological effects, each of which had been observed in only one laboratory. These effects are as follows: effects on gene expression, increased intracellular calcium in a human cell line, proliferation of cell colonies on agar, and increased activity of the enzyme ornithine decarboxylase (ODC). Some scientists have suggested that these biological responses are signs of possible adverse health effects of EMF. It is standard scientific procedure to attempt to replicate results in other laboratories, because artifacts and investigator error can occur in scientific investigations. Replications, often using more experiments or more rigorous protocols, help to ensure objectivity and validity. Attempts at replication can substantiate and strengthen an observation, or they may discover the underlying reason for the observed response.

Studies in the RAPID program reported no consistent biological effects of EMF exposure on gene expression, intracellular calcium concentration, growth of cell colonies on agar, or ODC activity (Boorman et al., 2000b). For example, Loberg et al. (2000) and Balcer-Kubiczek et al. (2000) studied the expression of hundreds of cancer-related genes in human mammary or leukemia cell lines. They found no increase in gene expression with increased intensity of magnetic fields. To test the experimental procedure, they used X-rays and treatments known to affect the genes. These are known as positive controls and, as expected, caused gene expression in exposed cells.



Scientists have concluded that the combined animal bioassay results provide no evidence that magnetic fields cause, enhance, or promote the development of leukemia and lymphoma, or mammary cancer (e.g., Boorman et al., 1999; McCormick et al., 1999; Boorman et al., 2000 a, b; Anderson et al., 2001).

#### **2.2.4 Summary Regarding Cancer**

Epidemiology studies do not support the idea that EMF from power lines increase the risk of cancers in adults. The latest epidemiologic studies of childhood cancer, considered in the context of the other data, provide no persuasive and consistent evidence that leukemia in children is causally associated with magnetic fields measured at the home, calculated based on distance and current loading, or with wire codes. Recent meta-analyses reported no association between childhood cancer and magnetic fields below 2 or 3 mG. Although some association was reported for fields above this level, fields at most residences are likely to be below 3 or 4 mG. The authors of each of these analyses list several biases and problems that render the data inconclusive, and prevent resolution of the inconsistencies in the epidemiologic data. For this reason, laboratory studies can provide important complementary information. Large, well-conducted animal studies provide no convincing evidence that exposure increases the risk of cancer. Animal studies, and studies of initiation and promotion, provide no basis to conclude that EMF increases leukemia, lymphoma, breast, brain, or any other type of cancer.

### **2.3 Research Related to Reproduction**

Previous epidemiologic studies reported no association with birth weight or fetal growth retardation after exposure to sources of relatively strong magnetic fields, such as electric blankets, or sources of typically weaker magnetic fields such as power lines (Bracken et al., 1995; Belanger et al., 1998).

A recent epidemiology study examined miscarriages<sup>2</sup> in relation to exposures to magnetic fields from electric bed-heating (electric blankets, heated waterbeds and mattress pads), which result in higher exposures than residential fields in general (Lee et al., 2000). The researchers assessed exposure prior to the birth (a prospective study) and included information to control for potential confounding factors (other exposures and conditions that affect the risk of miscarriage). This study had a large number of cases and high participation rates. Miscarriage rates were lower among users of electric bed heating.

Studies of laboratory animals exposed to pure 60-Hz fields have shown no increase in birth defects, no multigenerational effects, and no changes that would indicate an increase in miscarriage or loss of fertility (e.g., Ryan et al., 1999; Ryan et al., 2000). Exposed and unexposed litters were no different in the amount of fetal loss and the number and type of birth defects, indicating no reproductive effect of EMF.

In summary, the recent evidence from epidemiology and laboratory studies provides no indication that exposure to power-frequency EMF has an adverse effect on reproduction, pregnancy, or growth and development of the embryo. The results of these recent studies are consistent with the conclusions of the NIEHS.

### **2.4 Other Recent Reviews by Scientific Advisory Groups**

Reviews of the scientific research regarding EMF and health by Health Council of the Netherlands and the Institute of Electrical Engineers of the UK were published in 2000. The National Radiological

---

<sup>2</sup> The medical term for miscarriage is spontaneous abortion.

Protection Board of Great Britain (NRPB) Advisory Group on Non-Ionizing Radiation published the most recent review in 2001. This review includes research published in 2000, and includes the most comprehensive discussion of the individual research studies.

#### **2.4.1 National Radiological Protection Board of Great Britain (NRPB) Advisory Group on Non-Ionising Radiation**

The conclusions from the report prepared by the NRPB's Advisory Group on Non-Ionising Radiation (AGNIR) on extremely low frequency (ELF) EMF and the risk of cancer are consistent with previous reviews. Members from universities, medical schools, and cancer research institutes reviewed the reports of experimental and epidemiological studies, including reports in the literature in 2000. Their general conclusions are as follows:

Laboratory experiments have provided no good evidence that extremely low frequency electromagnetic fields are capable of producing cancer, nor do human epidemiological studies suggest that they cause cancer in general. There is, however, some epidemiological evidence that prolonged exposure to higher levels of power frequency magnetic fields is associated with a small risk of leukaemia in children. In practice, such levels of exposure are seldom encountered by the general public in the UK [or in the US] (NRPB, 2001: 164).

The group further recognizes that the scientific evidence suggesting that exposure to power-frequency electromagnetic fields poses an increased risk of cancer is very weak. Virtually all of the cellular, animal, and human laboratory evidence provides no support for an increased risk of cancer incidence following such exposure to power frequencies, although sporadic positive findings have been reported. In addition, the epidemiological evidence is, at best, weak.

These conclusions of the Advisory Group are consistent with previous reviews by the NIEHS (1999) and the Health Council of the Netherlands (HCN, 2000). The NRPB response to the Advisory Group report states "the review of experimental studies by [the Advisory Group] AGNIR gives no clear support for a causal relationship between exposure to ELF-EMFs and cancer" (NRPB, 2001:1).

#### **2.4.2 Health Council of the Netherlands**

The Health Council of the Netherlands has prepared an update of its 1992 Advisory Report on exposure to electromagnetic fields (0 Hz to 10 MHz) (HCN, 2000). Members of the Expert Committee prepared the report. The Expert Committee based its analysis on the review and summaries of the studies provided in the NIEHS (1998) and concurred with the views of the director of the NIEHS (1999). For the update, the Committee evaluated a number of publications that appeared after these reports, e.g., McBride et al. (1999) and Green et al. (1999a), and wrote:

The committee thinks that the quality of the relevant epidemiological research has improved considerably since the publication of the advisory report in 1992. Even so, this research has not resulted in unequivocal, scientifically reliable conclusions (p. 15).

The Council emphasizes that the associations with EMF reported in epidemiologic studies are strictly statistical and do not demonstrate a cause-and-effect relationship. In their view, experimental research does not demonstrate a causal link or a mechanism to explain EMF as a cause of disease in humans. They concluded that there is no reason to recommend measures to limit residence near overhead power lines (HCN, 2000).

### **2.4.3 Institution of Electrical Engineers (IEE) of Great Britain**

One of the recent reviews was that of the Institution of Electrical Engineers (IEE) of Great Britain (IEE, 2000). In 1992, the IEE set up a Working Party whose eight members, with broad expertise in the health sciences, review the relevant scientific literature and prepare reports of their views. Their conclusion is based on recent major epidemiologic studies and the scientific literature built up over the past 20 years. In May 2000, the Working Party concluded “. . . that there is still not convincing scientific evidence showing harmful effects of low level electromagnetic fields on humans” (IEE, 2000:1).

## **3.0 Ecological Research**

Scientists have studied the effects of high-voltage transmission lines on many plant and animal species in the natural environment. In this section, we briefly review the research on the effects of EMF on ecological systems to assess the likelihood of adverse impacts. In addition to the comprehensive review of research on this topic by wildlife biologists at the BPA (Lee et al., 1996), we searched the published scientific literature for more recent studies published between 1995 and May 2001.

### **3.1 Fauna**

The habitat on the transmission-line right-of-way and surrounding area shields most wildlife from electric fields. Vegetation in the form of grasses, shrubs, and small trees largely shields small ground-dwelling species such as mice, rabbits, foxes, and snakes from electric fields. Species that live underground, such as moles, woodchucks, and worms, are further shielded from electric fields by the soil. Hence, large species such as deer and domestic livestock (e.g., sheep and cattle) have greater potential exposures to electric fields since they can stand taller than surrounding vegetation. However, the duration of exposure for deer and other large animals is likely to be limited to foraging bouts or the time it takes them to cross under the line. Furthermore, all species would be exposed to higher magnetic fields under a transmission-line than elsewhere, as the vegetation and soil do not provide shielding from this aspect of the transmission-line electrical environment.

Field studies have been performed in which the behavior of large mammals in the vicinity of high-voltage transmission lines was monitored. No effects of electric or magnetic fields were evident in two studies from the northern United States on big game species, such as deer and elk, exposed to a 500-kV transmission line (Goodwin 1975; Picton et al., 1985). In such studies, a possible confounding factor is audible noise. Audible noise associated with high-voltage power transmission lines (with voltages greater than 110-kV) is due to corona. Audible noise generated by transmission lines reaches its highest levels in inclement weather (rain or snow).

Much larger populations of animals that might spend time near a transmission line are livestock that graze under or near transmission lines. To provide a more sensitive and reliable test for adverse effects than informal observation, scientists have studied animals continuously exposed to fields from the lines in relatively controlled conditions. For example, grazing animals such as cows and sheep have been exposed to high-voltage transmission lines and their reproductive performance examined (Lee et al., 1996). In some studies, the effects of exposure over one or more successive breedings were examined (Angell et al., 1990). Compared to unexposed animals in a similar environment, it was found that the exposure did not affect reproductive functions or pregnancy of cows (Algers and Hennichs, 1985; Algers and Hultgren, 1987).

A group of investigators from Oregon State University, Portland State University, and other academic centers evaluated the effects of long-term exposure to EMF from a 500-kV transmission line operated by

BPA on various cellular aspects of immune response, including the production of proteins by leukocytes (IL-1 and IL-2) of sheep. In previous unpublished reports, the researchers found differences in IL-1 activity between exposed and control groups. However, in their most recent replication, the authors found no evidence of differences in these measures of immune function. The sheep were exposed to 27 months of continuous exposure to EMF, a period of exposure much greater than the short, intermittent exposures of sheep grazing under transmission lines. Mean exposures of magnetic and electric fields were 3.5-3.8  $\mu$ T (35-38 mG) and 5.2-5.8 kV/m, respectively (Hefeneider et al., 2001).

Scientists from Illinois Institute of Technology (IIT) monitored the possible effects of electric and magnetic fields on fauna and flora in Michigan and Wisconsin from 1969 – 1997 to evaluate the effects of an above-ground, military-communications antenna operating at 76 Hz. The antenna produces EMF similar in physical characteristics to those produced by high-voltage transmission lines, but of much lower intensity. This study included embryonic development, fertility, postnatal growth, maturation, aerobic metabolism, and homing behavior, and showed no adverse impacts of ELF electric and magnetic fields on the animals (NRC, 1997).

The hormone melatonin, secreted at night by the pineal gland, plays a role in animals that are seasonal breeders. Studies in laboratory mice and rats have suggested that exposure to electric and/or magnetic fields might affect levels of the hormone melatonin, but results have not been consistent (Wilson et al., 1981; Holmberg, 1995; Kroeker et al., 1996; Vollrath et al., 1997; Huuskonen et al., 2001). However, when researchers examined sheep and cattle exposed to EMF from transmission lines exceeding 500-kV, they found no effect on the levels of the hormone melatonin in blood, weight gain, onset of puberty, or behavior in sheep and cattle (Stormshak et al., 1992; Lee et al., 1993; Lee et al., 1995; Thompson et al., 1995; Burchard et al., 1998).

Another part of the IIT study examined the effect of the antenna system fields on the growth, development, and homing behavior of birds. Studies of embryonic development (Beaver et al., 1993), fertility, postnatal growth, maturation, aerobic metabolism, and homing behavior showed no adverse impacts of ELF electric and magnetic fields on the animals (NRC, 1997). Fernie and colleagues studied the effects of continuous EMF exposure of raptors to an electric field of 10 kV/m in a controlled, laboratory setting. The exposure was designed to mimic exposure to a 765-kV transmission line. Continuous EMF exposure was found to reduce hatching success, yet increase egg size, fledging success, and embryonic development (Fernie et al., 2000). In a study of the effects on body mass and food intake of reproducing falcons, the authors found that EMF lengthened the photoperiod as a result of altered melatonin levels in the male species, yet concluded that “EMF effects on adult birds may only occur after continuous, extended exposure,” which is not likely to occur from resting on power lines (Fernie and Bird, 1999:620).

Several avian species are reported to use the earth’s magnetic field as one of the cues for navigation. It has been proposed that deposits of magnetite in specialized cells in the head are the mechanism by which the birds can detect variations in the inclination and intensity of a dc magnetic field (Kirschvink and Gould, 1981; Walcott et al., 1988). In early studies of transmission lines, it was reported that the migratory patterns of birds appeared to be altered near transmission lines (Southern, 1975; Larkin and Sutherland, 1977). However, these studies were of crude design, and Lee et al. (1996) concluded that, “During migration, birds must routinely fly over probably hundreds (or thousands) of electrical transmission and distribution lines. We are not aware of any evidence to suggest that such lines are disrupting migratory flights” (p. 4-59). No further studies on this topic were identified in the literature.

Bees, like birds, are able to detect the earth’s dc magnetic fields. They are known to use magnetite particles, which are contained in an abdominal organ, as a compass (Kirschvink and Gould, 1981). In the

laboratory, they are able to discriminate between a localized magnetic anomaly and a uniform background dc magnetic field (Walker et al., 1982; Kirschvink et al., 1992).

Greenberg et al. (1981) studied honeybee colonies placed near 765-kV transmission lines. They found that hives exposed to electric fields of 7 kV/m had decreased hive weight, abnormal amounts of propolis (a resinous material) at hive entrances, increased mortality and irritability, loss of the queen in some hives, and a decrease in the hive's overall survival compared to hives that were not exposed. Exposure to electric fields of 7-12 kV/m may induce a current or heat the interior of the hive; however, placing the hive farther from the line, shielding the hive, or using hives without metallic parts eliminates this problem. ITT studied the effects of EMF on bees exposed to the 76-Hz antenna system at lower intensities and concluded that these behavioral effects of "ELF-EMF impacts are absent or at most minimal" (NRC, 1997:102).

Reptiles and amphibians contribute to the overall functioning of the forest ecosystems. However, little research has been performed on the effects of EMF on reptiles and amphibians in their natural habitat.

### **3.2 Flora**

Numerous studies have been carried out to assess the effect of exposure of plants to transmission-line electric and magnetic fields. These studies have involved both forest species and agriculture crops. Researchers have found no adverse effects on plant responses, including seed germination, seedling emergence, seedling growth, leaf area per plant, flowering, seed production, germination of the seeds, longevity, and biomass production (Lee et al., 1996).

The only confirmed adverse effect of transmission lines on plants was reported for transmission lines with voltages above 1200-kV. For example, Douglas Fir trees planted within 15 m of the conductors were shorter than trees planted away from the line. Shorter trees are believed to result from corona-induced damage to the branch tips. Trees between 15 and 30 m away from the line suffered needle burns, but those 30 m and beyond were not affected (Rogers et al., 1984). These effects would not occur at the lower field intensities expected beyond the right-of-way of the proposed 500-kV transmission line.

### **3.3 Summary**

The habitat on the transmission-line rights-of-way and surrounding areas shield smaller animals from electric fields produced by high-voltage transmission lines; thus, vegetation easily shields small animals from electric fields. The greatest potential for larger animals to be exposed to EMF occurs when they are passing beneath the lines. Studies of animal reproductive performance, behavior, melatonin production, immune function, and navigation have found minimal or no effects of EMF. Past studies have found little effect of EMF on plants; no recent studies of plants growing near transmission lines have been performed. In summary, the literature published to date has shown little evidence of adverse effects of EMF from high-voltage transmission lines on wildlife and plants. At the field intensities associated with the proposed 230-kV transmission line, no adverse effects on wildlife or plants are expected.

## **LIST OF REFERENCES**

- Ahlbom, A.; Day, N.; Feychting, M.; Roman, E.; Skinner, J.; Dockerty, J.; Linet, M.; Michealis, J.; Olsen, J.H.; Tynes, T.; Verasalo, P.K. 2000. A pooled analysis of magnetic fields and childhood leukaemia. *British Journal of Cancer*, 83(5): 692-698.
- Algers, B.; and Hennichs, K. 1985. The effect of exposure to 400-kV transmission lines on the fertility of cows: a retrospective cohort study. *Preventive Veterinary Medicine* 3: 351-361.
- Algers, B.; and Hultgren, J. 1987. Effects of long-term exposure to a 400-kV, 50-Hz transmission line on estrous and fertility in cows. *Preventive Veterinary Medicine* 5: 21-36.
- Anderson, L.E.; Morris, J.E.; Miller, D.L.; Rafferty, C.N.; Ebi, K.L.; Sasser, L.B. 2001. Large granular lymphocytic (LGL) leukemia in rats exposed to intermittent 60 Hz magnetic fields. *Bioelectromagnetics*, 22:185-193.
- Angell, R.F.; Schott, M.R.; Raleigh, R.J.; Bracken, T.D. 1990. Effects of a high-voltage direct-current transmission line on beef cattle production. *Bioelectromagnetics*. 11(4):273-82.
- Balcer-Kubiczek, E.K.; Harrison, G.H.; Davis, C.C.; Haas, M.L.; Koffman, B.H. 2000. Expression analysis of human HL60 exposed to 60 Hz square or sine-wave magnetic fields. *Radiation Research*, 153(5): 670-678.
- Beaver, D.L.; Hill, R.W.; Lederle, P.E. 1993. Assessment of the effects of extremely low frequency electromagnetic radiation on growth and maturation in nestling tree swallows and deer mice. *Electricity and Magnetism in Biology and Medicine*. M. Blank, ed., San Francisco Press, Inc., pp. 925-926.
- Belanger, K.; Leaderer, B.; Hellenbrand, K.; Holford, T.R.; McSharry, J.; Power, M.E.; Bracken, M.B. 1998. Spontaneous abortion and exposure to electric blankets and heated water beds. *Epidemiology*, 9:36-42.
- Boorman, G.A.; Anderson, L.E.; Morris, J.E.; Sasser, L.B.; Mann, P.C.; Grumbein, S.L.; Hailey, J.R.; McNally, A.; Sills, R.C.; Haseman, J.K. 1999. Effects of 26-week magnetic field exposure in a DMBA initiation-promotion mammary glands model in Sprague-Dawley rats. *Carcinogenesis*, 20: 899-904.
- Boorman, G.A.; McCormick, D.J.; Ward, J.M.; Haseman, J.K.; Sills, R.C. 2000a. Magnetic fields and mammary cancer in rodents: A critical review and evaluation of published literature. *Radiation Research*, 153(5), Part 2: 617.
- Boorman, G.A.; Rafferty, C.N.; Ward, J.M.; Sills, R.C. 2000b. Leukemia and lymphoma incidence in rodents exposed to low-frequency magnetic fields. *Radiation Research*, 153(5), Part 2: 627.
- Bracken, M.B.; Belanger, K.; Hellenbrand, K.; Dlugosz, L.; Holford, T.R.; McSharry, J.E.; Adesso, K.; Leaderer, B. 1995. Exposure to electromagnetic fields during pregnancy with emphasis on electrically heated beds: association with birth weight and intrauterine growth retardation. *Epidemiology*, 6(3): 263-270.

- Burchard, J.F.; Nguyen, D.H.; Block, E. 1998. Effects of electric and magnetic fields on nocturnal melatonin concentrations in dairy cows. *J Dairy Sci.* 81(3):722-7.
- Erren, T.C. 2001. A meta-analysis of epidemiological studies of electric magnetic fields and breast cancer in women and men. *Bioelectromagnetics Supplement*, 5: S105-S119.
- Fernie, K.J.; and Bird, D.M. 1999. Effects of electromagnetic fields on body mass and food-intake of American kestrels. *The Condor.* 101:616-621.
- Fernie, K.J.; Bird, D.M.; Dawson, R.D.; Lague, P.C. 2000. Effects of electromagnetic fields on the reproductive success of American kestrels. *Physiol Biochem Zool.* 73(1):60-5.
- Gammon, M.D.; Schoenberg, J.B.; Britton, J.A.; Kelsey, J.L.; Stanford, J.L.; Malone, K.E.; Coates, R.J.; Brogan, D.J.; Potischman, N.; Swanson, C.A.; Brinton, L.A. 1998. Electric blanket use and breast cancer risk among younger women. *American Journal of Epidemiology*, 148: 556-63.
- Goodwin Jr., J.G. 1975. Big game movement near a 500-kV transmission line in northern Idaho. Bonneville Power Administration, Engineering and Construction Division, Portland, OR, June 27.
- Green, L.M.; Miller, A.B.; Villeneuve, P.J.; Agnew, D.A.; Greenberg, M.L.; Li, J.H.; Donnelly, K.E. 1999a. A case control study of childhood leukemia in southern Ontario, Canada, and exposure to magnetic fields in residences. *International Journal of Cancer*, 82:161-170.
- Green, L.M.; Miller, A.B.; Agnew, D.A.; Greenberg, M.L.; Li, J.H.; Villeneuve, P.J.; Tibshirani, R. 1999b. Childhood leukemia and personal monitoring of residential exposures to electric and magnetic fields in Ontario, Canada. *Cancer Causes and Control*, 10: 233-243.
- Greenberg, B.; Bindokas, V.P.; Frazier, M.J.; Gauger, J.R. 1981. Response of honey bees, *apis mellifera* L., to high-voltage transmission lines. *Environmental Entomology*, 10: 600-610.
- Greenland, S.; Sheppard, A.; Kelsh, M.; Kuane, W.; Poole, C.; Kelsh, M.A. 2000. Childhood leukemia and power frequency magnetic fields: analysis from pooled data of thirteen epidemiologic studies. *Epidemiology*, 11: 624-634.
- HCN (Health Council of the Netherlands). 2000. Report on Exposure to Electromagnetic Fields (0 Hz – 10 MHz). No. 2000/06E.
- Hefeneider, S.H.; McCoy, S.L.; Hausman, F.A.; Christensen, H.L.; Takahashi, D.; Perrin, N.; Bracken, T.D.; Shin, K.Y.; Hall, A.S. 2001. Long-term effects of 60-Hz electric vs. magnetic fields on IL-1 and IL-2 activity in sheep. *Bioelectromagnetics*, 22(3):170-177.
- Holmberg, B. 1995. Magnetic fields and cancer: animal and cellular evidence—an overview. *Environ Health Perspect.* 103 Suppl 2:63-7.
- Huuskonen, H.; Saastamoinen, V.; Komulainen, H.; Laitinen, J.; Juutilainen, J. 2001. Effects of low-frequency magnetic fields on implantation in rats. *Reprod Toxicol*, 15(1):49-59.
- IEE (Institution of Electrical Engineers), Biological Effects Working Party. May 2000. The possible harmful biological effects of low level electromagnetic fields of frequencies up to 300 GHz. IEE Position Statement.

- Kirschvink, J.L.; and Gould, J.L. 1981. Biogenic magnetite as a basis for magnetic field detection in animals. *Biosystems*, 13(3):181-201.
- Kirschvink, J.L.; Diaz Ricci, J.; Nesson, M.H.; Kirschvink, S.J. 1992. Magnetite-based magnetoreceptors in animals: structural, behavioral, and biophysical studies. Electric Power Research Institute (EPRI), Report No. TR-102008, Palo Alto, CA. September.
- Kroeker, G.; Parkinson, D.; Vriend, J.; Peeling, J. 1996. Neurochemical effects of static magnetic field exposure. *Surg Neurol*, 45(1):62-6.
- Laden, F.; Neas, L.M.; Tolbert, P.E.; Holmes, M.D.; Hankinson, S.E.; Spiegelman, D.; Speizer, F.E.; Hunter, D.J. 2000. Electric blanket use and breast cancer in the nurses' health study. *American Journal of Epidemiology*, 152(1): 41-49.
- Langholz, B. 2001. Factors that explain the power line configuration wiring code - childhood leukemia association: what would they look like? *Bioelectromagnetics Supplements*, 5: S19-S31.
- Larkin, R.P., and Sutherland, P.J. 1977. Migrating birds respond to Project Seafarer's electromagnetic field. *Science*, 195(4280): 777-9 1977, Feb 25.
- Lee, G.M.; Neutra, R.R.; Hristova, L.; Yost, M.; Hiatt, R.A. 2000. The use of electric bed heaters and the risk of clinically recognized spontaneous abortion. *Epidemiology*, 11: 406-415.
- Lee, J., Stormshak, F., Thompson, J., Thinesen, P., Painter, L., Olenchek, B., Hess, D., Forbes, R. 1993. Melatonin secretion and puberty in female lambs exposed to environmental electric and magnetic fields. *Biol Reprod* 49(4):857-64
- Lee, J.M. BPA Biological Studies Task Team. 1996. Electrical and biological effects of transmission lines: a review. Bonneville Power Administration, Portland, Oregon, December.
- Lee, J.M., Stormshak, F., Thompson, J., Hess, D.L., Foster, D.L. 1995. Melatonin and puberty in female lambs exposed to EMF: a replicate study. *Bioelectromagnetics*, 16(2):119-23
- Linnet, M.S.; Hatch E.H.; Kleinerman, R.A.; Robinson, L.L.; Kaune, W.T.; Friedman, D.R.; Seversch, R.K.; Haines, C.M.; Hartsock, C.T.; Niwa, S.; Wacholder, S.; Tarone, R.E. 1997. Residential exposure to magnetic fields and acute lymphoblastic leukemia in children. *New England Journal of Medicine*, 337: 1-7.
- Loberg, L.I.; Engdahl, W.R.; Gauger, J.R.; McCormick, D.L. 2000. Expression of cancer-related genes in human cells exposed to 60 Hz magnetic fields. *Radiation Research*, 153(5): 679-684.
- McBride, M.L.; and Gallagher, RP; Theriault, G; Armstrong, BG; Tamaro, S; Spinelli, JJ; Deadman, JE; Fincham, S; Robinson, D; Choi, W. 1999. Power-frequency electric and magnetic fields and risk of childhood leukemia in Canada. *American Journal of Epidemiology*, 149:831-842.
- McCormick, D.L.; Boorman, G.A.; Findlay, J.C.; Hailey, J.R.; Johnson, T.R.; Gauger, J.R.; Pletcher, J.M.; Sill, R.C.; Haseman, J.K. 1999. Chronic toxicity/oncogenicity evaluation of 60 Hz (power frequency) magnetic fields in B6C3F mice. *Toxicologic Pathology*, 27:279-285.



- Neutra, R.R., and Del Pizzo, V. 2001. A richer conceptualization of "exposure" for epidemiological studies of the "EMF mixture". *Bioelectromagnetics Supplements*, 5: S48-S57.
- NIEHS (National Institute of Environmental Health Sciences). 1998. Assessment of Health Effects from Exposure to Power-Line Frequency Electric and Magnetic Fields: Working Group Report. NIH Publication No. 98-3981. Research Triangle Park, NC: National Institute of Environmental Health Sciences of the U.S. National Institutes of Health.
- NIEHS (National Institute of Environmental Health). 1999. Health effects from exposure to power line frequency electric and magnetic fields. NIH; National Institute of Health; NIH No. 99-4493; Research Triangle Park, NC.
- NRC (National Research Council). 1997. An evaluation of the U.S. Navy's extremely low frequency communications system ecological monitoring program. National Academy Press, Washington, D.C.
- NRPB (National Radiological Protection Board). 2001. Response statement of the NRPB: ELF electromagnetic fields and the risk of cancer. National Radiological Protection Board, Chilton, Didcot, Oxon, Volume 12, No.1, ISBN 0-859951-456-0.
- Picton, H.D., Canfield, J.E., Nelson, G.P. 1985. The impact of a 500-kV transmission line upon the North Boulder Winter Elk Range. US Forest Service Contract 53-0398-30E-3.
- Raaschou-Nielsen, O.; Hertel, O.; Thomsen, B.L.; Olsen, J.H. 2001. Air pollution from traffic at the residence of children with cancer. *American Journal of Epidemiology*, 153(5): 433-43.
- Radiation Research*. 2000. (Special Edition Updating RAPID results.) 153(5): 637-641. *See entries under Balcer-Kubiczek, Boorman, Loberg, and Ryan.*
- Reynolds, P.; Elkin, E.; Scalf, R.; Von Behren, J.; Neutra, R.R. 2001. A case-control pilot study of traffic exposures and early childhood leukemia using a geographic information system. *Bioelectromagnetics Supplements*, 5:S58-S6.
- Rogers, L.E., Beedlow, P.A., Carlile, D.W., Ganok, K.A., Lee, J.M. 1984. Environmental studies of a 1100-kV prototype transmission line: an annual report for the 1984 study period. Prepared by Battelle Pacific Northwest Laboratories for Bonneville Power Administration, Portland, Oregon.
- Ryan, B.M.; Symanski, R.R.; Pomeranz, L.E.; Johnson, T.R.; Gauger, J.R.; McCormick, D.L. 1999. Multi-generation reproduction toxicity assessment of 60-Hz magnetic fields using a continuous breeding protocol in rats. *Teratology*, 59(3): 156-62.
- Ryan, B.M.; Polen, M.; Gauger, J.R.; Mallett, E.; Kerns, M.B.; Bryan, T.L.; McCormick, D.L. 2000. Evaluation of the developmental toxicity in Sprague-Dawley rats. *Radiation Research*, 153(5): 637-641.
- Savitz, D.A., Wachtel, H., Barnes, F.A., John, E.M. & Tvrdik, J.G. 1988. Case-control study of childhood cancer and exposure to 60 Hz magnetic fields. *American Journal of Epidemiology*, 128, 21-38.
- Schuz, J.; Grigat, J.P.; Brinkmann, K.; Michaelis, J. 2001. Residential magnetic fields as a risk factor for childhood acute leukaemia: results from a German population-based case-control study. *International Journal of Cancer*, 91(5): 728-735. January 2.

- Southern, W.E. 1975. Orientation of gull chicks exposed to project Sanguine's electromagnetic field. *Science*, 189: 143-144.
- Stormshak, F., Bracken, T.D., Carey, M., Chartier, V., Dickson, L., Forbes, R., Hall, A., Havens, P., Hess, D., Krippaehne, S., Lee, J., Ogden, B., Olenchek, B., Painter, L., Rowe, K., Stearns, R., Thinesen, P., Thompson, J. 1992. Joint HVAC transmission EMF environmental study: final report on experiment 1. Bonneville Power Administration, Contract # DE-B179-90BPO4293, Portland, OR, May.
- Thompson, J.M.; Stormshak, F.; Lee, J.M.; Hess, D.; Painter, L. 1995. Cortisol secretion and growth in ewe lambs chronically exposed to electric and magnetic fields of a 60-Hertz 500-kilovolt AC transmission line. *J Animal Sci*, 73(11):3274-80
- UKCCS (United Kingdom Childhood Cancer Study Investigators). 1999. Exposure to power frequency magnetic fields and the risk of childhood cancer. *The Lancet*, 353(9194): 1925-31.
- UKCCS (United Kingdom Childhood Cancer Study Investigators). 2000. Childhood cancer and residential proximity to power lines. *British Journal of Cancer*, 83:1573-80.
- Vollrath, L.; Spessert, R.; Kratzsch, T.; Keiner, M.; Hollmann H. 1997. No short-term effects of high-frequency electromagnetic fields on the mammalian pineal gland. *Bioelectromagnetics*, 18(5):376-87.
- Walcott, C.; Gould, J.L.; Lednor, A.J. 1988. Homing of magnetized and demagnetized pigeons. *J Exp Biol*, 134:27-41.
- Walker, C.E.; Seitelman, D.L.; McElhaney, J.H.; Mullen, S.P.; Hagadorn, B.; Seto, Y.J. 1982. Effects of high-intensity 60-Hz fields on bone growth. *Journal of Bioelectricity*, 1(3):339-349.
- Wartenberg, D. 2001a. The potential impact of bias in studies of residential exposure to magnetic fields and childhood leukemia. *Bioelectromagnetics Supplements*, 5: S32-S47.
- Wartenberg, D. 2001b. Residential EMF exposure and childhood leukemia: Meta-analysis and population attributable risk. *Bioelectromagnetics Supplements*, 5: S86-S104.
- Wilson, B.W.; Anderson, L.E.; Hilton, D.I.; Phillips, RD. 1981. Chronic exposure to 60-Hz electric fields: effects on pineal function in the rat. *Bioelectromagnetics*, 2(4):371-80.
- Wrensch, M.; Yost, M.; Miike, R.; Lee, G.; Touchstone, J. 1999. Adult glioma in relation to residential power frequency electromagnetic field exposures in the San Francisco Bay Area. *Epidemiology*, 10: 523-527.
- Zaffanella, L.E. 1993. Survey of residential magnetic field sources. Vol. 1: Goals, results, and conclusions. (EPRI TR-102759-V1, Project 3335-02). Electric Power Research Institute, Palo Alto, CA.
- Zheng, T.Z.; Holford, T.R.; Mayne, S.T.; Owens, P.H.; Zhang, B.; Boyle, P.; Carter, D.; Ward, Y.W.; Zahm, S.H. 2000. Exposure to electromagnetic fields from use of electric blankets and other in-home electrical appliances and breast cancer risk. *American Journal of Epidemiology*, 151(11): 1103-11.

## LIST OF PREPARERS

**Linda S. Erdreich, Ph.D.**, is a Managing Scientist in the Health Group at Exponent. She received her Ph.D. in Epidemiology and an M.S. in Biostatistics and Epidemiology from The University of Oklahoma Health Sciences Center. Dr. Erdreich is an epidemiologist with specific expertise in biological and health research related to non-ionizing radiation, both radiofrequency and power-frequency fields. Formerly, she was Acting Section Chief and Group Leader of the Methods Evaluation and Development Staff at the U.S. Environmental Protection Agency (EPA) and Senior Epidemiologist of the Environmental Criteria and Assessment Office at the EPA. While at the EPA, she developed methods in quantitative health risk assessment, coordinated the drafting of federal guidelines, and participated in science policy decisions. Both in government and private industry, she has provided rigorous evaluations of the impact on public health or occupational health of a variety of chemicals, therapeutic drugs, and physical agents, including electric and magnetic fields. As a member of the Institute of Electrical and Electronics Engineers (IEEE) Standards Coordinating Committees on Non-Ionizing Radiation, Dr. Erdreich is chairman of a working group to evaluate epidemiologic data on radiofrequency exposures (3 kHz–300 GHz). She has been appointed as a member of the Committee on Man and Radiation (COMAR) of the IEEE's *Engineering in Biology and Medicine Society*. Dr. Erdreich serves as Adjunct Associate Professor at the University of Medicine & Dentistry of New Jersey.

**William H. Bailey, Ph.D.**, is a Principal Scientist and manages the Health Group scientists in Exponent's New York office. Before joining Exponent, Dr. Bailey was President of Bailey Research Associates, Inc., the oldest research and consulting firm with specialized expertise in electro-magnetic fields and health. Dr. Bailey specializes in applying state-of-the-art assessment methods to environmental health and impact issues. His 30 years of training and experience include laboratory and epidemiologic research, health risk assessment, and comprehensive exposure analysis. Dr. Bailey is particularly well known for his research on potential health effects of electromagnetic fields and is active in setting IEEE standards for human exposure to electromagnetic fields. He uses advanced analytical and statistical methods in the design and analysis of both experimental studies and epidemiology and survey research studies. In addition, Dr. Bailey's postgraduate training in the social, economic, and behavioral sciences is helpful in assessing the important effects of social, economic, and community factors on health risks and vulnerability to environmental impacts in health and environmental justice research. He is a member of a working group that advises a committee of the World Health Organization on risk assessment, perception, and communication. Dr. Bailey is also a visiting scientist at the Cornell University Medical College. He was formerly Head of the Laboratory of Neuropharmacology and Environmental Toxicology at the New York State Institute for Basic Research, Staten Island, New York, and an Assistant Professor and NIH postdoctoral fellow in Neurochemistry at The Rockefeller University in New York.

**Maria DeJoseph, M.S.**, is an Epidemiologist in Exponent's Health Group and is based in New York, New York. Ms. DeJoseph has a background in epidemiology and biological sciences. She served as the primary investigator for a case-control epidemiologic study of her design to investigate a mediastinitis outbreak in cardiothoracic surgery patients. Ms. De Joseph also has recruited and interviewed subjects, and analyzed hormone levels for an epidemiologic breast cancer study. She has conducted phytochemical analyses of medicinal plants, including the isolation and fractionation of tropical plants used medicinally by indigenous peoples and primates of Central and South America. Ms. DeJoseph has served as an ethnobotanical and zoopharmacological field researcher in Mexico, Costa Rica and Venezuela. She has used a variety of methods to identify chemical and prospective pharmaceutical compounds, including HPLC, column chromatography, anti-microbial assays, gas chromatography mass spectrometry (GC-MS), and nuclear magnetic resonance spectroscopy (NMR). Before joining exponent, Ms. DeJoseph was a Research Assistant in the Medical School, Division of Epidemiology at Stanford University.

*This page intentionally left blank.*

## 5.0 Persons and Agencies Consulted

### 5.1 Federal Agencies

- United States Fish and Wildlife Service
- National Marine Fisheries Service
- United States Army Corps of Engineers

### 5.2 State Agencies

- Oregon State Office of Archaeology and Historic Preservation
- Oregon Department of Fish and Wildlife
- Oregon Department of Environmental Quality
- Oregon Division of State Lands
- Oregon Department of Land Conservation and State Lands
- Energy Facility Siting Council, Oregon Department of Energy
- Oregon Department of Transportation

### 5.3 Local Agencies

- Linn County Planning and Building Department
- Marion County Planning and Building Department
- Marion County Department of Community Development

### 5.4 Tribes

- Confederated Tribes of Grand Ronde

### 5.5 Utilities

- Portland General Electric

### 5.6 Landowners

There are approximately 100 landowners on the mailing list.



## 6.0 References

- Applied Archaeological Research. May 22, 2001. Results of a Cultural Resources Survey of the Bonneville Power Administration's Santiam-Bethel Tap Transmission Line Project, Marion County, Oregon. (Applied Archaeological Research Report No. 181) Portland, OR. Prepared for Bonneville Power Administration, Portland, OR.
- Bonneville Power Administration. 2000. Transmission system vegetation management program. Final environmental impact statement. DOE/EIS-0285. Portland, OR.
- Bracken, T. Dan. June 2001. Santiam-Bethel Transmission Project, *Appendix A, Electrical Effects*.
- Cowardin, L. M., V. Carter, F. C. Golet, and E. T. LaRoe. 1979. Classification of wetlands and deep water habitats of the United States. (FWS/OBS-79/31.) U.S. Fish and Wildlife Service. Washington, DC.
- Fennimore, Joe. June 8, 2001. Associate Planner, Marion County Community Development Department. Telephone conversation..
- Hopkins, S. Planner. May 1, 2001. Linn County Planning Department, OR. Telephone conversation.
- Hunt, W. April 30, 2001. Assistant district fish biologist. Oregon Department of Fish and Wildlife, Corvallis, OR. Telephone conversation.
- Jones & Stokes. May 17, 2001. Upgrade to the Bonneville Power Administration Santiam to Bethel, Oregon transmission line. Draft biological assessment. (J&S 0P008.01.) Bellevue, WA. Prepared for Bonneville Power Administration, Portland, OR.
- Linn County, Oregon. 2000. Linn County parks. Available: <<http://www.co.linn.or.us/>>. Accessed May 8, 2001.
- \_\_\_\_\_. 2001. Recreational facilities. Available: <<http://www.co.linn.or.us/>>. Accessed April 20, 2001.
- Marion County, Oregon. 2001. Recreational facilities. Available: <<http://www.co.marion.or.us>>. Accessed April 20, 2001.
- Maser, C. 1998. Mammals of the Pacific Northwest: from the coast to the high Cascades. Oregon State University Press. Corvallis, OR.
- McMaster, K. State Supervisor, USFWS Oregon State Office, Portland, OR. October 27, 2000 – letter to Leslie Kelleher of Bonneville Power Authority.
- Mitsch, W.J., and J.G. Gosselink. 1993. Wetlands. International Thomson Publishing. New York, NY.
- ODFW (Oregon Department of Fish and Wildlife). 1993. Oregon wildlife diversity plan. Portland, OR.

- ODFW. 1997. Oregon Department of Fish and Wildlife guidelines and criteria for stream-road crossings. Portland, OR.
- Oregon Department of Environmental Quality. 1998a. Map of 303(d) listed waterbodies and sub basin priorities. Available: <<http://waterquality.deq.state.or.us/WQLData/303dListMap.htm>>. Accessed April 26, 2001.
- Oregon Department of Environmental Quality. 1998b. Final 1998 303(d) file download page. Available: <<http://waterquality.deq.state.or.us/wq/303dlist/Download303d.htm>>. Accessed. April 26, 2001.
- Oregon Labor Market Information System. 2001. Oregon Employment Department unemployment and poverty statistics. Available: <<http://www.olmis.org>>. Accessed April 16, 2001.
- Oregon Natural Heritage Program. 2001. Natural Heritage database. Portland, OR.
- Oregon State University. 1997a. Oregon agriculture census, Linn County, 1997. Available: <<http://govinfo.library.orst.edu/cgi-bin/ag-list?01-043.orc>>. Accessed May 10, 2001.
- \_\_\_\_\_. 1997b. Oregon agriculture census, Linn County, 1997. Available: <<http://govinfo.library.orst.edu/cgi-bin/ag-list?28-043.orc>>. Accessed May 10, 2001.
- \_\_\_\_\_. 1997c. Oregon agriculture census, Marion County, 1997. Available: <<http://govinfo.library.orst.edu/cgi-bin/ag-list?01-047.orc>>. Accessed May 10, 2001.
- \_\_\_\_\_. 1997d. Oregon agriculture census, Marion County, 1997. Available: <<http://govinfo.library.orst.edu/cgi-bin/ag-list?28-047.orc>>. Accessed May 10, 2001.
- Oregon State University, Agricultural Extension. 1999. Oregon State University Extension agricultural statistics, Linn County, last updated April 23, 2001. Available: <<http://oregonstate.edu/extension/linn/Agstats1.html>>. Accessed May 10, 2001.
- Oregon State University, Extension Economic Information Office. 1999. Marion County agricultural commodity sales, 1999 (preliminary), last updated April 18, 2000. Available: <<http://www.open.org/~mcboc/agsales.htm>>. Accessed May 10, 2001.
- Portland State University Population Research Center. 2000. Population, ethnic, gender, and age distribution. Available: <<http://www.upa.pdx.edu/CPRC/>>. Accessed April 11, 2001.
- Salem OnLine. 2000. Salem OnLine. Available: <<http://www.salemlodging.com/index.html>>. Accessed May 8, 2001.
- U.S. Bureau of the Census. 1997. 1997 Model-based income and unemployment estimates. Available: <<http://www.census.gov>>. Accessed April 10, 2001.
- \_\_\_\_\_. 2000. 1999 unemployment rates. Available: <<http://www.census.gov>>. Accessed April 10, 2001.
- U.S. Bureau of Economic Analysis. 1998. Regional accounts data, employment sectors, annual earnings by industry sector, income and unemployment. Available: <<http://www.bea.doc.gov/bea/regional/reis/ca05>>. Accessed April 18, 2001.



USFWS (U.S. Fish and Wildlife Service). 1986. Recovery plan for the Pacific bald eagle. USDI Fish and Wildlife Service, Portland, OR.

USGS. 2000a. Groundwater atlas of the United States: Idaho, Oregon, and Washington. HA730-H. Available: <[http://capp.water.usgs.gov/gwa/ch\\_h/jpeg/H083.jpeg](http://capp.water.usgs.gov/gwa/ch_h/jpeg/H083.jpeg)>. Accessed April 30, 2001.

\_\_\_\_\_. 2000b. 1990 water use. Available: <<http://water.usgs.gov>>. Accessed April 30, 2001.

Wheeldon, Robert. June 6, 2001. Associate Planner, Linn County Planning and Building Department. Telephone conversation.



## 7.0 Glossary and Acronyms

### Acronyms

A	Ampere
BPA	Bonneville Power Administration
CWA	Clean Water Act
DLC	Donation Land Claim
EFH	Essential Fish Habitat
EMF	Electric and magnetic fields
EMI	Electromagnetic Interference
EPA	Environmental Protection Agency
ESU	Evolutionarily Significant Unit
FAA	Federal Aviation Administration
FCC	Federal Communication Commission
FEMA	Federal Emergency Management Agency
NAS	National Academy of Sciences
NEPA	National Environmental Policy Act
NESC	National Electrical Safety Code
NIEHS	National Institute of Environmental Health Sciences
NPDES	National Pollutant Discharge Elimination System
NRC	National Research Council
NWI	National Wetland Inventory
ODFW	Oregon Department of Fish and Wildlife
PEM	Palustrine emergent
PGE	Portland General Electric
PFO	Palustrine forested
PSS	Palustrine scrub-shrub
RI	Radio Interference
ROW	Right-of-way

SWPP	Stormwater Pollution Prevention
TVI	Television Interference
USFWS	U.S. Fish and Wildlife Service
USGS	U.S. Geological Service

### **Technical Terms**

Anadromous	Refers to fish such as salmon that hatch and rear in fresh water, move to the ocean to mature, and then return to fresh water to reproduce.
Alluvium	Material such as sand, silt, or clay that has been deposited on land by running water of streams and rivers.
Arcing	The process of current flowing across a gap, such as fault current flowing across an insulator string that flashed over due to a lightening strike.
Biological Assessment	A document required by the Endangered Species Act, which requires an evaluation of potential effects on listed species and critical habitat prior to implementing a proposed action. A proposed action is defined as any activity authorized, funded or carried out by a federal agency.
Blackouts	The disconnection of the source of electricity from all the electrical loads in a certain geographical area. Brought about by an emergency forced outage or other fault in the generation, transmission or distribution system serving the area.
Capacity	A measure of the ability of the transmission line to carry electricity.
Circuit	A system of conductors through which an electric current is intended to flow.
Conductor	Any metallic material, usually in the form of wire, cable, or bar, suitable for carrying an electrical current.
Corona	The phenomenon whereby the electric field associated with a power line cause ionization (molecular breakdown) of surrounding air, thus creating a high-frequency noise. This noise can be heard as static over an automobile radio when travelling under the power line.
Danger tree	Trees that pose a danger or hazard to the transmission line.
Double-circuit line	To place two separate electrical circuits on the same transmission structures or poles. Each circuit contains three separate conductors or bundles of conductors.

Floodplain	That portion of a river valley adjacent to the stream channel which is covered with water when the stream overflows its banks during flood stage.
Lattice steel	Refers to transmission towers constructed of multiple steel members that are connected together (usually in triangular shapes) to make up a frame.
Load	The amount of electric energy delivered or required at any specific point or points on a system. Load originates primarily at the energy using equipment of consumers, such as heaters, air conditioners, lights and motors. At BPA, load includes delivery to direct service industries (Note: Load is slightly larger than metered energy because of normal transmission and distribution losses in delivery from generator to consumer). Because loads are used to determine resource requirements, forecasts of electricity use are converted to loads.
Median	The middle number in a given sequence of numbers.
Mitigation	Steps taken to remove or lessen the effects predicted for each resource, as potentially caused by the transmission project. They may include reducing the impact, compensating for the impact, or avoiding it entirely. Some measures, such as adjusting the location of the towers to avoid a particular resource, are taken during the study and location process. Others, such as reseeding access roads, and/or avoiding the proliferation of weeds, are taken following project completion.
National Electrical Safety Code (NESC)	Written standards for the design, construction, maintenance and operation of electric supply and communication lines, equipment, and supply station in order to safeguard persons from hazards associated with those activities.
National Environmental Policy Act (NEPA)	A 1969 federal law that required evaluation of the environmental impact of federally funded projects and programs.
Noxious weeds	Plants that are injurious to public health, crops, livestock, land, or other property.
Outage	An event, caused by a disturbance on the electrical system, that requires BPA to remove a piece of equipment or a section of line from service. The disturbance can be either natural or caused by humans.
Overload	When too much current flows through transmission facilities that could cause damage or overheating. In the event of overloading, equipment has safeguards to disconnect it from the flow of electricity.

Palustrine emergent wetland	A shallow freshwater wetland characterized by erect, rotted, herbaceous hydrophytes (water loving plants).
Palustrine forested wetland	A wetland characterized by woody vegetation that is 20 feet or more in height.
Palustrine scrub-shrub wetland	A wetland dominated by woody vegetation less than 20 feet tall. This vegetation includes true shrubs, young trees, and trees and shrubs that are small or stunted because of environmental conditions.
Peak load	The maximum electrical load or the maximum average load during a designated interval such as 15 minutes.
Per capita	Per person
Reliability	The measure of the ability of a power system to provide uninterrupted service, even while that system is under stress.
Right-of-way (ROW)	An easement for a certain purpose over the land of another, such as a strip of land, electric transmission line ditch or pipeline. BPA usually acquires easements for its transmission lines, roads and other facilities such as guys and anchors.
Single-circuit	One electrical circuit consisting of three separate conductors or three bundles of conductors.
Substation	A non-generating electrical power station that serves to transform voltages to higher or lower levels, and that serves as a delivery point to individual customers such as utilities or large industrial plants. The BPA system has more than 400 substations.
Tap	A short transmission line that connects a substation to an existing transmission line.
Transmission grid	An interconnected network of transmission lines and associated equipment for the bulk transfer of electric energy between points of supply and demand. The BPA transmission grid includes some 22,500 circuit kilometers (14,00 circuit miles) of lines connecting more than 400 substations in the Pacific Northwest. The main grid consists of 230-kV, 345-kV, and 500-kV transmission lines.
Transmission line	A high-voltage power line used to carry electric power efficiently over long distances.
Voltage	The driving force that cause a current to flow in an electric circuit. Voltage and volt are often used interchangeably.
Wetlands	An area where the soil experiences anaerobic conditions because of inundation of water during part of any given year. Indicators of a wetland include types of plants, soil characteristics and hydrology.



**SANTIAM - BETHEL TRANSMISSION PROJECT**

**APPENDIX A**  
**ELECTRICAL EFFECTS**

June 2001

Prepared by  
**T. Dan Bracken, Inc.**

for  
**Bonneville Power Administration**





## Table of Contents

<b>1.0</b>	<b>Introduction</b> .....	<b>1</b>
<b>2.0</b>	<b>Physical Description</b> .....	<b>3</b>
2.1	Proposed Line.....	3
2.2	Existing Lines.....	3
<b>3.0</b>	<b>Electric Field</b> .....	<b>3</b>
3.1	Basic Concepts.....	3
3.2	Transmission-line Electric Fields.....	4
3.3	Calculated Values of Electric Fields.....	5
3.4	Environmental Electric Fields.....	6
<b>4.0</b>	<b>Magnetic Field</b> .....	<b>7</b>
4.1	Basic Concepts.....	7
4.2	Transmission-line Magnetic Fields.....	8
4.3	Calculated Values for Magnetic Fields.....	9
4.4	Environmental Magnetic Fields.....	9
<b>5.0</b>	<b>Electric and Magnetic Field (EMF) Effects</b> .....	<b>12</b>
5.1	Electric Fields: Short-term Effects.....	12
5.2	Magnetic Field: Short-term Effects.....	15
<b>6.0</b>	<b>Regulations</b> .....	<b>16</b>
<b>7.0</b>	<b>Audible Noise</b> .....	<b>17</b>
7.1	Basic Concepts.....	17
7.2	Transmission-line Audible Noise.....	19
7.3	Predicted Audible Noise Levels.....	19
7.4	Discussion.....	20
7.5	Conclusion.....	20
<b>8.0</b>	<b>Electromagnetic Interference</b> .....	<b>20</b>
8.1	Basic Concepts.....	20
8.2	Radio Interference (RI).....	21
8.3	Predicted RI Levels.....	21
8.4	Television Interference (TVI).....	22
8.5	Predicted TVI Levels.....	22
8.6	Interference with Other Devices.....	22
8.7	Conclusion.....	22
<b>9.0</b>	<b>Other Corona Effects</b> .....	<b>23</b>
<b>10.0</b>	<b>Summary</b> .....	<b>23</b>
	<b>List of References Cited</b> .....	<b>25</b>
	<b>List of Preparers</b> .....	<b>29</b>

## List of Tables

Table 1:	Physical and electrical characteristics of Santiam - Bethel Project corridors.....	31
Table 2:	Possible corridors for Santiam - Bethel Project .....	31
Table 3:	Calculated electric fields for configurations of the proposed Santiam - Bethel/ Santiam-Chemawa 230-kV line operated at maximum voltage .....	32
Table 4	Calculated magnetic fields for configurations of the proposed Santiam – Bethel/ Santiam - Chemawa 230-kV line operated at maximum current .....	33
Table 5	States with transmission-line field limits .....	34
Table 6	Common noise levels .....	35
Table 7	Typical sound attenuation (in decibels) provided by buildings .....	35
Table 8	Predicted foul-weather audible noise (AN) levels at edge of right-of-way (ROW) for proposed Santiam – Bethel/Santiam - Chemawa 230-kV line .....	36
Table 9	Predicted fair-weather radio interference (RI) levels at 100 feet (30.5 m) from the outside conductor of the proposed Santiam – Bethel/Santiam - Chemawa 230-kV line.....	36
Table 10	Predicted maximum foul-weather television interference (TVI) levels predicted at 100 feet (30.5 m) from the outside conductor of the proposed Santiam – Bethel/Santiam - Chemawa 230-kV line.....	37

## List of Figures

Figure 1	Configurations for proposed Santiam – Bethel/ Santiam- Chemawa 230-kV line: a) proposed line with no parallel lines (Configuration I); and b) proposed line with parallel 500-kV line (Configuration II).....	38
Figure 2	Electric-field profiles for configurations of proposed Santiam – Bethel/Santiam - Chemawa 230-kV line: a) proposed line with no parallel line (Configuration I); and b) proposed line with parallel 500-kV line (Configuration II) .....	39
Figure 3	Magnetic-field profiles for selected configurations of the proposed Santiam - Bethel/ Santiam – Chemawa 230-kV line for maximum current conditions: a) proposed line with no parallel line (Configuration I); and b) proposed line with parallel 500-kV line (Configuration II).....	40

# ELECTRICAL EFFECTS FROM THE PROPOSED SANTIAM - BETHEL TRANSMISSION PROJECT

## 1.0 Introduction

The Bonneville Power Administration (BPA) is proposing to build a 16.7-mile (mi.) (26.9-kilometer [km]) 230-kilovolt (kV) transmission line from the Santiam Substation near Stayton, Oregon, to a tap point on the existing PGE 230-kV Bethel line near Salem, Oregon. The proposed Santiam - Bethel Transmission Project would replace 16.7 mi. (26.9 km) of the single-circuit Santiam - Chemawa 230-kV line with a double-circuit 230-kV line. The proposed double-circuit line would consist of the new Santiam - Bethel 230-kV line and the rebuilt Santiam - Chemawa 230-kV line. Configurations along the existing line route include the right-of-way with no parallel lines (15.2 mi. or 24.5 km) and the right-of-way parallel to an existing 500-kV line (1.5 mi. or 2.4 km). The purpose of this report is to describe and quantify the electrical effects of the proposed Santiam - Bethel Transmission Project. These include the following:

- the levels of 60-hertz (Hz; cycles per second) electric and magnetic fields (EMF) at 3.28 feet (ft.) or 1 meter (m) above the ground,
- the effects associated with those fields,
- the levels of audible noise produced by the line, and
- electromagnetic interference associated with the line.

Electrical effects occur near all transmission lines, including those already present along the proposed route for the Santiam - Bethel line. Therefore, the levels of these quantities for the proposed line are computed and compared with those from the existing lines along the route.

The voltage on the conductors of transmission lines generates an electric field in the space between the conductors and the ground. The electric field is calculated or measured in units of volts-per-meter (V/m) or kilovolts-per-meter (kV/m) at a height of 3.28 ft. (1 m) above the ground. The current flowing in the conductors of the transmission line generates a magnetic field in the air and earth near the transmission line; current is expressed in units of amperes (A). The magnetic field is expressed in milligauss (mG), and is usually measured or calculated at a height of 3.28 ft. (1 m) above the ground. The electric field at the surface of the conductors causes the phenomenon of corona. Corona is the electrical breakdown or ionization of air in very strong electric fields, and is the source of audible noise, electromagnetic radiation, and visible light.

To quantify EMF levels along the route, the electric and magnetic fields from the proposed and existing lines were calculated using the BPA Corona and Field Effects Program (USDOE, undated). In this program, the calculation of 60-Hz fields uses standard superposition techniques for vector fields from several line sources: in this case, the line sources are transmission-line conductors. (Vector fields have both magnitude and direction: these must be taken into account when combining fields from different sources.) Important input parameters to the computer program are voltage, current, and geometric configuration of the line. The transmission-line conductors are assumed to be straight, parallel to each other, and located above and parallel to an infinite flat ground plane. Although such conditions do not

occur under real lines because of conductor sag and variable terrain, the validity and limitations of calculations using these assumptions have been well verified by comparisons with measurements. This approach was used to estimate fields for the proposed Santiam - Bethel line, where minimum clearances were assumed to provide worst-case (highest) estimates for the fields.

Electric fields are calculated using an imaging method. Fields from the conductors and their images in the ground plane are superimposed with the proper magnitude and phase to produce the total field at a selected location.

The total magnetic field is calculated from the vector summation of the fields from currents in all the transmission-line conductors. Balanced currents are assumed for each three-phase circuit; the contribution of induced image currents in the conductive earth is not included. Peak currents and power flow direction for the proposed and existing lines were provided by BPA and are based on the projected winter peak power loads in 2006. In the case of corridors with more than one line, calculations were performed for similar (maximum) current conditions on both lines.

Electric and magnetic fields for the proposed line were calculated at the standard height (3.28 ft. or 1 m) above the ground (IEEE, 1987). Calculations were performed out to 300 ft. (91 m) from the centerline of the existing corridor. The validity and limitations of such calculations have been well verified by measurements. Because maximum voltage, maximum current, and minimum conductor height above-ground are used, ***the calculated values given here represent worst-case conditions:*** i.e., the calculated fields are higher than they would be in practice. Such worst-case conditions would seldom occur.

The corona performance of the proposed line was also predicted using the BPA Corona and Field Effects Program (USDOE, undated). Corona performance is calculated using empirical equations that have been developed over several years from the results of measurements on numerous high-voltage lines (Chartier and Stearns, 1981; Chartier, 1983). The validity of this approach for corona-generated audible noise has been demonstrated through comparisons with measurements on other lines all over the United States (IEEE Committee Report, 1982). The accuracy of this method for predicting corona-generated radio and television interference from transmission lines has also been established (Olsen et al., 1992). Important input parameters to the computer program are voltage, current, conductor size, and geometric configuration of the line.

Corona is a highly variable phenomenon that depends on conditions along a length of line. Predictions of the levels of corona effects are reported in statistical terms to account for this variability. Calculations of audible noise and electromagnetic interference levels were made under conditions of an estimated average operating voltage (235 kV for the proposed line) and with the average line height (43 ft. or 13.1 m). Levels of audible noise, radio interference, and television interference are predicted for both fair and foul weather; however, corona is basically a foul-weather phenomenon. Wet conductors can occur during periods of rain, fog, snow, or icing. Along the route of the proposed Santiam - Bethel transmission line, such conditions are expected to occur about 22% of the time during a year, based on hourly records for the Salem airport from 1996 to 1999. Corona activity also increases with altitude. For purposes of evaluating corona effects from the proposed line, an altitude of 500 ft. (152 m) was assumed.

## **2.0 Physical Description**

### **2.1 Proposed Line**

The proposed double-circuit line would consist of two three-phase circuits, the new Santiam - Bethel 230-kV line and the rebuilt Santiam - Chemawa 230-kV line. Both circuits would have maximum phase-to-phase voltages of 242 kV. The average voltage of the lines would be 235 kV. The maximum electrical current on the lines would be 755 and 644 amperes per phase for the Santiam - Bethel and Santiam - Chemawa lines, respectively. The estimated currents are based on the BPA projected normal winter peak load in 2006. The load factor for these loads is 0.60 (average load = peak load x load factor). BPA provided the physical and operating characteristics of the proposed and existing lines.

The physical dimensions and electrical characteristics for the configuration of the proposed line are shown in Figure 1, and summarized in Table 1. Each phase of the proposed and rebuilt 230-kV lines will have a single 1.600-inch (in.) (4.1 centimeter [cm]) diameter steel-reinforced aluminum conductor (ACSR). Voltage and current waves are displaced by 120° in time (one-third of a cycle) on each electrical phase. The horizontal phase spacing between the upper and lower conductor positions of the two circuits would be 24.5 ft. (7.5 m); the horizontal spacing between the middle conductor positions would be 40.5 ft. (12.3 m). The vertical spacing between the conductor positions would be 18 ft. (5.5 m). Minimum conductor-to-ground clearance would be 31 ft. (9.5 m) at a conductor temperature of 122°F (50°C), which represents maximum operating conditions and high ambient air temperatures; clearances above ground would be greater under normal operating temperatures. The average clearance above ground along a span will be approximately 43 ft. (13.1 m); this value was used for corona calculations. At road crossings, the ground clearance would be at least 39 ft. (11.9 m). The 31-ft. (9.5-m) minimum clearance provided by BPA is greater than the minimum distance of the conductors above ground required to meet the National Electric Safety Code (NESC) (IEEE, 1990). The final design of the proposed line could entail larger clearances. The right-of-way width for the proposed line is 125 ft. (38 m).

### **2.2 Existing Lines**

The proposed double-circuit 230-kV line would replace a section of the existing Santiam - Chemawa 230-kV line along the entire route. There are two possible configurations along the existing Santiam - Chemawa line route: either no parallel line or parallel to the existing BPA Marion - Santiam No. 1 and No. 2 double-circuit 500-kV line (Table 2).

BPA provided information on currents for the existing Santiam - Chemawa line and for the Marion - Santiam No.1 500-kV line. The Marion - Santiam No. 2 line is not energized. The physical and electrical characteristics of the corridor configurations that were analyzed are given in Table 1; cross-sections of the corridors are shown in Figure 1.

## **3.0 Electric Field**

### **3.1 Basic Concepts**

An electric field is said to exist in a region of space if an electrical charge, at rest in that space, experiences a force of electrical origin (i.e., electric fields cause free charges to move). Electric field is a vector quantity: that is, it has both magnitude and direction. The direction corresponds to the direction

that a positive charge would move in the field. Sources of electric fields are unbalanced electrical charges (positive or negative) and time-varying magnetic fields. Transmission lines, distribution lines, house wiring, and appliances generate electric fields in their vicinity because of unbalanced electrical charge on energized conductors. The unbalanced charge is associated with the voltage on the energized system. On the power system in North America, the voltage and charge on the energized conductors are cyclic (plus to minus to plus) at a rate of 60 times per second. This changing voltage results in electric fields near sources that are also time-varying at a frequency of 60 hertz (Hz; a frequency unit equivalent to cycles per second).

As noted earlier, electric fields are expressed in units of volts per meter (V/m) or kilovolts (thousands of volts) per meter (kV/m). Electric- and magnetic-field magnitudes in this report are expressed in root-mean-square (rms) units. For sinusoidal waves, the rms amplitude is given as the peak amplitude divided by the square root of two.

The spatial uniformity of an electric field depends on the source of the field and the distance from that source. On the ground, under a transmission line, the electric field is nearly constant in magnitude and direction over distances of several feet (1 meter). However, close to transmission- or distribution-line conductors, the field decreases rapidly with distance from the conductors. Similarly, near small sources such as appliances, the field is not uniform and falls off even more rapidly with distance from the device. If an energized conductor (source) is inside a grounded conducting enclosure, then the electric field outside the enclosure is zero, and the source is said to be shielded.

Electric fields interact with the charges in all matter, including living systems. When a conducting object, such as a vehicle or person, is located in a time-varying electric field near a transmission line, the external electric field exerts forces on the charges in the object, and electric fields and currents are induced in the object. If the object is grounded, then the total current induced in the body (the "short-circuit current") flows to earth. The distribution of the currents within, say, the human body, depends on the electrical conductivities of various parts of the body: for example, muscle and blood have higher conductivity than bone and would therefore experience higher currents.

At the boundary surface between air and the conducting object, the field in the air and perpendicular to the conductor surface is much, much larger than the field in the conductor itself. For example, the average surface field on a human standing in a 10 kV/m field is 27 kV/m; the internal fields in the body are much smaller: approximately 0.008 V/m in the torso and 0.45 V/m in the ankles.

### **3.2 Transmission-line Electric Fields**

The electric field created by a high-voltage transmission line extends from the energized conductors to other conducting objects such as the ground, towers, vegetation, buildings, vehicles, and people. The calculated strength of the electric field at a height of 3.28 ft. (1 m) above an unvegetated, flat earth is frequently used to describe the electric field under straight parallel transmission lines. The most important transmission-line parameters that determine the electric field at a 1-m height are conductor height above ground and line voltage.

Calculations of electric fields from transmission lines are performed with computer programs based on well-known physical principles (cf., Deno and Zaffanella, 1982). The calculated values under these conditions represent an ideal situation. When practical conditions approach this ideal model, measurements and calculations agree. Often, however, conditions are far from ideal because of variable terrain and vegetation. In these cases, fields are calculated for ideal conditions, with the lowest conductor clearances to provide upper bounds on the electric field under the transmission lines. With the

use of more complex models or empirical results, it is also possible to account accurately for variations in conductor height, topography, and changes in line direction. Because the fields from different sources add vectorially, it is possible to compute the fields from several different lines if the electrical and geometrical properties of the lines are known. However, in general, electric fields near transmission lines with vegetation below are highly complex and cannot be calculated. Measured fields in such situations are highly variable.

For evaluation of EMF from transmission lines, the fields must be calculated for a specific line condition. The NESC states the condition for evaluating electric-field-induced short-circuit current for lines with voltage above 98 kV, line-to-ground, as follows: conductors are at a minimum clearance from ground corresponding to a conductor temperature of 120°F (49°C), and at a maximum voltage (IEEE, 1990). BPA has supplied the needed information for calculating electric and magnetic fields from the proposed transmission lines: the maximum operating voltage, the estimated peak current in 2006, and the minimum conductor clearances.

There are standard techniques for measuring transmission-line electric fields (IEEE, 1987). Provided that the conditions at a measurement site closely approximate those of the ideal situation assumed for calculations, measurements of electric fields agree well with the calculated values. If the ideal conditions are not approximated, the measured field can differ substantially from calculated values. Usually the actual electric field at ground level is reduced from the calculated values by various common objects that act as shields.

Maximum or peak field values occur over a small area at midspan, where conductors are closest to the ground. As the location of an electric-field profile approaches a tower, the conductor clearance increases, and the peak field decreases. A grounded tower will reduce the electric field considerably by shielding. For the parallel-line configuration considered here, minimum conductor clearances were assumed to occur along the same lateral profile for both lines. This condition will not necessarily occur in practice, because the towers for the parallel lines may be offset or located at different elevations. The assumption of simultaneous minimum clearance results in peak fields that may be larger than what occurs in practice.

For traditional transmission lines, such as the proposed line, where the right-of-way extends laterally well beyond the conductors, electric fields at the edge of the right-of-way are not as sensitive as the peak field to conductor height. Computed values at the edge of the right-of-way for any line height are fairly representative of what can be expected all along the transmission-line corridor. However, the presence of vegetation on and at the edge of the right-of-way will reduce actual electric-field levels below calculated values.

### **3.3 Calculated Values of Electric Fields**

Table 3 shows the calculated values of electric field at 3.28 ft. (1 m) above ground for the proposed Santiam - Bethel 230-kV transmission-line configurations. The peak value on the right-of-way and the value at the edge of the right-of-way are given for the two proposed corridor configurations and for minimum and average conductor clearances. Figure 2a shows lateral profiles for the electric field from the proposed and existing lines for the minimum conductor heights. Figure 2b shows calculated fields for the proposed and existing lines in the configuration with a parallel 500-kV line.

The calculated peak electric field expected on the right-of-way of the proposed line is 2.5 kV/m when there are no parallel lines. As shown in Figure 2a, the peak values would be present only at locations directly under the line, near mid-span, where the conductors are at the minimum clearance. The



conditions of minimum conductor clearance at maximum current and maximum voltage occur very infrequently. The calculated peak levels are rarely reached under real-life conditions, because the actual line height is generally above the minimum value used in the computer model, because the actual voltage is below the maximum value used in the model, and because vegetation within and near the edge of the right-of-way tends to shield the field at ground level. Maximum electric field under the existing parallel 500-kV is 8.1 kV/m.

The largest values expected at the edge of the right-of-way nearest the proposed line would be 0.4 kV/m. For the parallel configuration, the field at the edge of the right-of-way nearest the 500-kV line would be 0.3 kV/m. The largest electric fields at the edges of the existing rights-of-way are 1.3 and 2.6 kV/m for the 230- and 500-kV lines, respectively.

### **3.4 Environmental Electric Fields**

The electric fields associated with the Santiam - Bethel line can be compared with those found in other environments. Sources of 60-Hz electric (and magnetic) fields exist everywhere electricity is used; levels of these fields in the modern environment vary over a wide range. Electric-field levels associated with the use of electrical energy are orders of magnitude greater than the naturally occurring 60-Hz fields of about 0.0001 V/m, which stem from atmospheric and extraterrestrial sources.

Electric fields in outdoor, publicly accessible places range from less than 1 V/m to 12 kV/m; the large fields exist close to high-voltage transmission lines of 500 kV or higher. In remote areas without electrical service, 60-Hz field levels can be much lower than 1 V/m. Electric fields in home and work environments generally are not spatially uniform like those of transmission lines; therefore, care must be taken when making comparisons between fields from different sources such as appliances and electric lines. In addition, fields from all sources can be strongly modified by the presence of conducting objects. However, it is helpful to know the levels of electric fields generated in domestic and office environments in order to compare commonly experienced field levels with those near transmission lines.

Numerous measurements of residential electric fields have been reported for various parts of the United States, Canada, and Europe. Although there have been no large studies of residential electric fields, sufficient data are available to indicate field levels and characteristics. Measurements of domestic 60-Hz electric fields indicate that levels are highly variable and source-dependent. Electric-field levels are not easily predicted because walls and other objects act as shields, because conducting objects perturb the field, and because homes contain numerous localized sources. Internal sources (wiring, fixtures, and appliances) seem to predominate in producing electric fields inside houses. Average measured electric fields in residences are generally in the range of 5 to 20 V/m. In a large occupational exposure monitoring project that included electric-field measurements at homes, average exposures for all groups away from work were generally less than 10 V/m (Bracken, 1990).

Electric fields from household appliances are localized and decrease rapidly with distance from the source. Local electric fields measured at 1 ft. (0.3 m) from small household appliances are typically in the range of 30 to 60 V/m. Stopps and Janischewskyj (1979) reported electric-field measurements near 20 different appliances; at a 1-ft. (0.3-m) distance, fields ranged from 1 to 150 V/m, with a mean of 33 V/m. In another survey, reported by Deno and Zaffanella (1982), field measurements at a 1-ft. (0.3-m) distance from common domestic and workshop sources were found to range from 3 to 70 V/m. The localized fields from appliances are not uniform, and care should be taken in comparing them with transmission-line fields.

Electric blankets can generate higher localized electric fields. Sheppard and Eisenbud (1977) reported fields of 250 V/m at a distance of approximately 1 ft. (0.3 m). Florig et al. (1987) carried out extensive empirical and theoretical analysis of electric-field exposure from electric blankets and presented results in terms of uniform equivalent fields such as those near transmission lines. Depending on what parameter was chosen to represent intensity of exposure and the grounding status of the subject, the equivalent vertical 60-Hz electric-field exposure ranged from 20 to over 3500 V/m. The largest equivalent field corresponds to the measured field on the chest with the blanket-user grounded. The average field on the chest of an ungrounded blanket-user yields an equivalent vertical field of 960 V/m. As manufacturers have become aware of the controversy surrounding EMF exposures, electric blankets have been redesigned to reduce magnetic fields. However, electric fields from these “low field” blankets are still comparable with those from older designs (Bassen et al., 1991).

Generally, people in occupations not directly related to high-voltage equipment are exposed to electric fields comparable with those of residential exposures. For example, the average electric field measured in 14 commercial and retail locations in rural Wisconsin and Michigan was 4.8 V/m (ITT Research Institute, 1984). Median electric field was about 3.4 V/m. These values are about one-third the values in residences reported in the same study. Power-frequency electric fields near video display terminals (VTDs) are about 10 V/m, similar to those of other appliances (Harvey, 1983). Electric-field levels in public buildings such as shops, offices, and malls appear to be comparable with levels in residences.

In a survey of 1,882 volunteers from utilities, electric-field exposures were measured for 2,082 work days and 657 non-work days (Bracken, 1990). Electric-field exposures for occupations other than those directly related to high-voltage equipment were equivalent to those for non-work exposure.

Thus, except for the relatively few occupations where high-voltage sources are prevalent, electric fields encountered in the workplace are probably similar to those of residential exposures. Even in electric-utility occupations where high field sources are present, exposures to high fields are limited on average to minutes per day.

Electric fields found in publicly accessible areas near high-voltage transmission lines can typically range up to 3 kV/m for 230-kV lines, to 10 kV/m for 500-kV lines, and to 12 kV/m for 765-kV lines. Although these peak levels are considerably higher than the levels found in other public areas, they are present only in limited areas on rights-of-way.

The calculated electric fields for the proposed Santiam - Bethel 230-kV transmission line are consistent with the levels reported for other 230-kV transmission lines in Oregon and elsewhere. The electric fields on and at the edge of the right-of-way from the proposed line will be less than those from the Santiam - Chemawa 230-kV line that would be replaced. Electric fields from the existing 500-kV line will remain the same and be larger than those from the proposed or existing 230-kV lines. The calculated electric fields on the right-of-way of the proposed transmission line would be much higher than levels normally encountered in residences and offices.

## **4.0 Magnetic Field**

### **4.1 Basic Concepts**

Magnetic fields can be characterized by the force they exert on a moving charge or on an electrical current. As with the electric field, the magnetic field is a vector quantity characterized by both magnitude and direction. Electrical currents generate magnetic fields. In the case of transmission lines,

distribution lines, house wiring, and appliances, the 60-Hz electric current flowing in the conductors generates a time-varying, 60-Hz magnetic field in the vicinity of these sources. The strength of a magnetic field is measured in terms of magnetic lines of force per unit area, or magnetic flux density. The term “magnetic field,” as used here, is synonymous with magnetic flux density and is expressed in units of Gauss (G) or milligauss (mG).

The uniformity of a magnetic field depends on the nature and proximity of the source, just as the uniformity of an electric field does. Transmission-line-generated magnetic fields are quite uniform over horizontal and vertical distances of several feet near the ground. However, for small sources such as appliances, the magnetic field decreases rapidly over distances comparable with the size of the device.

The interaction of a time-varying magnetic field with conducting objects results in induced electric field and currents in the object. A changing magnetic field through an area generates a voltage around any conducting loop enclosing the area (Faraday's law). This is the physical basis for the operation of an electrical transformer. For a time-varying sinusoidal magnetic field, the magnitude of the induced voltage around the loop is proportional to the area of the loop, the frequency of the field, and the magnitude of the field. The induced voltage around the loop results in an induced electric field and current flow in the loop material. The induced current that flows in the loop depends on the conductivity of the loop.

## **4.2 Transmission-line Magnetic Fields**

The magnetic field generated by currents on transmission-line conductors extends from the conductors through the air and into the ground. The magnitude of the field at a height of 3.28 ft. (1 m) is frequently used to describe the magnetic field under transmission lines. Because the magnetic field is not affected by non-ferrous materials, the field is not influenced by normal objects on the ground under the line. The direction of the maximum field varies with location. (The electric field, by contrast, is essentially vertical near the ground.) The most important transmission-line parameters that determine the magnetic field at 3.28 ft. (1 m) height are conductor height above ground and magnitude of the currents flowing in the conductors. As distance from the transmission-line conductors increases, the magnetic field decreases.

Calculations of magnetic fields from transmission lines are performed using well-known physical principles (cf., Deno and Zaffanella, 1982). The calculated values usually represent the ideal straight parallel-conductor configuration. For simplicity, a flat earth is usually assumed. Balanced currents (currents of the same magnitude for each phase) are also assumed. This is usually valid for transmission lines, where loads on all three phases are maintained in balance during operation. Induced image currents in the earth are usually ignored for calculations of magnetic field under or near the right-of-way. The resulting error is negligible. Only at distances greater than 300 ft. (91 m) from a line do such contributions become significant (Deno and Zaffanella, 1982). The clearance for magnetic-field calculations for the proposed line was the same as that used for electric-field evaluations.

Standard techniques for measuring magnetic fields near transmission lines are described in ANSI IEEE Standard No. 644-1987 (1987). Measured magnetic fields agree well with calculated values, provided the currents and line heights that go into the calculation correspond to the actual values for the line. To realize such agreement, it is necessary to get accurate current readings during field measurements (because currents on transmission lines can vary considerably over short periods of time) and also to account for all field sources in the vicinity of the measurements.

As with electric fields, the maximum or peak magnetic fields occur in areas near the centerline and at midspan where the conductors are the lowest. The magnetic field at the edge of the right-of-way is not very dependent on line height. If more than one line is present, the peak field will depend on the relative electrical phasing of the conductors and the direction of power flow. Phasing information was available for the parallel 500-kV line. Phasing of the proposed line was selected to minimize magnetic field at the edge of the right-of-way.

### 4.3 Calculated Values for Magnetic Fields

Table 4 gives the calculated values of the magnetic field at 3.28 ft. (1 m) height for the proposed 230-kV transmission-line corridor. Field values on the right-of-way and at the edge of the right-of-way are given for projected maximum currents during winter peak load in 2006, for minimum and average conductor clearances. The maximum currents are 755 A on each of the three phases of the proposed Santiam - Bethel 230-kV line and 644 A on the rebuilt Santiam - Chemawa 230-kV line. Figure 3 shows lateral profiles of maximum magnetic field under this current condition for the two possible corridors of the proposed 230-kV transmission line. The actual magnetic-field levels would vary, as currents on the lines change daily and seasonally and as ambient temperature changes. Average currents over the year would be about 60% of the maximum values. The levels shown in the figures represent the highest magnetic fields expected for the proposed Santiam - Bethel/Santiam - Chemawa 230-kV line. Average fields over a year would be considerably reduced from the peak values, as a result of increased clearances above the minimum value and reduced currents from the maximum value.

The maximum calculated 60-Hz magnetic field expected at 3.28 ft. (1 m) above ground for the proposed line is 87 mG for the proposed line alone and 94 mG when the line parallels the 500-kV line. This field is calculated for the maximum current of 755 A, with the conductors at a height of 31 ft. (9.5 m). The maximum field would decrease for increased conductor clearance. For an average conductor height over a span of 43 ft. (13.1 m), the maximum field would be 50 mG and 58 mG for the proposed line alone and parallel to the 500-kV line, respectively.

At the edge of the right-of-way of the proposed line, the calculated magnetic field for maximum current load conditions is 26 mG. When the line is located parallel to the existing 500-kV line, the field at the edge of the right-of-way adjacent to the proposed line would be 29 mG.

The magnetic field falls off rapidly as distance from the line increases. At a distance of 200 ft. (61 m) from the centerline of the proposed line, the field would be 4 mG for maximum current conditions. The calculated magnetic field for maximum current would be less than 10 mG at about 120 ft. (37 m) from the centerline.

The calculated fields for the two corridors with existing transmission lines are given in Table 4. For the existing lines, the peak magnetic fields on the rights-of-way are 218 mG and 108 mG, for the 230- and 500-kV lines, respectively. Fields at the edges of the existing rights-of-way are 78 mG and 50 mG for the 230- and 500-kV lines, respectively. Addition of the proposed line will not significantly change the magnetic fields under, or at the edge of, the right-of-way of the existing 500-kV line.

### 4.4 Environmental Magnetic Fields

Transmission lines are not the only source of magnetic fields; as with 60-Hz electric fields, 60-Hz magnetic fields are present throughout the environment of a society that relies on electricity as a principal energy source. The magnetic fields associated with the proposed Santiam - Bethel 230-kV line can be compared with fields from other sources. The range of 60-Hz magnetic-field exposures in publicly

accessible locations such as open spaces, transmission-line rights-of-way, streets, pedestrian walkways, parks, shopping malls, parking lots, shops, hotels, public transportation, and so on range from less than 0.1 mG to about 1 G, with the highest values occurring near small appliances with electric motors. In occupational settings in electric utilities, where high currents are present, magnetic-field exposures for workers can be above 1 G. At 60 Hz, the magnitude of the natural magnetic field is approximately 0.0005 mG.

Several investigations of residential fields have been conducted. In a large study to identify and quantify significant sources of 60-Hz magnetic fields in residences, measurements were made in 996 houses, randomly selected throughout the country (Zaffanella, 1993). The most common sources of residential fields were power lines, the grounding system of residences, and appliances. Field levels were characterized by both point-in-time (spot) measurements and 24-hour measurements. Spot measurements averaged over all rooms in a house exceeded 0.6 mG in 50% of the houses and 2.9 mG in 5% of houses. Power lines generally produced the largest average fields in a house over a 24-hour period. On the other hand, grounding system currents proved to be a more significant source of the highest fields in a house. Appliances were found to produce the highest local fields; however, fields fell off rapidly with increased distance. For example, the median field near microwave ovens was 36.9 mG at a distance of 10.5 in. (0.27 m) and 2.1 mG at 46 in. (1.17 m). Across the entire sample of 996 houses, higher magnetic fields were found in, among others, urban areas (vs. rural); multi-unit dwellings (vs. single-family); old houses (vs. new); and houses with grounding to a municipal water system.

In an extensive measurement project to characterize the magnetic-field exposure of the general population, over 1000 randomly selected persons in the United States wore a personal exposure meter for 24 hours and recorded their location in a simple diary (Zaffanella and Kalton, 1998). Based on the measurements of 853 persons, the estimated 24-hour average exposure for the general population is 1.24 mG and the estimated median exposure is 0.88 mG. The average field "at home, not in bed" is 1.27 mG and "at home, in bed" is 1.11 mG. Average personal exposures were found to be largest "at work" (mean of 1.79 mG and median of 1.01 mG) and lowest "at home, in bed" (mean of 1.11 mG and median of 0.49 mG). Average fields in school were also low (mean of 0.88 mG and median of 0.69 mG). Factors associated with higher exposures at home were smaller residences, duplexes and apartments, metallic rather than plastic water pipes, and nearby overhead distribution lines.

As noted above, magnetic fields from appliances are localized and decrease rapidly with distance from the source. Localized 60-Hz magnetic fields have been measured near about 100 household appliances such as ranges, refrigerators, electric drills, food mixers, and shavers (Gauger, 1985). At a distance of 1 ft. (0.3 m), the maximum magnetic field ranged from 0.3 to 270 mG, with 95% of the measurements below 100 mG. Ninety-five percent of the levels at a distance of 4.9 ft. (1.5 m) were less than 1 mG. Devices that use light-weight, high-torque motors with little magnetic shielding exhibited the largest fields. These included vacuum cleaners and small hand-held appliances and tools. Microwave ovens with large power transformers also exhibited relatively large fields. Electric blankets have been a much-studied source of magnetic-field exposure because of the length of time they are used and because of the close proximity to the body. Florig and Hoburg (1988) estimated that the average magnetic field in a person using an electric blanket was 15 mG, and that the maximum field could be 100 mG. New "low-field" blankets have magnetic fields at least 10 times lower than those from conventional blankets (Bassen et al., 1991).

In a domestic magnetic-field survey, Silva et al. (1989) measured fields near different appliances at locations typifying normal use (e.g., sitting at a typewriter or standing at a stove). Specific appliances with relatively large fields included can openers (n = 9), with typical fields ranging from 30 to 225 mG and a maximum value up to 2.7 G; shavers (n = 4), with typical fields from 50 to 300 mG and maximum

fields up to 6.9 G; and electric drills ( $n = 2$ ), with typical fields from 56 to 190 mG and maximum fields up to 1.5 G. The fields from such appliances fall off very rapidly with distance and are only present for short periods. Thus, although instantaneous magnetic-field levels close to small hand-held appliances can be quite large, they do not contribute to average area levels in residences.

Although studies of residential magnetic fields have not all considered the same independent parameters, the following consistent characterization of residential magnetic fields emerges from the data:

- (1) External sources play a large role in determining residential magnetic-field levels. Transmission lines, when nearby, are an important external source. Unbalanced ground currents on neutral conductors and other conductors, such as water pipes in and near a house, can represent a significant source of magnetic field. Distribution lines per se, unless they are quite close to a residence, do not appear to be a traditional distance-dependent source.
- (2) Homes with overhead electrical service appear to have higher average fields than those with underground service.
- (3) Appliances represent a localized source of magnetic fields that can be much higher than average or area fields. However, fields from appliances approach area levels at distances greater than 3 ft. (1 m) from the device.

Although important variables in determining residential magnetic fields have been identified, quantification and modeling of their influence on fields at specific locations is not yet possible. However, a general characterization of residential magnetic-field level is possible: average levels in the United States are in the range of 0.5 to 1.0 mG, with the average field in a small number of homes exceeding this range by as much as a factor of 10 or more. Average personal exposure levels are slightly higher, possibly due to use of appliances and varying distances to other sources. Maximum fields can be much higher.

Magnetic fields in commercial and retail locations are comparable with those in residences. As with appliances, certain equipment or machines can be a local source of higher magnetic fields. Utility workers who work close to transformers, generators, cables, transmission lines, and distribution systems clearly experience high-level fields. Other sources of fields in the workplace include motors, welding machines, computers, and video display terminals (VDTs). In publicly accessible indoor areas, such as offices and stores, field levels are generally comparable with residential levels, unless a high-current source is nearby.

Because high-current sources of magnetic field are more prevalent than high-voltage sources, occupational environments with relatively high magnetic fields encompass a more diverse set of occupations than do those with high electric fields. For example, in occupational magnetic-field measurements reported by Bowman et al. (1988), the geometric mean field from 105 measurements of magnetic field in "electrical worker" job locations was 5.0 mG. "Electrical worker" environments showed the following elevated magnetic-field levels (geometric mean greater than 20 mG): industrial power supplies, alternating current (ac) welding machines, and sputtering systems for electronic assembly. For secretaries in the same study, the geometric mean field was 3.1 mG for those using VDTs ( $n = 6$ ) and 1.1 mG for those not using VDTs ( $n = 3$ ).

Measurements of personal exposure to magnetic fields were made for 1,882 volunteer utility workers for a total of 4,411 workdays (Bracken, 1990). Median workday mean exposures ranged from 0.5 mG for clerical workers without computers to 7.2 mG for substation operators. Occupations not specifically associated with transmission and distribution facilities had median workday exposures less than 1.5 mG,

while those associated with such facilities had median exposures above 2.3 mG. Magnetic-field exposures measured in homes during this study were comparable with those recorded in offices.

Magnetic fields in publicly accessible outdoor areas seem to be, as expected, directly related to proximity to electric-power transmission and distribution facilities. Near such facilities, magnetic fields are generally higher than indoors (residential). Higher-voltage facilities tend to have higher fields. Typical maximum magnetic fields in publicly accessible areas near transmission facilities can range from less than a few milligauss up to 300 mG or more, near heavily loaded lines operated at 230 to 765 kV. The levels depend on the line load, conductor height, and location on the right-of-way. Because magnetic fields near high-voltage transmission lines depend on the current in the line, they can vary daily and seasonally. To characterize fields from the distribution system, Heroux (1987) measured 60-Hz magnetic fields with a mobile platform along 140 mi. (223 km) of roads in Montreal. The median field level averaged over nine different routes was 1.6 mG, with 90% of the measurements less than about 5.1 mG. Spot measurements indicated that typical fields directly above underground distribution systems were 5 to 19 mG. Beneath overhead distribution lines, typical fields were 1.5 to 5 mG on the primary side of the transformer, and 4 to 10 mG on the secondary side. Near ground-based transformers used in residential areas, fields were 80 to 1000 mG at the surface and 10 to 100 mG at a distance of 1 ft. (0.3 m).

The magnetic fields from the proposed 230-kV transmission line would be less than those from the existing 230-kV line that is being replaced. The fields from the proposed line would be comparable to or less than those from existing 230-kV lines in Oregon and elsewhere. On and near the right-of-way of the proposed line, magnetic fields would be well above average residential levels. However, the fields from the line would decrease rapidly and approach common ambient levels at distances greater than a few hundred feet from the line. Furthermore, the fields at the edge of the right-of-way would not be above those encountered during normal activities near common sources such as hand-held appliances.

## **5.0 Electric and Magnetic Field (EMF) Effects**

Possible effects associated with the interaction of EMF from transmission lines with people on and near a right-of-way fall into two categories: short-term effects that can be perceived and may represent a nuisance, and possible long-term health effects. Only short-term effects are discussed here. The issue of whether there are long-term health effects associated with transmission-line fields is controversial. In recent years, considerable research on possible biological effects of EMF has been conducted. A review of these studies and their implications for health-related effects is provided in a separate technical report for the environmental assessment for the proposed Santiam - Bethel 230-kV transmission line.

### **5.1 Electric Fields: Short-term Effects**

Short-term effects from transmission-line electric fields are associated with perception of induced currents and voltages or perception of the field. Induced current or spark discharge shocks can be experienced under certain conditions when a person contacts objects in an electric field. Such effects occur in the fields associated with transmission lines that have voltages of 230-kV or higher. These effects could occur infrequently under the proposed Santiam - Bethel 230-kV line. The higher electric fields under the existing 500-kV Marion-Santiam line are much more likely to result in such effects.

Steady-state currents are those that flow continuously after a person contacts an object and provides a path to ground for the induced current. The amplitude of the steady-state current depends on the induced current to the object in question and on the grounding path. The magnitude of the induced current to vehicles and objects under the proposed line will depend on the electric-field strength and the size and

shape of the object. When an object is electrically grounded, the voltage on the object is reduced to zero, and it is not a source of current or voltage shocks. If the object is poorly grounded or not grounded at all, then it acquires some voltage relative to earth and is a possible source of current or voltage shocks.

The responses of persons to steady-state current shocks have been extensively studied, and levels of response documented (Keesey and Letcher, 1969; IEEE, 1978). Primary shocks are those that can result in direct physiological harm. Such shocks will not be possible from induced currents under the existing or proposed lines, because clearances above ground required by the NESC preclude such shocks from large vehicles and grounding practices eliminate large stationary objects as sources of such shocks.

Secondary shocks are defined as those that could cause an involuntary and potentially harmful movement, but no direct physiological harm. Secondary shocks could occur under the proposed 230-kV line when making contact with ungrounded conducting objects such as vehicles or equipment. However, such occurrences are anticipated to be very infrequent. Shocks, when they occur under the 230-kV line, are most likely to be below the nuisance level. Induced currents are extremely unlikely to be perceived off the right-of-way of the proposed line.

Induced currents are always present in electric fields under transmission lines and will be present near the proposed line. However, during initial construction, BPA routinely grounds metal objects that are located on or near the right-of-way. The grounding eliminates these objects as sources of induced current and voltage shocks. Multiple grounding points are used to provide redundant paths for induced current flow. After construction, BPA would respond to any complaints and install or repair grounding to mitigate nuisance shocks.

Unlike fences or buildings, mobile objects such as vehicles and farm machinery cannot be grounded permanently. Limiting the possibility of induced currents from such objects to persons is accomplished in several ways. First, required clearances for above-ground conductors tend to limit field strengths to levels that do not represent a hazard or nuisance. The NESC (IEEE, 1990) requires that, for lines with voltage exceeding 98 kV line-to-ground (170 kV line-to-line), sufficient conductor clearance be maintained to limit the induced short-circuit current in the largest anticipated vehicle under the line to 5 milliamperes (mA) or less. This can be accomplished by limiting access or by increasing conductor clearances in areas where large vehicles could be present. BPA and other utilities design and operate lines to be in compliance with the NESC.

For the proposed line, conductor clearances (50°C conductor temperature) would be increased to at least 39 ft. (11.9 m) over road crossings along the route, resulting in a maximum field of 1.7 kV/m or less at the 3.28 ft. (1 m) height. The largest truck allowed on roads in Oregon without a special permit is 14 feet high by 8.5 feet wide by 75 feet long (4.3 x 2.6 x 22.9 m). The induced currents to such a vehicle oriented perpendicular to the line in a maximum field of 1.7 kV/m (at 3.28-foot height) would be less than 1.5 mA (Reilly, 1979). For smaller trucks, the maximum induced currents for perpendicular orientation to the proposed line would be less than this value. (Larger special-permitted trucks, such as triple trailers, can be up to 105 feet in length. However, because they average the field over such a long distance, the maximum induced current to a 105-foot vehicle oriented perpendicular to the 230-kV line at a road crossing would be less than 1.4 mA.) Thus, the NESC 5-mA criterion would be met for perpendicular road crossings of the proposed line. These large vehicles are not anticipated to be off highways or oriented parallel to the proposed line. Even if they were, the NESC 5-mA criterion would be met under the proposed line. As discussed below, these are worst-case estimates of induced currents at road crossings; conditions for their occurrence are rare. The conductor clearance at each road crossing would be checked during the design stage of the line to ensure that the NESC 5-mA criterion is met. Furthermore, it is BPA policy to limit the maximum induced current from vehicles to 2 mA in



commercial parking lots. Line clearances would also be increased in accordance with the NESC, such as over railroads and water areas suitable for sailboating.

Several factors tend to reduce the levels of induced current shocks from vehicles:

- (1) Activities are distributed over the whole right-of-way, and only a small percentage of time is spent in areas where the field is at or close to the maximum value.
- (2) At road crossings, vehicles are aligned perpendicular to the conductors, resulting in a substantial reduction in induced current.
- (3) The conductor clearance at road crossings may not be at minimum values because of lower conductor temperatures and/or location of the road crossing away from midspan.
- (4) The largest vehicles are permitted only on certain highways.
- (5) Off-road vehicles are in contact with soil or vegetation, which reduces shock currents substantially.

Induced voltages occur on objects, such as vehicles, in an electric field where there is an inadequate electrical ground. If the voltage is sufficiently high, then a spark discharge shock can occur as contact is made with the object. Such shocks are similar to "carpet" shocks that occur, for example, when a person touches a doorknob after walking across a carpet on a dry day.

In electric fields higher than will occur under the proposed line, it is theoretically possible for a spark discharge from the induced voltage on a large vehicle to ignite gasoline vapor during refueling. The probability for exactly the right conditions to occur for ignition is extremely remote. The additional clearance of conductors provided at road crossings reduces the electric field in areas where vehicles are prevalent and reduces the chances for such events. Even so, BPA recommends that vehicles should not be refueled under the proposed line unless specific precautions are taken to ground the vehicle and the fueling source (USDOE, 1995).

Under certain conditions, the electric field can be perceived through hair movement on an upraised hand or arm of a person standing on the ground under high-voltage transmission lines. The median field for perception in this manner was 7 kV/m for 136 persons; only about 12% could perceive fields of 2 kV/m or less (Deno and Zaffanella, 1982). Even in areas under the conductors at midspan, the fields at ground level would be below the levels where field perception normally occurs. Therefore, it is unlikely that the field would be perceived anywhere on the right-of-way. Where vegetation provides shielding, the field would not be perceived.

Conductive shielding reduces both the electric field and induced effects such as shocks. Persons inside a vehicle cab or canopy are shielded from the electric field. Similarly, a row of trees or a lower-voltage distribution line reduces the field on the ground in the vicinity. Metal pipes, wiring, and other conductors in a residence or building shield the interior from the transmission-line electric field.

Thus, potential impacts of electric fields can be mitigated through grounding policies, adherence to the NESC, and increased clearances above the minimums specified by the NESC. Worst-case levels are used for safety analyses but, in practice, induced currents and voltages are reduced considerably by unintentional grounding. Shielding by conducting objects, such as vehicles and vegetation, also reduces the potential for electric-field effects.

The electric fields from the proposed 230-kV line will be less than those from the line it is replacing. Therefore the potential for impacts of electric fields will be reduced from that now present on the existing right-of-way. The potential for effects from the parallel 500-kV line will remain the same.

## **5.2 Magnetic Field: Short-term Effects**

Magnetic fields associated with transmission and distribution systems can induce voltage and current in long conducting objects that are parallel to the transmission line. As with electric-field induction, these induced voltages and currents are a potential source of shocks. A fence, irrigation pipe, pipeline, electrical distribution line, or telephone line forms a conducting loop when it is grounded at both ends. The earth forms the other portion of the loop. The magnetic field from a transmission line can induce a current to flow in such a loop if it is oriented parallel to the line. If only one end of the fence is grounded, then an induced voltage appears across the open end of the loop. The possibility for a shock exists if a person closes the loop at the open end by contacting both the ground and the conductor. The magnitude of this potential shock depends on the following factors: the magnitude of the field; the length of the object (the longer the object, the larger the induced voltage); the orientation of the object with respect to the transmission line (parallel as opposed to perpendicular, where no induction would occur); and the amount of electrical resistance in the loop (high resistance limits the current flow).

Magnetically induced currents from power lines have been investigated for many years; calculation methods and mitigating measures are available. A comprehensive study of gas pipelines near transmission lines developed prediction methods and mitigation techniques specifically for induced voltages on pipelines (Dabkowski and Taflove, 1979; Taflove and Dabkowski, 1979). Similar techniques and procedures are available for irrigation pipes and fences. Grounding policies employed by utilities for long fences reduce the potential magnitude of induced voltage.

The magnitude of the coupling with both pipes and fences is very dependent on the electrical unbalance (unequal currents) among the three phases of the line. Thus, a distribution line where a phase outage may go unnoticed for long periods of time can represent a larger source of induced currents than a transmission line where the loads are well-balanced (Jaffa and Stewart, 1981).

Knowledge of the phenomenon, grounding practices, and the availability of mitigation measures mean that magnetic-induction effects from the proposed 230-kV transmission line will be minimal.

Magnetic fields from transmission and distribution facilities can interfere with certain electronic equipment. Magnetic fields can cause distortion of the image on VDTs and computer monitors. The threshold field for interference depends on the type and size of monitor and the frequency of the field. Interference has been observed for certain monitors at fields at or below 10 mG (Baishiki et al., 1990; Banfai et al., 2000). Generally, the problem arises when computer monitors are in use near electrical distribution facilities in large office buildings. Fields from the proposed line would fall below this level at approximately 120 ft. (37 m) from the centerline.

Interference from magnetic fields can be eliminated by shielding the affected monitor or moving it to an area with lower fields. Similar mitigation methods could be applied to other sensitive electronics, if necessary. Interference from 60-Hz fields with computers and control circuits in vehicles and other equipment is not anticipated at the field levels found under and near the proposed 230-kV transmission line.

The magnetic fields from the proposed line will be less than those from the existing line that is being replaced. Therefore the potential for impacts from magnetic fields will be reduced from that on the existing right-of-way. The potential for effects from the parallel 500-kV line will remain the same.

## **6.0 Regulations**

Regulations that apply to transmission-line electric and magnetic fields fall into two categories. Safety standards or codes are intended to limit or eliminate electric shocks that could seriously injure or kill persons. Field limits or guidelines are intended to limit electric- and magnetic-field exposures that can cause nuisance shocks or might cause health effects. In no case has a limit or standard been established because of a known or demonstrated health effect.

The proposed line would be designed to meet the NESC (IEEE, 1990), which specifies how far transmission-line conductors must be from the ground and other objects. The clearances specified in the code provide safe distances that prevent harmful shocks to workers and the public. In addition, people who live and work near transmission lines must be aware of safety precautions to avoid electrical (which is not necessarily physical) contact with the conductors. For example, farmers should not up-end irrigation pipes under a transmission or other electrical line. In addition, as a matter of safety, the NESC specifies that electric-field-induced currents from transmission lines must be below the 5 mA (“let go”) threshold deemed a lower limit for primary shock. BPA publishes and distributes a brochure that describes safe practices to protect against shock hazards around power lines (USDOE, 1995).

Field limits or guidelines have been adopted in several states and countries and by national and international organizations. Electric-field limits have generally been based on minimizing nuisance shocks or field perception. The intent of magnetic-field limits has been to limit exposures to existing levels, given the uncertainty of their potential for health effects.

There are currently no national standards in the United States for 60-Hz electric and magnetic fields. Several states have been active in establishing mandatory or suggested limits on 60-Hz electric and (in two cases) magnetic fields. Six states have specific electric-field limits that apply to transmission lines: Florida, Minnesota, Montana, New Jersey, New York, and Oregon. Florida and New York have established regulations for magnetic fields. These regulations are summarized in Table 5, adapted from TDHS Report (1989).

Electric-field limits for the states have been given in terms of maximum field or edge-of-right-of-way field, or both. The Oregon limit of 9 kV/m for electric fields is applied to areas accessible to the public (Oregon, 1980). The Oregon rule, which is found in transmission-line siting procedures also addresses grounding practices, audible noise, and radio interference.

Government agencies and utilities operating transmission systems have established design criteria that include EMF levels. BPA has maximum allowable electric fields of 9 and 5 kV/m on and at the edge of the right-of-way, respectively (USDOE, 1996). BPA also has maximum-allowable electric field strengths of 5 kV/m, 3.5 kV/m, and 2.5 kV/m for road crossings, shopping center parking lots, and commercial/industrial parking lots, respectively. These levels are based on limiting the maximum short-circuit currents from anticipated vehicles to less than 1 mA in shopping center lots and to less than 2 mA in commercial parking lots.

Electric-field limits for overhead power lines have also been established in other countries (Maddock, 1992). Limits for magnetic fields from overhead power lines have not been explicitly established

anywhere except in Florida and New York. However, general guidelines and limits on EMF have been established for occupational and public exposure in several countries and by national and international organizations.

The American Conference of Governmental Industrial Hygienists (ACGIH) sets guidelines (Threshold Limit Values or TLV) for occupational exposures to environmental agents (ACGIH, 2000). In general, a TLV represents the level below which it is believed that nearly all workers may be exposed repeatedly without adverse health effects. For EMF, the TLVs represent ceiling levels. For 60-Hz electric fields, occupational exposures should not exceed the TLV of 25 kV/m. However, the ACGIH also recognizes the potential for startle reactions from spark discharges and short-circuit currents in fields greater than 5-7 kV/m, and recommends implementing grounding practices. They recommend the use of conductive clothing for work in fields exceeding 15 kV/m. The TLV for occupational exposure to 60-Hz magnetic fields is a ceiling level of 10 G (10,000 mG) (ACGIH, 2000).

Electric and magnetic fields from various sources (including automobile ignitions, appliances, and, possibly, transmission lines) can interfere with implanted cardiac pacemakers. In light of this potential problem, manufacturers design devices to be immune from such interference. However, research has shown that these efforts have not been completely successful and that a few models of pacemakers could be affected by 60-Hz fields from transmission lines. There were also numerous models of pacemakers that were not affected by fields even larger than those found under transmission lines. Because of the known potential for interference with pacemakers by 60-Hz fields, field limits for pacemaker wearers have been established by the ACGIH. They recommend that wearers of pacemakers and similar medical-assist devices limit their exposure to electric fields of 1 kV/m or less and to magnetic fields to 1 G (1,000 mG) or less (ACGIH, 2000).

The International Committee on Non-ionizing Radiation Protection (ICNIRP), working in cooperation with the World Health Organization (WHO) has developed guidelines for occupational and public exposures to EMF (ICNIRP, 1998). For occupational exposures at 60 Hz, the recommended limits to exposure are 8.3 kV/m for electric fields and 4.2 G (4,200 mG) for magnetic fields. The electric-field level can be exceeded, provided precautions are taken to prevent spark discharge and induced current shocks. For the general public, the ICNIRP guidelines recommend exposure limits of 4.2 kV/m for electric fields and 0.83 G (830 mG) for magnetic fields (ICNIRP, 1998).

ICNIRP has also established guidelines for contact currents, which could occur when a grounded person contacts an ungrounded object in an electric field. The guideline levels are 1.0 mA for occupational exposure and 0.5 mA for public exposure.

The estimated peak electric field and magnetic field on, and at the edge of, the right-of-way of the proposed transmission line would meet limits set in all states, including Oregon. The electric fields from the proposed 230-kV line would meet the ACGIH standards, provided wearers of pacemakers and similar medical-assist devices are discouraged from unshielded right-of-way use. (A passenger in an automobile under the line would be shielded from the electric field.) The electric fields from the proposed line would meet the ICNIRP guideline for public exposure. The magnetic fields from the proposed line would be below the ACGIH and IRPA/INIRC limits. The electric fields present on the right-of-way could induce currents in ungrounded vehicles that exceeded the ICNIRP level of 0.5 mA.

## **7.0 Audible Noise**

### **7.1 Basic Concepts**

Audible noise (AN), as defined here, represents an unwanted sound, as from a transmission line, transformer, airport, or vehicle traffic. Sound is a pressure wave caused by a sound source vibrating or displacing air. The ear converts the pressure fluctuations into auditory sensations. AN from a source is superimposed on the background or ambient noise that is present before the source is introduced.

The amplitude of a sound wave is the incremental pressure resulting from sound above atmospheric pressure. The sound-pressure level is the fundamental measure of AN; it is generally measured on a logarithmic scale with respect to a reference pressure. The sound-pressure level (SPL) in decibels (dB) is given by:

$$\text{SPL} = 20 \log (P/P_0)\text{dB}$$

where P is the effective rms (root-mean-square) sound pressure,  $P_0$  is the reference pressure, and the logarithm (log) is to the base 10. The reference pressure for measurements concerned with hearing is usually taken as 20 micropascals (Pa), which is the approximate threshold of hearing for the human ear. A logarithmic scale is used to encompass the wide range of sound levels present in the environment. The range of human hearing is from 0 dB up to about 140 dB, a ratio of 10 million in pressure (EPA, 1978).

Logarithmic scales, such as the decibel scale, are not directly additive: to combine decibel levels, the dB values must be converted back to their respective equivalent pressure values, the total rms pressure level found, and the dB value of the total recalculated. For example, adding two sounds of equal level on the dB scale results in a 3 dB increase in sound level. Such an increase in sound pressure level of 3 dB, which corresponds to a doubling of the energy in the sound wave, is barely discernible by the human ear. It requires an increase of about 10 dB in SPL to produce a subjective doubling of sound level for humans. The upper range of hearing for humans (140 dB) corresponds to a sharply painful response (EPA, 1978).

Humans respond to sounds in the frequency range of 16 to 20,000 Hz. The human response depends on frequency, with the most sensitive range roughly between 2000 and 4000 Hz. The frequency-dependent sensitivity is reflected in various weighting scales for measuring audible noise. The A-weighted scale weights the various frequency components of a noise in approximately the same way that the human ear responds. This scale is generally used to measure and describe levels of environmental sounds such as those from vehicles or occupational sources. The A-weighted scale is also used to characterize transmission-line noise. Sound levels measured on the A-scale are expressed in units of dB(A) or dBA.

AN levels and, in particular, corona-generated audible noise (see below) vary in time. In order to account for fluctuating sound levels, statistical descriptors have been developed for environmental noise. Exceedence levels (L levels) refer to the A-weighted sound level that is exceeded for a specified percentage of the time. Thus, the  $L_5$  level refers to the noise level that is exceeded only 5% of the time.  $L_{50}$  refers to the sound level exceeded 50% of the time. Sound-level measurements and predictions for transmission lines are often expressed in terms of exceedence levels, with the  $L_5$  level representing the maximum level and the  $L_{50}$  level representing a median level.

Table 6 shows AN levels from various common sources. Clearly, there is wide variation. Noise exposure depends on how much time an individual spends in different locations. Outdoor noise generally does not contribute to indoor levels (EPA, 1974). Activities in a building or residence generally dominate interior AN levels. The amount of sound attenuation (reduction) provided by buildings is given in Table 7. Assuming that residences along the line route fall in the "warm climate, windows open" category, the typical sound attenuation provided by a house is about 12 dBA.

The BPA design criterion for corona-generated audible noise ( $L_{50}$ , foul weather) is  $50 \pm 2$  dBA at the edge of the ROW. This criterion has been interpreted by the state and BPA to meet Oregon Noise Control Regulations (Perry, 1982). The Environmental Protection Agency (EPA) has established a guideline of 55 dBA for the annual average day-night level ( $L_{dn}$ ) in outdoor areas (EPA, 1978). In computing this value, a 10 dB correction (penalty) is added to night-time noise between the hours of 10 p.m. and 7 a.m.

## 7.2 Transmission-line Audible Noise

Corona is the partial electrical breakdown of the insulating properties of air around the conductors of a transmission line. In a small volume near the surface of the conductors, energy and heat are dissipated. Part of this energy is in the form of small local pressure changes that result in audible noise. Corona-generated audible noise can be characterized as a hissing, crackling sound that, under certain conditions, is accompanied by a 120-Hz hum.

Corona-generated audible noise is of concern primarily for contemporary lines operating at voltages of 345 kV and higher during foul weather. Thus in the area where the proposed 230-kV line parallels a 500-kV line, audible noise from the higher voltage line will predominate. In other areas, the proposed 230-kV line will produce some noise under foul-weather conditions.

The conductors of high-voltage transmission lines are designed to be corona-free under ideal conditions. However, protrusions on the conductor surface—particularly water droplets on or dripping off the conductors—cause electric fields near the conductor surface to exceed corona onset levels, and corona occurs. Therefore, audible noise from transmission lines is generally a foul-weather (wet-conductor) phenomenon. Wet conductors can occur during periods of rain, fog, snow, or icing. Based on meteorologic records near the route of the proposed transmission line, such conditions are expected to occur less than 22% of the time during the year. For a few months after line construction, residual grease or oil on the conductors can cause water to bead up on the surface. This results in more corona sources and slightly higher levels of audible noise and electromagnetic interference if the line is energized. However, the new conductors "age" in a few months, and the level of corona activity decreases to the predicted equilibrium value. During fair weather, insects and dust on the conductor can also serve as sources of corona. The proposed line has been designed with 1.600-in. (4.1-cm) diameter conductors that will yield acceptable corona levels.

## 7.3 Predicted Audible Noise Levels

The predicted levels of corona-generated audible noise for the proposed line operated at a voltage of 235 kV are given in Table 8. For comparison, Table 8 also gives the calculated levels for the existing lines. Audible noise levels are calculated for average voltage and average conductor heights for fair- and foul-weather conditions. The calculated median level ( $L_{50}$ ) during foul weather at the edge of the proposed Santiam - Bethel right-of-way is about 39 dBA, which is less than that from the existing Santiam - Chemawa 230-kV line. Where the proposed Santiam - Bethel line parallels the Marion - Santiam 500-kV line, noise from the higher-voltage line will predominate and there would be no change in noise levels from existing conditions. For this configuration, the noise at the edge of the right-of-way near the proposed line would be 47 dBA.

During fair-weather conditions, which occur about 78% of the time, audible noise levels at the edge of the right-of-way would be about 20 dBA lower (if corona were present). These lower levels could be masked by ambient noise on and off the right-of-way.

## 7.4 Discussion

The calculated foul-weather corona noise levels for the proposed line would be less than those under the existing conditions and comparable to or less than those from existing 230-kV lines in Oregon. During fair weather, noise from the conductors might be perceivable on the right-of-way, but beyond the right-of-way it would likely be masked or so low as to not be perceived even during foul weather when ambient noise is higher.

Off the right-of-way, the levels of audible noise from the proposed line would be well below the 55 dBA level that can produce interference with speech outdoors. Since residential buildings provide significant sound attenuation (-12 dBA with windows open; -24 dBA with windows closed), the noise levels off the right-of-way would be well below the 45 dBA level required for interference with speech indoors and well below the 35 dBA level where sleep interference can occur (EPA, 1973; EPA, 1978). Since corona is a foul-weather phenomenon, people tend to be inside with windows possibly closed, providing additional attenuation when corona noise is present. In addition, ambient noise levels can be high during such periods (due to rain hitting foliage or buildings), and can mask corona noise.

The 39-dBA and 47-dBA levels would meet the BPA design criterion and, hence, the Oregon Noise Control Regulations for transmission lines. The 2 dBA decrease in noise at the edge of the right-of-way associated with the proposed line would probably not be discernible.

The computed annual  $L_{dn}$  level for transmission lines operating in areas with about 22% foul weather is about  $L_{dn} = L_{50} + 1$  dB (Bracken, 1987). Therefore, assuming such conditions in the Santiam - Bethel area, the estimated  $L_{dn}$  at the edge of the right-of-way would be approximately 40 or 48 dBA, which is below the EPA  $L_{dn}$  guideline of 55 dBA.

## 7.5 Conclusion

Along the proposed line route, there would be slight decreases, or no change, in the perceived noise above ambient levels during foul weather at the edges of the right-of-way. Along the existing corridor, the corona-generated noise during foul weather would be masked to some extent by naturally occurring sounds such as wind and rain on foliage. During fair weather, the noise off the right-of-way from the proposed line would probably not be detectable above ambient levels. However, noise from the existing 500-kV line could be perceived as much as under existing conditions. The noise levels from the proposed line would be below levels identified as causing interference with speech or sleep. The audible noise from the transmission line would be below EPA guideline levels and would meet the BPA design criterion that complies with the Oregon State noise regulations.

## 8.0 Electromagnetic Interference

### 8.1 Basic Concepts

Corona on transmission-line conductors can also generate electromagnetic noise in the frequency bands used for radio and television signals. The noise can cause radio and television interference (RI and TVI). In certain circumstances, corona-generated electromagnetic interference (EMI) can also affect communications systems and other sensitive receivers. Interference with electromagnetic signals by corona-generated noise is generally associated with lines operating at voltages of 345 kV or higher. This is especially true of interference with television signals. The 1.600-in. (4.1-cm) diameter conductor used

in the design of the proposed 230-kV line will mitigate corona generation and thus keep radio and television interference levels at acceptable levels.

Spark gaps on distribution lines and on low-voltage wood-pole transmission lines are a more common source of RI/TVI than is corona from high-voltage electrical systems. This gap-type interference is primarily a fair-weather phenomenon caused by loose hardware and wires. The proposed transmission line would be constructed with modern hardware that eliminates such problems and therefore minimizes gap noise. Consequently, this source of EMI is not anticipated for the proposed line.

No state has limits for either RI or TVI. In the United States, electromagnetic interference from power transmission systems is governed by the Federal Communications Commission (FCC) Rules and Regulations presently in existence (FCC, 1988). A power transmission system falls into the FCC category of "incidental radiation device," which is defined as "a device that radiates radio frequency energy during the course of its operation although the device is not intentionally designed to generate radio frequency energy." Such a device "shall be operated so that the radio frequency energy that is emitted does not cause harmful interference. In the event that harmful interference is caused, the operator of the device shall promptly take steps to eliminate the harmful interference." For purposes of these regulations, harmful interference is defined as: "any emission, radiation or induction which endangers the functioning of a radio navigation service or of other safety services or seriously degrades, obstructs or repeatedly interrupts a radio communication service operating in accordance with this chapter" (FCC, 1988: Vol II, part 15. 47CFR, Ch. 1).

Electric power companies have been able to work quite well under the present FCC rule because harmful interference can generally be eliminated. It has been estimated that more than 95% of power-line sources that cause interference are due to gap-type discharges. These can be found and completely eliminated, when required to prevent interference (USDOE, 1980). Complaints related to corona-generated interference occur infrequently. This is especially true with the advent of cable television and satellite television, which are not subject to corona-generated interference. Mitigation of corona-generated interference with conventional radio and television receivers can be accomplished in several ways, such as use of a directional antenna or relocation of an existing antenna (USDOE, 1977; USDOE, 1980; Loftness et al., 1981).

## **8.2 Radio Interference (RI)**

Radio reception in the AM broadcast band (535 to 1605 kilohertz (kHz)) is most often affected by corona-generated EMI. FM radio reception is rarely affected. Generally, only residences very near to transmission lines can be affected by RI. The IEEE Radio Noise Design Guide identifies an acceptable limit of fair-weather RI as expressed in decibels above 1 microvolt per meter (dB $\mu$ V/m) of about 40 dB $\mu$ V/m at 100 ft. (30 m) from the outside conductor (IEEE Committee Report, 1971). As a general rule, average levels during foul weather (when the conductors are wet) are 16 to 22 dB $\mu$ V/m higher than average fair-weather levels.

## **8.3 Predicted RI Levels**

Table 9 gives the predicted fair- and foul-weather RI levels at 100 ft. (30 m) from the outside conductor for the proposed 230-kV line in the two corridor configurations. Median foul-weather levels would be about 17 dB higher than the fair-weather levels. The predicted L<sub>50</sub> fair-weather level at the edge of the right-of-way is 34 dB $\mu$ V/m for 235-kV line operation; at 100 ft. (30 m) from the outside conductor, the level is 26 dB $\mu$ V/m. Predicted fair-weather L<sub>50</sub> levels are lower than that from the existing 230-kV Santiam - Chemawa 230-kV line. Predictions indicate that fair-weather RI will meet the IEEE



40 dB $\mu$ V/m criterion at distances greater than about 10 ft. (3 m) from the outside conductor of the proposed line.

#### **8.4 Television Interference (TVI)**

Corona-caused TVI occurs during foul weather and is generally of concern for transmission lines with voltages of 345 kV or above, and only for conventional receivers within about 600 ft. (183 m) of a line. As is the case for RI, gap sources on distribution and low-voltage transmission lines are the principal observed sources of TVI. The use of modern hardware and construction practices for the proposed line would minimize such sources.

#### **8.5 Predicted TVI Levels**

Table 10 shows TVI levels predicted at 100 ft. (30 m) from the outside conductor of the proposed line operating at 235 kV and from existing lines. At this distance, the foul-weather TVI level predicted for the proposed line is 10 dB $\mu$ V/m. This level is lower than that from the existing Santiam - Chemawa 230-kV line. Replacement of the existing line with the proposed line will reduce TVI levels along the right-of-way.

Other forms of TVI from transmission lines are signal reflection (ghosting) and signal blocking caused by the relative locations of the transmission structure and the receiving antenna with respect to the incoming television signal. The proposed structures are steel and larger than the existing wood structures; they could cause reflection or ghosting and affect reception in rare instances. Television systems that operate at higher frequencies, such as satellite receivers, are not affected by corona-generated TVI. Cable television systems are similarly unaffected.

Interference with television reception can be corrected by any of several approaches: improving the receiving antenna system; installing a remote antenna; installing an antenna for TV stations less vulnerable to interference; connecting to an existing cable system; or installing a translator (cf. USDOE, 1977). BPA has an active program to identify, investigate, and mitigate legitimate RI and TVI complaints. It is anticipated that any instances of TVI caused by the proposed line could be effectively mitigated.

#### **8.6 Interference with Other Devices**

Corona-generated interference can conceivably cause disruption on other communications bands such as the citizen's (CB) and mobile bands. However, mobile-radio communications are not susceptible to transmission-line interference because they are generally frequency modulated (FM). Similarly, cellular telephones operate at a frequency of about 900 MHz, which is above the frequency where corona-generated interference is prevalent. In the unlikely event that interference occurs with these or other communications, mitigation can be achieved with the same techniques used for television and AM radio interference. However, the addition of the proposed line would lower interference levels in the corridor; consequently, no impact is anticipated.

#### **8.7 Conclusion**

Predicted EMI levels for the proposed 230-kV transmission line are lower than those that already exist 230-kV lines; no impacts of corona-generated interference on radio, television, or other reception are anticipated above those already present. Furthermore, if interference should occur, there are various methods for correcting it: BPA has a program to respond to legitimate complaints.

## 9.0 Other Corona Effects

Corona is visible as a bluish glow or as bluish plumes. On the proposed 230-kV line, corona levels would be very low, so that corona on the conductors would be observable only under the darkest conditions and only with the aid of binoculars, if at all. Without a period of adaptation for the eyes and without intentional looking for the corona, it would not be noticeable.

When corona is present, the air surrounding the conductors is ionized and many chemical reactions take place, producing small amounts of ozone and other oxidants. Ozone is approximately 90% of the oxidants, while the remaining 10% is composed principally of nitrogen oxides. The national primary ambient air quality standard for photochemical oxidants, of which ozone is the principal component, is 235 micrograms/cubic meter) or 120 parts per billion. The maximum incremental ozone levels at ground level produced by corona activity on the proposed transmission line during foul weather would be much less than 1 part per billion. This level is insignificant when compared with natural levels and fluctuations in natural levels.

## 10.0 Summary

Electric and magnetic fields from the proposed transmission line have been characterized using well-known techniques accepted within the scientific and engineering community. The expected electric-field levels from the proposed line at minimum design clearance would be less than those from the existing line in the corridor and comparable to, or less than, those from other 230-kV lines in Oregon and elsewhere. The expected magnetic-field levels from the proposed line would be less than those from the existing line that would be replaced and comparable to, or less than, those from other 230-kV lines in Oregon and elsewhere.

The peak electric field expected under the proposed line would be 2.5 kV/m; the maximum value at the edge of the right-of-way would be about 0.4 kV/m. Clearances at road crossings would be increased to reduce the peak electric-field value to 1.7 kV/m.

Under maximum current conditions, the maximum magnetic fields under the proposed line would be 96 mG; at the edge of the right-of-way nearest to the proposed 230-kV line, the magnetic field would be 29 or 26 mG, depending on whether the line parallels an existing 500-kV line or not.

The electric and magnetic fields from the proposed line would meet regulatory limits for public exposure in Oregon and other states with limits. As long as cardiac pacemaker wearers are discouraged from using the right-of-way, the field levels meet the guidelines for exposure established by ACGIH and ICNIRP.

Short-term effects from transmission-line fields are well understood and can be mitigated. Nuisance shocks arising from electric-field induced currents and voltages could be perceivable on the right-of-way of the proposed line. BPA will ground permanent conducting objects during and after construction to mitigate against such occurrences. Since the fields from the proposed line are less than those from the existing line on the corridor, the potential for such effects could be reduced.

Corona-generated audible noise from the line would be less than from the existing 230-kV transmission lines on the corridor. Audible noise levels would be in compliance with noise regulations in Oregon and would be below levels specified in EPA guidelines.

Corona-generated electromagnetic interference from the proposed line would be less than that from the existing 230-kV line on the corridor and would remain below limits identified as acceptable. In the unlikely event that legitimate complaints arise, BPA has a mitigation program to identify and correct reception problems.

## List of References Cited

- ACGIH (American Conference of Governmental Industrial Hygienists). 2000. 2000 TLVs and BEIs: Threshold Limit Values for Chemical Substances and Physical Agents and Biological Exposure Indices. American Conference of Governmental Industrial Hygienists, Cincinnati. 192 pages.
- Baishiki, R.S.; Johnson, G.B.; Zaffanella, L.E.; Bracken, T.D.; Sussman, S.S.; Rauch, G.B.; and Silva, J.M. 1990. Studies of Power System Magnetic Fields: Characterization of Sources in Residential Environments, Measurement of Exposure, Influence On Computer Screens. (36-104) CIGRE, Paris, France. 10 pages.
- Banfai, B.; Karady, G.G.; Kim, C.J.; and Maracas, K.B. 2000. Magnetic field effects on CRT computer monitors. *IEEE Trans. on Power Delivery* 15, 307-312.
- Bassen, H.; Casamento, J.; and Crawl, B. 1991. Reduction of electric and magnetic field emissions from electric blankets (Meeting abstract). *In: Bioelectromagnetics Society, 13th Annual Meeting, 23-27 June, Salt Lake City. Bioelectromagnetics Society, New York, 20.*
- Bowman, J.D.; Garabrant, D.H.; Sobel, E.; and Peters, J.M. June 1988. Exposures to Extremely Low Frequency (ELF) Electromagnetic Fields in Occupations With Elevated Leukemia Rates. *Applied Industrial Hygienics*, 3(6, June):189-194.
- Bracken, T.D. 1987. Audible Noise from High Voltage Transmission Facilities. A Briefing Paper Prepared for State of Florida Department of Environmental Regulation. (DER Contract No. SP122) State of Florida Department of Environmental Regulation.
- Bracken, T.D. 1990. The EMDEX Project: Technology Transfer and Occupational Measurements, Volumes 1-3 Interim Report. EPRI Report EN-7048. (EPRI EN-7048) Electric Power Research Institute, Palo Alto, CA.
- Chartier, V.L. April 1983. Empirical Expressions for Calculating High Voltage Transmission Corona Phenomena, First Annual Seminar Technical Career Program for Professional Engineers. Bonneville Power Administration, Portland, Oregon. April 1983, 75-82.
- Chartier, V.L.; and Stearns, R.D. January 1981. Formulas for Predicting Audible Noise from Overhead High Voltage AC and DC Lines. *IEEE Transactions on Power Apparatus and Systems*, PAS-100(No. 1, January 1981):121-129.
- Dabkowski, J.; and Taflove, A. May/June 1979. Prediction Method for Buried Pipeline Voltages Due to 60 Hz AC Inductive Coupling. Part II: Field Test Verification. *IEEE Transactions on Power Apparatus and Systems*, PAS-98(3, May/June):788-794.
- Deno, D.W.; and Zaffanella, L. 1982. Field effects of overhead transmission lines and stations. Chap. 8. *In: Transmission Line Reference Book: 345 KV and Above. Second ed. (Ed: LaForest, J.J.). Electric Power Research Institute, Palo Alto, CA, 329-419.*
- EPA (Environmental Protection Agency). July 1973. Public Health and Welfare Criteria for Noise. (No. 500/9-73-002, July 27, 1973.) U.S. Environmental Protection Agency, Washington, D.C.

- EPA. 1974. Information On Levels of Environmental Noise Requisite to Protect Public Health and Welfare With an Adequate Margin of Safety. (No. PB-239 429.) U.S. Environmental Protection Agency, Washington, D.C.
- EPA. 1978. Protective Noise Levels. Condensed Version of EPA Levels Document. (No. PB82-138827) U.S Environmental Protection Agency, Washington, DC.
- FCC (Federal Communications Commission). 1988. Federal Communications Commission Rules and Regulations. 10-1-88 ed. Vol. II part 15, 47 CFR, Ch. 1.
- Florig, H.K.; and Hoburg, J.F. 1988. Electric and Magnetic Field Exposure Associated With Electric Blankets. Project Resume. Contractor's Review. U.S. Department of Energy/Electric Power Research Institute.
- Florig, H.K.; Hoburg, J.F.; and Morgan, M.G. April 1987. Electric Field Exposure from Electric Blankets. IEEE Transactions on Power Delivery, PWRD-2(2, April):527-536.
- Gauger, J. September 1985. Household Appliance Magnetic Field Survey. IEEE Transactions on Power Apparatus and Systems, 104(9, September):2436-2445.
- Harvey, S.M. 1983. Analysis of operator exposure to electric fields from video display units. Chap. 2. In Video Display Units--Characterization of Electric and Magnetic Fields. (Ontario Hydro Research Division Report # 83-503-K) (Ed: Walsh, M.L.). Ontario Hydro, Toronto, 31-56.
- Heroux, P. 1987. 60-Hz Electric and Magnetic Fields Generated By a Distribution Network. Bioelectromagnetics, 8(2):135-148.
- ICNIRP (International Committee on Non-ionizing Radiation Protection). April 1998. Guidelines for Limiting Exposure to Time-Varying Electric, Magnetic, and Electromagnetic Fields (Up to 300 GHz). Health Physics, 74(4, April):1-32.
- IEEE (Institute of Electrical and Electronics Engineers, Inc.). 1978. Electric and Magnetic Field Coupling from High Voltage AC Power Transmission Lines -- Classification of Short-Term Effects On People. IEEE Transactions on Power Apparatus and Systems, PAS-97:2243-2252.
- IEEE. 1987. IEEE Standard Procedures for Measurement of Power Frequency Electric and Magnetic Fields from AC Power Lines. ANSI/IEEE Std. 644-1987, New York, NY.
- IEEE. 1990. National Electrical Safety Code. 1990 ed. Institute of Electrical and Electronics Engineers, Inc., New York, NY. 432 pages.
- IEEE Committee Report. March/April 1971. Radio Noise Design Guide for High Voltage Transmission Lines. IEEE Transactions on Power Apparatus and Systems, PAS-90(No. 2, March/April):833-842.
- IEEE Committee Report. October 1982. A Comparison of Methods for Calculating Audible Noise of High Voltage Transmission Lines. IEEE Transactions on Power Apparatus and Systems, 101(10, October):4090-4099.
- ITT Research Institute. 1984. Representative Electromagnetic Field Intensities Near the Clam Lake (WI) and Republic (MI) ELF Facilities. Report Prepared for Naval Electronics Systems

- Command, PME 110 E Washington, D.C. 20360. (Under contract N00039-84-C0070.) ITT Research Institute, Chicago, IL. 60 pages.
- Jaffa, K.C.; and Stewart, J.B. March 1981. Magnetic Field Induction from Overhead Transmission and Distribution Power Lines On Buried Irrigation Pipelines. *IEEE Transactions on Power Apparatus and Systems*, PAS-100(3, March):990-1000.
- Keeseey, J.C.; and Letcher, F.S. 1969. Minimum Thresholds for Physiological Responses to Flow of Alternating Electric Current Through the Human Body At Power-Transmission Frequencies. (Report No. 1) Naval Medical Research Institute, Project MR 005.08-0030B, Bethesda, MD. 25 pages.
- Loftness, M.O.; Chartier, V.L.; and Reiner, G.L. 1981. EMI Correction Techniques for Transmission Line Corona. (August 18-20, 1981, pp. 351-361.) Proceedings of the 1981 IEEE International Symposium on Electromagnetic Compatibility, Boulder, CO.
- Maddock, B.J. September 1992. Guidelines and Standards for Exposure to Electric and Magnetic Fields At Power Frequencies. (Panel 2-05, CIGRE meeting August 30-September 5, 1992) CIGRE, Paris.
- Olsen, R.G.; Schennum, S.D.; and Chartier, V.L. April 1992. Comparison of Several Methods for Calculating Power Line Electromagnetic Interference Levels and Calibration With Long Term Data. *IEEE Transactions on Power Delivery*, 7(April, 1992):903-913.
- Oregon, State of. 1980. Oregon Administrative Rules Chapter 345, Division 80. Energy Facility Siting Council standards relating to public health and safety, 934-80-055.
- Perry, D. 1982. Sound Level Limits from BPA Facilities. BPA memorandum, May 26, 1982; Department of Environmental Quality, Noise Control Regulations, Chapter 340, Oregon Administrative Rules, Division 35, March 1, 1978.
- Reilly, J.P. 1979. Electric Field Induction on Long Objects—A Methodology for Transmission Line Impact Studies. *IEEE Transactions on Power Apparatus and Systems*, PAS-98(6, Nov/Dec):1841-1852.
- Sheppard, A.R.; and Eisenbud, M. 1977. Biological Effects of Electric and Magnetic Fields of Extremely Low Frequency. New York University Press, New York.
- Silva, M.; Hummon, N.; Rutter, D.; and Hooper, C. 1989. Power Frequency Magnetic Fields in the Home. *IEEE Transactions on Power Delivery*, 4:465-478.
- Stoppa, G.J.; and Janischewskyj, W. 1979. Epidemiological Study of Workers Maintaining HV Equipment and Transmission Lines in Ontario. (Canadian Electrical Association Research Report) Canadian Electrical Association, Montreal. 82 pages.
- Taflove, A.; and Dabkowski, J. May/June 1979. Prediction Method for Buried Pipeline Voltages Due to 60 Hz AC Inductive Coupling. Part I: Analysis. *IEEE Transactions on Power Apparatus and Systems*, PAS-98(3, May/June):780-787.

- TDHS Report. March 1989. EMF Rule Becomes Law; Hillsborough County Commission Challenges. Transmission/Distribution Health & Safety Report, 7(9, 31 March):1-3.
- TDHS Report. August 1990. Updates: New York. Transmission/Distribution Health & Safety Report, 8(7, 31 August):4.
- USDOE (U.S. Department of Energy), Bonneville Power Administration. March 1977. A Practical Handbook for the Location, Prevention and Correction of Television Interference from Overhead Power Lines. Portland, OR.
- USDOE, Bonneville Power Administration. May 1980. A Practical Handbook for the Correction of Radio Interference from Overhead Powerlines and Facilities. (May 1980.) Portland, OR.
- USDOE, Bonneville Power Administration. 1995. Living and Working Around High-Voltage Power Lines. (DOE/BP-799). Portland, OR. 9 pages.
- USDOE, Bonneville Power Administration. 1996. Electrical and Biological Effects of Transmission Lines: A Review. (DOE/BP 2938 December 1996 1M) Portland, OR.
- USDOE, Bonneville Power Administration. undated. "Corona and Field Effects" Computer Program (Public Domain Software). Bonneville Power Administration, P.O. Box 491-ELE, Vancouver, WA 98666.
- Zaffanella, L.E. 1993. Survey of Residential Magnetic Field Sources. Vol. 1: Goals, results, and conclusions. (EPRI TR-102759-V1, Project 3335-02) Electric Power Research Institute, Palo Alto, CA.
- Zaffanella, L.E.; and Kalton, G.W. 1998. Survey of personal magnetic field exposure, Phase II: 1000-person survey. Interim Report. EMF RAPID Program Engineering Project #6. Eneritech Consultants, Lee, MA.

## **List of Preparers**

T. Dan Bracken was the principal author of this report. He received a B.S. degree in physics from Dartmouth College and M.S. and Ph.D. degrees in physics from Stanford University. Dr. Bracken has been involved with research on and characterization of electric- and magnetic-field effects from transmission lines for over 27 years, first as a physicist with the Bonneville Power Administration (BPA) (1973 - 1980) and since then as a consultant. His firm, T. Dan Bracken, Inc., offers technical expertise in areas of electric- and magnetic-field measurements, instrumentation, environmental effects of transmission lines, exposure assessment and project management. Joseph Dudman of T. Dan Bracken, Inc., provided data entry, graphics, and clerical support in the preparation of the report.

Judith H. Montgomery of Judith H. Montgomery/Communications served as technical editor for the report. She holds an A.B. degree in English literature from Brown University, 1966; and a Ph.D. degree in American literature from Syracuse University, 1971. Dr. Montgomery has provided writing, editing, and communications services to government and industry for 20 years. Her experience includes preparation of National Environmental Policy Act documents and technical papers dealing with transmission-line environmental impact assessment and other utility-related activities.



(This page intentionally left blank.)

**Table 1: Physical and electrical characteristics of Santiam - Bethel Project corridors**

	New Line	Existing Corridors	
Configuration	I	I	II
Description	Santiam - Bethel/Santiam - Chemawa 230-kV	Santiam - Chemawa 230-kV	Marion - Santiam No. 1 & No. 2 500-kV
Voltage, kV Maximum/Average <sup>1</sup>	242/235	242/235	550/540, 0/0
Peak Current, A Existing/Proposed	-/755, -/644	1043/-	-889/-992, 0/0
Electric Phasing	B C A B C A	C B A	B B A C A C
Clearance, ft. Minimum/Average <sup>1</sup>	31/43	31/43	38/47
Centerline Distance from Santiam - Bethel, ft.	-	-	125
Centerline distance to edge of right-of-way (ROW), ft.	62.5	62.5	82.5
Tower configuration	Vertical double-circuit	Horizontal	Delta double-circuit
Phase spacing, ft.	24.5H, 40.5H 18V	27H	25.5H, 36.75V
Conductor: #/Diameter, in.	1/1.600	1/1.100	3/1.302

<sup>1</sup> Average voltage and average clearance used for corona calculations.

**Table 2: Possible corridors for Santiam - Bethel Project**

Configuration	Description of other lines in corridor with Santiam - Bethel/Santiam - Chemawa 230-kV line	Miles
I	Santiam - Bethel/Santiam - Chemawa 230-kV double-circuit line only	15.2
II	BPA Marion - Santiam 500-kV No. 1 and No. 2 double circuit line	1.5

**Table 3: Calculated electric fields for configurations of the proposed Santiam - Bethel/Santiam - Chemawa 230-kV line operated at maximum voltage.** Configurations are described in Tables 1 and 2.

a) **Configuration I: Santiam - Bethel/Santiam - Chemawa 230-kV line only**

Configuration	Proposed I		Existing	
ROW width, ft. (m)	125 (38)		125 (38)	
Line	Santiam - Bethel/Santiam - Chemawa 230-kV		Santiam - Chemawa 230-kV	
Clearance	Min.	Avg.	Min.	Avg.
Peak field, kV/m	2.5	1.5	3.0	1.8
Edge of ROW, kV/m	0.3	0.4	1.3	1.1

b) **Configuration II: Santiam - Bethel/Santiam - Chemawa 230-kV and Marion - Santiam 500-kV No. 1 and No. 2 lines**

Configuration	Proposed II				Existing			
ROW width, ft. (m)	270 (82)				270 (82)			
Line	Santiam - Bethel/ Santiam - Chemawa 230-kV		Marion - Santiam No. 1 and No. 2 500-kV		Santiam - Chemawa 230-kV		Marion - Santiam No. 1 and No. 2 500-kV	
Clearance	Min.	Avg.	Min.	Avg.	Min.	Avg.	Min.	Avg.
Peak field, kV/m	2.4	1.4	8.1	4.5	3.0	1.8	8.1	4.5
Edge of ROW, kV/m	0.3	0.3	2.5	2.6	1.3	1.1	2.5	2.6

**Table 4: Calculated magnetic fields for configurations of the proposed Santiam - Bethel/Santiam - Chemawa 230-kV line operated at maximum current.** Configurations are described in Tables 1 and 2.

a) **Configuration I: Santiam - Bethel/Santiam - Chemawa 230-kV line only**

Configuration	Proposed I		Existing	
ROW width, ft. (m)	125 (38)		125 (38)	
Line	Santiam - Bethel/Santiam - Chemawa 230-kV		Santiam - Chemawa 230-kV	
Clearance	Min.	Avg.	Min.	Avg.
Peak field, mG	87	50	218	139
Edge of ROW, mG	26	24	78	62

b) **Configuration II: Santiam - Bethel/Santiam - Chemawa 230-kV and Marion - Santiam 500-kV No. 1 and No. 2 lines**

Configuration	Proposed II				Existing			
ROW width, ft. (m)	270 (82)				270 (82)			
Line	Santiam - Bethel/ Santiam - Chemawa 230-kV		Marion - Santiam No. 1 and No. 2 500-kV		Santiam - Chemawa 230-kV		Marion - Santiam No. 1 and No. 2 500-kV	
Clearance	Min.	Avg.	Min.	Avg.	Min.	Avg.	Min.	Avg.
Peak field, mG	94	58	130	67	211	135	108	57
Edge of ROW, kV/m	29	24	52	39	80	65	50	38

**Table 5: States with transmission-line field limits**

STATE AGENCY	WITHIN RIGHT-OF-WAY	AT EDGE OF RIGHT-OF-WAY	COMMENTS
<b>a. 60-Hz ELECTRIC FIELD LIMIT, kV/m</b>			
Florida Department of Environmental Regulation	8 ( 230 kV) 10 (500 kV)	2	Codified regulation, adopted after a public rulemaking hearing in 1989.
Minnesota Environmental Quality Board	8	–	12-kV/m limit on the High-Voltage Direct Current (HVDC) nominal electric field.
Montana Board of Natural Resources and Conservation	7 <sup>1</sup>	1 <sup>2</sup>	Codified regulation, adopted after a public rulemaking hearing in 1984.
New Jersey Department of Environmental Protection	–	3	Used only as a guideline for evaluating complaints.
New York State Public Service Commission	11.8 (7,11) <sup>1</sup>	1.6	Explicitly implemented in terms of a specified right-of-way width.
Oregon Facility Siting Council	9	–	Codified regulation, adopted after a public rulemaking hearing in 1980.
<b>b. 60-Hz MAGNETIC FIELD LIMIT, mG</b>			
Florida Department of Environmental Regulation	–	150 ( 230 kV) 200 (500 kV)	Codified regulations, adopted after a public rulemaking hearing in 1989.
New York State Public Service Commission	–	200	Adopted August 29, 1990.

- 1 At road crossings
- 2 Landowner may waive limit

Sources: TDHS Report, 1989;TDHS Report, 1990

**Table 6: Common noise levels**

Sound Level, dBA	Noise Source or Effect
128	Threshold of pain
108	Rock-and-roll band
80	Truck at 50 ft. (15.2 m)
70	Gas lawnmower at 100 ft. (30 m)
60	Normal conversation indoors
50	Moderate rainfall on foliage
50	Edge of 500-kV right-of-way during rain
40	Refrigerator
25	Bedroom at night
0	Hearing threshold

Adapted from: USDOE, 1996.

**Table 7: Typical sound attenuation (in decibels) provided by buildings**

	Windows opened	Windows closed
<b>Warm climate</b>	12	24
<b>Cold climate</b>	17	24

Source: EPA, 1978.

**Table 8: Predicted foul-weather audible noise (AN) levels at edge of right-of-way (ROW) for proposed Santiam - Bethel/Santiam - Chemawa 230-kV line.** AN levels expressed in decibels on the A-weighted scale (dBA). L<sub>50</sub> and L<sub>5</sub> denote the levels exceeded 50 and 5 percent of the time, respectively. For the parallel-line configurations<sup>1</sup>, the AN level at the edge of the proposed Santiam - Bethel ROW is given first.

Configuration <sup>1</sup>	Foul-weather AN					
	Proposed			Existing		
	ROW ft. (m)	L <sub>50</sub> , dBA	L <sub>5</sub> , dBA	ROW ft. (m)	L <sub>50</sub> , dBA	L <sub>5</sub> , dBA
I	125 (38)	39	43	125 (38)	41	44
II	270 (82)	47, 52	51, 55	270 (82)	47, 52	51, 55

1 Configurations are described in Tables 1 and 2.

**Table 9: Predicted fair-weather radio interference (RI) levels at 100 feet (30.5 m) from the outside conductor of the proposed Santiam - Bethel/Santiam - Chemawa 230-kV line.** RI levels given in decibels above 1 microvolt/meter (dBμV/m) at 1.0 MHz. L<sub>50</sub> denotes level exceeded 50 percent of the time. For the parallel-line configurations the RI level on the side of the proposed Santiam - Bethel ROW is given first.

Configuration <sup>1</sup>	Fair-weather RI	
	Proposed	Existing
	L <sub>50</sub> , dBμV/m	L <sub>50</sub> , dBμV/m
I	26	28
II	30, 41	30, 41

1 Configurations are described in Tables 1 and 2.

**Table 10: Predicted maximum foul-weather television interference (TVI) levels predicted at 100 feet (30.5 m) from the outside conductor of the proposed Santiam - Bethel/Santiam - Chemawa 230-kV line.** TVI levels given in decibels above 1 microvolt/meter (dB $\mu$ V/m) at 75 MHz. For the parallel-line configurations, the TVI level on the side of the proposed Santiam - Bethel ROW is given first.

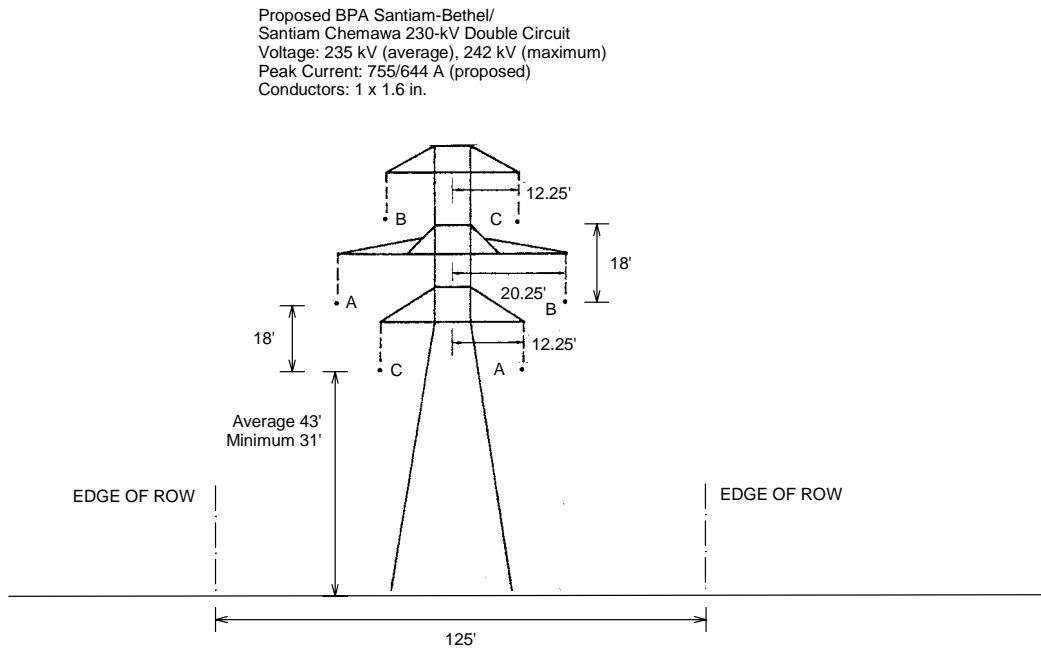
<b>Configuration<sup>1</sup></b>	<b>Foul-weather TVI</b>	
	<b>Proposed</b>	<b>Existing</b>
	<b>L<sub>5</sub> (foul), dB<math>\mu</math>V/m</b>	<b>L<sub>5</sub> (foul), dB<math>\mu</math>V/m</b>
<b>I</b>	10	15
<b>II</b>	12, 27	15, 27

1 Configurations are described in detail in Tables 1 and 2.

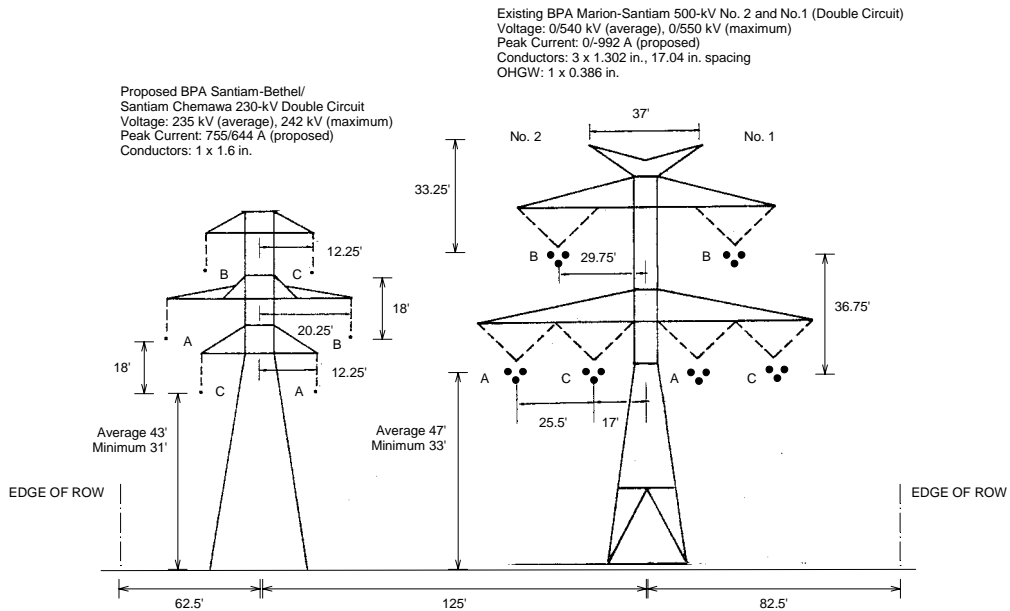


**Figure 1: Configurations for proposed Santiam - Bethel/Santiam - Chemawa 230-kV line: a) proposed line with no parallel lines ( Configuration I); and b) proposed line with parallel 500-kV line (Configuration II).**

a) Proposed line with no parallel lines (Configuration I) (not to scale)

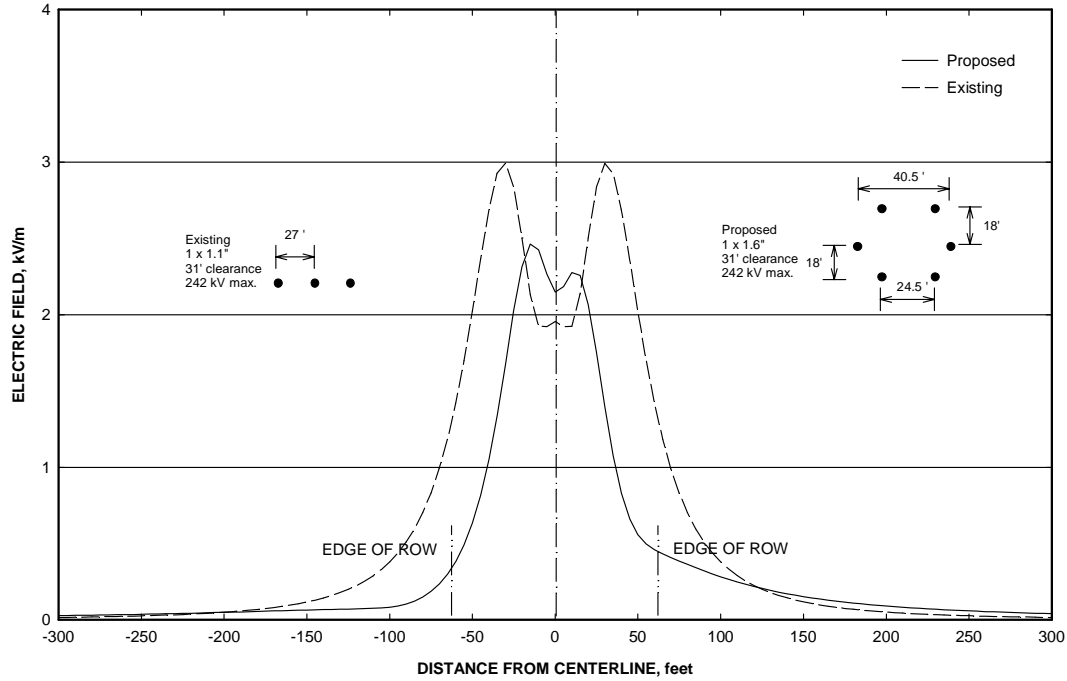


b) Proposed line with parallel 500-kV line (Configuration II) (not to scale)

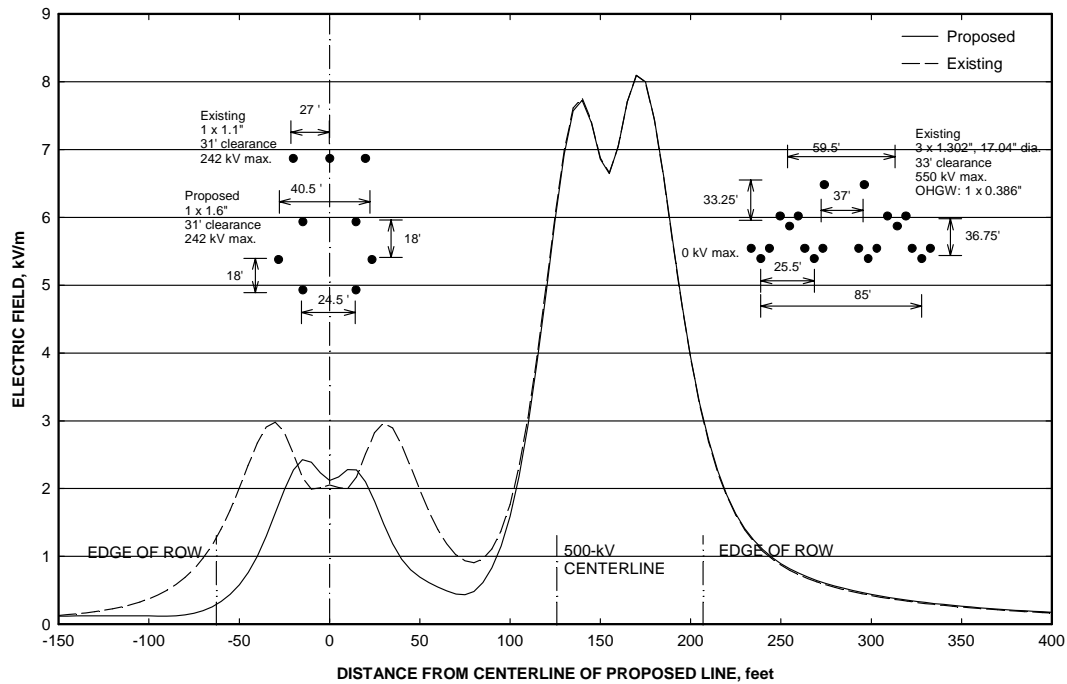


**Figure 2: Electric-field profiles for configurations of proposed Santiam - Bethel/Santiam - Chemawa 230-kV line: a) proposed line with no parallel line (Configuration I); and b) proposed line with parallel 500-kV line (Configuration II). Fields for maximum voltage and minimum clearances are shown.**

a) Proposed line with no parallel line (Configuration I).

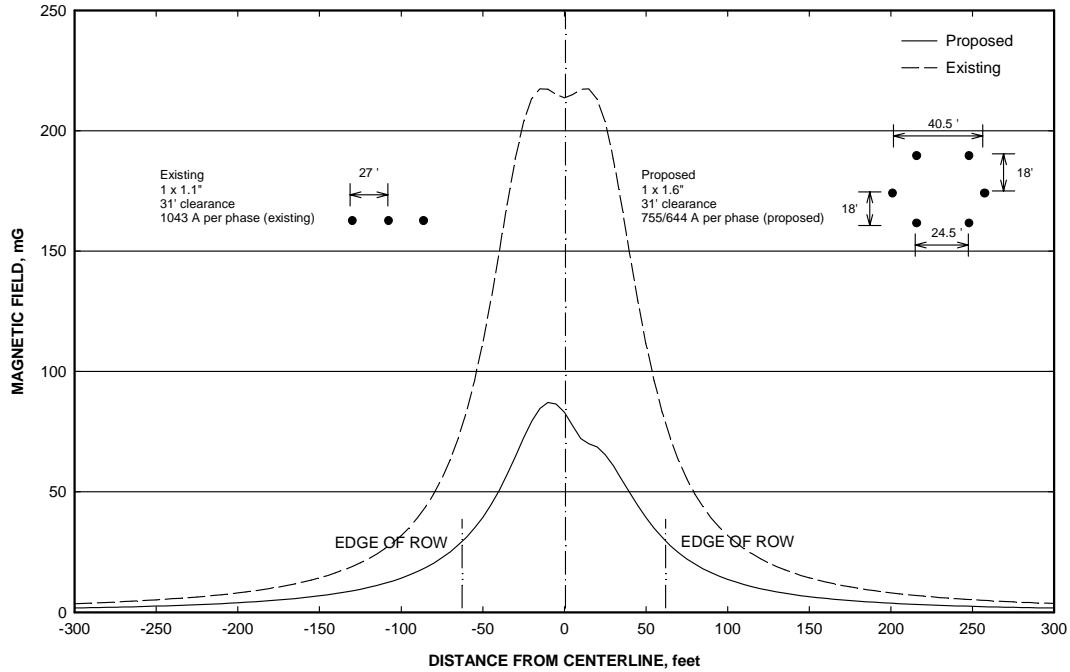


b) Proposed line with parallel 500-kV line (Configuration II)

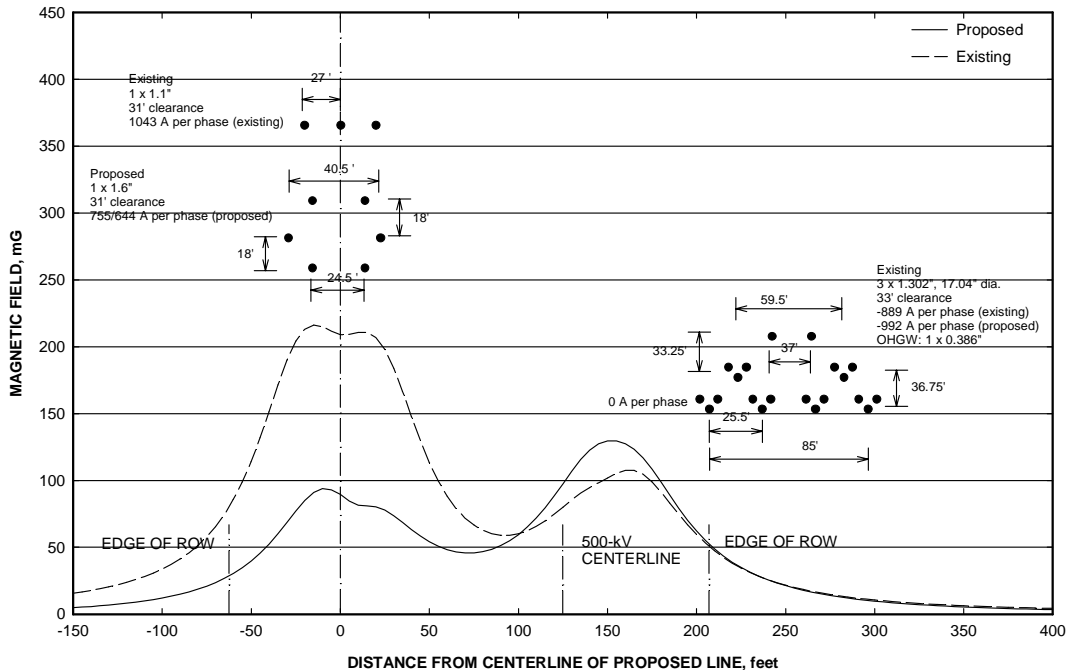


**Figure 3: Magnetic-field profiles for configurations of the proposed Santiam - Bethel/Santiam - Chemawa 230-kV line for maximum current conditions: a) proposed line with no parallel line (Configuration I); and b) proposed line with parallel 500-kV line (Configuration II).**

a) Proposed line with no parallel line (Configuration I)



b) Proposed line with parallel 500-kV line (Configuration II).



**SANTIAM-BETHEL TRANSMISSION PROJECT**

**APPENDIX B:**

**ASSESSMENT OF RESEARCH REGARDING EMF AND  
HEALTH AND ENVIRONMENTAL EFFECTS**

June 2001

Prepared by

**Exponent™**

and

**T. Dan Bracken, Inc.**

for

**Bonneville Power Administration**



## **Table of Contents**

1.0	Introduction .....	1
2.0	Health .....	1
2.1	The NIEHS Report and Research Program.....	1
2.2	Update of Research Related to Cancer.....	2
2.2.1	Epidemiology Studies of Children .....	2
2.2.2	Epidemiology Studies of Adults .....	5
2.2.3	Laboratory Studies of EMF.....	6
2.2.4	Summary Regarding Cancer .....	7
2.3	Research Related to Reproduction .....	7
2.4	Other Recent Reviews by Scientific Advisory Groups .....	7
2.4.1	National Radiological Protection Board of Great Britain (NRPB) Advisory Group on Non-Ionising Radiation .....	8
2.4.2	Health Council of the Netherlands.....	8
2.4.3	Institution of Electrical Engineers (IEE) of Great Britain.....	9
3.0	Ecological Research.....	9
3.1	Fauna.....	9
3.2	Flora .....	11
3.3	Summary .....	11
	LIST OF REFERENCES .....	12
	LIST OF PREPARERS .....	17



# **APPENDIX B: ASSESSMENT OF RESEARCH REGARDING EMF AND HEALTH AND ENVIRONMENTAL EFFECTS**

## **1.0 Introduction**

Over the last 20 years, research has been conducted in the United States (U.S.) and around the world to examine whether exposures to electric and magnetic fields (EMF) at 50/60 hertz (Hz) from electric power lines are a cause of cancer, or adversely affect human health. The research included epidemiology studies that suggested a link with childhood for some types of exposures, as well as other epidemiology studies that did not; it also included lifetime animal studies, which showed no evidence of adverse health effects. Comprehensive reviews of the research conducted by governmental and scientific agencies in the U.S. and in the United Kingdom (UK) had examined the research, and did not find a basis for imposing additional restrictions (NIEHS, 1999; IEE, 2000).

The Bonneville Power Administration (BPA) requested that Exponent update the BPA on research on EMF and health and in relation to exposures that might occur near the Bethel-Santiam Transmission Project.

This update concentrates on recent major research studies to explain how they contribute to the assessment of effects of EMF on health (Section 2). The focus is on both epidemiologic and laboratory research, because these research approaches provide different and complementary information for determining whether an environmental exposure can affect human health. Section 3, Ecological Research, reviews studies of potential effects of EMF on plants and animals in the natural environment. No additional studies of environmental effects were found in our search of the scientific literature through May 2001.

## **2.0 Health**

### **2.1 The NIEHS Report and Research Program**

In 1998, the NIEHS completed a comprehensive review of the scientific research on health effects of EMF. The NIEHS had been managing a research program that Congress funded in 1996, in response to questions regarding exposure to EMF from power sources. The program was known as the RAPID Program (Research and Public Information Dissemination Program). The NIEHS convened a panel of scientists (the “Working Group”) to review and evaluate the RAPID Program research and other research. Their report, *Assessment of Health Effects from Exposure to Power-Line Frequency Electric and Magnetic Fields*, was completed in July 1998 (NIEHS, 1998).

The director of the NIEHS prepared a health risk assessment of EMF and submitted his report to Congress in June 1999 (NIEHS, 1999). Experts at NIEHS, who had considered the previous Working Group report, reports from four technical workshops, and research that became available after June 1998, concluded as follows:

The scientific evidence suggesting that ELF-EMF [extremely low frequency-electric and magnetic field] exposures pose any health risk is weak. The strongest evidence for health



effects comes from associations observed in human populations with two forms of cancer: childhood leukemia and chronic lymphocytic leukemia in occupationally exposed adults. . . . In contrast, the mechanistic studies and animal toxicology literature fail to demonstrate any consistent pattern . . . . No indication of increased leukemias in experimental animals has been observed. . . . The lack of consistent, positive findings in animal or mechanistic studies weakens the belief that this association is actually due to ELF-EMF, but it cannot completely discount the epidemiology findings. . . . The NIEHS does not believe that other cancers or other non-cancer health outcomes provide sufficient evidence of a risk to currently warrant concern (pp. 9-10).

Although the results of the RAPID research are described in some detail in the 1998 report, many of the studies had not been published in the peer-reviewed literature. Recognizing the need to have these results reviewed and considered for publication, the NIEHS arranged for a special edition of the journal *Radiation Research* (*Radiation Research*, 153(5), 2000) to be devoted to this topic.<sup>1</sup>

## **2.2 Update of Research Related to Cancer**

This update includes studies of residential or occupational exposures to EMF and leukemia that became available this year (2001), including several reports from the California Department of Health Services. That Department conducted a workshop in 1999 to discuss epidemiologic research on EMF and health. The reports presented at this workshop were published in January 2001 as a supplement to the journal, *Bioelectromagnetics*. Many of the papers were technical discussions of methodology issues in epidemiologic studies of EMF, including discussions of how better to understand the conflicting results reported in previous studies (Neutra and Del Pizzo, 2001). For example, one paper evaluated epidemiology studies to determine whether systematic errors occurred in selection of cases and controls, or measurement of exposure. Although such systematic errors, or bias, occurred in some studies, there was insufficient information to assess the effect on results (Wartenberg, 2001a). Other researchers discuss epidemiologic approaches to study how possible confounding factors, such as the age and type of home and traffic density, might affect the interpretation of studies of EMF and childhood cancer (Langholz, 2001; Reynolds et al., 2001).

For this update, we review papers from this workshop that provide new information or statistical analyses. Several of the studies are “meta-analyses,” an approach that incorporates statistical methods to analyze differences and aggregate the results of smaller studies. The section below includes a review of meta-analyses of the studies of childhood leukemia through 1999, and a meta-analysis of studies of breast cancer in adults (Erren, 2001).

### **2.2.1 Epidemiology Studies of Children**

The question of power lines and childhood cancer has been based on the assumption that the relevant exposure associated with power lines is the magnetic field, rather than the electric field. This assumption rests on the fact that electric fields are shielded from the interior of homes (where people spend the vast majority of their time) by walls and vegetation, while magnetic fields are not. The magnetic field in the vicinity of a power line results from the flow of current; higher currents result in higher levels of magnetic fields.

---

<sup>1</sup> See, for instance, the articles cited in the **List of References** under Balcer- Kubiczek, Boorman, Loberg, and Ryan.

Epidemiologic studies report results in the form of statistical associations. The term “statistical association” is used to describe the tendency of two things to be linked or to vary in the same way, such as level of exposure and occurrence of disease. However, statistical associations are not automatically an indication of cause and effect, because the interpretation of numerical information depends on the context, including (for example) the nature of what is being studied, the source of the data, how the data were collected, and the size of the study. The larger studies and more powerful studies of EMF have not reported convincing statistical associations between power lines and childhood leukemia (e.g., Linet et al., 1997; McBride et al., 1999; UKCCS, 1999). Despite the larger sample size, these studies usually had a limited number of cases exposed over 2 or 3 milligauss (mG).

### *Epidemiology studies*

The following discussion briefly describes major studies.

- A study from Germany included 502 children with leukemia and 1,289 control children (Schuz et al., 2001). Measurements of magnetic-field intensity (50 Hz) were taken for 24 hours in the child’s bedroom. The results were calculated for daytime or nighttime levels in the bedroom, rather than for the child’s overall 24-hour exposure. The authors report an association with leukemia for mean daytime magnetic-field exposures that might have been due to chance. They reported an association between mean nighttime magnetic-field levels and leukemia for the highest exposed group (4 mG or higher; 9 cases). The assessment of exposure by mean field levels in the bedroom did not link magnetic-field levels to any specific source. The authors note in their conclusions that “. . . fewer than one-third of all stronger magnetic fields were caused by high-voltage powerlines. . . .” (Schuz et al., 2001: 734).

Several aspects of the study detract from the validity of the results: the estimate included a broad margin of error because only a small number of cases was exposed at the higher levels, and many eligible cases and controls did not participate, which means that the responders may not represent the population and results could be biased. Another concern is that these magnetic field measurements were taken in 1997, long after the relevant exposure period for cases diagnosed in 1990-1994. Magnetic-field levels may have changed over time, as electricity usage changed.

- A study from British Columbia, Canada, included 462 children who had been diagnosed with leukemia and an equal number of children without leukemia for comparison (McBride et al., 1999). Magnetic-field exposure was assessed for each of the children in several ways: personal monitors were worn in a backpack for 48 hours, a monitor took measurements in the bedroom for 24 hours, the wiring outside the house was rated by potential exposure level (wire codes), and measurements were taken around the outside perimeter of the homes. (Wire codes are a method of estimating relative exposure intensity based on the configuration of the power lines.) Regardless of the method used to estimate magnetic-field exposure, the magnetic-field exposure of children who had leukemia was not greater than that of the children in the comparison group.
- A study conducted in Ontario, Canada reported on the magnetic-field exposure of a smaller group of children (Green et al., 1999a). No increased risk estimates were found with the average magnetic fields in the bedroom or the interior, or with any of the three methods of estimating exposure from wire-configuration codes. A still smaller group of 88 children with leukemia and their controls wore personal monitors to measure magnetic fields (Green et al., 1999b). Associations with magnetic fields were reported in some of the analyses, but most of the risk estimates had a broad margin of error, and major methodological problems in the study preclude any clear interpretation of the findings.

- The United Kingdom Childhood Cancer Study, the largest study to date, included a total of 1073 childhood leukemia cases (UKCCS, 1999). Exposure was assessed by spot measurements in the home (bedroom and family room) and school, and summarized by averaging these over time. No evidence was found to support the idea of an increased risk of leukemia from exposures to magnetic fields from power sources inside or outside of the home.
- The UKCCS investigators had obtained magnetic-field measurements on only a portion of the cases in their study (UKCCS, 1999). To obtain additional information, they used a method to assess exposure to magnetic fields without entering homes; they were thus able to analyze 50% more subjects (UKCCS, 2000). For all these children, they measured distances to power lines and substations. This information was used to calculate the magnetic field from these external field sources, based on power-line characteristics related to production of magnetic fields. The results of the second UKCCS study showed no evidence for an association with leukemia for magnetic fields calculated to be between 1 mG and 2 mG, 2 mG and 4 mG, or 4 mG or greater at the residence, in contrast to the weak association reported for measured fields of 4 mG or greater in the first report (UKCCS, 1999).

Researchers have proposed that the associations that are sometimes reported between childhood leukemia and power lines may be due to other factors that can confound the analysis. One example is heavy traffic, which may occur near power lines and can increase the levels of potentially carcinogenic chemicals in the area. Earlier studies had reported associations between traffic density and childhood cancer (Savitz et al., 1988). If power lines were more common in areas that had higher traffic density, then the increased air pollution might explain an association between power lines and childhood cancer. However, more recent studies seem to eliminate this possibility. In a study of 90 cases of childhood leukemia, Reynolds et al. (2001) found no evidence of an association with traffic density. In a larger study that included 986 cases of childhood leukemia, no association was found with high traffic-density exposure during pregnancy or childhood (Raaschou-Nielsen et al., 2001). In addition, no association with childhood leukemia or brain cancer was found for exposures to benzene or nitrogen dioxide. Associations were reported between Hodgkin's disease and exposure to each of these chemicals.

#### *Meta-analyses of studies of leukemia*

Recently, researchers reanalyzed the data from previous epidemiology studies of magnetic fields and childhood leukemia (Ahlbom et al., 2000; Greenland et al., 2000). The researchers pooled the data on individuals from each of the studies, creating a study with a larger number of subjects and therefore greater statistical power than any single study. A pooled analysis is preferable to other types of meta-analyses in which the results from several studies are combined from grouped data obtained from the published studies. These analyses focused on studies that assessed exposure to magnetic fields using 24-hour measurements or calculations based on the characteristics of the power lines and current load. Both Ahlbom et al. and Greenland et al. used exposure categories of <0.1 microtesla ( $\mu\text{T}$ ) (<1 mG) as a reference category. The statistical results of these analyses can be summarized as follows:

- The pooled analyses provided no indication that wire codes are more strongly associated with leukemia than measured fields.
- Pooling these data corroborates an absence of an association between childhood leukemia and magnetic fields for exposures below 0.3  $\mu\text{T}$  (3 mG).
- Pooling these data results in a statistical association with leukemia for exposures greater than 0.3 or 0.4  $\mu\text{T}$  (3-4 mG).

The authors are appropriately cautious in the interpretation of their analyses, and they clearly identify the limitations in their evaluation of the original studies. Magnetic fields above 0.3  $\mu$ T in residences are estimated to be rather rare, about 3% in the U.S. (Zaffanella, 1993). Limitations include sparse data (few cases) to adequately characterize a relationship between magnetic fields and leukemia, uncertainties related to pooling different magnetic-field measures without evidence that all of the measures are comparable, and incomplete and limited data on important confounders (other risk factors for disease that may distort the analysis) such as housing type and traffic density.

A meta-analysis of the data from epidemiologic studies of childhood leukemia studies was presented at the California Workshop and recently published (Wartenberg, 2001b). This meta-analysis did not have the advantage of obtaining and pooling the data on all of the individuals in the studies, unlike those published before it (Ahlbom et al., 2000; Greenland et al., 2000). Rather than individual data, Wartenberg (2001b) used an approach that extracted the published results, reported as grouped data from several published studies. He used 19 studies overall, after excluding 7 studies that had insufficient data on individuals or deficiencies in the exposure assessment data. He reported a weak association for a) “proximity to electrical facilities” based on wire codes or distance, and b) magnetic-field level over 2 mG, based on either calculations from wiring and loading characteristics (if available) or on spot magnetic-field measurements. The results show more cases than controls exposed to measured or calculated fields above 2 mG. The author concludes that the analysis supports an association, although the size of the effect is small to moderate, but also notes “limitations due to design, confounding, and other biases may suggest alternative interpretations” (Wartenberg, 2001b:S-100).

The results of this meta-analysis are not directly comparable to previous ones regarding fields of 3 or 4 mG because the analysis was not based on individual data. The comparison of grouped data used different exposure cut points for the analysis and different criteria for the comparison group. None of these three analyses (Ahlbom et al., 2000; Greenland et al., 2000; Wartenberg, 2001b) includes the results of the UK analysis of over 3000 cases based on calculated fields, which found no association between EMF and childhood cancer, regardless of the exposure level.

### **2.2.2 Epidemiology Studies of Adults**

Studies of adults with certain types of cancer, such as brain cancer, breast cancer, or leukemia, have reported associations with exposure to magnetic fields at residences, but results have not been consistent across studies. Contradictory results among studies argue against a conclusion that the association reflects a cause-and-effect relationship. In their assessments of risk, scientists give most weight to studies that include more people, obtain more detailed and individual exposure assessments, and/or include people who have higher exposures.

A study of 492 adult cases of brain cancer in California included measurements of magnetic fields taken in the home and at the front door, and considered the types of power-line wiring (Wrensch et al., 1999). The authors report no evidence of increased risk with higher exposures, no association with type of power line, and no link with levels measured at the front door.

A number of recent studies of breast cancer focused on electric blankets as a source of high exposure. Electric blankets are assumed to be one of the strongest sources of EMF exposure in the home. Three studies of electric blanket use found no evidence that long-term use increased the risk of breast cancer. Women who developed breast cancer reported no difference in total use of electric blankets, use in recent years, or use many years in the past:

- Gammon et al. (1998) reported that, even for those who kept the blanket on most of the time, no increase in risk was found for those who had longer duration of use (measured in months).

- A study of 608 breast cancer cases also found no evidence of increased use of electric blankets or other home appliances in cases compared to controls, and no indication of increasing risk with a longer time of use (Zheng et al., 2000).
- In a cohort of over 120,000 female nurses, data were obtained on known risk factors for breast cancer as well as electric-blanket use (Laden et al., 2000). For a large subset of this group, the questions about exposure were asked before the disease occurred, a step taken to eliminate bias in recalling exposure.

Erren (2001) reported the results of a meta-analysis of the studies of breast cancer, in which the results of 24 different studies in women were statistically aggregated. When the results of all 24 studies were pooled, including studies of workplace exposures, the estimate indicated an association between EMF and a small excess breast cancer risk. The pooled results for exposure to EMF in the vicinity of electrical facilities did not show an association with breast cancer, nor did the results for exposure to EMF from appliance use. However, the meta-analysis also showed a lack of consistency among the results of the individual studies, a broad variation in the designs, and a wide range of methods used to assess exposure. No adjustments were made to the data to give increased weight to studies based on more comprehensive exposure assessments. The author also noted that the weak statistical association might be an artifact (a result of chance or unforeseen error) rather than an indication of a cause-and-effect relationship (Erren, 2001).

### **2.2.3 Laboratory Studies of EMF**

Laboratory studies complement epidemiologic studies of people because the effects of heredity, diet, and other health-related exposures of animals can be better controlled or eliminated. The assessment of EMF and health, as for any other exposure, includes chronic, long-term studies in animals (*in vivo* studies) and studies of changes in genes or other cellular processes observed in isolated cells and tissues in the laboratory (*in vitro*).

Although the results of the RAPID Program were described in some detail in the NIEHS reports (NIEHS, 1998), many of the studies had not been published in the peer-reviewed literature. The RAPID research program included studies of four biological effects, each of which had been observed in only one laboratory. These effects are as follows: effects on gene expression, increased intracellular calcium in a human cell line, proliferation of cell colonies on agar, and increased activity of the enzyme ornithine decarboxylase (ODC). Some scientists have suggested that these biological responses are signs of possible adverse health effects of EMF. It is standard scientific procedure to attempt to replicate results in other laboratories, because artifacts and investigator error can occur in scientific investigations. Replications, often using more experiments or more rigorous protocols, help to ensure objectivity and validity. Attempts at replication can substantiate and strengthen an observation, or they may discover the underlying reason for the observed response.

Studies in the RAPID program reported no consistent biological effects of EMF exposure on gene expression, intracellular calcium concentration, growth of cell colonies on agar, or ODC activity (Boorman et al., 2000b). For example, Loberg et al. (2000) and Balcer-Kubiczek et al. (2000) studied the expression of hundreds of cancer-related genes in human mammary or leukemia cell lines. They found no increase in gene expression with increased intensity of magnetic fields. To test the experimental procedure, they used X-rays and treatments known to affect the genes. These are known as positive controls and, as expected, caused gene expression in exposed cells.

Scientists have concluded that the combined animal bioassay results provide no evidence that magnetic fields cause, enhance, or promote the development of leukemia and lymphoma, or mammary cancer (e.g., Boorman et al., 1999; McCormick et al., 1999; Boorman et al., 2000 a, b; Anderson et al., 2001).

#### **2.2.4 Summary Regarding Cancer**

Epidemiology studies do not support the idea that EMF from power lines increase the risk of cancers in adults. The latest epidemiologic studies of childhood cancer, considered in the context of the other data, provide no persuasive and consistent evidence that leukemia in children is causally associated with magnetic fields measured at the home, calculated based on distance and current loading, or with wire codes. Recent meta-analyses reported no association between childhood cancer and magnetic fields below 2 or 3 mG. Although some association was reported for fields above this level, fields at most residences are likely to be below 3 or 4 mG. The authors of each of these analyses list several biases and problems that render the data inconclusive, and prevent resolution of the inconsistencies in the epidemiologic data. For this reason, laboratory studies can provide important complementary information. Large, well-conducted animal studies provide no convincing evidence that exposure increases the risk of cancer. Animal studies, and studies of initiation and promotion, provide no basis to conclude that EMF increases leukemia, lymphoma, breast, brain, or any other type of cancer.

#### **2.3 Research Related to Reproduction**

Previous epidemiologic studies reported no association with birth weight or fetal growth retardation after exposure to sources of relatively strong magnetic fields, such as electric blankets, or sources of typically weaker magnetic fields such as power lines (Bracken et al., 1995; Belanger et al., 1998).

A recent epidemiology study examined miscarriages<sup>2</sup> in relation to exposures to magnetic fields from electric bed-heating (electric blankets, heated waterbeds and mattress pads), which result in higher exposures than residential fields in general (Lee et al., 2000). The researchers assessed exposure prior to the birth (a prospective study) and included information to control for potential confounding factors (other exposures and conditions that affect the risk of miscarriage). This study had a large number of cases and high participation rates. Miscarriage rates were lower among users of electric bed heating.

Studies of laboratory animals exposed to pure 60-Hz fields have shown no increase in birth defects, no multigenerational effects, and no changes that would indicate an increase in miscarriage or loss of fertility (e.g., Ryan et al., 1999; Ryan et al., 2000). Exposed and unexposed litters were no different in the amount of fetal loss and the number and type of birth defects, indicating no reproductive effect of EMF.

In summary, the recent evidence from epidemiology and laboratory studies provides no indication that exposure to power-frequency EMF has an adverse effect on reproduction, pregnancy, or growth and development of the embryo. The results of these recent studies are consistent with the conclusions of the NIEHS.

#### **2.4 Other Recent Reviews by Scientific Advisory Groups**

Reviews of the scientific research regarding EMF and health by Health Council of the Netherlands and the Institute of Electrical Engineers of the UK were published in 2000. The National Radiological

---

<sup>2</sup> The medical term for miscarriage is spontaneous abortion.

Protection Board of Great Britain (NRPB) Advisory Group on Non-Ionizing Radiation published the most recent review in 2001. This review includes research published in 2000, and includes the most comprehensive discussion of the individual research studies.

#### **2.4.1 National Radiological Protection Board of Great Britain (NRPB) Advisory Group on Non-Ionising Radiation**

The conclusions from the report prepared by the NRPB's Advisory Group on Non-Ionising Radiation (AGNIR) on extremely low frequency (ELF) EMF and the risk of cancer are consistent with previous reviews. Members from universities, medical schools, and cancer research institutes reviewed the reports of experimental and epidemiological studies, including reports in the literature in 2000. Their general conclusions are as follows:

Laboratory experiments have provided no good evidence that extremely low frequency electromagnetic fields are capable of producing cancer, nor do human epidemiological studies suggest that they cause cancer in general. There is, however, some epidemiological evidence that prolonged exposure to higher levels of power frequency magnetic fields is associated with a small risk of leukaemia in children. In practice, such levels of exposure are seldom encountered by the general public in the UK [or in the US] (NRPB, 2001: 164).

The group further recognizes that the scientific evidence suggesting that exposure to power-frequency electromagnetic fields poses an increased risk of cancer is very weak. Virtually all of the cellular, animal, and human laboratory evidence provides no support for an increased risk of cancer incidence following such exposure to power frequencies, although sporadic positive findings have been reported. In addition, the epidemiological evidence is, at best, weak.

These conclusions of the Advisory Group are consistent with previous reviews by the NIEHS (1999) and the Health Council of the Netherlands (HCN, 2000). The NRPB response to the Advisory Group report states "the review of experimental studies by [the Advisory Group] AGNIR gives no clear support for a causal relationship between exposure to ELF-EMFs and cancer" (NRPB, 2001:1).

#### **2.4.2 Health Council of the Netherlands**

The Health Council of the Netherlands has prepared an update of its 1992 Advisory Report on exposure to electromagnetic fields (0 Hz to 10 MHz) (HCN, 2000). Members of the Expert Committee prepared the report. The Expert Committee based its analysis on the review and summaries of the studies provided in the NIEHS (1998) and concurred with the views of the director of the NIEHS (1999). For the update, the Committee evaluated a number of publications that appeared after these reports, e.g., McBride et al. (1999) and Green et al. (1999a), and wrote:

The committee thinks that the quality of the relevant epidemiological research has improved considerably since the publication of the advisory report in 1992. Even so, this research has not resulted in unequivocal, scientifically reliable conclusions (p. 15).

The Council emphasizes that the associations with EMF reported in epidemiologic studies are strictly statistical and do not demonstrate a cause-and-effect relationship. In their view, experimental research does not demonstrate a causal link or a mechanism to explain EMF as a cause of disease in humans. They concluded that there is no reason to recommend measures to limit residence near overhead power lines (HCN, 2000).

### **2.4.3 Institution of Electrical Engineers (IEE) of Great Britain**

One of the recent reviews was that of the Institution of Electrical Engineers (IEE) of Great Britain (IEE, 2000). In 1992, the IEE set up a Working Party whose eight members, with broad expertise in the health sciences, review the relevant scientific literature and prepare reports of their views. Their conclusion is based on recent major epidemiologic studies and the scientific literature built up over the past 20 years. In May 2000, the Working Party concluded “. . . that there is still not convincing scientific evidence showing harmful effects of low level electromagnetic fields on humans” (IEE, 2000:1).

## **3.0 Ecological Research**

Scientists have studied the effects of high-voltage transmission lines on many plant and animal species in the natural environment. In this section, we briefly review the research on the effects of EMF on ecological systems to assess the likelihood of adverse impacts. In addition to the comprehensive review of research on this topic by wildlife biologists at the BPA (Lee et al., 1996), we searched the published scientific literature for more recent studies published between 1995 and May 2001.

### **3.1 Fauna**

The habitat on the transmission-line right-of-way and surrounding area shields most wildlife from electric fields. Vegetation in the form of grasses, shrubs, and small trees largely shields small ground-dwelling species such as mice, rabbits, foxes, and snakes from electric fields. Species that live underground, such as moles, woodchucks, and worms, are further shielded from electric fields by the soil. Hence, large species such as deer and domestic livestock (e.g., sheep and cattle) have greater potential exposures to electric fields since they can stand taller than surrounding vegetation. However, the duration of exposure for deer and other large animals is likely to be limited to foraging bouts or the time it takes them to cross under the line. Furthermore, all species would be exposed to higher magnetic fields under a transmission-line than elsewhere, as the vegetation and soil do not provide shielding from this aspect of the transmission-line electrical environment.

Field studies have been performed in which the behavior of large mammals in the vicinity of high-voltage transmission lines was monitored. No effects of electric or magnetic fields were evident in two studies from the northern United States on big game species, such as deer and elk, exposed to a 500-kV transmission line (Goodwin 1975; Picton et al., 1985). In such studies, a possible confounding factor is audible noise. Audible noise associated with high-voltage power transmission lines (with voltages greater than 110-kV) is due to corona. Audible noise generated by transmission lines reaches its highest levels in inclement weather (rain or snow).

Much larger populations of animals that might spend time near a transmission line are livestock that graze under or near transmission lines. To provide a more sensitive and reliable test for adverse effects than informal observation, scientists have studied animals continuously exposed to fields from the lines in relatively controlled conditions. For example, grazing animals such as cows and sheep have been exposed to high-voltage transmission lines and their reproductive performance examined (Lee et al., 1996). In some studies, the effects of exposure over one or more successive breedings were examined (Angell et al., 1990). Compared to unexposed animals in a similar environment, it was found that the exposure did not affect reproductive functions or pregnancy of cows (Algers and Hennichs, 1985; Algers and Hultgren, 1987).

A group of investigators from Oregon State University, Portland State University, and other academic centers evaluated the effects of long-term exposure to EMF from a 500-kV transmission line operated by



BPA on various cellular aspects of immune response, including the production of proteins by leukocytes (IL-1 and IL-2) of sheep. In previous unpublished reports, the researchers found differences in IL-1 activity between exposed and control groups. However, in their most recent replication, the authors found no evidence of differences in these measures of immune function. The sheep were exposed to 27 months of continuous exposure to EMF, a period of exposure much greater than the short, intermittent exposures of sheep grazing under transmission lines. Mean exposures of magnetic and electric fields were 3.5-3.8  $\mu$ T (35-38 mG) and 5.2-5.8 kV/m, respectively (Hefeneider et al., 2001).

Scientists from Illinois Institute of Technology (IIT) monitored the possible effects of electric and magnetic fields on fauna and flora in Michigan and Wisconsin from 1969 – 1997 to evaluate the effects of an above-ground, military-communications antenna operating at 76 Hz. The antenna produces EMF similar in physical characteristics to those produced by high-voltage transmission lines, but of much lower intensity. This study included embryonic development, fertility, postnatal growth, maturation, aerobic metabolism, and homing behavior, and showed no adverse impacts of ELF electric and magnetic fields on the animals (NRC, 1997).

The hormone melatonin, secreted at night by the pineal gland, plays a role in animals that are seasonal breeders. Studies in laboratory mice and rats have suggested that exposure to electric and/or magnetic fields might affect levels of the hormone melatonin, but results have not been consistent (Wilson et al., 1981; Holmberg, 1995; Kroeker et al., 1996; Vollrath et al., 1997; Huuskonen et al., 2001). However, when researchers examined sheep and cattle exposed to EMF from transmission lines exceeding 500-kV, they found no effect on the levels of the hormone melatonin in blood, weight gain, onset of puberty, or behavior in sheep and cattle (Stormshak et al., 1992; Lee et al., 1993; Lee et al., 1995; Thompson et al., 1995; Burchard et al., 1998).

Another part of the IIT study examined the effect of the antenna system fields on the growth, development, and homing behavior of birds. Studies of embryonic development (Beaver et al., 1993), fertility, postnatal growth, maturation, aerobic metabolism, and homing behavior showed no adverse impacts of ELF electric and magnetic fields on the animals (NRC, 1997). Fernie and colleagues studied the effects of continuous EMF exposure of raptors to an electric field of 10 kV/m in a controlled, laboratory setting. The exposure was designed to mimic exposure to a 765-kV transmission line. Continuous EMF exposure was found to reduce hatching success, yet increase egg size, fledging success, and embryonic development (Fernie et al., 2000). In a study of the effects on body mass and food intake of reproducing falcons, the authors found that EMF lengthened the photoperiod as a result of altered melatonin levels in the male species, yet concluded that “EMF effects on adult birds may only occur after continuous, extended exposure,” which is not likely to occur from resting on power lines (Fernie and Bird, 1999:620).

Several avian species are reported to use the earth’s magnetic field as one of the cues for navigation. It has been proposed that deposits of magnetite in specialized cells in the head are the mechanism by which the birds can detect variations in the inclination and intensity of a dc magnetic field (Kirschvink and Gould, 1981; Walcott et al., 1988). In early studies of transmission lines, it was reported that the migratory patterns of birds appeared to be altered near transmission lines (Southern, 1975; Larkin and Sutherland, 1977). However, these studies were of crude design, and Lee et al. (1996) concluded that, “During migration, birds must routinely fly over probably hundreds (or thousands) of electrical transmission and distribution lines. We are not aware of any evidence to suggest that such lines are disrupting migratory flights” (p. 4-59). No further studies on this topic were identified in the literature.

Bees, like birds, are able to detect the earth’s dc magnetic fields. They are known to use magnetite particles, which are contained in an abdominal organ, as a compass (Kirschvink and Gould, 1981). In the

laboratory, they are able to discriminate between a localized magnetic anomaly and a uniform background dc magnetic field (Walker et al., 1982; Kirschvink et al., 1992).

Greenberg et al. (1981) studied honeybee colonies placed near 765-kV transmission lines. They found that hives exposed to electric fields of 7 kV/m had decreased hive weight, abnormal amounts of propolis (a resinous material) at hive entrances, increased mortality and irritability, loss of the queen in some hives, and a decrease in the hive's overall survival compared to hives that were not exposed. Exposure to electric fields of 7-12 kV/m may induce a current or heat the interior of the hive; however, placing the hive farther from the line, shielding the hive, or using hives without metallic parts eliminates this problem. ITT studied the effects of EMF on bees exposed to the 76-Hz antenna system at lower intensities and concluded that these behavioral effects of "ELF-EMF impacts are absent or at most minimal" (NRC, 1997:102).

Reptiles and amphibians contribute to the overall functioning of the forest ecosystems. However, little research has been performed on the effects of EMF on reptiles and amphibians in their natural habitat.

### **3.2 Flora**

Numerous studies have been carried out to assess the effect of exposure of plants to transmission-line electric and magnetic fields. These studies have involved both forest species and agriculture crops. Researchers have found no adverse effects on plant responses, including seed germination, seedling emergence, seedling growth, leaf area per plant, flowering, seed production, germination of the seeds, longevity, and biomass production (Lee et al., 1996).

The only confirmed adverse effect of transmission lines on plants was reported for transmission lines with voltages above 1200-kV. For example, Douglas Fir trees planted within 15 m of the conductors were shorter than trees planted away from the line. Shorter trees are believed to result from corona-induced damage to the branch tips. Trees between 15 and 30 m away from the line suffered needle burns, but those 30 m and beyond were not affected (Rogers et al., 1984). These effects would not occur at the lower field intensities expected beyond the right-of-way of the proposed 500-kV transmission line.

### **3.3 Summary**

The habitat on the transmission-line rights-of-way and surrounding areas shield smaller animals from electric fields produced by high-voltage transmission lines; thus, vegetation easily shields small animals from electric fields. The greatest potential for larger animals to be exposed to EMF occurs when they are passing beneath the lines. Studies of animal reproductive performance, behavior, melatonin production, immune function, and navigation have found minimal or no effects of EMF. Past studies have found little effect of EMF on plants; no recent studies of plants growing near transmission lines have been performed. In summary, the literature published to date has shown little evidence of adverse effects of EMF from high-voltage transmission lines on wildlife and plants. At the field intensities associated with the proposed 230-kV transmission line, no adverse effects on wildlife or plants are expected.

## **LIST OF REFERENCES**

- Ahlbom, A.; Day, N.; Feychting, M.; Roman, E.; Skinner, J.; Dockerty, J.; Linet, M.; Michealis, J.; Olsen, J.H.; Tynes, T.; Verasalo, P.K. 2000. A pooled analysis of magnetic fields and childhood leukaemia. *British Journal of Cancer*, 83(5): 692-698.
- Algers, B.; and Hennichs, K. 1985. The effect of exposure to 400-kV transmission lines on the fertility of cows: a retrospective cohort study. *Preventive Veterinary Medicine* 3: 351-361.
- Algers, B.; and Hultgren, J. 1987. Effects of long-term exposure to a 400-kV, 50-Hz transmission line on estrous and fertility in cows. *Preventive Veterinary Medicine* 5: 21-36.
- Anderson, L.E.; Morris, J.E.; Miller, D.L.; Rafferty, C.N.; Ebi, K.L.; Sasser, L.B. 2001. Large granular lymphocytic (LGL) leukemia in rats exposed to intermittent 60 Hz magnetic fields. *Bioelectromagnetics*, 22:185-193.
- Angell, R.F.; Schott, M.R.; Raleigh, R.J.; Bracken, T.D. 1990. Effects of a high-voltage direct-current transmission line on beef cattle production. *Bioelectromagnetics*. 11(4):273-82.
- Balcer-Kubiczek, E.K.; Harrison, G.H.; Davis, C.C.; Haas, M.L.; Koffman, B.H. 2000. Expression analysis of human HL60 exposed to 60 Hz square or sine-wave magnetic fields. *Radiation Research*, 153(5): 670-678.
- Beaver, D.L.; Hill, R.W.; Lederle, P.E. 1993. Assessment of the effects of extremely low frequency electromagnetic radiation on growth and maturation in nestling tree swallows and deer mice. *Electricity and Magnetism in Biology and Medicine*. M. Blank, ed., San Francisco Press, Inc., pp. 925-926.
- Belanger, K.; Leaderer, B.; Hellenbrand, K.; Holford, T.R.; McSharry, J.; Power, M.E.; Bracken, M.B. 1998. Spontaneous abortion and exposure to electric blankets and heated water beds. *Epidemiology*, 9:36-42.
- Boorman, G.A.; Anderson, L.E.; Morris, J.E.; Sasser, L.B.; Mann, P.C.; Grumbein, S.L.; Hailey, J.R.; McNally, A.; Sills, R.C.; Haseman, J.K. 1999. Effects of 26-week magnetic field exposure in a DMBA initiation-promotion mammary glands model in Sprague-Dawley rats. *Carcinogenesis*, 20: 899-904.
- Boorman, G.A.; McCormick, D.J.; Ward, J.M.; Haseman, J.K.; Sills, R.C. 2000a. Magnetic fields and mammary cancer in rodents: A critical review and evaluation of published literature. *Radiation Research*, 153(5), Part 2: 617.
- Boorman, G.A.; Rafferty, C.N.; Ward, J.M.; Sills, R.C. 2000b. Leukemia and lymphoma incidence in rodents exposed to low-frequency magnetic fields. *Radiation Research*, 153(5), Part 2: 627.
- Bracken, M.B.; Belanger, K.; Hellenbrand, K.; Dlugosz, L.; Holford, T.R.; McSharry, J.E.; Adesso, K.; Leaderer, B. 1995. Exposure to electromagnetic fields during pregnancy with emphasis on electrically heated beds: association with birth weight and intrauterine growth retardation. *Epidemiology*, 6(3): 263-270.

- Burchard, J.F.; Nguyen, D.H.; Block, E. 1998. Effects of electric and magnetic fields on nocturnal melatonin concentrations in dairy cows. *J Dairy Sci.* 81(3):722-7.
- Erren, T.C. 2001. A meta-analysis of epidemiological studies of electric magnetic fields and breast cancer in women and men. *Bioelectromagnetics Supplement*, 5: S105-S119.
- Fernie, K.J.; and Bird, D.M. 1999. Effects of electromagnetic fields on body mass and food-intake of American kestrels. *The Condor.* 101:616-621.
- Fernie, K.J.; Bird, D.M.; Dawson, R.D.; Lague, P.C. 2000. Effects of electromagnetic fields on the reproductive success of American kestrels. *Physiol Biochem Zool.* 73(1):60-5.
- Gammon, M.D.; Schoenberg, J.B.; Britton, J.A.; Kelsey, J.L.; Stanford, J.L.; Malone, K.E.; Coates, R.J.; Brogan, D.J.; Potischman, N.; Swanson, C.A.; Brinton, L.A. 1998. Electric blanket use and breast cancer risk among younger women. *American Journal of Epidemiology*, 148: 556-63.
- Goodwin Jr., J.G. 1975. Big game movement near a 500-kV transmission line in northern Idaho. Bonneville Power Administration, Engineering and Construction Division, Portland, OR, June 27.
- Green, L.M.; Miller, A.B.; Villeneuve, P.J.; Agnew, D.A.; Greenberg, M.L.; Li, J.H.; Donnelly, K.E. 1999a. A case control study of childhood leukemia in southern Ontario, Canada, and exposure to magnetic fields in residences. *International Journal of Cancer*, 82:161-170.
- Green, L.M.; Miller, A.B.; Agnew, D.A.; Greenberg, M.L.; Li, J.H.; Villeneuve, P.J.; Tibshirani, R. 1999b. Childhood leukemia and personal monitoring of residential exposures to electric and magnetic fields in Ontario, Canada. *Cancer Causes and Control*, 10: 233-243.
- Greenberg, B.; Bindokas, V.P.; Frazier, M.J.; Gauger, J.R. 1981. Response of honey bees, *apis mellifera* L., to high-voltage transmission lines. *Environmental Entomology*, 10: 600-610.
- Greenland, S.; Sheppard, A.; Kelsh, M.; Kuane, W.; Poole, C.; Kelsh, M.A. 2000. Childhood leukemia and power frequency magnetic fields: analysis from pooled data of thirteen epidemiologic studies. *Epidemiology*, 11: 624-634.
- HCN (Health Council of the Netherlands). 2000. Report on Exposure to Electromagnetic Fields (0 Hz – 10 MHz). No. 2000/06E.
- Hefeneider, S.H.; McCoy, S.L.; Hausman, F.A.; Christensen, H.L.; Takahashi, D.; Perrin, N.; Bracken, T.D.; Shin, K.Y.; Hall, A.S. 2001. Long-term effects of 60-Hz electric vs. magnetic fields on IL-1 and IL-2 activity in sheep. *Bioelectromagnetics*, 22(3):170-177.
- Holmberg, B. 1995. Magnetic fields and cancer: animal and cellular evidence—an overview. *Environ Health Perspect.* 103 Suppl 2:63-7.
- Huuskonen, H.; Saastamoinen, V.; Komulainen, H.; Laitinen, J.; Juutilainen, J. 2001. Effects of low-frequency magnetic fields on implantation in rats. *Reprod Toxicol*, 15(1):49-59.
- IEE (Institution of Electrical Engineers), Biological Effects Working Party. May 2000. The possible harmful biological effects of low level electromagnetic fields of frequencies up to 300 GHz. IEE Position Statement.

- Kirschvink, J.L.; and Gould, J.L. 1981. Biogenic magnetite as a basis for magnetic field detection in animals. *Biosystems*, 13(3):181-201.
- Kirschvink, J.L.; Diaz Ricci, J.; Nesson, M.H.; Kirschvink, S.J. 1992. Magnetite-based magnetoreceptors in animals: structural, behavioral, and biophysical studies. Electric Power Research Institute (EPRI), Report No. TR-102008, Palo Alto, CA. September.
- Kroeker, G.; Parkinson, D.; Vriend, J.; Peeling, J. 1996. Neurochemical effects of static magnetic field exposure. *Surg Neurol*, 45(1):62-6.
- Laden, F.; Neas, L.M.; Tolbert, P.E.; Holmes, M.D.; Hankinson, S.E.; Spiegelman, D.; Speizer, F.E.; Hunter, D.J. 2000. Electric blanket use and breast cancer in the nurses' health study. *American Journal of Epidemiology*, 152(1): 41-49.
- Langholz, B. 2001. Factors that explain the power line configuration wiring code - childhood leukemia association: what would they look like? *Bioelectromagnetics Supplements*, 5: S19-S31.
- Larkin, R.P., and Sutherland, P.J. 1977. Migrating birds respond to Project Seafarer's electromagnetic field. *Science*, 195(4280): 777-9 1977, Feb 25.
- Lee, G.M.; Neutra, R.R.; Hristova, L.; Yost, M.; Hiatt, R.A. 2000. The use of electric bed heaters and the risk of clinically recognized spontaneous abortion. *Epidemiology*, 11: 406-415.
- Lee, J., Stormshak, F., Thompson, J., Thinesen, P., Painter, L., Olenchek, B., Hess, D., Forbes, R. 1993. Melatonin secretion and puberty in female lambs exposed to environmental electric and magnetic fields. *Biol Reprod* 49(4):857-64
- Lee, J.M. BPA Biological Studies Task Team. 1996. Electrical and biological effects of transmission lines: a review. Bonneville Power Administration, Portland, Oregon, December.
- Lee, J.M., Stormshak, F., Thompson, J., Hess, D.L., Foster, D.L. 1995. Melatonin and puberty in female lambs exposed to EMF: a replicate study. *Bioelectromagnetics*, 16(2):119-23
- Linnet, M.S.; Hatch E.H.; Kleinerman, R.A.; Robinson, L.L.; Kaune, W.T.; Friedman, D.R.; Seversch, R.K.; Haines, C.M.; Hartsock, C.T.; Niwa, S.; Wacholder, S.; Tarone, R.E. 1997. Residential exposure to magnetic fields and acute lymphoblastic leukemia in children. *New England Journal of Medicine*, 337: 1-7.
- Loberg, L.I.; Engdahl, W.R.; Gauger, J.R.; McCormick, D.L. 2000. Expression of cancer-related genes in human cells exposed to 60 Hz magnetic fields. *Radiation Research*, 153(5): 679-684.
- McBride, M.L.; and Gallagher, RP; Theriault, G; Armstrong, BG; Tamaro, S; Spinelli, JJ; Deadman, JE; Fincham, S; Robinson, D; Choi, W. 1999. Power-frequency electric and magnetic fields and risk of childhood leukemia in Canada. *American Journal of Epidemiology*, 149:831-842.
- McCormick, D.L.; Boorman, G.A.; Findlay, J.C.; Hailey, J.R.; Johnson, T.R.; Gauger, J.R.; Pletcher, J.M.; Sill, R.C.; Haseman, J.K. 1999. Chronic toxicity/oncogenicity evaluation of 60 Hz (power frequency) magnetic fields in B6C3F mice. *Toxicologic Pathology*, 27:279-285.

- Neutra, R.R., and Del Pizzo, V. 2001. A richer conceptualization of "exposure" for epidemiological studies of the "EMF mixture". *Bioelectromagnetics Supplements*, 5: S48-S57.
- NIEHS (National Institute of Environmental Health Sciences). 1998. Assessment of Health Effects from Exposure to Power-Line Frequency Electric and Magnetic Fields: Working Group Report. NIH Publication No. 98-3981. Research Triangle Park, NC: National Institute of Environmental Health Sciences of the U.S. National Institutes of Health.
- NIEHS (National Institute of Environmental Health). 1999. Health effects from exposure to power line frequency electric and magnetic fields. NIH; National Institute of Health; NIH No. 99-4493; Research Triangle Park, NC.
- NRC (National Research Council). 1997. An evaluation of the U.S. Navy's extremely low frequency communications system ecological monitoring program. National Academy Press, Washington, D.C.
- NRPB (National Radiological Protection Board). 2001. Response statement of the NRPB: ELF electromagnetic fields and the risk of cancer. National Radiological Protection Board, Chilton, Didcot, Oxon, Volume 12, No.1, ISBN 0-859951-456-0.
- Picton, H.D., Canfield, J.E., Nelson, G.P. 1985. The impact of a 500-kV transmission line upon the North Boulder Winter Elk Range. US Forest Service Contract 53-0398-30E-3.
- Raaschou-Nielsen, O.; Hertel, O.; Thomsen, B.L.; Olsen, J.H. 2001. Air pollution from traffic at the residence of children with cancer. *American Journal of Epidemiology*, 153(5): 433-43.
- Radiation Research*. 2000. (Special Edition Updating RAPID results.) 153(5): 637-641. *See entries under Balcer-Kubiczek, Boorman, Loberg, and Ryan.*
- Reynolds, P.; Elkin, E.; Scalf, R.; Von Behren, J.; Neutra, R.R. 2001. A case-control pilot study of traffic exposures and early childhood leukemia using a geographic information system. *Bioelectromagnetics Supplements*, 5:S58-S6.
- Rogers, L.E., Beedlow, P.A., Carlile, D.W., Ganok, K.A., Lee, J.M. 1984. Environmental studies of a 1100-kV prototype transmission line: an annual report for the 1984 study period. Prepared by Battelle Pacific Northwest Laboratories for Bonneville Power Administration, Portland, Oregon.
- Ryan, B.M.; Symanski, R.R.; Pomeranz, L.E.; Johnson, T.R.; Gauger, J.R.; McCormick, D.L. 1999. Multi-generation reproduction toxicity assessment of 60-Hz magnetic fields using a continuous breeding protocol in rats. *Teratology*, 59(3): 156-62.
- Ryan, B.M.; Polen, M.; Gauger, J.R.; Mallett, E.; Kerns, M.B.; Bryan, T.L.; McCormick, D.L. 2000. Evaluation of the developmental toxicity in Sprague-Dawley rats. *Radiation Research*, 153(5): 637-641.
- Savitz, D.A., Wachtel, H., Barnes, F.A., John, E.M. & Tvrdik, J.G. 1988. Case-control study of childhood cancer and exposure to 60 Hz magnetic fields. *American Journal of Epidemiology*, 128, 21-38.
- Schuz, J.; Grigat, J.P.; Brinkmann, K.; Michaelis, J. 2001. Residential magnetic fields as a risk factor for childhood acute leukaemia: results from a German population-based case-control study. *International Journal of Cancer*, 91(5): 728-735. January 2.

- Southern, W.E. 1975. Orientation of gull chicks exposed to project Sanguine's electromagnetic field. *Science*, 189: 143-144.
- Stormshak, F., Bracken, T.D., Carey, M., Chartier, V., Dickson, L., Forbes, R., Hall, A., Havens, P., Hess, D., Krippaehne, S., Lee, J., Ogden, B., Olenchek, B., Painter, L., Rowe, K., Stearns, R., Thinesen, P., Thompson, J. 1992. Joint HVAC transmission EMF environmental study: final report on experiment 1. Bonneville Power Administration, Contract # DE-B179-90BPO4293, Portland, OR, May.
- Thompson, J.M.; Stormshak, F.; Lee, J.M.; Hess, D.; Painter, L. 1995. Cortisol secretion and growth in ewe lambs chronically exposed to electric and magnetic fields of a 60-Hertz 500-kilovolt AC transmission line. *J Animal Sci*, 73(11):3274-80
- UKCCS (United Kingdom Childhood Cancer Study Investigators). 1999. Exposure to power frequency magnetic fields and the risk of childhood cancer. *The Lancet*, 353(9194): 1925-31.
- UKCCS (United Kingdom Childhood Cancer Study Investigators). 2000. Childhood cancer and residential proximity to power lines. *British Journal of Cancer*, 83:1573-80.
- Vollrath, L.; Spessert, R.; Kratzsch, T.; Keiner, M.; Hollmann H. 1997. No short-term effects of high-frequency electromagnetic fields on the mammalian pineal gland. *Bioelectromagnetics*, 18(5):376-87.
- Walcott, C.; Gould, J.L.; Lednor, A.J. 1988. Homing of magnetized and demagnetized pigeons. *J Exp Biol*, 134:27-41.
- Walker, C.E.; Seitelman, D.L.; McElhaney, J.H.; Mullen, S.P.; Hagadorn, B.; Seto, Y.J. 1982. Effects of high-intensity 60-Hz fields on bone growth. *Journal of Bioelectricity*, 1(3):339-349.
- Wartenberg, D. 2001a. The potential impact of bias in studies of residential exposure to magnetic fields and childhood leukemia. *Bioelectromagnetics Supplements*, 5: S32-S47.
- Wartenberg, D. 2001b. Residential EMF exposure and childhood leukemia: Meta-analysis and population attributable risk. *Bioelectromagnetics Supplements*, 5: S86-S104.
- Wilson, B.W.; Anderson, L.E.; Hilton, D.I.; Phillips, RD. 1981. Chronic exposure to 60-Hz electric fields: effects on pineal function in the rat. *Bioelectromagnetics*, 2(4):371-80.
- Wrensch, M.; Yost, M.; Miike, R.; Lee, G.; Touchstone, J. 1999. Adult glioma in relation to residential power frequency electromagnetic field exposures in the San Francisco Bay Area. *Epidemiology*, 10: 523-527.
- Zaffanella, L.E. 1993. Survey of residential magnetic field sources. Vol. 1: Goals, results, and conclusions. (EPRI TR-102759-V1, Project 3335-02). Electric Power Research Institute, Palo Alto, CA.
- Zheng, T.Z.; Holford, T.R.; Mayne, S.T.; Owens, P.H.; Zhang, B.; Boyle, P.; Carter, D.; Ward, Y.W.; Zahm, S.H. 2000. Exposure to electromagnetic fields from use of electric blankets and other in-home electrical appliances and breast cancer risk. *American Journal of Epidemiology*, 151(11): 1103-11.

## LIST OF PREPARERS

**Linda S. Erdreich, Ph.D.**, is a Managing Scientist in the Health Group at Exponent. She received her Ph.D. in Epidemiology and an M.S. in Biostatistics and Epidemiology from The University of Oklahoma Health Sciences Center. Dr. Erdreich is an epidemiologist with specific expertise in biological and health research related to non-ionizing radiation, both radiofrequency and power-frequency fields. Formerly, she was Acting Section Chief and Group Leader of the Methods Evaluation and Development Staff at the U.S. Environmental Protection Agency (EPA) and Senior Epidemiologist of the Environmental Criteria and Assessment Office at the EPA. While at the EPA, she developed methods in quantitative health risk assessment, coordinated the drafting of federal guidelines, and participated in science policy decisions. Both in government and private industry, she has provided rigorous evaluations of the impact on public health or occupational health of a variety of chemicals, therapeutic drugs, and physical agents, including electric and magnetic fields. As a member of the Institute of Electrical and Electronics Engineers (IEEE) Standards Coordinating Committees on Non-Ionizing Radiation, Dr. Erdreich is chairman of a working group to evaluate epidemiologic data on radiofrequency exposures (3 kHz–300 GHz). She has been appointed as a member of the Committee on Man and Radiation (COMAR) of the IEEE's *Engineering in Biology and Medicine Society*. Dr. Erdreich serves as Adjunct Associate Professor at the University of Medicine & Dentistry of New Jersey.

**William H. Bailey, Ph.D.**, is a Principal Scientist and manages the Health Group scientists in Exponent's New York office. Before joining Exponent, Dr. Bailey was President of Bailey Research Associates, Inc., the oldest research and consulting firm with specialized expertise in electro-magnetic fields and health. Dr. Bailey specializes in applying state-of-the-art assessment methods to environmental health and impact issues. His 30 years of training and experience include laboratory and epidemiologic research, health risk assessment, and comprehensive exposure analysis. Dr. Bailey is particularly well known for his research on potential health effects of electromagnetic fields and is active in setting IEEE standards for human exposure to electromagnetic fields. He uses advanced analytical and statistical methods in the design and analysis of both experimental studies and epidemiology and survey research studies. In addition, Dr. Bailey's postgraduate training in the social, economic, and behavioral sciences is helpful in assessing the important effects of social, economic, and community factors on health risks and vulnerability to environmental impacts in health and environmental justice research. He is a member of a working group that advises a committee of the World Health Organization on risk assessment, perception, and communication. Dr. Bailey is also a visiting scientist at the Cornell University Medical College. He was formerly Head of the Laboratory of Neuropharmacology and Environmental Toxicology at the New York State Institute for Basic Research, Staten Island, New York, and an Assistant Professor and NIH postdoctoral fellow in Neurochemistry at The Rockefeller University in New York.

**Maria DeJoseph, M.S.**, is an Epidemiologist in Exponent's Health Group and is based in New York, New York. Ms. DeJoseph has a background in epidemiology and biological sciences. She served as the primary investigator for a case-control epidemiologic study of her design to investigate a mediastinitis outbreak in cardiothoracic surgery patients. Ms. De Joseph also has recruited and interviewed subjects, and analyzed hormone levels for an epidemiologic breast cancer study. She has conducted phytochemical analyses of medicinal plants, including the isolation and fractionation of tropical plants used medicinally by indigenous peoples and primates of Central and South America. Ms. DeJoseph has served as an ethnobotanical and zoopharmacological field researcher in Mexico, Costa Rica and Venezuela. She has used a variety of methods to identify chemical and prospective pharmaceutical compounds, including HPLC, column chromatography, anti-microbial assays, gas chromatography mass spectrometry (GC-MS), and nuclear magnetic resonance spectroscopy (NMR). Before joining exponent, Ms. DeJoseph was a Research Assistant in the Medical School, Division of Epidemiology at Stanford University.



*This page intentionally left blank.*

## 5.0 Persons and Agencies Consulted

### 5.1 Federal Agencies

- United States Fish and Wildlife Service
- National Marine Fisheries Service
- United States Army Corps of Engineers

### 5.2 State Agencies

- Oregon State Office of Archaeology and Historic Preservation
- Oregon Department of Fish and Wildlife
- Oregon Department of Environmental Quality
- Oregon Division of State Lands
- Oregon Department of Land Conservation and State Lands
- Energy Facility Siting Council, Oregon Department of Energy
- Oregon Department of Transportation

### 5.3 Local Agencies

- Linn County Planning and Building Department
- Marion County Planning and Building Department
- Marion County Department of Community Development

### 5.4 Tribes

- Confederated Tribes of Grand Ronde

### 5.5 Utilities

- Portland General Electric

### 5.6 Landowners

There are approximately 100 landowners on the mailing list.



## 6.0 References

- Applied Archaeological Research. May 22, 2001. Results of a Cultural Resources Survey of the Bonneville Power Administration's Santiam-Bethel Tap Transmission Line Project, Marion County, Oregon. (Applied Archaeological Research Report No. 181) Portland, OR. Prepared for Bonneville Power Administration, Portland, OR.
- Bonneville Power Administration. 2000. Transmission system vegetation management program. Final environmental impact statement. DOE/EIS-0285. Portland, OR.
- Bracken, T. Dan. June 2001. Santiam-Bethel Transmission Project, *Appendix A, Electrical Effects*.
- Cowardin, L. M., V. Carter, F. C. Golet, and E. T. LaRoe. 1979. Classification of wetlands and deep water habitats of the United States. (FWS/OBS-79/31.) U.S. Fish and Wildlife Service. Washington, DC.
- Fennimore, Joe. June 8, 2001. Associate Planner, Marion County Community Development Department. Telephone conversation..
- Hopkins, S. Planner. May 1, 2001. Linn County Planning Department, OR. Telephone conversation.
- Hunt, W. April 30, 2001. Assistant district fish biologist. Oregon Department of Fish and Wildlife, Corvallis, OR. Telephone conversation.
- Jones & Stokes. May 17, 2001. Upgrade to the Bonneville Power Administration Santiam to Bethel, Oregon transmission line. Draft biological assessment. (J&S 0P008.01.) Bellevue, WA. Prepared for Bonneville Power Administration, Portland, OR.
- Linn County, Oregon. 2000. Linn County parks. Available: <<http://www.co.linn.or.us/>>. Accessed May 8, 2001.
- \_\_\_\_\_. 2001. Recreational facilities. Available: <<http://www.co.linn.or.us/>>. Accessed April 20, 2001.
- Marion County, Oregon. 2001. Recreational facilities. Available: <<http://www.co.marion.or.us>>. Accessed April 20, 2001.
- Maser, C. 1998. Mammals of the Pacific Northwest: from the coast to the high Cascades. Oregon State University Press. Corvallis, OR.
- McMaster, K. State Supervisor, USFWS Oregon State Office, Portland, OR. October 27, 2000 – letter to Leslie Kelleher of Bonneville Power Authority.
- Mitsch, W.J., and J.G. Gosselink. 1993. Wetlands. International Thomson Publishing. New York, NY.
- ODFW (Oregon Department of Fish and Wildlife). 1993. Oregon wildlife diversity plan. Portland, OR.

- ODFW. 1997. Oregon Department of Fish and Wildlife guidelines and criteria for stream-road crossings. Portland, OR.
- Oregon Department of Environmental Quality. 1998a. Map of 303(d) listed waterbodies and sub basin priorities. Available: <<http://waterquality.deq.state.or.us/WQLData/303dListMap.htm>>. Accessed April 26, 2001.
- Oregon Department of Environmental Quality. 1998b. Final 1998 303(d) file download page. Available: <<http://waterquality.deq.state.or.us/wq/303dlist/Download303d.htm>>. Accessed. April 26, 2001.
- Oregon Labor Market Information System. 2001. Oregon Employment Department unemployment and poverty statistics. Available: <<http://www.olmis.org>>. Accessed April 16, 2001.
- Oregon Natural Heritage Program. 2001. Natural Heritage database. Portland, OR.
- Oregon State University. 1997a. Oregon agriculture census, Linn County, 1997. Available: <<http://govinfo.library.orst.edu/cgi-bin/ag-list?01-043.orc>>. Accessed May 10, 2001.
- \_\_\_\_\_. 1997b. Oregon agriculture census, Linn County, 1997. Available: <<http://govinfo.library.orst.edu/cgi-bin/ag-list?28-043.orc>>. Accessed May 10, 2001.
- \_\_\_\_\_. 1997c. Oregon agriculture census, Marion County, 1997. Available: <<http://govinfo.library.orst.edu/cgi-bin/ag-list?01-047.orc>>. Accessed May 10, 2001.
- \_\_\_\_\_. 1997d. Oregon agriculture census, Marion County, 1997. Available: <<http://govinfo.library.orst.edu/cgi-bin/ag-list?28-047.orc>>. Accessed May 10, 2001.
- Oregon State University, Agricultural Extension. 1999. Oregon State University Extension agricultural statistics, Linn County, last updated April 23, 2001. Available: <<http://oregonstate.edu/extension/linn/Agstats1.html>>. Accessed May 10, 2001.
- Oregon State University, Extension Economic Information Office. 1999. Marion County agricultural commodity sales, 1999 (preliminary), last updated April 18, 2000. Available: <<http://www.open.org/~mcboc/agsales.htm>>. Accessed May 10, 2001.
- Portland State University Population Research Center. 2000. Population, ethnic, gender, and age distribution. Available: <<http://www.upa.pdx.edu/CPRC/>>. Accessed April 11, 2001.
- Salem OnLine. 2000. Salem OnLine. Available: <<http://www.salemlodging.com/index.html>>. Accessed May 8, 2001.
- U.S. Bureau of the Census. 1997. 1997 Model-based income and unemployment estimates. Available: <<http://www.census.gov>>. Accessed April 10, 2001.
- \_\_\_\_\_. 2000. 1999 unemployment rates. Available: <<http://www.census.gov>>. Accessed April 10, 2001.
- U.S. Bureau of Economic Analysis. 1998. Regional accounts data, employment sectors, annual earnings by industry sector, income and unemployment. Available: <<http://www.bea.doc.gov/bea/regional/reis/ca05>>. Accessed April 18, 2001.

USFWS (U.S. Fish and Wildlife Service). 1986. Recovery plan for the Pacific bald eagle. USDI Fish and Wildlife Service, Portland, OR.

USGS. 2000a. Groundwater atlas of the United States: Idaho, Oregon, and Washington. HA730-H. Available: <[http://capp.water.usgs.gov/gwa/ch\\_h/jpeg/H083.jpeg](http://capp.water.usgs.gov/gwa/ch_h/jpeg/H083.jpeg)>. Accessed April 30, 2001.

\_\_\_\_\_. 2000b. 1990 water use. Available: <<http://water.usgs.gov>>. Accessed April 30, 2001.

Wheeldon, Robert. June 6, 2001. Associate Planner, Linn County Planning and Building Department. Telephone conversation.



## 7.0 Glossary and Acronyms

### Acronyms

A	Ampere
BPA	Bonneville Power Administration
CWA	Clean Water Act
DLC	Donation Land Claim
EFH	Essential Fish Habitat
EMF	Electric and magnetic fields
EMI	Electromagnetic Interference
EPA	Environmental Protection Agency
ESU	Evolutionarily Significant Unit
FAA	Federal Aviation Administration
FCC	Federal Communication Commission
FEMA	Federal Emergency Management Agency
NAS	National Academy of Sciences
NEPA	National Environmental Policy Act
NESC	National Electrical Safety Code
NIEHS	National Institute of Environmental Health Sciences
NPDES	National Pollutant Discharge Elimination System
NRC	National Research Council
NWI	National Wetland Inventory
ODFW	Oregon Department of Fish and Wildlife
PEM	Palustrine emergent
PGE	Portland General Electric
PFO	Palustrine forested
PSS	Palustrine scrub-shrub
RI	Radio Interference
ROW	Right-of-way



SWPP	Stormwater Pollution Prevention
TVI	Television Interference
USFWS	U.S. Fish and Wildlife Service
USGS	U.S. Geological Service

### **Technical Terms**

Anadromous	Refers to fish such as salmon that hatch and rear in fresh water, move to the ocean to mature, and then return to fresh water to reproduce.
Alluvium	Material such as sand, silt, or clay that has been deposited on land by running water of streams and rivers.
Arcing	The process of current flowing across a gap, such as fault current flowing across an insulator string that flashed over due to a lightening strike.
Biological Assessment	A document required by the Endangered Species Act, which requires an evaluation of potential effects on listed species and critical habitat prior to implementing a proposed action. A proposed action is defined as any activity authorized, funded or carried out by a federal agency.
Blackouts	The disconnection of the source of electricity from all the electrical loads in a certain geographical area. Brought about by an emergency forced outage or other fault in the generation, transmission or distribution system serving the area.
Capacity	A measure of the ability of the transmission line to carry electricity.
Circuit	A system of conductors through which an electric current is intended to flow.
Conductor	Any metallic material, usually in the form of wire, cable, or bar, suitable for carrying an electrical current.
Corona	The phenomenon whereby the electric field associated with a power line cause ionization (molecular breakdown) of surrounding air, thus creating a high-frequency noise. This noise can be heard as static over an automobile radio when travelling under the power line.
Danger tree	Trees that pose a danger or hazard to the transmission line.
Double-circuit line	To place two separate electrical circuits on the same transmission structures or poles. Each circuit contains three separate conductors or bundles of conductors.

Floodplain	That portion of a river valley adjacent to the stream channel which is covered with water when the stream overflows its banks during flood stage.
Lattice steel	Refers to transmission towers constructed of multiple steel members that are connected together (usually in triangular shapes) to make up a frame.
Load	The amount of electric energy delivered or required at any specific point or points on a system. Load originates primarily at the energy using equipment of consumers, such as heaters, air conditioners, lights and motors. At BPA, load includes delivery to direct service industries (Note: Load is slightly larger than metered energy because of normal transmission and distribution losses in delivery from generator to consumer). Because loads are used to determine resource requirements, forecasts of electricity use are converted to loads.
Median	The middle number in a given sequence of numbers.
Mitigation	Steps taken to remove or lessen the effects predicted for each resource, as potentially caused by the transmission project. They may include reducing the impact, compensating for the impact, or avoiding it entirely. Some measures, such as adjusting the location of the towers to avoid a particular resource, are taken during the study and location process. Others, such as reseeding access roads, and/or avoiding the proliferation of weeds, are taken following project completion.
National Electrical Safety Code (NESC)	Written standards for the design, construction, maintenance and operation of electric supply and communication lines, equipment, and supply station in order to safeguard persons from hazards associated with those activities.
National Environmental Policy Act (NEPA)	A 1969 federal law that required evaluation of the environmental impact of federally funded projects and programs.
Noxious weeds	Plants that are injurious to public health, crops, livestock, land, or other property.
Outage	An event, caused by a disturbance on the electrical system, that requires BPA to remove a piece of equipment or a section of line from service. The disturbance can be either natural or caused by humans.
Overload	When too much current flows through transmission facilities that could cause damage or overheating. In the event of overloading, equipment has safeguards to disconnect it from the flow of electricity.

Palustrine emergent wetland	A shallow freshwater wetland characterized by erect, rotted, herbaceous hydrophytes (water loving plants).
Palustrine forested wetland	A wetland characterized by woody vegetation that is 20 feet or more in height.
Palustrine scrub-shrub wetland	A wetland dominated by woody vegetation less than 20 feet tall. This vegetation includes true shrubs, young trees, and trees and shrubs that are small or stunted because of environmental conditions.
Peak load	The maximum electrical load or the maximum average load during a designated interval such as 15 minutes.
Per capita	Per person
Reliability	The measure of the ability of a power system to provide uninterrupted service, even while that system is under stress.
Right-of-way (ROW)	An easement for a certain purpose over the land of another, such as a strip of land, electric transmission line ditch or pipeline. BPA usually acquires easements for its transmission lines, roads and other facilities such as guys and anchors.
Single-circuit	One electrical circuit consisting of three separate conductors or three bundles of conductors.
Substation	A non-generating electrical power station that serves to transform voltages to higher or lower levels, and that serves as a delivery point to individual customers such as utilities or large industrial plants. The BPA system has more than 400 substations.
Tap	A short transmission line that connects a substation to an existing transmission line.
Transmission grid	An interconnected network of transmission lines and associated equipment for the bulk transfer of electric energy between points of supply and demand. The BPA transmission grid includes some 22,500 circuit kilometers (14,00 circuit miles) of lines connecting more than 400 substations in the Pacific Northwest. The main grid consists of 230-kV, 345-kV, and 500-kV transmission lines.
Transmission line	A high-voltage power line used to carry electric power efficiently over long distances.
Voltage	The driving force that cause a current to flow in an electric circuit. Voltage and volt are often used interchangeably.
Wetlands	An area where the soil experiences anaerobic conditions because of inundation of water during part of any given year. Indicators of a wetland include types of plants, soil characteristics and hydrology.



**SANTIAM - BETHEL TRANSMISSION PROJECT**

**APPENDIX A**  
**ELECTRICAL EFFECTS**

June 2001

Prepared by  
**T. Dan Bracken, Inc.**

for  
**Bonneville Power Administration**



## Table of Contents

<b>1.0</b>	<b>Introduction</b> .....	<b>1</b>
<b>2.0</b>	<b>Physical Description</b> .....	<b>3</b>
2.1	Proposed Line.....	3
2.2	Existing Lines.....	3
<b>3.0</b>	<b>Electric Field</b> .....	<b>3</b>
3.1	Basic Concepts.....	3
3.2	Transmission-line Electric Fields.....	4
3.3	Calculated Values of Electric Fields.....	5
3.4	Environmental Electric Fields.....	6
<b>4.0</b>	<b>Magnetic Field</b> .....	<b>7</b>
4.1	Basic Concepts.....	7
4.2	Transmission-line Magnetic Fields.....	8
4.3	Calculated Values for Magnetic Fields.....	9
4.4	Environmental Magnetic Fields.....	9
<b>5.0</b>	<b>Electric and Magnetic Field (EMF) Effects</b> .....	<b>12</b>
5.1	Electric Fields: Short-term Effects.....	12
5.2	Magnetic Field: Short-term Effects.....	15
<b>6.0</b>	<b>Regulations</b> .....	<b>16</b>
<b>7.0</b>	<b>Audible Noise</b> .....	<b>17</b>
7.1	Basic Concepts.....	17
7.2	Transmission-line Audible Noise.....	19
7.3	Predicted Audible Noise Levels.....	19
7.4	Discussion.....	20
7.5	Conclusion.....	20
<b>8.0</b>	<b>Electromagnetic Interference</b> .....	<b>20</b>
8.1	Basic Concepts.....	20
8.2	Radio Interference (RI).....	21
8.3	Predicted RI Levels.....	21
8.4	Television Interference (TVI).....	22
8.5	Predicted TVI Levels.....	22
8.6	Interference with Other Devices.....	22
8.7	Conclusion.....	22
<b>9.0</b>	<b>Other Corona Effects</b> .....	<b>23</b>
<b>10.0</b>	<b>Summary</b> .....	<b>23</b>
	<b>List of References Cited</b> .....	<b>25</b>
	<b>List of Preparers</b> .....	<b>29</b>

## List of Tables

Table 1:	Physical and electrical characteristics of Santiam - Bethel Project corridors.....	31
Table 2:	Possible corridors for Santiam - Bethel Project .....	31
Table 3:	Calculated electric fields for configurations of the proposed Santiam - Bethel/ Santiam-Chemawa 230-kV line operated at maximum voltage .....	32
Table 4	Calculated magnetic fields for configurations of the proposed Santiam – Bethel/ Santiam - Chemawa 230-kV line operated at maximum current .....	33
Table 5	States with transmission-line field limits .....	34
Table 6	Common noise levels .....	35
Table 7	Typical sound attenuation (in decibels) provided by buildings .....	35
Table 8	Predicted foul-weather audible noise (AN) levels at edge of right-of-way (ROW) for proposed Santiam – Bethel/Santiam - Chemawa 230-kV line .....	36
Table 9	Predicted fair-weather radio interference (RI) levels at 100 feet (30.5 m) from the outside conductor of the proposed Santiam – Bethel/Santiam - Chemawa 230-kV line.....	36
Table 10	Predicted maximum foul-weather television interference (TVI) levels predicted at 100 feet (30.5 m) from the outside conductor of the proposed Santiam – Bethel/Santiam - Chemawa 230-kV line.....	37

## List of Figures

Figure 1	Configurations for proposed Santiam – Bethel/ Santiam- Chemawa 230-kV line: a) proposed line with no parallel lines (Configuration I); and b) proposed line with parallel 500-kV line (Configuration II).....	38
Figure 2	Electric-field profiles for configurations of proposed Santiam – Bethel/Santiam - Chemawa 230-kV line: a) proposed line with no parallel line (Configuration I); and b) proposed line with parallel 500-kV line (Configuration II) .....	39
Figure 3	Magnetic-field profiles for selected configurations of the proposed Santiam - Bethel/ Santiam – Chemawa 230-kV line for maximum current conditions: a) proposed line with no parallel line (Configuration I); and b) proposed line with parallel 500-kV line (Configuration II).....	40



# ELECTRICAL EFFECTS FROM THE PROPOSED SANTIAM - BETHEL TRANSMISSION PROJECT

## 1.0 Introduction

The Bonneville Power Administration (BPA) is proposing to build a 16.7-mile (mi.) (26.9-kilometer [km]) 230-kilovolt (kV) transmission line from the Santiam Substation near Stayton, Oregon, to a tap point on the existing PGE 230-kV Bethel line near Salem, Oregon. The proposed Santiam - Bethel Transmission Project would replace 16.7 mi. (26.9 km) of the single-circuit Santiam - Chemawa 230-kV line with a double-circuit 230-kV line. The proposed double-circuit line would consist of the new Santiam - Bethel 230-kV line and the rebuilt Santiam - Chemawa 230-kV line. Configurations along the existing line route include the right-of-way with no parallel lines (15.2 mi. or 24.5 km) and the right-of-way parallel to an existing 500-kV line (1.5 mi. or 2.4 km). The purpose of this report is to describe and quantify the electrical effects of the proposed Santiam - Bethel Transmission Project. These include the following:

- the levels of 60-hertz (Hz; cycles per second) electric and magnetic fields (EMF) at 3.28 feet (ft.) or 1 meter (m) above the ground,
- the effects associated with those fields,
- the levels of audible noise produced by the line, and
- electromagnetic interference associated with the line.

Electrical effects occur near all transmission lines, including those already present along the proposed route for the Santiam - Bethel line. Therefore, the levels of these quantities for the proposed line are computed and compared with those from the existing lines along the route.

The voltage on the conductors of transmission lines generates an electric field in the space between the conductors and the ground. The electric field is calculated or measured in units of volts-per-meter (V/m) or kilovolts-per-meter (kV/m) at a height of 3.28 ft. (1 m) above the ground. The current flowing in the conductors of the transmission line generates a magnetic field in the air and earth near the transmission line; current is expressed in units of amperes (A). The magnetic field is expressed in milligauss (mG), and is usually measured or calculated at a height of 3.28 ft. (1 m) above the ground. The electric field at the surface of the conductors causes the phenomenon of corona. Corona is the electrical breakdown or ionization of air in very strong electric fields, and is the source of audible noise, electromagnetic radiation, and visible light.

To quantify EMF levels along the route, the electric and magnetic fields from the proposed and existing lines were calculated using the BPA Corona and Field Effects Program (USDOE, undated). In this program, the calculation of 60-Hz fields uses standard superposition techniques for vector fields from several line sources: in this case, the line sources are transmission-line conductors. (Vector fields have both magnitude and direction: these must be taken into account when combining fields from different sources.) Important input parameters to the computer program are voltage, current, and geometric configuration of the line. The transmission-line conductors are assumed to be straight, parallel to each other, and located above and parallel to an infinite flat ground plane. Although such conditions do not

occur under real lines because of conductor sag and variable terrain, the validity and limitations of calculations using these assumptions have been well verified by comparisons with measurements. This approach was used to estimate fields for the proposed Santiam - Bethel line, where minimum clearances were assumed to provide worst-case (highest) estimates for the fields.

Electric fields are calculated using an imaging method. Fields from the conductors and their images in the ground plane are superimposed with the proper magnitude and phase to produce the total field at a selected location.

The total magnetic field is calculated from the vector summation of the fields from currents in all the transmission-line conductors. Balanced currents are assumed for each three-phase circuit; the contribution of induced image currents in the conductive earth is not included. Peak currents and power flow direction for the proposed and existing lines were provided by BPA and are based on the projected winter peak power loads in 2006. In the case of corridors with more than one line, calculations were performed for similar (maximum) current conditions on both lines.

Electric and magnetic fields for the proposed line were calculated at the standard height (3.28 ft. or 1 m) above the ground (IEEE, 1987). Calculations were performed out to 300 ft. (91 m) from the centerline of the existing corridor. The validity and limitations of such calculations have been well verified by measurements. Because maximum voltage, maximum current, and minimum conductor height above-ground are used, ***the calculated values given here represent worst-case conditions:*** i.e., the calculated fields are higher than they would be in practice. Such worst-case conditions would seldom occur.

The corona performance of the proposed line was also predicted using the BPA Corona and Field Effects Program (USDOE, undated). Corona performance is calculated using empirical equations that have been developed over several years from the results of measurements on numerous high-voltage lines (Chartier and Stearns, 1981; Chartier, 1983). The validity of this approach for corona-generated audible noise has been demonstrated through comparisons with measurements on other lines all over the United States (IEEE Committee Report, 1982). The accuracy of this method for predicting corona-generated radio and television interference from transmission lines has also been established (Olsen et al., 1992). Important input parameters to the computer program are voltage, current, conductor size, and geometric configuration of the line.

Corona is a highly variable phenomenon that depends on conditions along a length of line. Predictions of the levels of corona effects are reported in statistical terms to account for this variability. Calculations of audible noise and electromagnetic interference levels were made under conditions of an estimated average operating voltage (235 kV for the proposed line) and with the average line height (43 ft. or 13.1 m). Levels of audible noise, radio interference, and television interference are predicted for both fair and foul weather; however, corona is basically a foul-weather phenomenon. Wet conductors can occur during periods of rain, fog, snow, or icing. Along the route of the proposed Santiam - Bethel transmission line, such conditions are expected to occur about 22% of the time during a year, based on hourly records for the Salem airport from 1996 to 1999. Corona activity also increases with altitude. For purposes of evaluating corona effects from the proposed line, an altitude of 500 ft. (152 m) was assumed.

## **2.0 Physical Description**

### **2.1 Proposed Line**

The proposed double-circuit line would consist of two three-phase circuits, the new Santiam - Bethel 230-kV line and the rebuilt Santiam - Chemawa 230-kV line. Both circuits would have maximum phase-to-phase voltages of 242 kV. The average voltage of the lines would be 235 kV. The maximum electrical current on the lines would be 755 and 644 amperes per phase for the Santiam - Bethel and Santiam - Chemawa lines, respectively. The estimated currents are based on the BPA projected normal winter peak load in 2006. The load factor for these loads is 0.60 (average load = peak load x load factor). BPA provided the physical and operating characteristics of the proposed and existing lines.

The physical dimensions and electrical characteristics for the configuration of the proposed line are shown in Figure 1, and summarized in Table 1. Each phase of the proposed and rebuilt 230-kV lines will have a single 1.600-inch (in.) (4.1 centimeter [cm]) diameter steel-reinforced aluminum conductor (ACSR). Voltage and current waves are displaced by 120° in time (one-third of a cycle) on each electrical phase. The horizontal phase spacing between the upper and lower conductor positions of the two circuits would be 24.5 ft. (7.5 m); the horizontal spacing between the middle conductor positions would be 40.5 ft. (12.3 m). The vertical spacing between the conductor positions would be 18 ft. (5.5 m). Minimum conductor-to-ground clearance would be 31 ft. (9.5 m) at a conductor temperature of 122°F (50°C), which represents maximum operating conditions and high ambient air temperatures; clearances above ground would be greater under normal operating temperatures. The average clearance above ground along a span will be approximately 43 ft. (13.1 m); this value was used for corona calculations. At road crossings, the ground clearance would be at least 39 ft. (11.9 m). The 31-ft. (9.5-m) minimum clearance provided by BPA is greater than the minimum distance of the conductors above ground required to meet the National Electric Safety Code (NESC) (IEEE, 1990). The final design of the proposed line could entail larger clearances. The right-of-way width for the proposed line is 125 ft. (38 m).

### **2.2 Existing Lines**

The proposed double-circuit 230-kV line would replace a section of the existing Santiam - Chemawa 230-kV line along the entire route. There are two possible configurations along the existing Santiam - Chemawa line route: either no parallel line or parallel to the existing BPA Marion - Santiam No. 1 and No. 2 double-circuit 500-kV line (Table 2).

BPA provided information on currents for the existing Santiam - Chemawa line and for the Marion - Santiam No.1 500-kV line. The Marion - Santiam No. 2 line is not energized. The physical and electrical characteristics of the corridor configurations that were analyzed are given in Table 1; cross-sections of the corridors are shown in Figure 1.

## **3.0 Electric Field**

### **3.1 Basic Concepts**

An electric field is said to exist in a region of space if an electrical charge, at rest in that space, experiences a force of electrical origin (i.e., electric fields cause free charges to move). Electric field is a vector quantity: that is, it has both magnitude and direction. The direction corresponds to the direction

that a positive charge would move in the field. Sources of electric fields are unbalanced electrical charges (positive or negative) and time-varying magnetic fields. Transmission lines, distribution lines, house wiring, and appliances generate electric fields in their vicinity because of unbalanced electrical charge on energized conductors. The unbalanced charge is associated with the voltage on the energized system. On the power system in North America, the voltage and charge on the energized conductors are cyclic (plus to minus to plus) at a rate of 60 times per second. This changing voltage results in electric fields near sources that are also time-varying at a frequency of 60 hertz (Hz; a frequency unit equivalent to cycles per second).

As noted earlier, electric fields are expressed in units of volts per meter (V/m) or kilovolts (thousands of volts) per meter (kV/m). Electric- and magnetic-field magnitudes in this report are expressed in root-mean-square (rms) units. For sinusoidal waves, the rms amplitude is given as the peak amplitude divided by the square root of two.

The spatial uniformity of an electric field depends on the source of the field and the distance from that source. On the ground, under a transmission line, the electric field is nearly constant in magnitude and direction over distances of several feet (1 meter). However, close to transmission- or distribution-line conductors, the field decreases rapidly with distance from the conductors. Similarly, near small sources such as appliances, the field is not uniform and falls off even more rapidly with distance from the device. If an energized conductor (source) is inside a grounded conducting enclosure, then the electric field outside the enclosure is zero, and the source is said to be shielded.

Electric fields interact with the charges in all matter, including living systems. When a conducting object, such as a vehicle or person, is located in a time-varying electric field near a transmission line, the external electric field exerts forces on the charges in the object, and electric fields and currents are induced in the object. If the object is grounded, then the total current induced in the body (the "short-circuit current") flows to earth. The distribution of the currents within, say, the human body, depends on the electrical conductivities of various parts of the body: for example, muscle and blood have higher conductivity than bone and would therefore experience higher currents.

At the boundary surface between air and the conducting object, the field in the air and perpendicular to the conductor surface is much, much larger than the field in the conductor itself. For example, the average surface field on a human standing in a 10 kV/m field is 27 kV/m; the internal fields in the body are much smaller: approximately 0.008 V/m in the torso and 0.45 V/m in the ankles.

### **3.2 Transmission-line Electric Fields**

The electric field created by a high-voltage transmission line extends from the energized conductors to other conducting objects such as the ground, towers, vegetation, buildings, vehicles, and people. The calculated strength of the electric field at a height of 3.28 ft. (1 m) above an unvegetated, flat earth is frequently used to describe the electric field under straight parallel transmission lines. The most important transmission-line parameters that determine the electric field at a 1-m height are conductor height above ground and line voltage.

Calculations of electric fields from transmission lines are performed with computer programs based on well-known physical principles (cf., Deno and Zaffanella, 1982). The calculated values under these conditions represent an ideal situation. When practical conditions approach this ideal model, measurements and calculations agree. Often, however, conditions are far from ideal because of variable terrain and vegetation. In these cases, fields are calculated for ideal conditions, with the lowest conductor clearances to provide upper bounds on the electric field under the transmission lines. With the

use of more complex models or empirical results, it is also possible to account accurately for variations in conductor height, topography, and changes in line direction. Because the fields from different sources add vectorially, it is possible to compute the fields from several different lines if the electrical and geometrical properties of the lines are known. However, in general, electric fields near transmission lines with vegetation below are highly complex and cannot be calculated. Measured fields in such situations are highly variable.

For evaluation of EMF from transmission lines, the fields must be calculated for a specific line condition. The NESC states the condition for evaluating electric-field-induced short-circuit current for lines with voltage above 98 kV, line-to-ground, as follows: conductors are at a minimum clearance from ground corresponding to a conductor temperature of 120°F (49°C), and at a maximum voltage (IEEE, 1990). BPA has supplied the needed information for calculating electric and magnetic fields from the proposed transmission lines: the maximum operating voltage, the estimated peak current in 2006, and the minimum conductor clearances.

There are standard techniques for measuring transmission-line electric fields (IEEE, 1987). Provided that the conditions at a measurement site closely approximate those of the ideal situation assumed for calculations, measurements of electric fields agree well with the calculated values. If the ideal conditions are not approximated, the measured field can differ substantially from calculated values. Usually the actual electric field at ground level is reduced from the calculated values by various common objects that act as shields.

Maximum or peak field values occur over a small area at midspan, where conductors are closest to the ground. As the location of an electric-field profile approaches a tower, the conductor clearance increases, and the peak field decreases. A grounded tower will reduce the electric field considerably by shielding. For the parallel-line configuration considered here, minimum conductor clearances were assumed to occur along the same lateral profile for both lines. This condition will not necessarily occur in practice, because the towers for the parallel lines may be offset or located at different elevations. The assumption of simultaneous minimum clearance results in peak fields that may be larger than what occurs in practice.

For traditional transmission lines, such as the proposed line, where the right-of-way extends laterally well beyond the conductors, electric fields at the edge of the right-of-way are not as sensitive as the peak field to conductor height. Computed values at the edge of the right-of-way for any line height are fairly representative of what can be expected all along the transmission-line corridor. However, the presence of vegetation on and at the edge of the right-of-way will reduce actual electric-field levels below calculated values.

### **3.3 Calculated Values of Electric Fields**

Table 3 shows the calculated values of electric field at 3.28 ft. (1 m) above ground for the proposed Santiam - Bethel 230-kV transmission-line configurations. The peak value on the right-of-way and the value at the edge of the right-of-way are given for the two proposed corridor configurations and for minimum and average conductor clearances. Figure 2a shows lateral profiles for the electric field from the proposed and existing lines for the minimum conductor heights. Figure 2b shows calculated fields for the proposed and existing lines in the configuration with a parallel 500-kV line.

The calculated peak electric field expected on the right-of-way of the proposed line is 2.5 kV/m when there are no parallel lines. As shown in Figure 2a, the peak values would be present only at locations directly under the line, near mid-span, where the conductors are at the minimum clearance. The

conditions of minimum conductor clearance at maximum current and maximum voltage occur very infrequently. The calculated peak levels are rarely reached under real-life conditions, because the actual line height is generally above the minimum value used in the computer model, because the actual voltage is below the maximum value used in the model, and because vegetation within and near the edge of the right-of-way tends to shield the field at ground level. Maximum electric field under the existing parallel 500-kV is 8.1 kV/m.

The largest values expected at the edge of the right-of-way nearest the proposed line would be 0.4 kV/m. For the parallel configuration, the field at the edge of the right-of-way nearest the 500-kV line would be 0.3 kV/m. The largest electric fields at the edges of the existing rights-of-way are 1.3 and 2.6 kV/m for the 230- and 500-kV lines, respectively.

### **3.4 Environmental Electric Fields**

The electric fields associated with the Santiam - Bethel line can be compared with those found in other environments. Sources of 60-Hz electric (and magnetic) fields exist everywhere electricity is used; levels of these fields in the modern environment vary over a wide range. Electric-field levels associated with the use of electrical energy are orders of magnitude greater than the naturally occurring 60-Hz fields of about 0.0001 V/m, which stem from atmospheric and extraterrestrial sources.

Electric fields in outdoor, publicly accessible places range from less than 1 V/m to 12 kV/m; the large fields exist close to high-voltage transmission lines of 500 kV or higher. In remote areas without electrical service, 60-Hz field levels can be much lower than 1 V/m. Electric fields in home and work environments generally are not spatially uniform like those of transmission lines; therefore, care must be taken when making comparisons between fields from different sources such as appliances and electric lines. In addition, fields from all sources can be strongly modified by the presence of conducting objects. However, it is helpful to know the levels of electric fields generated in domestic and office environments in order to compare commonly experienced field levels with those near transmission lines.

Numerous measurements of residential electric fields have been reported for various parts of the United States, Canada, and Europe. Although there have been no large studies of residential electric fields, sufficient data are available to indicate field levels and characteristics. Measurements of domestic 60-Hz electric fields indicate that levels are highly variable and source-dependent. Electric-field levels are not easily predicted because walls and other objects act as shields, because conducting objects perturb the field, and because homes contain numerous localized sources. Internal sources (wiring, fixtures, and appliances) seem to predominate in producing electric fields inside houses. Average measured electric fields in residences are generally in the range of 5 to 20 V/m. In a large occupational exposure monitoring project that included electric-field measurements at homes, average exposures for all groups away from work were generally less than 10 V/m (Bracken, 1990).

Electric fields from household appliances are localized and decrease rapidly with distance from the source. Local electric fields measured at 1 ft. (0.3 m) from small household appliances are typically in the range of 30 to 60 V/m. Stopps and Janischewskyj (1979) reported electric-field measurements near 20 different appliances; at a 1-ft. (0.3-m) distance, fields ranged from 1 to 150 V/m, with a mean of 33 V/m. In another survey, reported by Deno and Zaffanella (1982), field measurements at a 1-ft. (0.3-m) distance from common domestic and workshop sources were found to range from 3 to 70 V/m. The localized fields from appliances are not uniform, and care should be taken in comparing them with transmission-line fields.

Electric blankets can generate higher localized electric fields. Sheppard and Eisenbud (1977) reported fields of 250 V/m at a distance of approximately 1 ft. (0.3 m). Florig et al. (1987) carried out extensive empirical and theoretical analysis of electric-field exposure from electric blankets and presented results in terms of uniform equivalent fields such as those near transmission lines. Depending on what parameter was chosen to represent intensity of exposure and the grounding status of the subject, the equivalent vertical 60-Hz electric-field exposure ranged from 20 to over 3500 V/m. The largest equivalent field corresponds to the measured field on the chest with the blanket-user grounded. The average field on the chest of an ungrounded blanket-user yields an equivalent vertical field of 960 V/m. As manufacturers have become aware of the controversy surrounding EMF exposures, electric blankets have been redesigned to reduce magnetic fields. However, electric fields from these “low field” blankets are still comparable with those from older designs (Bassen et al., 1991).

Generally, people in occupations not directly related to high-voltage equipment are exposed to electric fields comparable with those of residential exposures. For example, the average electric field measured in 14 commercial and retail locations in rural Wisconsin and Michigan was 4.8 V/m (ITT Research Institute, 1984). Median electric field was about 3.4 V/m. These values are about one-third the values in residences reported in the same study. Power-frequency electric fields near video display terminals (VTDs) are about 10 V/m, similar to those of other appliances (Harvey, 1983). Electric-field levels in public buildings such as shops, offices, and malls appear to be comparable with levels in residences.

In a survey of 1,882 volunteers from utilities, electric-field exposures were measured for 2,082 work days and 657 non-work days (Bracken, 1990). Electric-field exposures for occupations other than those directly related to high-voltage equipment were equivalent to those for non-work exposure.

Thus, except for the relatively few occupations where high-voltage sources are prevalent, electric fields encountered in the workplace are probably similar to those of residential exposures. Even in electric-utility occupations where high field sources are present, exposures to high fields are limited on average to minutes per day.

Electric fields found in publicly accessible areas near high-voltage transmission lines can typically range up to 3 kV/m for 230-kV lines, to 10 kV/m for 500-kV lines, and to 12 kV/m for 765-kV lines. Although these peak levels are considerably higher than the levels found in other public areas, they are present only in limited areas on rights-of-way.

The calculated electric fields for the proposed Santiam - Bethel 230-kV transmission line are consistent with the levels reported for other 230-kV transmission lines in Oregon and elsewhere. The electric fields on and at the edge of the right-of-way from the proposed line will be less than those from the Santiam - Chemawa 230-kV line that would be replaced. Electric fields from the existing 500-kV line will remain the same and be larger than those from the proposed or existing 230-kV lines. The calculated electric fields on the right-of-way of the proposed transmission line would be much higher than levels normally encountered in residences and offices.

## **4.0 Magnetic Field**

### **4.1 Basic Concepts**

Magnetic fields can be characterized by the force they exert on a moving charge or on an electrical current. As with the electric field, the magnetic field is a vector quantity characterized by both magnitude and direction. Electrical currents generate magnetic fields. In the case of transmission lines,

distribution lines, house wiring, and appliances, the 60-Hz electric current flowing in the conductors generates a time-varying, 60-Hz magnetic field in the vicinity of these sources. The strength of a magnetic field is measured in terms of magnetic lines of force per unit area, or magnetic flux density. The term “magnetic field,” as used here, is synonymous with magnetic flux density and is expressed in units of Gauss (G) or milligauss (mG).

The uniformity of a magnetic field depends on the nature and proximity of the source, just as the uniformity of an electric field does. Transmission-line-generated magnetic fields are quite uniform over horizontal and vertical distances of several feet near the ground. However, for small sources such as appliances, the magnetic field decreases rapidly over distances comparable with the size of the device.

The interaction of a time-varying magnetic field with conducting objects results in induced electric field and currents in the object. A changing magnetic field through an area generates a voltage around any conducting loop enclosing the area (Faraday's law). This is the physical basis for the operation of an electrical transformer. For a time-varying sinusoidal magnetic field, the magnitude of the induced voltage around the loop is proportional to the area of the loop, the frequency of the field, and the magnitude of the field. The induced voltage around the loop results in an induced electric field and current flow in the loop material. The induced current that flows in the loop depends on the conductivity of the loop.

## **4.2 Transmission-line Magnetic Fields**

The magnetic field generated by currents on transmission-line conductors extends from the conductors through the air and into the ground. The magnitude of the field at a height of 3.28 ft. (1 m) is frequently used to describe the magnetic field under transmission lines. Because the magnetic field is not affected by non-ferrous materials, the field is not influenced by normal objects on the ground under the line. The direction of the maximum field varies with location. (The electric field, by contrast, is essentially vertical near the ground.) The most important transmission-line parameters that determine the magnetic field at 3.28 ft. (1 m) height are conductor height above ground and magnitude of the currents flowing in the conductors. As distance from the transmission-line conductors increases, the magnetic field decreases.

Calculations of magnetic fields from transmission lines are performed using well-known physical principles (cf., Deno and Zaffanella, 1982). The calculated values usually represent the ideal straight parallel-conductor configuration. For simplicity, a flat earth is usually assumed. Balanced currents (currents of the same magnitude for each phase) are also assumed. This is usually valid for transmission lines, where loads on all three phases are maintained in balance during operation. Induced image currents in the earth are usually ignored for calculations of magnetic field under or near the right-of-way. The resulting error is negligible. Only at distances greater than 300 ft. (91 m) from a line do such contributions become significant (Deno and Zaffanella, 1982). The clearance for magnetic-field calculations for the proposed line was the same as that used for electric-field evaluations.

Standard techniques for measuring magnetic fields near transmission lines are described in ANSI IEEE Standard No. 644-1987 (1987). Measured magnetic fields agree well with calculated values, provided the currents and line heights that go into the calculation correspond to the actual values for the line. To realize such agreement, it is necessary to get accurate current readings during field measurements (because currents on transmission lines can vary considerably over short periods of time) and also to account for all field sources in the vicinity of the measurements.



As with electric fields, the maximum or peak magnetic fields occur in areas near the centerline and at midspan where the conductors are the lowest. The magnetic field at the edge of the right-of-way is not very dependent on line height. If more than one line is present, the peak field will depend on the relative electrical phasing of the conductors and the direction of power flow. Phasing information was available for the parallel 500-kV line. Phasing of the proposed line was selected to minimize magnetic field at the edge of the right-of-way.

### 4.3 Calculated Values for Magnetic Fields

Table 4 gives the calculated values of the magnetic field at 3.28 ft. (1 m) height for the proposed 230-kV transmission-line corridor. Field values on the right-of-way and at the edge of the right-of-way are given for projected maximum currents during winter peak load in 2006, for minimum and average conductor clearances. The maximum currents are 755 A on each of the three phases of the proposed Santiam - Bethel 230-kV line and 644 A on the rebuilt Santiam - Chemawa 230-kV line. Figure 3 shows lateral profiles of maximum magnetic field under this current condition for the two possible corridors of the proposed 230-kV transmission line. The actual magnetic-field levels would vary, as currents on the lines change daily and seasonally and as ambient temperature changes. Average currents over the year would be about 60% of the maximum values. The levels shown in the figures represent the highest magnetic fields expected for the proposed Santiam - Bethel/Santiam - Chemawa 230-kV line. Average fields over a year would be considerably reduced from the peak values, as a result of increased clearances above the minimum value and reduced currents from the maximum value.

The maximum calculated 60-Hz magnetic field expected at 3.28 ft. (1 m) above ground for the proposed line is 87 mG for the proposed line alone and 94 mG when the line parallels the 500-kV line. This field is calculated for the maximum current of 755 A, with the conductors at a height of 31 ft. (9.5 m). The maximum field would decrease for increased conductor clearance. For an average conductor height over a span of 43 ft. (13.1 m), the maximum field would be 50 mG and 58 mG for the proposed line alone and parallel to the 500-kV line, respectively.

At the edge of the right-of-way of the proposed line, the calculated magnetic field for maximum current load conditions is 26 mG. When the line is located parallel to the existing 500-kV line, the field at the edge of the right-of-way adjacent to the proposed line would be 29 mG.

The magnetic field falls off rapidly as distance from the line increases. At a distance of 200 ft. (61 m) from the centerline of the proposed line, the field would be 4 mG for maximum current conditions. The calculated magnetic field for maximum current would be less than 10 mG at about 120 ft. (37 m) from the centerline.

The calculated fields for the two corridors with existing transmission lines are given in Table 4. For the existing lines, the peak magnetic fields on the rights-of-way are 218 mG and 108 mG, for the 230- and 500-kV lines, respectively. Fields at the edges of the existing rights-of-way are 78 mG and 50 mG for the 230- and 500-kV lines, respectively. Addition of the proposed line will not significantly change the magnetic fields under, or at the edge of, the right-of-way of the existing 500-kV line.

### 4.4 Environmental Magnetic Fields

Transmission lines are not the only source of magnetic fields; as with 60-Hz electric fields, 60-Hz magnetic fields are present throughout the environment of a society that relies on electricity as a principal energy source. The magnetic fields associated with the proposed Santiam - Bethel 230-kV line can be compared with fields from other sources. The range of 60-Hz magnetic-field exposures in publicly

accessible locations such as open spaces, transmission-line rights-of-way, streets, pedestrian walkways, parks, shopping malls, parking lots, shops, hotels, public transportation, and so on range from less than 0.1 mG to about 1 G, with the highest values occurring near small appliances with electric motors. In occupational settings in electric utilities, where high currents are present, magnetic-field exposures for workers can be above 1 G. At 60 Hz, the magnitude of the natural magnetic field is approximately 0.0005 mG.

Several investigations of residential fields have been conducted. In a large study to identify and quantify significant sources of 60-Hz magnetic fields in residences, measurements were made in 996 houses, randomly selected throughout the country (Zaffanella, 1993). The most common sources of residential fields were power lines, the grounding system of residences, and appliances. Field levels were characterized by both point-in-time (spot) measurements and 24-hour measurements. Spot measurements averaged over all rooms in a house exceeded 0.6 mG in 50% of the houses and 2.9 mG in 5% of houses. Power lines generally produced the largest average fields in a house over a 24-hour period. On the other hand, grounding system currents proved to be a more significant source of the highest fields in a house. Appliances were found to produce the highest local fields; however, fields fell off rapidly with increased distance. For example, the median field near microwave ovens was 36.9 mG at a distance of 10.5 in. (0.27 m) and 2.1 mG at 46 in. (1.17 m). Across the entire sample of 996 houses, higher magnetic fields were found in, among others, urban areas (vs. rural); multi-unit dwellings (vs. single-family); old houses (vs. new); and houses with grounding to a municipal water system.

In an extensive measurement project to characterize the magnetic-field exposure of the general population, over 1000 randomly selected persons in the United States wore a personal exposure meter for 24 hours and recorded their location in a simple diary (Zaffanella and Kalton, 1998). Based on the measurements of 853 persons, the estimated 24-hour average exposure for the general population is 1.24 mG and the estimated median exposure is 0.88 mG. The average field "at home, not in bed" is 1.27 mG and "at home, in bed" is 1.11 mG. Average personal exposures were found to be largest "at work" (mean of 1.79 mG and median of 1.01 mG) and lowest "at home, in bed" (mean of 1.11 mG and median of 0.49 mG). Average fields in school were also low (mean of 0.88 mG and median of 0.69 mG). Factors associated with higher exposures at home were smaller residences, duplexes and apartments, metallic rather than plastic water pipes, and nearby overhead distribution lines.

As noted above, magnetic fields from appliances are localized and decrease rapidly with distance from the source. Localized 60-Hz magnetic fields have been measured near about 100 household appliances such as ranges, refrigerators, electric drills, food mixers, and shavers (Gauger, 1985). At a distance of 1 ft. (0.3 m), the maximum magnetic field ranged from 0.3 to 270 mG, with 95% of the measurements below 100 mG. Ninety-five percent of the levels at a distance of 4.9 ft. (1.5 m) were less than 1 mG. Devices that use light-weight, high-torque motors with little magnetic shielding exhibited the largest fields. These included vacuum cleaners and small hand-held appliances and tools. Microwave ovens with large power transformers also exhibited relatively large fields. Electric blankets have been a much-studied source of magnetic-field exposure because of the length of time they are used and because of the close proximity to the body. Florig and Hoburg (1988) estimated that the average magnetic field in a person using an electric blanket was 15 mG, and that the maximum field could be 100 mG. New "low-field" blankets have magnetic fields at least 10 times lower than those from conventional blankets (Bassen et al., 1991).

In a domestic magnetic-field survey, Silva et al. (1989) measured fields near different appliances at locations typifying normal use (e.g., sitting at a typewriter or standing at a stove). Specific appliances with relatively large fields included can openers (n = 9), with typical fields ranging from 30 to 225 mG and a maximum value up to 2.7 G; shavers (n = 4), with typical fields from 50 to 300 mG and maximum

fields up to 6.9 G; and electric drills ( $n = 2$ ), with typical fields from 56 to 190 mG and maximum fields up to 1.5 G. The fields from such appliances fall off very rapidly with distance and are only present for short periods. Thus, although instantaneous magnetic-field levels close to small hand-held appliances can be quite large, they do not contribute to average area levels in residences.

Although studies of residential magnetic fields have not all considered the same independent parameters, the following consistent characterization of residential magnetic fields emerges from the data:

- (1) External sources play a large role in determining residential magnetic-field levels. Transmission lines, when nearby, are an important external source. Unbalanced ground currents on neutral conductors and other conductors, such as water pipes in and near a house, can represent a significant source of magnetic field. Distribution lines per se, unless they are quite close to a residence, do not appear to be a traditional distance-dependent source.
- (2) Homes with overhead electrical service appear to have higher average fields than those with underground service.
- (3) Appliances represent a localized source of magnetic fields that can be much higher than average or area fields. However, fields from appliances approach area levels at distances greater than 3 ft. (1 m) from the device.

Although important variables in determining residential magnetic fields have been identified, quantification and modeling of their influence on fields at specific locations is not yet possible. However, a general characterization of residential magnetic-field level is possible: average levels in the United States are in the range of 0.5 to 1.0 mG, with the average field in a small number of homes exceeding this range by as much as a factor of 10 or more. Average personal exposure levels are slightly higher, possibly due to use of appliances and varying distances to other sources. Maximum fields can be much higher.

Magnetic fields in commercial and retail locations are comparable with those in residences. As with appliances, certain equipment or machines can be a local source of higher magnetic fields. Utility workers who work close to transformers, generators, cables, transmission lines, and distribution systems clearly experience high-level fields. Other sources of fields in the workplace include motors, welding machines, computers, and video display terminals (VDTs). In publicly accessible indoor areas, such as offices and stores, field levels are generally comparable with residential levels, unless a high-current source is nearby.

Because high-current sources of magnetic field are more prevalent than high-voltage sources, occupational environments with relatively high magnetic fields encompass a more diverse set of occupations than do those with high electric fields. For example, in occupational magnetic-field measurements reported by Bowman et al. (1988), the geometric mean field from 105 measurements of magnetic field in "electrical worker" job locations was 5.0 mG. "Electrical worker" environments showed the following elevated magnetic-field levels (geometric mean greater than 20 mG): industrial power supplies, alternating current (ac) welding machines, and sputtering systems for electronic assembly. For secretaries in the same study, the geometric mean field was 3.1 mG for those using VDTs ( $n = 6$ ) and 1.1 mG for those not using VDTs ( $n = 3$ ).

Measurements of personal exposure to magnetic fields were made for 1,882 volunteer utility workers for a total of 4,411 workdays (Bracken, 1990). Median workday mean exposures ranged from 0.5 mG for clerical workers without computers to 7.2 mG for substation operators. Occupations not specifically associated with transmission and distribution facilities had median workday exposures less than 1.5 mG,

while those associated with such facilities had median exposures above 2.3 mG. Magnetic-field exposures measured in homes during this study were comparable with those recorded in offices.

Magnetic fields in publicly accessible outdoor areas seem to be, as expected, directly related to proximity to electric-power transmission and distribution facilities. Near such facilities, magnetic fields are generally higher than indoors (residential). Higher-voltage facilities tend to have higher fields. Typical maximum magnetic fields in publicly accessible areas near transmission facilities can range from less than a few milligauss up to 300 mG or more, near heavily loaded lines operated at 230 to 765 kV. The levels depend on the line load, conductor height, and location on the right-of-way. Because magnetic fields near high-voltage transmission lines depend on the current in the line, they can vary daily and seasonally. To characterize fields from the distribution system, Heroux (1987) measured 60-Hz magnetic fields with a mobile platform along 140 mi. (223 km) of roads in Montreal. The median field level averaged over nine different routes was 1.6 mG, with 90% of the measurements less than about 5.1 mG. Spot measurements indicated that typical fields directly above underground distribution systems were 5 to 19 mG. Beneath overhead distribution lines, typical fields were 1.5 to 5 mG on the primary side of the transformer, and 4 to 10 mG on the secondary side. Near ground-based transformers used in residential areas, fields were 80 to 1000 mG at the surface and 10 to 100 mG at a distance of 1 ft. (0.3 m).

The magnetic fields from the proposed 230-kV transmission line would be less than those from the existing 230-kV line that is being replaced. The fields from the proposed line would be comparable to or less than those from existing 230-kV lines in Oregon and elsewhere. On and near the right-of-way of the proposed line, magnetic fields would be well above average residential levels. However, the fields from the line would decrease rapidly and approach common ambient levels at distances greater than a few hundred feet from the line. Furthermore, the fields at the edge of the right-of-way would not be above those encountered during normal activities near common sources such as hand-held appliances.

## **5.0 Electric and Magnetic Field (EMF) Effects**

Possible effects associated with the interaction of EMF from transmission lines with people on and near a right-of-way fall into two categories: short-term effects that can be perceived and may represent a nuisance, and possible long-term health effects. Only short-term effects are discussed here. The issue of whether there are long-term health effects associated with transmission-line fields is controversial. In recent years, considerable research on possible biological effects of EMF has been conducted. A review of these studies and their implications for health-related effects is provided in a separate technical report for the environmental assessment for the proposed Santiam - Bethel 230-kV transmission line.

### **5.1 Electric Fields: Short-term Effects**

Short-term effects from transmission-line electric fields are associated with perception of induced currents and voltages or perception of the field. Induced current or spark discharge shocks can be experienced under certain conditions when a person contacts objects in an electric field. Such effects occur in the fields associated with transmission lines that have voltages of 230-kV or higher. These effects could occur infrequently under the proposed Santiam - Bethel 230-kV line. The higher electric fields under the existing 500-kV Marion-Santiam line are much more likely to result in such effects.

Steady-state currents are those that flow continuously after a person contacts an object and provides a path to ground for the induced current. The amplitude of the steady-state current depends on the induced current to the object in question and on the grounding path. The magnitude of the induced current to vehicles and objects under the proposed line will depend on the electric-field strength and the size and

shape of the object. When an object is electrically grounded, the voltage on the object is reduced to zero, and it is not a source of current or voltage shocks. If the object is poorly grounded or not grounded at all, then it acquires some voltage relative to earth and is a possible source of current or voltage shocks.

The responses of persons to steady-state current shocks have been extensively studied, and levels of response documented (Keesey and Letcher, 1969; IEEE, 1978). Primary shocks are those that can result in direct physiological harm. Such shocks will not be possible from induced currents under the existing or proposed lines, because clearances above ground required by the NESC preclude such shocks from large vehicles and grounding practices eliminate large stationary objects as sources of such shocks.

Secondary shocks are defined as those that could cause an involuntary and potentially harmful movement, but no direct physiological harm. Secondary shocks could occur under the proposed 230-kV line when making contact with ungrounded conducting objects such as vehicles or equipment. However, such occurrences are anticipated to be very infrequent. Shocks, when they occur under the 230-kV line, are most likely to be below the nuisance level. Induced currents are extremely unlikely to be perceived off the right-of-way of the proposed line.

Induced currents are always present in electric fields under transmission lines and will be present near the proposed line. However, during initial construction, BPA routinely grounds metal objects that are located on or near the right-of-way. The grounding eliminates these objects as sources of induced current and voltage shocks. Multiple grounding points are used to provide redundant paths for induced current flow. After construction, BPA would respond to any complaints and install or repair grounding to mitigate nuisance shocks.

Unlike fences or buildings, mobile objects such as vehicles and farm machinery cannot be grounded permanently. Limiting the possibility of induced currents from such objects to persons is accomplished in several ways. First, required clearances for above-ground conductors tend to limit field strengths to levels that do not represent a hazard or nuisance. The NESC (IEEE, 1990) requires that, for lines with voltage exceeding 98 kV line-to-ground (170 kV line-to-line), sufficient conductor clearance be maintained to limit the induced short-circuit current in the largest anticipated vehicle under the line to 5 milliamperes (mA) or less. This can be accomplished by limiting access or by increasing conductor clearances in areas where large vehicles could be present. BPA and other utilities design and operate lines to be in compliance with the NESC.

For the proposed line, conductor clearances (50°C conductor temperature) would be increased to at least 39 ft. (11.9 m) over road crossings along the route, resulting in a maximum field of 1.7 kV/m or less at the 3.28 ft. (1 m) height. The largest truck allowed on roads in Oregon without a special permit is 14 feet high by 8.5 feet wide by 75 feet long (4.3 x 2.6 x 22.9 m). The induced currents to such a vehicle oriented perpendicular to the line in a maximum field of 1.7 kV/m (at 3.28-foot height) would be less than 1.5 mA (Reilly, 1979). For smaller trucks, the maximum induced currents for perpendicular orientation to the proposed line would be less than this value. (Larger special-permitted trucks, such as triple trailers, can be up to 105 feet in length. However, because they average the field over such a long distance, the maximum induced current to a 105-foot vehicle oriented perpendicular to the 230-kV line at a road crossing would be less than 1.4 mA.) Thus, the NESC 5-mA criterion would be met for perpendicular road crossings of the proposed line. These large vehicles are not anticipated to be off highways or oriented parallel to the proposed line. Even if they were, the NESC 5-mA criterion would be met under the proposed line. As discussed below, these are worst-case estimates of induced currents at road crossings; conditions for their occurrence are rare. The conductor clearance at each road crossing would be checked during the design stage of the line to ensure that the NESC 5-mA criterion is met. Furthermore, it is BPA policy to limit the maximum induced current from vehicles to 2 mA in

commercial parking lots. Line clearances would also be increased in accordance with the NESC, such as over railroads and water areas suitable for sailboating.

Several factors tend to reduce the levels of induced current shocks from vehicles:

- (1) Activities are distributed over the whole right-of-way, and only a small percentage of time is spent in areas where the field is at or close to the maximum value.
- (2) At road crossings, vehicles are aligned perpendicular to the conductors, resulting in a substantial reduction in induced current.
- (3) The conductor clearance at road crossings may not be at minimum values because of lower conductor temperatures and/or location of the road crossing away from midspan.
- (4) The largest vehicles are permitted only on certain highways.
- (5) Off-road vehicles are in contact with soil or vegetation, which reduces shock currents substantially.

Induced voltages occur on objects, such as vehicles, in an electric field where there is an inadequate electrical ground. If the voltage is sufficiently high, then a spark discharge shock can occur as contact is made with the object. Such shocks are similar to "carpet" shocks that occur, for example, when a person touches a doorknob after walking across a carpet on a dry day.

In electric fields higher than will occur under the proposed line, it is theoretically possible for a spark discharge from the induced voltage on a large vehicle to ignite gasoline vapor during refueling. The probability for exactly the right conditions to occur for ignition is extremely remote. The additional clearance of conductors provided at road crossings reduces the electric field in areas where vehicles are prevalent and reduces the chances for such events. Even so, BPA recommends that vehicles should not be refueled under the proposed line unless specific precautions are taken to ground the vehicle and the fueling source (USDOE, 1995).

Under certain conditions, the electric field can be perceived through hair movement on an upraised hand or arm of a person standing on the ground under high-voltage transmission lines. The median field for perception in this manner was 7 kV/m for 136 persons; only about 12% could perceive fields of 2 kV/m or less (Deno and Zaffanella, 1982). Even in areas under the conductors at midspan, the fields at ground level would be below the levels where field perception normally occurs. Therefore, it is unlikely that the field would be perceived anywhere on the right-of-way. Where vegetation provides shielding, the field would not be perceived.

Conductive shielding reduces both the electric field and induced effects such as shocks. Persons inside a vehicle cab or canopy are shielded from the electric field. Similarly, a row of trees or a lower-voltage distribution line reduces the field on the ground in the vicinity. Metal pipes, wiring, and other conductors in a residence or building shield the interior from the transmission-line electric field.

Thus, potential impacts of electric fields can be mitigated through grounding policies, adherence to the NESC, and increased clearances above the minimums specified by the NESC. Worst-case levels are used for safety analyses but, in practice, induced currents and voltages are reduced considerably by unintentional grounding. Shielding by conducting objects, such as vehicles and vegetation, also reduces the potential for electric-field effects.

The electric fields from the proposed 230-kV line will be less than those from the line it is replacing. Therefore the potential for impacts of electric fields will be reduced from that now present on the existing right-of-way. The potential for effects from the parallel 500-kV line will remain the same.

## **5.2 Magnetic Field: Short-term Effects**

Magnetic fields associated with transmission and distribution systems can induce voltage and current in long conducting objects that are parallel to the transmission line. As with electric-field induction, these induced voltages and currents are a potential source of shocks. A fence, irrigation pipe, pipeline, electrical distribution line, or telephone line forms a conducting loop when it is grounded at both ends. The earth forms the other portion of the loop. The magnetic field from a transmission line can induce a current to flow in such a loop if it is oriented parallel to the line. If only one end of the fence is grounded, then an induced voltage appears across the open end of the loop. The possibility for a shock exists if a person closes the loop at the open end by contacting both the ground and the conductor. The magnitude of this potential shock depends on the following factors: the magnitude of the field; the length of the object (the longer the object, the larger the induced voltage); the orientation of the object with respect to the transmission line (parallel as opposed to perpendicular, where no induction would occur); and the amount of electrical resistance in the loop (high resistance limits the current flow).

Magnetically induced currents from power lines have been investigated for many years; calculation methods and mitigating measures are available. A comprehensive study of gas pipelines near transmission lines developed prediction methods and mitigation techniques specifically for induced voltages on pipelines (Dabkowski and Taflove, 1979; Taflove and Dabkowski, 1979). Similar techniques and procedures are available for irrigation pipes and fences. Grounding policies employed by utilities for long fences reduce the potential magnitude of induced voltage.

The magnitude of the coupling with both pipes and fences is very dependent on the electrical unbalance (unequal currents) among the three phases of the line. Thus, a distribution line where a phase outage may go unnoticed for long periods of time can represent a larger source of induced currents than a transmission line where the loads are well-balanced (Jaffa and Stewart, 1981).

Knowledge of the phenomenon, grounding practices, and the availability of mitigation measures mean that magnetic-induction effects from the proposed 230-kV transmission line will be minimal.

Magnetic fields from transmission and distribution facilities can interfere with certain electronic equipment. Magnetic fields can cause distortion of the image on VDTs and computer monitors. The threshold field for interference depends on the type and size of monitor and the frequency of the field. Interference has been observed for certain monitors at fields at or below 10 mG (Baishiki et al., 1990; Banfai et al., 2000). Generally, the problem arises when computer monitors are in use near electrical distribution facilities in large office buildings. Fields from the proposed line would fall below this level at approximately 120 ft. (37 m) from the centerline.

Interference from magnetic fields can be eliminated by shielding the affected monitor or moving it to an area with lower fields. Similar mitigation methods could be applied to other sensitive electronics, if necessary. Interference from 60-Hz fields with computers and control circuits in vehicles and other equipment is not anticipated at the field levels found under and near the proposed 230-kV transmission line.

The magnetic fields from the proposed line will be less than those from the existing line that is being replaced. Therefore the potential for impacts from magnetic fields will be reduced from that on the existing right-of-way. The potential for effects from the parallel 500-kV line will remain the same.

## **6.0 Regulations**

Regulations that apply to transmission-line electric and magnetic fields fall into two categories. Safety standards or codes are intended to limit or eliminate electric shocks that could seriously injure or kill persons. Field limits or guidelines are intended to limit electric- and magnetic-field exposures that can cause nuisance shocks or might cause health effects. In no case has a limit or standard been established because of a known or demonstrated health effect.

The proposed line would be designed to meet the NESC (IEEE, 1990), which specifies how far transmission-line conductors must be from the ground and other objects. The clearances specified in the code provide safe distances that prevent harmful shocks to workers and the public. In addition, people who live and work near transmission lines must be aware of safety precautions to avoid electrical (which is not necessarily physical) contact with the conductors. For example, farmers should not up-end irrigation pipes under a transmission or other electrical line. In addition, as a matter of safety, the NESC specifies that electric-field-induced currents from transmission lines must be below the 5 mA (“let go”) threshold deemed a lower limit for primary shock. BPA publishes and distributes a brochure that describes safe practices to protect against shock hazards around power lines (USDOE, 1995).

Field limits or guidelines have been adopted in several states and countries and by national and international organizations. Electric-field limits have generally been based on minimizing nuisance shocks or field perception. The intent of magnetic-field limits has been to limit exposures to existing levels, given the uncertainty of their potential for health effects.

There are currently no national standards in the United States for 60-Hz electric and magnetic fields. Several states have been active in establishing mandatory or suggested limits on 60-Hz electric and (in two cases) magnetic fields. Six states have specific electric-field limits that apply to transmission lines: Florida, Minnesota, Montana, New Jersey, New York, and Oregon. Florida and New York have established regulations for magnetic fields. These regulations are summarized in Table 5, adapted from TDHS Report (1989).

Electric-field limits for the states have been given in terms of maximum field or edge-of-right-of-way field, or both. The Oregon limit of 9 kV/m for electric fields is applied to areas accessible to the public (Oregon, 1980). The Oregon rule, which is found in transmission-line siting procedures also addresses grounding practices, audible noise, and radio interference.

Government agencies and utilities operating transmission systems have established design criteria that include EMF levels. BPA has maximum allowable electric fields of 9 and 5 kV/m on and at the edge of the right-of-way, respectively (USDOE, 1996). BPA also has maximum-allowable electric field strengths of 5 kV/m, 3.5 kV/m, and 2.5 kV/m for road crossings, shopping center parking lots, and commercial/industrial parking lots, respectively. These levels are based on limiting the maximum short-circuit currents from anticipated vehicles to less than 1 mA in shopping center lots and to less than 2 mA in commercial parking lots.

Electric-field limits for overhead power lines have also been established in other countries (Maddock, 1992). Limits for magnetic fields from overhead power lines have not been explicitly established



anywhere except in Florida and New York. However, general guidelines and limits on EMF have been established for occupational and public exposure in several countries and by national and international organizations.

The American Conference of Governmental Industrial Hygienists (ACGIH) sets guidelines (Threshold Limit Values or TLV) for occupational exposures to environmental agents (ACGIH, 2000). In general, a TLV represents the level below which it is believed that nearly all workers may be exposed repeatedly without adverse health effects. For EMF, the TLVs represent ceiling levels. For 60-Hz electric fields, occupational exposures should not exceed the TLV of 25 kV/m. However, the ACGIH also recognizes the potential for startle reactions from spark discharges and short-circuit currents in fields greater than 5-7 kV/m, and recommends implementing grounding practices. They recommend the use of conductive clothing for work in fields exceeding 15 kV/m. The TLV for occupational exposure to 60-Hz magnetic fields is a ceiling level of 10 G (10,000 mG) (ACGIH, 2000).

Electric and magnetic fields from various sources (including automobile ignitions, appliances, and, possibly, transmission lines) can interfere with implanted cardiac pacemakers. In light of this potential problem, manufacturers design devices to be immune from such interference. However, research has shown that these efforts have not been completely successful and that a few models of pacemakers could be affected by 60-Hz fields from transmission lines. There were also numerous models of pacemakers that were not affected by fields even larger than those found under transmission lines. Because of the known potential for interference with pacemakers by 60-Hz fields, field limits for pacemaker wearers have been established by the ACGIH. They recommend that wearers of pacemakers and similar medical-assist devices limit their exposure to electric fields of 1 kV/m or less and to magnetic fields to 1 G (1,000 mG) or less (ACGIH, 2000).

The International Committee on Non-ionizing Radiation Protection (ICNIRP), working in cooperation with the World Health Organization (WHO) has developed guidelines for occupational and public exposures to EMF (ICNIRP, 1998). For occupational exposures at 60 Hz, the recommended limits to exposure are 8.3 kV/m for electric fields and 4.2 G (4,200 mG) for magnetic fields. The electric-field level can be exceeded, provided precautions are taken to prevent spark discharge and induced current shocks. For the general public, the ICNIRP guidelines recommend exposure limits of 4.2 kV/m for electric fields and 0.83 G (830 mG) for magnetic fields (ICNIRP, 1998).

ICNIRP has also established guidelines for contact currents, which could occur when a grounded person contacts an ungrounded object in an electric field. The guideline levels are 1.0 mA for occupational exposure and 0.5 mA for public exposure.

The estimated peak electric field and magnetic field on, and at the edge of, the right-of-way of the proposed transmission line would meet limits set in all states, including Oregon. The electric fields from the proposed 230-kV line would meet the ACGIH standards, provided wearers of pacemakers and similar medical-assist devices are discouraged from unshielded right-of-way use. (A passenger in an automobile under the line would be shielded from the electric field.) The electric fields from the proposed line would meet the ICNIRP guideline for public exposure. The magnetic fields from the proposed line would be below the ACGIH and IRPA/INIRC limits. The electric fields present on the right-of-way could induce currents in ungrounded vehicles that exceeded the ICNIRP level of 0.5 mA.

## **7.0 Audible Noise**

### **7.1 Basic Concepts**

Audible noise (AN), as defined here, represents an unwanted sound, as from a transmission line, transformer, airport, or vehicle traffic. Sound is a pressure wave caused by a sound source vibrating or displacing air. The ear converts the pressure fluctuations into auditory sensations. AN from a source is superimposed on the background or ambient noise that is present before the source is introduced.

The amplitude of a sound wave is the incremental pressure resulting from sound above atmospheric pressure. The sound-pressure level is the fundamental measure of AN; it is generally measured on a logarithmic scale with respect to a reference pressure. The sound-pressure level (SPL) in decibels (dB) is given by:

$$\text{SPL} = 20 \log (P/P_0)\text{dB}$$

where P is the effective rms (root-mean-square) sound pressure,  $P_0$  is the reference pressure, and the logarithm (log) is to the base 10. The reference pressure for measurements concerned with hearing is usually taken as 20 micropascals (Pa), which is the approximate threshold of hearing for the human ear. A logarithmic scale is used to encompass the wide range of sound levels present in the environment. The range of human hearing is from 0 dB up to about 140 dB, a ratio of 10 million in pressure (EPA, 1978).

Logarithmic scales, such as the decibel scale, are not directly additive: to combine decibel levels, the dB values must be converted back to their respective equivalent pressure values, the total rms pressure level found, and the dB value of the total recalculated. For example, adding two sounds of equal level on the dB scale results in a 3 dB increase in sound level. Such an increase in sound pressure level of 3 dB, which corresponds to a doubling of the energy in the sound wave, is barely discernible by the human ear. It requires an increase of about 10 dB in SPL to produce a subjective doubling of sound level for humans. The upper range of hearing for humans (140 dB) corresponds to a sharply painful response (EPA, 1978).

Humans respond to sounds in the frequency range of 16 to 20,000 Hz. The human response depends on frequency, with the most sensitive range roughly between 2000 and 4000 Hz. The frequency-dependent sensitivity is reflected in various weighting scales for measuring audible noise. The A-weighted scale weights the various frequency components of a noise in approximately the same way that the human ear responds. This scale is generally used to measure and describe levels of environmental sounds such as those from vehicles or occupational sources. The A-weighted scale is also used to characterize transmission-line noise. Sound levels measured on the A-scale are expressed in units of dB(A) or dBA.

AN levels and, in particular, corona-generated audible noise (see below) vary in time. In order to account for fluctuating sound levels, statistical descriptors have been developed for environmental noise. Exceedence levels (L levels) refer to the A-weighted sound level that is exceeded for a specified percentage of the time. Thus, the  $L_5$  level refers to the noise level that is exceeded only 5% of the time.  $L_{50}$  refers to the sound level exceeded 50% of the time. Sound-level measurements and predictions for transmission lines are often expressed in terms of exceedence levels, with the  $L_5$  level representing the maximum level and the  $L_{50}$  level representing a median level.

Table 6 shows AN levels from various common sources. Clearly, there is wide variation. Noise exposure depends on how much time an individual spends in different locations. Outdoor noise generally does not contribute to indoor levels (EPA, 1974). Activities in a building or residence generally dominate interior AN levels. The amount of sound attenuation (reduction) provided by buildings is given in Table 7. Assuming that residences along the line route fall in the "warm climate, windows open" category, the typical sound attenuation provided by a house is about 12 dBA.

The BPA design criterion for corona-generated audible noise ( $L_{50}$ , foul weather) is  $50 \pm 2$  dBA at the edge of the ROW. This criterion has been interpreted by the state and BPA to meet Oregon Noise Control Regulations (Perry, 1982). The Environmental Protection Agency (EPA) has established a guideline of 55 dBA for the annual average day-night level ( $L_{dn}$ ) in outdoor areas (EPA, 1978). In computing this value, a 10 dB correction (penalty) is added to night-time noise between the hours of 10 p.m. and 7 a.m.

## 7.2 Transmission-line Audible Noise

Corona is the partial electrical breakdown of the insulating properties of air around the conductors of a transmission line. In a small volume near the surface of the conductors, energy and heat are dissipated. Part of this energy is in the form of small local pressure changes that result in audible noise. Corona-generated audible noise can be characterized as a hissing, crackling sound that, under certain conditions, is accompanied by a 120-Hz hum.

Corona-generated audible noise is of concern primarily for contemporary lines operating at voltages of 345 kV and higher during foul weather. Thus in the area where the proposed 230-kV line parallels a 500-kV line, audible noise from the higher voltage line will predominate. In other areas, the proposed 230-kV line will produce some noise under foul-weather conditions.

The conductors of high-voltage transmission lines are designed to be corona-free under ideal conditions. However, protrusions on the conductor surface—particularly water droplets on or dripping off the conductors—cause electric fields near the conductor surface to exceed corona onset levels, and corona occurs. Therefore, audible noise from transmission lines is generally a foul-weather (wet-conductor) phenomenon. Wet conductors can occur during periods of rain, fog, snow, or icing. Based on meteorologic records near the route of the proposed transmission line, such conditions are expected to occur less than 22% of the time during the year. For a few months after line construction, residual grease or oil on the conductors can cause water to bead up on the surface. This results in more corona sources and slightly higher levels of audible noise and electromagnetic interference if the line is energized. However, the new conductors "age" in a few months, and the level of corona activity decreases to the predicted equilibrium value. During fair weather, insects and dust on the conductor can also serve as sources of corona. The proposed line has been designed with 1.600-in. (4.1-cm) diameter conductors that will yield acceptable corona levels.

## 7.3 Predicted Audible Noise Levels

The predicted levels of corona-generated audible noise for the proposed line operated at a voltage of 235 kV are given in Table 8. For comparison, Table 8 also gives the calculated levels for the existing lines. Audible noise levels are calculated for average voltage and average conductor heights for fair- and foul-weather conditions. The calculated median level ( $L_{50}$ ) during foul weather at the edge of the proposed Santiam - Bethel right-of-way is about 39 dBA, which is less than that from the existing Santiam - Chemawa 230-kV line. Where the proposed Santiam - Bethel line parallels the Marion - Santiam 500-kV line, noise from the higher-voltage line will predominate and there would be no change in noise levels from existing conditions. For this configuration, the noise at the edge of the right-of-way near the proposed line would be 47 dBA.

During fair-weather conditions, which occur about 78% of the time, audible noise levels at the edge of the right-of-way would be about 20 dBA lower (if corona were present). These lower levels could be masked by ambient noise on and off the right-of-way.

## 7.4 Discussion

The calculated foul-weather corona noise levels for the proposed line would be less than those under the existing conditions and comparable to or less than those from existing 230-kV lines in Oregon. During fair weather, noise from the conductors might be perceivable on the right-of-way, but beyond the right-of-way it would likely be masked or so low as to not be perceived even during foul weather when ambient noise is higher.

Off the right-of-way, the levels of audible noise from the proposed line would be well below the 55 dBA level that can produce interference with speech outdoors. Since residential buildings provide significant sound attenuation (-12 dBA with windows open; -24 dBA with windows closed), the noise levels off the right-of-way would be well below the 45 dBA level required for interference with speech indoors and well below the 35 dBA level where sleep interference can occur (EPA, 1973; EPA, 1978). Since corona is a foul-weather phenomenon, people tend to be inside with windows possibly closed, providing additional attenuation when corona noise is present. In addition, ambient noise levels can be high during such periods (due to rain hitting foliage or buildings), and can mask corona noise.

The 39-dBA and 47-dBA levels would meet the BPA design criterion and, hence, the Oregon Noise Control Regulations for transmission lines. The 2 dBA decrease in noise at the edge of the right-of-way associated with the proposed line would probably not be discernible.

The computed annual  $L_{dn}$  level for transmission lines operating in areas with about 22% foul weather is about  $L_{dn} = L_{50} + 1$  dB (Bracken, 1987). Therefore, assuming such conditions in the Santiam - Bethel area, the estimated  $L_{dn}$  at the edge of the right-of-way would be approximately 40 or 48 dBA, which is below the EPA  $L_{dn}$  guideline of 55 dBA.

## 7.5 Conclusion

Along the proposed line route, there would be slight decreases, or no change, in the perceived noise above ambient levels during foul weather at the edges of the right-of-way. Along the existing corridor, the corona-generated noise during foul weather would be masked to some extent by naturally occurring sounds such as wind and rain on foliage. During fair weather, the noise off the right-of-way from the proposed line would probably not be detectable above ambient levels. However, noise from the existing 500-kV line could be perceived as much as under existing conditions. The noise levels from the proposed line would be below levels identified as causing interference with speech or sleep. The audible noise from the transmission line would be below EPA guideline levels and would meet the BPA design criterion that complies with the Oregon State noise regulations.

## 8.0 Electromagnetic Interference

### 8.1 Basic Concepts

Corona on transmission-line conductors can also generate electromagnetic noise in the frequency bands used for radio and television signals. The noise can cause radio and television interference (RI and TVI). In certain circumstances, corona-generated electromagnetic interference (EMI) can also affect communications systems and other sensitive receivers. Interference with electromagnetic signals by corona-generated noise is generally associated with lines operating at voltages of 345 kV or higher. This is especially true of interference with television signals. The 1.600-in. (4.1-cm) diameter conductor used

in the design of the proposed 230-kV line will mitigate corona generation and thus keep radio and television interference levels at acceptable levels.

Spark gaps on distribution lines and on low-voltage wood-pole transmission lines are a more common source of RI/TVI than is corona from high-voltage electrical systems. This gap-type interference is primarily a fair-weather phenomenon caused by loose hardware and wires. The proposed transmission line would be constructed with modern hardware that eliminates such problems and therefore minimizes gap noise. Consequently, this source of EMI is not anticipated for the proposed line.

No state has limits for either RI or TVI. In the United States, electromagnetic interference from power transmission systems is governed by the Federal Communications Commission (FCC) Rules and Regulations presently in existence (FCC, 1988). A power transmission system falls into the FCC category of "incidental radiation device," which is defined as "a device that radiates radio frequency energy during the course of its operation although the device is not intentionally designed to generate radio frequency energy." Such a device "shall be operated so that the radio frequency energy that is emitted does not cause harmful interference. In the event that harmful interference is caused, the operator of the device shall promptly take steps to eliminate the harmful interference." For purposes of these regulations, harmful interference is defined as: "any emission, radiation or induction which endangers the functioning of a radio navigation service or of other safety services or seriously degrades, obstructs or repeatedly interrupts a radio communication service operating in accordance with this chapter" (FCC, 1988: Vol II, part 15. 47CFR, Ch. 1).

Electric power companies have been able to work quite well under the present FCC rule because harmful interference can generally be eliminated. It has been estimated that more than 95% of power-line sources that cause interference are due to gap-type discharges. These can be found and completely eliminated, when required to prevent interference (USDOE, 1980). Complaints related to corona-generated interference occur infrequently. This is especially true with the advent of cable television and satellite television, which are not subject to corona-generated interference. Mitigation of corona-generated interference with conventional radio and television receivers can be accomplished in several ways, such as use of a directional antenna or relocation of an existing antenna (USDOE, 1977; USDOE, 1980; Loftness et al., 1981).

## **8.2 Radio Interference (RI)**

Radio reception in the AM broadcast band (535 to 1605 kilohertz (kHz)) is most often affected by corona-generated EMI. FM radio reception is rarely affected. Generally, only residences very near to transmission lines can be affected by RI. The IEEE Radio Noise Design Guide identifies an acceptable limit of fair-weather RI as expressed in decibels above 1 microvolt per meter (dB $\mu$ V/m) of about 40 dB $\mu$ V/m at 100 ft. (30 m) from the outside conductor (IEEE Committee Report, 1971). As a general rule, average levels during foul weather (when the conductors are wet) are 16 to 22 dB $\mu$ V/m higher than average fair-weather levels.

## **8.3 Predicted RI Levels**

Table 9 gives the predicted fair- and foul-weather RI levels at 100 ft. (30 m) from the outside conductor for the proposed 230-kV line in the two corridor configurations. Median foul-weather levels would be about 17 dB higher than the fair-weather levels. The predicted L<sub>50</sub> fair-weather level at the edge of the right-of-way is 34 dB $\mu$ V/m for 235-kV line operation; at 100 ft. (30 m) from the outside conductor, the level is 26 dB $\mu$ V/m. Predicted fair-weather L<sub>50</sub> levels are lower than that from the existing 230-kV Santiam - Chemawa 230-kV line. Predictions indicate that fair-weather RI will meet the IEEE

40 dB $\mu$ V/m criterion at distances greater than about 10 ft. (3 m) from the outside conductor of the proposed line.

#### **8.4 Television Interference (TVI)**

Corona-caused TVI occurs during foul weather and is generally of concern for transmission lines with voltages of 345 kV or above, and only for conventional receivers within about 600 ft. (183 m) of a line. As is the case for RI, gap sources on distribution and low-voltage transmission lines are the principal observed sources of TVI. The use of modern hardware and construction practices for the proposed line would minimize such sources.

#### **8.5 Predicted TVI Levels**

Table 10 shows TVI levels predicted at 100 ft. (30 m) from the outside conductor of the proposed line operating at 235 kV and from existing lines. At this distance, the foul-weather TVI level predicted for the proposed line is 10 dB $\mu$ V/m. This level is lower than that from the existing Santiam - Chemawa 230-kV line. Replacement of the existing line with the proposed line will reduce TVI levels along the right-of-way.

Other forms of TVI from transmission lines are signal reflection (ghosting) and signal blocking caused by the relative locations of the transmission structure and the receiving antenna with respect to the incoming television signal. The proposed structures are steel and larger than the existing wood structures; they could cause reflection or ghosting and affect reception in rare instances. Television systems that operate at higher frequencies, such as satellite receivers, are not affected by corona-generated TVI. Cable television systems are similarly unaffected.

Interference with television reception can be corrected by any of several approaches: improving the receiving antenna system; installing a remote antenna; installing an antenna for TV stations less vulnerable to interference; connecting to an existing cable system; or installing a translator (cf. USDOE, 1977). BPA has an active program to identify, investigate, and mitigate legitimate RI and TVI complaints. It is anticipated that any instances of TVI caused by the proposed line could be effectively mitigated.

#### **8.6 Interference with Other Devices**

Corona-generated interference can conceivably cause disruption on other communications bands such as the citizen's (CB) and mobile bands. However, mobile-radio communications are not susceptible to transmission-line interference because they are generally frequency modulated (FM). Similarly, cellular telephones operate at a frequency of about 900 MHz, which is above the frequency where corona-generated interference is prevalent. In the unlikely event that interference occurs with these or other communications, mitigation can be achieved with the same techniques used for television and AM radio interference. However, the addition of the proposed line would lower interference levels in the corridor; consequently, no impact is anticipated.

#### **8.7 Conclusion**

Predicted EMI levels for the proposed 230-kV transmission line are lower than those that already exist 230-kV lines; no impacts of corona-generated interference on radio, television, or other reception are anticipated above those already present. Furthermore, if interference should occur, there are various methods for correcting it: BPA has a program to respond to legitimate complaints.

## 9.0 Other Corona Effects

Corona is visible as a bluish glow or as bluish plumes. On the proposed 230-kV line, corona levels would be very low, so that corona on the conductors would be observable only under the darkest conditions and only with the aid of binoculars, if at all. Without a period of adaptation for the eyes and without intentional looking for the corona, it would not be noticeable.

When corona is present, the air surrounding the conductors is ionized and many chemical reactions take place, producing small amounts of ozone and other oxidants. Ozone is approximately 90% of the oxidants, while the remaining 10% is composed principally of nitrogen oxides. The national primary ambient air quality standard for photochemical oxidants, of which ozone is the principal component, is 235 micrograms/cubic meter) or 120 parts per billion. The maximum incremental ozone levels at ground level produced by corona activity on the proposed transmission line during foul weather would be much less than 1 part per billion. This level is insignificant when compared with natural levels and fluctuations in natural levels.

## 10.0 Summary

Electric and magnetic fields from the proposed transmission line have been characterized using well-known techniques accepted within the scientific and engineering community. The expected electric-field levels from the proposed line at minimum design clearance would be less than those from the existing line in the corridor and comparable to, or less than, those from other 230-kV lines in Oregon and elsewhere. The expected magnetic-field levels from the proposed line would be less than those from the existing line that would be replaced and comparable to, or less than, those from other 230-kV lines in Oregon and elsewhere.

The peak electric field expected under the proposed line would be 2.5 kV/m; the maximum value at the edge of the right-of-way would be about 0.4 kV/m. Clearances at road crossings would be increased to reduce the peak electric-field value to 1.7 kV/m.

Under maximum current conditions, the maximum magnetic fields under the proposed line would be 96 mG; at the edge of the right-of-way nearest to the proposed 230-kV line, the magnetic field would be 29 or 26 mG, depending on whether the line parallels an existing 500-kV line or not.

The electric and magnetic fields from the proposed line would meet regulatory limits for public exposure in Oregon and other states with limits. As long as cardiac pacemaker wearers are discouraged from using the right-of-way, the field levels meet the guidelines for exposure established by ACGIH and ICNIRP.

Short-term effects from transmission-line fields are well understood and can be mitigated. Nuisance shocks arising from electric-field induced currents and voltages could be perceivable on the right-of-way of the proposed line. BPA will ground permanent conducting objects during and after construction to mitigate against such occurrences. Since the fields from the proposed line are less than those from the existing line on the corridor, the potential for such effects could be reduced.

Corona-generated audible noise from the line would be less than from the existing 230-kV transmission lines on the corridor. Audible noise levels would be in compliance with noise regulations in Oregon and would be below levels specified in EPA guidelines.

Corona-generated electromagnetic interference from the proposed line would be less than that from the existing 230-kV line on the corridor and would remain below limits identified as acceptable. In the unlikely event that legitimate complaints arise, BPA has a mitigation program to identify and correct reception problems.



## List of References Cited

- ACGIH (American Conference of Governmental Industrial Hygienists). 2000. 2000 TLVs and BEIs: Threshold Limit Values for Chemical Substances and Physical Agents and Biological Exposure Indices. American Conference of Governmental Industrial Hygienists, Cincinnati. 192 pages.
- Baishiki, R.S.; Johnson, G.B.; Zaffanella, L.E.; Bracken, T.D.; Sussman, S.S.; Rauch, G.B.; and Silva, J.M. 1990. Studies of Power System Magnetic Fields: Characterization of Sources in Residential Environments, Measurement of Exposure, Influence On Computer Screens. (36-104) CIGRE, Paris, France. 10 pages.
- Banfai, B.; Karady, G.G.; Kim, C.J.; and Maracas, K.B. 2000. Magnetic field effects on CRT computer monitors. *IEEE Trans. on Power Delivery* 15, 307-312.
- Bassen, H.; Casamento, J.; and Crawl, B. 1991. Reduction of electric and magnetic field emissions from electric blankets (Meeting abstract). *In: Bioelectromagnetics Society, 13th Annual Meeting, 23-27 June, Salt Lake City. Bioelectromagnetics Society, New York, 20.*
- Bowman, J.D.; Garabrant, D.H.; Sobel, E.; and Peters, J.M. June 1988. Exposures to Extremely Low Frequency (ELF) Electromagnetic Fields in Occupations With Elevated Leukemia Rates. *Applied Industrial Hygienics*, 3(6, June):189-194.
- Bracken, T.D. 1987. Audible Noise from High Voltage Transmission Facilities. A Briefing Paper Prepared for State of Florida Department of Environmental Regulation. (DER Contract No. SP122) State of Florida Department of Environmental Regulation.
- Bracken, T.D. 1990. The EMDEX Project: Technology Transfer and Occupational Measurements, Volumes 1-3 Interim Report. EPRI Report EN-7048. (EPRI EN-7048) Electric Power Research Institute, Palo Alto, CA.
- Chartier, V.L. April 1983. Empirical Expressions for Calculating High Voltage Transmission Corona Phenomena, First Annual Seminar Technical Career Program for Professional Engineers. Bonneville Power Administration, Portland, Oregon. April 1983, 75-82.
- Chartier, V.L.; and Stearns, R.D. January 1981. Formulas for Predicting Audible Noise from Overhead High Voltage AC and DC Lines. *IEEE Transactions on Power Apparatus and Systems*, PAS-100(No. 1, January 1981):121-129.
- Dabkowski, J.; and Taflove, A. May/June 1979. Prediction Method for Buried Pipeline Voltages Due to 60 Hz AC Inductive Coupling. Part II: Field Test Verification. *IEEE Transactions on Power Apparatus and Systems*, PAS-98(3, May/June):788-794.
- Deno, D.W.; and Zaffanella, L. 1982. Field effects of overhead transmission lines and stations. Chap. 8. *In: Transmission Line Reference Book: 345 KV and Above. Second ed. (Ed: LaForest, J.J.). Electric Power Research Institute, Palo Alto, CA, 329-419.*
- EPA (Environmental Protection Agency). July 1973. Public Health and Welfare Criteria for Noise. (No. 500/9-73-002, July 27, 1973.) U.S. Environmental Protection Agency, Washington, D.C.

- EPA. 1974. Information On Levels of Environmental Noise Requisite to Protect Public Health and Welfare With an Adequate Margin of Safety. (No. PB-239 429.) U.S. Environmental Protection Agency, Washington, D.C.
- EPA. 1978. Protective Noise Levels. Condensed Version of EPA Levels Document. (No. PB82-138827) U.S Environmental Protection Agency, Washington, DC.
- FCC (Federal Communications Commission). 1988. Federal Communications Commission Rules and Regulations. 10-1-88 ed. Vol. II part 15, 47 CFR, Ch. 1.
- Florig, H.K.; and Hoburg, J.F. 1988. Electric and Magnetic Field Exposure Associated With Electric Blankets. Project Resume. Contractor's Review. U.S. Department of Energy/Electric Power Research Institute.
- Florig, H.K.; Hoburg, J.F.; and Morgan, M.G. April 1987. Electric Field Exposure from Electric Blankets. IEEE Transactions on Power Delivery, PWRD-2(2, April):527-536.
- Gauger, J. September 1985. Household Appliance Magnetic Field Survey. IEEE Transactions on Power Apparatus and Systems, 104(9, September):2436-2445.
- Harvey, S.M. 1983. Analysis of operator exposure to electric fields from video display units. Chap. 2. In Video Display Units--Characterization of Electric and Magnetic Fields. (Ontario Hydro Research Division Report # 83-503-K) (Ed: Walsh, M.L.). Ontario Hydro, Toronto, 31-56.
- Heroux, P. 1987. 60-Hz Electric and Magnetic Fields Generated By a Distribution Network. Bioelectromagnetics, 8(2):135-148.
- ICNIRP (International Committee on Non-ionizing Radiation Protection). April 1998. Guidelines for Limiting Exposure to Time-Varying Electric, Magnetic, and Electromagnetic Fields (Up to 300 GHz). Health Physics, 74(4, April):1-32.
- IEEE (Institute of Electrical and Electronics Engineers, Inc.). 1978. Electric and Magnetic Field Coupling from High Voltage AC Power Transmission Lines -- Classification of Short-Term Effects On People. IEEE Transactions on Power Apparatus and Systems, PAS-97:2243-2252.
- IEEE. 1987. IEEE Standard Procedures for Measurement of Power Frequency Electric and Magnetic Fields from AC Power Lines. ANSI/IEEE Std. 644-1987, New York, NY.
- IEEE. 1990. National Electrical Safety Code. 1990 ed. Institute of Electrical and Electronics Engineers, Inc., New York, NY. 432 pages.
- IEEE Committee Report. March/April 1971. Radio Noise Design Guide for High Voltage Transmission Lines. IEEE Transactions on Power Apparatus and Systems, PAS-90(No. 2, March/April):833-842.
- IEEE Committee Report. October 1982. A Comparison of Methods for Calculating Audible Noise of High Voltage Transmission Lines. IEEE Transactions on Power Apparatus and Systems, 101(10, October):4090-4099.
- ITT Research Institute. 1984. Representative Electromagnetic Field Intensities Near the Clam Lake (WI) and Republic (MI) ELF Facilities. Report Prepared for Naval Electronics Systems

- Command, PME 110 E Washington, D.C. 20360. (Under contract N00039-84-C0070.) ITT Research Institute, Chicago, IL. 60 pages.
- Jaffa, K.C.; and Stewart, J.B. March 1981. Magnetic Field Induction from Overhead Transmission and Distribution Power Lines On Buried Irrigation Pipelines. *IEEE Transactions on Power Apparatus and Systems*, PAS-100(3, March):990-1000.
- Keeseey, J.C.; and Letcher, F.S. 1969. Minimum Thresholds for Physiological Responses to Flow of Alternating Electric Current Through the Human Body At Power-Transmission Frequencies. (Report No. 1) Naval Medical Research Institute, Project MR 005.08-0030B, Bethesda, MD. 25 pages.
- Loftness, M.O.; Chartier, V.L.; and Reiner, G.L. 1981. EMI Correction Techniques for Transmission Line Corona. (August 18-20, 1981, pp. 351-361.) Proceedings of the 1981 IEEE International Symposium on Electromagnetic Compatibility, Boulder, CO.
- Maddock, B.J. September 1992. Guidelines and Standards for Exposure to Electric and Magnetic Fields At Power Frequencies. (Panel 2-05, CIGRE meeting August 30-September 5, 1992) CIGRE, Paris.
- Olsen, R.G.; Schennum, S.D.; and Chartier, V.L. April 1992. Comparison of Several Methods for Calculating Power Line Electromagnetic Interference Levels and Calibration With Long Term Data. *IEEE Transactions on Power Delivery*, 7(April, 1992):903-913.
- Oregon, State of. 1980. Oregon Administrative Rules Chapter 345, Division 80. Energy Facility Siting Council standards relating to public health and safety, 934-80-055.
- Perry, D. 1982. Sound Level Limits from BPA Facilities. BPA memorandum, May 26, 1982; Department of Environmental Quality, Noise Control Regulations, Chapter 340, Oregon Administrative Rules, Division 35, March 1, 1978.
- Reilly, J.P. 1979. Electric Field Induction on Long Objects—A Methodology for Transmission Line Impact Studies. *IEEE Transactions on Power Apparatus and Systems*, PAS-98(6, Nov/Dec):1841-1852.
- Sheppard, A.R.; and Eisenbud, M. 1977. Biological Effects of Electric and Magnetic Fields of Extremely Low Frequency. New York University Press, New York.
- Silva, M.; Hummon, N.; Rutter, D.; and Hooper, C. 1989. Power Frequency Magnetic Fields in the Home. *IEEE Transactions on Power Delivery*, 4:465-478.
- Stoppa, G.J.; and Janischewskyj, W. 1979. Epidemiological Study of Workers Maintaining HV Equipment and Transmission Lines in Ontario. (Canadian Electrical Association Research Report) Canadian Electrical Association, Montreal. 82 pages.
- Taflove, A.; and Dabkowski, J. May/June 1979. Prediction Method for Buried Pipeline Voltages Due to 60 Hz AC Inductive Coupling. Part I: Analysis. *IEEE Transactions on Power Apparatus and Systems*, PAS-98(3, May/June):780-787.

- TDHS Report. March 1989. EMF Rule Becomes Law; Hillsborough County Commission Challenges. Transmission/Distribution Health & Safety Report, 7(9, 31 March):1-3.
- TDHS Report. August 1990. Updates: New York. Transmission/Distribution Health & Safety Report, 8(7, 31 August):4.
- USDOE (U.S. Department of Energy), Bonneville Power Administration. March 1977. A Practical Handbook for the Location, Prevention and Correction of Television Interference from Overhead Power Lines. Portland, OR.
- USDOE, Bonneville Power Administration. May 1980. A Practical Handbook for the Correction of Radio Interference from Overhead Powerlines and Facilities. (May 1980.) Portland, OR.
- USDOE, Bonneville Power Administration. 1995. Living and Working Around High-Voltage Power Lines. (DOE/BP-799). Portland, OR. 9 pages.
- USDOE, Bonneville Power Administration. 1996. Electrical and Biological Effects of Transmission Lines: A Review. (DOE/BP 2938 December 1996 1M) Portland, OR.
- USDOE, Bonneville Power Administration. undated. "Corona and Field Effects" Computer Program (Public Domain Software). Bonneville Power Administration, P.O. Box 491-ELE, Vancouver, WA 98666.
- Zaffanella, L.E. 1993. Survey of Residential Magnetic Field Sources. Vol. 1: Goals, results, and conclusions. (EPRI TR-102759-V1, Project 3335-02) Electric Power Research Institute, Palo Alto, CA.
- Zaffanella, L.E.; and Kalton, G.W. 1998. Survey of personal magnetic field exposure, Phase II: 1000-person survey. Interim Report. EMF RAPID Program Engineering Project #6. Eneritech Consultants, Lee, MA.

## **List of Preparers**

T. Dan Bracken was the principal author of this report. He received a B.S. degree in physics from Dartmouth College and M.S. and Ph.D. degrees in physics from Stanford University. Dr. Bracken has been involved with research on and characterization of electric- and magnetic-field effects from transmission lines for over 27 years, first as a physicist with the Bonneville Power Administration (BPA) (1973 - 1980) and since then as a consultant. His firm, T. Dan Bracken, Inc., offers technical expertise in areas of electric- and magnetic-field measurements, instrumentation, environmental effects of transmission lines, exposure assessment and project management. Joseph Dudman of T. Dan Bracken, Inc., provided data entry, graphics, and clerical support in the preparation of the report.

Judith H. Montgomery of Judith H. Montgomery/Communications served as technical editor for the report. She holds an A.B. degree in English literature from Brown University, 1966; and a Ph.D. degree in American literature from Syracuse University, 1971. Dr. Montgomery has provided writing, editing, and communications services to government and industry for 20 years. Her experience includes preparation of National Environmental Policy Act documents and technical papers dealing with transmission-line environmental impact assessment and other utility-related activities.

(This page intentionally left blank.)

**Table 1: Physical and electrical characteristics of Santiam - Bethel Project corridors**

Configuration	New Line	Existing Corridors	
	I	I	II
Description	Santiam - Bethel/Santiam - Chemawa 230-kV	Santiam - Chemawa 230-kV	Marion - Santiam No. 1 & No. 2 500-kV
Voltage, kV Maximum/Average <sup>1</sup>	242/235	242/235	550/540, 0/0
Peak Current, A Existing/Proposed	-/755, -/644	1043/-	-889/-992, 0/0
Electric Phasing	B C A B C A	C B A	B B A C A C
Clearance, ft. Minimum/Average <sup>1</sup>	31/43	31/43	38/47
Centerline Distance from Santiam - Bethel, ft.	-	-	125
Centerline distance to edge of right-of-way (ROW), ft.	62.5	62.5	82.5
Tower configuration	Vertical double-circuit	Horizontal	Delta double-circuit
Phase spacing, ft.	24.5H, 40.5H 18V	27H	25.5H, 36.75V
Conductor: #/Diameter, in.	1/1.600	1/1.100	3/1.302

<sup>1</sup> Average voltage and average clearance used for corona calculations.

**Table 2: Possible corridors for Santiam - Bethel Project**

Configuration	Description of other lines in corridor with Santiam - Bethel/Santiam - Chemawa 230-kV line	Miles
I	Santiam - Bethel/Santiam - Chemawa 230-kV double-circuit line only	15.2
II	BPA Marion - Santiam 500-kV No. 1 and No. 2 double circuit line	1.5

**Table 3: Calculated electric fields for configurations of the proposed Santiam - Bethel/Santiam - Chemawa 230-kV line operated at maximum voltage.** Configurations are described in Tables 1 and 2.

a) **Configuration I: Santiam - Bethel/Santiam - Chemawa 230-kV line only**

Configuration	Proposed I		Existing	
ROW width, ft. (m)	125 (38)		125 (38)	
Line	Santiam - Bethel/Santiam - Chemawa 230-kV		Santiam - Chemawa 230-kV	
Clearance	Min.	Avg.	Min.	Avg.
Peak field, kV/m	2.5	1.5	3.0	1.8
Edge of ROW, kV/m	0.3	0.4	1.3	1.1

b) **Configuration II: Santiam - Bethel/Santiam - Chemawa 230-kV and Marion - Santiam 500-kV No. 1 and No. 2 lines**

Configuration	Proposed II				Existing			
ROW width, ft. (m)	270 (82)				270 (82)			
Line	Santiam - Bethel/ Santiam - Chemawa 230-kV		Marion - Santiam No. 1 and No. 2 500-kV		Santiam - Chemawa 230-kV		Marion - Santiam No. 1 and No. 2 500-kV	
Clearance	Min.	Avg.	Min.	Avg.	Min.	Avg.	Min.	Avg.
Peak field, kV/m	2.4	1.4	8.1	4.5	3.0	1.8	8.1	4.5
Edge of ROW, kV/m	0.3	0.3	2.5	2.6	1.3	1.1	2.5	2.6



**Table 4: Calculated magnetic fields for configurations of the proposed Santiam - Bethel/Santiam - Chemawa 230-kV line operated at maximum current.** Configurations are described in Tables 1 and 2.

a) **Configuration I: Santiam - Bethel/Santiam - Chemawa 230-kV line only**

Configuration	Proposed I		Existing	
ROW width, ft. (m)	125 (38)		125 (38)	
Line	Santiam - Bethel/Santiam - Chemawa 230-kV		Santiam - Chemawa 230-kV	
Clearance	Min.	Avg.	Min.	Avg.
Peak field, mG	87	50	218	139
Edge of ROW, mG	26	24	78	62

b) **Configuration II: Santiam - Bethel/Santiam - Chemawa 230-kV and Marion - Santiam 500-kV No. 1 and No. 2 lines**

Configuration	Proposed II				Existing			
ROW width, ft. (m)	270 (82)				270 (82)			
Line	Santiam - Bethel/ Santiam - Chemawa 230-kV		Marion - Santiam No. 1 and No. 2 500-kV		Santiam - Chemawa 230-kV		Marion - Santiam No. 1 and No. 2 500-kV	
Clearance	Min.	Avg.	Min.	Avg.	Min.	Avg.	Min.	Avg.
Peak field, mG	94	58	130	67	211	135	108	57
Edge of ROW, kV/m	29	24	52	39	80	65	50	38

**Table 5: States with transmission-line field limits**

STATE AGENCY	WITHIN RIGHT-OF-WAY	AT EDGE OF RIGHT-OF-WAY	COMMENTS
<b>a. 60-Hz ELECTRIC FIELD LIMIT, kV/m</b>			
Florida Department of Environmental Regulation	8 ( 230 kV) 10 (500 kV)	2	Codified regulation, adopted after a public rulemaking hearing in 1989.
Minnesota Environmental Quality Board	8	–	12-kV/m limit on the High-Voltage Direct Current (HVDC) nominal electric field.
Montana Board of Natural Resources and Conservation	7 <sup>1</sup>	1 <sup>2</sup>	Codified regulation, adopted after a public rulemaking hearing in 1984.
New Jersey Department of Environmental Protection	–	3	Used only as a guideline for evaluating complaints.
New York State Public Service Commission	11.8 (7,11) <sup>1</sup>	1.6	Explicitly implemented in terms of a specified right-of-way width.
Oregon Facility Siting Council	9	–	Codified regulation, adopted after a public rulemaking hearing in 1980.
<b>b. 60-Hz MAGNETIC FIELD LIMIT, mG</b>			
Florida Department of Environmental Regulation	–	150 ( 230 kV) 200 (500 kV)	Codified regulations, adopted after a public rulemaking hearing in 1989.
New York State Public Service Commission	–	200	Adopted August 29, 1990.

- 1 At road crossings
- 2 Landowner may waive limit

Sources: TDHS Report, 1989;TDHS Report, 1990

**Table 6: Common noise levels**

Sound Level, dBA	Noise Source or Effect
128	Threshold of pain
108	Rock-and-roll band
80	Truck at 50 ft. (15.2 m)
70	Gas lawnmower at 100 ft. (30 m)
60	Normal conversation indoors
50	Moderate rainfall on foliage
50	Edge of 500-kV right-of-way during rain
40	Refrigerator
25	Bedroom at night
0	Hearing threshold

Adapted from: USDOE, 1996.

**Table 7: Typical sound attenuation (in decibels) provided by buildings**

	Windows opened	Windows closed
<b>Warm climate</b>	12	24
<b>Cold climate</b>	17	24

Source: EPA, 1978.

**Table 8: Predicted foul-weather audible noise (AN) levels at edge of right-of-way (ROW) for proposed Santiam - Bethel/Santiam - Chemawa 230-kV line.** AN levels expressed in decibels on the A-weighted scale (dBA). L<sub>50</sub> and L<sub>5</sub> denote the levels exceeded 50 and 5 percent of the time, respectively. For the parallel-line configurations<sup>1</sup>, the AN level at the edge of the proposed Santiam - Bethel ROW is given first.

Configuration <sup>1</sup>	Foul-weather AN					
	Proposed			Existing		
	ROW ft. (m)	L <sub>50</sub> , dBA	L <sub>5</sub> , dBA	ROW ft. (m)	L <sub>50</sub> , dBA	L <sub>5</sub> , dBA
I	125 (38)	39	43	125 (38)	41	44
II	270 (82)	47, 52	51, 55	270 (82)	47, 52	51, 55

1 Configurations are described in Tables 1 and 2.

**Table 9: Predicted fair-weather radio interference (RI) levels at 100 feet (30.5 m) from the outside conductor of the proposed Santiam - Bethel/Santiam - Chemawa 230-kV line.** RI levels given in decibels above 1 microvolt/meter (dB $\mu$ V/m) at 1.0 MHz. L<sub>50</sub> denotes level exceeded 50 percent of the time. For the parallel-line configurations the RI level on the side of the proposed Santiam - Bethel ROW is given first.

Configuration <sup>1</sup>	Fair-weather RI	
	Proposed	Existing
	L <sub>50</sub> , dB $\mu$ V/m	L <sub>50</sub> , dB $\mu$ V/m
I	26	28
II	30, 41	30, 41

1 Configurations are described in Tables 1 and 2.

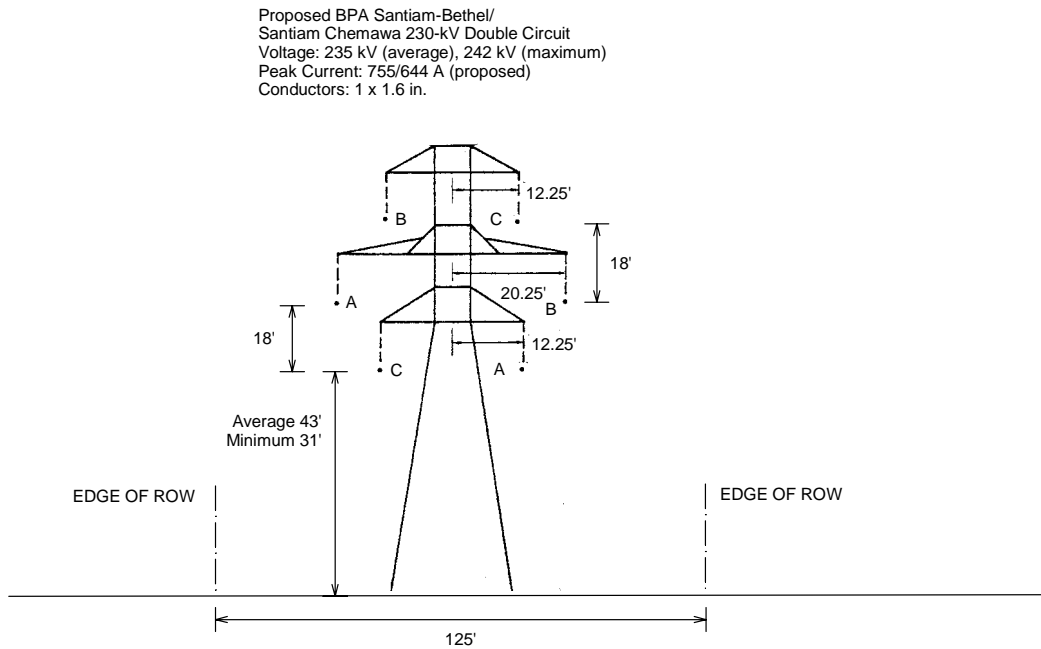
**Table 10: Predicted maximum foul-weather television interference (TVI) levels predicted at 100 feet (30.5 m) from the outside conductor of the proposed Santiam - Bethel/Santiam - Chemawa 230-kV line.** TVI levels given in decibels above 1 microvolt/meter (dB $\mu$ V/m) at 75 MHz. For the parallel-line configurations, the TVI level on the side of the proposed Santiam - Bethel ROW is given first.

<b>Configuration<sup>1</sup></b>	<b>Foul-weather TVI</b>	
	<b>Proposed</b>	<b>Existing</b>
	<b>L<sub>5</sub> (foul), dB<math>\mu</math>V/m</b>	<b>L<sub>5</sub> (foul), dB<math>\mu</math>V/m</b>
<b>I</b>	10	15
<b>II</b>	12, 27	15, 27

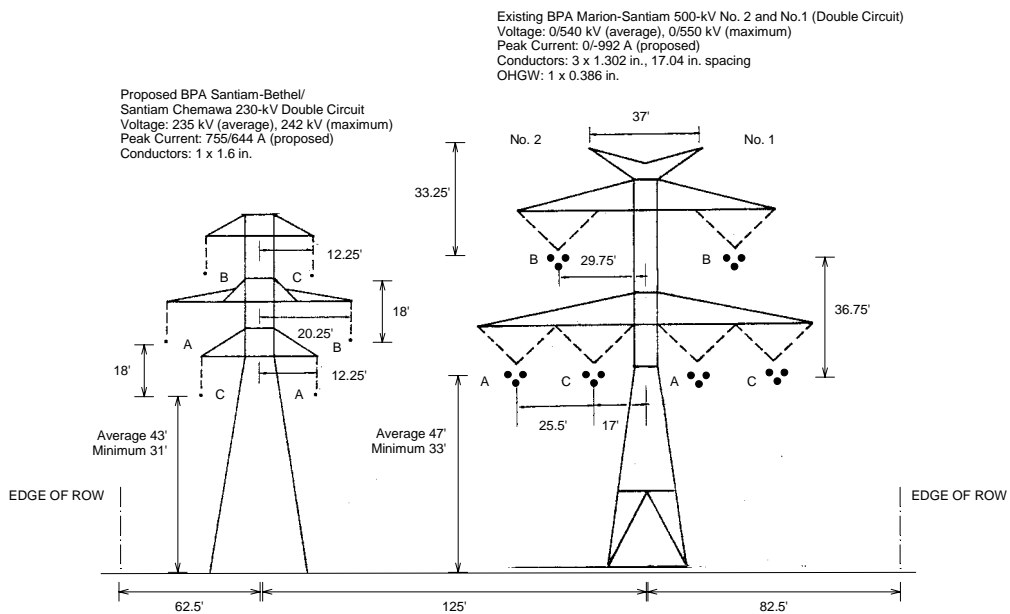
1 Configurations are described in detail in Tables 1 and 2.

**Figure 1: Configurations for proposed Santiam - Bethel/Santiam - Chemawa 230-kV line: a) proposed line with no parallel lines ( Configuration I); and b) proposed line with parallel 500-kV line (Configuration II).**

a) Proposed line with no parallel lines (Configuration I) (not to scale)

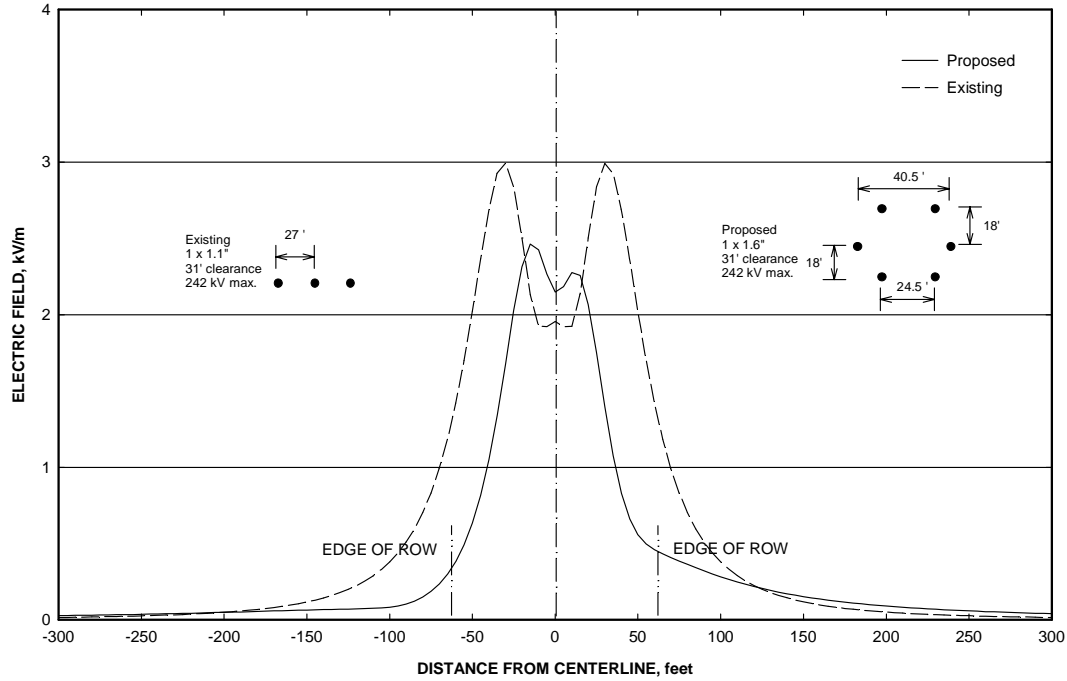


b) Proposed line with parallel 500-kV line (Configuration II) (not to scale)

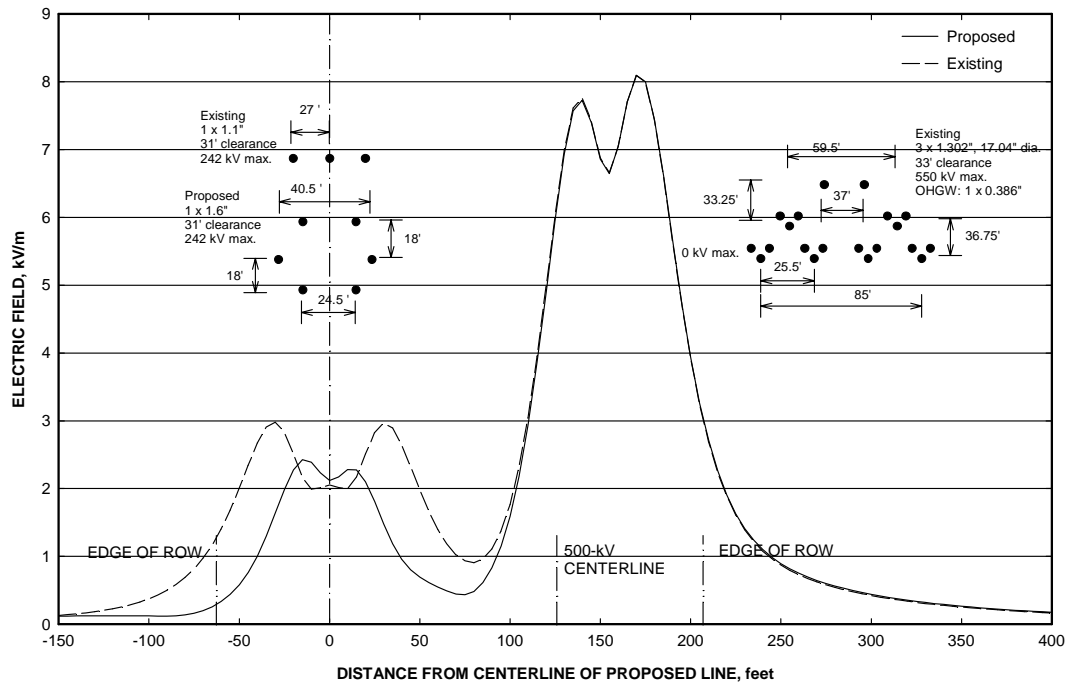


**Figure 2: Electric-field profiles for configurations of proposed Santiam - Bethel/Santiam - Chemawa 230-kV line: a) proposed line with no parallel line (Configuration I); and b) proposed line with parallel 500-kV line (Configuration II). Fields for maximum voltage and minimum clearances are shown.**

a) Proposed line with no parallel line (Configuration I).

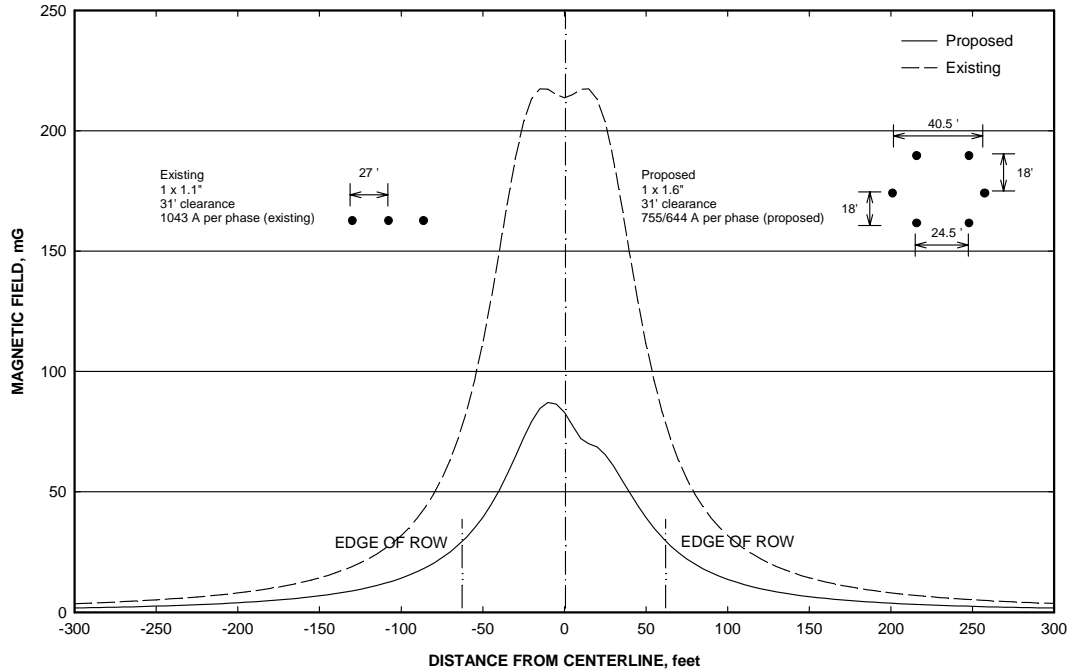


b) Proposed line with parallel 500-kV line (Configuration II)

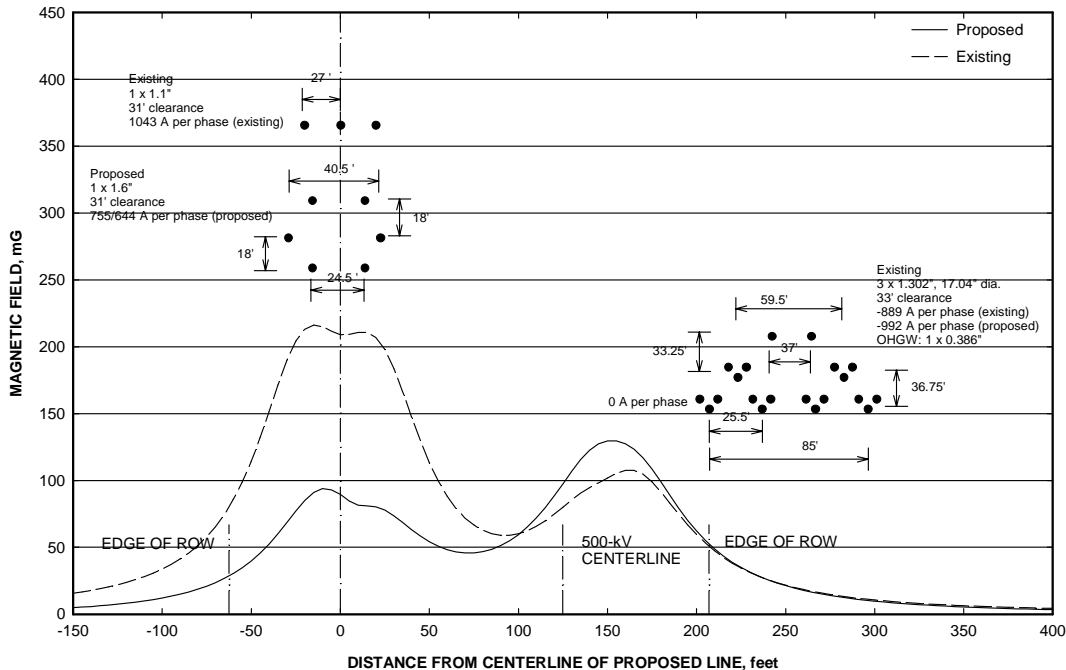


**Figure 3: Magnetic-field profiles for configurations of the proposed Santiam - Bethel/Santiam - Chemawa 230-kV line for maximum current conditions: a) proposed line with no parallel line (Configuration I); and b) proposed line with parallel 500-kV line (Configuration II).**

a) Proposed line with no parallel line (Configuration I)



b) Proposed line with parallel 500-kV line (Configuration II).





**SANTIAM-BETHEL TRANSMISSION PROJECT**

**APPENDIX B:**

**ASSESSMENT OF RESEARCH REGARDING EMF AND  
HEALTH AND ENVIRONMENTAL EFFECTS**

June 2001

Prepared by

**Exponent™**

and

**T. Dan Bracken, Inc.**

for

**Bonneville Power Administration**



## **Table of Contents**

1.0	Introduction .....	1
2.0	Health .....	1
2.1	The NIEHS Report and Research Program.....	1
2.2	Update of Research Related to Cancer.....	2
2.2.1	Epidemiology Studies of Children .....	2
2.2.2	Epidemiology Studies of Adults .....	5
2.2.3	Laboratory Studies of EMF.....	6
2.2.4	Summary Regarding Cancer .....	7
2.3	Research Related to Reproduction .....	7
2.4	Other Recent Reviews by Scientific Advisory Groups .....	7
2.4.1	National Radiological Protection Board of Great Britain (NRPB) Advisory Group on Non-Ionising Radiation .....	8
2.4.2	Health Council of the Netherlands.....	8
2.4.3	Institution of Electrical Engineers (IEE) of Great Britain.....	9
3.0	Ecological Research.....	9
3.1	Fauna.....	9
3.2	Flora .....	11
3.3	Summary .....	11
	LIST OF REFERENCES .....	12
	LIST OF PREPARERS .....	17



# **APPENDIX B: ASSESSMENT OF RESEARCH REGARDING EMF AND HEALTH AND ENVIRONMENTAL EFFECTS**

## **1.0 Introduction**

Over the last 20 years, research has been conducted in the United States (U.S.) and around the world to examine whether exposures to electric and magnetic fields (EMF) at 50/60 hertz (Hz) from electric power lines are a cause of cancer, or adversely affect human health. The research included epidemiology studies that suggested a link with childhood for some types of exposures, as well as other epidemiology studies that did not; it also included lifetime animal studies, which showed no evidence of adverse health effects. Comprehensive reviews of the research conducted by governmental and scientific agencies in the U.S. and in the United Kingdom (UK) had examined the research, and did not find a basis for imposing additional restrictions (NIEHS, 1999; IEE, 2000).

The Bonneville Power Administration (BPA) requested that Exponent update the BPA on research on EMF and health and in relation to exposures that might occur near the Bethel-Santiam Transmission Project.

This update concentrates on recent major research studies to explain how they contribute to the assessment of effects of EMF on health (Section 2). The focus is on both epidemiologic and laboratory research, because these research approaches provide different and complementary information for determining whether an environmental exposure can affect human health. Section 3, Ecological Research, reviews studies of potential effects of EMF on plants and animals in the natural environment. No additional studies of environmental effects were found in our search of the scientific literature through May 2001.

## **2.0 Health**

### **2.1 The NIEHS Report and Research Program**

In 1998, the NIEHS completed a comprehensive review of the scientific research on health effects of EMF. The NIEHS had been managing a research program that Congress funded in 1996, in response to questions regarding exposure to EMF from power sources. The program was known as the RAPID Program (Research and Public Information Dissemination Program). The NIEHS convened a panel of scientists (the “Working Group”) to review and evaluate the RAPID Program research and other research. Their report, *Assessment of Health Effects from Exposure to Power-Line Frequency Electric and Magnetic Fields*, was completed in July 1998 (NIEHS, 1998).

The director of the NIEHS prepared a health risk assessment of EMF and submitted his report to Congress in June 1999 (NIEHS, 1999). Experts at NIEHS, who had considered the previous Working Group report, reports from four technical workshops, and research that became available after June 1998, concluded as follows:

The scientific evidence suggesting that ELF-EMF [extremely low frequency-electric and magnetic field] exposures pose any health risk is weak. The strongest evidence for health

effects comes from associations observed in human populations with two forms of cancer: childhood leukemia and chronic lymphocytic leukemia in occupationally exposed adults. . . . In contrast, the mechanistic studies and animal toxicology literature fail to demonstrate any consistent pattern . . . . No indication of increased leukemias in experimental animals has been observed. . . . The lack of consistent, positive findings in animal or mechanistic studies weakens the belief that this association is actually due to ELF-EMF, but it cannot completely discount the epidemiology findings. . . . The NIEHS does not believe that other cancers or other non-cancer health outcomes provide sufficient evidence of a risk to currently warrant concern (pp. 9-10).

Although the results of the RAPID research are described in some detail in the 1998 report, many of the studies had not been published in the peer-reviewed literature. Recognizing the need to have these results reviewed and considered for publication, the NIEHS arranged for a special edition of the journal *Radiation Research* (*Radiation Research*, 153(5), 2000) to be devoted to this topic.<sup>1</sup>

## **2.2 Update of Research Related to Cancer**

This update includes studies of residential or occupational exposures to EMF and leukemia that became available this year (2001), including several reports from the California Department of Health Services. That Department conducted a workshop in 1999 to discuss epidemiologic research on EMF and health. The reports presented at this workshop were published in January 2001 as a supplement to the journal, *Bioelectromagnetics*. Many of the papers were technical discussions of methodology issues in epidemiologic studies of EMF, including discussions of how better to understand the conflicting results reported in previous studies (Neutra and Del Pizzo, 2001). For example, one paper evaluated epidemiology studies to determine whether systematic errors occurred in selection of cases and controls, or measurement of exposure. Although such systematic errors, or bias, occurred in some studies, there was insufficient information to assess the effect on results (Wartenberg, 2001a). Other researchers discuss epidemiologic approaches to study how possible confounding factors, such as the age and type of home and traffic density, might affect the interpretation of studies of EMF and childhood cancer (Langholz, 2001; Reynolds et al., 2001).

For this update, we review papers from this workshop that provide new information or statistical analyses. Several of the studies are “meta-analyses,” an approach that incorporates statistical methods to analyze differences and aggregate the results of smaller studies. The section below includes a review of meta-analyses of the studies of childhood leukemia through 1999, and a meta-analysis of studies of breast cancer in adults (Erren, 2001).

### **2.2.1 Epidemiology Studies of Children**

The question of power lines and childhood cancer has been based on the assumption that the relevant exposure associated with power lines is the magnetic field, rather than the electric field. This assumption rests on the fact that electric fields are shielded from the interior of homes (where people spend the vast majority of their time) by walls and vegetation, while magnetic fields are not. The magnetic field in the vicinity of a power line results from the flow of current; higher currents result in higher levels of magnetic fields.

---

<sup>1</sup> See, for instance, the articles cited in the **List of References** under Balcer- Kubiczek, Boorman, Loberg, and Ryan.

Epidemiologic studies report results in the form of statistical associations. The term “statistical association” is used to describe the tendency of two things to be linked or to vary in the same way, such as level of exposure and occurrence of disease. However, statistical associations are not automatically an indication of cause and effect, because the interpretation of numerical information depends on the context, including (for example) the nature of what is being studied, the source of the data, how the data were collected, and the size of the study. The larger studies and more powerful studies of EMF have not reported convincing statistical associations between power lines and childhood leukemia (e.g., Linet et al., 1997; McBride et al., 1999; UKCCS, 1999). Despite the larger sample size, these studies usually had a limited number of cases exposed over 2 or 3 milligauss (mG).

### *Epidemiology studies*

The following discussion briefly describes major studies.

- A study from Germany included 502 children with leukemia and 1,289 control children (Schuz et al., 2001). Measurements of magnetic-field intensity (50 Hz) were taken for 24 hours in the child’s bedroom. The results were calculated for daytime or nighttime levels in the bedroom, rather than for the child’s overall 24-hour exposure. The authors report an association with leukemia for mean daytime magnetic-field exposures that might have been due to chance. They reported an association between mean nighttime magnetic-field levels and leukemia for the highest exposed group (4 mG or higher; 9 cases). The assessment of exposure by mean field levels in the bedroom did not link magnetic-field levels to any specific source. The authors note in their conclusions that “. . . fewer than one-third of all stronger magnetic fields were caused by high-voltage powerlines. . . .” (Schuz et al., 2001: 734).

Several aspects of the study detract from the validity of the results: the estimate included a broad margin of error because only a small number of cases was exposed at the higher levels, and many eligible cases and controls did not participate, which means that the responders may not represent the population and results could be biased. Another concern is that these magnetic field measurements were taken in 1997, long after the relevant exposure period for cases diagnosed in 1990-1994. Magnetic-field levels may have changed over time, as electricity usage changed.

- A study from British Columbia, Canada, included 462 children who had been diagnosed with leukemia and an equal number of children without leukemia for comparison (McBride et al., 1999). Magnetic-field exposure was assessed for each of the children in several ways: personal monitors were worn in a backpack for 48 hours, a monitor took measurements in the bedroom for 24 hours, the wiring outside the house was rated by potential exposure level (wire codes), and measurements were taken around the outside perimeter of the homes. (Wire codes are a method of estimating relative exposure intensity based on the configuration of the power lines.) Regardless of the method used to estimate magnetic-field exposure, the magnetic-field exposure of children who had leukemia was not greater than that of the children in the comparison group.
- A study conducted in Ontario, Canada reported on the magnetic-field exposure of a smaller group of children (Green et al., 1999a). No increased risk estimates were found with the average magnetic fields in the bedroom or the interior, or with any of the three methods of estimating exposure from wire-configuration codes. A still smaller group of 88 children with leukemia and their controls wore personal monitors to measure magnetic fields (Green et al., 1999b). Associations with magnetic fields were reported in some of the analyses, but most of the risk estimates had a broad margin of error, and major methodological problems in the study preclude any clear interpretation of the findings.

- The United Kingdom Childhood Cancer Study, the largest study to date, included a total of 1073 childhood leukemia cases (UKCCS, 1999). Exposure was assessed by spot measurements in the home (bedroom and family room) and school, and summarized by averaging these over time. No evidence was found to support the idea of an increased risk of leukemia from exposures to magnetic fields from power sources inside or outside of the home.
- The UKCCS investigators had obtained magnetic-field measurements on only a portion of the cases in their study (UKCCS, 1999). To obtain additional information, they used a method to assess exposure to magnetic fields without entering homes; they were thus able to analyze 50% more subjects (UKCCS, 2000). For all these children, they measured distances to power lines and substations. This information was used to calculate the magnetic field from these external field sources, based on power-line characteristics related to production of magnetic fields. The results of the second UKCCS study showed no evidence for an association with leukemia for magnetic fields calculated to be between 1 mG and 2 mG, 2 mG and 4 mG, or 4 mG or greater at the residence, in contrast to the weak association reported for measured fields of 4 mG or greater in the first report (UKCCS, 1999).

Researchers have proposed that the associations that are sometimes reported between childhood leukemia and power lines may be due to other factors that can confound the analysis. One example is heavy traffic, which may occur near power lines and can increase the levels of potentially carcinogenic chemicals in the area. Earlier studies had reported associations between traffic density and childhood cancer (Savitz et al., 1988). If power lines were more common in areas that had higher traffic density, then the increased air pollution might explain an association between power lines and childhood cancer. However, more recent studies seem to eliminate this possibility. In a study of 90 cases of childhood leukemia, Reynolds et al. (2001) found no evidence of an association with traffic density. In a larger study that included 986 cases of childhood leukemia, no association was found with high traffic-density exposure during pregnancy or childhood (Raaschou-Nielsen et al., 2001). In addition, no association with childhood leukemia or brain cancer was found for exposures to benzene or nitrogen dioxide. Associations were reported between Hodgkin's disease and exposure to each of these chemicals.

#### *Meta-analyses of studies of leukemia*

Recently, researchers reanalyzed the data from previous epidemiology studies of magnetic fields and childhood leukemia (Ahlbom et al., 2000; Greenland et al., 2000). The researchers pooled the data on individuals from each of the studies, creating a study with a larger number of subjects and therefore greater statistical power than any single study. A pooled analysis is preferable to other types of meta-analyses in which the results from several studies are combined from grouped data obtained from the published studies. These analyses focused on studies that assessed exposure to magnetic fields using 24-hour measurements or calculations based on the characteristics of the power lines and current load. Both Ahlbom et al. and Greenland et al. used exposure categories of <0.1 microtesla ( $\mu\text{T}$ ) (<1 mG) as a reference category. The statistical results of these analyses can be summarized as follows:

- The pooled analyses provided no indication that wire codes are more strongly associated with leukemia than measured fields.
- Pooling these data corroborates an absence of an association between childhood leukemia and magnetic fields for exposures below 0.3  $\mu\text{T}$  (3 mG).
- Pooling these data results in a statistical association with leukemia for exposures greater than 0.3 or 0.4  $\mu\text{T}$  (3-4 mG).



The authors are appropriately cautious in the interpretation of their analyses, and they clearly identify the limitations in their evaluation of the original studies. Magnetic fields above 0.3  $\mu$ T in residences are estimated to be rather rare, about 3% in the U.S. (Zaffanella, 1993). Limitations include sparse data (few cases) to adequately characterize a relationship between magnetic fields and leukemia, uncertainties related to pooling different magnetic-field measures without evidence that all of the measures are comparable, and incomplete and limited data on important confounders (other risk factors for disease that may distort the analysis) such as housing type and traffic density.

A meta-analysis of the data from epidemiologic studies of childhood leukemia studies was presented at the California Workshop and recently published (Wartenberg, 2001b). This meta-analysis did not have the advantage of obtaining and pooling the data on all of the individuals in the studies, unlike those published before it (Ahlbom et al., 2000; Greenland et al., 2000). Rather than individual data, Wartenberg (2001b) used an approach that extracted the published results, reported as grouped data from several published studies. He used 19 studies overall, after excluding 7 studies that had insufficient data on individuals or deficiencies in the exposure assessment data. He reported a weak association for a) “proximity to electrical facilities” based on wire codes or distance, and b) magnetic-field level over 2 mG, based on either calculations from wiring and loading characteristics (if available) or on spot magnetic-field measurements. The results show more cases than controls exposed to measured or calculated fields above 2 mG. The author concludes that the analysis supports an association, although the size of the effect is small to moderate, but also notes “limitations due to design, confounding, and other biases may suggest alternative interpretations” (Wartenberg, 2001b:S-100).

The results of this meta-analysis are not directly comparable to previous ones regarding fields of 3 or 4 mG because the analysis was not based on individual data. The comparison of grouped data used different exposure cut points for the analysis and different criteria for the comparison group. None of these three analyses (Ahlbom et al., 2000; Greenland et al., 2000; Wartenberg, 2001b) includes the results of the UK analysis of over 3000 cases based on calculated fields, which found no association between EMF and childhood cancer, regardless of the exposure level.

### **2.2.2 Epidemiology Studies of Adults**

Studies of adults with certain types of cancer, such as brain cancer, breast cancer, or leukemia, have reported associations with exposure to magnetic fields at residences, but results have not been consistent across studies. Contradictory results among studies argue against a conclusion that the association reflects a cause-and-effect relationship. In their assessments of risk, scientists give most weight to studies that include more people, obtain more detailed and individual exposure assessments, and/or include people who have higher exposures.

A study of 492 adult cases of brain cancer in California included measurements of magnetic fields taken in the home and at the front door, and considered the types of power-line wiring (Wrensch et al., 1999). The authors report no evidence of increased risk with higher exposures, no association with type of power line, and no link with levels measured at the front door.

A number of recent studies of breast cancer focused on electric blankets as a source of high exposure. Electric blankets are assumed to be one of the strongest sources of EMF exposure in the home. Three studies of electric blanket use found no evidence that long-term use increased the risk of breast cancer. Women who developed breast cancer reported no difference in total use of electric blankets, use in recent years, or use many years in the past:

- Gammon et al. (1998) reported that, even for those who kept the blanket on most of the time, no increase in risk was found for those who had longer duration of use (measured in months).

- A study of 608 breast cancer cases also found no evidence of increased use of electric blankets or other home appliances in cases compared to controls, and no indication of increasing risk with a longer time of use (Zheng et al., 2000).
- In a cohort of over 120,000 female nurses, data were obtained on known risk factors for breast cancer as well as electric-blanket use (Laden et al., 2000). For a large subset of this group, the questions about exposure were asked before the disease occurred, a step taken to eliminate bias in recalling exposure.

Erren (2001) reported the results of a meta-analysis of the studies of breast cancer, in which the results of 24 different studies in women were statistically aggregated. When the results of all 24 studies were pooled, including studies of workplace exposures, the estimate indicated an association between EMF and a small excess breast cancer risk. The pooled results for exposure to EMF in the vicinity of electrical facilities did not show an association with breast cancer, nor did the results for exposure to EMF from appliance use. However, the meta-analysis also showed a lack of consistency among the results of the individual studies, a broad variation in the designs, and a wide range of methods used to assess exposure. No adjustments were made to the data to give increased weight to studies based on more comprehensive exposure assessments. The author also noted that the weak statistical association might be an artifact (a result of chance or unforeseen error) rather than an indication of a cause-and-effect relationship (Erren, 2001).

### **2.2.3 Laboratory Studies of EMF**

Laboratory studies complement epidemiologic studies of people because the effects of heredity, diet, and other health-related exposures of animals can be better controlled or eliminated. The assessment of EMF and health, as for any other exposure, includes chronic, long-term studies in animals (*in vivo* studies) and studies of changes in genes or other cellular processes observed in isolated cells and tissues in the laboratory (*in vitro*).

Although the results of the RAPID Program were described in some detail in the NIEHS reports (NIEHS, 1998), many of the studies had not been published in the peer-reviewed literature. The RAPID research program included studies of four biological effects, each of which had been observed in only one laboratory. These effects are as follows: effects on gene expression, increased intracellular calcium in a human cell line, proliferation of cell colonies on agar, and increased activity of the enzyme ornithine decarboxylase (ODC). Some scientists have suggested that these biological responses are signs of possible adverse health effects of EMF. It is standard scientific procedure to attempt to replicate results in other laboratories, because artifacts and investigator error can occur in scientific investigations. Replications, often using more experiments or more rigorous protocols, help to ensure objectivity and validity. Attempts at replication can substantiate and strengthen an observation, or they may discover the underlying reason for the observed response.

Studies in the RAPID program reported no consistent biological effects of EMF exposure on gene expression, intracellular calcium concentration, growth of cell colonies on agar, or ODC activity (Boorman et al., 2000b). For example, Loberg et al. (2000) and Balcer-Kubiczek et al. (2000) studied the expression of hundreds of cancer-related genes in human mammary or leukemia cell lines. They found no increase in gene expression with increased intensity of magnetic fields. To test the experimental procedure, they used X-rays and treatments known to affect the genes. These are known as positive controls and, as expected, caused gene expression in exposed cells.

Scientists have concluded that the combined animal bioassay results provide no evidence that magnetic fields cause, enhance, or promote the development of leukemia and lymphoma, or mammary cancer (e.g., Boorman et al., 1999; McCormick et al., 1999; Boorman et al., 2000 a, b; Anderson et al., 2001).

#### **2.2.4 Summary Regarding Cancer**

Epidemiology studies do not support the idea that EMF from power lines increase the risk of cancers in adults. The latest epidemiologic studies of childhood cancer, considered in the context of the other data, provide no persuasive and consistent evidence that leukemia in children is causally associated with magnetic fields measured at the home, calculated based on distance and current loading, or with wire codes. Recent meta-analyses reported no association between childhood cancer and magnetic fields below 2 or 3 mG. Although some association was reported for fields above this level, fields at most residences are likely to be below 3 or 4 mG. The authors of each of these analyses list several biases and problems that render the data inconclusive, and prevent resolution of the inconsistencies in the epidemiologic data. For this reason, laboratory studies can provide important complementary information. Large, well-conducted animal studies provide no convincing evidence that exposure increases the risk of cancer. Animal studies, and studies of initiation and promotion, provide no basis to conclude that EMF increases leukemia, lymphoma, breast, brain, or any other type of cancer.

#### **2.3 Research Related to Reproduction**

Previous epidemiologic studies reported no association with birth weight or fetal growth retardation after exposure to sources of relatively strong magnetic fields, such as electric blankets, or sources of typically weaker magnetic fields such as power lines (Bracken et al., 1995; Belanger et al., 1998).

A recent epidemiology study examined miscarriages<sup>2</sup> in relation to exposures to magnetic fields from electric bed-heating (electric blankets, heated waterbeds and mattress pads), which result in higher exposures than residential fields in general (Lee et al., 2000). The researchers assessed exposure prior to the birth (a prospective study) and included information to control for potential confounding factors (other exposures and conditions that affect the risk of miscarriage). This study had a large number of cases and high participation rates. Miscarriage rates were lower among users of electric bed heating.

Studies of laboratory animals exposed to pure 60-Hz fields have shown no increase in birth defects, no multigenerational effects, and no changes that would indicate an increase in miscarriage or loss of fertility (e.g., Ryan et al., 1999; Ryan et al., 2000). Exposed and unexposed litters were no different in the amount of fetal loss and the number and type of birth defects, indicating no reproductive effect of EMF.

In summary, the recent evidence from epidemiology and laboratory studies provides no indication that exposure to power-frequency EMF has an adverse effect on reproduction, pregnancy, or growth and development of the embryo. The results of these recent studies are consistent with the conclusions of the NIEHS.

#### **2.4 Other Recent Reviews by Scientific Advisory Groups**

Reviews of the scientific research regarding EMF and health by Health Council of the Netherlands and the Institute of Electrical Engineers of the UK were published in 2000. The National Radiological

---

<sup>2</sup> The medical term for miscarriage is spontaneous abortion.

Protection Board of Great Britain (NRPB) Advisory Group on Non-Ionizing Radiation published the most recent review in 2001. This review includes research published in 2000, and includes the most comprehensive discussion of the individual research studies.

#### **2.4.1 National Radiological Protection Board of Great Britain (NRPB) Advisory Group on Non-Ionising Radiation**

The conclusions from the report prepared by the NRPB's Advisory Group on Non-Ionising Radiation (AGNIR) on extremely low frequency (ELF) EMF and the risk of cancer are consistent with previous reviews. Members from universities, medical schools, and cancer research institutes reviewed the reports of experimental and epidemiological studies, including reports in the literature in 2000. Their general conclusions are as follows:

Laboratory experiments have provided no good evidence that extremely low frequency electromagnetic fields are capable of producing cancer, nor do human epidemiological studies suggest that they cause cancer in general. There is, however, some epidemiological evidence that prolonged exposure to higher levels of power frequency magnetic fields is associated with a small risk of leukaemia in children. In practice, such levels of exposure are seldom encountered by the general public in the UK [or in the US] (NRPB, 2001: 164).

The group further recognizes that the scientific evidence suggesting that exposure to power-frequency electromagnetic fields poses an increased risk of cancer is very weak. Virtually all of the cellular, animal, and human laboratory evidence provides no support for an increased risk of cancer incidence following such exposure to power frequencies, although sporadic positive findings have been reported. In addition, the epidemiological evidence is, at best, weak.

These conclusions of the Advisory Group are consistent with previous reviews by the NIEHS (1999) and the Health Council of the Netherlands (HCN, 2000). The NRPB response to the Advisory Group report states "the review of experimental studies by [the Advisory Group] AGNIR gives no clear support for a causal relationship between exposure to ELF-EMFs and cancer" (NRPB, 2001:1).

#### **2.4.2 Health Council of the Netherlands**

The Health Council of the Netherlands has prepared an update of its 1992 Advisory Report on exposure to electromagnetic fields (0 Hz to 10 MHz) (HCN, 2000). Members of the Expert Committee prepared the report. The Expert Committee based its analysis on the review and summaries of the studies provided in the NIEHS (1998) and concurred with the views of the director of the NIEHS (1999). For the update, the Committee evaluated a number of publications that appeared after these reports, e.g., McBride et al. (1999) and Green et al. (1999a), and wrote:

The committee thinks that the quality of the relevant epidemiological research has improved considerably since the publication of the advisory report in 1992. Even so, this research has not resulted in unequivocal, scientifically reliable conclusions (p. 15).

The Council emphasizes that the associations with EMF reported in epidemiologic studies are strictly statistical and do not demonstrate a cause-and-effect relationship. In their view, experimental research does not demonstrate a causal link or a mechanism to explain EMF as a cause of disease in humans. They concluded that there is no reason to recommend measures to limit residence near overhead power lines (HCN, 2000).

### **2.4.3 Institution of Electrical Engineers (IEE) of Great Britain**

One of the recent reviews was that of the Institution of Electrical Engineers (IEE) of Great Britain (IEE, 2000). In 1992, the IEE set up a Working Party whose eight members, with broad expertise in the health sciences, review the relevant scientific literature and prepare reports of their views. Their conclusion is based on recent major epidemiologic studies and the scientific literature built up over the past 20 years. In May 2000, the Working Party concluded “. . . that there is still not convincing scientific evidence showing harmful effects of low level electromagnetic fields on humans” (IEE, 2000:1).

## **3.0 Ecological Research**

Scientists have studied the effects of high-voltage transmission lines on many plant and animal species in the natural environment. In this section, we briefly review the research on the effects of EMF on ecological systems to assess the likelihood of adverse impacts. In addition to the comprehensive review of research on this topic by wildlife biologists at the BPA (Lee et al., 1996), we searched the published scientific literature for more recent studies published between 1995 and May 2001.

### **3.1 Fauna**

The habitat on the transmission-line right-of-way and surrounding area shields most wildlife from electric fields. Vegetation in the form of grasses, shrubs, and small trees largely shields small ground-dwelling species such as mice, rabbits, foxes, and snakes from electric fields. Species that live underground, such as moles, woodchucks, and worms, are further shielded from electric fields by the soil. Hence, large species such as deer and domestic livestock (e.g., sheep and cattle) have greater potential exposures to electric fields since they can stand taller than surrounding vegetation. However, the duration of exposure for deer and other large animals is likely to be limited to foraging bouts or the time it takes them to cross under the line. Furthermore, all species would be exposed to higher magnetic fields under a transmission-line than elsewhere, as the vegetation and soil do not provide shielding from this aspect of the transmission-line electrical environment.

Field studies have been performed in which the behavior of large mammals in the vicinity of high-voltage transmission lines was monitored. No effects of electric or magnetic fields were evident in two studies from the northern United States on big game species, such as deer and elk, exposed to a 500-kV transmission line (Goodwin 1975; Picton et al., 1985). In such studies, a possible confounding factor is audible noise. Audible noise associated with high-voltage power transmission lines (with voltages greater than 110-kV) is due to corona. Audible noise generated by transmission lines reaches its highest levels in inclement weather (rain or snow).

Much larger populations of animals that might spend time near a transmission line are livestock that graze under or near transmission lines. To provide a more sensitive and reliable test for adverse effects than informal observation, scientists have studied animals continuously exposed to fields from the lines in relatively controlled conditions. For example, grazing animals such as cows and sheep have been exposed to high-voltage transmission lines and their reproductive performance examined (Lee et al., 1996). In some studies, the effects of exposure over one or more successive breedings were examined (Angell et al., 1990). Compared to unexposed animals in a similar environment, it was found that the exposure did not affect reproductive functions or pregnancy of cows (Algers and Hennichs, 1985; Algers and Hultgren, 1987).

A group of investigators from Oregon State University, Portland State University, and other academic centers evaluated the effects of long-term exposure to EMF from a 500-kV transmission line operated by

BPA on various cellular aspects of immune response, including the production of proteins by leukocytes (IL-1 and IL-2) of sheep. In previous unpublished reports, the researchers found differences in IL-1 activity between exposed and control groups. However, in their most recent replication, the authors found no evidence of differences in these measures of immune function. The sheep were exposed to 27 months of continuous exposure to EMF, a period of exposure much greater than the short, intermittent exposures of sheep grazing under transmission lines. Mean exposures of magnetic and electric fields were 3.5-3.8  $\mu$ T (35-38 mG) and 5.2-5.8 kV/m, respectively (Hefeneider et al., 2001).

Scientists from Illinois Institute of Technology (IIT) monitored the possible effects of electric and magnetic fields on fauna and flora in Michigan and Wisconsin from 1969 – 1997 to evaluate the effects of an above-ground, military-communications antenna operating at 76 Hz. The antenna produces EMF similar in physical characteristics to those produced by high-voltage transmission lines, but of much lower intensity. This study included embryonic development, fertility, postnatal growth, maturation, aerobic metabolism, and homing behavior, and showed no adverse impacts of ELF electric and magnetic fields on the animals (NRC, 1997).

The hormone melatonin, secreted at night by the pineal gland, plays a role in animals that are seasonal breeders. Studies in laboratory mice and rats have suggested that exposure to electric and/or magnetic fields might affect levels of the hormone melatonin, but results have not been consistent (Wilson et al., 1981; Holmberg, 1995; Kroeker et al., 1996; Vollrath et al., 1997; Huuskonen et al., 2001). However, when researchers examined sheep and cattle exposed to EMF from transmission lines exceeding 500-kV, they found no effect on the levels of the hormone melatonin in blood, weight gain, onset of puberty, or behavior in sheep and cattle (Stormshak et al., 1992; Lee et al., 1993; Lee et al., 1995; Thompson et al., 1995; Burchard et al., 1998).

Another part of the IIT study examined the effect of the antenna system fields on the growth, development, and homing behavior of birds. Studies of embryonic development (Beaver et al., 1993), fertility, postnatal growth, maturation, aerobic metabolism, and homing behavior showed no adverse impacts of ELF electric and magnetic fields on the animals (NRC, 1997). Fernie and colleagues studied the effects of continuous EMF exposure of raptors to an electric field of 10 kV/m in a controlled, laboratory setting. The exposure was designed to mimic exposure to a 765-kV transmission line. Continuous EMF exposure was found to reduce hatching success, yet increase egg size, fledging success, and embryonic development (Fernie et al., 2000). In a study of the effects on body mass and food intake of reproducing falcons, the authors found that EMF lengthened the photoperiod as a result of altered melatonin levels in the male species, yet concluded that “EMF effects on adult birds may only occur after continuous, extended exposure,” which is not likely to occur from resting on power lines (Fernie and Bird, 1999:620).

Several avian species are reported to use the earth’s magnetic field as one of the cues for navigation. It has been proposed that deposits of magnetite in specialized cells in the head are the mechanism by which the birds can detect variations in the inclination and intensity of a dc magnetic field (Kirschvink and Gould, 1981; Walcott et al., 1988). In early studies of transmission lines, it was reported that the migratory patterns of birds appeared to be altered near transmission lines (Southern, 1975; Larkin and Sutherland, 1977). However, these studies were of crude design, and Lee et al. (1996) concluded that, “During migration, birds must routinely fly over probably hundreds (or thousands) of electrical transmission and distribution lines. We are not aware of any evidence to suggest that such lines are disrupting migratory flights” (p. 4-59). No further studies on this topic were identified in the literature.

Bees, like birds, are able to detect the earth’s dc magnetic fields. They are known to use magnetite particles, which are contained in an abdominal organ, as a compass (Kirschvink and Gould, 1981). In the

laboratory, they are able to discriminate between a localized magnetic anomaly and a uniform background dc magnetic field (Walker et al., 1982; Kirschvink et al., 1992).

Greenberg et al. (1981) studied honeybee colonies placed near 765-kV transmission lines. They found that hives exposed to electric fields of 7 kV/m had decreased hive weight, abnormal amounts of propolis (a resinous material) at hive entrances, increased mortality and irritability, loss of the queen in some hives, and a decrease in the hive's overall survival compared to hives that were not exposed. Exposure to electric fields of 7-12 kV/m may induce a current or heat the interior of the hive; however, placing the hive farther from the line, shielding the hive, or using hives without metallic parts eliminates this problem. ITT studied the effects of EMF on bees exposed to the 76-Hz antenna system at lower intensities and concluded that these behavioral effects of "ELF-EMF impacts are absent or at most minimal" (NRC, 1997:102).

Reptiles and amphibians contribute to the overall functioning of the forest ecosystems. However, little research has been performed on the effects of EMF on reptiles and amphibians in their natural habitat.

### **3.2 Flora**

Numerous studies have been carried out to assess the effect of exposure of plants to transmission-line electric and magnetic fields. These studies have involved both forest species and agriculture crops. Researchers have found no adverse effects on plant responses, including seed germination, seedling emergence, seedling growth, leaf area per plant, flowering, seed production, germination of the seeds, longevity, and biomass production (Lee et al., 1996).

The only confirmed adverse effect of transmission lines on plants was reported for transmission lines with voltages above 1200-kV. For example, Douglas Fir trees planted within 15 m of the conductors were shorter than trees planted away from the line. Shorter trees are believed to result from corona-induced damage to the branch tips. Trees between 15 and 30 m away from the line suffered needle burns, but those 30 m and beyond were not affected (Rogers et al., 1984). These effects would not occur at the lower field intensities expected beyond the right-of-way of the proposed 500-kV transmission line.

### **3.3 Summary**

The habitat on the transmission-line rights-of-way and surrounding areas shield smaller animals from electric fields produced by high-voltage transmission lines; thus, vegetation easily shields small animals from electric fields. The greatest potential for larger animals to be exposed to EMF occurs when they are passing beneath the lines. Studies of animal reproductive performance, behavior, melatonin production, immune function, and navigation have found minimal or no effects of EMF. Past studies have found little effect of EMF on plants; no recent studies of plants growing near transmission lines have been performed. In summary, the literature published to date has shown little evidence of adverse effects of EMF from high-voltage transmission lines on wildlife and plants. At the field intensities associated with the proposed 230-kV transmission line, no adverse effects on wildlife or plants are expected.

## **LIST OF REFERENCES**

- Ahlbom, A.; Day, N.; Feychting, M.; Roman, E.; Skinner, J.; Dockerty, J.; Linet, M.; Michealis, J.; Olsen, J.H.; Tynes, T.; Verasalo, P.K. 2000. A pooled analysis of magnetic fields and childhood leukaemia. *British Journal of Cancer*, 83(5): 692-698.
- Algers, B.; and Hennichs, K. 1985. The effect of exposure to 400-kV transmission lines on the fertility of cows: a retrospective cohort study. *Preventive Veterinary Medicine* 3: 351-361.
- Algers, B.; and Hultgren, J. 1987. Effects of long-term exposure to a 400-kV, 50-Hz transmission line on estrous and fertility in cows. *Preventive Veterinary Medicine* 5: 21-36.
- Anderson, L.E.; Morris, J.E.; Miller, D.L.; Rafferty, C.N.; Ebi, K.L.; Sasser, L.B. 2001. Large granular lymphocytic (LGL) leukemia in rats exposed to intermittent 60 Hz magnetic fields. *Bioelectromagnetics*, 22:185-193.
- Angell, R.F.; Schott, M.R.; Raleigh, R.J.; Bracken, T.D. 1990. Effects of a high-voltage direct-current transmission line on beef cattle production. *Bioelectromagnetics*. 11(4):273-82.
- Balcer-Kubiczek, E.K.; Harrison, G.H.; Davis, C.C.; Haas, M.L.; Koffman, B.H. 2000. Expression analysis of human HL60 exposed to 60 Hz square or sine-wave magnetic fields. *Radiation Research*, 153(5): 670-678.
- Beaver, D.L.; Hill, R.W.; Lederle, P.E. 1993. Assessment of the effects of extremely low frequency electromagnetic radiation on growth and maturation in nestling tree swallows and deer mice. *Electricity and Magnetism in Biology and Medicine*. M. Blank, ed., San Francisco Press, Inc., pp. 925-926.
- Belanger, K.; Leaderer, B.; Hellenbrand, K.; Holford, T.R.; McSharry, J.; Power, M.E.; Bracken, M.B. 1998. Spontaneous abortion and exposure to electric blankets and heated water beds. *Epidemiology*, 9:36-42.
- Boorman, G.A.; Anderson, L.E.; Morris, J.E.; Sasser, L.B.; Mann, P.C.; Grumbein, S.L.; Hailey, J.R.; McNally, A.; Sills, R.C.; Haseman, J.K. 1999. Effects of 26-week magnetic field exposure in a DMBA initiation-promotion mammary glands model in Sprague-Dawley rats. *Carcinogenesis*, 20: 899-904.
- Boorman, G.A.; McCormick, D.J.; Ward, J.M.; Haseman, J.K.; Sills, R.C. 2000a. Magnetic fields and mammary cancer in rodents: A critical review and evaluation of published literature. *Radiation Research*, 153(5), Part 2: 617.
- Boorman, G.A.; Rafferty, C.N.; Ward, J.M.; Sills, R.C. 2000b. Leukemia and lymphoma incidence in rodents exposed to low-frequency magnetic fields. *Radiation Research*, 153(5), Part 2: 627.
- Bracken, M.B.; Belanger, K.; Hellenbrand, K.; Dlugosz, L.; Holford, T.R.; McSharry, J.E.; Adesso, K.; Leaderer, B. 1995. Exposure to electromagnetic fields during pregnancy with emphasis on electrically heated beds: association with birth weight and intrauterine growth retardation. *Epidemiology*, 6(3): 263-270.



- Burchard, J.F.; Nguyen, D.H.; Block, E. 1998. Effects of electric and magnetic fields on nocturnal melatonin concentrations in dairy cows. *J Dairy Sci.* 81(3):722-7.
- Erren, T.C. 2001. A meta-analysis of epidemiological studies of electric magnetic fields and breast cancer in women and men. *Bioelectromagnetics Supplement*, 5: S105-S119.
- Fernie, K.J.; and Bird, D.M. 1999. Effects of electromagnetic fields on body mass and food-intake of American kestrels. *The Condor.* 101:616-621.
- Fernie, K.J.; Bird, D.M.; Dawson, R.D.; Lague, P.C. 2000. Effects of electromagnetic fields on the reproductive success of American kestrels. *Physiol Biochem Zool.* 73(1):60-5.
- Gammon, M.D.; Schoenberg, J.B.; Britton, J.A.; Kelsey, J.L.; Stanford, J.L.; Malone, K.E.; Coates, R.J.; Brogan, D.J.; Potischman, N.; Swanson, C.A.; Brinton, L.A. 1998. Electric blanket use and breast cancer risk among younger women. *American Journal of Epidemiology*, 148: 556-63.
- Goodwin Jr., J.G. 1975. Big game movement near a 500-kV transmission line in northern Idaho. Bonneville Power Administration, Engineering and Construction Division, Portland, OR, June 27.
- Green, L.M.; Miller, A.B.; Villeneuve, P.J.; Agnew, D.A.; Greenberg, M.L.; Li, J.H.; Donnelly, K.E. 1999a. A case control study of childhood leukemia in southern Ontario, Canada, and exposure to magnetic fields in residences. *International Journal of Cancer*, 82:161-170.
- Green, L.M.; Miller, A.B.; Agnew, D.A.; Greenberg, M.L.; Li, J.H.; Villeneuve, P.J.; Tibshirani, R. 1999b. Childhood leukemia and personal monitoring of residential exposures to electric and magnetic fields in Ontario, Canada. *Cancer Causes and Control*, 10: 233-243.
- Greenberg, B.; Bindokas, V.P.; Frazier, M.J.; Gauger, J.R. 1981. Response of honey bees, *apis mellifera* L., to high-voltage transmission lines. *Environmental Entomology*, 10: 600-610.
- Greenland, S.; Sheppard, A.; Kelsh, M.; Kuane, W.; Poole, C.; Kelsh, M.A. 2000. Childhood leukemia and power frequency magnetic fields: analysis from pooled data of thirteen epidemiologic studies. *Epidemiology*, 11: 624-634.
- HCN (Health Council of the Netherlands). 2000. Report on Exposure to Electromagnetic Fields (0 Hz – 10 MHz). No. 2000/06E.
- Hefeneider, S.H.; McCoy, S.L.; Hausman, F.A.; Christensen, H.L.; Takahashi, D.; Perrin, N.; Bracken, T.D.; Shin, K.Y.; Hall, A.S. 2001. Long-term effects of 60-Hz electric vs. magnetic fields on IL-1 and IL-2 activity in sheep. *Bioelectromagnetics*, 22(3):170-177.
- Holmberg, B. 1995. Magnetic fields and cancer: animal and cellular evidence—an overview. *Environ Health Perspect.* 103 Suppl 2:63-7.
- Huuskonen, H.; Saastamoinen, V.; Komulainen, H.; Laitinen, J.; Juutilainen, J. 2001. Effects of low-frequency magnetic fields on implantation in rats. *Reprod Toxicol*, 15(1):49-59.
- IEE (Institution of Electrical Engineers), Biological Effects Working Party. May 2000. The possible harmful biological effects of low level electromagnetic fields of frequencies up to 300 GHz. IEE Position Statement.

- Kirschvink, J.L.; and Gould, J.L. 1981. Biogenic magnetite as a basis for magnetic field detection in animals. *Biosystems*, 13(3):181-201.
- Kirschvink, J.L.; Diaz Ricci, J.; Nesson, M.H.; Kirschvink, S.J. 1992. Magnetite-based magnetoreceptors in animals: structural, behavioral, and biophysical studies. Electric Power Research Institute (EPRI), Report No. TR-102008, Palo Alto, CA. September.
- Kroeker, G.; Parkinson, D.; Vriend, J.; Peeling, J. 1996. Neurochemical effects of static magnetic field exposure. *Surg Neurol*, 45(1):62-6.
- Laden, F.; Neas, L.M.; Tolbert, P.E.; Holmes, M.D.; Hankinson, S.E.; Spiegelman, D.; Speizer, F.E.; Hunter, D.J. 2000. Electric blanket use and breast cancer in the nurses' health study. *American Journal of Epidemiology*, 152(1): 41-49.
- Langholz, B. 2001. Factors that explain the power line configuration wiring code - childhood leukemia association: what would they look like? *Bioelectromagnetics Supplements*, 5: S19-S31.
- Larkin, R.P., and Sutherland, P.J. 1977. Migrating birds respond to Project Seafarer's electromagnetic field. *Science*, 195(4280): 777-9 1977, Feb 25.
- Lee, G.M.; Neutra, R.R.; Hristova, L.; Yost, M.; Hiatt, R.A. 2000. The use of electric bed heaters and the risk of clinically recognized spontaneous abortion. *Epidemiology*, 11: 406-415.
- Lee, J., Stormshak, F., Thompson, J., Thinesen, P., Painter, L., Olenchek, B., Hess, D., Forbes, R. 1993. Melatonin secretion and puberty in female lambs exposed to environmental electric and magnetic fields. *Biol Reprod* 49(4):857-64
- Lee, J.M. BPA Biological Studies Task Team. 1996. Electrical and biological effects of transmission lines: a review. Bonneville Power Administration, Portland, Oregon, December.
- Lee, J.M., Stormshak, F., Thompson, J., Hess, D.L., Foster, D.L. 1995. Melatonin and puberty in female lambs exposed to EMF: a replicate study. *Bioelectromagnetics*, 16(2):119-23
- Linnet, M.S.; Hatch E.H.; Kleinerman, R.A.; Robinson, L.L.; Kaune, W.T.; Friedman, D.R.; Seversch, R.K.; Haines, C.M.; Hartsock, C.T.; Niwa, S.; Wacholder, S.; Tarone, R.E. 1997. Residential exposure to magnetic fields and acute lymphoblastic leukemia in children. *New England Journal of Medicine*, 337: 1-7.
- Loberg, L.I.; Engdahl, W.R.; Gauger, J.R.; McCormick, D.L. 2000. Expression of cancer-related genes in human cells exposed to 60 Hz magnetic fields. *Radiation Research*, 153(5): 679-684.
- McBride, M.L.; and Gallagher, RP; Theriault, G; Armstrong, BG; Tamaro, S; Spinelli, JJ; Deadman, JE; Fincham, S; Robinson, D; Choi, W. 1999. Power-frequency electric and magnetic fields and risk of childhood leukemia in Canada. *American Journal of Epidemiology*, 149:831-842.
- McCormick, D.L.; Boorman, G.A.; Findlay, J.C.; Hailey, J.R.; Johnson, T.R.; Gauger, J.R.; Pletcher, J.M.; Sill, R.C.; Haseman, J.K. 1999. Chronic toxicity/oncogenicity evaluation of 60 Hz (power frequency) magnetic fields in B6C3F mice. *Toxicologic Pathology*, 27:279-285.

- Neutra, R.R., and Del Pizzo, V. 2001. A richer conceptualization of "exposure" for epidemiological studies of the "EMF mixture". *Bioelectromagnetics Supplements*, 5: S48-S57.
- NIEHS (National Institute of Environmental Health Sciences). 1998. Assessment of Health Effects from Exposure to Power-Line Frequency Electric and Magnetic Fields: Working Group Report. NIH Publication No. 98-3981. Research Triangle Park, NC: National Institute of Environmental Health Sciences of the U.S. National Institutes of Health.
- NIEHS (National Institute of Environmental Health). 1999. Health effects from exposure to power line frequency electric and magnetic fields. NIH; National Institute of Health; NIH No. 99-4493; Research Triangle Park, NC.
- NRC (National Research Council). 1997. An evaluation of the U.S. Navy's extremely low frequency communications system ecological monitoring program. National Academy Press, Washington, D.C.
- NRPB (National Radiological Protection Board). 2001. Response statement of the NRPB: ELF electromagnetic fields and the risk of cancer. National Radiological Protection Board, Chilton, Didcot, Oxon, Volume 12, No.1, ISBN 0-859951-456-0.
- Picton, H.D., Canfield, J.E., Nelson, G.P. 1985. The impact of a 500-kV transmission line upon the North Boulder Winter Elk Range. US Forest Service Contract 53-0398-30E-3.
- Raaschou-Nielsen, O.; Hertel, O.; Thomsen, B.L.; Olsen, J.H. 2001. Air pollution from traffic at the residence of children with cancer. *American Journal of Epidemiology*, 153(5): 433-43.
- Radiation Research*. 2000. (Special Edition Updating RAPID results.) 153(5): 637-641. *See entries under Balcer-Kubiczek, Boorman, Loberg, and Ryan.*
- Reynolds, P.; Elkin, E.; Scalf, R.; Von Behren, J.; Neutra, R.R. 2001. A case-control pilot study of traffic exposures and early childhood leukemia using a geographic information system. *Bioelectromagnetics Supplements*, 5:S58-S6.
- Rogers, L.E., Beedlow, P.A., Carlile, D.W., Ganok, K.A., Lee, J.M. 1984. Environmental studies of a 1100-kV prototype transmission line: an annual report for the 1984 study period. Prepared by Battelle Pacific Northwest Laboratories for Bonneville Power Administration, Portland, Oregon.
- Ryan, B.M.; Symanski, R.R.; Pomeranz, L.E.; Johnson, T.R.; Gauger, J.R.; McCormick, D.L. 1999. Multi-generation reproduction toxicity assessment of 60-Hz magnetic fields using a continuous breeding protocol in rats. *Teratology*, 59(3): 156-62.
- Ryan, B.M.; Polen, M.; Gauger, J.R.; Mallett, E.; Kerns, M.B.; Bryan, T.L.; McCormick, D.L. 2000. Evaluation of the developmental toxicity in Sprague-Dawley rats. *Radiation Research*, 153(5): 637-641.
- Savitz, D.A., Wachtel, H., Barnes, F.A., John, E.M. & Tvrdik, J.G. 1988. Case-control study of childhood cancer and exposure to 60 Hz magnetic fields. *American Journal of Epidemiology*, 128, 21-38.
- Schuz, J.; Grigat, J.P.; Brinkmann, K.; Michaelis, J. 2001. Residential magnetic fields as a risk factor for childhood acute leukaemia: results from a German population-based case-control study. *International Journal of Cancer*, 91(5): 728-735. January 2.

- Southern, W.E. 1975. Orientation of gull chicks exposed to project Sanguine's electromagnetic field. *Science*, 189: 143-144.
- Stormshak, F., Bracken, T.D., Carey, M., Chartier, V., Dickson, L., Forbes, R., Hall, A., Havens, P., Hess, D., Krippaehne, S., Lee, J., Ogden, B., Olenchek, B., Painter, L., Rowe, K., Stearns, R., Thinesen, P., Thompson, J. 1992. Joint HVAC transmission EMF environmental study: final report on experiment 1. Bonneville Power Administration, Contract # DE-B179-90BPO4293, Portland, OR, May.
- Thompson, J.M.; Stormshak, F.; Lee, J.M.; Hess, D.; Painter, L. 1995. Cortisol secretion and growth in ewe lambs chronically exposed to electric and magnetic fields of a 60-Hertz 500-kilovolt AC transmission line. *J Animal Sci*, 73(11):3274-80
- UKCCS (United Kingdom Childhood Cancer Study Investigators). 1999. Exposure to power frequency magnetic fields and the risk of childhood cancer. *The Lancet*, 353(9194): 1925-31.
- UKCCS (United Kingdom Childhood Cancer Study Investigators). 2000. Childhood cancer and residential proximity to power lines. *British Journal of Cancer*, 83:1573-80.
- Vollrath, L.; Spessert, R.; Kratzsch, T.; Keiner, M.; Hollmann H. 1997. No short-term effects of high-frequency electromagnetic fields on the mammalian pineal gland. *Bioelectromagnetics*, 18(5):376-87.
- Walcott, C.; Gould, J.L.; Lednor, A.J. 1988. Homing of magnetized and demagnetized pigeons. *J Exp Biol*, 134:27-41.
- Walker, C.E.; Seitelman, D.L.; McElhaney, J.H.; Mullen, S.P.; Hagadorn, B.; Seto, Y.J. 1982. Effects of high-intensity 60-Hz fields on bone growth. *Journal of Bioelectricity*, 1(3):339-349.
- Wartenberg, D. 2001a. The potential impact of bias in studies of residential exposure to magnetic fields and childhood leukemia. *Bioelectromagnetics Supplements*, 5: S32-S47.
- Wartenberg, D. 2001b. Residential EMF exposure and childhood leukemia: Meta-analysis and population attributable risk. *Bioelectromagnetics Supplements*, 5: S86-S104.
- Wilson, B.W.; Anderson, L.E.; Hilton, D.I.; Phillips, RD. 1981. Chronic exposure to 60-Hz electric fields: effects on pineal function in the rat. *Bioelectromagnetics*, 2(4):371-80.
- Wrensch, M.; Yost, M.; Miike, R.; Lee, G.; Touchstone, J. 1999. Adult glioma in relation to residential power frequency electromagnetic field exposures in the San Francisco Bay Area. *Epidemiology*, 10: 523-527.
- Zaffanella, L.E. 1993. Survey of residential magnetic field sources. Vol. 1: Goals, results, and conclusions. (EPRI TR-102759-V1, Project 3335-02). Electric Power Research Institute, Palo Alto, CA.
- Zheng, T.Z.; Holford, T.R.; Mayne, S.T.; Owens, P.H.; Zhang, B.; Boyle, P.; Carter, D.; Ward, Y.W.; Zahm, S.H. 2000. Exposure to electromagnetic fields from use of electric blankets and other in-home electrical appliances and breast cancer risk. *American Journal of Epidemiology*, 151(11): 1103-11.

## LIST OF PREPARERS

**Linda S. Erdreich, Ph.D.**, is a Managing Scientist in the Health Group at Exponent. She received her Ph.D. in Epidemiology and an M.S. in Biostatistics and Epidemiology from The University of Oklahoma Health Sciences Center. Dr. Erdreich is an epidemiologist with specific expertise in biological and health research related to non-ionizing radiation, both radiofrequency and power-frequency fields. Formerly, she was Acting Section Chief and Group Leader of the Methods Evaluation and Development Staff at the U.S. Environmental Protection Agency (EPA) and Senior Epidemiologist of the Environmental Criteria and Assessment Office at the EPA. While at the EPA, she developed methods in quantitative health risk assessment, coordinated the drafting of federal guidelines, and participated in science policy decisions. Both in government and private industry, she has provided rigorous evaluations of the impact on public health or occupational health of a variety of chemicals, therapeutic drugs, and physical agents, including electric and magnetic fields. As a member of the Institute of Electrical and Electronics Engineers (IEEE) Standards Coordinating Committees on Non-Ionizing Radiation, Dr. Erdreich is chairman of a working group to evaluate epidemiologic data on radiofrequency exposures (3 kHz–300 Ghz). She has been appointed as a member of the Committee on Man and Radiation (COMAR) of the IEEE's *Engineering in Biology and Medicine Society*. Dr. Erdreich serves as Adjunct Associate Professor at the University of Medicine & Dentistry of New Jersey.

**William H. Bailey, Ph.D.**, is a Principal Scientist and manages the Health Group scientists in Exponent's New York office. Before joining Exponent, Dr. Bailey was President of Bailey Research Associates, Inc., the oldest research and consulting firm with specialized expertise in electro-magnetic fields and health. Dr. Bailey specializes in applying state-of-the-art assessment methods to environmental health and impact issues. His 30 years of training and experience include laboratory and epidemiologic research, health risk assessment, and comprehensive exposure analysis. Dr. Bailey is particularly well known for his research on potential health effects of electromagnetic fields and is active in setting IEEE standards for human exposure to electromagnetic fields. He uses advanced analytical and statistical methods in the design and analysis of both experimental studies and epidemiology and survey research studies. In addition, Dr. Bailey's postgraduate training in the social, economic, and behavioral sciences is helpful in assessing the important effects of social, economic, and community factors on health risks and vulnerability to environmental impacts in health and environmental justice research. He is a member of a working group that advises a committee of the World Health Organization on risk assessment, perception, and communication. Dr. Bailey is also a visiting scientist at the Cornell University Medical College. He was formerly Head of the Laboratory of Neuropharmacology and Environmental Toxicology at the New York State Institute for Basic Research, Staten Island, New York, and an Assistant Professor and NIH postdoctoral fellow in Neurochemistry at The Rockefeller University in New York.

**Maria DeJoseph, M.S.**, is an Epidemiologist in Exponent's Health Group and is based in New York, New York. Ms. DeJoseph has a background in epidemiology and biological sciences. She served as the primary investigator for a case-control epidemiologic study of her design to investigate a mediastinitis outbreak in cardiothoracic surgery patients. Ms. De Joseph also has recruited and interviewed subjects, and analyzed hormone levels for an epidemiologic breast cancer study. She has conducted phytochemical analyses of medicinal plants, including the isolation and fractionation of tropical plants used medicinally by indigenous peoples and primates of Central and South America. Ms. DeJoseph has served as an ethnobotanical and zoopharmacological field researcher in Mexico, Costa Rica and Venezuela. She has used a variety of methods to identify chemical and prospective pharmaceutical compounds, including HPLC, column chromatography, anti-microbial assays, gas chromatography mass spectrometry (GC-MS), and nuclear magnetic resonance spectroscopy (NMR). Before joining exponent, Ms. DeJoseph was a Research Assistant in the Medical School, Division of Epidemiology at Stanford University.

*This page intentionally left blank.*

## 5.0 Persons and Agencies Consulted

### 5.1 Federal Agencies

- United States Fish and Wildlife Service
- National Marine Fisheries Service
- United States Army Corps of Engineers

### 5.2 State Agencies

- Oregon State Office of Archaeology and Historic Preservation
- Oregon Department of Fish and Wildlife
- Oregon Department of Environmental Quality
- Oregon Division of State Lands
- Oregon Department of Land Conservation and State Lands
- Energy Facility Siting Council, Oregon Department of Energy
- Oregon Department of Transportation

### 5.3 Local Agencies

- Linn County Planning and Building Department
- Marion County Planning and Building Department
- Marion County Department of Community Development

### 5.4 Tribes

- Confederated Tribes of Grand Ronde

### 5.5 Utilities

- Portland General Electric

### 5.6 Landowners

There are approximately 100 landowners on the mailing list.





## 6.0 References

- Applied Archaeological Research. May 22, 2001. Results of a Cultural Resources Survey of the Bonneville Power Administration's Santiam-Bethel Tap Transmission Line Project, Marion County, Oregon. (Applied Archaeological Research Report No. 181) Portland, OR. Prepared for Bonneville Power Administration, Portland, OR.
- Bonneville Power Administration. 2000. Transmission system vegetation management program. Final environmental impact statement. DOE/EIS-0285. Portland, OR.
- Bracken, T. Dan. June 2001. Santiam-Bethel Transmission Project, *Appendix A, Electrical Effects*.
- Cowardin, L. M., V. Carter, F. C. Golet, and E. T. LaRoe. 1979. Classification of wetlands and deep water habitats of the United States. (FWS/OBS-79/31.) U.S. Fish and Wildlife Service. Washington, DC.
- Fennimore, Joe. June 8, 2001. Associate Planner, Marion County Community Development Department. Telephone conversation..
- Hopkins, S. Planner. May 1, 2001. Linn County Planning Department, OR. Telephone conversation.
- Hunt, W. April 30, 2001. Assistant district fish biologist. Oregon Department of Fish and Wildlife, Corvallis, OR. Telephone conversation.
- Jones & Stokes. May 17, 2001. Upgrade to the Bonneville Power Administration Santiam to Bethel, Oregon transmission line. Draft biological assessment. (J&S 0P008.01.) Bellevue, WA. Prepared for Bonneville Power Administration, Portland, OR.
- Linn County, Oregon. 2000. Linn County parks. Available: <<http://www.co.linn.or.us/>>. Accessed May 8, 2001.
- \_\_\_\_\_. 2001. Recreational facilities. Available: <<http://www.co.linn.or.us/>>. Accessed April 20, 2001.
- Marion County, Oregon. 2001. Recreational facilities. Available: <<http://www.co.marion.or.us>>. Accessed April 20, 2001.
- Maser, C. 1998. Mammals of the Pacific Northwest: from the coast to the high Cascades. Oregon State University Press. Corvallis, OR.
- McMaster, K. State Supervisor, USFWS Oregon State Office, Portland, OR. October 27, 2000 – letter to Leslie Kelleher of Bonneville Power Authority.
- Mitsch, W.J., and J.G. Gosselink. 1993. Wetlands. International Thomson Publishing. New York, NY.
- ODFW (Oregon Department of Fish and Wildlife). 1993. Oregon wildlife diversity plan. Portland, OR.

- ODFW. 1997. Oregon Department of Fish and Wildlife guidelines and criteria for stream-road crossings. Portland, OR.
- Oregon Department of Environmental Quality. 1998a. Map of 303(d) listed waterbodies and sub basin priorities. Available: <<http://waterquality.deq.state.or.us/WQLData/303dListMap.htm>>. Accessed April 26, 2001.
- Oregon Department of Environmental Quality. 1998b. Final 1998 303(d) file download page. Available: <<http://waterquality.deq.state.or.us/wq/303dlist/Download303d.htm>>. Accessed. April 26, 2001.
- Oregon Labor Market Information System. 2001. Oregon Employment Department unemployment and poverty statistics. Available: <<http://www.olmis.org>>. Accessed April 16, 2001.
- Oregon Natural Heritage Program. 2001. Natural Heritage database. Portland, OR.
- Oregon State University. 1997a. Oregon agriculture census, Linn County, 1997. Available: <<http://govinfo.library.orst.edu/cgi-bin/ag-list?01-043.orc>>. Accessed May 10, 2001.
- \_\_\_\_\_. 1997b. Oregon agriculture census, Linn County, 1997. Available: <<http://govinfo.library.orst.edu/cgi-bin/ag-list?28-043.orc>>. Accessed May 10, 2001.
- \_\_\_\_\_. 1997c. Oregon agriculture census, Marion County, 1997. Available: <<http://govinfo.library.orst.edu/cgi-bin/ag-list?01-047.orc>>. Accessed May 10, 2001.
- \_\_\_\_\_. 1997d. Oregon agriculture census, Marion County, 1997. Available: <<http://govinfo.library.orst.edu/cgi-bin/ag-list?28-047.orc>>. Accessed May 10, 2001.
- Oregon State University, Agricultural Extension. 1999. Oregon State University Extension agricultural statistics, Linn County, last updated April 23, 2001. Available: <<http://oregonstate.edu/extension/linn/Agstats1.html>>. Accessed May 10, 2001.
- Oregon State University, Extension Economic Information Office. 1999. Marion County agricultural commodity sales, 1999 (preliminary), last updated April 18, 2000. Available: <<http://www.open.org/~mcboc/agsales.htm>>. Accessed May 10, 2001.
- Portland State University Population Research Center. 2000. Population, ethnic, gender, and age distribution. Available: <<http://www.upa.pdx.edu/CPRC/>>. Accessed April 11, 2001.
- Salem OnLine. 2000. Salem OnLine. Available: <<http://www.salemlodging.com/index.html>>. Accessed May 8, 2001.
- U.S. Bureau of the Census. 1997. 1997 Model-based income and unemployment estimates. Available: <<http://www.census.gov>>. Accessed April 10, 2001.
- \_\_\_\_\_. 2000. 1999 unemployment rates. Available: <<http://www.census.gov>>. Accessed April 10, 2001.
- U.S. Bureau of Economic Analysis. 1998. Regional accounts data, employment sectors, annual earnings by industry sector, income and unemployment. Available: <<http://www.bea.doc.gov/bea/regional/reis/ca05>>. Accessed April 18, 2001.

USFWS (U.S. Fish and Wildlife Service). 1986. Recovery plan for the Pacific bald eagle. USDI Fish and Wildlife Service, Portland, OR.

USGS. 2000a. Groundwater atlas of the United States: Idaho, Oregon, and Washington. HA730-H. Available: <[http://capp.water.usgs.gov/gwa/ch\\_h/jpeg/H083.jpeg](http://capp.water.usgs.gov/gwa/ch_h/jpeg/H083.jpeg)>. Accessed April 30, 2001.

\_\_\_\_\_. 2000b. 1990 water use. Available: <<http://water.usgs.gov>>. Accessed April 30, 2001.

Wheeldon, Robert. June 6, 2001. Associate Planner, Linn County Planning and Building Department. Telephone conversation.



## 7.0 Glossary and Acronyms

### Acronyms

A	Ampere
BPA	Bonneville Power Administration
CWA	Clean Water Act
DLC	Donation Land Claim
EFH	Essential Fish Habitat
EMF	Electric and magnetic fields
EMI	Electromagnetic Interference
EPA	Environmental Protection Agency
ESU	Evolutionarily Significant Unit
FAA	Federal Aviation Administration
FCC	Federal Communication Commission
FEMA	Federal Emergency Management Agency
NAS	National Academy of Sciences
NEPA	National Environmental Policy Act
NESC	National Electrical Safety Code
NIEHS	National Institute of Environmental Health Sciences
NPDES	National Pollutant Discharge Elimination System
NRC	National Research Council
NWI	National Wetland Inventory
ODFW	Oregon Department of Fish and Wildlife
PEM	Palustrine emergent
PGE	Portland General Electric
PFO	Palustrine forested
PSS	Palustrine scrub-shrub
RI	Radio Interference
ROW	Right-of-way

SWPP	Stormwater Pollution Prevention
TVI	Television Interference
USFWS	U.S. Fish and Wildlife Service
USGS	U.S. Geological Service

### **Technical Terms**

Anadromous	Refers to fish such as salmon that hatch and rear in fresh water, move to the ocean to mature, and then return to fresh water to reproduce.
Alluvium	Material such as sand, silt, or clay that has been deposited on land by running water of streams and rivers.
Arcing	The process of current flowing across a gap, such as fault current flowing across an insulator string that flashed over due to a lightening strike.
Biological Assessment	A document required by the Endangered Species Act, which requires an evaluation of potential effects on listed species and critical habitat prior to implementing a proposed action. A proposed action is defined as any activity authorized, funded or carried out by a federal agency.
Blackouts	The disconnection of the source of electricity from all the electrical loads in a certain geographical area. Brought about by an emergency forced outage or other fault in the generation, transmission or distribution system serving the area.
Capacity	A measure of the ability of the transmission line to carry electricity.
Circuit	A system of conductors through which an electric current is intended to flow.
Conductor	Any metallic material, usually in the form of wire, cable, or bar, suitable for carrying an electrical current.
Corona	The phenomenon whereby the electric field associated with a power line cause ionization (molecular breakdown) of surrounding air, thus creating a high-frequency noise. This noise can be heard as static over an automobile radio when travelling under the power line.
Danger tree	Trees that pose a danger or hazard to the transmission line.
Double-circuit line	To place two separate electrical circuits on the same transmission structures or poles. Each circuit contains three separate conductors or bundles of conductors.

Floodplain	That portion of a river valley adjacent to the stream channel which is covered with water when the stream overflows its banks during flood stage.
Lattice steel	Refers to transmission towers constructed of multiple steel members that are connected together (usually in triangular shapes) to make up a frame.
Load	The amount of electric energy delivered or required at any specific point or points on a system. Load originates primarily at the energy using equipment of consumers, such as heaters, air conditioners, lights and motors. At BPA, load includes delivery to direct service industries (Note: Load is slightly larger than metered energy because of normal transmission and distribution losses in delivery from generator to consumer). Because loads are used to determine resource requirements, forecasts of electricity use are converted to loads.
Median	The middle number in a given sequence of numbers.
Mitigation	Steps taken to remove or lessen the effects predicted for each resource, as potentially caused by the transmission project. They may include reducing the impact, compensating for the impact, or avoiding it entirely. Some measures, such as adjusting the location of the towers to avoid a particular resource, are taken during the study and location process. Others, such as reseeding access roads, and/or avoiding the proliferation of weeds, are taken following project completion.
National Electrical Safety Code (NESC)	Written standards for the design, construction, maintenance and operation of electric supply and communication lines, equipment, and supply station in order to safeguard persons from hazards associated with those activities.
National Environmental Policy Act (NEPA)	A 1969 federal law that required evaluation of the environmental impact of federally funded projects and programs.
Noxious weeds	Plants that are injurious to public health, crops, livestock, land, or other property.
Outage	An event, caused by a disturbance on the electrical system, that requires BPA to remove a piece of equipment or a section of line from service. The disturbance can be either natural or caused by humans.
Overload	When too much current flows through transmission facilities that could cause damage or overheating. In the event of overloading, equipment has safeguards to disconnect it from the flow of electricity.

Palustrine emergent wetland	A shallow freshwater wetland characterized by erect, rotted, herbaceous hydrophytes (water loving plants).
Palustrine forested wetland	A wetland characterized by woody vegetation that is 20 feet or more in height.
Palustrine scrub-shrub wetland	A wetland dominated by woody vegetation less than 20 feet tall. This vegetation includes true shrubs, young trees, and trees and shrubs that are small or stunted because of environmental conditions.
Peak load	The maximum electrical load or the maximum average load during a designated interval such as 15 minutes.
Per capita	Per person
Reliability	The measure of the ability of a power system to provide uninterrupted service, even while that system is under stress.
Right-of-way (ROW)	An easement for a certain purpose over the land of another, such as a strip of land, electric transmission line ditch or pipeline. BPA usually acquires easements for its transmission lines, roads and other facilities such as guys and anchors.
Single-circuit	One electrical circuit consisting of three separate conductors or three bundles of conductors.
Substation	A non-generating electrical power station that serves to transform voltages to higher or lower levels, and that serves as a delivery point to individual customers such as utilities or large industrial plants. The BPA system has more than 400 substations.
Tap	A short transmission line that connects a substation to an existing transmission line.
Transmission grid	An interconnected network of transmission lines and associated equipment for the bulk transfer of electric energy between points of supply and demand. The BPA transmission grid includes some 22,500 circuit kilometers (14,00 circuit miles) of lines connecting more than 400 substations in the Pacific Northwest. The main grid consists of 230-kV, 345-kV, and 500-kV transmission lines.
Transmission line	A high-voltage power line used to carry electric power efficiently over long distances.
Voltage	The driving force that cause a current to flow in an electric circuit. Voltage and volt are often used interchangeably.
Wetlands	An area where the soil experiences anaerobic conditions because of inundation of water during part of any given year. Indicators of a wetland include types of plants, soil characteristics and hydrology.





**SANTIAM - BETHEL TRANSMISSION PROJECT**

**APPENDIX A**  
**ELECTRICAL EFFECTS**

June 2001

Prepared by  
**T. Dan Bracken, Inc.**

for  
**Bonneville Power Administration**



## Table of Contents

<b>1.0</b>	<b>Introduction</b> .....	<b>1</b>
<b>2.0</b>	<b>Physical Description</b> .....	<b>3</b>
2.1	Proposed Line.....	3
2.2	Existing Lines.....	3
<b>3.0</b>	<b>Electric Field</b> .....	<b>3</b>
3.1	Basic Concepts.....	3
3.2	Transmission-line Electric Fields.....	4
3.3	Calculated Values of Electric Fields.....	5
3.4	Environmental Electric Fields.....	6
<b>4.0</b>	<b>Magnetic Field</b> .....	<b>7</b>
4.1	Basic Concepts.....	7
4.2	Transmission-line Magnetic Fields.....	8
4.3	Calculated Values for Magnetic Fields.....	9
4.4	Environmental Magnetic Fields.....	9
<b>5.0</b>	<b>Electric and Magnetic Field (EMF) Effects</b> .....	<b>12</b>
5.1	Electric Fields: Short-term Effects.....	12
5.2	Magnetic Field: Short-term Effects.....	15
<b>6.0</b>	<b>Regulations</b> .....	<b>16</b>
<b>7.0</b>	<b>Audible Noise</b> .....	<b>17</b>
7.1	Basic Concepts.....	17
7.2	Transmission-line Audible Noise.....	19
7.3	Predicted Audible Noise Levels.....	19
7.4	Discussion.....	20
7.5	Conclusion.....	20
<b>8.0</b>	<b>Electromagnetic Interference</b> .....	<b>20</b>
8.1	Basic Concepts.....	20
8.2	Radio Interference (RI).....	21
8.3	Predicted RI Levels.....	21
8.4	Television Interference (TVI).....	22
8.5	Predicted TVI Levels.....	22
8.6	Interference with Other Devices.....	22
8.7	Conclusion.....	22
<b>9.0</b>	<b>Other Corona Effects</b> .....	<b>23</b>
<b>10.0</b>	<b>Summary</b> .....	<b>23</b>
	<b>List of References Cited</b> .....	<b>25</b>
	<b>List of Preparers</b> .....	<b>29</b>

## List of Tables

Table 1:	Physical and electrical characteristics of Santiam - Bethel Project corridors.....	31
Table 2:	Possible corridors for Santiam - Bethel Project .....	31
Table 3:	Calculated electric fields for configurations of the proposed Santiam - Bethel/ Santiam-Chemawa 230-kV line operated at maximum voltage .....	32
Table 4	Calculated magnetic fields for configurations of the proposed Santiam – Bethel/ Santiam - Chemawa 230-kV line operated at maximum current .....	33
Table 5	States with transmission-line field limits .....	34
Table 6	Common noise levels .....	35
Table 7	Typical sound attenuation (in decibels) provided by buildings .....	35
Table 8	Predicted foul-weather audible noise (AN) levels at edge of right-of-way (ROW) for proposed Santiam – Bethel/Santiam - Chemawa 230-kV line .....	36
Table 9	Predicted fair-weather radio interference (RI) levels at 100 feet (30.5 m) from the outside conductor of the proposed Santiam – Bethel/Santiam - Chemawa 230-kV line.....	36
Table 10	Predicted maximum foul-weather television interference (TVI) levels predicted at 100 feet (30.5 m) from the outside conductor of the proposed Santiam – Bethel/Santiam - Chemawa 230-kV line.....	37

## List of Figures

Figure 1	Configurations for proposed Santiam – Bethel/ Santiam- Chemawa 230-kV line: a) proposed line with no parallel lines (Configuration I); and b) proposed line with parallel 500-kV line (Configuration II).....	38
Figure 2	Electric-field profiles for configurations of proposed Santiam – Bethel/Santiam - Chemawa 230-kV line: a) proposed line with no parallel line (Configuration I); and b) proposed line with parallel 500-kV line (Configuration II) .....	39
Figure 3	Magnetic-field profiles for selected configurations of the proposed Santiam - Bethel/ Santiam – Chemawa 230-kV line for maximum current conditions: a) proposed line with no parallel line (Configuration I); and b) proposed line with parallel 500-kV line (Configuration II).....	40

# ELECTRICAL EFFECTS FROM THE PROPOSED SANTIAM - BETHEL TRANSMISSION PROJECT

## 1.0 Introduction

The Bonneville Power Administration (BPA) is proposing to build a 16.7-mile (mi.) (26.9-kilometer [km]) 230-kilovolt (kV) transmission line from the Santiam Substation near Stayton, Oregon, to a tap point on the existing PGE 230-kV Bethel line near Salem, Oregon. The proposed Santiam - Bethel Transmission Project would replace 16.7 mi. (26.9 km) of the single-circuit Santiam - Chemawa 230-kV line with a double-circuit 230-kV line. The proposed double-circuit line would consist of the new Santiam - Bethel 230-kV line and the rebuilt Santiam - Chemawa 230-kV line. Configurations along the existing line route include the right-of-way with no parallel lines (15.2 mi. or 24.5 km) and the right-of-way parallel to an existing 500-kV line (1.5 mi. or 2.4 km). The purpose of this report is to describe and quantify the electrical effects of the proposed Santiam - Bethel Transmission Project. These include the following:

- the levels of 60-hertz (Hz; cycles per second) electric and magnetic fields (EMF) at 3.28 feet (ft.) or 1 meter (m) above the ground,
- the effects associated with those fields,
- the levels of audible noise produced by the line, and
- electromagnetic interference associated with the line.

Electrical effects occur near all transmission lines, including those already present along the proposed route for the Santiam - Bethel line. Therefore, the levels of these quantities for the proposed line are computed and compared with those from the existing lines along the route.

The voltage on the conductors of transmission lines generates an electric field in the space between the conductors and the ground. The electric field is calculated or measured in units of volts-per-meter (V/m) or kilovolts-per-meter (kV/m) at a height of 3.28 ft. (1 m) above the ground. The current flowing in the conductors of the transmission line generates a magnetic field in the air and earth near the transmission line; current is expressed in units of amperes (A). The magnetic field is expressed in milligauss (mG), and is usually measured or calculated at a height of 3.28 ft. (1 m) above the ground. The electric field at the surface of the conductors causes the phenomenon of corona. Corona is the electrical breakdown or ionization of air in very strong electric fields, and is the source of audible noise, electromagnetic radiation, and visible light.

To quantify EMF levels along the route, the electric and magnetic fields from the proposed and existing lines were calculated using the BPA Corona and Field Effects Program (USDOE, undated). In this program, the calculation of 60-Hz fields uses standard superposition techniques for vector fields from several line sources: in this case, the line sources are transmission-line conductors. (Vector fields have both magnitude and direction: these must be taken into account when combining fields from different sources.) Important input parameters to the computer program are voltage, current, and geometric configuration of the line. The transmission-line conductors are assumed to be straight, parallel to each other, and located above and parallel to an infinite flat ground plane. Although such conditions do not

occur under real lines because of conductor sag and variable terrain, the validity and limitations of calculations using these assumptions have been well verified by comparisons with measurements. This approach was used to estimate fields for the proposed Santiam - Bethel line, where minimum clearances were assumed to provide worst-case (highest) estimates for the fields.

Electric fields are calculated using an imaging method. Fields from the conductors and their images in the ground plane are superimposed with the proper magnitude and phase to produce the total field at a selected location.

The total magnetic field is calculated from the vector summation of the fields from currents in all the transmission-line conductors. Balanced currents are assumed for each three-phase circuit; the contribution of induced image currents in the conductive earth is not included. Peak currents and power flow direction for the proposed and existing lines were provided by BPA and are based on the projected winter peak power loads in 2006. In the case of corridors with more than one line, calculations were performed for similar (maximum) current conditions on both lines.

Electric and magnetic fields for the proposed line were calculated at the standard height (3.28 ft. or 1 m) above the ground (IEEE, 1987). Calculations were performed out to 300 ft. (91 m) from the centerline of the existing corridor. The validity and limitations of such calculations have been well verified by measurements. Because maximum voltage, maximum current, and minimum conductor height above-ground are used, ***the calculated values given here represent worst-case conditions:*** i.e., the calculated fields are higher than they would be in practice. Such worst-case conditions would seldom occur.

The corona performance of the proposed line was also predicted using the BPA Corona and Field Effects Program (USDOE, undated). Corona performance is calculated using empirical equations that have been developed over several years from the results of measurements on numerous high-voltage lines (Chartier and Stearns, 1981; Chartier, 1983). The validity of this approach for corona-generated audible noise has been demonstrated through comparisons with measurements on other lines all over the United States (IEEE Committee Report, 1982). The accuracy of this method for predicting corona-generated radio and television interference from transmission lines has also been established (Olsen et al., 1992). Important input parameters to the computer program are voltage, current, conductor size, and geometric configuration of the line.

Corona is a highly variable phenomenon that depends on conditions along a length of line. Predictions of the levels of corona effects are reported in statistical terms to account for this variability. Calculations of audible noise and electromagnetic interference levels were made under conditions of an estimated average operating voltage (235 kV for the proposed line) and with the average line height (43 ft. or 13.1 m). Levels of audible noise, radio interference, and television interference are predicted for both fair and foul weather; however, corona is basically a foul-weather phenomenon. Wet conductors can occur during periods of rain, fog, snow, or icing. Along the route of the proposed Santiam - Bethel transmission line, such conditions are expected to occur about 22% of the time during a year, based on hourly records for the Salem airport from 1996 to 1999. Corona activity also increases with altitude. For purposes of evaluating corona effects from the proposed line, an altitude of 500 ft. (152 m) was assumed.

## 2.0 Physical Description

### 2.1 Proposed Line

The proposed double-circuit line would consist of two three-phase circuits, the new Santiam - Bethel 230-kV line and the rebuilt Santiam - Chemawa 230-kV line. Both circuits would have maximum phase-to-phase voltages of 242 kV. The average voltage of the lines would be 235 kV. The maximum electrical current on the lines would be 755 and 644 amperes per phase for the Santiam - Bethel and Santiam - Chemawa lines, respectively. The estimated currents are based on the BPA projected normal winter peak load in 2006. The load factor for these loads is 0.60 (average load = peak load x load factor). BPA provided the physical and operating characteristics of the proposed and existing lines.

The physical dimensions and electrical characteristics for the configuration of the proposed line are shown in Figure 1, and summarized in Table 1. Each phase of the proposed and rebuilt 230-kV lines will have a single 1.600-inch (in.) (4.1 centimeter [cm]) diameter steel-reinforced aluminum conductor (ACSR). Voltage and current waves are displaced by 120° in time (one-third of a cycle) on each electrical phase. The horizontal phase spacing between the upper and lower conductor positions of the two circuits would be 24.5 ft. (7.5 m); the horizontal spacing between the middle conductor positions would be 40.5 ft. (12.3 m). The vertical spacing between the conductor positions would be 18 ft. (5.5 m). Minimum conductor-to-ground clearance would be 31 ft. (9.5 m) at a conductor temperature of 122°F (50°C), which represents maximum operating conditions and high ambient air temperatures; clearances above ground would be greater under normal operating temperatures. The average clearance above ground along a span will be approximately 43 ft. (13.1 m); this value was used for corona calculations. At road crossings, the ground clearance would be at least 39 ft. (11.9 m). The 31-ft. (9.5-m) minimum clearance provided by BPA is greater than the minimum distance of the conductors above ground required to meet the National Electric Safety Code (NESC) (IEEE, 1990). The final design of the proposed line could entail larger clearances. The right-of-way width for the proposed line is 125 ft. (38 m).

### 2.2 Existing Lines

The proposed double-circuit 230-kV line would replace a section of the existing Santiam - Chemawa 230-kV line along the entire route. There are two possible configurations along the existing Santiam - Chemawa line route: either no parallel line or parallel to the existing BPA Marion - Santiam No. 1 and No. 2 double-circuit 500-kV line (Table 2).

BPA provided information on currents for the existing Santiam - Chemawa line and for the Marion - Santiam No.1 500-kV line. The Marion - Santiam No. 2 line is not energized. The physical and electrical characteristics of the corridor configurations that were analyzed are given in Table 1; cross-sections of the corridors are shown in Figure 1.

## 3.0 Electric Field

### 3.1 Basic Concepts

An electric field is said to exist in a region of space if an electrical charge, at rest in that space, experiences a force of electrical origin (i.e., electric fields cause free charges to move). Electric field is a vector quantity: that is, it has both magnitude and direction. The direction corresponds to the direction



that a positive charge would move in the field. Sources of electric fields are unbalanced electrical charges (positive or negative) and time-varying magnetic fields. Transmission lines, distribution lines, house wiring, and appliances generate electric fields in their vicinity because of unbalanced electrical charge on energized conductors. The unbalanced charge is associated with the voltage on the energized system. On the power system in North America, the voltage and charge on the energized conductors are cyclic (plus to minus to plus) at a rate of 60 times per second. This changing voltage results in electric fields near sources that are also time-varying at a frequency of 60 hertz (Hz; a frequency unit equivalent to cycles per second).

As noted earlier, electric fields are expressed in units of volts per meter (V/m) or kilovolts (thousands of volts) per meter (kV/m). Electric- and magnetic-field magnitudes in this report are expressed in root-mean-square (rms) units. For sinusoidal waves, the rms amplitude is given as the peak amplitude divided by the square root of two.

The spatial uniformity of an electric field depends on the source of the field and the distance from that source. On the ground, under a transmission line, the electric field is nearly constant in magnitude and direction over distances of several feet (1 meter). However, close to transmission- or distribution-line conductors, the field decreases rapidly with distance from the conductors. Similarly, near small sources such as appliances, the field is not uniform and falls off even more rapidly with distance from the device. If an energized conductor (source) is inside a grounded conducting enclosure, then the electric field outside the enclosure is zero, and the source is said to be shielded.

Electric fields interact with the charges in all matter, including living systems. When a conducting object, such as a vehicle or person, is located in a time-varying electric field near a transmission line, the external electric field exerts forces on the charges in the object, and electric fields and currents are induced in the object. If the object is grounded, then the total current induced in the body (the "short-circuit current") flows to earth. The distribution of the currents within, say, the human body, depends on the electrical conductivities of various parts of the body: for example, muscle and blood have higher conductivity than bone and would therefore experience higher currents.

At the boundary surface between air and the conducting object, the field in the air and perpendicular to the conductor surface is much, much larger than the field in the conductor itself. For example, the average surface field on a human standing in a 10 kV/m field is 27 kV/m; the internal fields in the body are much smaller: approximately 0.008 V/m in the torso and 0.45 V/m in the ankles.

### **3.2 Transmission-line Electric Fields**

The electric field created by a high-voltage transmission line extends from the energized conductors to other conducting objects such as the ground, towers, vegetation, buildings, vehicles, and people. The calculated strength of the electric field at a height of 3.28 ft. (1 m) above an unvegetated, flat earth is frequently used to describe the electric field under straight parallel transmission lines. The most important transmission-line parameters that determine the electric field at a 1-m height are conductor height above ground and line voltage.

Calculations of electric fields from transmission lines are performed with computer programs based on well-known physical principles (cf., Deno and Zaffanella, 1982). The calculated values under these conditions represent an ideal situation. When practical conditions approach this ideal model, measurements and calculations agree. Often, however, conditions are far from ideal because of variable terrain and vegetation. In these cases, fields are calculated for ideal conditions, with the lowest conductor clearances to provide upper bounds on the electric field under the transmission lines. With the

use of more complex models or empirical results, it is also possible to account accurately for variations in conductor height, topography, and changes in line direction. Because the fields from different sources add vectorially, it is possible to compute the fields from several different lines if the electrical and geometrical properties of the lines are known. However, in general, electric fields near transmission lines with vegetation below are highly complex and cannot be calculated. Measured fields in such situations are highly variable.

For evaluation of EMF from transmission lines, the fields must be calculated for a specific line condition. The NESC states the condition for evaluating electric-field-induced short-circuit current for lines with voltage above 98 kV, line-to-ground, as follows: conductors are at a minimum clearance from ground corresponding to a conductor temperature of 120°F (49°C), and at a maximum voltage (IEEE, 1990). BPA has supplied the needed information for calculating electric and magnetic fields from the proposed transmission lines: the maximum operating voltage, the estimated peak current in 2006, and the minimum conductor clearances.

There are standard techniques for measuring transmission-line electric fields (IEEE, 1987). Provided that the conditions at a measurement site closely approximate those of the ideal situation assumed for calculations, measurements of electric fields agree well with the calculated values. If the ideal conditions are not approximated, the measured field can differ substantially from calculated values. Usually the actual electric field at ground level is reduced from the calculated values by various common objects that act as shields.

Maximum or peak field values occur over a small area at midspan, where conductors are closest to the ground. As the location of an electric-field profile approaches a tower, the conductor clearance increases, and the peak field decreases. A grounded tower will reduce the electric field considerably by shielding. For the parallel-line configuration considered here, minimum conductor clearances were assumed to occur along the same lateral profile for both lines. This condition will not necessarily occur in practice, because the towers for the parallel lines may be offset or located at different elevations. The assumption of simultaneous minimum clearance results in peak fields that may be larger than what occurs in practice.

For traditional transmission lines, such as the proposed line, where the right-of-way extends laterally well beyond the conductors, electric fields at the edge of the right-of-way are not as sensitive as the peak field to conductor height. Computed values at the edge of the right-of-way for any line height are fairly representative of what can be expected all along the transmission-line corridor. However, the presence of vegetation on and at the edge of the right-of-way will reduce actual electric-field levels below calculated values.

### **3.3 Calculated Values of Electric Fields**

Table 3 shows the calculated values of electric field at 3.28 ft. (1 m) above ground for the proposed Santiam - Bethel 230-kV transmission-line configurations. The peak value on the right-of-way and the value at the edge of the right-of-way are given for the two proposed corridor configurations and for minimum and average conductor clearances. Figure 2a shows lateral profiles for the electric field from the proposed and existing lines for the minimum conductor heights. Figure 2b shows calculated fields for the proposed and existing lines in the configuration with a parallel 500-kV line.

The calculated peak electric field expected on the right-of-way of the proposed line is 2.5 kV/m when there are no parallel lines. As shown in Figure 2a, the peak values would be present only at locations directly under the line, near mid-span, where the conductors are at the minimum clearance. The

conditions of minimum conductor clearance at maximum current and maximum voltage occur very infrequently. The calculated peak levels are rarely reached under real-life conditions, because the actual line height is generally above the minimum value used in the computer model, because the actual voltage is below the maximum value used in the model, and because vegetation within and near the edge of the right-of-way tends to shield the field at ground level. Maximum electric field under the existing parallel 500-kV is 8.1 kV/m.

The largest values expected at the edge of the right-of-way nearest the proposed line would be 0.4 kV/m. For the parallel configuration, the field at the edge of the right-of-way nearest the 500-kV line would be 0.3 kV/m. The largest electric fields at the edges of the existing rights-of-way are 1.3 and 2.6 kV/m for the 230- and 500-kV lines, respectively.

### **3.4 Environmental Electric Fields**

The electric fields associated with the Santiam - Bethel line can be compared with those found in other environments. Sources of 60-Hz electric (and magnetic) fields exist everywhere electricity is used; levels of these fields in the modern environment vary over a wide range. Electric-field levels associated with the use of electrical energy are orders of magnitude greater than the naturally occurring 60-Hz fields of about 0.0001 V/m, which stem from atmospheric and extraterrestrial sources.

Electric fields in outdoor, publicly accessible places range from less than 1 V/m to 12 kV/m; the large fields exist close to high-voltage transmission lines of 500 kV or higher. In remote areas without electrical service, 60-Hz field levels can be much lower than 1 V/m. Electric fields in home and work environments generally are not spatially uniform like those of transmission lines; therefore, care must be taken when making comparisons between fields from different sources such as appliances and electric lines. In addition, fields from all sources can be strongly modified by the presence of conducting objects. However, it is helpful to know the levels of electric fields generated in domestic and office environments in order to compare commonly experienced field levels with those near transmission lines.

Numerous measurements of residential electric fields have been reported for various parts of the United States, Canada, and Europe. Although there have been no large studies of residential electric fields, sufficient data are available to indicate field levels and characteristics. Measurements of domestic 60-Hz electric fields indicate that levels are highly variable and source-dependent. Electric-field levels are not easily predicted because walls and other objects act as shields, because conducting objects perturb the field, and because homes contain numerous localized sources. Internal sources (wiring, fixtures, and appliances) seem to predominate in producing electric fields inside houses. Average measured electric fields in residences are generally in the range of 5 to 20 V/m. In a large occupational exposure monitoring project that included electric-field measurements at homes, average exposures for all groups away from work were generally less than 10 V/m (Bracken, 1990).

Electric fields from household appliances are localized and decrease rapidly with distance from the source. Local electric fields measured at 1 ft. (0.3 m) from small household appliances are typically in the range of 30 to 60 V/m. Stopps and Janischewskyj (1979) reported electric-field measurements near 20 different appliances; at a 1-ft. (0.3-m) distance, fields ranged from 1 to 150 V/m, with a mean of 33 V/m. In another survey, reported by Deno and Zaffanella (1982), field measurements at a 1-ft. (0.3-m) distance from common domestic and workshop sources were found to range from 3 to 70 V/m. The localized fields from appliances are not uniform, and care should be taken in comparing them with transmission-line fields.

Electric blankets can generate higher localized electric fields. Sheppard and Eisenbud (1977) reported fields of 250 V/m at a distance of approximately 1 ft. (0.3 m). Florig et al. (1987) carried out extensive empirical and theoretical analysis of electric-field exposure from electric blankets and presented results in terms of uniform equivalent fields such as those near transmission lines. Depending on what parameter was chosen to represent intensity of exposure and the grounding status of the subject, the equivalent vertical 60-Hz electric-field exposure ranged from 20 to over 3500 V/m. The largest equivalent field corresponds to the measured field on the chest with the blanket-user grounded. The average field on the chest of an ungrounded blanket-user yields an equivalent vertical field of 960 V/m. As manufacturers have become aware of the controversy surrounding EMF exposures, electric blankets have been redesigned to reduce magnetic fields. However, electric fields from these “low field” blankets are still comparable with those from older designs (Bassen et al., 1991).

Generally, people in occupations not directly related to high-voltage equipment are exposed to electric fields comparable with those of residential exposures. For example, the average electric field measured in 14 commercial and retail locations in rural Wisconsin and Michigan was 4.8 V/m (ITT Research Institute, 1984). Median electric field was about 3.4 V/m. These values are about one-third the values in residences reported in the same study. Power-frequency electric fields near video display terminals (VTDs) are about 10 V/m, similar to those of other appliances (Harvey, 1983). Electric-field levels in public buildings such as shops, offices, and malls appear to be comparable with levels in residences.

In a survey of 1,882 volunteers from utilities, electric-field exposures were measured for 2,082 work days and 657 non-work days (Bracken, 1990). Electric-field exposures for occupations other than those directly related to high-voltage equipment were equivalent to those for non-work exposure.

Thus, except for the relatively few occupations where high-voltage sources are prevalent, electric fields encountered in the workplace are probably similar to those of residential exposures. Even in electric-utility occupations where high field sources are present, exposures to high fields are limited on average to minutes per day.

Electric fields found in publicly accessible areas near high-voltage transmission lines can typically range up to 3 kV/m for 230-kV lines, to 10 kV/m for 500-kV lines, and to 12 kV/m for 765-kV lines. Although these peak levels are considerably higher than the levels found in other public areas, they are present only in limited areas on rights-of-way.

The calculated electric fields for the proposed Santiam - Bethel 230-kV transmission line are consistent with the levels reported for other 230-kV transmission lines in Oregon and elsewhere. The electric fields on and at the edge of the right-of-way from the proposed line will be less than those from the Santiam - Chemawa 230-kV line that would be replaced. Electric fields from the existing 500-kV line will remain the same and be larger than those from the proposed or existing 230-kV lines. The calculated electric fields on the right-of-way of the proposed transmission line would be much higher than levels normally encountered in residences and offices.

## **4.0 Magnetic Field**

### **4.1 Basic Concepts**

Magnetic fields can be characterized by the force they exert on a moving charge or on an electrical current. As with the electric field, the magnetic field is a vector quantity characterized by both magnitude and direction. Electrical currents generate magnetic fields. In the case of transmission lines,

distribution lines, house wiring, and appliances, the 60-Hz electric current flowing in the conductors generates a time-varying, 60-Hz magnetic field in the vicinity of these sources. The strength of a magnetic field is measured in terms of magnetic lines of force per unit area, or magnetic flux density. The term “magnetic field,” as used here, is synonymous with magnetic flux density and is expressed in units of Gauss (G) or milligauss (mG).

The uniformity of a magnetic field depends on the nature and proximity of the source, just as the uniformity of an electric field does. Transmission-line-generated magnetic fields are quite uniform over horizontal and vertical distances of several feet near the ground. However, for small sources such as appliances, the magnetic field decreases rapidly over distances comparable with the size of the device.

The interaction of a time-varying magnetic field with conducting objects results in induced electric field and currents in the object. A changing magnetic field through an area generates a voltage around any conducting loop enclosing the area (Faraday's law). This is the physical basis for the operation of an electrical transformer. For a time-varying sinusoidal magnetic field, the magnitude of the induced voltage around the loop is proportional to the area of the loop, the frequency of the field, and the magnitude of the field. The induced voltage around the loop results in an induced electric field and current flow in the loop material. The induced current that flows in the loop depends on the conductivity of the loop.

## **4.2 Transmission-line Magnetic Fields**

The magnetic field generated by currents on transmission-line conductors extends from the conductors through the air and into the ground. The magnitude of the field at a height of 3.28 ft. (1 m) is frequently used to describe the magnetic field under transmission lines. Because the magnetic field is not affected by non-ferrous materials, the field is not influenced by normal objects on the ground under the line. The direction of the maximum field varies with location. (The electric field, by contrast, is essentially vertical near the ground.) The most important transmission-line parameters that determine the magnetic field at 3.28 ft. (1 m) height are conductor height above ground and magnitude of the currents flowing in the conductors. As distance from the transmission-line conductors increases, the magnetic field decreases.

Calculations of magnetic fields from transmission lines are performed using well-known physical principles (cf., Deno and Zaffanella, 1982). The calculated values usually represent the ideal straight parallel-conductor configuration. For simplicity, a flat earth is usually assumed. Balanced currents (currents of the same magnitude for each phase) are also assumed. This is usually valid for transmission lines, where loads on all three phases are maintained in balance during operation. Induced image currents in the earth are usually ignored for calculations of magnetic field under or near the right-of-way. The resulting error is negligible. Only at distances greater than 300 ft. (91 m) from a line do such contributions become significant (Deno and Zaffanella, 1982). The clearance for magnetic-field calculations for the proposed line was the same as that used for electric-field evaluations.

Standard techniques for measuring magnetic fields near transmission lines are described in ANSI IEEE Standard No. 644-1987 (1987). Measured magnetic fields agree well with calculated values, provided the currents and line heights that go into the calculation correspond to the actual values for the line. To realize such agreement, it is necessary to get accurate current readings during field measurements (because currents on transmission lines can vary considerably over short periods of time) and also to account for all field sources in the vicinity of the measurements.

As with electric fields, the maximum or peak magnetic fields occur in areas near the centerline and at midspan where the conductors are the lowest. The magnetic field at the edge of the right-of-way is not very dependent on line height. If more than one line is present, the peak field will depend on the relative electrical phasing of the conductors and the direction of power flow. Phasing information was available for the parallel 500-kV line. Phasing of the proposed line was selected to minimize magnetic field at the edge of the right-of-way.

### 4.3 Calculated Values for Magnetic Fields

Table 4 gives the calculated values of the magnetic field at 3.28 ft. (1 m) height for the proposed 230-kV transmission-line corridor. Field values on the right-of-way and at the edge of the right-of-way are given for projected maximum currents during winter peak load in 2006, for minimum and average conductor clearances. The maximum currents are 755 A on each of the three phases of the proposed Santiam - Bethel 230-kV line and 644 A on the rebuilt Santiam - Chemawa 230-kV line. Figure 3 shows lateral profiles of maximum magnetic field under this current condition for the two possible corridors of the proposed 230-kV transmission line. The actual magnetic-field levels would vary, as currents on the lines change daily and seasonally and as ambient temperature changes. Average currents over the year would be about 60% of the maximum values. The levels shown in the figures represent the highest magnetic fields expected for the proposed Santiam - Bethel/Santiam - Chemawa 230-kV line. Average fields over a year would be considerably reduced from the peak values, as a result of increased clearances above the minimum value and reduced currents from the maximum value.

The maximum calculated 60-Hz magnetic field expected at 3.28 ft. (1 m) above ground for the proposed line is 87 mG for the proposed line alone and 94 mG when the line parallels the 500-kV line. This field is calculated for the maximum current of 755 A, with the conductors at a height of 31 ft. (9.5 m). The maximum field would decrease for increased conductor clearance. For an average conductor height over a span of 43 ft. (13.1 m), the maximum field would be 50 mG and 58 mG for the proposed line alone and parallel to the 500-kV line, respectively.

At the edge of the right-of-way of the proposed line, the calculated magnetic field for maximum current load conditions is 26 mG. When the line is located parallel to the existing 500-kV line, the field at the edge of the right-of-way adjacent to the proposed line would be 29 mG.

The magnetic field falls off rapidly as distance from the line increases. At a distance of 200 ft. (61 m) from the centerline of the proposed line, the field would be 4 mG for maximum current conditions. The calculated magnetic field for maximum current would be less than 10 mG at about 120 ft. (37 m) from the centerline.

The calculated fields for the two corridors with existing transmission lines are given in Table 4. For the existing lines, the peak magnetic fields on the rights-of-way are 218 mG and 108 mG, for the 230- and 500-kV lines, respectively. Fields at the edges of the existing rights-of-way are 78 mG and 50 mG for the 230- and 500-kV lines, respectively. Addition of the proposed line will not significantly change the magnetic fields under, or at the edge of, the right-of-way of the existing 500-kV line.

### 4.4 Environmental Magnetic Fields

Transmission lines are not the only source of magnetic fields; as with 60-Hz electric fields, 60-Hz magnetic fields are present throughout the environment of a society that relies on electricity as a principal energy source. The magnetic fields associated with the proposed Santiam - Bethel 230-kV line can be compared with fields from other sources. The range of 60-Hz magnetic-field exposures in publicly

accessible locations such as open spaces, transmission-line rights-of-way, streets, pedestrian walkways, parks, shopping malls, parking lots, shops, hotels, public transportation, and so on range from less than 0.1 mG to about 1 G, with the highest values occurring near small appliances with electric motors. In occupational settings in electric utilities, where high currents are present, magnetic-field exposures for workers can be above 1 G. At 60 Hz, the magnitude of the natural magnetic field is approximately 0.0005 mG.

Several investigations of residential fields have been conducted. In a large study to identify and quantify significant sources of 60-Hz magnetic fields in residences, measurements were made in 996 houses, randomly selected throughout the country (Zaffanella, 1993). The most common sources of residential fields were power lines, the grounding system of residences, and appliances. Field levels were characterized by both point-in-time (spot) measurements and 24-hour measurements. Spot measurements averaged over all rooms in a house exceeded 0.6 mG in 50% of the houses and 2.9 mG in 5% of houses. Power lines generally produced the largest average fields in a house over a 24-hour period. On the other hand, grounding system currents proved to be a more significant source of the highest fields in a house. Appliances were found to produce the highest local fields; however, fields fell off rapidly with increased distance. For example, the median field near microwave ovens was 36.9 mG at a distance of 10.5 in. (0.27 m) and 2.1 mG at 46 in. (1.17 m). Across the entire sample of 996 houses, higher magnetic fields were found in, among others, urban areas (vs. rural); multi-unit dwellings (vs. single-family); old houses (vs. new); and houses with grounding to a municipal water system.

In an extensive measurement project to characterize the magnetic-field exposure of the general population, over 1000 randomly selected persons in the United States wore a personal exposure meter for 24 hours and recorded their location in a simple diary (Zaffanella and Kalton, 1998). Based on the measurements of 853 persons, the estimated 24-hour average exposure for the general population is 1.24 mG and the estimated median exposure is 0.88 mG. The average field "at home, not in bed" is 1.27 mG and "at home, in bed" is 1.11 mG. Average personal exposures were found to be largest "at work" (mean of 1.79 mG and median of 1.01 mG) and lowest "at home, in bed" (mean of 1.11 mG and median of 0.49 mG). Average fields in school were also low (mean of 0.88 mG and median of 0.69 mG). Factors associated with higher exposures at home were smaller residences, duplexes and apartments, metallic rather than plastic water pipes, and nearby overhead distribution lines.

As noted above, magnetic fields from appliances are localized and decrease rapidly with distance from the source. Localized 60-Hz magnetic fields have been measured near about 100 household appliances such as ranges, refrigerators, electric drills, food mixers, and shavers (Gauger, 1985). At a distance of 1 ft. (0.3 m), the maximum magnetic field ranged from 0.3 to 270 mG, with 95% of the measurements below 100 mG. Ninety-five percent of the levels at a distance of 4.9 ft. (1.5 m) were less than 1 mG. Devices that use light-weight, high-torque motors with little magnetic shielding exhibited the largest fields. These included vacuum cleaners and small hand-held appliances and tools. Microwave ovens with large power transformers also exhibited relatively large fields. Electric blankets have been a much-studied source of magnetic-field exposure because of the length of time they are used and because of the close proximity to the body. Florig and Hoburg (1988) estimated that the average magnetic field in a person using an electric blanket was 15 mG, and that the maximum field could be 100 mG. New "low-field" blankets have magnetic fields at least 10 times lower than those from conventional blankets (Bassen et al., 1991).

In a domestic magnetic-field survey, Silva et al. (1989) measured fields near different appliances at locations typifying normal use (e.g., sitting at a typewriter or standing at a stove). Specific appliances with relatively large fields included can openers (n = 9), with typical fields ranging from 30 to 225 mG and a maximum value up to 2.7 G; shavers (n = 4), with typical fields from 50 to 300 mG and maximum

fields up to 6.9 G; and electric drills ( $n = 2$ ), with typical fields from 56 to 190 mG and maximum fields up to 1.5 G. The fields from such appliances fall off very rapidly with distance and are only present for short periods. Thus, although instantaneous magnetic-field levels close to small hand-held appliances can be quite large, they do not contribute to average area levels in residences.

Although studies of residential magnetic fields have not all considered the same independent parameters, the following consistent characterization of residential magnetic fields emerges from the data:

- (1) External sources play a large role in determining residential magnetic-field levels. Transmission lines, when nearby, are an important external source. Unbalanced ground currents on neutral conductors and other conductors, such as water pipes in and near a house, can represent a significant source of magnetic field. Distribution lines per se, unless they are quite close to a residence, do not appear to be a traditional distance-dependent source.
- (2) Homes with overhead electrical service appear to have higher average fields than those with underground service.
- (3) Appliances represent a localized source of magnetic fields that can be much higher than average or area fields. However, fields from appliances approach area levels at distances greater than 3 ft. (1 m) from the device.

Although important variables in determining residential magnetic fields have been identified, quantification and modeling of their influence on fields at specific locations is not yet possible. However, a general characterization of residential magnetic-field level is possible: average levels in the United States are in the range of 0.5 to 1.0 mG, with the average field in a small number of homes exceeding this range by as much as a factor of 10 or more. Average personal exposure levels are slightly higher, possibly due to use of appliances and varying distances to other sources. Maximum fields can be much higher.

Magnetic fields in commercial and retail locations are comparable with those in residences. As with appliances, certain equipment or machines can be a local source of higher magnetic fields. Utility workers who work close to transformers, generators, cables, transmission lines, and distribution systems clearly experience high-level fields. Other sources of fields in the workplace include motors, welding machines, computers, and video display terminals (VDTs). In publicly accessible indoor areas, such as offices and stores, field levels are generally comparable with residential levels, unless a high-current source is nearby.

Because high-current sources of magnetic field are more prevalent than high-voltage sources, occupational environments with relatively high magnetic fields encompass a more diverse set of occupations than do those with high electric fields. For example, in occupational magnetic-field measurements reported by Bowman et al. (1988), the geometric mean field from 105 measurements of magnetic field in "electrical worker" job locations was 5.0 mG. "Electrical worker" environments showed the following elevated magnetic-field levels (geometric mean greater than 20 mG): industrial power supplies, alternating current (ac) welding machines, and sputtering systems for electronic assembly. For secretaries in the same study, the geometric mean field was 3.1 mG for those using VDTs ( $n = 6$ ) and 1.1 mG for those not using VDTs ( $n = 3$ ).

Measurements of personal exposure to magnetic fields were made for 1,882 volunteer utility workers for a total of 4,411 workdays (Bracken, 1990). Median workday mean exposures ranged from 0.5 mG for clerical workers without computers to 7.2 mG for substation operators. Occupations not specifically associated with transmission and distribution facilities had median workday exposures less than 1.5 mG,



while those associated with such facilities had median exposures above 2.3 mG. Magnetic-field exposures measured in homes during this study were comparable with those recorded in offices.

Magnetic fields in publicly accessible outdoor areas seem to be, as expected, directly related to proximity to electric-power transmission and distribution facilities. Near such facilities, magnetic fields are generally higher than indoors (residential). Higher-voltage facilities tend to have higher fields. Typical maximum magnetic fields in publicly accessible areas near transmission facilities can range from less than a few milligauss up to 300 mG or more, near heavily loaded lines operated at 230 to 765 kV. The levels depend on the line load, conductor height, and location on the right-of-way. Because magnetic fields near high-voltage transmission lines depend on the current in the line, they can vary daily and seasonally. To characterize fields from the distribution system, Heroux (1987) measured 60-Hz magnetic fields with a mobile platform along 140 mi. (223 km) of roads in Montreal. The median field level averaged over nine different routes was 1.6 mG, with 90% of the measurements less than about 5.1 mG. Spot measurements indicated that typical fields directly above underground distribution systems were 5 to 19 mG. Beneath overhead distribution lines, typical fields were 1.5 to 5 mG on the primary side of the transformer, and 4 to 10 mG on the secondary side. Near ground-based transformers used in residential areas, fields were 80 to 1000 mG at the surface and 10 to 100 mG at a distance of 1 ft. (0.3 m).

The magnetic fields from the proposed 230-kV transmission line would be less than those from the existing 230-kV line that is being replaced. The fields from the proposed line would be comparable to or less than those from existing 230-kV lines in Oregon and elsewhere. On and near the right-of-way of the proposed line, magnetic fields would be well above average residential levels. However, the fields from the line would decrease rapidly and approach common ambient levels at distances greater than a few hundred feet from the line. Furthermore, the fields at the edge of the right-of-way would not be above those encountered during normal activities near common sources such as hand-held appliances.

## **5.0 Electric and Magnetic Field (EMF) Effects**

Possible effects associated with the interaction of EMF from transmission lines with people on and near a right-of-way fall into two categories: short-term effects that can be perceived and may represent a nuisance, and possible long-term health effects. Only short-term effects are discussed here. The issue of whether there are long-term health effects associated with transmission-line fields is controversial. In recent years, considerable research on possible biological effects of EMF has been conducted. A review of these studies and their implications for health-related effects is provided in a separate technical report for the environmental assessment for the proposed Santiam - Bethel 230-kV transmission line.

### **5.1 Electric Fields: Short-term Effects**

Short-term effects from transmission-line electric fields are associated with perception of induced currents and voltages or perception of the field. Induced current or spark discharge shocks can be experienced under certain conditions when a person contacts objects in an electric field. Such effects occur in the fields associated with transmission lines that have voltages of 230-kV or higher. These effects could occur infrequently under the proposed Santiam - Bethel 230-kV line. The higher electric fields under the existing 500-kV Marion-Santiam line are much more likely to result in such effects.

Steady-state currents are those that flow continuously after a person contacts an object and provides a path to ground for the induced current. The amplitude of the steady-state current depends on the induced current to the object in question and on the grounding path. The magnitude of the induced current to vehicles and objects under the proposed line will depend on the electric-field strength and the size and

shape of the object. When an object is electrically grounded, the voltage on the object is reduced to zero, and it is not a source of current or voltage shocks. If the object is poorly grounded or not grounded at all, then it acquires some voltage relative to earth and is a possible source of current or voltage shocks.

The responses of persons to steady-state current shocks have been extensively studied, and levels of response documented (Keeseey and Letcher, 1969; IEEE, 1978). Primary shocks are those that can result in direct physiological harm. Such shocks will not be possible from induced currents under the existing or proposed lines, because clearances above ground required by the NESC preclude such shocks from large vehicles and grounding practices eliminate large stationary objects as sources of such shocks.

Secondary shocks are defined as those that could cause an involuntary and potentially harmful movement, but no direct physiological harm. Secondary shocks could occur under the proposed 230-kV line when making contact with ungrounded conducting objects such as vehicles or equipment. However, such occurrences are anticipated to be very infrequent. Shocks, when they occur under the 230-kV line, are most likely to be below the nuisance level. Induced currents are extremely unlikely to be perceived off the right-of-way of the proposed line.

Induced currents are always present in electric fields under transmission lines and will be present near the proposed line. However, during initial construction, BPA routinely grounds metal objects that are located on or near the right-of-way. The grounding eliminates these objects as sources of induced current and voltage shocks. Multiple grounding points are used to provide redundant paths for induced current flow. After construction, BPA would respond to any complaints and install or repair grounding to mitigate nuisance shocks.

Unlike fences or buildings, mobile objects such as vehicles and farm machinery cannot be grounded permanently. Limiting the possibility of induced currents from such objects to persons is accomplished in several ways. First, required clearances for above-ground conductors tend to limit field strengths to levels that do not represent a hazard or nuisance. The NESC (IEEE, 1990) requires that, for lines with voltage exceeding 98 kV line-to-ground (170 kV line-to-line), sufficient conductor clearance be maintained to limit the induced short-circuit current in the largest anticipated vehicle under the line to 5 milliamperes (mA) or less. This can be accomplished by limiting access or by increasing conductor clearances in areas where large vehicles could be present. BPA and other utilities design and operate lines to be in compliance with the NESC.

For the proposed line, conductor clearances (50°C conductor temperature) would be increased to at least 39 ft. (11.9 m) over road crossings along the route, resulting in a maximum field of 1.7 kV/m or less at the 3.28 ft. (1 m) height. The largest truck allowed on roads in Oregon without a special permit is 14 feet high by 8.5 feet wide by 75 feet long (4.3 x 2.6 x 22.9 m). The induced currents to such a vehicle oriented perpendicular to the line in a maximum field of 1.7 kV/m (at 3.28-foot height) would be less than 1.5 mA (Reilly, 1979). For smaller trucks, the maximum induced currents for perpendicular orientation to the proposed line would be less than this value. (Larger special-permitted trucks, such as triple trailers, can be up to 105 feet in length. However, because they average the field over such a long distance, the maximum induced current to a 105-foot vehicle oriented perpendicular to the 230-kV line at a road crossing would be less than 1.4 mA.) Thus, the NESC 5-mA criterion would be met for perpendicular road crossings of the proposed line. These large vehicles are not anticipated to be off highways or oriented parallel to the proposed line. Even if they were, the NESC 5-mA criterion would be met under the proposed line. As discussed below, these are worst-case estimates of induced currents at road crossings; conditions for their occurrence are rare. The conductor clearance at each road crossing would be checked during the design stage of the line to ensure that the NESC 5-mA criterion is met. Furthermore, it is BPA policy to limit the maximum induced current from vehicles to 2 mA in

commercial parking lots. Line clearances would also be increased in accordance with the NESC, such as over railroads and water areas suitable for sailboating.

Several factors tend to reduce the levels of induced current shocks from vehicles:

- (1) Activities are distributed over the whole right-of-way, and only a small percentage of time is spent in areas where the field is at or close to the maximum value.
- (2) At road crossings, vehicles are aligned perpendicular to the conductors, resulting in a substantial reduction in induced current.
- (3) The conductor clearance at road crossings may not be at minimum values because of lower conductor temperatures and/or location of the road crossing away from midspan.
- (4) The largest vehicles are permitted only on certain highways.
- (5) Off-road vehicles are in contact with soil or vegetation, which reduces shock currents substantially.

Induced voltages occur on objects, such as vehicles, in an electric field where there is an inadequate electrical ground. If the voltage is sufficiently high, then a spark discharge shock can occur as contact is made with the object. Such shocks are similar to "carpet" shocks that occur, for example, when a person touches a doorknob after walking across a carpet on a dry day.

In electric fields higher than will occur under the proposed line, it is theoretically possible for a spark discharge from the induced voltage on a large vehicle to ignite gasoline vapor during refueling. The probability for exactly the right conditions to occur for ignition is extremely remote. The additional clearance of conductors provided at road crossings reduces the electric field in areas where vehicles are prevalent and reduces the chances for such events. Even so, BPA recommends that vehicles should not be refueled under the proposed line unless specific precautions are taken to ground the vehicle and the fueling source (USDOE, 1995).

Under certain conditions, the electric field can be perceived through hair movement on an upraised hand or arm of a person standing on the ground under high-voltage transmission lines. The median field for perception in this manner was 7 kV/m for 136 persons; only about 12% could perceive fields of 2 kV/m or less (Deno and Zaffanella, 1982). Even in areas under the conductors at midspan, the fields at ground level would be below the levels where field perception normally occurs. Therefore, it is unlikely that the field would be perceived anywhere on the right-of-way. Where vegetation provides shielding, the field would not be perceived.

Conductive shielding reduces both the electric field and induced effects such as shocks. Persons inside a vehicle cab or canopy are shielded from the electric field. Similarly, a row of trees or a lower-voltage distribution line reduces the field on the ground in the vicinity. Metal pipes, wiring, and other conductors in a residence or building shield the interior from the transmission-line electric field.

Thus, potential impacts of electric fields can be mitigated through grounding policies, adherence to the NESC, and increased clearances above the minimums specified by the NESC. Worst-case levels are used for safety analyses but, in practice, induced currents and voltages are reduced considerably by unintentional grounding. Shielding by conducting objects, such as vehicles and vegetation, also reduces the potential for electric-field effects.

The electric fields from the proposed 230-kV line will be less than those from the line it is replacing. Therefore the potential for impacts of electric fields will be reduced from that now present on the existing right-of-way. The potential for effects from the parallel 500-kV line will remain the same.

## **5.2 Magnetic Field: Short-term Effects**

Magnetic fields associated with transmission and distribution systems can induce voltage and current in long conducting objects that are parallel to the transmission line. As with electric-field induction, these induced voltages and currents are a potential source of shocks. A fence, irrigation pipe, pipeline, electrical distribution line, or telephone line forms a conducting loop when it is grounded at both ends. The earth forms the other portion of the loop. The magnetic field from a transmission line can induce a current to flow in such a loop if it is oriented parallel to the line. If only one end of the fence is grounded, then an induced voltage appears across the open end of the loop. The possibility for a shock exists if a person closes the loop at the open end by contacting both the ground and the conductor. The magnitude of this potential shock depends on the following factors: the magnitude of the field; the length of the object (the longer the object, the larger the induced voltage); the orientation of the object with respect to the transmission line (parallel as opposed to perpendicular, where no induction would occur); and the amount of electrical resistance in the loop (high resistance limits the current flow).

Magnetically induced currents from power lines have been investigated for many years; calculation methods and mitigating measures are available. A comprehensive study of gas pipelines near transmission lines developed prediction methods and mitigation techniques specifically for induced voltages on pipelines (Dabkowski and Taflove, 1979; Taflove and Dabkowski, 1979). Similar techniques and procedures are available for irrigation pipes and fences. Grounding policies employed by utilities for long fences reduce the potential magnitude of induced voltage.

The magnitude of the coupling with both pipes and fences is very dependent on the electrical unbalance (unequal currents) among the three phases of the line. Thus, a distribution line where a phase outage may go unnoticed for long periods of time can represent a larger source of induced currents than a transmission line where the loads are well-balanced (Jaffa and Stewart, 1981).

Knowledge of the phenomenon, grounding practices, and the availability of mitigation measures mean that magnetic-induction effects from the proposed 230-kV transmission line will be minimal.

Magnetic fields from transmission and distribution facilities can interfere with certain electronic equipment. Magnetic fields can cause distortion of the image on VDTs and computer monitors. The threshold field for interference depends on the type and size of monitor and the frequency of the field. Interference has been observed for certain monitors at fields at or below 10 mG (Baishiki et al., 1990; Banfai et al., 2000). Generally, the problem arises when computer monitors are in use near electrical distribution facilities in large office buildings. Fields from the proposed line would fall below this level at approximately 120 ft. (37 m) from the centerline.

Interference from magnetic fields can be eliminated by shielding the affected monitor or moving it to an area with lower fields. Similar mitigation methods could be applied to other sensitive electronics, if necessary. Interference from 60-Hz fields with computers and control circuits in vehicles and other equipment is not anticipated at the field levels found under and near the proposed 230-kV transmission line.

The magnetic fields from the proposed line will be less than those from the existing line that is being replaced. Therefore the potential for impacts from magnetic fields will be reduced from that on the existing right-of-way. The potential for effects from the parallel 500-kV line will remain the same.

## **6.0 Regulations**

Regulations that apply to transmission-line electric and magnetic fields fall into two categories. Safety standards or codes are intended to limit or eliminate electric shocks that could seriously injure or kill persons. Field limits or guidelines are intended to limit electric- and magnetic-field exposures that can cause nuisance shocks or might cause health effects. In no case has a limit or standard been established because of a known or demonstrated health effect.

The proposed line would be designed to meet the NESC (IEEE, 1990), which specifies how far transmission-line conductors must be from the ground and other objects. The clearances specified in the code provide safe distances that prevent harmful shocks to workers and the public. In addition, people who live and work near transmission lines must be aware of safety precautions to avoid electrical (which is not necessarily physical) contact with the conductors. For example, farmers should not up-end irrigation pipes under a transmission or other electrical line. In addition, as a matter of safety, the NESC specifies that electric-field-induced currents from transmission lines must be below the 5 mA (“let go”) threshold deemed a lower limit for primary shock. BPA publishes and distributes a brochure that describes safe practices to protect against shock hazards around power lines (USDOE, 1995).

Field limits or guidelines have been adopted in several states and countries and by national and international organizations. Electric-field limits have generally been based on minimizing nuisance shocks or field perception. The intent of magnetic-field limits has been to limit exposures to existing levels, given the uncertainty of their potential for health effects.

There are currently no national standards in the United States for 60-Hz electric and magnetic fields. Several states have been active in establishing mandatory or suggested limits on 60-Hz electric and (in two cases) magnetic fields. Six states have specific electric-field limits that apply to transmission lines: Florida, Minnesota, Montana, New Jersey, New York, and Oregon. Florida and New York have established regulations for magnetic fields. These regulations are summarized in Table 5, adapted from TDHS Report (1989).

Electric-field limits for the states have been given in terms of maximum field or edge-of-right-of-way field, or both. The Oregon limit of 9 kV/m for electric fields is applied to areas accessible to the public (Oregon, 1980). The Oregon rule, which is found in transmission-line siting procedures also addresses grounding practices, audible noise, and radio interference.

Government agencies and utilities operating transmission systems have established design criteria that include EMF levels. BPA has maximum allowable electric fields of 9 and 5 kV/m on and at the edge of the right-of-way, respectively (USDOE, 1996). BPA also has maximum-allowable electric field strengths of 5 kV/m, 3.5 kV/m, and 2.5 kV/m for road crossings, shopping center parking lots, and commercial/industrial parking lots, respectively. These levels are based on limiting the maximum short-circuit currents from anticipated vehicles to less than 1 mA in shopping center lots and to less than 2 mA in commercial parking lots.

Electric-field limits for overhead power lines have also been established in other countries (Maddock, 1992). Limits for magnetic fields from overhead power lines have not been explicitly established

anywhere except in Florida and New York. However, general guidelines and limits on EMF have been established for occupational and public exposure in several countries and by national and international organizations.

The American Conference of Governmental Industrial Hygienists (ACGIH) sets guidelines (Threshold Limit Values or TLV) for occupational exposures to environmental agents (ACGIH, 2000). In general, a TLV represents the level below which it is believed that nearly all workers may be exposed repeatedly without adverse health effects. For EMF, the TLVs represent ceiling levels. For 60-Hz electric fields, occupational exposures should not exceed the TLV of 25 kV/m. However, the ACGIH also recognizes the potential for startle reactions from spark discharges and short-circuit currents in fields greater than 5-7 kV/m, and recommends implementing grounding practices. They recommend the use of conductive clothing for work in fields exceeding 15 kV/m. The TLV for occupational exposure to 60-Hz magnetic fields is a ceiling level of 10 G (10,000 mG) (ACGIH, 2000).

Electric and magnetic fields from various sources (including automobile ignitions, appliances, and, possibly, transmission lines) can interfere with implanted cardiac pacemakers. In light of this potential problem, manufacturers design devices to be immune from such interference. However, research has shown that these efforts have not been completely successful and that a few models of pacemakers could be affected by 60-Hz fields from transmission lines. There were also numerous models of pacemakers that were not affected by fields even larger than those found under transmission lines. Because of the known potential for interference with pacemakers by 60-Hz fields, field limits for pacemaker wearers have been established by the ACGIH. They recommend that wearers of pacemakers and similar medical-assist devices limit their exposure to electric fields of 1 kV/m or less and to magnetic fields to 1 G (1,000 mG) or less (ACGIH, 2000).

The International Committee on Non-ionizing Radiation Protection (ICNIRP), working in cooperation with the World Health Organization (WHO) has developed guidelines for occupational and public exposures to EMF (ICNIRP, 1998). For occupational exposures at 60 Hz, the recommended limits to exposure are 8.3 kV/m for electric fields and 4.2 G (4,200 mG) for magnetic fields. The electric-field level can be exceeded, provided precautions are taken to prevent spark discharge and induced current shocks. For the general public, the ICNIRP guidelines recommend exposure limits of 4.2 kV/m for electric fields and 0.83 G (830 mG) for magnetic fields (ICNIRP, 1998).

ICNIRP has also established guidelines for contact currents, which could occur when a grounded person contacts an ungrounded object in an electric field. The guideline levels are 1.0 mA for occupational exposure and 0.5 mA for public exposure.

The estimated peak electric field and magnetic field on, and at the edge of, the right-of-way of the proposed transmission line would meet limits set in all states, including Oregon. The electric fields from the proposed 230-kV line would meet the ACGIH standards, provided wearers of pacemakers and similar medical-assist devices are discouraged from unshielded right-of-way use. (A passenger in an automobile under the line would be shielded from the electric field.) The electric fields from the proposed line would meet the ICNIRP guideline for public exposure. The magnetic fields from the proposed line would be below the ACGIH and IRPA/INIRC limits. The electric fields present on the right-of-way could induce currents in ungrounded vehicles that exceeded the ICNIRP level of 0.5 mA.

## **7.0 Audible Noise**

### **7.1 Basic Concepts**

Audible noise (AN), as defined here, represents an unwanted sound, as from a transmission line, transformer, airport, or vehicle traffic. Sound is a pressure wave caused by a sound source vibrating or displacing air. The ear converts the pressure fluctuations into auditory sensations. AN from a source is superimposed on the background or ambient noise that is present before the source is introduced.

The amplitude of a sound wave is the incremental pressure resulting from sound above atmospheric pressure. The sound-pressure level is the fundamental measure of AN; it is generally measured on a logarithmic scale with respect to a reference pressure. The sound-pressure level (SPL) in decibels (dB) is given by:

$$\text{SPL} = 20 \log (P/P_0)\text{dB}$$

where P is the effective rms (root-mean-square) sound pressure,  $P_0$  is the reference pressure, and the logarithm (log) is to the base 10. The reference pressure for measurements concerned with hearing is usually taken as 20 micropascals (Pa), which is the approximate threshold of hearing for the human ear. A logarithmic scale is used to encompass the wide range of sound levels present in the environment. The range of human hearing is from 0 dB up to about 140 dB, a ratio of 10 million in pressure (EPA, 1978).

Logarithmic scales, such as the decibel scale, are not directly additive: to combine decibel levels, the dB values must be converted back to their respective equivalent pressure values, the total rms pressure level found, and the dB value of the total recalculated. For example, adding two sounds of equal level on the dB scale results in a 3 dB increase in sound level. Such an increase in sound pressure level of 3 dB, which corresponds to a doubling of the energy in the sound wave, is barely discernible by the human ear. It requires an increase of about 10 dB in SPL to produce a subjective doubling of sound level for humans. The upper range of hearing for humans (140 dB) corresponds to a sharply painful response (EPA, 1978).

Humans respond to sounds in the frequency range of 16 to 20,000 Hz. The human response depends on frequency, with the most sensitive range roughly between 2000 and 4000 Hz. The frequency-dependent sensitivity is reflected in various weighting scales for measuring audible noise. The A-weighted scale weights the various frequency components of a noise in approximately the same way that the human ear responds. This scale is generally used to measure and describe levels of environmental sounds such as those from vehicles or occupational sources. The A-weighted scale is also used to characterize transmission-line noise. Sound levels measured on the A-scale are expressed in units of dB(A) or dBA.

AN levels and, in particular, corona-generated audible noise (see below) vary in time. In order to account for fluctuating sound levels, statistical descriptors have been developed for environmental noise. Exceedence levels (L levels) refer to the A-weighted sound level that is exceeded for a specified percentage of the time. Thus, the  $L_5$  level refers to the noise level that is exceeded only 5% of the time.  $L_{50}$  refers to the sound level exceeded 50% of the time. Sound-level measurements and predictions for transmission lines are often expressed in terms of exceedence levels, with the  $L_5$  level representing the maximum level and the  $L_{50}$  level representing a median level.

Table 6 shows AN levels from various common sources. Clearly, there is wide variation. Noise exposure depends on how much time an individual spends in different locations. Outdoor noise generally does not contribute to indoor levels (EPA, 1974). Activities in a building or residence generally dominate interior AN levels. The amount of sound attenuation (reduction) provided by buildings is given in Table 7. Assuming that residences along the line route fall in the "warm climate, windows open" category, the typical sound attenuation provided by a house is about 12 dBA.

The BPA design criterion for corona-generated audible noise ( $L_{50}$ , foul weather) is  $50 \pm 2$  dBA at the edge of the ROW. This criterion has been interpreted by the state and BPA to meet Oregon Noise Control Regulations (Perry, 1982). The Environmental Protection Agency (EPA) has established a guideline of 55 dBA for the annual average day-night level ( $L_{dn}$ ) in outdoor areas (EPA, 1978). In computing this value, a 10 dB correction (penalty) is added to night-time noise between the hours of 10 p.m. and 7 a.m.

## 7.2 Transmission-line Audible Noise

Corona is the partial electrical breakdown of the insulating properties of air around the conductors of a transmission line. In a small volume near the surface of the conductors, energy and heat are dissipated. Part of this energy is in the form of small local pressure changes that result in audible noise. Corona-generated audible noise can be characterized as a hissing, crackling sound that, under certain conditions, is accompanied by a 120-Hz hum.

Corona-generated audible noise is of concern primarily for contemporary lines operating at voltages of 345 kV and higher during foul weather. Thus in the area where the proposed 230-kV line parallels a 500-kV line, audible noise from the higher voltage line will predominate. In other areas, the proposed 230-kV line will produce some noise under foul-weather conditions.

The conductors of high-voltage transmission lines are designed to be corona-free under ideal conditions. However, protrusions on the conductor surface—particularly water droplets on or dripping off the conductors—cause electric fields near the conductor surface to exceed corona onset levels, and corona occurs. Therefore, audible noise from transmission lines is generally a foul-weather (wet-conductor) phenomenon. Wet conductors can occur during periods of rain, fog, snow, or icing. Based on meteorologic records near the route of the proposed transmission line, such conditions are expected to occur less than 22% of the time during the year. For a few months after line construction, residual grease or oil on the conductors can cause water to bead up on the surface. This results in more corona sources and slightly higher levels of audible noise and electromagnetic interference if the line is energized. However, the new conductors "age" in a few months, and the level of corona activity decreases to the predicted equilibrium value. During fair weather, insects and dust on the conductor can also serve as sources of corona. The proposed line has been designed with 1.600-in. (4.1-cm) diameter conductors that will yield acceptable corona levels.

## 7.3 Predicted Audible Noise Levels

The predicted levels of corona-generated audible noise for the proposed line operated at a voltage of 235 kV are given in Table 8. For comparison, Table 8 also gives the calculated levels for the existing lines. Audible noise levels are calculated for average voltage and average conductor heights for fair- and foul-weather conditions. The calculated median level ( $L_{50}$ ) during foul weather at the edge of the proposed Santiam - Bethel right-of-way is about 39 dBA, which is less than that from the existing Santiam - Chemawa 230-kV line. Where the proposed Santiam - Bethel line parallels the Marion - Santiam 500-kV line, noise from the higher-voltage line will predominate and there would be no change in noise levels from existing conditions. For this configuration, the noise at the edge of the right-of-way near the proposed line would be 47 dBA.

During fair-weather conditions, which occur about 78% of the time, audible noise levels at the edge of the right-of-way would be about 20 dBA lower (if corona were present). These lower levels could be masked by ambient noise on and off the right-of-way.



## 7.4 Discussion

The calculated foul-weather corona noise levels for the proposed line would be less than those under the existing conditions and comparable to or less than those from existing 230-kV lines in Oregon. During fair weather, noise from the conductors might be perceivable on the right-of-way, but beyond the right-of-way it would likely be masked or so low as to not be perceived even during foul weather when ambient noise is higher.

Off the right-of-way, the levels of audible noise from the proposed line would be well below the 55 dBA level that can produce interference with speech outdoors. Since residential buildings provide significant sound attenuation (-12 dBA with windows open; -24 dBA with windows closed), the noise levels off the right-of-way would be well below the 45 dBA level required for interference with speech indoors and well below the 35 dBA level where sleep interference can occur (EPA, 1973; EPA, 1978). Since corona is a foul-weather phenomenon, people tend to be inside with windows possibly closed, providing additional attenuation when corona noise is present. In addition, ambient noise levels can be high during such periods (due to rain hitting foliage or buildings), and can mask corona noise.

The 39-dBA and 47-dBA levels would meet the BPA design criterion and, hence, the Oregon Noise Control Regulations for transmission lines. The 2 dBA decrease in noise at the edge of the right-of-way associated with the proposed line would probably not be discernible.

The computed annual  $L_{dn}$  level for transmission lines operating in areas with about 22% foul weather is about  $L_{dn} = L_{50} + 1$  dB (Bracken, 1987). Therefore, assuming such conditions in the Santiam - Bethel area, the estimated  $L_{dn}$  at the edge of the right-of-way would be approximately 40 or 48 dBA, which is below the EPA  $L_{dn}$  guideline of 55 dBA.

## 7.5 Conclusion

Along the proposed line route, there would be slight decreases, or no change, in the perceived noise above ambient levels during foul weather at the edges of the right-of-way. Along the existing corridor, the corona-generated noise during foul weather would be masked to some extent by naturally occurring sounds such as wind and rain on foliage. During fair weather, the noise off the right-of-way from the proposed line would probably not be detectable above ambient levels. However, noise from the existing 500-kV line could be perceived as much as under existing conditions. The noise levels from the proposed line would be below levels identified as causing interference with speech or sleep. The audible noise from the transmission line would be below EPA guideline levels and would meet the BPA design criterion that complies with the Oregon State noise regulations.

## 8.0 Electromagnetic Interference

### 8.1 Basic Concepts

Corona on transmission-line conductors can also generate electromagnetic noise in the frequency bands used for radio and television signals. The noise can cause radio and television interference (RI and TVI). In certain circumstances, corona-generated electromagnetic interference (EMI) can also affect communications systems and other sensitive receivers. Interference with electromagnetic signals by corona-generated noise is generally associated with lines operating at voltages of 345 kV or higher. This is especially true of interference with television signals. The 1.600-in. (4.1-cm) diameter conductor used

in the design of the proposed 230-kV line will mitigate corona generation and thus keep radio and television interference levels at acceptable levels.

Spark gaps on distribution lines and on low-voltage wood-pole transmission lines are a more common source of RI/TVI than is corona from high-voltage electrical systems. This gap-type interference is primarily a fair-weather phenomenon caused by loose hardware and wires. The proposed transmission line would be constructed with modern hardware that eliminates such problems and therefore minimizes gap noise. Consequently, this source of EMI is not anticipated for the proposed line.

No state has limits for either RI or TVI. In the United States, electromagnetic interference from power transmission systems is governed by the Federal Communications Commission (FCC) Rules and Regulations presently in existence (FCC, 1988). A power transmission system falls into the FCC category of "incidental radiation device," which is defined as "a device that radiates radio frequency energy during the course of its operation although the device is not intentionally designed to generate radio frequency energy." Such a device "shall be operated so that the radio frequency energy that is emitted does not cause harmful interference. In the event that harmful interference is caused, the operator of the device shall promptly take steps to eliminate the harmful interference." For purposes of these regulations, harmful interference is defined as: "any emission, radiation or induction which endangers the functioning of a radio navigation service or of other safety services or seriously degrades, obstructs or repeatedly interrupts a radio communication service operating in accordance with this chapter" (FCC, 1988: Vol II, part 15. 47CFR, Ch. 1).

Electric power companies have been able to work quite well under the present FCC rule because harmful interference can generally be eliminated. It has been estimated that more than 95% of power-line sources that cause interference are due to gap-type discharges. These can be found and completely eliminated, when required to prevent interference (USDOE, 1980). Complaints related to corona-generated interference occur infrequently. This is especially true with the advent of cable television and satellite television, which are not subject to corona-generated interference. Mitigation of corona-generated interference with conventional radio and television receivers can be accomplished in several ways, such as use of a directional antenna or relocation of an existing antenna (USDOE, 1977; USDOE, 1980; Loftness et al., 1981).

## **8.2 Radio Interference (RI)**

Radio reception in the AM broadcast band (535 to 1605 kilohertz (kHz)) is most often affected by corona-generated EMI. FM radio reception is rarely affected. Generally, only residences very near to transmission lines can be affected by RI. The IEEE Radio Noise Design Guide identifies an acceptable limit of fair-weather RI as expressed in decibels above 1 microvolt per meter (dB $\mu$ V/m) of about 40 dB $\mu$ V/m at 100 ft. (30 m) from the outside conductor (IEEE Committee Report, 1971). As a general rule, average levels during foul weather (when the conductors are wet) are 16 to 22 dB $\mu$ V/m higher than average fair-weather levels.

## **8.3 Predicted RI Levels**

Table 9 gives the predicted fair- and foul-weather RI levels at 100 ft. (30 m) from the outside conductor for the proposed 230-kV line in the two corridor configurations. Median foul-weather levels would be about 17 dB higher than the fair-weather levels. The predicted L<sub>50</sub> fair-weather level at the edge of the right-of-way is 34 dB $\mu$ V/m for 235-kV line operation; at 100 ft. (30 m) from the outside conductor, the level is 26 dB $\mu$ V/m. Predicted fair-weather L<sub>50</sub> levels are lower than that from the existing 230-kV Santiam - Chemawa 230-kV line. Predictions indicate that fair-weather RI will meet the IEEE

40 dB $\mu$ V/m criterion at distances greater than about 10 ft. (3 m) from the outside conductor of the proposed line.

#### **8.4 Television Interference (TVI)**

Corona-caused TVI occurs during foul weather and is generally of concern for transmission lines with voltages of 345 kV or above, and only for conventional receivers within about 600 ft. (183 m) of a line. As is the case for RI, gap sources on distribution and low-voltage transmission lines are the principal observed sources of TVI. The use of modern hardware and construction practices for the proposed line would minimize such sources.

#### **8.5 Predicted TVI Levels**

Table 10 shows TVI levels predicted at 100 ft. (30 m) from the outside conductor of the proposed line operating at 235 kV and from existing lines. At this distance, the foul-weather TVI level predicted for the proposed line is 10 dB $\mu$ V/m. This level is lower than that from the existing Santiam - Chemawa 230-kV line. Replacement of the existing line with the proposed line will reduce TVI levels along the right-of-way.

Other forms of TVI from transmission lines are signal reflection (ghosting) and signal blocking caused by the relative locations of the transmission structure and the receiving antenna with respect to the incoming television signal. The proposed structures are steel and larger than the existing wood structures; they could cause reflection or ghosting and affect reception in rare instances. Television systems that operate at higher frequencies, such as satellite receivers, are not affected by corona-generated TVI. Cable television systems are similarly unaffected.

Interference with television reception can be corrected by any of several approaches: improving the receiving antenna system; installing a remote antenna; installing an antenna for TV stations less vulnerable to interference; connecting to an existing cable system; or installing a translator (cf. USDOE, 1977). BPA has an active program to identify, investigate, and mitigate legitimate RI and TVI complaints. It is anticipated that any instances of TVI caused by the proposed line could be effectively mitigated.

#### **8.6 Interference with Other Devices**

Corona-generated interference can conceivably cause disruption on other communications bands such as the citizen's (CB) and mobile bands. However, mobile-radio communications are not susceptible to transmission-line interference because they are generally frequency modulated (FM). Similarly, cellular telephones operate at a frequency of about 900 MHz, which is above the frequency where corona-generated interference is prevalent. In the unlikely event that interference occurs with these or other communications, mitigation can be achieved with the same techniques used for television and AM radio interference. However, the addition of the proposed line would lower interference levels in the corridor; consequently, no impact is anticipated.

#### **8.7 Conclusion**

Predicted EMI levels for the proposed 230-kV transmission line are lower than those that already exist 230-kV lines; no impacts of corona-generated interference on radio, television, or other reception are anticipated above those already present. Furthermore, if interference should occur, there are various methods for correcting it: BPA has a program to respond to legitimate complaints.

## 9.0 Other Corona Effects

Corona is visible as a bluish glow or as bluish plumes. On the proposed 230-kV line, corona levels would be very low, so that corona on the conductors would be observable only under the darkest conditions and only with the aid of binoculars, if at all. Without a period of adaptation for the eyes and without intentional looking for the corona, it would not be noticeable.

When corona is present, the air surrounding the conductors is ionized and many chemical reactions take place, producing small amounts of ozone and other oxidants. Ozone is approximately 90% of the oxidants, while the remaining 10% is composed principally of nitrogen oxides. The national primary ambient air quality standard for photochemical oxidants, of which ozone is the principal component, is 235 micrograms/cubic meter) or 120 parts per billion. The maximum incremental ozone levels at ground level produced by corona activity on the proposed transmission line during foul weather would be much less than 1 part per billion. This level is insignificant when compared with natural levels and fluctuations in natural levels.

## 10.0 Summary

Electric and magnetic fields from the proposed transmission line have been characterized using well-known techniques accepted within the scientific and engineering community. The expected electric-field levels from the proposed line at minimum design clearance would be less than those from the existing line in the corridor and comparable to, or less than, those from other 230-kV lines in Oregon and elsewhere. The expected magnetic-field levels from the proposed line would be less than those from the existing line that would be replaced and comparable to, or less than, those from other 230-kV lines in Oregon and elsewhere.

The peak electric field expected under the proposed line would be 2.5 kV/m; the maximum value at the edge of the right-of-way would be about 0.4 kV/m. Clearances at road crossings would be increased to reduce the peak electric-field value to 1.7 kV/m.

Under maximum current conditions, the maximum magnetic fields under the proposed line would be 96 mG; at the edge of the right-of-way nearest to the proposed 230-kV line, the magnetic field would be 29 or 26 mG, depending on whether the line parallels an existing 500-kV line or not.

The electric and magnetic fields from the proposed line would meet regulatory limits for public exposure in Oregon and other states with limits. As long as cardiac pacemaker wearers are discouraged from using the right-of-way, the field levels meet the guidelines for exposure established by ACGIH and ICNIRP.

Short-term effects from transmission-line fields are well understood and can be mitigated. Nuisance shocks arising from electric-field induced currents and voltages could be perceivable on the right-of-way of the proposed line. BPA will ground permanent conducting objects during and after construction to mitigate against such occurrences. Since the fields from the proposed line are less than those from the existing line on the corridor, the potential for such effects could be reduced.

Corona-generated audible noise from the line would be less than from the existing 230-kV transmission lines on the corridor. Audible noise levels would be in compliance with noise regulations in Oregon and would be below levels specified in EPA guidelines.

Corona-generated electromagnetic interference from the proposed line would be less than that from the existing 230-kV line on the corridor and would remain below limits identified as acceptable. In the unlikely event that legitimate complaints arise, BPA has a mitigation program to identify and correct reception problems.

## List of References Cited

- ACGIH (American Conference of Governmental Industrial Hygienists). 2000. 2000 TLVs and BEIs: Threshold Limit Values for Chemical Substances and Physical Agents and Biological Exposure Indices. American Conference of Governmental Industrial Hygienists, Cincinnati. 192 pages.
- Baishiki, R.S.; Johnson, G.B.; Zaffanella, L.E.; Bracken, T.D.; Sussman, S.S.; Rauch, G.B.; and Silva, J.M. 1990. Studies of Power System Magnetic Fields: Characterization of Sources in Residential Environments, Measurement of Exposure, Influence On Computer Screens. (36-104) CIGRE, Paris, France. 10 pages.
- Banfai, B.; Karady, G.G.; Kim, C.J.; and Maracas, K.B. 2000. Magnetic field effects on CRT computer monitors. *IEEE Trans. on Power Delivery* 15, 307-312.
- Bassen, H.; Casamento, J.; and Crawl, B. 1991. Reduction of electric and magnetic field emissions from electric blankets (Meeting abstract). *In: Bioelectromagnetics Society, 13th Annual Meeting, 23-27 June, Salt Lake City. Bioelectromagnetics Society, New York, 20.*
- Bowman, J.D.; Garabrant, D.H.; Sobel, E.; and Peters, J.M. June 1988. Exposures to Extremely Low Frequency (ELF) Electromagnetic Fields in Occupations With Elevated Leukemia Rates. *Applied Industrial Hygienics*, 3(6, June):189-194.
- Bracken, T.D. 1987. Audible Noise from High Voltage Transmission Facilities. A Briefing Paper Prepared for State of Florida Department of Environmental Regulation. (DER Contract No. SP122) State of Florida Department of Environmental Regulation.
- Bracken, T.D. 1990. The EMDEX Project: Technology Transfer and Occupational Measurements, Volumes 1-3 Interim Report. EPRI Report EN-7048. (EPRI EN-7048) Electric Power Research Institute, Palo Alto, CA.
- Chartier, V.L. April 1983. Empirical Expressions for Calculating High Voltage Transmission Corona Phenomena, First Annual Seminar Technical Career Program for Professional Engineers. Bonneville Power Administration, Portland, Oregon. April 1983, 75-82.
- Chartier, V.L.; and Stearns, R.D. January 1981. Formulas for Predicting Audible Noise from Overhead High Voltage AC and DC Lines. *IEEE Transactions on Power Apparatus and Systems*, PAS-100(No. 1, January 1981):121-129.
- Dabkowski, J.; and Taflove, A. May/June 1979. Prediction Method for Buried Pipeline Voltages Due to 60 Hz AC Inductive Coupling. Part II: Field Test Verification. *IEEE Transactions on Power Apparatus and Systems*, PAS-98(3, May/June):788-794.
- Deno, D.W.; and Zaffanella, L. 1982. Field effects of overhead transmission lines and stations. Chap. 8. *In: Transmission Line Reference Book: 345 KV and Above. Second ed. (Ed: LaForest, J.J.). Electric Power Research Institute, Palo Alto, CA, 329-419.*
- EPA (Environmental Protection Agency). July 1973. Public Health and Welfare Criteria for Noise. (No. 500/9-73-002, July 27, 1973.) U.S. Environmental Protection Agency, Washington, D.C.

- EPA. 1974. Information On Levels of Environmental Noise Requisite to Protect Public Health and Welfare With an Adequate Margin of Safety. (No. PB-239 429.) U.S. Environmental Protection Agency, Washington, D.C.
- EPA. 1978. Protective Noise Levels. Condensed Version of EPA Levels Document. (No. PB82-138827) U.S Environmental Protection Agency, Washington, DC.
- FCC (Federal Communications Commission). 1988. Federal Communications Commission Rules and Regulations. 10-1-88 ed. Vol. II part 15, 47 CFR, Ch. 1.
- Florig, H.K.; and Hoburg, J.F. 1988. Electric and Magnetic Field Exposure Associated With Electric Blankets. Project Resume. Contractor's Review. U.S. Department of Energy/Electric Power Research Institute.
- Florig, H.K.; Hoburg, J.F.; and Morgan, M.G. April 1987. Electric Field Exposure from Electric Blankets. IEEE Transactions on Power Delivery, PWRD-2(2, April):527-536.
- Gauger, J. September 1985. Household Appliance Magnetic Field Survey. IEEE Transactions on Power Apparatus and Systems, 104(9, September):2436-2445.
- Harvey, S.M. 1983. Analysis of operator exposure to electric fields from video display units. Chap. 2. In Video Display Units--Characterization of Electric and Magnetic Fields. (Ontario Hydro Research Division Report # 83-503-K) (Ed: Walsh, M.L.). Ontario Hydro, Toronto, 31-56.
- Heroux, P. 1987. 60-Hz Electric and Magnetic Fields Generated By a Distribution Network. Bioelectromagnetics, 8(2):135-148.
- ICNIRP (International Committee on Non-ionizing Radiation Protection). April 1998. Guidelines for Limiting Exposure to Time-Varying Electric, Magnetic, and Electromagnetic Fields (Up to 300 GHz). Health Physics, 74(4, April):1-32.
- IEEE (Institute of Electrical and Electronics Engineers, Inc.). 1978. Electric and Magnetic Field Coupling from High Voltage AC Power Transmission Lines -- Classification of Short-Term Effects On People. IEEE Transactions on Power Apparatus and Systems, PAS-97:2243-2252.
- IEEE. 1987. IEEE Standard Procedures for Measurement of Power Frequency Electric and Magnetic Fields from AC Power Lines. ANSI/IEEE Std. 644-1987, New York, NY.
- IEEE. 1990. National Electrical Safety Code. 1990 ed. Institute of Electrical and Electronics Engineers, Inc., New York, NY. 432 pages.
- IEEE Committee Report. March/April 1971. Radio Noise Design Guide for High Voltage Transmission Lines. IEEE Transactions on Power Apparatus and Systems, PAS-90(No. 2, March/April):833-842.
- IEEE Committee Report. October 1982. A Comparison of Methods for Calculating Audible Noise of High Voltage Transmission Lines. IEEE Transactions on Power Apparatus and Systems, 101(10, October):4090-4099.
- ITT Research Institute. 1984. Representative Electromagnetic Field Intensities Near the Clam Lake (WI) and Republic (MI) ELF Facilities. Report Prepared for Naval Electronics Systems

- Command, PME 110 E Washington, D.C. 20360. (Under contract N00039-84-C0070.) ITT Research Institute, Chicago, IL. 60 pages.
- Jaffa, K.C.; and Stewart, J.B. March 1981. Magnetic Field Induction from Overhead Transmission and Distribution Power Lines On Buried Irrigation Pipelines. *IEEE Transactions on Power Apparatus and Systems*, PAS-100(3, March):990-1000.
- Keeseey, J.C.; and Letcher, F.S. 1969. Minimum Thresholds for Physiological Responses to Flow of Alternating Electric Current Through the Human Body At Power-Transmission Frequencies. (Report No. 1) Naval Medical Research Institute, Project MR 005.08-0030B, Bethesda, MD. 25 pages.
- Loftness, M.O.; Chartier, V.L.; and Reiner, G.L. 1981. EMI Correction Techniques for Transmission Line Corona. (August 18-20, 1981, pp. 351-361.) Proceedings of the 1981 IEEE International Symposium on Electromagnetic Compatibility, Boulder, CO.
- Maddock, B.J. September 1992. Guidelines and Standards for Exposure to Electric and Magnetic Fields At Power Frequencies. (Panel 2-05, CIGRE meeting August 30-September 5, 1992) CIGRE, Paris.
- Olsen, R.G.; Schennum, S.D.; and Chartier, V.L. April 1992. Comparison of Several Methods for Calculating Power Line Electromagnetic Interference Levels and Calibration With Long Term Data. *IEEE Transactions on Power Delivery*, 7(April, 1992):903-913.
- Oregon, State of. 1980. Oregon Administrative Rules Chapter 345, Division 80. Energy Facility Siting Council standards relating to public health and safety, 934-80-055.
- Perry, D. 1982. Sound Level Limits from BPA Facilities. BPA memorandum, May 26, 1982; Department of Environmental Quality, Noise Control Regulations, Chapter 340, Oregon Administrative Rules, Division 35, March 1, 1978.
- Reilly, J.P. 1979. Electric Field Induction on Long Objects—A Methodology for Transmission Line Impact Studies. *IEEE Transactions on Power Apparatus and Systems*, PAS-98(6, Nov/Dec):1841-1852.
- Sheppard, A.R.; and Eisenbud, M. 1977. Biological Effects of Electric and Magnetic Fields of Extremely Low Frequency. New York University Press, New York.
- Silva, M.; Hummon, N.; Rutter, D.; and Hooper, C. 1989. Power Frequency Magnetic Fields in the Home. *IEEE Transactions on Power Delivery*, 4:465-478.
- Stoppa, G.J.; and Janischewskyj, W. 1979. Epidemiological Study of Workers Maintaining HV Equipment and Transmission Lines in Ontario. (Canadian Electrical Association Research Report) Canadian Electrical Association, Montreal. 82 pages.
- Taflove, A.; and Dabkowski, J. May/June 1979. Prediction Method for Buried Pipeline Voltages Due to 60 Hz AC Inductive Coupling. Part I: Analysis. *IEEE Transactions on Power Apparatus and Systems*, PAS-98(3, May/June):780-787.



- TDHS Report. March 1989. EMF Rule Becomes Law; Hillsborough County Commission Challenges. Transmission/Distribution Health & Safety Report, 7(9, 31 March):1-3.
- TDHS Report. August 1990. Updates: New York. Transmission/Distribution Health & Safety Report, 8(7, 31 August):4.
- USDOE (U.S. Department of Energy), Bonneville Power Administration. March 1977. A Practical Handbook for the Location, Prevention and Correction of Television Interference from Overhead Power Lines. Portland, OR.
- USDOE, Bonneville Power Administration. May 1980. A Practical Handbook for the Correction of Radio Interference from Overhead Powerlines and Facilities. (May 1980.) Portland, OR.
- USDOE, Bonneville Power Administration. 1995. Living and Working Around High-Voltage Power Lines. (DOE/BP-799). Portland, OR. 9 pages.
- USDOE, Bonneville Power Administration. 1996. Electrical and Biological Effects of Transmission Lines: A Review. (DOE/BP 2938 December 1996 1M) Portland, OR.
- USDOE, Bonneville Power Administration. undated. "Corona and Field Effects" Computer Program (Public Domain Software). Bonneville Power Administration, P.O. Box 491-ELE, Vancouver, WA 98666.
- Zaffanella, L.E. 1993. Survey of Residential Magnetic Field Sources. Vol. 1: Goals, results, and conclusions. (EPRI TR-102759-V1, Project 3335-02) Electric Power Research Institute, Palo Alto, CA.
- Zaffanella, L.E.; and Kalton, G.W. 1998. Survey of personal magnetic field exposure, Phase II: 1000-person survey. Interim Report. EMF RAPID Program Engineering Project #6. Eneritech Consultants, Lee, MA.

## **List of Preparers**

T. Dan Bracken was the principal author of this report. He received a B.S. degree in physics from Dartmouth College and M.S. and Ph.D. degrees in physics from Stanford University. Dr. Bracken has been involved with research on and characterization of electric- and magnetic-field effects from transmission lines for over 27 years, first as a physicist with the Bonneville Power Administration (BPA) (1973 - 1980) and since then as a consultant. His firm, T. Dan Bracken, Inc., offers technical expertise in areas of electric- and magnetic-field measurements, instrumentation, environmental effects of transmission lines, exposure assessment and project management. Joseph Dudman of T. Dan Bracken, Inc., provided data entry, graphics, and clerical support in the preparation of the report.

Judith H. Montgomery of Judith H. Montgomery/Communications served as technical editor for the report. She holds an A.B. degree in English literature from Brown University, 1966; and a Ph.D. degree in American literature from Syracuse University, 1971. Dr. Montgomery has provided writing, editing, and communications services to government and industry for 20 years. Her experience includes preparation of National Environmental Policy Act documents and technical papers dealing with transmission-line environmental impact assessment and other utility-related activities.

(This page intentionally left blank.)

**Table 1: Physical and electrical characteristics of Santiam - Bethel Project corridors**

	New Line	Existing Corridors	
Configuration	I	I	II
Description	Santiam - Bethel/Santiam - Chemawa 230-kV	Santiam - Chemawa 230-kV	Marion - Santiam No. 1 & No. 2 500-kV
Voltage, kV Maximum/Average <sup>1</sup>	242/235	242/235	550/540, 0/0
Peak Current, A Existing/Proposed	-/755, -/644	1043/-	-889/-992, 0/0
Electric Phasing	B C A B C A	C B A	B B A C A C
Clearance, ft. Minimum/Average <sup>1</sup>	31/43	31/43	38/47
Centerline Distance from Santiam - Bethel, ft.	-	-	125
Centerline distance to edge of right-of-way (ROW), ft.	62.5	62.5	82.5
Tower configuration	Vertical double-circuit	Horizontal	Delta double-circuit
Phase spacing, ft.	24.5H, 40.5H 18V	27H	25.5H, 36.75V
Conductor: #/Diameter, in.	1/1.600	1/1.100	3/1.302

<sup>1</sup> Average voltage and average clearance used for corona calculations.

**Table 2: Possible corridors for Santiam - Bethel Project**

Configuration	Description of other lines in corridor with Santiam - Bethel/Santiam - Chemawa 230-kV line	Miles
I	Santiam - Bethel/Santiam - Chemawa 230-kV double-circuit line only	15.2
II	BPA Marion - Santiam 500-kV No. 1 and No. 2 double circuit line	1.5

**Table 3: Calculated electric fields for configurations of the proposed Santiam - Bethel/Santiam - Chemawa 230-kV line operated at maximum voltage.** Configurations are described in Tables 1 and 2.

a) **Configuration I: Santiam - Bethel/Santiam - Chemawa 230-kV line only**

Configuration	Proposed I		Existing	
ROW width, ft. (m)	125 (38)		125 (38)	
Line	Santiam - Bethel/Santiam - Chemawa 230-kV		Santiam - Chemawa 230-kV	
Clearance	Min.	Avg.	Min.	Avg.
Peak field, kV/m	2.5	1.5	3.0	1.8
Edge of ROW, kV/m	0.3	0.4	1.3	1.1

b) **Configuration II: Santiam - Bethel/Santiam - Chemawa 230-kV and Marion - Santiam 500-kV No. 1 and No. 2 lines**

Configuration	Proposed II				Existing			
ROW width, ft. (m)	270 (82)				270 (82)			
Line	Santiam - Bethel/ Santiam - Chemawa 230-kV		Marion - Santiam No. 1 and No. 2 500-kV		Santiam - Chemawa 230-kV		Marion - Santiam No. 1 and No. 2 500-kV	
Clearance	Min.	Avg.	Min.	Avg.	Min.	Avg.	Min.	Avg.
Peak field, kV/m	2.4	1.4	8.1	4.5	3.0	1.8	8.1	4.5
Edge of ROW, kV/m	0.3	0.3	2.5	2.6	1.3	1.1	2.5	2.6

**Table 4: Calculated magnetic fields for configurations of the proposed Santiam - Bethel/Santiam - Chemawa 230-kV line operated at maximum current.** Configurations are described in Tables 1 and 2.

a) **Configuration I: Santiam - Bethel/Santiam - Chemawa 230-kV line only**

Configuration	Proposed I		Existing	
ROW width, ft. (m)	125 (38)		125 (38)	
Line	Santiam - Bethel/Santiam - Chemawa 230-kV		Santiam - Chemawa 230-kV	
Clearance	Min.	Avg.	Min.	Avg.
Peak field, mG	87	50	218	139
Edge of ROW, mG	26	24	78	62

b) **Configuration II: Santiam - Bethel/Santiam - Chemawa 230-kV and Marion - Santiam 500-kV No. 1 and No. 2 lines**

Configuration	Proposed II				Existing			
ROW width, ft. (m)	270 (82)				270 (82)			
Line	Santiam - Bethel/ Santiam - Chemawa 230-kV		Marion - Santiam No. 1 and No. 2 500-kV		Santiam - Chemawa 230-kV		Marion - Santiam No. 1 and No. 2 500-kV	
Clearance	Min.	Avg.	Min.	Avg.	Min.	Avg.	Min.	Avg.
Peak field, mG	94	58	130	67	211	135	108	57
Edge of ROW, kV/m	29	24	52	39	80	65	50	38

**Table 5: States with transmission-line field limits**

STATE AGENCY	WITHIN RIGHT-OF- WAY	AT EDGE OF RIGHT-OF- WAY	COMMENTS
<b>a. 60-Hz ELECTRIC FIELD LIMIT, kV/m</b>			
Florida Department of Environmental Regulation	8 ( 230 kV) 10 (500 kV)	2	Codified regulation, adopted after a public rulemaking hearing in 1989.
Minnesota Environmental Quality Board	8	–	12-kV/m limit on the High-Voltage Direct Current (HVDC) nominal electric field.
Montana Board of Natural Resources and Conservation	7 <sup>1</sup>	1 <sup>2</sup>	Codified regulation, adopted after a public rulemaking hearing in 1984.
New Jersey Department of Environmental Protection	–	3	Used only as a guideline for evaluating complaints.
New York State Public Service Commission	11.8 (7,11) <sup>1</sup>	1.6	Explicitly implemented in terms of a specified right-of-way width.
Oregon Facility Siting Council	9	–	Codified regulation, adopted after a public rulemaking hearing in 1980.
<b>b. 60-Hz MAGNETIC FIELD LIMIT, mG</b>			
Florida Department of Environmental Regulation	–	150 ( 230 kV) 200 (500 kV)	Codified regulations, adopted after a public rulemaking hearing in 1989.
New York State Public Service Commission	–	200	Adopted August 29, 1990.

- 1 At road crossings
- 2 Landowner may waive limit

Sources: TDHS Report, 1989;TDHS Report, 1990

**Table 6: Common noise levels**

Sound Level, dBA	Noise Source or Effect
128	Threshold of pain
108	Rock-and-roll band
80	Truck at 50 ft. (15.2 m)
70	Gas lawnmower at 100 ft. (30 m)
60	Normal conversation indoors
50	Moderate rainfall on foliage
50	Edge of 500-kV right-of-way during rain
40	Refrigerator
25	Bedroom at night
0	Hearing threshold

Adapted from: USDOE, 1996.

**Table 7: Typical sound attenuation (in decibels) provided by buildings**

	Windows opened	Windows closed
<b>Warm climate</b>	12	24
<b>Cold climate</b>	17	24

Source: EPA, 1978.



**Table 8: Predicted foul-weather audible noise (AN) levels at edge of right-of-way (ROW) for proposed Santiam - Bethel/Santiam - Chemawa 230-kV line.** AN levels expressed in decibels on the A-weighted scale (dBA). L<sub>50</sub> and L<sub>5</sub> denote the levels exceeded 50 and 5 percent of the time, respectively. For the parallel-line configurations<sup>1</sup>, the AN level at the edge of the proposed Santiam - Bethel ROW is given first.

Configuration <sup>1</sup>	Foul-weather AN					
	Proposed			Existing		
	ROW ft. (m)	L <sub>50</sub> , dBA	L <sub>5</sub> , dBA	ROW ft. (m)	L <sub>50</sub> , dBA	L <sub>5</sub> , dBA
I	125 (38)	39	43	125 (38)	41	44
II	270 (82)	47, 52	51, 55	270 (82)	47, 52	51, 55

1 Configurations are described in Tables 1 and 2.

**Table 9: Predicted fair-weather radio interference (RI) levels at 100 feet (30.5 m) from the outside conductor of the proposed Santiam - Bethel/Santiam - Chemawa 230-kV line.** RI levels given in decibels above 1 microvolt/meter (dBμV/m) at 1.0 MHz. L<sub>50</sub> denotes level exceeded 50 percent of the time. For the parallel-line configurations the RI level on the side of the proposed Santiam - Bethel ROW is given first.

Configuration <sup>1</sup>	Fair-weather RI	
	Proposed	Existing
	L <sub>50</sub> , dBμV/m	L <sub>50</sub> , dBμV/m
I	26	28
II	30, 41	30, 41

1 Configurations are described in Tables 1 and 2.

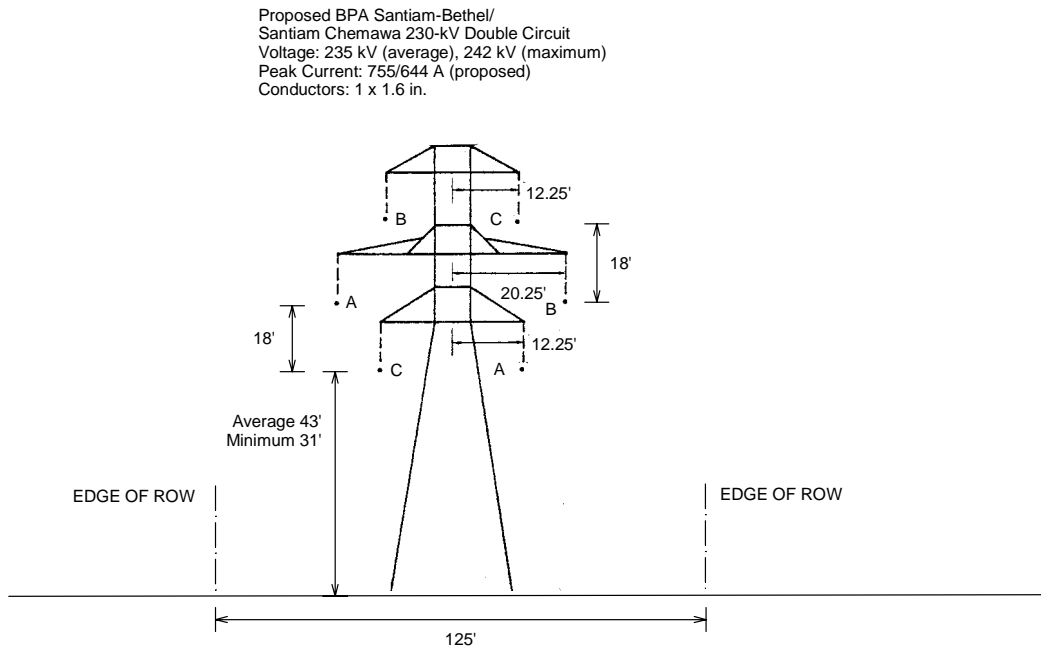
**Table 10: Predicted maximum foul-weather television interference (TVI) levels predicted at 100 feet (30.5 m) from the outside conductor of the proposed Santiam - Bethel/Santiam - Chemawa 230-kV line.** TVI levels given in decibels above 1 microvolt/meter (dB $\mu$ V/m) at 75 MHz. For the parallel-line configurations, the TVI level on the side of the proposed Santiam - Bethel ROW is given first.

<b>Configuration<sup>1</sup></b>	<b>Foul-weather TVI</b>	
	<b>Proposed</b>	<b>Existing</b>
	<b>L<sub>5</sub> (foul), dB<math>\mu</math>V/m</b>	<b>L<sub>5</sub> (foul), dB<math>\mu</math>V/m</b>
<b>I</b>	10	15
<b>II</b>	12, 27	15, 27

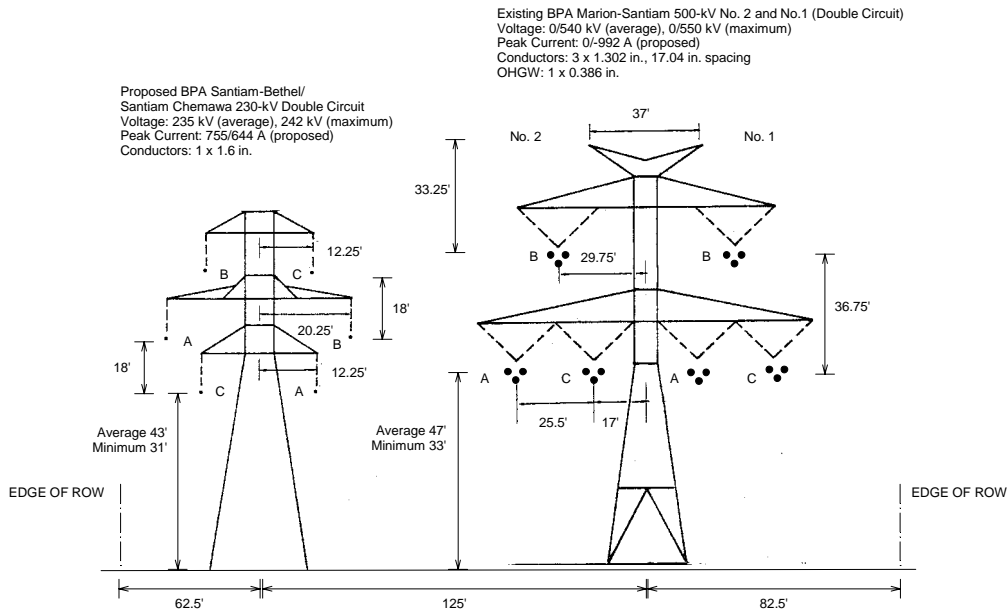
1 Configurations are described in detail in Tables 1 and 2.

**Figure 1: Configurations for proposed Santiam - Bethel/Santiam - Chemawa 230-kV line: a) proposed line with no parallel lines ( Configuration I); and b) proposed line with parallel 500-kV line (Configuration II).**

a) Proposed line with no parallel lines (Configuration I) (not to scale)

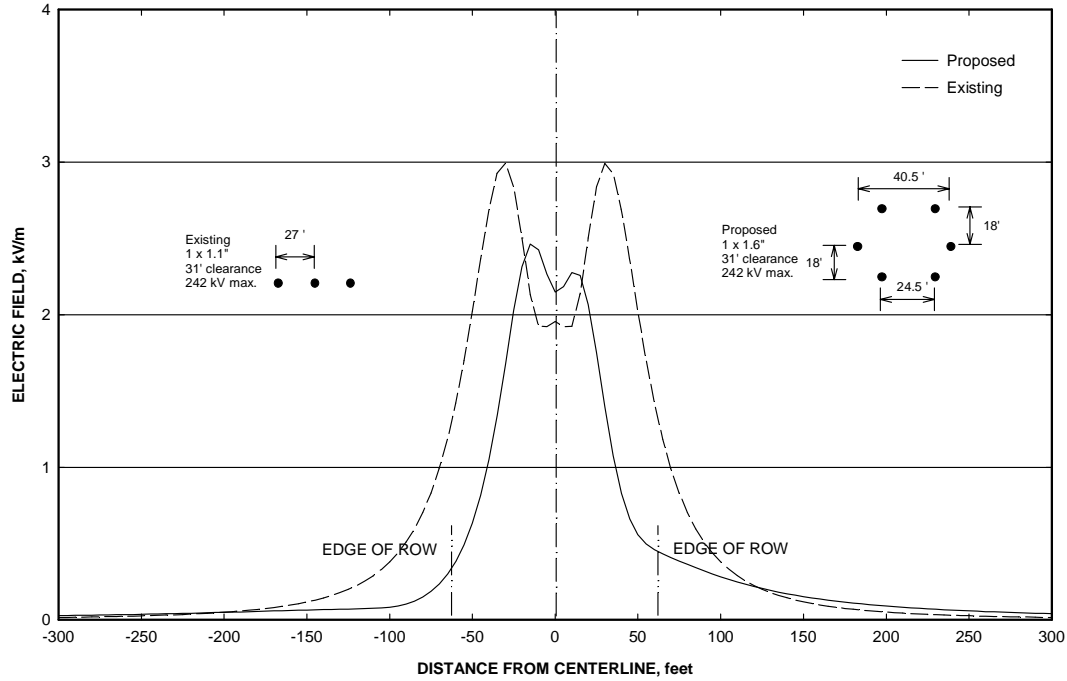


b) Proposed line with parallel 500-kV line (Configuration II) (not to scale)

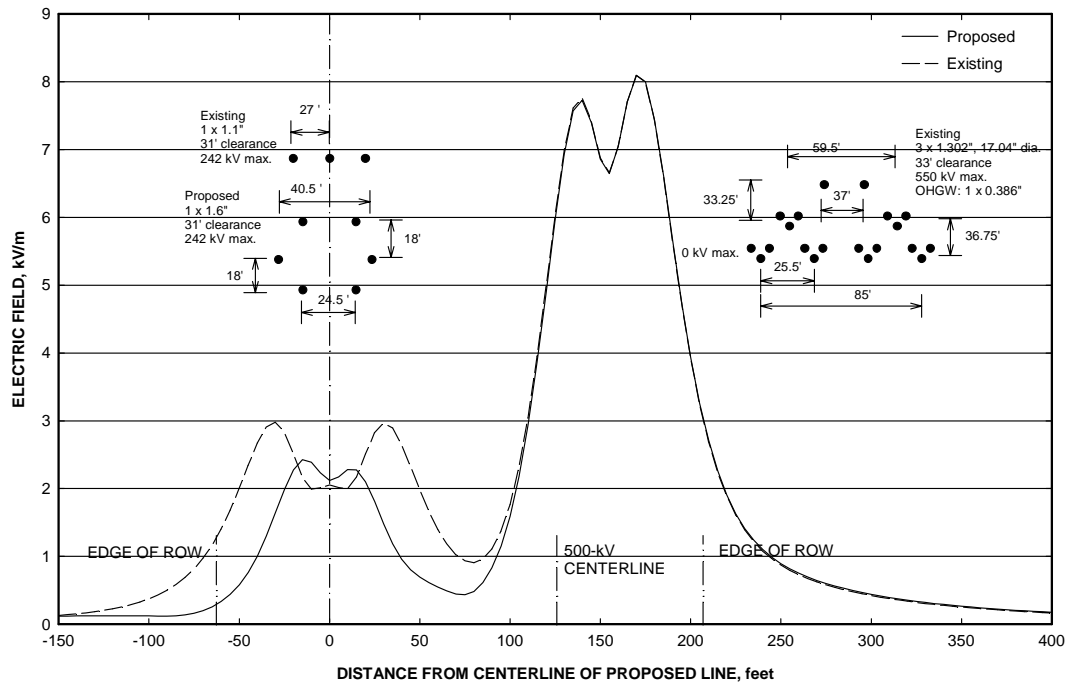


**Figure 2: Electric-field profiles for configurations of proposed Santiam - Bethel/Santiam - Chemawa 230-kV line: a) proposed line with no parallel line (Configuration I); and b) proposed line with parallel 500-kV line (Configuration II). Fields for maximum voltage and minimum clearances are shown.**

a) Proposed line with no parallel line (Configuration I).

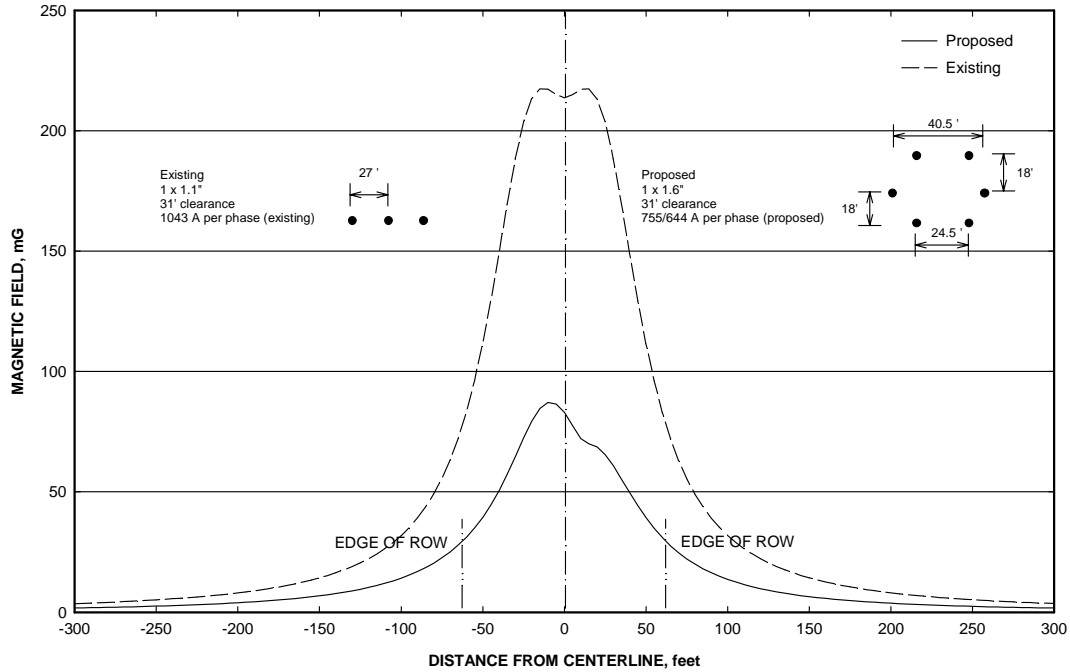


b) Proposed line with parallel 500-kV line (Configuration II)

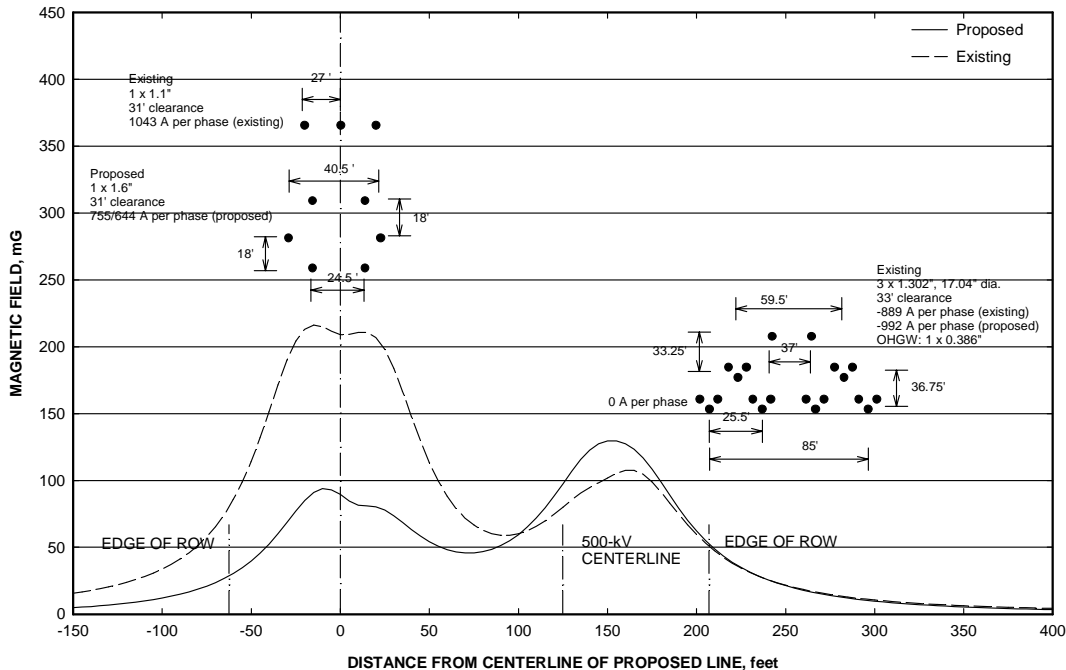


**Figure 3: Magnetic-field profiles for configurations of the proposed Santiam - Bethel/Santiam - Chemawa 230-kV line for maximum current conditions: a) proposed line with no parallel line (Configuration I); and b) proposed line with parallel 500-kV line (Configuration II).**

a) Proposed line with no parallel line (Configuration I)



b) Proposed line with parallel 500-kV line (Configuration II).



**SANTIAM-BETHEL TRANSMISSION PROJECT**

**APPENDIX B:**

**ASSESSMENT OF RESEARCH REGARDING EMF AND  
HEALTH AND ENVIRONMENTAL EFFECTS**

June 2001

Prepared by

**Exponent™**

and

**T. Dan Bracken, Inc.**

for

**Bonneville Power Administration**



## **Table of Contents**

1.0	Introduction .....	1
2.0	Health .....	1
2.1	The NIEHS Report and Research Program.....	1
2.2	Update of Research Related to Cancer.....	2
2.2.1	Epidemiology Studies of Children .....	2
2.2.2	Epidemiology Studies of Adults .....	5
2.2.3	Laboratory Studies of EMF.....	6
2.2.4	Summary Regarding Cancer .....	7
2.3	Research Related to Reproduction .....	7
2.4	Other Recent Reviews by Scientific Advisory Groups .....	7
2.4.1	National Radiological Protection Board of Great Britain (NRPB) Advisory Group on Non-Ionising Radiation .....	8
2.4.2	Health Council of the Netherlands.....	8
2.4.3	Institution of Electrical Engineers (IEE) of Great Britain.....	9
3.0	Ecological Research.....	9
3.1	Fauna.....	9
3.2	Flora .....	11
3.3	Summary .....	11
	LIST OF REFERENCES .....	12
	LIST OF PREPARERS .....	17





# **APPENDIX B: ASSESSMENT OF RESEARCH REGARDING EMF AND HEALTH AND ENVIRONMENTAL EFFECTS**

## **1.0 Introduction**

Over the last 20 years, research has been conducted in the United States (U.S.) and around the world to examine whether exposures to electric and magnetic fields (EMF) at 50/60 hertz (Hz) from electric power lines are a cause of cancer, or adversely affect human health. The research included epidemiology studies that suggested a link with childhood for some types of exposures, as well as other epidemiology studies that did not; it also included lifetime animal studies, which showed no evidence of adverse health effects. Comprehensive reviews of the research conducted by governmental and scientific agencies in the U.S. and in the United Kingdom (UK) had examined the research, and did not find a basis for imposing additional restrictions (NIEHS, 1999; IEE, 2000).

The Bonneville Power Administration (BPA) requested that Exponent update the BPA on research on EMF and health and in relation to exposures that might occur near the Bethel-Santiam Transmission Project.

This update concentrates on recent major research studies to explain how they contribute to the assessment of effects of EMF on health (Section 2). The focus is on both epidemiologic and laboratory research, because these research approaches provide different and complementary information for determining whether an environmental exposure can affect human health. Section 3, Ecological Research, reviews studies of potential effects of EMF on plants and animals in the natural environment. No additional studies of environmental effects were found in our search of the scientific literature through May 2001.

## **2.0 Health**

### **2.1 The NIEHS Report and Research Program**

In 1998, the NIEHS completed a comprehensive review of the scientific research on health effects of EMF. The NIEHS had been managing a research program that Congress funded in 1996, in response to questions regarding exposure to EMF from power sources. The program was known as the RAPID Program (Research and Public Information Dissemination Program). The NIEHS convened a panel of scientists (the “Working Group”) to review and evaluate the RAPID Program research and other research. Their report, *Assessment of Health Effects from Exposure to Power-Line Frequency Electric and Magnetic Fields*, was completed in July 1998 (NIEHS, 1998).

The director of the NIEHS prepared a health risk assessment of EMF and submitted his report to Congress in June 1999 (NIEHS, 1999). Experts at NIEHS, who had considered the previous Working Group report, reports from four technical workshops, and research that became available after June 1998, concluded as follows:

The scientific evidence suggesting that ELF-EMF [extremely low frequency-electric and magnetic field] exposures pose any health risk is weak. The strongest evidence for health

effects comes from associations observed in human populations with two forms of cancer: childhood leukemia and chronic lymphocytic leukemia in occupationally exposed adults. . . . In contrast, the mechanistic studies and animal toxicology literature fail to demonstrate any consistent pattern . . . . No indication of increased leukemias in experimental animals has been observed. . . . The lack of consistent, positive findings in animal or mechanistic studies weakens the belief that this association is actually due to ELF-EMF, but it cannot completely discount the epidemiology findings. . . . The NIEHS does not believe that other cancers or other non-cancer health outcomes provide sufficient evidence of a risk to currently warrant concern (pp. 9-10).

Although the results of the RAPID research are described in some detail in the 1998 report, many of the studies had not been published in the peer-reviewed literature. Recognizing the need to have these results reviewed and considered for publication, the NIEHS arranged for a special edition of the journal *Radiation Research* (*Radiation Research*, 153(5), 2000) to be devoted to this topic.<sup>1</sup>

## **2.2 Update of Research Related to Cancer**

This update includes studies of residential or occupational exposures to EMF and leukemia that became available this year (2001), including several reports from the California Department of Health Services. That Department conducted a workshop in 1999 to discuss epidemiologic research on EMF and health. The reports presented at this workshop were published in January 2001 as a supplement to the journal, *Bioelectromagnetics*. Many of the papers were technical discussions of methodology issues in epidemiologic studies of EMF, including discussions of how better to understand the conflicting results reported in previous studies (Neutra and Del Pizzo, 2001). For example, one paper evaluated epidemiology studies to determine whether systematic errors occurred in selection of cases and controls, or measurement of exposure. Although such systematic errors, or bias, occurred in some studies, there was insufficient information to assess the effect on results (Wartenberg, 2001a). Other researchers discuss epidemiologic approaches to study how possible confounding factors, such as the age and type of home and traffic density, might affect the interpretation of studies of EMF and childhood cancer (Langholz, 2001; Reynolds et al., 2001).

For this update, we review papers from this workshop that provide new information or statistical analyses. Several of the studies are “meta-analyses,” an approach that incorporates statistical methods to analyze differences and aggregate the results of smaller studies. The section below includes a review of meta-analyses of the studies of childhood leukemia through 1999, and a meta-analysis of studies of breast cancer in adults (Erren, 2001).

### **2.2.1 Epidemiology Studies of Children**

The question of power lines and childhood cancer has been based on the assumption that the relevant exposure associated with power lines is the magnetic field, rather than the electric field. This assumption rests on the fact that electric fields are shielded from the interior of homes (where people spend the vast majority of their time) by walls and vegetation, while magnetic fields are not. The magnetic field in the vicinity of a power line results from the flow of current; higher currents result in higher levels of magnetic fields.

---

<sup>1</sup> See, for instance, the articles cited in the **List of References** under Balcer- Kubiczek, Boorman, Loberg, and Ryan.

Epidemiologic studies report results in the form of statistical associations. The term “statistical association” is used to describe the tendency of two things to be linked or to vary in the same way, such as level of exposure and occurrence of disease. However, statistical associations are not automatically an indication of cause and effect, because the interpretation of numerical information depends on the context, including (for example) the nature of what is being studied, the source of the data, how the data were collected, and the size of the study. The larger studies and more powerful studies of EMF have not reported convincing statistical associations between power lines and childhood leukemia (e.g., Linet et al., 1997; McBride et al., 1999; UKCCS, 1999). Despite the larger sample size, these studies usually had a limited number of cases exposed over 2 or 3 milligauss (mG).

### *Epidemiology studies*

The following discussion briefly describes major studies.

- A study from Germany included 502 children with leukemia and 1,289 control children (Schuz et al., 2001). Measurements of magnetic-field intensity (50 Hz) were taken for 24 hours in the child’s bedroom. The results were calculated for daytime or nighttime levels in the bedroom, rather than for the child’s overall 24-hour exposure. The authors report an association with leukemia for mean daytime magnetic-field exposures that might have been due to chance. They reported an association between mean nighttime magnetic-field levels and leukemia for the highest exposed group (4 mG or higher; 9 cases). The assessment of exposure by mean field levels in the bedroom did not link magnetic-field levels to any specific source. The authors note in their conclusions that “. . . fewer than one-third of all stronger magnetic fields were caused by high-voltage powerlines. . . .” (Schuz et al., 2001: 734).

Several aspects of the study detract from the validity of the results: the estimate included a broad margin of error because only a small number of cases was exposed at the higher levels, and many eligible cases and controls did not participate, which means that the responders may not represent the population and results could be biased. Another concern is that these magnetic field measurements were taken in 1997, long after the relevant exposure period for cases diagnosed in 1990-1994. Magnetic-field levels may have changed over time, as electricity usage changed.

- A study from British Columbia, Canada, included 462 children who had been diagnosed with leukemia and an equal number of children without leukemia for comparison (McBride et al., 1999). Magnetic-field exposure was assessed for each of the children in several ways: personal monitors were worn in a backpack for 48 hours, a monitor took measurements in the bedroom for 24 hours, the wiring outside the house was rated by potential exposure level (wire codes), and measurements were taken around the outside perimeter of the homes. (Wire codes are a method of estimating relative exposure intensity based on the configuration of the power lines.) Regardless of the method used to estimate magnetic-field exposure, the magnetic-field exposure of children who had leukemia was not greater than that of the children in the comparison group.
- A study conducted in Ontario, Canada reported on the magnetic-field exposure of a smaller group of children (Green et al., 1999a). No increased risk estimates were found with the average magnetic fields in the bedroom or the interior, or with any of the three methods of estimating exposure from wire-configuration codes. A still smaller group of 88 children with leukemia and their controls wore personal monitors to measure magnetic fields (Green et al., 1999b). Associations with magnetic fields were reported in some of the analyses, but most of the risk estimates had a broad margin of error, and major methodological problems in the study preclude any clear interpretation of the findings.

- The United Kingdom Childhood Cancer Study, the largest study to date, included a total of 1073 childhood leukemia cases (UKCCS, 1999). Exposure was assessed by spot measurements in the home (bedroom and family room) and school, and summarized by averaging these over time. No evidence was found to support the idea of an increased risk of leukemia from exposures to magnetic fields from power sources inside or outside of the home.
- The UKCCS investigators had obtained magnetic-field measurements on only a portion of the cases in their study (UKCCS, 1999). To obtain additional information, they used a method to assess exposure to magnetic fields without entering homes; they were thus able to analyze 50% more subjects (UKCCS, 2000). For all these children, they measured distances to power lines and substations. This information was used to calculate the magnetic field from these external field sources, based on power-line characteristics related to production of magnetic fields. The results of the second UKCCS study showed no evidence for an association with leukemia for magnetic fields calculated to be between 1 mG and 2 mG, 2 mG and 4 mG, or 4 mG or greater at the residence, in contrast to the weak association reported for measured fields of 4 mG or greater in the first report (UKCCS, 1999).

Researchers have proposed that the associations that are sometimes reported between childhood leukemia and power lines may be due to other factors that can confound the analysis. One example is heavy traffic, which may occur near power lines and can increase the levels of potentially carcinogenic chemicals in the area. Earlier studies had reported associations between traffic density and childhood cancer (Savitz et al., 1988). If power lines were more common in areas that had higher traffic density, then the increased air pollution might explain an association between power lines and childhood cancer. However, more recent studies seem to eliminate this possibility. In a study of 90 cases of childhood leukemia, Reynolds et al. (2001) found no evidence of an association with traffic density. In a larger study that included 986 cases of childhood leukemia, no association was found with high traffic-density exposure during pregnancy or childhood (Raaschou-Nielsen et al., 2001). In addition, no association with childhood leukemia or brain cancer was found for exposures to benzene or nitrogen dioxide. Associations were reported between Hodgkin's disease and exposure to each of these chemicals.

#### *Meta-analyses of studies of leukemia*

Recently, researchers reanalyzed the data from previous epidemiology studies of magnetic fields and childhood leukemia (Ahlbom et al., 2000; Greenland et al., 2000). The researchers pooled the data on individuals from each of the studies, creating a study with a larger number of subjects and therefore greater statistical power than any single study. A pooled analysis is preferable to other types of meta-analyses in which the results from several studies are combined from grouped data obtained from the published studies. These analyses focused on studies that assessed exposure to magnetic fields using 24-hour measurements or calculations based on the characteristics of the power lines and current load. Both Ahlbom et al. and Greenland et al. used exposure categories of <0.1 microtesla ( $\mu\text{T}$ ) (<1 mG) as a reference category. The statistical results of these analyses can be summarized as follows:

- The pooled analyses provided no indication that wire codes are more strongly associated with leukemia than measured fields.
- Pooling these data corroborates an absence of an association between childhood leukemia and magnetic fields for exposures below 0.3  $\mu\text{T}$  (3 mG).
- Pooling these data results in a statistical association with leukemia for exposures greater than 0.3 or 0.4  $\mu\text{T}$  (3-4 mG).

The authors are appropriately cautious in the interpretation of their analyses, and they clearly identify the limitations in their evaluation of the original studies. Magnetic fields above 0.3  $\mu$ T in residences are estimated to be rather rare, about 3% in the U.S. (Zaffanella, 1993). Limitations include sparse data (few cases) to adequately characterize a relationship between magnetic fields and leukemia, uncertainties related to pooling different magnetic-field measures without evidence that all of the measures are comparable, and incomplete and limited data on important confounders (other risk factors for disease that may distort the analysis) such as housing type and traffic density.

A meta-analysis of the data from epidemiologic studies of childhood leukemia studies was presented at the California Workshop and recently published (Wartenberg, 2001b). This meta-analysis did not have the advantage of obtaining and pooling the data on all of the individuals in the studies, unlike those published before it (Ahlbom et al., 2000; Greenland et al., 2000). Rather than individual data, Wartenberg (2001b) used an approach that extracted the published results, reported as grouped data from several published studies. He used 19 studies overall, after excluding 7 studies that had insufficient data on individuals or deficiencies in the exposure assessment data. He reported a weak association for a) “proximity to electrical facilities” based on wire codes or distance, and b) magnetic-field level over 2 mG, based on either calculations from wiring and loading characteristics (if available) or on spot magnetic-field measurements. The results show more cases than controls exposed to measured or calculated fields above 2 mG. The author concludes that the analysis supports an association, although the size of the effect is small to moderate, but also notes “limitations due to design, confounding, and other biases may suggest alternative interpretations” (Wartenberg, 2001b:S-100).

The results of this meta-analysis are not directly comparable to previous ones regarding fields of 3 or 4 mG because the analysis was not based on individual data. The comparison of grouped data used different exposure cut points for the analysis and different criteria for the comparison group. None of these three analyses (Ahlbom et al., 2000; Greenland et al., 2000; Wartenberg, 2001b) includes the results of the UK analysis of over 3000 cases based on calculated fields, which found no association between EMF and childhood cancer, regardless of the exposure level.

### **2.2.2 Epidemiology Studies of Adults**

Studies of adults with certain types of cancer, such as brain cancer, breast cancer, or leukemia, have reported associations with exposure to magnetic fields at residences, but results have not been consistent across studies. Contradictory results among studies argue against a conclusion that the association reflects a cause-and-effect relationship. In their assessments of risk, scientists give most weight to studies that include more people, obtain more detailed and individual exposure assessments, and/or include people who have higher exposures.

A study of 492 adult cases of brain cancer in California included measurements of magnetic fields taken in the home and at the front door, and considered the types of power-line wiring (Wrensch et al., 1999). The authors report no evidence of increased risk with higher exposures, no association with type of power line, and no link with levels measured at the front door.

A number of recent studies of breast cancer focused on electric blankets as a source of high exposure. Electric blankets are assumed to be one of the strongest sources of EMF exposure in the home. Three studies of electric blanket use found no evidence that long-term use increased the risk of breast cancer. Women who developed breast cancer reported no difference in total use of electric blankets, use in recent years, or use many years in the past:

- Gammon et al. (1998) reported that, even for those who kept the blanket on most of the time, no increase in risk was found for those who had longer duration of use (measured in months).

- A study of 608 breast cancer cases also found no evidence of increased use of electric blankets or other home appliances in cases compared to controls, and no indication of increasing risk with a longer time of use (Zheng et al., 2000).
- In a cohort of over 120,000 female nurses, data were obtained on known risk factors for breast cancer as well as electric-blanket use (Laden et al., 2000). For a large subset of this group, the questions about exposure were asked before the disease occurred, a step taken to eliminate bias in recalling exposure.

Erren (2001) reported the results of a meta-analysis of the studies of breast cancer, in which the results of 24 different studies in women were statistically aggregated. When the results of all 24 studies were pooled, including studies of workplace exposures, the estimate indicated an association between EMF and a small excess breast cancer risk. The pooled results for exposure to EMF in the vicinity of electrical facilities did not show an association with breast cancer, nor did the results for exposure to EMF from appliance use. However, the meta-analysis also showed a lack of consistency among the results of the individual studies, a broad variation in the designs, and a wide range of methods used to assess exposure. No adjustments were made to the data to give increased weight to studies based on more comprehensive exposure assessments. The author also noted that the weak statistical association might be an artifact (a result of chance or unforeseen error) rather than an indication of a cause-and-effect relationship (Erren, 2001).

### **2.2.3 Laboratory Studies of EMF**

Laboratory studies complement epidemiologic studies of people because the effects of heredity, diet, and other health-related exposures of animals can be better controlled or eliminated. The assessment of EMF and health, as for any other exposure, includes chronic, long-term studies in animals (*in vivo* studies) and studies of changes in genes or other cellular processes observed in isolated cells and tissues in the laboratory (*in vitro*).

Although the results of the RAPID Program were described in some detail in the NIEHS reports (NIEHS, 1998), many of the studies had not been published in the peer-reviewed literature. The RAPID research program included studies of four biological effects, each of which had been observed in only one laboratory. These effects are as follows: effects on gene expression, increased intracellular calcium in a human cell line, proliferation of cell colonies on agar, and increased activity of the enzyme ornithine decarboxylase (ODC). Some scientists have suggested that these biological responses are signs of possible adverse health effects of EMF. It is standard scientific procedure to attempt to replicate results in other laboratories, because artifacts and investigator error can occur in scientific investigations. Replications, often using more experiments or more rigorous protocols, help to ensure objectivity and validity. Attempts at replication can substantiate and strengthen an observation, or they may discover the underlying reason for the observed response.

Studies in the RAPID program reported no consistent biological effects of EMF exposure on gene expression, intracellular calcium concentration, growth of cell colonies on agar, or ODC activity (Boorman et al., 2000b). For example, Loberg et al. (2000) and Balcer-Kubiczek et al. (2000) studied the expression of hundreds of cancer-related genes in human mammary or leukemia cell lines. They found no increase in gene expression with increased intensity of magnetic fields. To test the experimental procedure, they used X-rays and treatments known to affect the genes. These are known as positive controls and, as expected, caused gene expression in exposed cells.

Scientists have concluded that the combined animal bioassay results provide no evidence that magnetic fields cause, enhance, or promote the development of leukemia and lymphoma, or mammary cancer (e.g., Boorman et al., 1999; McCormick et al., 1999; Boorman et al., 2000 a, b; Anderson et al., 2001).

#### **2.2.4 Summary Regarding Cancer**

Epidemiology studies do not support the idea that EMF from power lines increase the risk of cancers in adults. The latest epidemiologic studies of childhood cancer, considered in the context of the other data, provide no persuasive and consistent evidence that leukemia in children is causally associated with magnetic fields measured at the home, calculated based on distance and current loading, or with wire codes. Recent meta-analyses reported no association between childhood cancer and magnetic fields below 2 or 3 mG. Although some association was reported for fields above this level, fields at most residences are likely to be below 3 or 4 mG. The authors of each of these analyses list several biases and problems that render the data inconclusive, and prevent resolution of the inconsistencies in the epidemiologic data. For this reason, laboratory studies can provide important complementary information. Large, well-conducted animal studies provide no convincing evidence that exposure increases the risk of cancer. Animal studies, and studies of initiation and promotion, provide no basis to conclude that EMF increases leukemia, lymphoma, breast, brain, or any other type of cancer.

### **2.3 Research Related to Reproduction**

Previous epidemiologic studies reported no association with birth weight or fetal growth retardation after exposure to sources of relatively strong magnetic fields, such as electric blankets, or sources of typically weaker magnetic fields such as power lines (Bracken et al., 1995; Belanger et al., 1998).

A recent epidemiology study examined miscarriages<sup>2</sup> in relation to exposures to magnetic fields from electric bed-heating (electric blankets, heated waterbeds and mattress pads), which result in higher exposures than residential fields in general (Lee et al., 2000). The researchers assessed exposure prior to the birth (a prospective study) and included information to control for potential confounding factors (other exposures and conditions that affect the risk of miscarriage). This study had a large number of cases and high participation rates. Miscarriage rates were lower among users of electric bed heating.

Studies of laboratory animals exposed to pure 60-Hz fields have shown no increase in birth defects, no multigenerational effects, and no changes that would indicate an increase in miscarriage or loss of fertility (e.g., Ryan et al., 1999; Ryan et al., 2000). Exposed and unexposed litters were no different in the amount of fetal loss and the number and type of birth defects, indicating no reproductive effect of EMF.

In summary, the recent evidence from epidemiology and laboratory studies provides no indication that exposure to power-frequency EMF has an adverse effect on reproduction, pregnancy, or growth and development of the embryo. The results of these recent studies are consistent with the conclusions of the NIEHS.

### **2.4 Other Recent Reviews by Scientific Advisory Groups**

Reviews of the scientific research regarding EMF and health by Health Council of the Netherlands and the Institute of Electrical Engineers of the UK were published in 2000. The National Radiological

---

<sup>2</sup> The medical term for miscarriage is spontaneous abortion.



Protection Board of Great Britain (NRPB) Advisory Group on Non-Ionizing Radiation published the most recent review in 2001. This review includes research published in 2000, and includes the most comprehensive discussion of the individual research studies.

#### **2.4.1 National Radiological Protection Board of Great Britain (NRPB) Advisory Group on Non-Ionising Radiation**

The conclusions from the report prepared by the NRPB's Advisory Group on Non-Ionising Radiation (AGNIR) on extremely low frequency (ELF) EMF and the risk of cancer are consistent with previous reviews. Members from universities, medical schools, and cancer research institutes reviewed the reports of experimental and epidemiological studies, including reports in the literature in 2000. Their general conclusions are as follows:

Laboratory experiments have provided no good evidence that extremely low frequency electromagnetic fields are capable of producing cancer, nor do human epidemiological studies suggest that they cause cancer in general. There is, however, some epidemiological evidence that prolonged exposure to higher levels of power frequency magnetic fields is associated with a small risk of leukaemia in children. In practice, such levels of exposure are seldom encountered by the general public in the UK [or in the US] (NRPB, 2001: 164).

The group further recognizes that the scientific evidence suggesting that exposure to power-frequency electromagnetic fields poses an increased risk of cancer is very weak. Virtually all of the cellular, animal, and human laboratory evidence provides no support for an increased risk of cancer incidence following such exposure to power frequencies, although sporadic positive findings have been reported. In addition, the epidemiological evidence is, at best, weak.

These conclusions of the Advisory Group are consistent with previous reviews by the NIEHS (1999) and the Health Council of the Netherlands (HCN, 2000). The NRPB response to the Advisory Group report states "the review of experimental studies by [the Advisory Group] AGNIR gives no clear support for a causal relationship between exposure to ELF-EMFs and cancer" (NRPB, 2001:1).

#### **2.4.2 Health Council of the Netherlands**

The Health Council of the Netherlands has prepared an update of its 1992 Advisory Report on exposure to electromagnetic fields (0 Hz to 10 MHz) (HCN, 2000). Members of the Expert Committee prepared the report. The Expert Committee based its analysis on the review and summaries of the studies provided in the NIEHS (1998) and concurred with the views of the director of the NIEHS (1999). For the update, the Committee evaluated a number of publications that appeared after these reports, e.g., McBride et al. (1999) and Green et al. (1999a), and wrote:

The committee thinks that the quality of the relevant epidemiological research has improved considerably since the publication of the advisory report in 1992. Even so, this research has not resulted in unequivocal, scientifically reliable conclusions (p. 15).

The Council emphasizes that the associations with EMF reported in epidemiologic studies are strictly statistical and do not demonstrate a cause-and-effect relationship. In their view, experimental research does not demonstrate a causal link or a mechanism to explain EMF as a cause of disease in humans. They concluded that there is no reason to recommend measures to limit residence near overhead power lines (HCN, 2000).

### **2.4.3 Institution of Electrical Engineers (IEE) of Great Britain**

One of the recent reviews was that of the Institution of Electrical Engineers (IEE) of Great Britain (IEE, 2000). In 1992, the IEE set up a Working Party whose eight members, with broad expertise in the health sciences, review the relevant scientific literature and prepare reports of their views. Their conclusion is based on recent major epidemiologic studies and the scientific literature built up over the past 20 years. In May 2000, the Working Party concluded “. . . that there is still not convincing scientific evidence showing harmful effects of low level electromagnetic fields on humans” (IEE, 2000:1).

## **3.0 Ecological Research**

Scientists have studied the effects of high-voltage transmission lines on many plant and animal species in the natural environment. In this section, we briefly review the research on the effects of EMF on ecological systems to assess the likelihood of adverse impacts. In addition to the comprehensive review of research on this topic by wildlife biologists at the BPA (Lee et al., 1996), we searched the published scientific literature for more recent studies published between 1995 and May 2001.

### **3.1 Fauna**

The habitat on the transmission-line right-of-way and surrounding area shields most wildlife from electric fields. Vegetation in the form of grasses, shrubs, and small trees largely shields small ground-dwelling species such as mice, rabbits, foxes, and snakes from electric fields. Species that live underground, such as moles, woodchucks, and worms, are further shielded from electric fields by the soil. Hence, large species such as deer and domestic livestock (e.g., sheep and cattle) have greater potential exposures to electric fields since they can stand taller than surrounding vegetation. However, the duration of exposure for deer and other large animals is likely to be limited to foraging bouts or the time it takes them to cross under the line. Furthermore, all species would be exposed to higher magnetic fields under a transmission-line than elsewhere, as the vegetation and soil do not provide shielding from this aspect of the transmission-line electrical environment.

Field studies have been performed in which the behavior of large mammals in the vicinity of high-voltage transmission lines was monitored. No effects of electric or magnetic fields were evident in two studies from the northern United States on big game species, such as deer and elk, exposed to a 500-kV transmission line (Goodwin 1975; Picton et al., 1985). In such studies, a possible confounding factor is audible noise. Audible noise associated with high-voltage power transmission lines (with voltages greater than 110-kV) is due to corona. Audible noise generated by transmission lines reaches its highest levels in inclement weather (rain or snow).

Much larger populations of animals that might spend time near a transmission line are livestock that graze under or near transmission lines. To provide a more sensitive and reliable test for adverse effects than informal observation, scientists have studied animals continuously exposed to fields from the lines in relatively controlled conditions. For example, grazing animals such as cows and sheep have been exposed to high-voltage transmission lines and their reproductive performance examined (Lee et al., 1996). In some studies, the effects of exposure over one or more successive breedings were examined (Angell et al., 1990). Compared to unexposed animals in a similar environment, it was found that the exposure did not affect reproductive functions or pregnancy of cows (Algers and Hennichs, 1985; Algers and Hultgren, 1987).

A group of investigators from Oregon State University, Portland State University, and other academic centers evaluated the effects of long-term exposure to EMF from a 500-kV transmission line operated by

BPA on various cellular aspects of immune response, including the production of proteins by leukocytes (IL-1 and IL-2) of sheep. In previous unpublished reports, the researchers found differences in IL-1 activity between exposed and control groups. However, in their most recent replication, the authors found no evidence of differences in these measures of immune function. The sheep were exposed to 27 months of continuous exposure to EMF, a period of exposure much greater than the short, intermittent exposures of sheep grazing under transmission lines. Mean exposures of magnetic and electric fields were 3.5-3.8  $\mu$ T (35-38 mG) and 5.2-5.8 kV/m, respectively (Hefeneider et al., 2001).

Scientists from Illinois Institute of Technology (IIT) monitored the possible effects of electric and magnetic fields on fauna and flora in Michigan and Wisconsin from 1969 – 1997 to evaluate the effects of an above-ground, military-communications antenna operating at 76 Hz. The antenna produces EMF similar in physical characteristics to those produced by high-voltage transmission lines, but of much lower intensity. This study included embryonic development, fertility, postnatal growth, maturation, aerobic metabolism, and homing behavior, and showed no adverse impacts of ELF electric and magnetic fields on the animals (NRC, 1997).

The hormone melatonin, secreted at night by the pineal gland, plays a role in animals that are seasonal breeders. Studies in laboratory mice and rats have suggested that exposure to electric and/or magnetic fields might affect levels of the hormone melatonin, but results have not been consistent (Wilson et al., 1981; Holmberg, 1995; Kroeker et al., 1996; Vollrath et al., 1997; Huuskonen et al., 2001). However, when researchers examined sheep and cattle exposed to EMF from transmission lines exceeding 500-kV, they found no effect on the levels of the hormone melatonin in blood, weight gain, onset of puberty, or behavior in sheep and cattle (Stormshak et al., 1992; Lee et al., 1993; Lee et al., 1995; Thompson et al., 1995; Burchard et al., 1998).

Another part of the IIT study examined the effect of the antenna system fields on the growth, development, and homing behavior of birds. Studies of embryonic development (Beaver et al., 1993), fertility, postnatal growth, maturation, aerobic metabolism, and homing behavior showed no adverse impacts of ELF electric and magnetic fields on the animals (NRC, 1997). Fernie and colleagues studied the effects of continuous EMF exposure of raptors to an electric field of 10 kV/m in a controlled, laboratory setting. The exposure was designed to mimic exposure to a 765-kV transmission line. Continuous EMF exposure was found to reduce hatching success, yet increase egg size, fledging success, and embryonic development (Fernie et al., 2000). In a study of the effects on body mass and food intake of reproducing falcons, the authors found that EMF lengthened the photoperiod as a result of altered melatonin levels in the male species, yet concluded that “EMF effects on adult birds may only occur after continuous, extended exposure,” which is not likely to occur from resting on power lines (Fernie and Bird, 1999:620).

Several avian species are reported to use the earth’s magnetic field as one of the cues for navigation. It has been proposed that deposits of magnetite in specialized cells in the head are the mechanism by which the birds can detect variations in the inclination and intensity of a dc magnetic field (Kirschvink and Gould, 1981; Walcott et al., 1988). In early studies of transmission lines, it was reported that the migratory patterns of birds appeared to be altered near transmission lines (Southern, 1975; Larkin and Sutherland, 1977). However, these studies were of crude design, and Lee et al. (1996) concluded that, “During migration, birds must routinely fly over probably hundreds (or thousands) of electrical transmission and distribution lines. We are not aware of any evidence to suggest that such lines are disrupting migratory flights” (p. 4-59). No further studies on this topic were identified in the literature.

Bees, like birds, are able to detect the earth’s dc magnetic fields. They are known to use magnetite particles, which are contained in an abdominal organ, as a compass (Kirschvink and Gould, 1981). In the

laboratory, they are able to discriminate between a localized magnetic anomaly and a uniform background dc magnetic field (Walker et al., 1982; Kirschvink et al., 1992).

Greenberg et al. (1981) studied honeybee colonies placed near 765-kV transmission lines. They found that hives exposed to electric fields of 7 kV/m had decreased hive weight, abnormal amounts of propolis (a resinous material) at hive entrances, increased mortality and irritability, loss of the queen in some hives, and a decrease in the hive's overall survival compared to hives that were not exposed. Exposure to electric fields of 7-12 kV/m may induce a current or heat the interior of the hive; however, placing the hive farther from the line, shielding the hive, or using hives without metallic parts eliminates this problem. ITT studied the effects of EMF on bees exposed to the 76-Hz antenna system at lower intensities and concluded that these behavioral effects of "ELF-EMF impacts are absent or at most minimal" (NRC, 1997:102).

Reptiles and amphibians contribute to the overall functioning of the forest ecosystems. However, little research has been performed on the effects of EMF on reptiles and amphibians in their natural habitat.

### **3.2 Flora**

Numerous studies have been carried out to assess the effect of exposure of plants to transmission-line electric and magnetic fields. These studies have involved both forest species and agriculture crops. Researchers have found no adverse effects on plant responses, including seed germination, seedling emergence, seedling growth, leaf area per plant, flowering, seed production, germination of the seeds, longevity, and biomass production (Lee et al., 1996).

The only confirmed adverse effect of transmission lines on plants was reported for transmission lines with voltages above 1200-kV. For example, Douglas Fir trees planted within 15 m of the conductors were shorter than trees planted away from the line. Shorter trees are believed to result from corona-induced damage to the branch tips. Trees between 15 and 30 m away from the line suffered needle burns, but those 30 m and beyond were not affected (Rogers et al., 1984). These effects would not occur at the lower field intensities expected beyond the right-of-way of the proposed 500-kV transmission line.

### **3.3 Summary**

The habitat on the transmission-line rights-of-way and surrounding areas shield smaller animals from electric fields produced by high-voltage transmission lines; thus, vegetation easily shields small animals from electric fields. The greatest potential for larger animals to be exposed to EMF occurs when they are passing beneath the lines. Studies of animal reproductive performance, behavior, melatonin production, immune function, and navigation have found minimal or no effects of EMF. Past studies have found little effect of EMF on plants; no recent studies of plants growing near transmission lines have been performed. In summary, the literature published to date has shown little evidence of adverse effects of EMF from high-voltage transmission lines on wildlife and plants. At the field intensities associated with the proposed 230-kV transmission line, no adverse effects on wildlife or plants are expected.

## **LIST OF REFERENCES**

- Ahlbom, A.; Day, N.; Feychting, M.; Roman, E.; Skinner, J.; Dockerty, J.; Linet, M.; Michealis, J.; Olsen, J.H.; Tynes, T.; Verasalo, P.K. 2000. A pooled analysis of magnetic fields and childhood leukaemia. *British Journal of Cancer*, 83(5): 692-698.
- Algers, B.; and Hennichs, K. 1985. The effect of exposure to 400-kV transmission lines on the fertility of cows: a retrospective cohort study. *Preventive Veterinary Medicine* 3: 351-361.
- Algers, B.; and Hultgren, J. 1987. Effects of long-term exposure to a 400-kV, 50-Hz transmission line on estrous and fertility in cows. *Preventive Veterinary Medicine* 5: 21-36.
- Anderson, L.E.; Morris, J.E.; Miller, D.L.; Rafferty, C.N.; Ebi, K.L.; Sasser, L.B. 2001. Large granular lymphocytic (LGL) leukemia in rats exposed to intermittent 60 Hz magnetic fields. *Bioelectromagnetics*, 22:185-193.
- Angell, R.F.; Schott, M.R.; Raleigh, R.J.; Bracken, T.D. 1990. Effects of a high-voltage direct-current transmission line on beef cattle production. *Bioelectromagnetics*. 11(4):273-82.
- Balcer-Kubiczek, E.K.; Harrison, G.H.; Davis, C.C.; Haas, M.L.; Koffman, B.H. 2000. Expression analysis of human HL60 exposed to 60 Hz square or sine-wave magnetic fields. *Radiation Research*, 153(5): 670-678.
- Beaver, D.L.; Hill, R.W.; Lederle, P.E. 1993. Assessment of the effects of extremely low frequency electromagnetic radiation on growth and maturation in nestling tree swallows and deer mice. *Electricity and Magnetism in Biology and Medicine*. M. Blank, ed., San Francisco Press, Inc., pp. 925-926.
- Belanger, K.; Leaderer, B.; Hellenbrand, K.; Holford, T.R.; McSharry, J.; Power, M.E.; Bracken, M.B. 1998. Spontaneous abortion and exposure to electric blankets and heated water beds. *Epidemiology*, 9:36-42.
- Boorman, G.A.; Anderson, L.E.; Morris, J.E.; Sasser, L.B.; Mann, P.C.; Grumbein, S.L.; Hailey, J.R.; McNally, A.; Sills, R.C.; Haseman, J.K. 1999. Effects of 26-week magnetic field exposure in a DMBA initiation-promotion mammary glands model in Sprague-Dawley rats. *Carcinogenesis*, 20: 899-904.
- Boorman, G.A.; McCormick, D.J.; Ward, J.M.; Haseman, J.K.; Sills, R.C. 2000a. Magnetic fields and mammary cancer in rodents: A critical review and evaluation of published literature. *Radiation Research*, 153(5), Part 2: 617.
- Boorman, G.A.; Rafferty, C.N.; Ward, J.M.; Sills, R.C. 2000b. Leukemia and lymphoma incidence in rodents exposed to low-frequency magnetic fields. *Radiation Research*, 153(5), Part 2: 627.
- Bracken, M.B.; Belanger, K.; Hellenbrand, K.; Dlugosz, L.; Holford, T.R.; McSharry, J.E.; Adesso, K.; Leaderer, B. 1995. Exposure to electromagnetic fields during pregnancy with emphasis on electrically heated beds: association with birth weight and intrauterine growth retardation. *Epidemiology*, 6(3): 263-270.

- Burchard, J.F.; Nguyen, D.H.; Block, E. 1998. Effects of electric and magnetic fields on nocturnal melatonin concentrations in dairy cows. *J Dairy Sci.* 81(3):722-7.
- Erren, T.C. 2001. A meta-analysis of epidemiological studies of electric magnetic fields and breast cancer in women and men. *Bioelectromagnetics Supplement*, 5: S105-S119.
- Fernie, K.J.; and Bird, D.M. 1999. Effects of electromagnetic fields on body mass and food-intake of American kestrels. *The Condor.* 101:616-621.
- Fernie, K.J.; Bird, D.M.; Dawson, R.D.; Lague, P.C. 2000. Effects of electromagnetic fields on the reproductive success of American kestrels. *Physiol Biochem Zool.* 73(1):60-5.
- Gammon, M.D.; Schoenberg, J.B.; Britton, J.A.; Kelsey, J.L.; Stanford, J.L.; Malone, K.E.; Coates, R.J.; Brogan, D.J.; Potischman, N.; Swanson, C.A.; Brinton, L.A. 1998. Electric blanket use and breast cancer risk among younger women. *American Journal of Epidemiology*, 148: 556-63.
- Goodwin Jr., J.G. 1975. Big game movement near a 500-kV transmission line in northern Idaho. Bonneville Power Administration, Engineering and Construction Division, Portland, OR, June 27.
- Green, L.M.; Miller, A.B.; Villeneuve, P.J.; Agnew, D.A.; Greenberg, M.L.; Li, J.H.; Donnelly, K.E. 1999a. A case control study of childhood leukemia in southern Ontario, Canada, and exposure to magnetic fields in residences. *International Journal of Cancer*, 82:161-170.
- Green, L.M.; Miller, A.B.; Agnew, D.A.; Greenberg, M.L.; Li, J.H.; Villeneuve, P.J.; Tibshirani, R. 1999b. Childhood leukemia and personal monitoring of residential exposures to electric and magnetic fields in Ontario, Canada. *Cancer Causes and Control*, 10: 233-243.
- Greenberg, B.; Bindokas, V.P.; Frazier, M.J.; Gauger, J.R. 1981. Response of honey bees, *apis mellifera* L., to high-voltage transmission lines. *Environmental Entomology*, 10: 600-610.
- Greenland, S.; Sheppard, A.; Kelsh, M.; Kuane, W.; Poole, C.; Kelsh, M.A. 2000. Childhood leukemia and power frequency magnetic fields: analysis from pooled data of thirteen epidemiologic studies. *Epidemiology*, 11: 624-634.
- HCN (Health Council of the Netherlands). 2000. Report on Exposure to Electromagnetic Fields (0 Hz – 10 MHz). No. 2000/06E.
- Hefeneider, S.H.; McCoy, S.L.; Hausman, F.A.; Christensen, H.L.; Takahashi, D.; Perrin, N.; Bracken, T.D.; Shin, K.Y.; Hall, A.S. 2001. Long-term effects of 60-Hz electric vs. magnetic fields on IL-1 and IL-2 activity in sheep. *Bioelectromagnetics*, 22(3):170-177.
- Holmberg, B. 1995. Magnetic fields and cancer: animal and cellular evidence—an overview. *Environ Health Perspect.* 103 Suppl 2:63-7.
- Huuskonen, H.; Saastamoinen, V.; Komulainen, H.; Laitinen, J.; Juutilainen, J. 2001. Effects of low-frequency magnetic fields on implantation in rats. *Reprod Toxicol*, 15(1):49-59.
- IEE (Institution of Electrical Engineers), Biological Effects Working Party. May 2000. The possible harmful biological effects of low level electromagnetic fields of frequencies up to 300 GHz. IEE Position Statement.

- Kirschvink, J.L.; and Gould, J.L. 1981. Biogenic magnetite as a basis for magnetic field detection in animals. *Biosystems*, 13(3):181-201.
- Kirschvink, J.L.; Diaz Ricci, J.; Nesson, M.H.; Kirschvink, S.J. 1992. Magnetite-based magnetoreceptors in animals: structural, behavioral, and biophysical studies. Electric Power Research Institute (EPRI), Report No. TR-102008, Palo Alto, CA. September.
- Kroeker, G.; Parkinson, D.; Vriend, J.; Peeling, J. 1996. Neurochemical effects of static magnetic field exposure. *Surg Neurol*, 45(1):62-6.
- Laden, F.; Neas, L.M.; Tolbert, P.E.; Holmes, M.D.; Hankinson, S.E.; Spiegelman, D.; Speizer, F.E.; Hunter, D.J. 2000. Electric blanket use and breast cancer in the nurses' health study. *American Journal of Epidemiology*, 152(1): 41-49.
- Langholz, B. 2001. Factors that explain the power line configuration wiring code - childhood leukemia association: what would they look like? *Bioelectromagnetics Supplements*, 5: S19-S31.
- Larkin, R.P., and Sutherland, P.J. 1977. Migrating birds respond to Project Seafarer's electromagnetic field. *Science*, 195(4280): 777-9 1977, Feb 25.
- Lee, G.M.; Neutra, R.R.; Hristova, L.; Yost, M.; Hiatt, R.A. 2000. The use of electric bed heaters and the risk of clinically recognized spontaneous abortion. *Epidemiology*, 11: 406-415.
- Lee, J., Stormshak, F., Thompson, J., Thinesen, P., Painter, L., Olenchek, B., Hess, D., Forbes, R. 1993. Melatonin secretion and puberty in female lambs exposed to environmental electric and magnetic fields. *Biol Reprod* 49(4):857-64
- Lee, J.M. BPA Biological Studies Task Team. 1996. Electrical and biological effects of transmission lines: a review. Bonneville Power Administration, Portland, Oregon, December.
- Lee, J.M., Stormshak, F., Thompson, J., Hess, D.L., Foster, D.L. 1995. Melatonin and puberty in female lambs exposed to EMF: a replicate study. *Bioelectromagnetics*, 16(2):119-23
- Linnet, M.S.; Hatch E.H.; Kleinerman, R.A.; Robinson, L.L.; Kaune, W.T.; Friedman, D.R.; Seversch, R.K.; Haines, C.M.; Hartsock, C.T.; Niwa, S.; Wacholder, S.; Tarone, R.E. 1997. Residential exposure to magnetic fields and acute lymphoblastic leukemia in children. *New England Journal of Medicine*, 337: 1-7.
- Loberg, L.I.; Engdahl, W.R.; Gauger, J.R.; McCormick, D.L. 2000. Expression of cancer-related genes in human cells exposed to 60 Hz magnetic fields. *Radiation Research*, 153(5): 679-684.
- McBride, M.L.; and Gallagher, RP; Theriault, G; Armstrong, BG; Tamaro, S; Spinelli, JJ; Deadman, JE; Fincham, S; Robinson, D; Choi, W. 1999. Power-frequency electric and magnetic fields and risk of childhood leukemia in Canada. *American Journal of Epidemiology*, 149:831-842.
- McCormick, D.L.; Boorman, G.A.; Findlay, J.C.; Hailey, J.R.; Johnson, T.R.; Gauger, J.R.; Pletcher, J.M.; Sill, R.C.; Haseman, J.K. 1999. Chronic toxicity/oncogenicity evaluation of 60 Hz (power frequency) magnetic fields in B6C3F mice. *Toxicologic Pathology*, 27:279-285.

- Neutra, R.R., and Del Pizzo, V. 2001. A richer conceptualization of "exposure" for epidemiological studies of the "EMF mixture". *Bioelectromagnetics Supplements*, 5: S48-S57.
- NIEHS (National Institute of Environmental Health Sciences). 1998. Assessment of Health Effects from Exposure to Power-Line Frequency Electric and Magnetic Fields: Working Group Report. NIH Publication No. 98-3981. Research Triangle Park, NC: National Institute of Environmental Health Sciences of the U.S. National Institutes of Health.
- NIEHS (National Institute of Environmental Health). 1999. Health effects from exposure to power line frequency electric and magnetic fields. NIH; National Institute of Health; NIH No. 99-4493; Research Triangle Park, NC.
- NRC (National Research Council). 1997. An evaluation of the U.S. Navy's extremely low frequency communications system ecological monitoring program. National Academy Press, Washington, D.C.
- NRPB (National Radiological Protection Board). 2001. Response statement of the NRPB: ELF electromagnetic fields and the risk of cancer. National Radiological Protection Board, Chilton, Didcot, Oxon, Volume 12, No.1, ISBN 0-859951-456-0.
- Picton, H.D., Canfield, J.E., Nelson, G.P. 1985. The impact of a 500-kV transmission line upon the North Boulder Winter Elk Range. US Forest Service Contract 53-0398-30E-3.
- Raaschou-Nielsen, O.; Hertel, O.; Thomsen, B.L.; Olsen, J.H. 2001. Air pollution from traffic at the residence of children with cancer. *American Journal of Epidemiology*, 153(5): 433-43.
- Radiation Research*. 2000. (Special Edition Updating RAPID results.) 153(5): 637-641. *See entries under Balcer-Kubiczek, Boorman, Loberg, and Ryan.*
- Reynolds, P.; Elkin, E.; Scalf, R.; Von Behren, J.; Neutra, R.R. 2001. A case-control pilot study of traffic exposures and early childhood leukemia using a geographic information system. *Bioelectromagnetics Supplements*, 5:S58-S6.
- Rogers, L.E., Beedlow, P.A., Carlile, D.W., Ganok, K.A., Lee, J.M. 1984. Environmental studies of a 1100-kV prototype transmission line: an annual report for the 1984 study period. Prepared by Battelle Pacific Northwest Laboratories for Bonneville Power Administration, Portland, Oregon.
- Ryan, B.M.; Symanski, R.R.; Pomeranz, L.E.; Johnson, T.R.; Gauger, J.R.; McCormick, D.L. 1999. Multi-generation reproduction toxicity assessment of 60-Hz magnetic fields using a continuous breeding protocol in rats. *Teratology*, 59(3): 156-62.
- Ryan, B.M.; Polen, M.; Gauger, J.R.; Mallett, E.; Kerns, M.B.; Bryan, T.L.; McCormick, D.L. 2000. Evaluation of the developmental toxicity in Sprague-Dawley rats. *Radiation Research*, 153(5): 637-641.
- Savitz, D.A., Wachtel, H., Barnes, F.A., John, E.M. & Tvrdik, J.G. 1988. Case-control study of childhood cancer and exposure to 60 Hz magnetic fields. *American Journal of Epidemiology*, 128, 21-38.
- Schuz, J.; Grigat, J.P.; Brinkmann, K.; Michaelis, J. 2001. Residential magnetic fields as a risk factor for childhood acute leukaemia: results from a German population-based case-control study. *International Journal of Cancer*, 91(5): 728-735. January 2.



- Southern, W.E. 1975. Orientation of gull chicks exposed to project Sanguine's electromagnetic field. *Science*, 189: 143-144.
- Stormshak, F., Bracken, T.D., Carey, M., Chartier, V., Dickson, L., Forbes, R., Hall, A., Havens, P., Hess, D., Krippaehne, S., Lee, J., Ogden, B., Olenchek, B., Painter, L., Rowe, K., Stearns, R., Thinesen, P., Thompson, J. 1992. Joint HVAC transmission EMF environmental study: final report on experiment 1. Bonneville Power Administration, Contract # DE-B179-90BPO4293, Portland, OR, May.
- Thompson, J.M.; Stormshak, F.; Lee, J.M.; Hess, D.; Painter, L. 1995. Cortisol secretion and growth in ewe lambs chronically exposed to electric and magnetic fields of a 60-Hertz 500-kilovolt AC transmission line. *J Animal Sci*, 73(11):3274-80
- UKCCS (United Kingdom Childhood Cancer Study Investigators). 1999. Exposure to power frequency magnetic fields and the risk of childhood cancer. *The Lancet*, 353(9194): 1925-31.
- UKCCS (United Kingdom Childhood Cancer Study Investigators). 2000. Childhood cancer and residential proximity to power lines. *British Journal of Cancer*, 83:1573-80.
- Vollrath, L.; Spessert, R.; Kratzsch, T.; Keiner, M.; Hollmann H. 1997. No short-term effects of high-frequency electromagnetic fields on the mammalian pineal gland. *Bioelectromagnetics*, 18(5):376-87.
- Walcott, C.; Gould, J.L.; Lednor, A.J. 1988. Homing of magnetized and demagnetized pigeons. *J Exp Biol*, 134:27-41.
- Walker, C.E.; Seitelman, D.L.; McElhaney, J.H.; Mullen, S.P.; Hagadorn, B.; Seto, Y.J. 1982. Effects of high-intensity 60-Hz fields on bone growth. *Journal of Bioelectricity*, 1(3):339-349.
- Wartenberg, D. 2001a. The potential impact of bias in studies of residential exposure to magnetic fields and childhood leukemia. *Bioelectromagnetics Supplements*, 5: S32-S47.
- Wartenberg, D. 2001b. Residential EMF exposure and childhood leukemia: Meta-analysis and population attributable risk. *Bioelectromagnetics Supplements*, 5: S86-S104.
- Wilson, B.W.; Anderson, L.E.; Hilton, D.I.; Phillips, RD. 1981. Chronic exposure to 60-Hz electric fields: effects on pineal function in the rat. *Bioelectromagnetics*, 2(4):371-80.
- Wrensch, M.; Yost, M.; Miike, R.; Lee, G.; Touchstone, J. 1999. Adult glioma in relation to residential power frequency electromagnetic field exposures in the San Francisco Bay Area. *Epidemiology*, 10: 523-527.
- Zaffanella, L.E. 1993. Survey of residential magnetic field sources. Vol. 1: Goals, results, and conclusions. (EPRI TR-102759-V1, Project 3335-02). Electric Power Research Institute, Palo Alto, CA.
- Zheng, T.Z.; Holford, T.R.; Mayne, S.T.; Owens, P.H.; Zhang, B.; Boyle, P.; Carter, D.; Ward, Y.W.; Zahm, S.H. 2000. Exposure to electromagnetic fields from use of electric blankets and other in-home electrical appliances and breast cancer risk. *American Journal of Epidemiology*, 151(11): 1103-11.

## LIST OF PREPARERS

**Linda S. Erdreich, Ph.D.**, is a Managing Scientist in the Health Group at Exponent. She received her Ph.D. in Epidemiology and an M.S. in Biostatistics and Epidemiology from The University of Oklahoma Health Sciences Center. Dr. Erdreich is an epidemiologist with specific expertise in biological and health research related to non-ionizing radiation, both radiofrequency and power-frequency fields. Formerly, she was Acting Section Chief and Group Leader of the Methods Evaluation and Development Staff at the U.S. Environmental Protection Agency (EPA) and Senior Epidemiologist of the Environmental Criteria and Assessment Office at the EPA. While at the EPA, she developed methods in quantitative health risk assessment, coordinated the drafting of federal guidelines, and participated in science policy decisions. Both in government and private industry, she has provided rigorous evaluations of the impact on public health or occupational health of a variety of chemicals, therapeutic drugs, and physical agents, including electric and magnetic fields. As a member of the Institute of Electrical and Electronics Engineers (IEEE) Standards Coordinating Committees on Non-Ionizing Radiation, Dr. Erdreich is chairman of a working group to evaluate epidemiologic data on radiofrequency exposures (3 kHz–300 GHz). She has been appointed as a member of the Committee on Man and Radiation (COMAR) of the IEEE's *Engineering in Biology and Medicine Society*. Dr. Erdreich serves as Adjunct Associate Professor at the University of Medicine & Dentistry of New Jersey.

**William H. Bailey, Ph.D.**, is a Principal Scientist and manages the Health Group scientists in Exponent's New York office. Before joining Exponent, Dr. Bailey was President of Bailey Research Associates, Inc., the oldest research and consulting firm with specialized expertise in electro-magnetic fields and health. Dr. Bailey specializes in applying state-of-the-art assessment methods to environmental health and impact issues. His 30 years of training and experience include laboratory and epidemiologic research, health risk assessment, and comprehensive exposure analysis. Dr. Bailey is particularly well known for his research on potential health effects of electromagnetic fields and is active in setting IEEE standards for human exposure to electromagnetic fields. He uses advanced analytical and statistical methods in the design and analysis of both experimental studies and epidemiology and survey research studies. In addition, Dr. Bailey's postgraduate training in the social, economic, and behavioral sciences is helpful in assessing the important effects of social, economic, and community factors on health risks and vulnerability to environmental impacts in health and environmental justice research. He is a member of a working group that advises a committee of the World Health Organization on risk assessment, perception, and communication. Dr. Bailey is also a visiting scientist at the Cornell University Medical College. He was formerly Head of the Laboratory of Neuropharmacology and Environmental Toxicology at the New York State Institute for Basic Research, Staten Island, New York, and an Assistant Professor and NIH postdoctoral fellow in Neurochemistry at The Rockefeller University in New York.

**Maria DeJoseph, M.S.**, is an Epidemiologist in Exponent's Health Group and is based in New York, New York. Ms. DeJoseph has a background in epidemiology and biological sciences. She served as the primary investigator for a case-control epidemiologic study of her design to investigate a mediastinitis outbreak in cardiothoracic surgery patients. Ms. De Joseph also has recruited and interviewed subjects, and analyzed hormone levels for an epidemiologic breast cancer study. She has conducted phytochemical analyses of medicinal plants, including the isolation and fractionation of tropical plants used medicinally by indigenous peoples and primates of Central and South America. Ms. DeJoseph has served as an ethnobotanical and zoopharmacological field researcher in Mexico, Costa Rica and Venezuela. She has used a variety of methods to identify chemical and prospective pharmaceutical compounds, including HPLC, column chromatography, anti-microbial assays, gas chromatography mass spectrometry (GC-MS), and nuclear magnetic resonance spectroscopy (NMR). Before joining exponent, Ms. DeJoseph was a Research Assistant in the Medical School, Division of Epidemiology at Stanford University.

*This page intentionally left blank.*