

2013 DOE Bioenergy Technologies Office (BETO) Project Peer Review

Liquefaction of Forest Biomass to “Drop-in” Hydrocarbon Biofuels

May 23, 2013

Bio-Oil Technology Area Review

Robert C. Brown
Iowa State University

Goal/Objective Statement

- Project Goal: Demonstrate solvent liquefaction as a viable pathway to stable intermediates that can be upgraded to fuel blendstocks
- Funding Opportunity Announcement DE-FOA-00005100
 - R&D, demonstration, and life-cycle evaluation and optimization of technologies for production of biofuels and biobased products
- Supports the goal of producing cost effective intermediate via liquefaction of biomass that can be upgraded to hydrocarbon transportation fuels

Project Quad Chart Overview

Timeline

- Project start date: Jan. 1, 2013
- Contract executed: March, 2013
- Project end date: Dec. 31, 2015
- Percent complete: 13%

Budget

- Total project funding: 4.375 M
- Funding received in FY 2013: 1.6 M
- Funding in FY 2014: 1.525 M
- Funding for FY 2015: 1.02 M
- Funding for FY 2016: 0.23 M
- No ARRA Funding
- Three year project, 1.458 M per year

Barrier

- Tt-E: Pyrolysis of Biomass and Bio-oil Stabilization

Partners & Roles

- Catchlight Energy will move their solvent liquefaction unit to ISU, provide technical direction for design improvements and operation of the unit, and conduct bio-oil upgrading tests

Project Overview

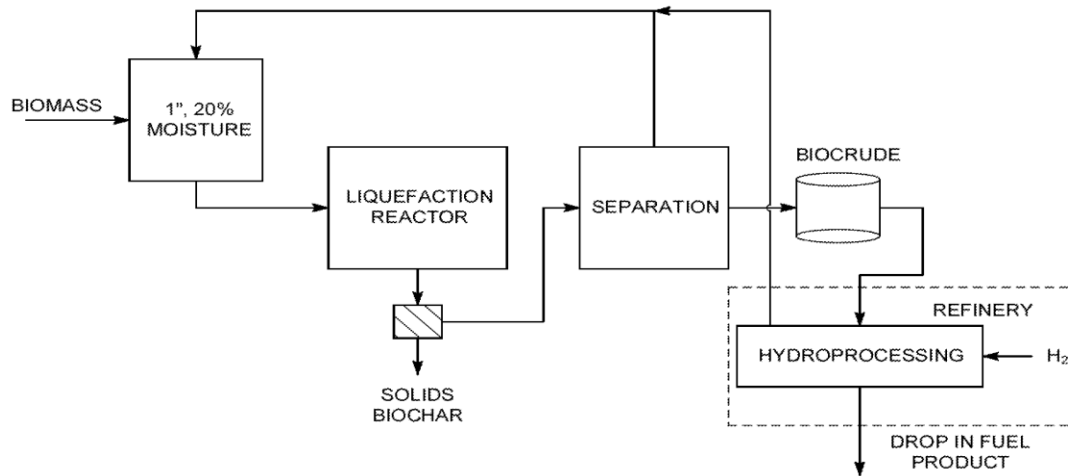

- Key unit operations targeted for improvement
 - Separation of product liquid from solvent
 - Continuous recycling of solvent to reactor
 - Continuous solids (char) removal from liquid stream
 - Hydroprocessing conditions for upgrading bio-oil
- Technical Barrier Addressed: Tt-E: Pyrolysis of Biomass and Bio-oil Stabilization

1 - Approach

- Proof of concept testing using small pilot solvent liquefaction unit with feed rate of 1 kg biomass/hr
- Continuous solvent liquefaction product separation and solvent recycling will be implemented and tested
- Catalysts and operating conditions for hydroprocessing solvent liquefaction bio-oil will be determined using bench scale fixed bed micro-reactors
- Targets will be met before advancing to next tasks
 - 8 hours continuous solvent liquefaction operation
 - Production of bio-oil with oxygen content under 25%
 - 15 day hydroprocessing operation with production of biocrude with oxygen content under 2%

2 - Technical Accomplishments/ Progress/Results

- Solvent liquefaction unit has been disassembled and packaged for shipment to ISU
- All new major components have been identified, specification commenced
- Process & Instrumentation Diagrams have been updated to incorporate continuous liquid and solid separation and solvent recycle

3 - Relevance

- Supports the goal of producing bio-oil with desirable qualities for making hydrocarbon transportation fuels in the gasoline, diesel, and jet range at less than \$3 per gallon
 - Production of clean, low-cost bio-oil that can be integrated into a biorefinery to produce fuels
 - Identification of large, sustainable supply of reasonable-cost high quality biomass
- Improves commercial prospects of biomass-based transportation fuels helping to meet EISA RFS goals

4 - Critical Success Factors

- Production of thermally stable, low oxygen content bio-oil
- Demonstration of continuous operation of key unit processes – liquid fractionation, solids separation, and solvent recycle
- Cost effective catalysts and process configurations and conditions for hydroprocessing of bio-oil to refinery compatible biocrude

5. Future Work

- Current project continues until December 31, 2015
- Design and construction of system scheduled for completion in September, 2013

| Tasks | Jan-Dec 2013 | | | | Jan-Dec 2014 | | | | Jan-Dec 2015 | | | |
|--|--------------|--|--|--|--------------|--|--|--|--------------|--|--|--|
| Task 1 – Proof of concept testing of solvent liquefaction with continuous product separation and solvent recycle | | | | | | | | | | | | |
| Task 2 – Determine hydroprocessing conditions for upgrading solvent liquefaction bio-oil to refinery compatible biocrude | | | | | | | | | | | | |
| Task 3 – Preliminary design package for demonstration plant | | | | | | | | | | | | |
| Task 4 – Impact of biomass feedstock production on forest biodiversity | | | | | | | | | | | | |

Summary

- Solvent liquefaction is a promising pathway to low cost bio-oil low in oxygen content
- This project will test solvent liquefaction with continuous separation of bio-oil, char and solvent
- Key challenges include continuous operation of product separation, solvent recycle, and production of thermally stable bio-oil
- Impact of forest biomass harvesting on biodiversity will be assessed to determine availability of sustainable supply of biomass