

OFFICE OF NUCLEAR ENERGY

**NEET-ADVANCED METHODS FOR
MANUFACTURING AWARD SUMMARIES**



NUCLEAR ENERGY ENABLING TECHNOLOGIES – ADVANCED METHODS FOR MANUFACTURING
MAY 2016

Introduction

Advances in manufacturing technologies, including modular construction, improved factory and field fabrication and other innovative construction technologies, are essential to the future of nuclear energy. They are strategically important to the economics of new nuclear power plant construction in the United States and to the competitiveness of the U.S. in the nuclear energy market.

In 2012, the Nuclear Energy Enabling Technologies (NEET) Program was initiated by the Department of Energy's Office of Nuclear Energy (NE) to conduct research, development and demonstration (RD&D) in crosscutting technologies that directly support and enable the development of new and advanced reactor designs and fuel cycle technologies. Advanced Methods for Manufacturing (AMM) is one program element of NEET Crosscutting Technology Development whose focus is to improve the methods by which nuclear equipment, components, and plants are manufactured, fabricated and assembled by utilizing practices found in industries such as oil, aircraft and shipbuilding.

The NEET AMM program includes two goals:

- To reduce the cost and schedule for new nuclear plant construction
- To fabricate nuclear power plants and their components faster, more economical, and more reliable.

By evaluating state-of-the-art practices found in other large manufacturing industries, the nuclear community has identified six major areas of innovation the NEET AMM program is currently helping to advance. These innovation areas are:

1. *Welding and Joining Technologies.* New technologies focused on high speed, high quality and code acceptable welds are needed in both factory and field fabrications. Electron beam and laser welding are examples of technologies needed to join heavy section components to improve their efficiency. On-line, non-destructive testing that can provide real-time, or near real-time, feedback on the quality of the weld would improve the productivity in both the shop and the field.
2. *Additive Manufacturing.* This process, compared to subtractive manufacturing, utilizes lasers, electron beams, friction stir welding or conventional technologies to fuse thin layers of solid or powdered material in a precise two dimensional pattern to create a near-net shape component provided by computer-aided design and manufacturing (CAD/CAM) information. Additively manufactured components could provide necessary cost and schedule savings over traditionally manufactured components.
3. *Modular Fabrication.* This concept will move new nuclear reactor builds away from "piece built" fabrication and construction techniques and allow them to be built economically. The modules must be factory built, transportable, capable of precise placement, engineered to their function in their environment, and easily mated to form a single entity.
4. *Concrete Materials and Rebar Innovations.* High strength, high performance concrete and rebar will both improve the quality and reduce the construction time required for new nuclear power plants. Advancements that enable integrated prefabrication of reinforced steelform assemblies will also help to move new builds away from the traditional "stick builds".
5. *Data Configuration Management.* Complex civil and mechanical designs, and the systems they make up, need to maintain their design configuration for the duration of construction and the operational

life of the facility. Digital gathering of data and multi-dimensional data capture are tools that can help maintain that design and assist in design control when modifications are necessary.

6. *Surface Modification and Cladding Processes.* Cladding and surface modification techniques in current nuclear components are typically applied through some form of welding, a process that melts one material into another. This causes unique alloys at the interface. These material differences are the cause of many surface and sub-surface flaws. Avoiding melting, by using solid state, cold spray or other bonding processes can eliminate the welded clad problems.

The NEET AMM program is developing these advanced manufacturing technology innovations through competitive solicitations issued annually that are open to industry, academia and national laboratories. AMM is also closely involved with the DOE's Clean Energy Manufacturing Technology Team (CEM-TT), which is a cross cutting collaboration that leverages manufacturing development efforts between DOE's applied energy offices such as programs within the Offices of Nuclear Energy, Fossil Energy and Energy Efficiency and Renewable Energy.

In Fiscal Year (FY) 2011, two projects, totaling \$1,074,274, were selected through the Nuclear Energy University Program (NEUP). The first was awarded to the University of Houston for the development of an innovative seismic isolation system. The second award was given to the Pennsylvania State University for the study of laser-arc hybrid welding of thick section nickel-based alloys.

In FY 2012, four projects, totaling \$3,032,798, were awarded through the Consolidated Innovative Nuclear Research (CINR) solicitation. Two awards were given to the Electric Power Research Institute and Lockheed Martin for the development of Powder Metallurgy and Hot Isostatic Pressing (PM-HIP) and laser direct manufacturing, respectively. Purdue University was awarded to develop modular connection technologies for steel plate composite walls. Lastly, an award was given for the monitoring and control of the hybrid laser-gas metal arc welding process to the Idaho National Laboratory.

In FY 2013, two awards, totaling \$737,374, were issued through the CINR solicitation to the Georgia Institute of Technology and the University of Houston for the advancement of self-consolidating concrete and ultra-high performance concrete, respectively.

In FY 2014, three projects, totaling \$2,400,000, were selected through the CINR. The first was awarded to the University of Houston for the further development of their FY 2011 NEUP periodic material-based seismic base isolators. Oak Ridge National Laboratory was selected to improve weld productivity by creating a real-time close-looped weld monitoring system. Purdue University was awarded to evaluate accident thermal conditions and other parameters on the seismic behavior of nuclear structures. One project was also selected through the Small Business Innovation Research (SBIR) solicitation, totaling \$1,500,000. TetraVue, Inc. from San Marcos, California is looking into high speed three-dimensional data capture systems for data configuration management.

In FY 2015, four projects, totaling \$3,078,352, were issued through the CINR. Two additive manufacturing awards were given to GE Global Research and Idaho National Laboratory to investigate the irradiation resistance and stress corrosion cracking resistance on in-core components manufactured by direct metal laser melting (DMLM) and to develop novel methods for on-site fabrication of continuous large-scale structures, respectively. One award was given to Texas Agricultural & Mechanical (A&M) University to develop an advanced surface plasma nitriding technique. The University of Notre Dame will investigate the use of high-strength steel rebar, prefabrication of rebar assemblies with headed anchorages, and high-performance concrete. Three projects were also selected through the SBIR solicitation, totaling \$1,299,579. RadiaBeam Systems from Santa Monica, California will look to join austenitic steels to nickel-based superalloys through electron beam melting. Voxel, Inc. from Beaverton, Oregon was looking into data configuration management systems. And the Materials and Electrochemical Research (MER) Corporation

from Tucson, Arizona will look create built-up structures using friction stir additive manufacturing (FSAM), using a non-consumable tool.

Since 2011, the AMM program has awarded a total of \$13,122,377 to 19 projects. These open, competitively selected awards have already begun to make significant progress in the advancement of manufacturing technologies. Each year, the participation in the solicitations has grown to include more partnerships and include a more diverse selection of industries applying their technology to the nuclear energy sector. In the following sections, it will be seen that the developments and innovations continue to surpass the expectations of the NEET AMM program.

FY 2012-2015 NEET-AMM Award Summaries

Beginning in FY 2012, proposals were sought to pursue innovative methods to manufacture or fabricate components faster and with better quality; and to improve factory assembly and field deployment of plant modules, thereby reducing the cost and schedule requirements for new nuclear plant development. Specific goals include:

- Accelerate deployment schedule by at least 6 months compared to current new plant construction estimates;
- Reduce component fabrication costs by 20% or more;
- Increase installation of key subsystems without cost increase or schedule delay.

The program requested to develop manufacturing and fabrication innovation, assembly processes and materials innovation that support the “factory fabrication” and expeditious deployment of reactor technologies. Potential areas for exploration include:

- Factory and field fabrication techniques that include strength assistance tooling, advances in verification of designed configuration, improvements in manufacturing technologies such as advanced (high speed, high quality) welding technologies, practical (shop floor) applications of electron beam welding for fabricating heavy sections, surface modification and metal spraying techniques that reduce erosion, corrosion and wear on component surfaces.
- Assembly and material innovation to enhance modular building techniques such as advances in high performance concrete and rebar, design innovation using concrete composite and steel form construction methods, inspection processes and equipment, and innovative rebar pre-fab and placement systems. Innovations in concrete materials or design of structures that can reduce the total volume of concrete poured or the overall thickness of concrete sections are relevant to this program.
- Advances in manufacturing processes for reactor internals, fuel cladding and fuel support assemblies. Research could include advanced manufacturing methods for individual components or fabrication of assemblies. Cladding or surface modification methods to resist corrosion and wear are relevant to this research topic.
- Improved concrete inspection, measurement and acceptance technology, techniques and methods to facilitate the pour and curing of nuclear plant concrete.

Innovative Manufacturing Process for Nuclear Power Plant Components via Powder Metallurgy-Hot Isostatic Pressing

D. Gandy, B. Sutton, S. Summe, Electric Power Research Institute

M. Connor and J. Robinson, GE-Hitachi

S. Lawler, Rolls Royce

L. Lherbier and D. Novotnak, Carpenter Powder Products

Funding: \$800,000 (10/01/2012 - 03/30/2016)

Description of project: For more than 60 years the nuclear power industry has relied on structural and pressure retaining materials produced via established manufacturing practices such as casting, plate rolling-and-welding, forging, drawing, and/or extrusion. The current project is aimed at the development and introduction of another process, powder metallurgy and hot isostatic pressing (PM-HIP), for the manufacture of near-net shaped (NNS) reactor pressure internal and external components. The RD&D project has been focused on the manufacture and assessment of large components from three alloy families: low alloy steel, stainless steels, and nickel-based alloys to both demonstrate and assess the technology for future use in nuclear applications.

Impact and Value to Nuclear Applications: Powder metallurgy technology integrated with advanced alloy modeling/design capabilities, and state-of-the-art HIP technology, can have a significant impact on the energy industry's goals to lower manufacturing costs and energy consumption, shorten production schedules by up to 6 months, and reduce emissions. Specific benefits of manufacturing near-net shaped (NNS) components via PM/HIP include: increased material utilization (resulting in reduced machining and fabrication costs), material cost reduction, elimination of welding repairs, and a significant improvement in the inspectability of components. This research will have a tremendous impact as we move forward over the next few decades on the selection of new alloys and components for advanced light water reactors and small modular reactors. Furthermore, fabrication of high alloy materials/components may require the use of new manufacturing processes to achieve acceptable properties for higher temperature applications such as those in Generation IV applications.

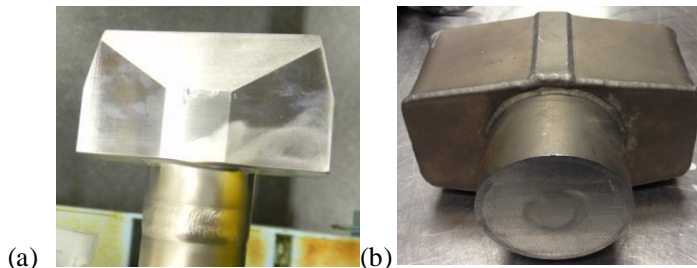

Figure 1. (a) shows the current manufacturing process for a chimney head bolt, (b) provides a similar part which has been produced via PM-HIP. Note: the carbon steel “can” shown in Figure 1b would be removed by pickling.

Recent Results and Highlights: In 2015, manufacturing efforts continued toward producing a ring section for a reactor vessel along with a nozzle from 508 Class 1, Grade 3 steel. The development involved the production of five additional 300lb test heats of 508 powder, consolidation of the powder into small test blocks, and mechanical and microstructural characterization. The optimum heat of material was selected and a ring section is planned for early 2016. An assessment of stress corrosion cracking and crack growth characteristics for PM-HIP materials including 316L stainless steel and Alloy 600M was completed. The assessment evaluated the two PM-HIP alloys along with two wrought materials under both boiling water reactor (BWR) and pressurized water reactor (PWR) coolant chemistry conditions in three different product forms: as-received, 20% cold worked, and heat affected zone. In all cases, the PM-HIP alloy performed in a very similar manner to the wrought product form indicating that PM-HIP should perform quite well in BWR/PWR environments. In addition, an Alloy 600M chimney head bolt, a component used in the Advanced-Economic Simplified Boiling Water Reactor (ESBWR), was manufactured via PM-HIP. The current design for the chimney head bolt utilizes a forged head which is machined and then welded to a round shaft from the same alloy (see Figure 1a). This is very time consuming and adds an unnecessary weld joint. Manufacture of the part from PM-HIP allows the part to be produced to near-net shape requiring only finish machining to size, saving considerable hours in both fabrication and pounds (kilograms) of material required. The final PM-HIP part is shown in the Figure 1b just prior to removal of the “can” used during the HIP process.

FY 2013 Projects

Self-Consolidating Concrete Construction for Modular Units

Drs. Russell Gentry, Kimberly Kurtis, Bojan Petrovic, Lawrence Kahn and

Giovanni Loreto, Georgia Institute of Technology

Jurie Van Wyk and Carlos Cantarero-Leal, Westinghouse Corporation

Funding: \$400,000 (02/01/2014 – 04/30/2016)

Description of Project: The primary objective of this project is to develop a unique concrete with self-roughening and self-consolidating properties, so that concrete can be placed into steel plate composite (SC) modular reactor structures without the need for continuous concreting operations. The self-roughening aspect of the material allows for concrete placement to stop and restart later, as the concrete develops a self-roughened surface that can transmit shear forces across the so called “cold-joint”. As part of the research, concrete mixtures are being developed and validated to ensure sufficient shear capacity across cold-joints, while minimizing shrinkage and temperature rise during concrete curing. A small-scale test article has been developed to assess the in-plane shear capacity of SC construction across the cold joint. This will allow us to assess a wide range of concrete material properties and steel plate configurations. Larger-scale beam specimens will be tested with in-plane and out-of-plane loading to confirm the small-scale test findings. One full-scale test, on an SC wall-section provided by Westinghouse, will be completed to validate the scale models. The team will propose code provisions for shear friction for the AISC N690 Appendix N9 code used for the design of SC modular reactors.

Impact and Value to Nuclear Applications: This new concrete will improve the construction and economy of modular reactor systems by facilitating the concrete construction while assuring high quality bonding of concrete and composite steel elements. This will be achieved through innovations in the composition and properties of the self-roughening, self-consolidating concrete, where mixtures and processes are optimized to overcome challenges of cold-joint shear capacities, while also addressing heat generation and shrinkage at cold joints. Updates to the SC design code and concrete specifications will allow engineers to use these new materials and construction sequencing in future SC reactor construction.



(a)

(b)

Figure 1. Cold-joint failure mode in out-of-plane bending. Failure occurs as steel studs on the tension side of the specimen shear from the steel plate.

Recent Results and Highlights: The behavior of cold-joints in SC construction has been explored through the testing of mid-size specimens receiving either in-plane or out-of-plane loadings. Initial tests on specimens having cold joints with insufficient aggregate interlock (see Figure 1) demonstrate potential structural problems that can occur at cold-joints. The final mid-scale (Task 3) and full-scale (Task 4) tests apply the same loading regimes on properly-placed self-roughening concrete – and will form the basis for our proposed revisions to AISC N690 Appendix N9.

FY 2014 Projects

Improving Weld Productivity and Quality by means of Intelligent Real-Time Close-Looped Adaptive Welding Process Control through Integrated Optical Sensors

Jian Chen, Roger Miller, Zhili Feng, ORNL, Oak Ridge, TN 37831

Yu-Ming Zhang, University of Kentucky, Lexington, KY 40506

Robert Dana Couch, EPRI, Chattanooga, TN 37405

Funding: \$800,000 (10/01/2014 – 09/30/2017)

Description of Project: This project aims at developing a novel close-looped adaptive welding quality control system based upon multiple optical sensors. It will enable real-time weld defect detection and adaptive adjustment to the welding process conditions to eliminate or minimize the formation of major weld defects typically encountered in welding of high-performance engineering structural materials for nuclear structural components. The multi-optical sensing system mainly consists of a visible (VIS) camera, an infrared (IR) camera, a weld pool surface measurement sensor and the necessary auxiliary illumination sources and filters. The sensing system will be capable of simultaneously measuring, in real-time, the changes in the welding temperature field via IR camera, the strain field based on digital image correlation (DIC) via VIS camera, and the dynamic changes of weld pool surface. The measurement signals will be correlated to the weld quality and provide feedback control of the welding processes.

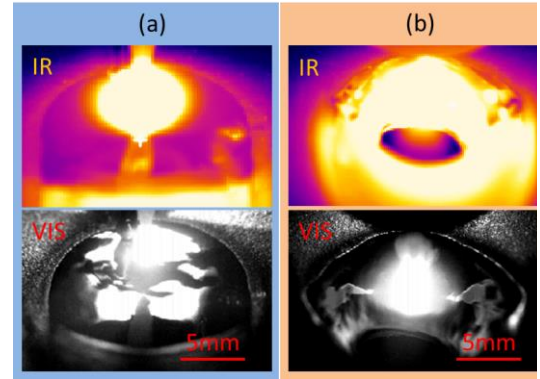

Figure 1. Weld pool visualization using collimated IR and VIS cameras: (a) full penetration and (b) burn-through defect

Impact and Value to Nuclear Applications: In today's industry, the weld quality inspection for manufacturing nuclear reactor structures mostly relies on post-weld NDE techniques. If a defect is identified, the reworking (or scrapping if beyond repair) of manufactured structures are costly and time-consuming for the thick-section reactor structures. The multi-sensing system monitors and controls the weld quality in real time. By drastically reducing weld defects and therefore the rework required for defect mitigation, the on-line system can significantly decrease the component fabrication cost, accelerate the deployment schedule, and increase the integrity and reliability in a variety of nuclear reactor designs and components.

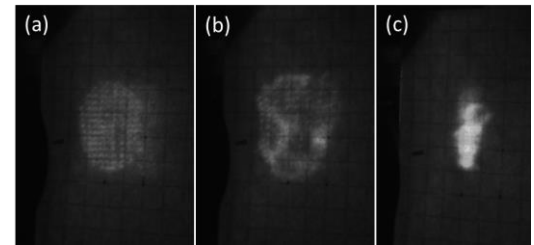

Figure 2. Laser reflection based weld pool surface monitoring: (a) partial penetration, (b) full penetration and (c) large penetration

Recent Results and Highlights: The multi-sensing system including hardware, software and algorithms has been integrated and tested in various welding conditions. The weld pool can be monitored by a collimated IR and VIS camera system as shown in Figure 1. When certain defects occur (e.g. burn-through defect in Figure 1b), the thermal and visible characteristics of the weld pool are clearly different from those of defect-free welds (Figure 1a). By using the laser reflection based weld pool sensor, the change of the reflection patterns can also be correlated to the transition of a weld from partial to full penetration (Figure 2). A special algorithm has been developed to determine, in real time, the evolution of both strain (Figure 3) and stress adjacent to the fusion line from the DIC measurement.

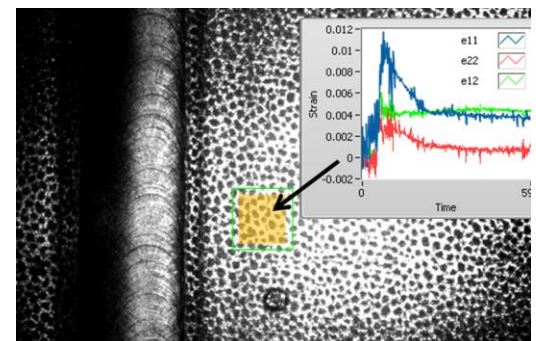

Figure 3. Real-time non-contact strain monitoring based on DIC

Improvement of Design Codes to Account for Accidental Thermal Effects on Seismic Performance

A. H. Varma, Purdue University, West Lafayette, IN 47906

Funding: \$800,000 (10/01/2014 – 09/30/2017)

Description of Project: The Fukushima nuclear accident of 2011 has highlighted the importance of designing safety-related nuclear facilities for accident thermal scenarios combined with design basis and beyond design basis shaking. While the probability of both events occurring simultaneously is low, severe environmental conditions may trigger accident thermal loading. Furthermore subsequent aftershocks, potentially as intense as the main shock, may occur during the accident thermal event. Current design codes and standards in the United States and abroad provide little-to-no guidance for including the effects of accident thermal loading on seismic behavior (stiffness, strength, ductility or reserve margin) of structures. *The overall goal of this research project is to develop knowledge-based design guidelines for safety related nuclear facilities subjected to combined accident thermal conditions and seismic loading.*

Impact and Value to Nuclear Applications: The results from the experimental and analytical investigations will be used to develop design guidelines and recommendations for steel plate composite (SC) and reinforced concrete (RC) walls subjected to combined accident thermal loading and earthquake shaking, including design basis (SSE) and beyond design basis shaking.

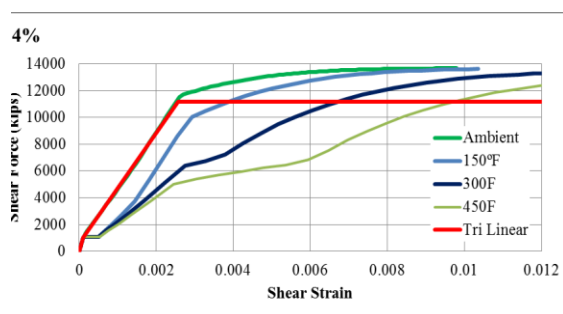

Figure 1. Shear force vs. shear strain comparisons of SC panels at different thermal loading

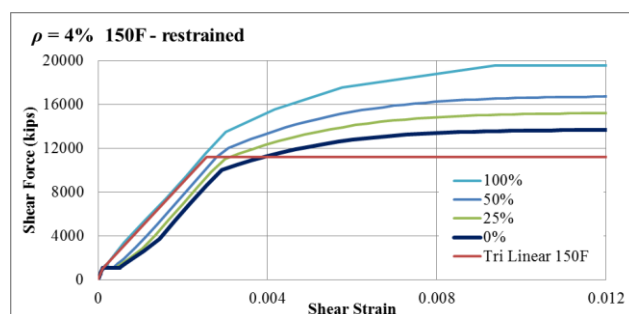

Figure 2. Shear force vs. shear strain comparisons of SC panels with different restraint conditions

Recent Results and Highlights: Preliminary numerical studies were conducted on SC and RC walls to be used for development and benchmarking of the experimental program. The numerical studies were presented and published at the 23rd Structural Mechanics in Reactor Technology Conference (SMiRT 23). The numerical studies included models that were built for predicting the nonlinear inelastic behavior of SC walls subjected to thermal loading and monotonic lateral loading. The preliminary models were benchmarked using the experimental data obtained in the literature from tests of in-plane shear behavior SC walls with and without thermal loading. The models were analyzed using sequentially coupled thermal-mechanical analysis approach. The analysis results of this study show that the faceplate reinforcement ratio, temperature amplitude and edge restraints have remarkable influence on the behavior of SC walls as shown in Figures 1 and 2. The numerical studies also included evaluations of design force demands of RC walls for safety-related nuclear structures due to accident thermal loads. Thermal loading conditions and effects of thermal loads and restraints on the structural behavior are discussed. Idealized possible structure geometries for nuclear facilities were analyzed and the modeling and analysis parameters were briefly discussed. Demand to capacity ratio (DCR) for individual demands were also calculated. The DCRs from linear elastic finite element (LEFE) and non-linear inelastic finite element (NIFE) analysis were compared to predict the effectiveness of simple LEFE analysis.

Periodic Material-Based Seismic Base Isolators for Small Modular Reactors

Y. L. Mo, University of Houston, Houston, TX

Y. Tang, Argonne National Laboratory, Argonne, IL

R. Kassawara, Electrical Power Research Institute, Charlotte, NC

K. C. Chang, National Center for Research on Earthquake Engineering, Taipei, Taiwan

Funding: \$800,000 (10/01/2014 – 09/30/2017)

Description of Project: The research seeks to develop a periodic foundation for small modular reactors (SMR) using innovative periodic material. This material is inspired by the concept of phononic crystal in solid-state physics. This material has a distinct deficiency; it lacks certain frequency bands, known as frequency band gaps, which allow elastic waves to pass through if the frequencies of the waves fall into these gaps. This deficiency, however, is a much needed feature for seismic base isolation systems. With a proper design, the periodic foundation will be able to block incoming seismic waves, preventing them from reaching the superstructure. The focus of this research is placed on the design phase of periodic foundations for the SMR building. The design procedure developed will be validated by shake table tests using real, recorded earthquake ground motion.

Impact and Value to Nuclear Applications: The value of periodic material for SMR foundation applications is two-fold. First, it reduces the seismic motion transmitted to the superstructure so that standardization of nuclear power plant design is feasible. Second, it eliminates the need for a moat surrounding the isolated structure which is required by the conventional seismic isolation systems, such as the rubber bearing and friction pendulum system. This not only reduces construction cost but also avoids the hassle related to the design of utility lines crossing the moat.

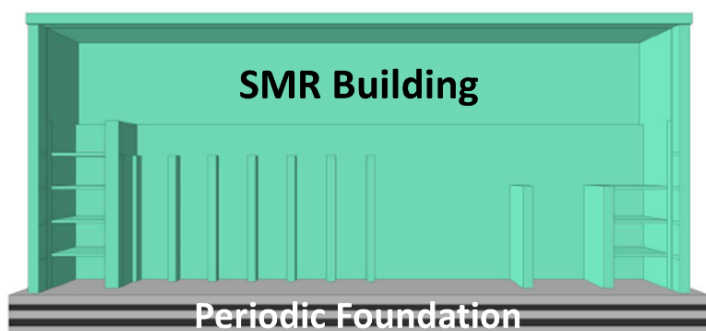

Figure 1. SMR building on periodic foundation

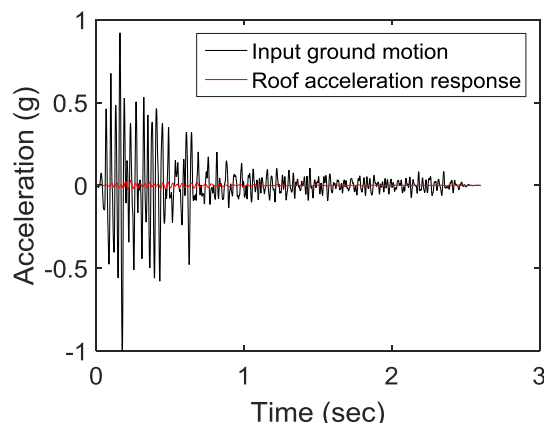

Figure 2. Acceleration response of SMI building with periodic foundation model

Recent Results and Highlights: Information regarding the specification of the SMR building has been obtained from a reputable SMR company. The SMR building serves as the case study for this project. A full scale one dimensional (1D) periodic foundation was designed to isolate the SMR building from the incoming seismic waves. The cut view of the SMR building sitting on the periodic foundation is shown in Figure 1. In order to fit the shake table facility, the prototype structure system was scaled down according to the similitude requirements. Figure 2 shows the preliminary analysis of the scaled down model. The acceleration on the roof of the SMR building model is reduced significantly compared to the input ground motion. The first test specimen with a 2D periodic foundation is currently under construction. The second test specimen with three dimensional (3D) periodic foundation is currently under design process.

High Speed 3D Data for Configuration Management

Paul Banks, TetraVue, Carlsbad, CA 92010

Funding: \$1,500,000 (7/28/14 – 7/28/16)

Description of Project: This Small Business Innovative Research project intends to demonstrate the feasibility of achieving engineering-grade, three-dimensional (3D) as-built models from a high resolution 3D video input stream. This concept of video acquisition rather than scan and survey acquisition promises the potential of changing the weeks of capture and processing time currently required for 3D laser scanners to days or less. This improvement can be accomplished by eliminating time-consuming setups and post-processing needed for static 3D capture. For this project, an improved prototype 3D camera has been constructed to be used in handheld operation in congested plant areas. In addition, the software processing pipeline is being optimized to achieve the engineering-grade accuracy from data intrinsic in the high resolution 3D data (no fixed reference points required).

Impact and Value to Nuclear Applications: Construction of complex facilities, such as nuclear power plants, has evolved to require sophisticated processes and data management capabilities to help ensure that the plants as constructed will perform as designed throughout their life cycle. A key element in realizing the value of a Configuration Management or Building Information Model approach is the ability to track all design elements and to update the design when there is a deviation between the design and the as-built. This tracking process requires detailed, accurate measurements of the facility and all of its components. Historically, such documentation has been costly, even with the current technology of 3D laser scanning. Using a video-capture approach to acquire fast as-built 3D information has the potential to reduce the cost of and improve the time-to-access 3D data.

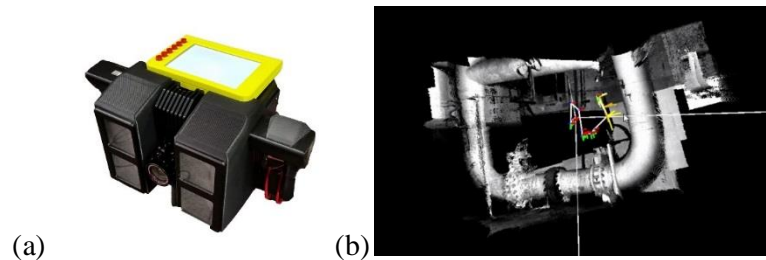

Figure 1. Phase II handheld 3D video camera (a) will be coupled with optimized registration software to create near real-time as-built models of large plant areas. Preliminary testing with DotProduct's Phi3D software created a registered point cloud (b) in less time than it took to take the data (4 sec registration for 10 sec of data).

Recent Results and Highlights: TetraVue has completed construction of an improved 3D camera prototype to better meet the requirements of collecting the 3D as-built information of a construction project or existing plant. The resultant handheld camera is shown in Figure 1, a handheld 3D camera that has an integrated display to show the status and 3D data as collected and controls typical of a camcorder. No work has been performed for electronics miniaturization so the handheld unit is still quite heavy (10 lb), requiring two-hand operation. The 3D data stream and greyscale video are available on the camera display in real-time. In 1 hour, the camera can collect data on 72,000 m² with 90% overlap. These data streams are the input to camera tracking and registration software such as simultaneous localization and mapping algorithms (SLAM). Data accuracy of automatic SLAM is being improved with the high resolution, long-range 3D video data, but real-time registration has already been shown (Figure 1).

FY 2015 Projects

Prefabricated High-Strength Rebar Systems with High-Performance Concrete for Accelerated Construction of Nuclear Concrete Structures

Y.C. Kurama and A.P. Thrall, University of Notre Dame

S.E. Sanborn, Sandia National Laboratories

M. Van Liew, AECOM

Funding: \$800,000 (10/01/2015 - 09/30/2018)

Description of Project: This project aims to reduce the field construction times and fabrication costs of reinforced concrete (RC) nuclear safety-related reactor building structures through the use of: 1) high-strength steel deformed reinforcing bars (rebar); 2) prefabricated rebar assemblies with headed anchorages; and 3) high-strength concrete. The focus of the project is not to develop new innovations on materials, but rather to fill a major knowledge gap on the effectiveness, code conformity, and viability (i.e., practicality, commercial availability) of the application of existing high-strength materials in nuclear structures, especially in stocky shear walls since they are the most common lateral load resisting members in non-containment nuclear structures.

Impact and Value to Nuclear Applications: The envisioned advances will result in generalized outcomes with reduced volumes/complexities of rebar (fewer/smaller bars and bar layers) and approaches for prefabrication. This will reduce costs of materials/fabrication, facilitate concrete placement, reduce construction times, and improve construction quality and ease of inspection.

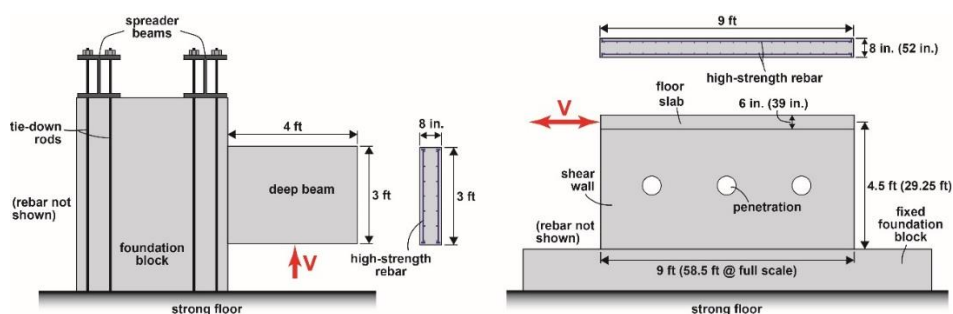

Figure 1. Preliminary Elevation and Cross-Section Views of Deep Beam Specimens (Left) and Capstone Shear Wall Specimens (Right)

Recent Results and Highlights: Experimental testing will occur on two types of specimens (Figure 1): 1) deep cantilever beams (representing slices out of a wall length) to understand the effects of various fundamental design parameters (e.g., concrete strength, reinforcing steel strength, reinforcement ratio, moment-to-shear ratio) on the shear and flexure-shear behavior of stocky RC shear walls with high-strength materials; and 2) capstone shear walls to understand the behavior of more complete specimens subject to reversed-cyclic flexure-shear loading. The properties of the test specimens have been determined based on ranges of building properties from available design control documents maintained by the U.S. Nuclear Regulatory Commission and discussions with industry representatives. Testing of the beam specimens will begin in the summer of 2016.

The project has also begun a limit-benefit analysis of high-strength materials for use in RC nuclear shear walls. A parametric numerical study has been conducted to determine the effects of high-strength rebar and concrete on the lateral strength of shear walls with a wide range of properties. The construction cost and time savings that can be achieved through the use of high-strength materials are being evaluated.

Advanced Surface Plasma Nitriding for Development of Corrosion Resistant and Accident Tolerant Fuel Cladding

Lin Shao, Frank Garner, Texas A&M University, College Station, TX 77843

Don Lucca, Oklahoma State University, Stillwater, OK 74078

Michael Short, Massachusetts Institute of Technology, MA 02139

Funding: \$800,000 (10/01/2015-09/30/2018)

Description of Project: Although various surface coating techniques have been proposed to increase the oxidation and corrosion resistance of fuel cladding materials, the de-bonding of the coating layer with the original cladding matrix under exposure to coolants makes such approaches unsuitable for reactor applications. Furthermore, the feasibility of techniques for large scale processing on cladding tubes remains another technological bottleneck. This project aims to develop a hollow cathode plasma nitriding technique to form nitride layers on alloys of irregular shapes without an edging effect, an issue encountered in traditional plasma nitriding processes, and is suitable for surface processing of other in-core components. As opposed to vapor deposition techniques, the nitriding process directly converts the surface of cladding tubes into a nitride layer, without the risk of de-bonding. Various microstructural characterizations and mechanical property measurements will be performed to test the developed layer. For outside surfaces, samples will be tested in high temperature water and liquid sodium coolant loops to evaluate their corrosion resistance and compatibility with coolants for LWR and fast reactor applications.

Impact and Value to Nuclear Applications: In harsh reactor environments fuel cladding materials are subjected to high stress, high corrosion and high irradiation damage, resulting in severe structural changes and degradation, which impacts not only lifespan but also reactor safety and reliability. Development of advanced fuel cladding materials is critical for both present designs with extended life times and advanced designs with even harsher operating conditions. Although numerous studies have shown that a surface nitride layer can be used to increase hardness, wear resistance, oxidation resistance, and corrosion resistance, there has not been a systematic investigation pertaining to nitriding effects on fuel cladding materials, particularly when neutron damage and fuel cladding interactions must be considered. Furthermore, existing plasma nitriding techniques are not able to uniformly modify a hollow tube.

Recent Results and Highlights: The project has finished the first main task on system optimization. Plasma is preferentially formed at the cross welds of the cage due to the intense electric field at these points. This results in the cross welds having a high temperature which results in sputtering. As the temperature increases, the sputtering increases and arcing increases to these cross welds. To prevent arcing due to hot spots in the chamber, a wire mesh is placed inside the chamber which is grounded to the chamber resulting in the anode plasma being formed on the mesh. Systematic nitridation experiments were performed on pure Fe and pure Zr. Experiments were extended to complex stainless steels and zircaloy. Microstructural characterization was performed to identify the governing factors which determined nitride phases, nitride morphology, and nitride layer thickness as a function of pressure, temperature and plasma energy. Both nitriding chamber setup and nitriding parameters were optimized for better quality control. The next step is to study thermal stability of nitride phases. After that, ion irradiation, mechanical property measurements and corrosion testing will follow.

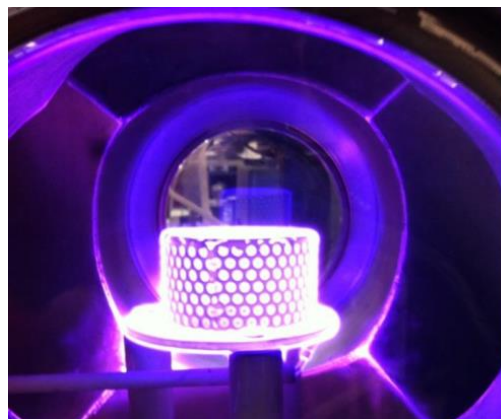

Figure 1. A picture of the plasma nitriding device under operation. The device was custom-built at Texas A&M University.

Advanced Onsite Fabrication of Continuous Large-Scale Structures

Corrie I. Nichol, Idaho National Laboratory, Idaho Falls, Idaho 83415

Funding: \$799,309 (10/01/15-09/30/18)

Description of Project: Large structures such as pressure vessels and containment structures for gigawatt sized reactors present significant transportation challenges, as do pressure vessels and even containment vessels for small modular reactors (SMR). This limits their placement to areas accessible by navigable water ways. This project is conducting initial development work toward a novel method for on-site fabrication of continuous large-scale structures such as pressure or containment vessels.

Impact and Value to Nuclear Applications: This project seeks to leverage the benefits of additive manufacturing in reactor fabrication. Potential benefits include the ability to fabricate vessels from metal matrix composites, or a base material with clad metal structures. This process also enables raw materials to be brought to the construction site in an easily transportable form, where they are melted prior to or during the spraying process. This also eliminates the need to weld multiple small sections to form the vessel, eliminating the potential to form undesirable tensile residual stress states at welded interfaces.

Recent Results and Highlights: In spray-forming, molten metal droplets are entrained in a gas jet and transferred to a surface where it rapidly solidifies. This process is capable of rapid material deposition rates. This project will focus on the development of proof-of-concept hardware and the investigation of deposition rates and interpass parameters. This will utilize a dual arc spray deposition system (the Praxair TAFE 9910i CoArc Arc Spray System) for initial investigation of deposition parameters and process control. This process is similar to the spray-forming process, and will be able to replicate the temperature of sprayed droplets, droplet velocity, and particle size, but with lower material deposition rates. The small-scale arc spray work will be conducted in an enclosure with appropriate filtration and air flow required in a spray deposition process. A 3-axis gantry robot will be leveraged for control and movement of the spray deposition head.

In parallel to the development work with the surrogate process discussed, an initial investigation into the energy requirements of a fully functional benchtop continuous spray forming based material deposition system has been considered. Initial calculations assumed material spray deposition rates on the order of 0.5kg/min, and spraying a 300 series stainless alloy (in this case, 304 stainless). Past research shows material deposition efficiencies of between 0.5 and 0.8, i.e. between half and 80% of material sprayed from a spray gun will deposit and solidify on the substrate, resulting in an actual material deposition rate of between 0.25 and 0.4 kg/min.

For a spray forming process, in addition to melting the metal alloys, a gas pre-heater is also necessary. The mass flow ratio of metal to gas of 0.3 was used for these calculations, based on published spray forming experiments. The rough calculations show that a heating system for metal melting will require roughly 10.5kw of energy input, and the gas pre-heater will use roughly 15-30kw, based on calculations for argon or nitrogen carrier gasses, respectively. These calculations demonstrate rough calculations of expected energy consumption for a bench-top system. The surrogate process selected is less energy efficient, but will enable a much more rapid setup and development cycle, and as stated previously, the material sprayed can be made to look very similar to that sprayed from a spray forming process.

The arc-spray system will initially be used as supplied with air as the carrier gas. This will likely result in a higher rate of oxide inclusion, but research will be conducted to develop an inert gas delivery system for the arc spray system, reducing the amount of oxide in the final product. Ultimately the use of an available commercial system as a surrogate will enable more rapid development of the process, and demonstration of the limitations and advantages of the concept.

Environmental Cracking and Irradiation Resistant Stainless Steel by Additive Manufacturing

Xiaoyuan Lou, General Electric Global Research, Niskayuna, NY 12309

Funding: \$678,352 (10/01/2015 – 09/30/2017)

Description of Project: The nuclear industry is evaluating the potentials to deploy metal additive manufacturing (AM) technology to fabricate reactor internal components due to its unique capability to construct complex geometries and short delivery time. The major objective of this program is to access the nuclear specific properties (stress corrosion cracking (SCC) and irradiation) of the stainless steel fabricated by direct metal laser melting (DMLM) and develop improved stainless steel with enhanced SCC and irradiation resistance. As part of the team, General Electric Hitachi Nuclear Energy (GEHN) will facilitate the fabrication and evaluation of a prototype reactor component to demonstrate both schedule and cost savings. The data generated by this program will contribute to the nuclear specification development for additive manufacturing, lay out business plans for regulatory approval and commercialization.

Impact and Value to Nuclear Applications: The technology under development can provide the capability to rapidly fabricate custom designed parts that may be required during plant refueling outages. It can also provide its unique capability to generate complex geometries rapidly with improved performance for new component design. The technology will also reduce the overall component cost, plant asset management cost and increase the plant's reliability by improvement in the material's performance. The program will assist General Electric Company (GE) to evaluate and commercialize additive manufacturing technology in its nuclear business. The fundamental understanding of the relationship between microstructure, SCC and irradiation properties can advance the knowledge in materials science and impact a much broader community.

Recent Results and Highlights: Up to date, the program has developed the fundamental understanding of mechanical properties, SCC and corrosion fatigue behaviors of GE's baseline heat of additive 316L stainless steel. Preliminary understanding of the relations between microstructure and nuclear specific properties has been established. The team at the University of Michigan is currently working on evaluating the irradiation assisted stress corrosion cracking behavior of the baseline heat. The teams at GE and Oak Ridge National Laboratory are working together to optimize the laser process, powder chemistry and heat treatment to control the material's microstructure and composition which will improve SCC and irradiation resistance. The mechanistic understanding and data generated from this program are facilitating GEHN's activity on the commercial development on additive manufacturing technology.

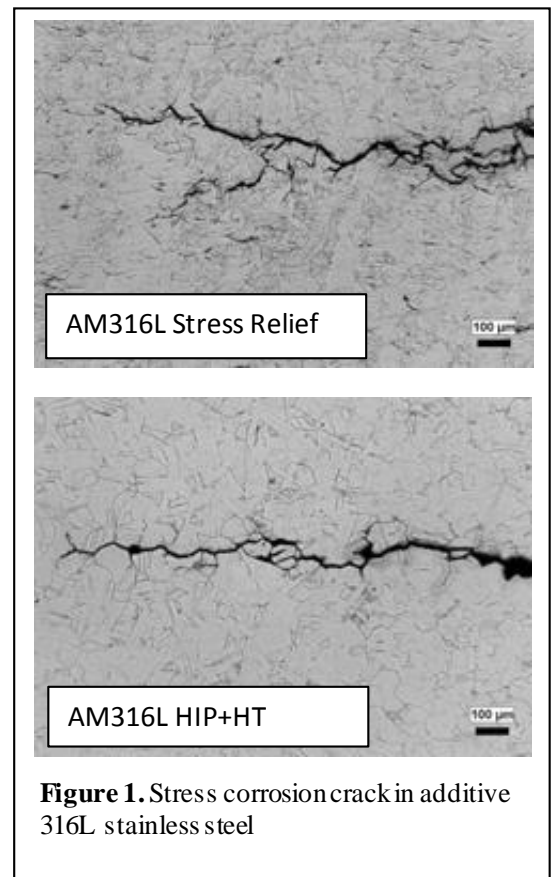

Figure 1. Stress corrosion crack in additive 316L stainless steel

Friction Stir Additive Manufacturing (FSAM) for Gradient structures for Small Modular Reactors

James Withers, MER Corporation

Rajiv Mishra and Sundeep Mukherjee, University of North Texas

Funding: \$150,000 (07/01/2015 – 03/31/2016)

Description of Project: Additive manufacturing (AM) promises a direct path from component design to manufacturing, drawing inspiration from powder metallurgy and fusion-welding based techniques. However, the issues with cast microstructure that result from traditional fusion welding based additive techniques have remained, particularly in severe operating environments such as nuclear power plants. In this context, friction stir additive manufacturing (FSAM), which is a solid-state AM process, stands apart because of several advantages it offers over conventional AM techniques. The overall goal of this project is to create built-up structures using FSAM, using a non-consumable tool to give near-net 3D shape as shown in Figure 1a. All the tasks in this project were carried out on high-temperature 92 grade steel and MA956, a highly creep-resistant oxide dispersion strengthened steel. This could potentially be an enabling concept for working on pipes and hollow structures in nuclear energy applications as shown in Figure 1b.

Impact and Value to Nuclear Applications: Materials used in different parts of a nuclear reactor experience varying level of thermo-mechanical stresses. The longevity of components in a nuclear reactor is largely dependent on the materials and processes used to integrate them into a unitized structure. The synergy between 92 grade steel and MA956 is expected to increase performance and therefore life of the nuclear component. FSAM could potentially result in significant improvement of creep and high temperature corrosion resistance of weak points such as welded joints.

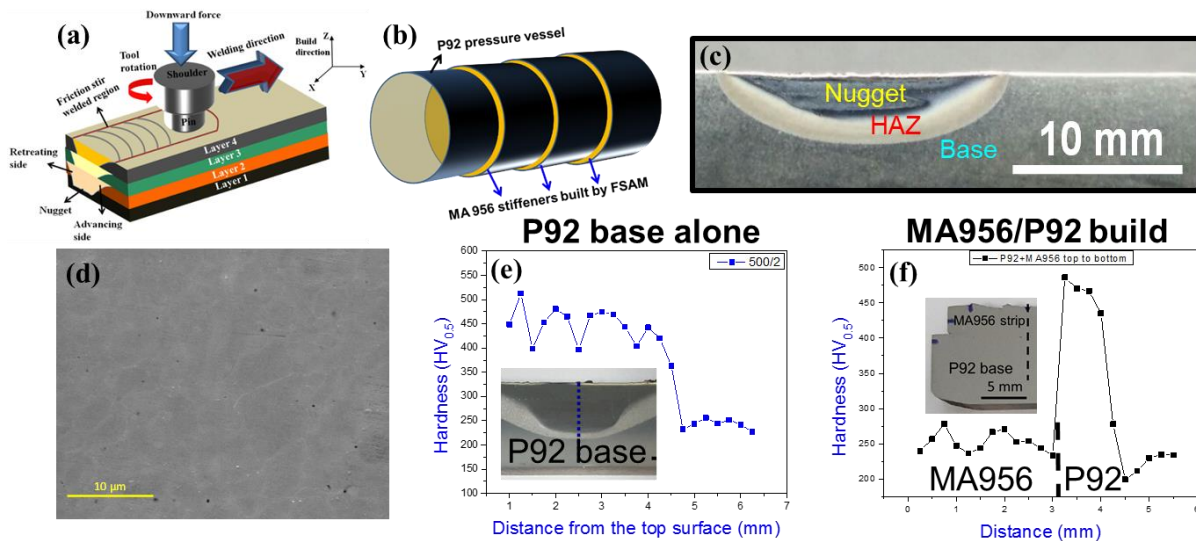

Figure 1: (a) A schematic illustration of friction stir additive manufacturing process; (b) synergistic combination of MA956 stiffeners to P92 steel pressure vessel pipes; (c) cross section of the processed region showing nugget, heat affected region (HAZ) and base; (d) microstructure of the processed region; (e) doubling of hardness along vertical axis, and (f) hardness along vertical axis in a MA956/P92 build.

Recent Results and Highlights: To date, several friction stir runs have been made on 92 grade steel and MA956. A typical cross-section image after friction stir run on P92 is shown in Figure 1c. The processed regions in P92 were analyzed to understand the changes in microstructure. The nugget region showed significantly refined grain structure with narrow network of cementite (Figure 1d). This resulted in doubling of hardness compared to the base material along the vertical axis and horizontal axis as shown in Figure 1e. Figure 1f shows a defect-free side of the MA956/P92 build (advancing side had defect). Future work will involve scaled-up manufacturing to create large sections of creep-resistant components/structures as well as fundamental scientific understanding of microstructure evolution and mechanical behavior.

Development of Nuclear Quality Components using Metal Additive Manufacturing

P. Frigola, RadiaBeam Systems, LLC

A. Hinojos, J. Mireles, L.E. Murr, R.B. Wicker, W.M. Keck Center for 3D Innovation, University of Texas at El Paso

Peter Hosemann, A. Reichardt, Department of Nuclear Engineering, University of California at Berkeley

Funding: \$999,579 (07/28/2015 to 07/27/2017)

Description of Project: A major challenge in manufacturing nuclear reactor components is the joining of dissimilar materials. This project aims to optimize and commercialized electron beam melting (EBM) additive manufacturing (AM) process for joining austenitic steels to nickel-based superalloys, as well as develop the capability (using EBM AM) to efficiently join ferritic to austenitic steels components for use in the nuclear power industry. The use of EBM AM can help avoid the use of filler materials, provides an evacuated processing environment resulting in limited contamination of oxides and nitrides, and can provide a high quality metallurgical joint while minimizing the thermal damage to surrounding material.

Impact and Value to Nuclear Applications: The successful completion of this project will allow new advancements in directed EBM AM of multi-materials and welding of dissimilar metal alloys. This technology is directly applicable to the nuclear industry, as well as some of the largest industries around the world. EBM AM has the potential to vastly accelerate innovation, compress supply chains, minimize materials and energy usage, and significantly reduce waste. Figure 1 is an overview of the process to achieve multi-material parts starting from a precursor powder material.

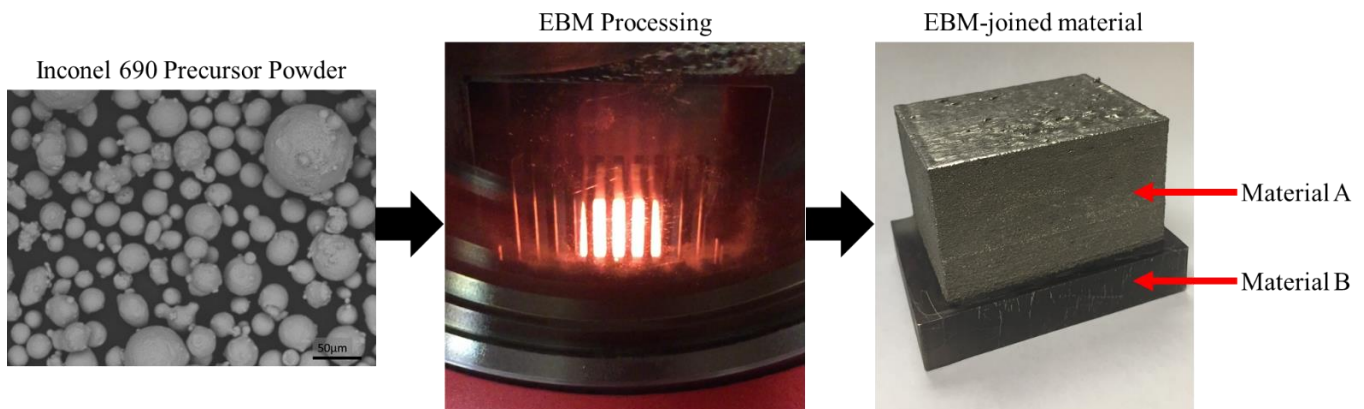

Figure 1. Joining process for non-standard materials

Recent results and Highlights: Multi-material components were fabricated using EBM AM, and the joint interfaces characterized. Joining of Inconel 718 with 316L Stainless Steel, carried out in the initial phase of this project, has been recently characterized revealing minimal thermal effects from the EBM AM process and finer weld joints. This work was recently published [A. Hinojos, et. al., *Material & Design*, Vol. 94, 15 March 2016, pages 17-27].

Inconel 690 feedstock powder has been procured, characterized, and validated for use in EBM AM. New EBM AM process parameters have been developed for joining of Inconel 690 to 316L Stainless Steel, and samples suitable for metallographic characterization have been fabricated.

EBM AM continues to show excellent promise for the efficient production of multi-material parts with improved joint qualities when compared to traditional welding processes.

Completed Projects

Projects listed below have been completed and summaries can be found in previous AMM Award Summaries available on the DOE-NE Website.

FY 2012

- Monitoring and Control of the Hybrid Laser-GMAW Process, Idaho National Laboratory, \$800,000, 10/01/2012 – 09/30/2015
- Laser Direct Manufacturing of Nuclear Power Components Using Radiation Tolerant Alloys, Lockheed Martin, \$639,889, 10/01/2012 – 09/30/2015
- Modular Connection Technologies for Steel plate Composite Walls of Small Modular Reactors, Purdue University, \$792,572, 08/15/2012 – 12/31/2015

FY 2013

- Ultra-High-Performance Concrete and Advanced Manufacturing Methods for Modular Construction, University of Houston, \$399,999, 01/15/2014 – 01/14/2016

FY 2015

- Geo-Referenced, UAV-based 3D Surveying System for Precision Construction, Voxel, Inc., \$150,000, 06/08/2015 – 03/07/2016