

DOE Bioenergy Technologies Office (BETO) 2015 Project Peer Review

1.2.3.1

Biomass Feedstock Supply Modeling

March 26, 2015

Feedstock Supply and Logistics

PI: Erin Webb
Shahab Sokhansanj
Michael Hilliard
Craig Brandt
Anthony Turhollow

Oak Ridge National Laboratory

Goal Statement

Build and apply simulations of biomass supply chains

Towards reliably, affordably deliver a billion tons of on-spec biomass each year

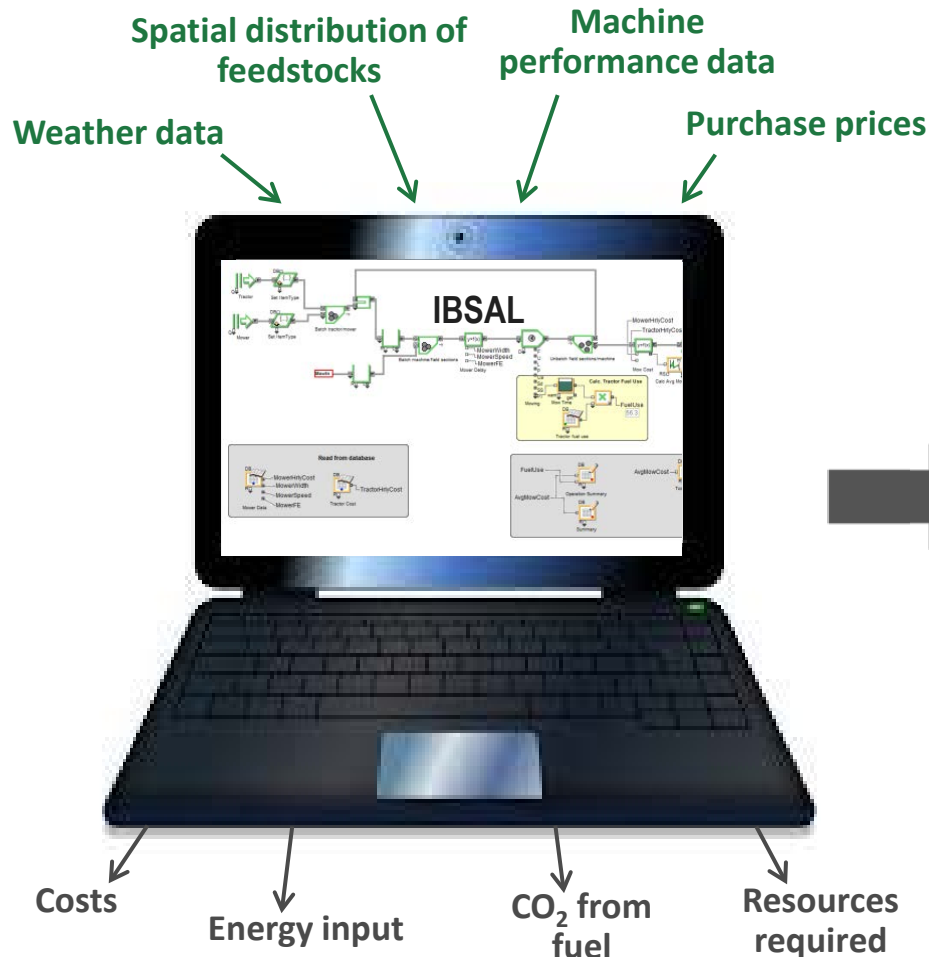

Perform experiments to test equipment designs and supply chain configurations

Characterize impacts of variability and uncertainty

Identify risk-reduction strategies

Optimize feedstock supply logistics

Quad Chart Overview

Timeline

- 2007
- 2017
- 60%

Barriers

- Ft-A Feedstock Availability and Cost
- Ft-L Biomass Handling and Transport
- Ft-M Overall Integration and Scale-Up

Budget

	Total Costs FY 10 –FY 12	FY 13 Costs	FY 14 Costs	Total Planned Funding (FY 15- Project End Date
DOE Funded	\$1,716,474	\$502,421	\$543,109	\$3,271,444
Project Cost Share (Comp.)*				

Partners

Collaborations

- Idaho National Laboratory
- FDCE
- Genera Energy, LLC
- Auburn University
- AGCO
- SUNY
- University of British Columbia
- University of Texas at San Antonio

1 - Project Overview

Working across entire terrestrial and algal feedstock supply chains

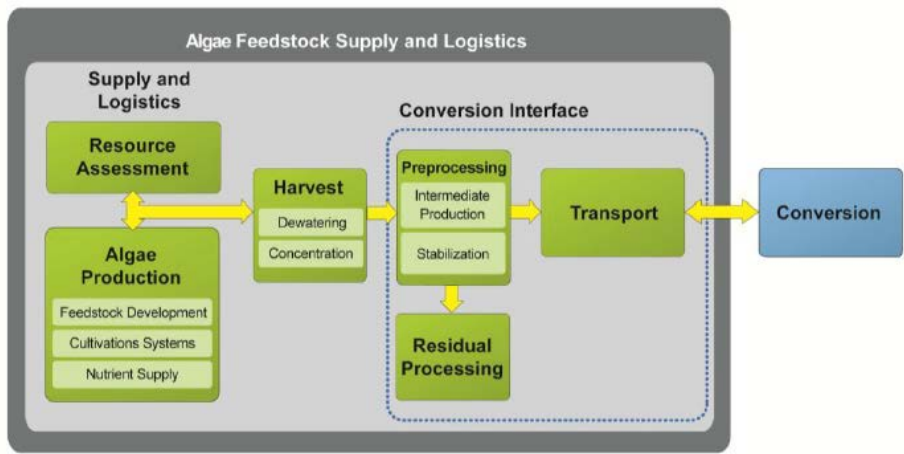
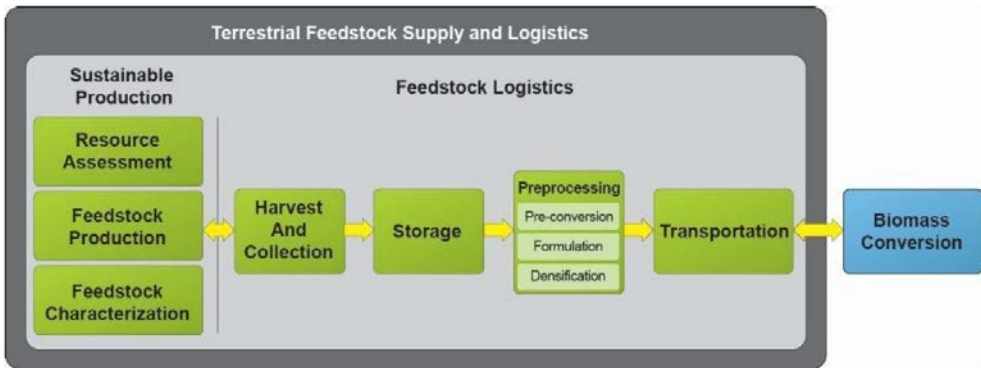

Modeling natural drying in the field and forest



Validation of logistics demonstration projects



*Accounting for overhead



*Modeling commercial-scale biomass storage systems



Systems approach to modeling biomass drying

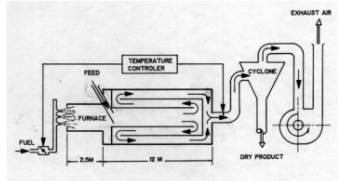

Spatial analysis of feedstock supply chains

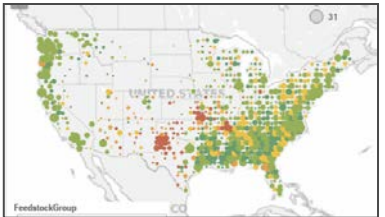

Simulation of algae oil and biomass supply chains

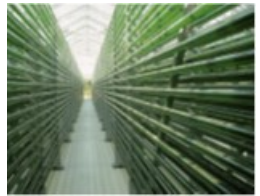

* Upcoming in FY15

2 – Approach (Technical)

Major Challenges

Modeling systems that do not yet exist at commercial scale

- Adapting strategies and algorithms applied for other industries
- Incorporate best data from industry and academic partners

Delivering feedstocks that meet moisture specs while reducing costs

- Comprehensive, systems-based approach to evaluating moisture management that includes natural and mechanical drying technologies

Optimizing supply chain design for local feedstock availability

- Developed a spatial analysis approach that accounts for local feedstock availability and infrastructure

Developing financially stable and affordable algae biofuel production systems

- Constructing simulation models that integrate algal biofuels with production of high-value coproducts
- Applying lessons learned in assembling terrestrial feedstock supply chains

Critical Success Factors

2 – Approach (Management)

Major Challenges

Critical Success Factors

Integrity of simulations

- Assemble a diverse research and advisory team to develop unbiased solutions for widespread benefit.

Impact of simulation results

- Consistent communication with industry partners to maintain awareness of challenges encountered in industry development

Simulation accuracy

- Adequately verifying and validating model performance

Acceptability of simulation results

- Clear communication and demonstration of simulations with stakeholders

3 – Technical Accomplishments/ Progress/Results

Validation of high-tonnage logistics demonstration projects using IBSAL

Corn stover

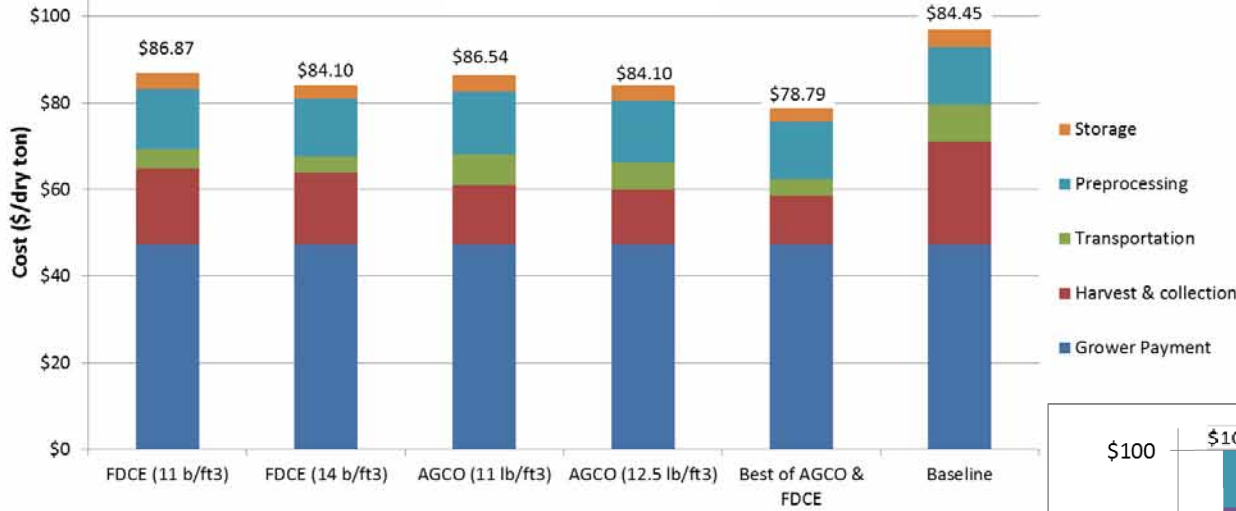

Cost improvements over baseline systems

- AGCO = \$13/dry ton
- FDCE = \$13/dry ton
- TennEra = \$4/dry ton
- SUNY = \$17/dry ton
- Auburn = \$17/dry ton

Woody biomass

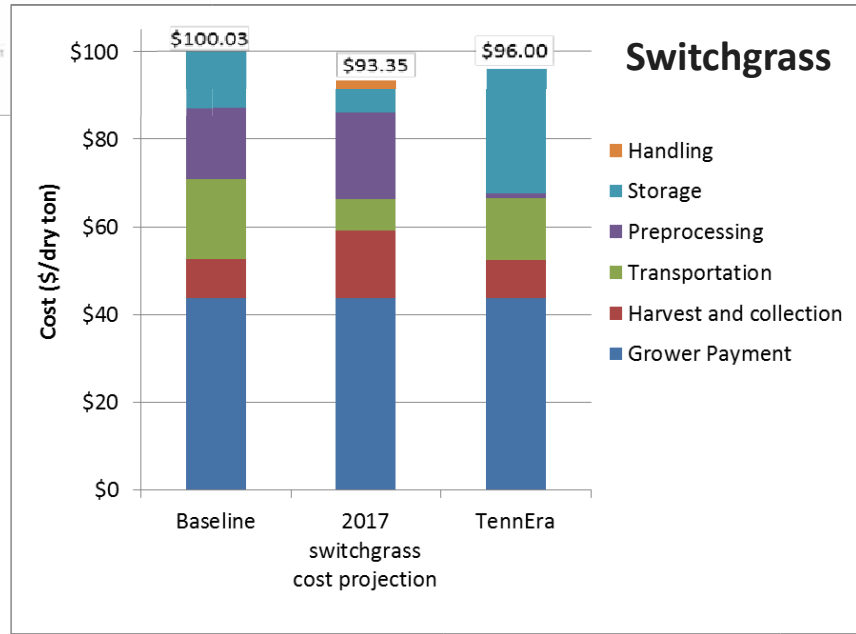
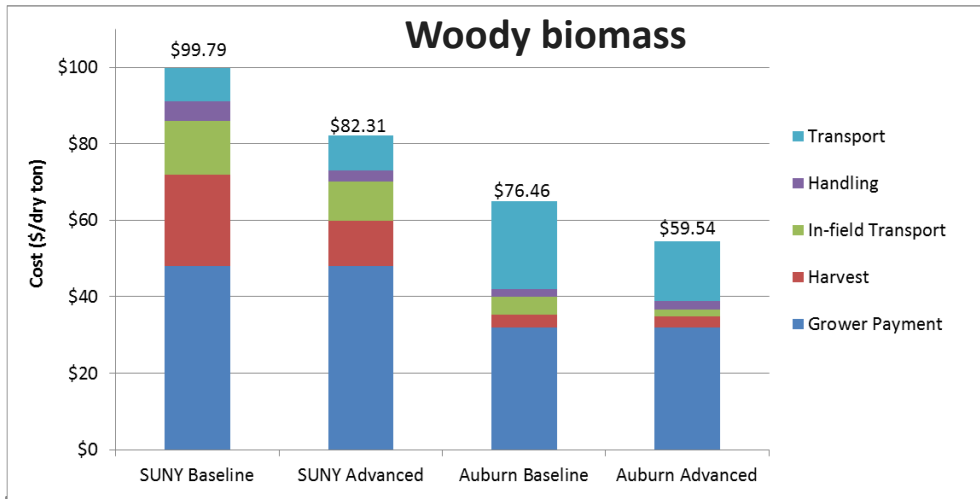

3 – Technical Accomplishments/ Progress/Results

Sensitivity analysis of high-tonnage logistics systems

- ±25% change in equipment price only caused a \$1/dry ton variation in feedstock cost
- ±25% change in diesel price – changed feedstock cost by \$2-\$5/dry ton (depends on transport distance)
- Throughput of harvest machinery significantly affects cost
 - **Field data critical for accurate harvest cost estimates!**

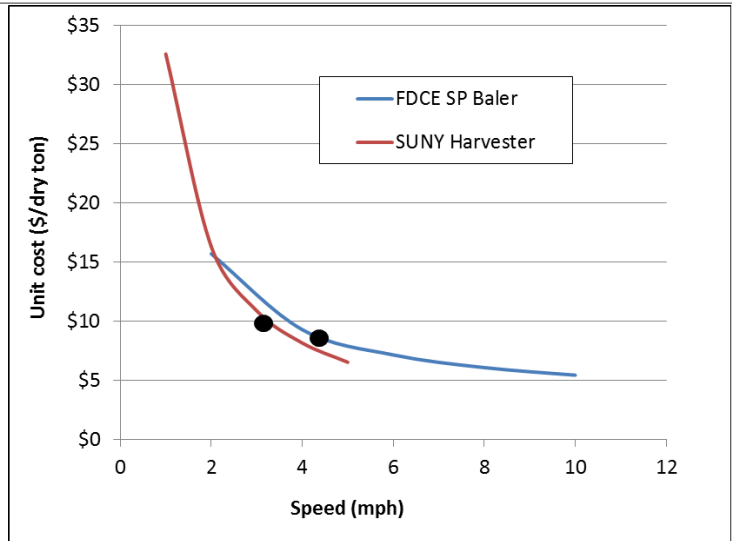
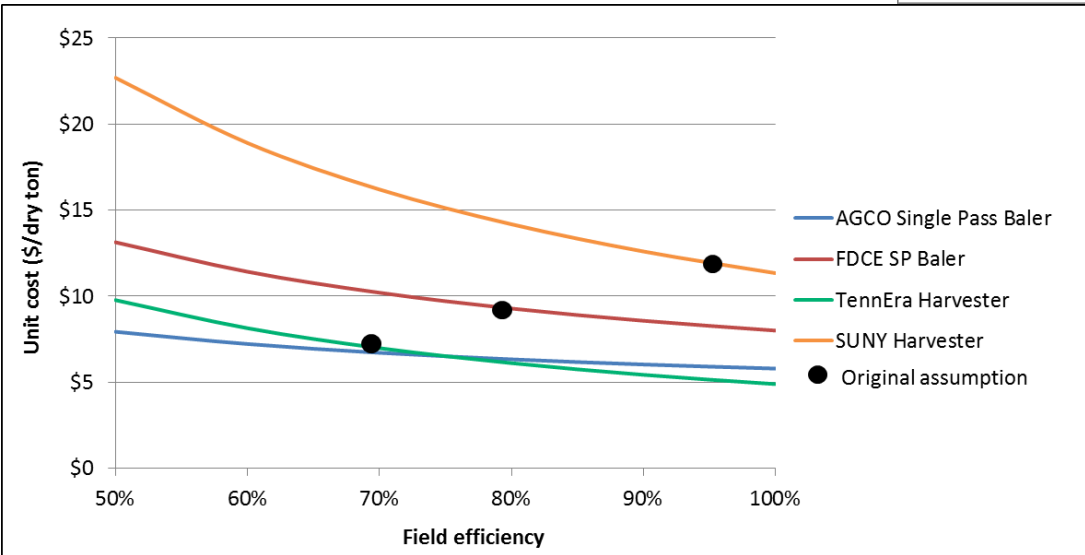
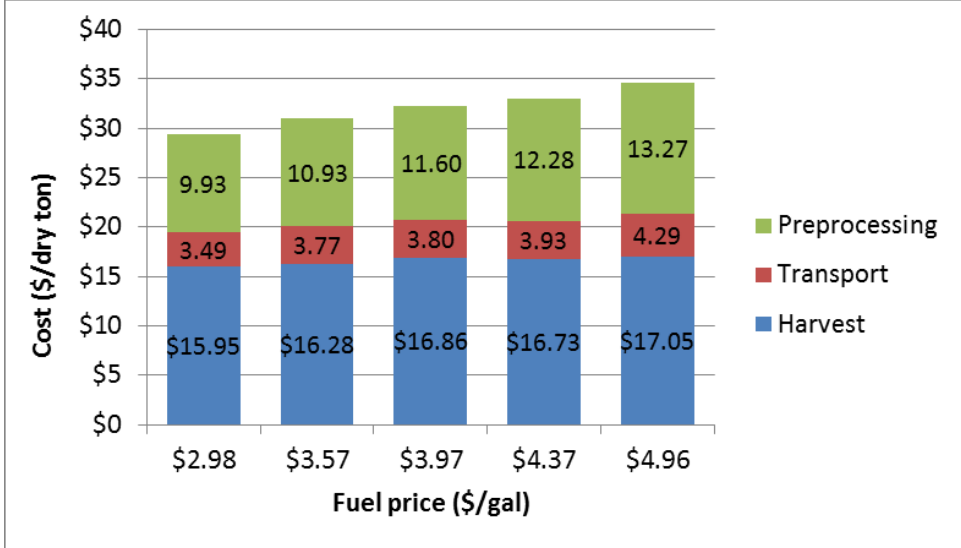

3 – Technical Accomplishments/ Progress/Results

INL PDU cost modeling

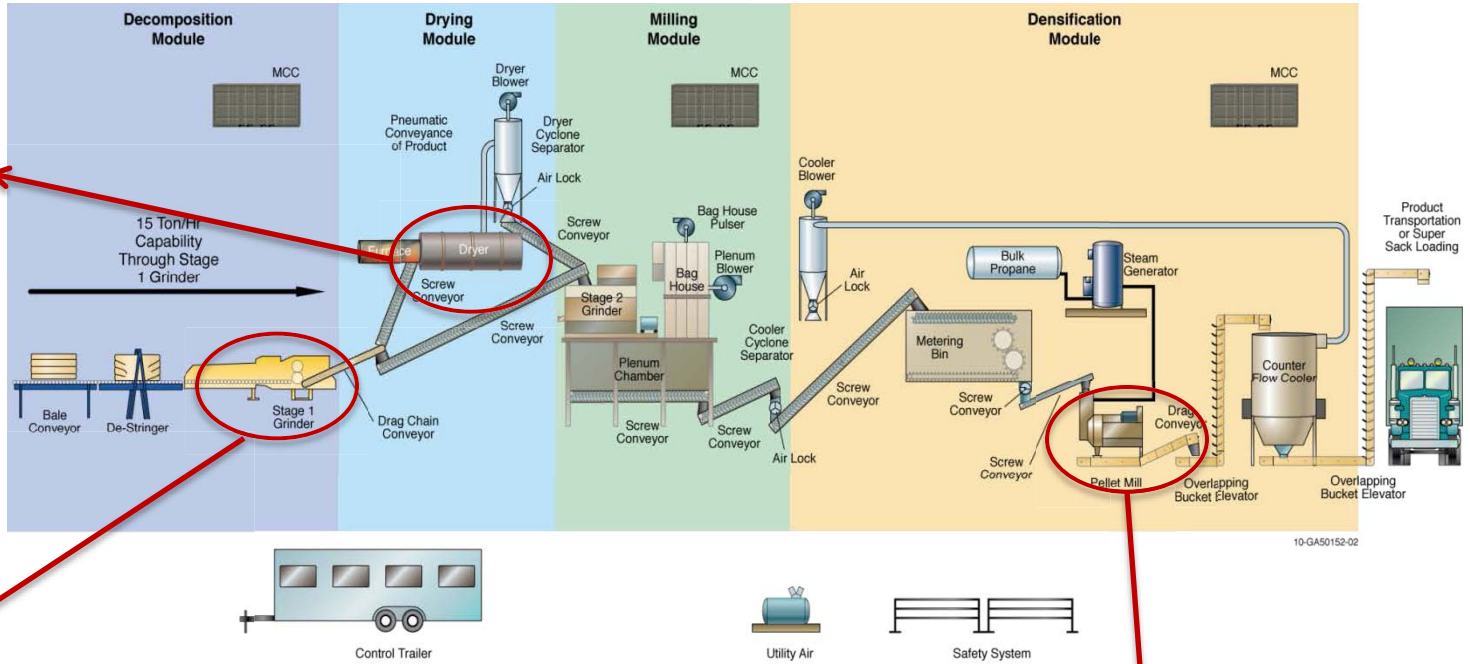
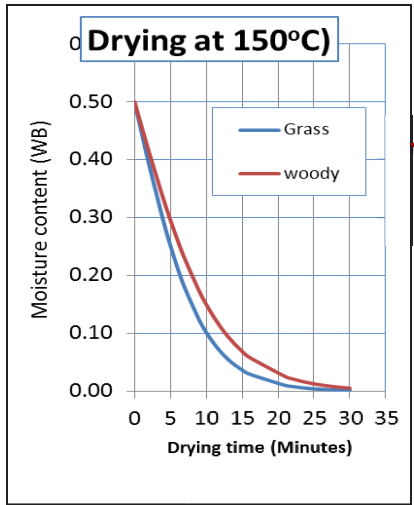

Calculating grinding energy

$$E = K_R \left(\frac{1}{L_p} - \frac{1}{L_f} \right)$$

	Shredder	Hammermill
Initial size (mm)	250	25
Final size (mm)	25	2
Moisture content (% wb)	0.25	0.25
Mass (kg)	10,000	10,000
Power input (kW)	50	50
Energy in put (kJ/kg)	5.54	70.84
Throughput (kg/hr)	32467.5	2540.9
Processing time (min)	29	365
Grinder cost (\$/ton)	\$6.41	\$20.78

Calculating force for pelletization

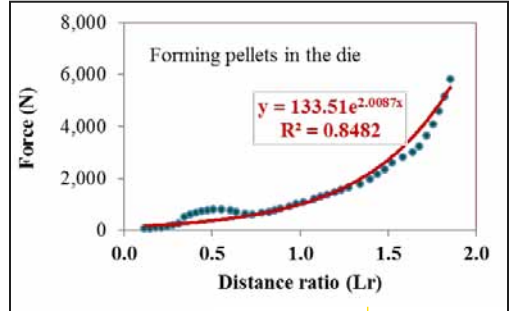

3 – Technical Accomplishments/ Progress/Results



Simulation of logging residue collection and transportation

Whole-tree harvest

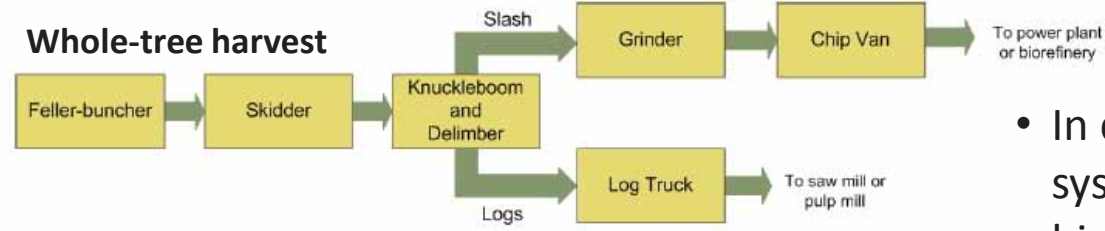

Cut-to-length harvest system

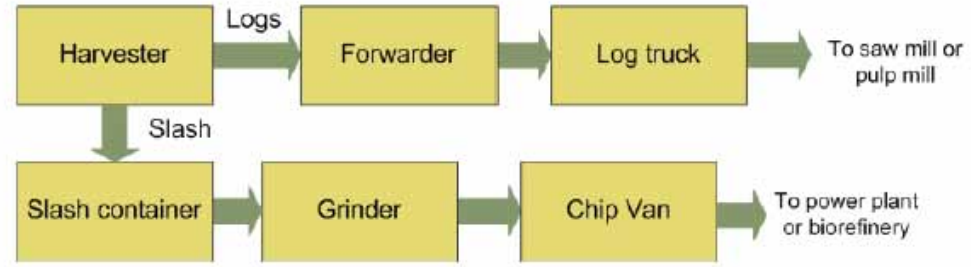

- In conventional whole-tree harvest systems, moisture and ash contents are higher than desired
- Developing Cost-of-Quality model to consider tradeoffs between investing in moisture and ash reduction strategies and using as a low-cost blending feedstock

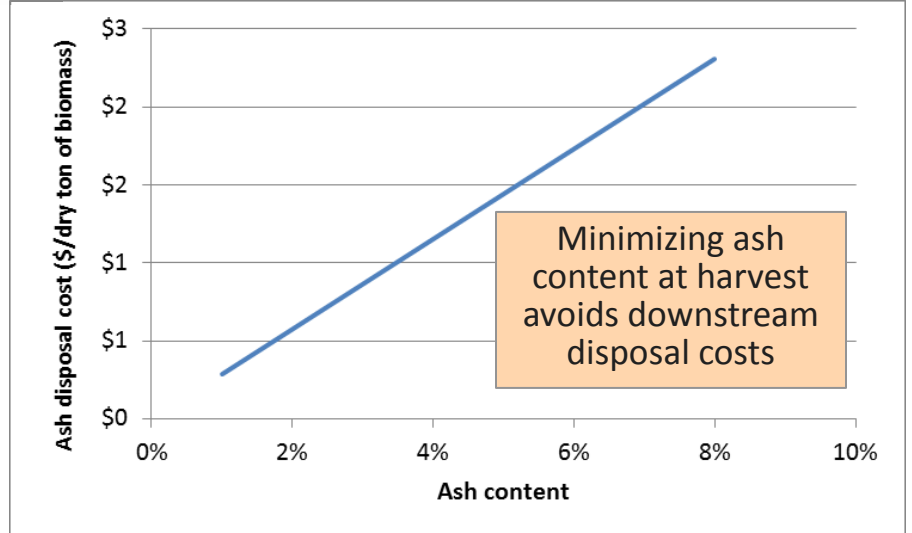
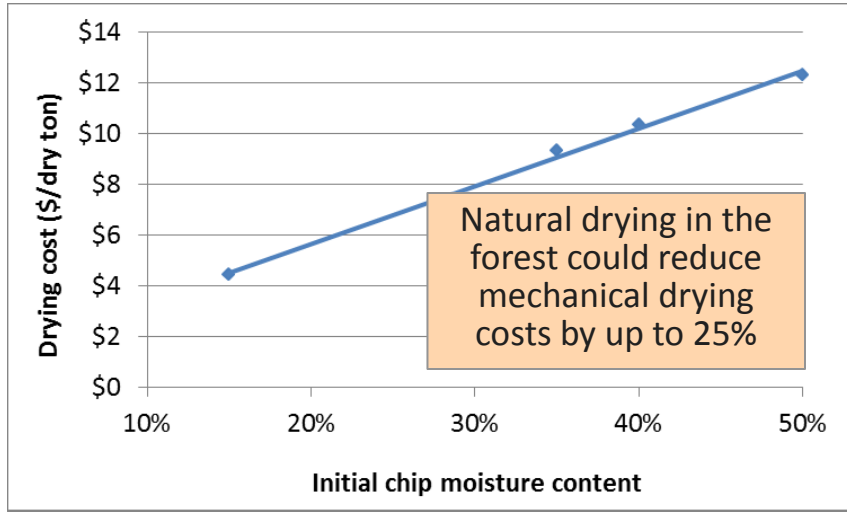

3 – Technical Accomplishments/ Progress/Results

Systems approach to simulating industrial drying

- Drying can be the most expensive and energy-intensive operation in the feedstock supply chain
- Energy required is determined by condition of incoming biomass (e.g. moisture content, particle size) and, in many cases, ambient conditions around dryer
- Many drying models do not fully account for upstream operations (e.g., field drying or grinding) or ambient conditions

Many biomass dryers are outdoors and heat required varies with ambient conditions

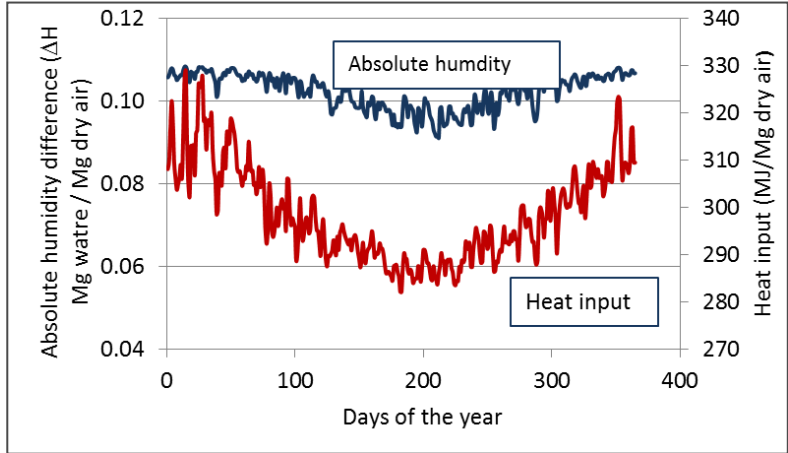

Drying time increases with particle size

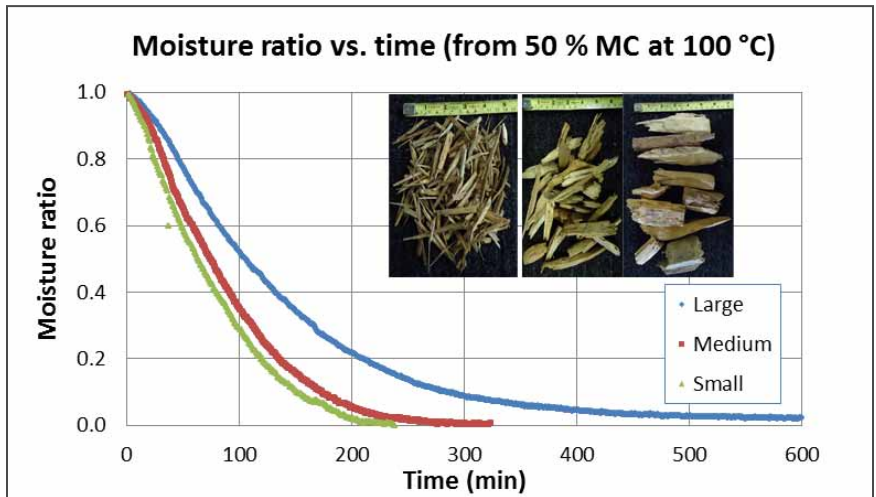

Energy, and thus cost, for drying increases dramatically with incoming moisture content

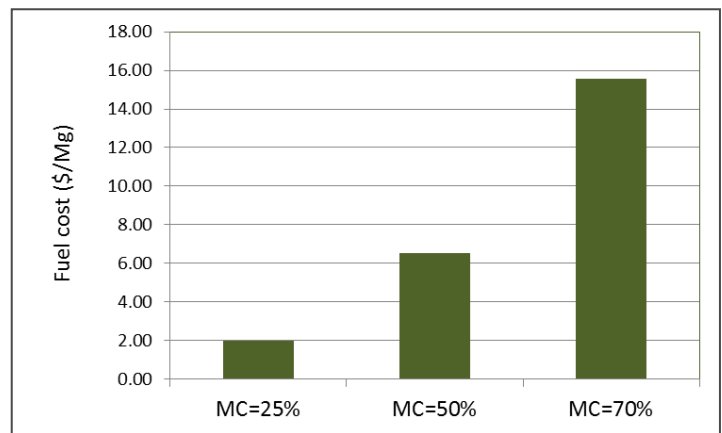

3 – Technical Accomplishments/ Progress/Results

Spatial analysis of feedstock supply chains

- Successfully linked transportation and siting model with advanced visualization techniques to spatially explore feedstock supply options
- Supply Characterization Model (SCM) sites optimal facility locations (on a 50-mile grid) to minimize feedstock costs
- Utilizing interactive visualizations (developed in Tableau) of SCM outputs to determine where advanced feedstock supply options are needed to achieve cost and quantity targets.

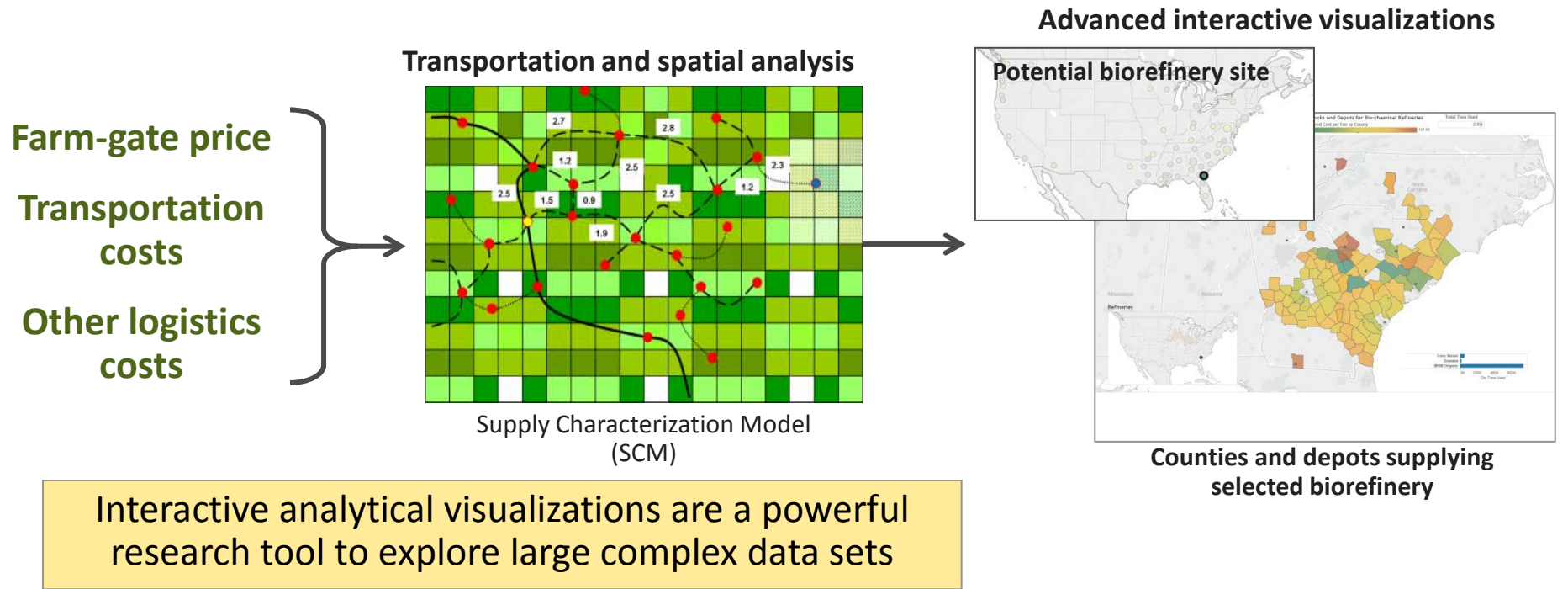

3 – Technical Accomplishments/ Progress/Results

Spatial analysis of feedstock supply chains

- Developed method to compare feedstock costs as delivered to the reactor throat for various supply chain scenarios.
- Compared conventional (current technology) with an advanced system (high-moisture pelleting)

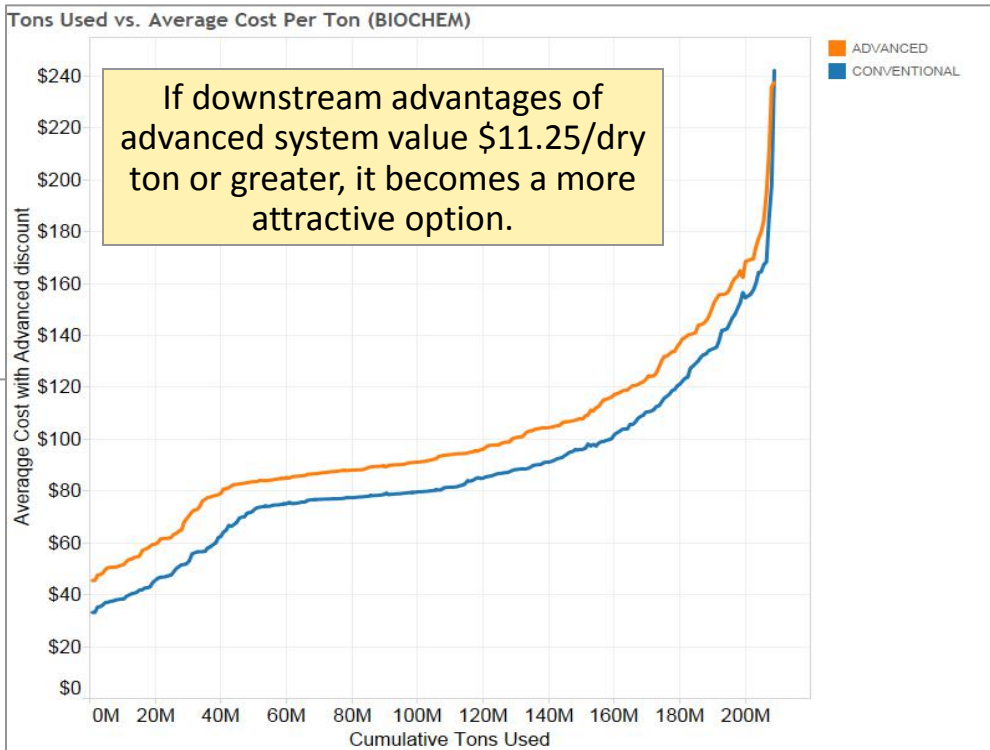
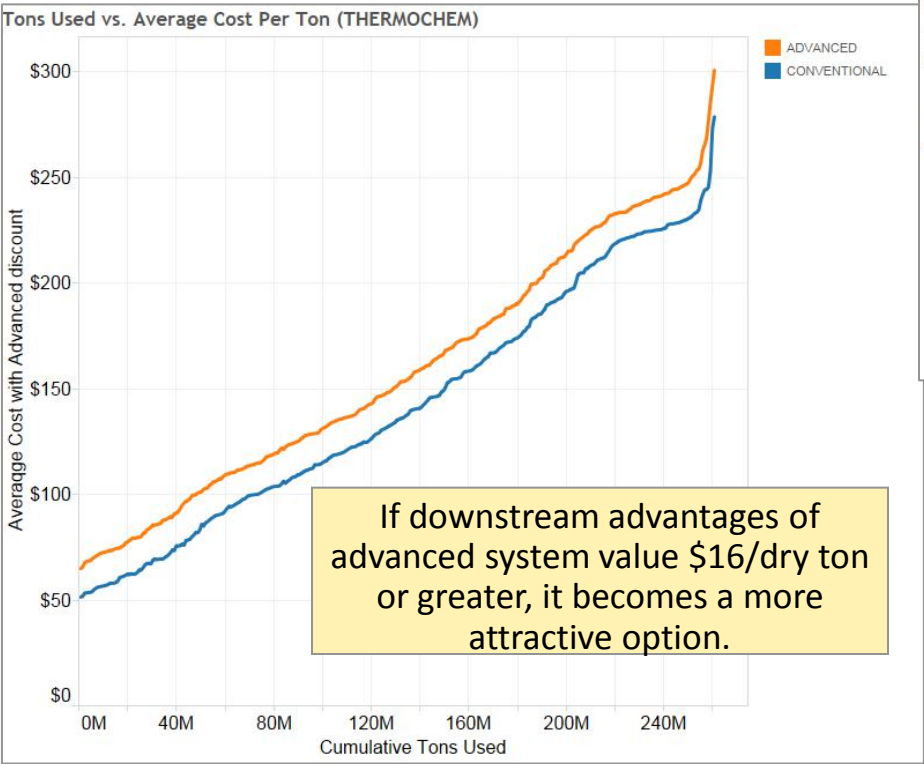

- Estimated a “discount” value for the advanced system to account for cost reductions from improved handling, more efficient conversion, etc.
- Applying this methodology to develop delivered supply curves for resource assessment projections

3 – Technical Accomplishments/ Progress/Results

Advanced Feedstock Supply System Workshop

Participants from the biorefinery, feedstock sourcing and supply, equipment, and data management industries along with academia were invited to provide input on:

What are the barriers and solutions to supplying one billion tons of biomass by 2030?



3 – Technical Accomplishments/ Progress/Results

Advanced Feedstock Supply System Workshop Results

- Current large-scale biomass suppliers were concerned about availability of biomass at the farm
 - Need adequate incentives for producers
 - Mixed messages about sustainability inhibit producer involvement
- General consensus that the depot concept would overcome barriers in supplying one billion-tons annually, *but concerned about how to get there from current systems*
- Multiple markets for depots necessary to stand up feedstock industry
- Strategies for dealing with high-moisture biomass would be “game changer”



To supply a billion-tons annually, must reduce risk across the supply chain

Producers and land owners need stronger markets and clearer guidance on sustainability

Harvesters, brokers and biorefineries need advanced quality management strategies and higher efficiency/throughput equipment

3 – Technical Accomplishments/ Progress/Results

Developed preliminary IBSAL-algae model

Utilizing unit operations models for algae processing developed by other labs and lessons learned in storage, transport, and handling of terrestrial feedstocks

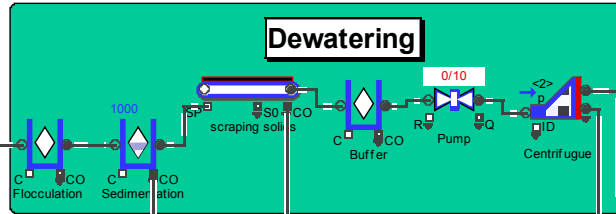
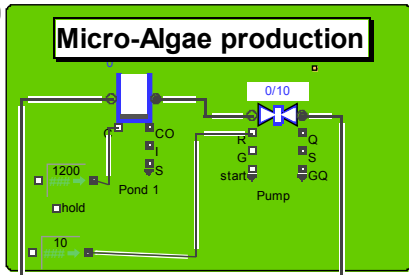

Decision point on dry or wet pathway

Similar to IBSAL Terrestrial

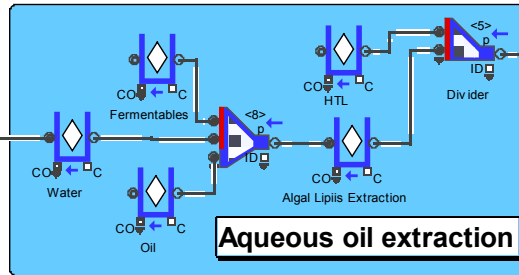
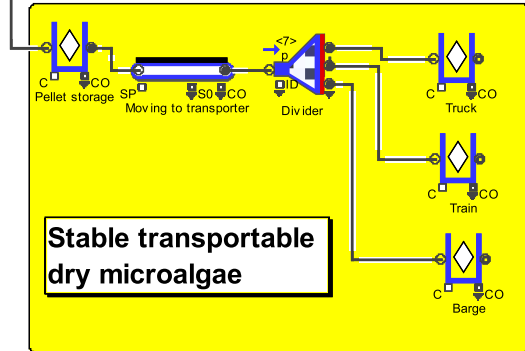
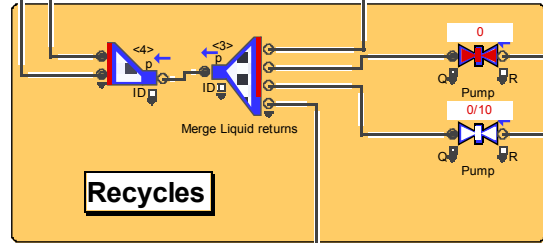
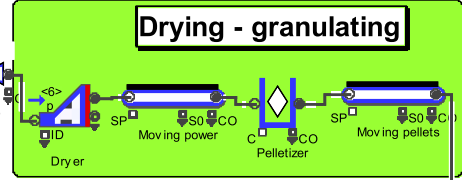

Production



Dewatering to paste



Paste to powder



Stable pellets

3 – Technical Accomplishments/ Progress/Results

Feasibility assessment of dry algae feedstock

- Drying and pelletizing algae significantly increases efficiency of transportation and handling and reduces costs.
- Preliminary feasibility assessment:
 - Assumed value of delivered algae pellets = \$162.40/dry ton
 - The cost of producing pelleted microalgae to harvest stage is back calculated to \$26.17/ton
 - BETO's MYPP (2014) projections estimates algae production cost at \$32.82/dry ton. Reducing drying costs by \$6.65/ ton will make drying and pelletization economical

Operations	(\$/ton)	Source and comments
Transport and handling	\$23.25	DOE (2013), 2017 projections
Storage	\$7.53	Man et al. (2006) Adjusted to \$2014
Pelletization	\$12.81	Mani et al. (2004) Adjusted to \$2014
Drying	\$35.65	Mani et al. (2004) Adjusted to \$2014
Harvest to 200 g/L	\$57.60	Grima et al. (2003) Adjusted to \$2014

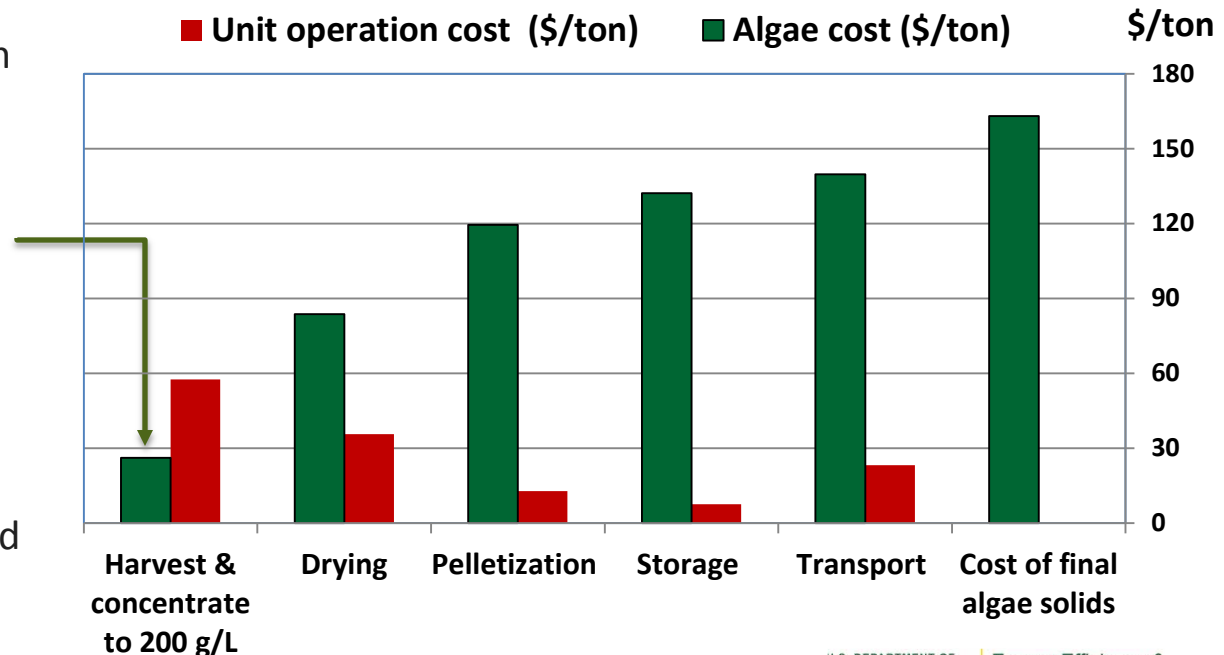

3 – Technical Accomplishments/ Progress/Results

Linking algae resource assessment, production, and logistics

- Algae produced in polyculture systems have larger variations in material properties that impact system performance along the entire supply chain
- *Collocating algae processing operations with waste heat sources has potential to significantly reduce drying costs*

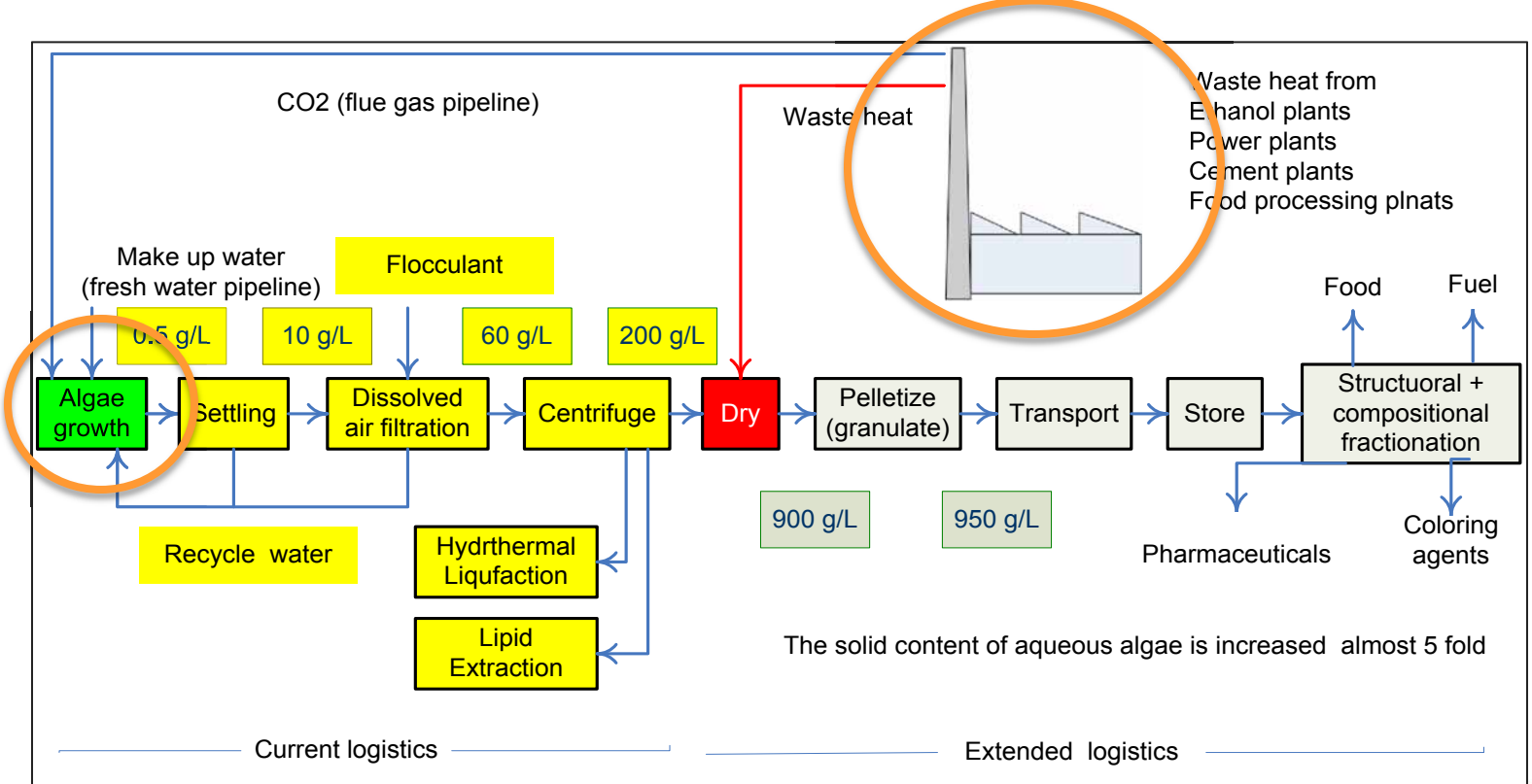

4 – Relevance

- **Evaluate new technologies and systems**
 - IBSAL simulations of DOE-funded logistics demonstration projects showed that these systems provide cost improvements over baseline systems at commercial scale
 - Reductions of \$13-17/dry ton make it possible to achieve \$80/dry ton delivered cost target
- **Characterize impacts of uncertainty and variability**
 - Can perform “experiments” with supply chain configurations/technologies that would be cost prohibitive to test at commercial scale
- **Spatial analysis of supply chains based on resource availability**
 - New spatial analysis approach makes it possible to determine where systems work and to refine costs based on local and regional conditions.
 - Approach being used to develop reactor throat supply curves for BT16

5 – Future Work

- **Spatial analysis of biomass supply chains**
 - Consider impacts of reduced biomass availability due to drought or other system shocks
 - Leverage tools and methodology developed in this project to create reactor-throat supply curves for 2016 Billion-Ton Report Update
- **Supply chain business costs**
 - In response to criticism that simulated costs are lower than can be achieved in practice, we are preparing for a case study analysis to estimate costs of overhead, equipment transport, etc.
- **Moisture management**
 - Developing maps of moisture content at harvest and a spatial analysis to determine where field drying of residues is feasible
 - Linking models of moisture changes across the supply chain to build more comprehensive simulations that better account for moisture impacts
- **Build IBSAL-algae simulation equations and validate**
 - Analogous to terrestrial model to estimate costs, energy input, and carbon accounting from the growth of the algae to harvest and post harvest systems (including co-location for CO₂ and heat recovery)

Summary

- **Leveraging relationships with industry, labs, and academia to create accurate, impactful simulations of terrestrial and algal feedstock supply chains**
 - Quantifying cost improvements of harvest, collection, storage, and transportation industry and academia-led demonstration projects
 - Developing/refining algorithms for advanced biomass processing
 - Evaluating logging residue collection systems
 - Modeling “cost-of-quality”
 - Developing comprehensive, systems-based moisture management strategies
 - Resource-based spatial optimization of feedstock supply chains
 - Algal feedstock pond-to-reactor supply chain analysis
- **Linking IBSAL simulation results with a transportation model and advanced visualization tool to develop interactive data visualizations for experimenting with biomass supply chain scenarios**
 - Developing reactor-throat supply curves for 2016 update to Billion-Ton Report

Responses to Previous Reviewers' Comments

2013 Reviewer Comment	Response
<p><i>...I can assume work with this model will continue. However, the future of IBSAL was not sufficiently discussed.</i></p>	<p>Development and refinement of IBSAL continues with the addition of new feed stocks (e.g., algae), incorporation of new capabilities (e.g., drying), and algorithms to better track quality along the supply chain (e.g., moisture). IBSAL will be an integral part of our new spatial analysis capability for biomass supply chains.</p>
<p><i>Broader communication with other non-funded companies and universities will be important to leverage this federal investment for public benefit. BETO should be more actively developing industry advisory groups and other feedback mechanisms to drive analysis toward critical industry needs.</i></p>	<p>Agreed. This was a major motivation behind the Advanced Feedstock Supply Systems workshop which included companies and universities that have received federal funds and some that have not.</p>

Publications, Patents, Presentations, Awards, & Commercialization

- Webb, E., M. Hilliard, C. Brandt, S. Sokhansanj, L. Eaton, and M. Martinez Gonzalez. 2014. *Spatial Analysis of Depots for Advanced Biomass Processing*. ORNL/TM-2014/503.
- Sokhansanj, S. and E. Webb. 2014. *Investigating Options to Reduce the Logistical Cost of Microalgae Feedstock for Biofuels and Bioproducts*. ORNL/TM-2014/463.
- Sokhansanj, S., A. Turhollow, and E. Webb. 2014. *Simulation of the DOE High-Tonnage Logistics Projects: Auburn University*. ORNL/TM-2014/505.
- Davison, B. H., C. C. Brandt, A. M. Guss, U. C. Kalluri, A. V. Palumbo, R. L. Stouder, and E. G. Webb. 2014. The impact of biotechnological advances on the future of U. S. Bioenergy. *Biofuels, Bioproducts, and Biorefining* (accepted).
- Sokhansanj, S., E. G. Webb, and A. T. Turhollow. 2014. Evaluating industrial drying of cellulosic feedstock for bioenergy: a systems approach. *Biofuels, Bioproducts, and Biorefining* (in revision).
- Langholtz, M., E. Webb, B. L. Preston, A. Turhollow, N. Breuer, L. Eaton, A. King, S. Sokhansanj, S. S. Nair, and M. E. Downing. 2014. Advancing Climate Risk Management for the U.S. Cellulosic Biofuels Supply Chain. *Climate Risk Management* 3: 96-115.
- Sokhansanj, S., E. G. Webb, and A. Turhollow. 2014. *Evaluating industrial drying of cellulosic feedstocks for bioenergy – A systems approach*. ORNL/TM – 2014/165.
- Davison, B. H., C. C. Brandt, A. M. Guss, U. C. Kalluri, A. V. Palumbo, and E. G. Webb with R. Stouder. 2014. *Report on Impact of Biotechnology on US Bioenergy*.
- Webb, E. G. and S. Sokhansanj. 2014. *Sensitivity Analysis of Biomass High-Tonnage Logistics Projects*. Oak Ridge National Laboratory. ORNL/TM-2013/568.
- Webb, E. G., S. Sokhansanj, and A. Turhollow. 2013. *Simulation of the DOE High-Tonnage Biomass Logistics Demonstration Projects: AGCO Corporation*. Oak Ridge National Laboratory. ORNL/TM-2013/323.
- Webb, E. G., S. Sokhansanj, and A. Turhollow. 2013. *Simulation of the DOE High-Tonnage Biomass Logistics Demonstration Projects: FDC Enterprises*. Oak Ridge National Laboratory. ORNL/TM-2013/338.
- Webb, E. G., S. Sokhansanj, and A. Turhollow. 2013. *Simulation of the DOE High-Tonnage Biomass Logistics Demonstration Projects: TennEra LLC*. Oak Ridge National Laboratory. ORNL/TM-2013/375.
- Webb, E. G., S. Sokhansanj, and A. Turhollow. 2013. *Simulation of the DOE High-Tonnage Biomass Logistics Demonstration Projects: SUNY*. Oak Ridge National Laboratory. ORNL/TM-2013/376.

Additional Slides

Preliminary sensitivity analysis of algae logistics operations

Power input to algae centrifuge vs. change in operating conditions

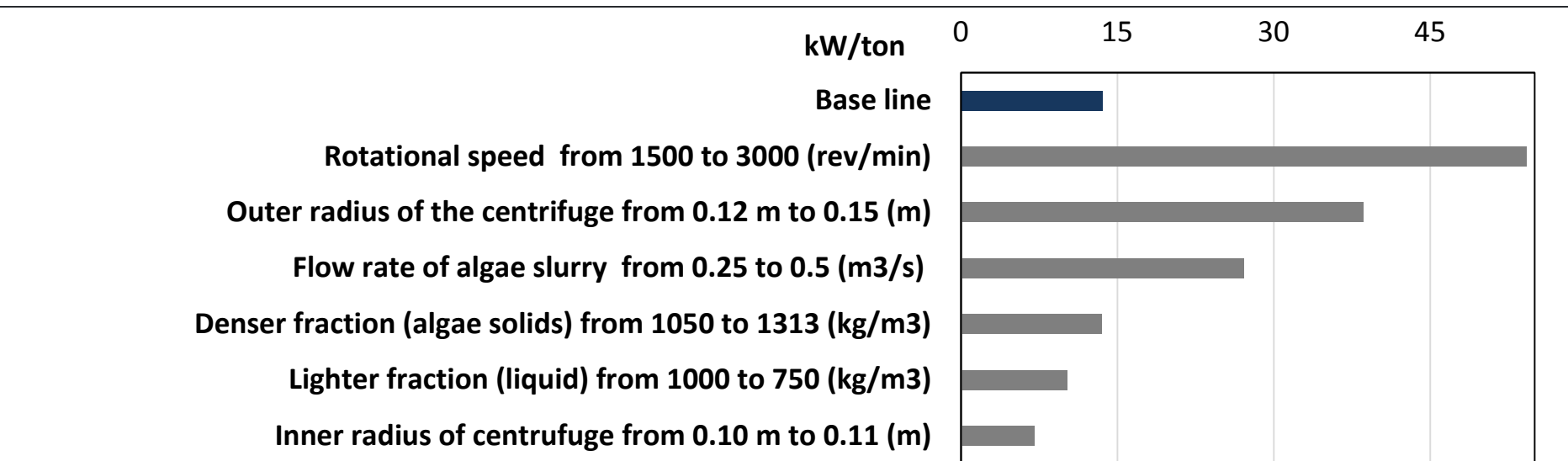

Sokhansanj, Shahab, Erin Webb. 2014. Investigating options to reduce the logistical cost of microalgae feedstock for biofuels and bioproducts. ORNL/TM-2014/463 Oak Ridge National Laboratory, Oak Ridge TN 37831.

Additional Slides

- IBSAL Marches in time to establish pond's operating parameters to minimize the logistical costs associated with handling solid concentrations and flow rates

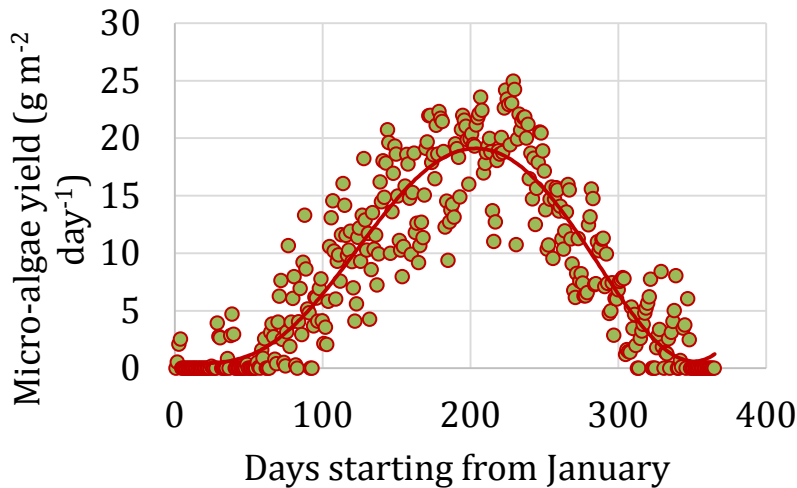

Daily Micro-algae yield using kinetic equations for algae growth model and the TMY (Typical Meteorological Year) weather data for Knoxville TN.

Basic assumptions on pelletized micro-algae production dry mass, water and land requirements

Microalgae production (mass) in a year (tonne)	250
Number of working days (days)	150
Daily production rate (kg d⁻¹)	1,667
Microalgae average concentration (g L⁻¹)	0.5
Number of ponds	198
Total pond area required (ha)	33
Outlet flow rate from each pond (m³ h⁻¹)	11
Outlet flowrate from all ponds (m³ h⁻¹)	139

Sokhansanj, Shahab, Erin Webb. 2014. Investigating options to reduce the logistical cost of microalgae feedstock for biofuels and bioproducts. ORNL/TM-2014/463 Oak Ridge National Laboratory, Oak Ridge TN 37831. 20 pages. 32 pages.

Additional Slides

The following table offers an IBSAL method of cost analysis that would contribute to a better understanding of microalgae harvest economics and identify opportunities to reduce costs. We assume that the final microalgae product is available in pellet form at a density of about 750 kg and a moisture content of 6%. The value of dry microalgae in this form depends on four products: biofuel, animal feed, fertilizer, and pharmaceutical/food additives. The following Table 1 allocates the potential mass fraction of microalgae for each of the applications based on the composition of the microalgae; i.e., 50% lipids, 40% proteins; 8% minerals; 2% vitamins and coloring agents. The potential market price for each fraction is given in dollars per ton. The combination of mass fractions and the expected value brings the value of the dry microalgae pellets to \$162.40 per ton. The data from this table is used to do reverse cost calculations in

Percent of the dried microalgae used for four applications and the assumed unit cost for each fraction. In this table cost is equivalent to the price that each fraction can fetch

Uses of algae biomass	Cost (\$/ton)	Fraction (%)	Cost (\$)
Biomass feedstock for biofuel	\$80	50	\$40.00
Animal feed	\$250	40	\$100.00
Fertilizer	\$30	8	\$2.40
Pharmaceutical/food additives	\$1,000	2	\$20.00
Sum		100	\$162.40