

Waste Heat-to-Power in Small Scale Industry Using Scroll Expander for Organic Rankine Bottoming Cycle

Development of an Efficient, Cost-Effective System to Recover Medium-Grade Industrial Waste Heat.

There is a significant opportunity to recover waste heat that is exhausted in various manufacturing industries, including food processing. A large portion of unrecovered industrial waste heat is considered to be low temperature, which has less recovery value than high-temperature waste heat. Despite the lower recovery value, there is an opportunity for large energy savings if cost-effective technologies can be developed to recover and reuse low-temperature waste heat.

Systems that utilize the Organic Rankine cycle (ORC) can convert medium-grade waste heat at lower temperatures into electric power. Typically, barriers to the development and deployment of small-scale waste heat recovery systems in manufacturing include payback period, lack of engineering resources, and impact on production and product quality. A proprietary scroll expander technology, developed by TIAX LLC, will help reduce the size, cost, and complexity of the waste heat recovery system that uses an ORC while also increasing efficiency compared to conventional bottoming cycle expander concepts. Medium-grade waste heat streams could be utilized effectively by an efficient, mechanically sound scroll expander that operates at an optimal power range. Scroll expander technology has already been successfully demonstrated with carbon dioxide expanders.

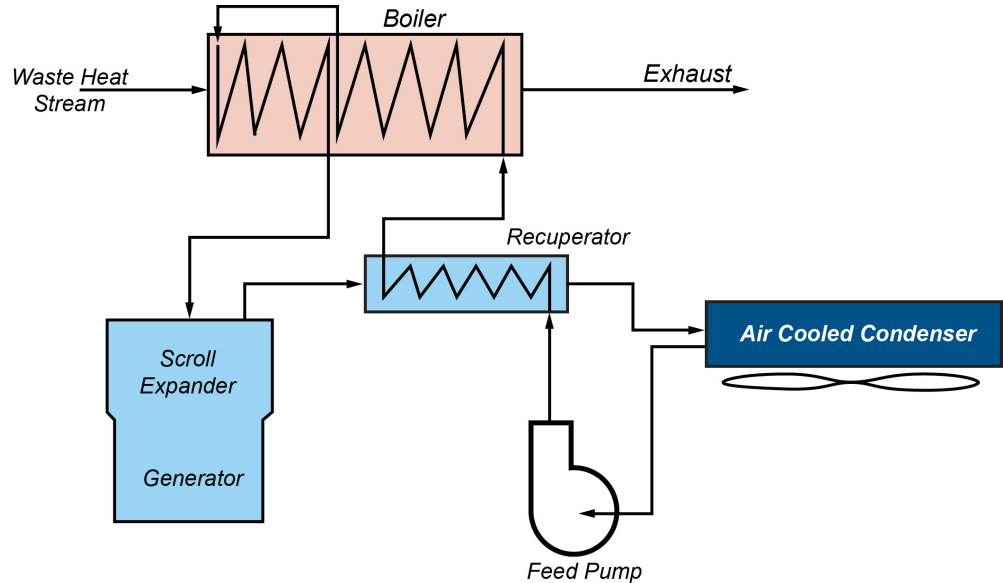

Bottoming cycle schematic with the scroll expander technology. *Graphic credit TIAX.*

In the basic operation of the scroll expander-based ORC, working fluid is pumped through a recuperator and vaporized in a boiler, where it absorbs the waste heat. This vapor then leaves the boiler and enters the scroll expander, where the motion is converted to shaft power and drives an electric generator. After the working fluid is exhausted from the scroll expander, it again passes through the recuperator to be cooled, then to the condenser before being pumped back through the recuperator to the boiler. The design flexibility of the scroll expander allows for it to match the temperature availability of a specific waste heat stream. The scroll expander can also be scaled to a specific capacity and can accommodate a variety of organic and inorganic working fluids. In addition, the volume ratio can be varied to match the pressure ratio.

Benefits for Our Industry and Our Nation

The scroll expander-based ORC system could generate large energy benefits by enabling waste heat recovery from medium-grade waste heat streams that occur in a variety of industries. Applying the scroll expander technology will

improve the performance and reduce the cost of ORC in smaller-scale waste heat recovery applications. Even in batch operations (e.g., those found in food processing), which have more limited potential savings, between 5% and 30% of input energy could potentially be recovered. Waste heat recovery will also achieve environmental benefits. For example, the technology could reduce the current carbon footprint of coffee roasting by up to 50% through the production of electricity and hot water.

Applications in Our Nation's Industry

While the technology will be initially applied in coffee roasting, it could also be applied in other food processing applications such as bakery operations, breweries, pet food production, dry roasting of nuts, and cocoa/chocolate processing, along with other industries such as textiles, plastics, fabricated metals, and foundries. Specifically, it will be compatible with industrial processes that exhaust moderate-quality waste heat between 400°F and 800°F.

Project Description

The project objective is to develop the scroll expander for ORC systems to be used in industrial and commercial medium-grade waste heat recovery applications, and to validate and quantify the benefits of the prototype system compared to other waste heat recovery technologies. It is expected that the scroll expander will achieve an overall efficiency of 75% to 80%.

Barriers

- Limiting internal leakage losses in the expander and feed pump which would result in excess flow for the expander and an insufficient pressure rise in the pump.
- Limiting friction losses from the initial bearing and pressure balance configuration, which would reduce efficiency.
- Degradation of lubrication and/or working fluid in the boiler.

Pathways

The ORC design will be refined and the performance will be analyzed in order to ensure that it can be implemented as an efficient, cost-effective, and adaptable package. After the ORC design is completed, a more detailed design of the scroll expander will be developed. Following bench test planning and design, the waste heat recovery system will be assembled and tested in a laboratory environment. A waste-heat-to-power system featuring the scroll expander technology will then be installed in a coffee roasting plant and will undergo field testing.

Milestones

This three-year project began in 2013.

- Complete overall design of the waste heat recovery system, including the scroll expander and major ORC components, and analyze/model system performance (Completed).
- Design the bench test system, identify and purchase specific parts, fabricate components, and assemble the bench test system (Completed).
- Perform laboratory testing of the bench test system over a range of conditions and speeds, including initial operation of the scroll expander and with efficiencies above 70% (2015).
- Complete design of the field test system based on technical data specific to the roasting system; fabricate and assemble the field test system (2015).
- Install and operate the field test system at design capacity for nine months; collect data to determine actual performance (2016).

Commercialization

Field testing the prototype waste-heat-to-power system with Green Mountain will help facilitate and expedite its development as well as validate and benchmark its performance outside of laboratory conditions. The team also intends to engage Green Mountain's equipment suppliers during testing to help overcome resistance to waste heat recovery systems and accelerate commercialization and market deployment. At the conclusion of the project, TIAX LLC plans on partnering with commercial companies to produce, sell, and support waste heat recovery systems based on the scroll expander technology.

Project Partners

TIAX LLC
Lexington, MA
Principal Investigator: John Dieckmann
Email: dieckmann.j@tiaxllc.com

Green Mountain Coffee Roasters
Waterbury, VT

For additional information, please contact

Bob Gemmer
Technology Manager
U.S. Department of Energy
Advanced Manufacturing Office
Phone: (202) 586-5885
Email: Bob.Gemmer@ee.doe.gov ■