

The Fuel Cell Mobile Light Project -- A DOE Market Transformation Activity--

Lennie Klebanoff

Sandia National Laboratories

Chris Radley

Altery Systems

Torsten Erbel

Multiquip Inc.

DOE Fuel Cell Technologies Webinar

November 13, 2012



“Exceptional Service in the National Interest”

Boeing Interested in Bringing Fuel Cell Technology to Ground Support Equipment (GSE)

3/1/2008:

“We (Boeing) would like Sandia to lead an effort with us to bring hydrogen fuel cell technology to airport ground support equipment” -- **George Roe, Manager Boeing Research and Technology**

George suggested we consider a H₂ fuel cell version of a mobile aircraft maintenance light:

Basic Idea:

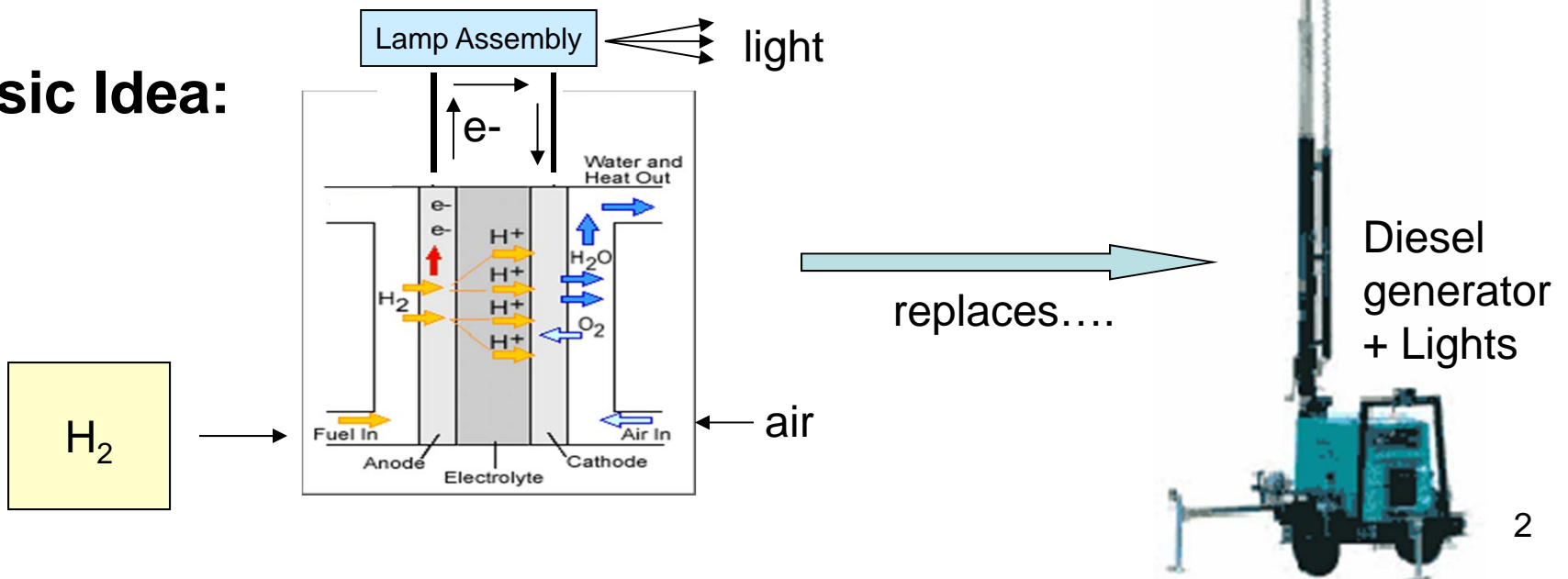

We Created a Strong Development Team (The Circle of Love)



*Other participants:
NASA KSC
Paramount Pictures*

New Technology Experts + Manufacturing Partners + End Users

Special thanks to Tom Damberger (Golden State Energy) for helping me put the team together!

Combining Fuel Cell Power with Plasma Lighting

PEM Fuel Cell

Altery FPS-5 (5kW)

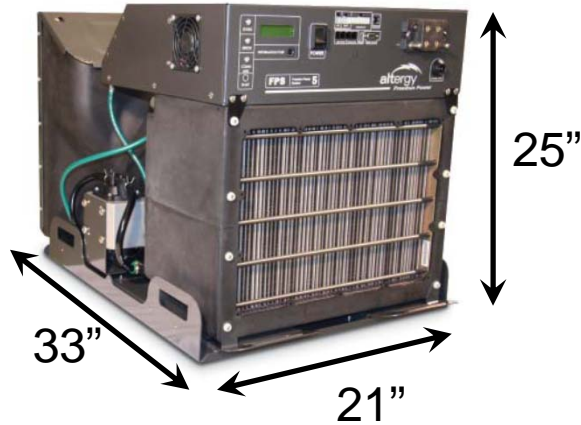

Combine two sources of increased energy efficiency: fuel cells and advanced lighting

-- Already in use for cell-tower backup power

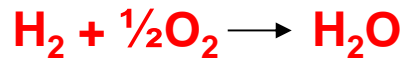

Plasma Lighting



Luxim plasma light bulb

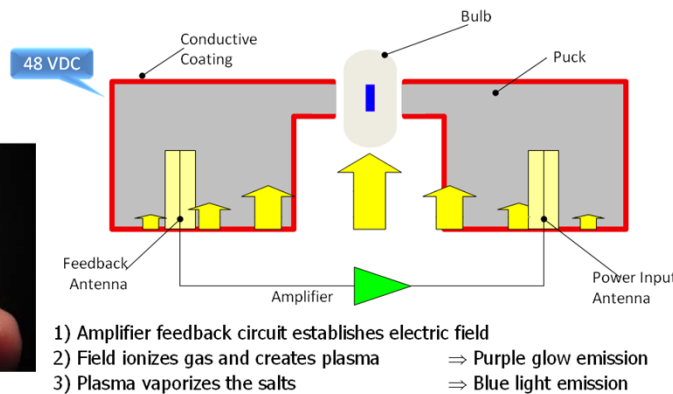

- High efficiency
- 50,000 hour lifetime
- Color Rendering up to 96 CRI
- Already in use for arena, street lighting
- Fixtures by Stray Light

“Alpha” H₂/Fuel Cell Mobile Light (10/2009)

Alpha system built by Multiquip, Alteryg Systems, Luxim, Stray Light



-- funded by Boeing, with in-kind \$ from Multiquip, Alteryg Systems and others

Employs two 5000 psi tanks of H₂ (4.2kg)

Alteryg 5kW PEM fuel cell

8 Luxim Plasma Lights (~2.1 kW total)

Multiquip Trailer

~ 30 hour duration

The Alpha system provided critical early learning and allowed Multiquip to gain familiarity with the technology.



We provided high-pressure manifolding training to MQ, so they “own” the capability.

The Project Got a Boost Forward When Demonstrated at Paramount on 1/14/2010



Briefing to LA Fire Dept.
and Building Safety



Candace and Russell Saunders,
Saunders Electric



Mark Bauserman,
formerly Chief Engineer
Paramount Studios

The project team was invited to deploy Fuel Cell Mobile Lighting
at the Academy Awards in Hollywood on March 7, 2010

At the Academy Awards



2010 Academy Awards Red Carpet Build-up

Used on the Red Carpet at the 2010/2012 Oscars, 2011 Grammys, 2011/2012 Golden Globes, 2011/ 2012 Screen Actors Guild (SAG) Awards

Introduction of the technology to these industries, through Saunders Electric and entertainment construction personnel, naturally leads to the development of the entertainment early market.

Spreading the Word About Fuel Cells at the 2012 SAGs



Jae Je Simmons,
Executive Dir.
New York Division
Screen Actors
Guild



Chris Radley, Altery
LA Police Department



Johnny Galecki,
Actor,
The Big Bang
Theory



Saunders Electric: A Strong Advocate for Fuel Cells in Entertainment

- Saunders is power technology leader in Hollywood.
 - Provides high end access for exposure of H₂ Fuel Cells at televised events since 2010 via the delivery and use of the H₂LT.
 - Receives constant inquiries about future development of H₂ Fuel Cell availability for use in the entertainment industry
 - Has presented H₂ fuel cell technology to NRDC, ESPN, National Hockey League, Broadway Green Alliance
 - Has received only positive feedback industry wide on H₂ Light Tower – simplicity and ease of use are key
- Entertainment industry needs larger “Green” portable KW power sources
 - As H₂ refueling options are more available, H₂ fuel cell more viable

“Beta” Fuel Cell Mobile Light Capabilities



*Beta Fuel Cell Mobile Light
Running at World of Concrete 2011*



- ~66 hour duration (LED lighting only)
-- 4 H₂ Tanks
- Indoor or outdoor use
- Area of illumination: 50 yds x 75 yds
(at 3.5 foot candles)
- ~1.5 kW of AC power as option
- Easily moved
- Quiet: 43 dB noise level at 23 feet
← (--- and can be reduced)
- 30 foot tower height, fully rotatable

Caltrans Winter Use Near Lake Tahoe Was Demanding, and the Test Was Passed



The Caltrans Fuel Cell Mobile Light has been towed over 1100 miles on mountain roads, without damage to the tanks or hydrogen manifolding

H₂LT Used at NASA for 1-Year, and at the Last Space Shuttle Launch (Atlantis)



Fuel Cell Mobile Light with shuttle astronaut George Zamka



Lift-off of Atlantis

H₂LT used to provide lighting in the International Press Area

1500 members of international press in attendance.



Interview with BBC Radio

After a year of use in the hot, humid and salty air, the system performed without failure. NASA corrosion engineers inspected the H₂LT, and reported their observations to Multiquip.

U.C. Davis/Caltrans Testing of H₂LT Lighting



AHMCT team



Advanced Highway Maintenance and Construction Technology (AHMCT) Research Center of U.C. Davis, funded by Caltrans

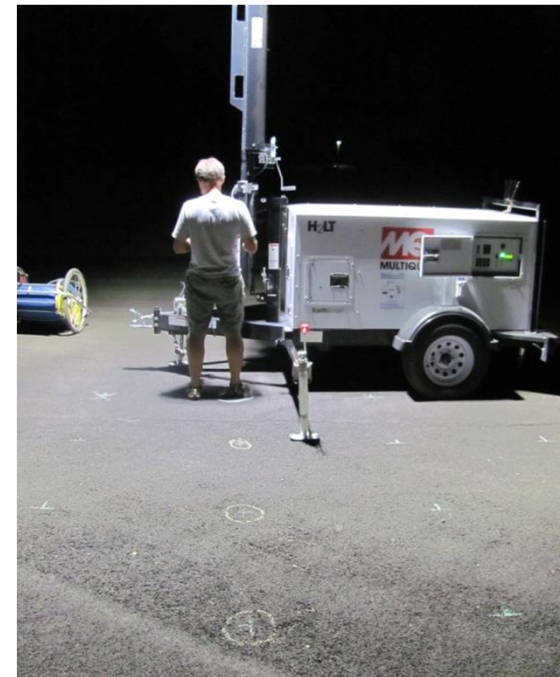

AHMCT Testing of H₂LT Lighting Compares Lighting Area and Efficiency

| Light Type | Fixture Power Consumption (W) | Efficiency (lm/W) |
|--------------|-------------------------------|-------------------|
| LED | 408 | 54.3 |
| Plasma | 476 | 38.4 |
| Metal Halide | 1392 | 35.0 |

LED lights will be used in the Multiquip commercial H₂LT

-- results for one fixture each:

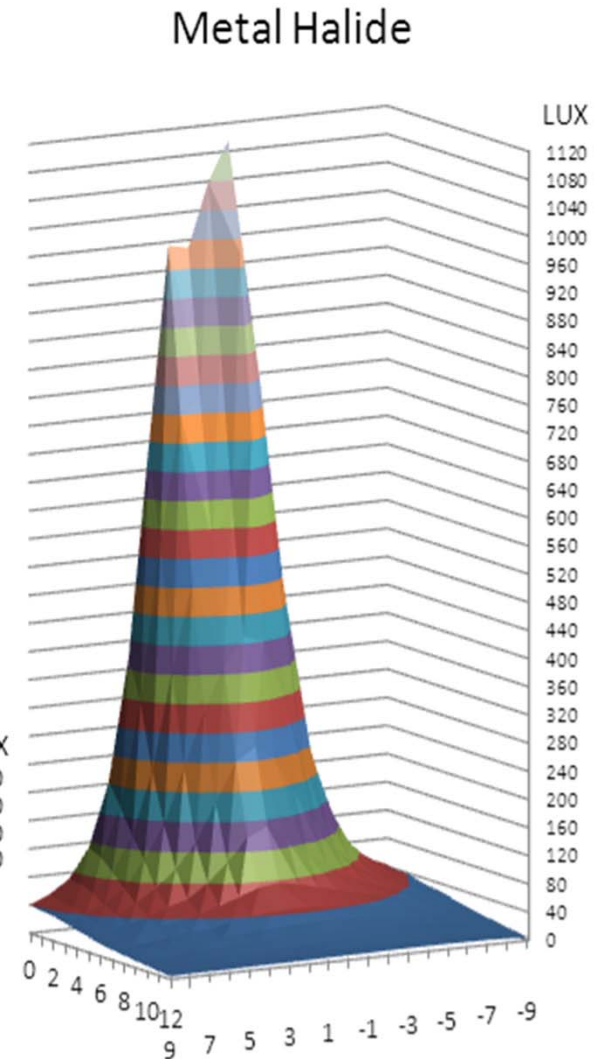
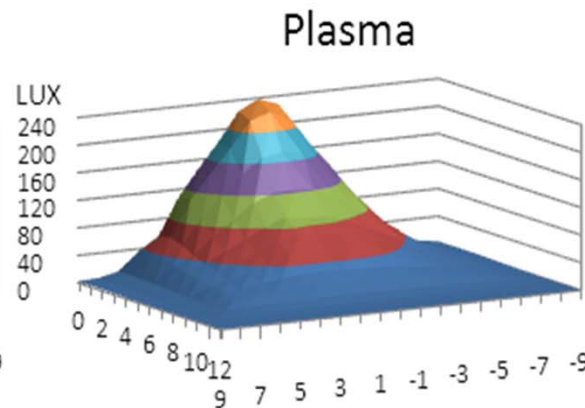
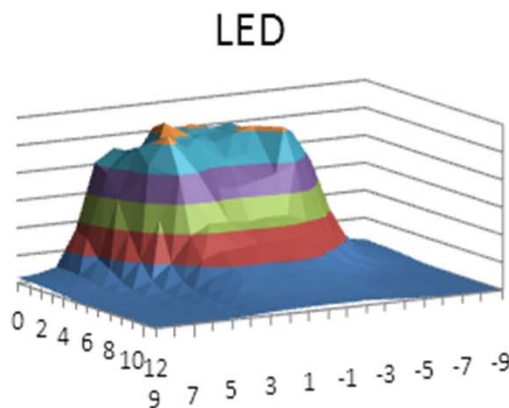

Horizontal Grid in Meters

Efficiency and GHG Savings

MH Light Towers: 35.0 lm/W MH lighting combined with 25% diesel engine efficiency

LED/H₂LT: 54.3 lm/W LED lighting efficiency combined with 47% PEM Fuel Cell efficiency

Thus, the LED/H₂LT consumes 65% less fuel energy than the conventional MH/diesel light tower.

In typical use, a tower is used ~180 days a year, for 10 hours a day. That suggests a H₂LT displacement of ~ 1100 gallons of diesel fuel/unit/year.

If NG is used to make the hydrogen, we estimate* that the GHG reduction is 60% for the same light output. The Altery fuel cell is classified by CARB as “zero emissions” at point of use.

If “zero-carbon” hydrogen is used (H₂ from wind, solar, nuclear), then the GHG reduction is 96 - 98%.

*GHG estimates from “Well-to-Tank Report” of European Commission Analysis of Future Automotive fuels and powertrains in the European Context”, 2007.

Design Lessons Arising from Field-test Problems

| The Problem | The Design Solution |
|--|---|
| 1. Fuel Cell voltage tap connections can come loose with vibration. | Redesign voltage taps so it is impossible to shake loose |
| 2. FC purge line pinched closed during assembly | Check purge line during assembly to exclude such a pinch |
| 3. Plasma lights work intermittently due to motion. | Switch to LED technology |
| 4. H ₂ Tank valve stuck in open position | Replacing valve, will assess cause |
| 5. Plasma light glass covers break during transit | Switch to LED lights with break-resistant covers |
| 6. Main winch severely rusted after KSC use | Will replace with a more corrosion-resistant winch |
| 7. Operating Auxiliary Power can cause FC shutdown | Grounding issues being resolved |
| 8. TN1 fill port is not easily filled filled from bottled H ₂ | Provide hose with fittings appropriate for connecting TN1 to bottles as option with unit. |
| 9. Voltage at top of mast reduced due to IR drop in mast cables | Switch to LED lights which can be fully powered at the reduced voltage |
| 10. If FC waste heat vent is on top of cabinet, snow can enter | Place FC waste heat vent on the side of the unit |

Commercial H₂LT Fuel Cell Mobile Light

Commercialized by Multiquip Inc.

New Technology Platform: EarthSmart[®]

H₂LT will be available for sale Q1 2013

Last month, MQ announces the second Earthsmart[®] Product: the H₂G 5kW Portable Fuel Cell Generator



Original H₂LT product brochure

- ✓ Zero emissions, Quiet
- ✓ Can be used indoors
- ✓ Provides auxiliary power



CRC Press
Taylor & Francis Group
A TAYLOR & FRANCIS BOOK

Hydrogen Storage Technology

Materials and Applications

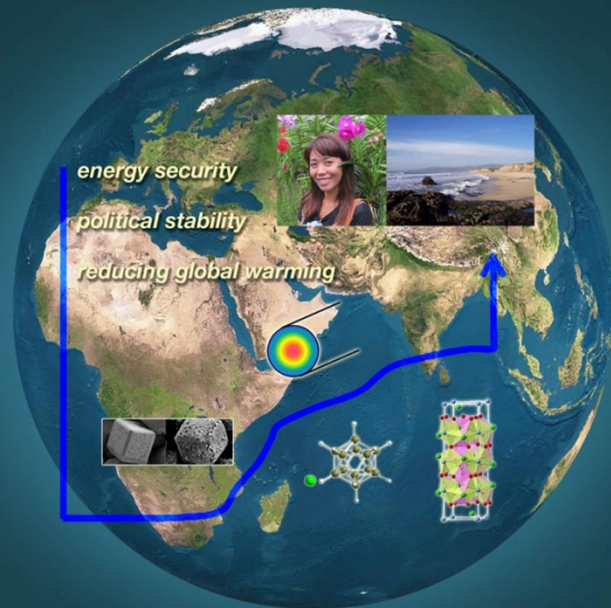

Edited by
Lennie Klebanoff

The use of Fuel Cells in the construction equipment and portable power application is discussed in an upcoming book, due out December 19, 2012

--published by CRC Press

Topics:

- Why we need H₂-based energy
- H₂ Energy Conversion Devices
- All methods of H₂ Storage
- Engineered H₂ Storage Systems
- H₂ Codes and Standards

-- pre-ordering available now
from crcpress.com

Do a search on Lennie Klebanoff
at the crcpress.com and it will
bring you to the book



NASA KSC



Saunders Electric, Inc.



Boeing



U.C. Davis AHMCT



The First 7



Santa Monica H₂ Station



Caltrans District 3, DRI



California Fuel Cell Partnership

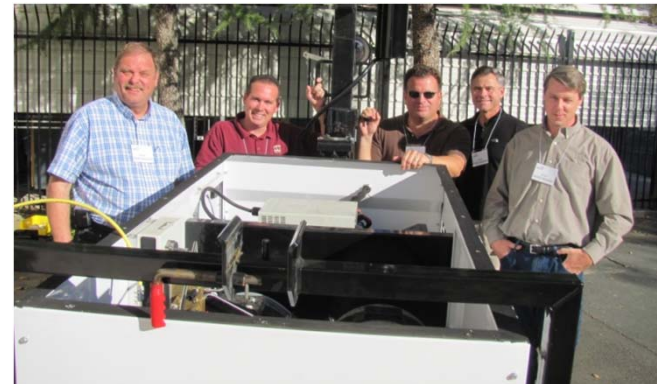

Multiquip Inc.

Project Funding

**Funding from DOE enabled a much larger project,
and stimulated significant cost share by our partners:**

DOE Fuel Cell Technologies,
Market Transformation: \$650K (thanks Pete!)

+ “In-kind” funding from the Circle of Love: \$1.70M

Total Project Funding = \$2.35M

Awards for the Fuel Cell Mobile Light

1. 2012 Federal Laboratory Consortium (FLC) National Award for Excellence in Tech Transfer, for Fuel Cell Mobile Light Project, May 3, 2012
2. 2011 Rental Equipment Magazine “Grand Prize” for Innovative Technology, December 20, 2011
3. 2011 DOE Hydrogen and Fuel Cells Program R&D Award, “In recognition outstanding contributions to Fuel Cell Market Transformation Activities,” May 11, 2011
4. Fuel Cell Mobile Light Awarded 2011 “Editors Choice Award” for Most Innovative New Product in “General Equipment” – World of Concrete 2011, February 15, 2011.

Acknowledgements– Fuel Cell Mobile Light

Boeing: Joe Breit, George Roe, Ty Larsen

DOE (EERE): Pete Devlin, Nancy Garland,
Greg Moreland (SRA)

Sandia-CA: Jay Keller, Terry Johnson,
Andrew Socha, Marcina Moreno, Daniel Dedrick



Other Fuel Cell Mobile Light Project Partners:

Multiquip Inc.: Torsten Erbel, Steve Wingert, Jonathan Cuppett, Bruce Coleman

Altery Systems: Mickey Oros, Chris Radley, Paul Schuttinger, Terry Carlone

Stray Light Optical Technologies: Gerald Rea, Robert Drake

Caltrans: Randy Woolley, Steve Prey, Larry Orcutt

Saunders Electric Inc.: Russ Saunders and Candace Saunders

California FC Partnership: Bill Elrick, Nico Bouwkamp, Jen Hamilton, Jordan McRobie

Ovonic Hydrogen Systems: Mike Zelinsky, Ben Chao

San Francisco International Airport: Roger Hooson, Derek Fliess

Golden State Energy: Tom Damberger

Luxim: Geoff Brown

Lumenworks: Thomas Skradski

U.C. Davis AHMCT: Steve Velinsky, Wil White, Sean Donohoe, Lauren Miller, K.S. Yen



The Fuel Cell Mobile Light Project
-- A DOE Market Transformation Activity--

Chris Radley
Vice President, Product Line Management

DOE Fuel Cell Technologies Webinar

November 13, 2012

About Alteryg – Manufacturing Process

- Alteryg designs and manufactures the *Freedom Power™* series of fuel cell products
- These products deliver on the promise of fuel cells:
 - Clean, green, abundant, low-cost power
 - Alteryg's breakthrough, patented technology makes them commercially viable today!
 - Highly differentiated approach results in fuel cells designed specifically for manufacturability
 - Fuel cells plates that can be made by the thousands per day
 - Utilizing low cost materials, high volume fabrication processes and automated assembly
 - Using the world's first and only high volume, automated/robotic assembly line
 - Strategic partners provide global footprint by selling, installing and servicing on a world wide basis



EnerSys

EATON

Product Transition



Standard Telecom Installation

Standard Backup Power Product



5kW Fuel Cell Engine

Alteryg's standard product offering was able to transition seamlessly from a telecom backup power application to a mobile power source due to its modular design

Fuel Storage System Design



Alteryg's Standard Fuel Storage Offerings

**SAE Requirements
NFPA Requirements**

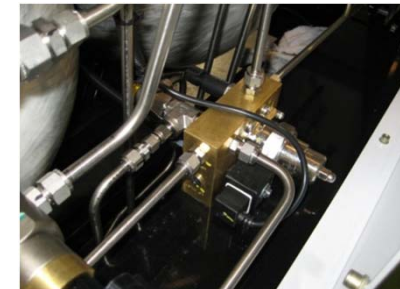
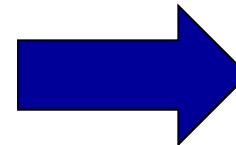
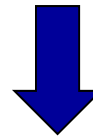

Alteryg's Refueling Knowledge

Alteryg's fuel storage knowledge coupled with the applicable industry and Code requirements were incorporated in the fuel cell mobile light system design



H₂LT Cold Weather Operation

- Cold weather operation was achieved by replicating the standard backup power enclosure on the mobile light trailer.
- This provided for operation down to -20C
- Cold weather start was achieved through the use of strategically placed heater systems and the ability to have a delayed start

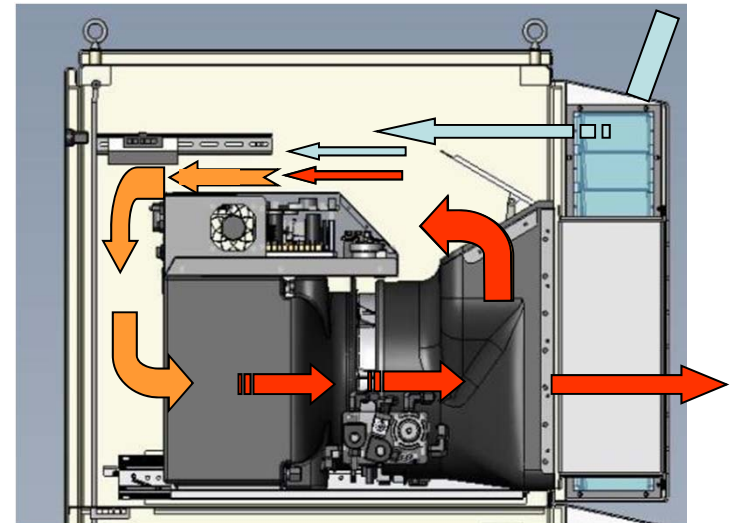

Altergy's Impression of the Fuel Cell Mobile Light Project

- **Very positive experience**
 - **The partners selected were the top echelon partners in their field of responsibility**
 - **Team was very professional and open with exchanging data**
 - **All team members were willing to help for the betterment of the group**
- **Altergy would be very supportive of future similar activities**
- **Altergy never would have moved into this market without the encouragement of this project**
- **Positive feedback from the user community**
- **See the need to transition this to production ASAP to not lose the momentum in the market**
- **This project's platform now opens up further product opportunities which were not originally anticipated**

The Fuel Cell Mobile Light Project -- A DOE Market Transformation Activity--

Hydrogen Power Technology Platform Overview

Torsten Erbel

*Vice President for Product Development
Multiquip Inc.*

DOE Fuel Cell Technologies Webinar

November 13, 2012



Benefits of Hydrogen and PEM Fuel Cells

Fuel cells offer clean, continuous, uninterruptable, high-quality electrical power from hydrogen

Fuel cells can use renewable resources (hydrogen) – a responsible use of natural resources

Hydrogen can be produced from a variety of sources (fuel resource security)

No Green House Gases (GHG) are generated from fuel cell operations

Fuel cells operate very quietly, even without noise attenuation

Fuel cells offer power generation with few moving parts, better reliability

Fuel cells offer high efficiency in fuel-to-energy conversion (around 50%)

Fuel cells are compact, with high power density, giving a small foot print

Fuel cells generate no CO₂ and can be operated indoors, in tunnels or underground

Fuel cells generate no spark and are safe to use around highly flammable or explosive areas



Fuel Cell Benefits & Challenges

Fuel cells require very little to no maintenance

Fuel cells, due to the high energy efficiency, require less fuel than conventional generator

Fuel cells are load following and generate only as much power as demanded. Traditional generator engines always operate at full speed and generate maximum power if needed or not

Fuel cells offer lower operating costs than traditional generators

Challenges

Initial investment cost is higher than traditional generators

Hydrogen fuel is not as readily available as diesel fuel

Limited public knowledge about fuel cells, hydrogen and hydrogen safety

Although around for several decades, fuel cells are still considered “new technology” with few commercial suppliers and offerings



H₂LT and H₂G Design Features

(4) 5000 psi SCI tanks
(8.4 kg H₂ total) with
strong steel mounting
brackets for firm seating



Steel stabilizer bars
protect from impact





Standard Safety Features

Each H₂ tank is equipped with a standard Thermal Pressure Relief Device (TPRD)

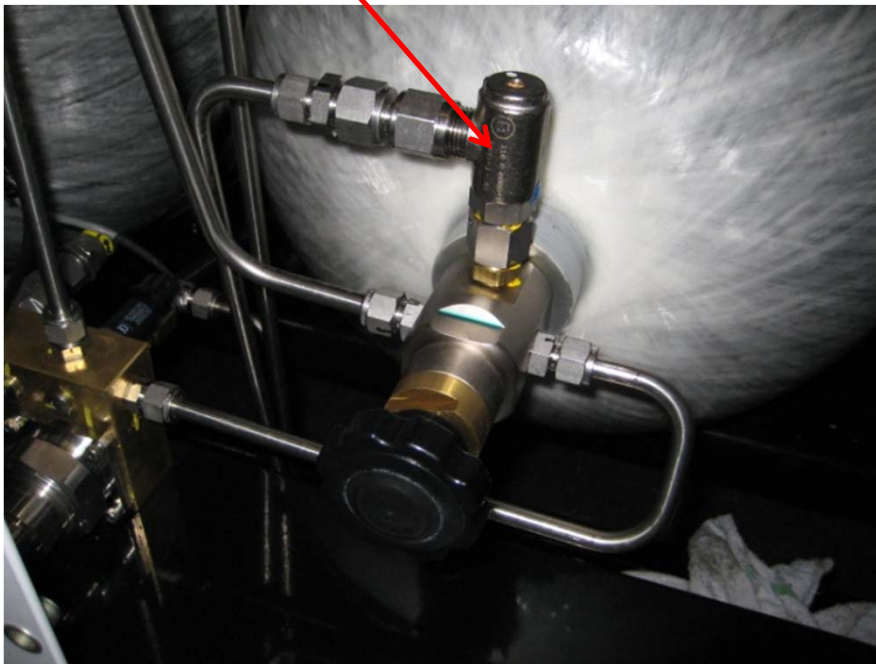

All tanks are fed from a manifold of 316 stainless steel tubing rated for 6500 psi. All H₂LT units extensively pressure and leak checked before shipping.

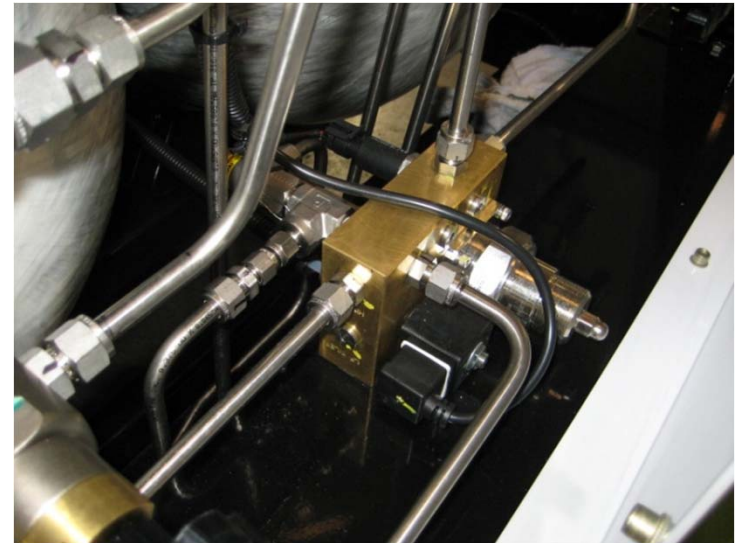



Hydrogen Power Features

An optional AC inverter is available if 120VAC power is required



Standard Alteryg 5kW fuel cell provides 28 V DC

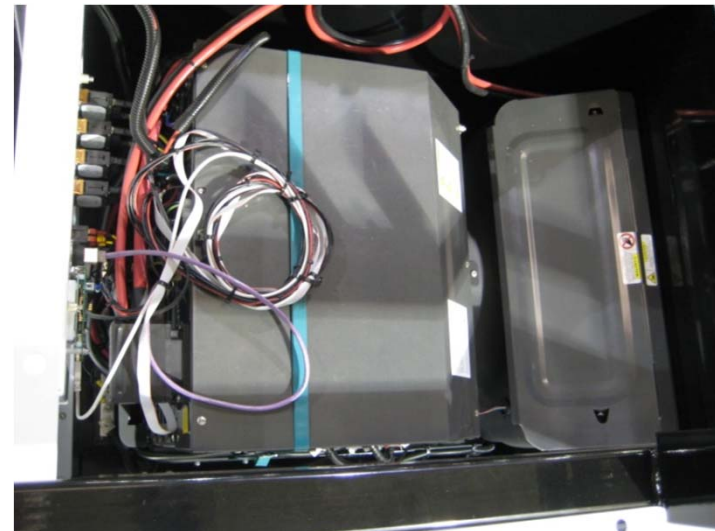



Building up the System

Trailer is constructed from heavy duty steel channel



For additional safety the fuel cell is mounted to the back of the trailer, protected by a heavy duty impact channel





H₂LT and H₂G Security

All fuel tank, refueling and control panel access doors are lockable for safety and security for access by authorized users only.



The unit can be towed behind a pick-up truck using standard hardware....



Fueling and Control

TN1 connection port, for filling by H₂ Station or H₂ Bottles

Fuel access door features an automotive style, 5000 psi (350 bar) TN1 port, fill selector and fuel gauge



Control panel with remote display and operation function from fuel cell. Built-in Service and maintenance ports





H₂LT, H₂G Safety Compliance

- **Fuel Cell:**

- Meets or exceeds the requirements of:
- The State Fire and Building codes
- NFPA-1 – Uniform Fire Code
- NFPA 55 – Standard for Storage, use and handling of compressed gases and cryogenic fluids in portable and stationary containers, cylinders and tanks
- NFPA 853 – standard for the installation of stationary fuel cell power systems
- NFPA 70 – The National Electric Code (NEC)
- The International Fire Code (IFC)
- CSA FC 1 – Standard for stationary fuel cell power systems
- ANSI/CSA FC 1-2004 Fuel Cell standard

- **Tanks:**

- US DOT-SP 10945-5000
- KHK/METI (Japan) ECE R110 (Europe)
- ISO11439 (Europe) FMVSS 304 (United States)
- CSA B51 (Canada) ANSI NGV2 (North America)



Many Customers are Concerned about Equipment Noise

Common Sound levels in the Environment

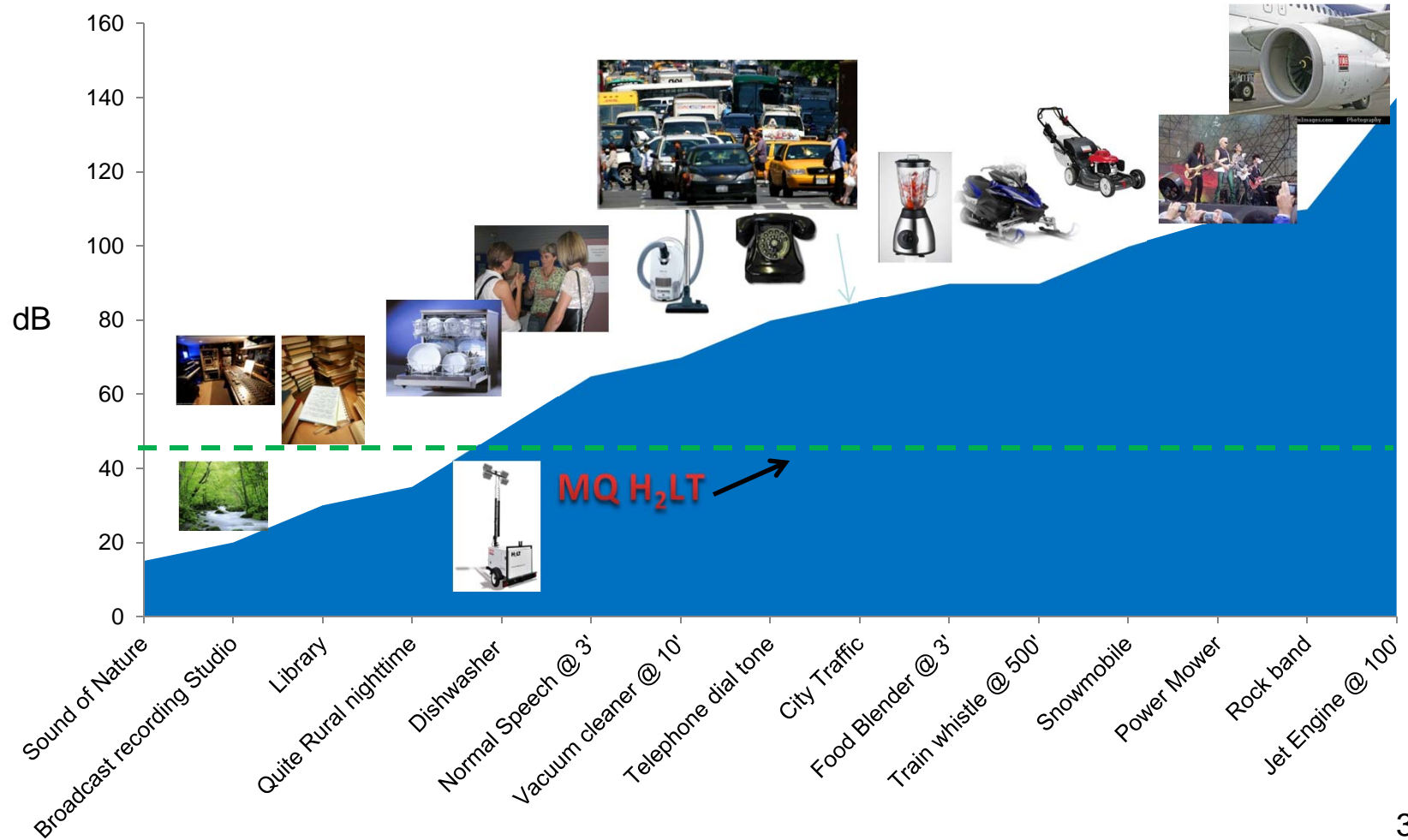



H₂ FC Power Technology is Dramatically Quieter Than Diesel Technology

Multiquip's standard, most popular DCA 25kW and 45kW generators and our premium "Ultra Silence" generators in noise comparison to hydrogen powered units. These are the quietest diesel systems on the market.

Additional noise reduction in the H₂LT and H₂G can be achieved with sound attenuation, presently not deployed in the H₂ powered units.

Noise Comparison in dB Generator vs. Fuel Cell (measured at 23 feet)

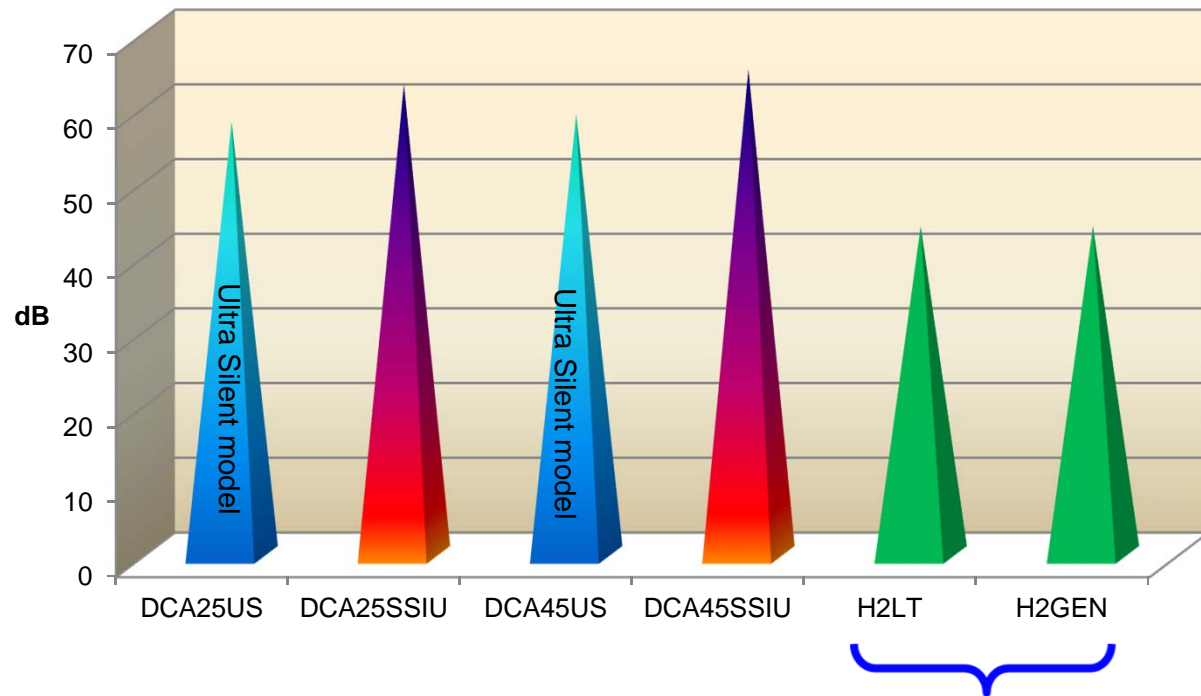



Some 2000 hr. Operating Cost Data

Operating a standard generator or a fuel cell powered units for 2,000 hours based on the aforementioned criteria and applying all engine factory required maintenance and periodic inspections. This reflects total parts and labor costs. Los Angeles shop labor rate \$90/hour. In a typical rental environment this represents approx. (1) year of operation for mobile generators, not deployed for standby operation.

2000 Hour Operating costs incl. Unit acquisition costs (without Energy Tax credits)

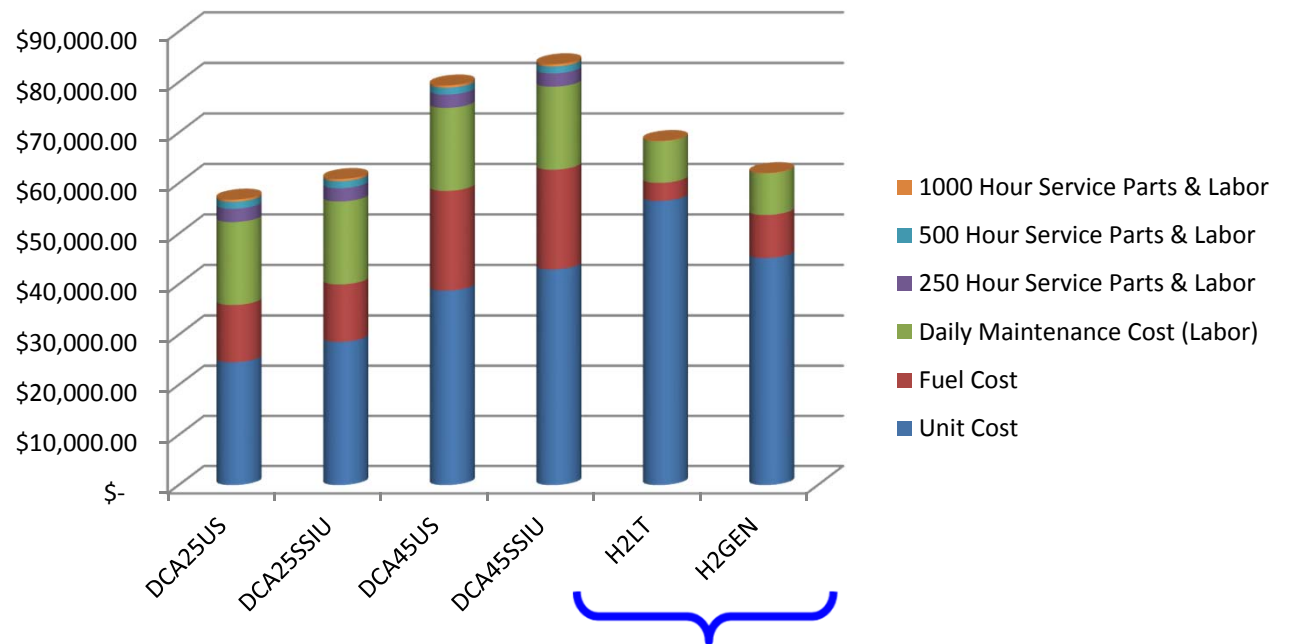



...and for 10,000 hr operation

As in the previous chart, but for operation expanded to **10,000** hours or approx. **5 years**.

Considerable savings are recognized in fuel consumption and maintenance costs for the hydrogen powered units. The hydrogen powered generator operates **59.4% lower** than a DCA 25 and **66.2% lower** than a DCA 45

10,000 Hours Operation Cost estimates Generators vs. Fuel Cell units (no Energy tax Credit consideration)

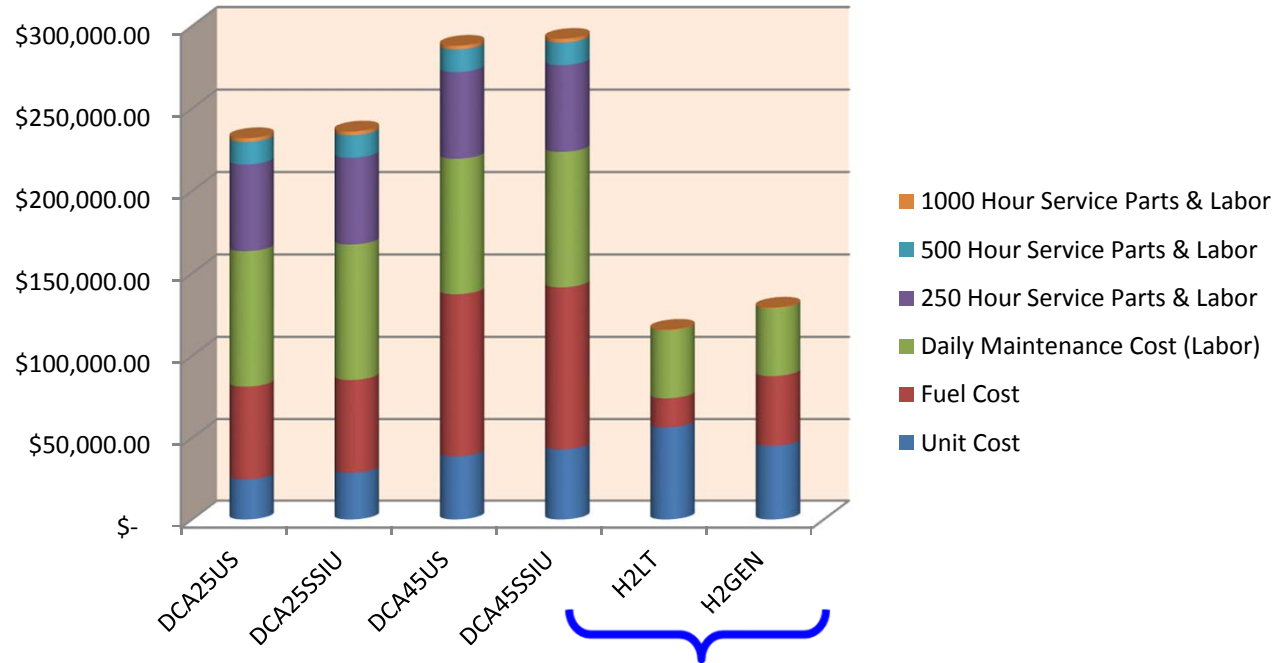



EarthSmart™: Multiquip's H₂ Technology Platform

- H₂LT and H₂G units to be commercially released 1Q 2013
- H₂ Technology supported by Top MQ Management
- Future additional products in review
- Created **EarthSmart™** technology platform
- Working with Greg Moreland on Finance Package
- Would benefit from H₂ Highway expansion



Project Impact on Multiquip

- Participating in the Fuel Cell Mobile Light Project has had a profound impact on Multiquip, Inc.
- Exposed and entered the company into a technology we would not have pursued.
- Created a new technology platform for our company.
- Added new product lines to our offerings.
- Generated acknowledgement from our parent company for innovative and forward thinking.
- Gave us the opportunity to work with leading companies and gain knowledge from their expertise.
- Had great project support. It was a wonderful experience for our company's team members.
- It broadened our view and exposed us to the benefits of working outside the company on a development project
- We have gained many new friends, business partners and enjoyed an enormous amount of support.

Questions?



Lennie Klebanoff
Tel: 925-294-3471
lekleba@sandia.gov

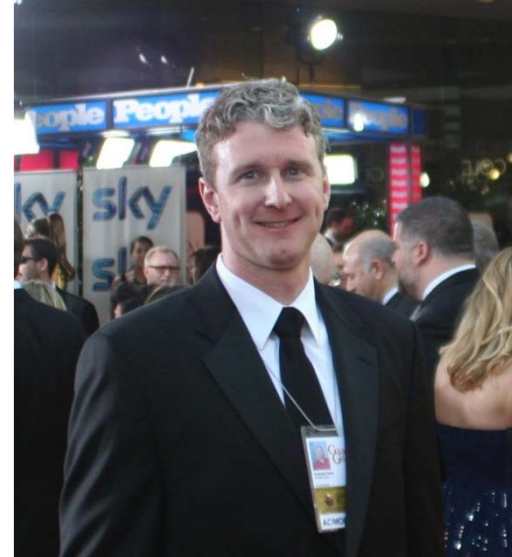

Chris Radley
Tel: 916-458-9409
chris.radley@altery.com



Torsten Erbel
Tel: 310-400-1306
terbel@multiquip.com