

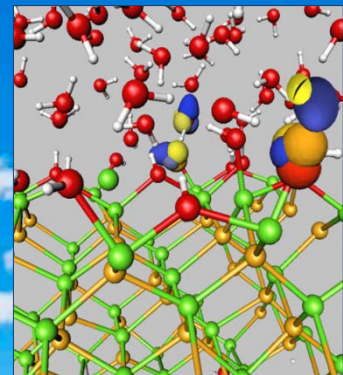

Hydrogen Production Technical Team Roadmap

June 2013



This roadmap is a document of the U.S. DRIVE Partnership. U.S. DRIVE (Driving Research and Innovation for Vehicle efficiency and Energy sustainability) is a voluntary, non-binding, and nonlegal partnership among the U.S. Department of Energy; USCAR, representing Chrysler Group LLC, Ford Motor Company, and General Motors; Tesla Motors; five energy companies —BP America, Chevron Corporation, Phillips 66 Company, ExxonMobil Corporation, and Shell Oil Products US; two utilities — Southern California Edison and DTE Energy; and the Electric Power Research Institute (EPRI).

The Hydrogen Production Technical Team is one of 12 U.S. DRIVE technical teams (“tech teams”) whose mission is to accelerate the development of pre-competitive and innovative technologies to enable a full range of efficient and clean advanced light-duty vehicles, as well as related energy infrastructure.

For more information about U.S. DRIVE, please see the U.S. DRIVE Partnership Plan, www.vehicles.energy.gov/about/partnerships/usdrive.html or www.uscar.org.

Table of Contents

Acknowledgments	vii
Introduction	1
<i>Hydrogen Production</i>	1
DOE R&D Leadership.....	1
Types of Technologies.....	2
Production Scales and Locales	3
Seven Major Technology Pathways.....	4
Timeline, Feedstocks, and Energy Sources	4
Key Roadmap Elements	5
DOE Threshold Cost	5
Common Technology Barriers	7
Community Acceptance Barriers	7
Critical Technology Needs.....	9
Path Forward.....	10
1.0 Distributed Natural Gas Reforming	11
1.1 <i>Current Technical Status and Technical Targets</i>	11
Cost Projections	12
1.2 <i>Gaps and Technical Barriers</i>	12
Reformer Capital Costs	12
Reformer Manufacturing.....	12
Station Footprint.....	13
Operations and Maintenance Costs	13
Feedstock Issues	14
Control and Safety	14
1.3 <i>Strategy to Overcome Barriers and Achieve Technical Targets</i>	15
Reduce Reformer Capital Costs	15
Reduce Operating and Maintenance Costs	17
2.0 Bio-derived Liquids Reforming	19
2.1 <i>Current Status and Technical Targets</i>	19
DOE Cost Targets	21
2.2 <i>Gaps and Technical Barriers</i>	21
Reformer Capital Costs	21
Reformer Manufacturing.....	22
Station Footprint.....	22
Feedstock Issues	22
Operations and Maintenance	23
Control and Safety	23
2.3 <i>Strategy to Overcome Barriers and Achieve Technical Targets</i>	23
Reduce Capital Costs.....	24
Reduce Operations and Maintenance Costs	26
3.0 Coal and Biomass Gasification	31
3.1 <i>Current Status and Technical Targets</i>	31

DOE Cost Targets	31
Coal and Biomass Feedstocks	32
3.2 Gaps and Technical Barriers	32
Emissions (Primarily Coal).....	33
Feedstock Issues (Primarily Biomass)	34
Capital Costs.....	34
Operations and Maintenance	35
Control and Safety	35
3.3 Strategy to Overcome Barriers and Achieve Technical Targets	36
Reduce Capital Costs.....	36
Reduce Operations and Maintenance Costs	37
4.0 Water Electrolysis	39
4.1 Current Status and Technical Targets	39
DOE Cost Targets	39
Production Scale	39
4.2 Gaps and Technical Barriers	41
System Efficiency and Electricity Cost	41
Renewable and Nuclear Electricity Generation	42
Capital Costs.....	42
Manufacturing	43
Operations and Maintenance	43
Grid Electricity Emissions	44
Control and Safety	44
4.3 Strategy to Overcome Barriers and Achieve Technical Targets	44
Reduce Capital Costs.....	45
Reduce Operations and Maintenance Costs	47
5.0 Solar Thermochemical Hydrogen	49
5.1 Current Status and Technical Targets	49
Solar Thermochemical Hydrogen Technology	49
DOE Cost Targets	52
5.2 Gaps and Technical Barriers	52
Thermochemical Cycle Selection	54
Materials Development	54
Chemical Reactor Development	55
Solar Receiver Development.....	55
Solar Intermittency	56
Solar Concentrator Technologies.....	56
Operations Costs.....	56
Land and Capital Costs.....	56
5.3 Strategy to Overcome Barriers and Achieve Technical Targets	56
6.0 Photoelectrochemical	59
6.1 Current Status and Technical Targets	59
PEC Technology.....	59
DOE Cost Targets	63

6.2	<i>Gaps and Technical Barriers</i>	64
	Conversion Efficiency	64
	Materials/Interface Durability	65
	Materials Cost	65
	Auxiliary Materials	65
	Integrated Devices	65
	System-Level Considerations	66
6.3	<i>Strategy to Overcome Barriers and Achieve Technical Targets</i>	66
7.0	Photobiological	68
7.1	<i>Current Status and Technical Targets</i>	68
	Photobiological Technology.....	69
	Combined Systems.....	71
	DOE Cost Targets	71
7.2	<i>Gaps and Technical Barriers</i>	72
	Common Photobiological Microorganism Barriers	73
	Photofermentative Bacterial Hydrogen Production.....	76
	Combined Biological System.....	76
	System Design	77
7.3	<i>Strategy to Overcome Barriers and Achieve Technical Targets</i>	77
8.0	Fermentation	79
8.1	<i>Current Status and Technical Targets</i>	79
	Dark Fermentation.....	79
	Combined Systems.....	81
	DOE Cost Targets	82
8.2	<i>Gaps and Technical Barriers</i>	82
	Microorganism Characterization	84
	Dark Fermentative Hydrogen Production.....	84
	Microbial Electrolysis Cell Hydrogen Production.....	85
	Combined System	85
	Operations and Maintenance	86
8.3	<i>Strategy to Overcome Barriers and Achieve Technical Targets</i>	86
Appendix A: Acronyms and Initialisms		89

List of Figures

Figure I.1.	Technology Pathway Development Timelines, Feedstocks, and Energy Sources for Hydrogen Production.....	5
Figure 5.1.	Examples of Solar Thermochemical Cycles for Hydrogen Production	50
Figure 5.2.	Tower and Dish-Mount STCH Receiver–Reactor Configurations	51
Figure 6.1.	PEC Solar Water-splitting Reactors–(a) photo-electrode and (b) photocatalyst-particles.....	60
Figure 6.2.	Photon absorption, band bending, charge separation, and hydrogen and oxygen evolution on semiconductor photoanode and photocathode surfaces are shown	61

Figure 6.3. PEC Photocatalyst Reactor. Particles may be dispersed in low-cost plastic containers for separate H ₂ and O ₂ evolution.....	62
Figure 7.1. Photobiological Pathways.....	70
Figure 8.1. Microbial Electrolysis Cell	81

List of Tables

Table I.1. DOE Partners in Hydrogen Production R&D	2
Table I.2. Major Hydrogen Production Technology Pathways	4
Table I.3. DOE Hydrogen Production Cost Reduction Goals (\$/gge produced)	6
Table I.4. Pathways Forward	10
Table 1.1. Distributed Natural Gas Reforming — Cost Projections.....	12
Table 1.2. Distributed Natural Gas Reforming — Summary of Barriers.....	13
Table 1.3. Distributed Natural Gas Reforming — Critical Technology Needs	15
Table 2.1. Distributed Forecourt Production of Hydrogen from High-Temperature Ethanol Reforming — DOE Cost Targets.....	21
Table 2.2. Bio-derived Liquids Reforming — Summary of Barriers.....	22
Table 2.3. Bio-Derived Liquids Reforming — Critical Technology Needs.....	24
Table 2.4. Potential Bio-Liquid Reforming Feedstocks.....	29
Table 3.1. Biomass Gasification Hydrogen Production — DOE Cost Targets.....	32
Table 3.2. Coal and Biomass Gasification — Summary of Barriers	33
Table 3.3. Coal and Biomass Gasification — Critical Technology Needs.....	36
Table 4.1. Water Electrolysis — DOE Cost Targets (\$/ggea)	40
Table 4.2. Water Electrolysis — Summary of Barriers	41
Table 4.3. Water Electrolysis — Critical Technology Needs.....	44
Table 5.1. Solar-Driven High-Temperature Thermochemical Hydrogen Production — DOE Cost Targets	52
Table 5.2. Solar Thermochemical Hydrogen — Summary of Barriers.....	53
Table 5.3. Solar Thermochemical Hydrogen — Critical Technology Needs in Promising Cycles	57
Table 6.1. Photoelectrochemical Production Pathways — DOE Cost Targets	63
Table 6.2. Photoelectrochemical Hydrogen Production — Summary of Barriers.....	64
Table 6.3. Photoelectrochemical — Critical Technology Needs.....	66
Table 7.1. Photobiological Hydrogen Production — DOE Cost Targets	72
Table 7.2. Photobiological Hydrogen Production — Summary of Barriers.....	72
Table 7.3. Photobiological Hydrogen Production — Critical Technology Needs	77
Table 8.1. Biological Hydrogen Production — DOE Cost Target	82
Table 8.2. Fermentative and MEC Hydrogen Production — Summary of Barriers.....	83
Table 8.3. Fermentative and MEC Hydrogen Production — Critical Technology Needs	86

Acknowledgments

Hydrogen Production Technical Team Organizational Members

Chevron
ExxonMobil
Phillips 66
Shell Oil Products US
National Renewable Energy Laboratory
Pacific Northwest National Laboratory
U.S. Department of Energy, Fuel Cell Technologies Office
U.S. Department of Energy, Office of Fossil Energy

Hydrogen Production Roadmap Contributors

Contributor	Affiliation
Guido Dehoratiis	U.S. Department of Energy, Office of Fossil Energy
Sara Dillich	U.S. Department of Energy, Fuel Cell Technologies Office
Katie Randolph*	U.S. Department of Energy, Fuel Cell Technologies Office
Eric Miller**	U.S. Department of Energy, Fuel Cell Technologies Office
Erika Sutherland**	U.S. Department of Energy, Fuel Cell Technologies Office
David Peterson**	U.S. Department of Energy, Fuel Cell Technologies Office
Sarah Studer**	AAAS Science & Technology Policy Fellow, U.S. Department of Energy
Herie Soto*	Shell Oil Products US
Frank Hershkowitz	ExxonMobil
Jamelyn Holladay	Pacific Northwest National Laboratory
Carl Sink	U.S. Department of Energy, Office of Nuclear Energy
Tecele Rufael	Chevron
George Parks	Phillips 66
Mark Ruth	National Renewable Energy Laboratory
Tom Jarvi	Sun Catalytix

* HPTT Co-Chairs

** DOE FCTO P&D Team Roadmap Contributors

Introduction

The mission of the Hydrogen Production Technical Team (HPTT) is to enable the development of hydrogen production technologies, using clean, domestic resources, which will allow for an as-produced, delivered, and dispensed cost of \$2 to \$4 per gasoline gallon equivalent (gge) of hydrogen. This aim supports U.S. DRIVE Partnership Goal (2), which is to enable reliable fuel cell electric vehicles (FCEVs) with performance, safety, and costs comparable to or better than advanced conventional vehicle technologies, supported by viable hydrogen storage and the widespread availability of hydrogen fuel.

The scope of hydrogen production is broad and covers a wide variety of renewable and low-carbon-emission hydrogen production pathways. The development of hydrogen production pathways will include consideration of a wide range of factors including feedstock cost and availability, greenhouse gas (GHG) emissions, hydrogen purity, the capital costs of the production facilities as well as the efficiency of the production pathways. Different production scales are also considered ranging from distributed production (up to 1,500 kg H₂ per day) to semi-central and central production facilities (up to 500,000 kg or more H₂ per day).

The aim of the roadmap is to identify research pathways leading to hydrogen production technologies that produce near-zero net greenhouse gas (GHG) emissions from highly efficient and diverse renewable energy sources. This roadmap focuses on initial development of the technologies, identifies their gaps and barriers, and describes activities by various U.S. Department of Energy (DOE) offices to address the key issues and challenges.

The purpose of the roadmap is to facilitate development of commercial hydrogen production via various technology pathways in the near and long terms. DOE's goal is to reduce the cost of hydrogen production to ≤\$2.00 per gge¹ (\$2.00 to \$4.00 delivered and dispensed²) by 2020.

Hydrogen Production

DOE R&D Leadership

The mission of the DOE Fuel Cells Technologies (FCT) Office is to enable the widespread commercialization of a portfolio of hydrogen and fuel cell technologies through applied research, technology development and demonstration, and diverse efforts to overcome institutional and market challenges. The office is organized into distinct sub-programs that address the specific research and supporting activities needed to overcome the barriers to hydrogen and fuel cell commercialization, including hydrogen production and delivery; hydrogen storage; fuel cells; technology validation; market transformation; safety, codes and standards; education; and systems analysis and integration.

Within the DOE FCT Office, work on hydrogen production technologies integrates basic and applied research, technology development and demonstration, and supporting activities. To adequately address the diverse range of technologies and feedstocks associated with hydrogen production, the office is closely coordinated with activities within the DOE Offices of Energy Efficiency and Renewable Energy (EERE), Nuclear Energy (NE), Fossil Energy (FE), and Science (SC). The U.S. Department of Transportation (DOT) also participates in activities involving codes and standards development,

¹ The energy content of a gallon of gasoline and a kilogram of hydrogen are approximately equal on a lower-heating-value basis; a kilogram of hydrogen is approximately equal to a gallon of gasoline equivalent (gge) on an energy-content basis.

² This cost range results in equivalent fuel cost per mile for a hydrogen fuel cell vehicle compared to gasoline hybrid vehicles in 2020. The full explanation and basis can be found in DOE Record 11007, which is available at www.hydrogen.energy.gov/program_records.html.

infrastructure safety, and hydrogen vehicle safety. The key DOE offices involved in hydrogen production R&D are shown in Table I.1.

Types of Technologies

Thermal Processes. Some thermal processes use the energy contained in resources such as natural gas, coal, or biomass to release hydrogen, which is part of their molecular structure. In other processes, heat is used in combination with closed chemical cycles to produce hydrogen from feedstocks such as water. These latter processes are known as “thermochemical” processes.

Table I.1. DOE Partners in Hydrogen Production R&D

Office	Role
FCT, EERE	Direct and Integrated Hydrogen Production R&D Activities
Commercial technology providing bridge to renewable hydrogen	Hydrogen from Natural Gas
FE	Gasification Technologies
NE and the following EERE offices/programs: Bioenergy Technologies Office, Fuel Cells Technologies Office, Geothermal Technologies Office, Solar Technologies Office, and Wind and Water Power Technologies Office	Hydrogen from Renewable Resources
SC	Basic Research

Thermal processes include reforming of natural gas, gasification of coal, gasification of biomass, reforming of renewable liquid fuels, and high-temperature water splitting.

Electrolytic Processes. Electrolytic processes use electricity to split water into hydrogen and oxygen. Hydrogen produced via electrolysis can potentially result in zero GHG emissions, depending on the source used to generate the electricity. The source of the required electricity — including its cost and efficiency, as well as emissions resulting from electricity generation — must be considered when evaluating the benefits of hydrogen production via electrolysis. The electrolysis pathways of greatest interest for large-scale hydrogen production use low- or zero-carbon sources of electricity (such as wind, solar, or nuclear power).

Photolytic Processes. Photolytic processes use light energy to split water into hydrogen and oxygen. These processes offer long-term potential for sustainable hydrogen production with low environmental impact. Two main categories are photobiological, in which the photosynthesis of certain algae or cyanobacteria are harnessed to do the water splitting, and photoelectrochemical, in which a special class of semiconductors absorb sunlight and use the light energy to separate water molecules into hydrogen and oxygen.

Biochemical Processes. Biochemical processes use biochemical or microbial methods to convert organic matter, generally biomass including waste products, into hydrogen. These processes offer mid- to long-term potential for sustainable hydrogen production with low environmental impact. The two main categories are fermentation and microbial electrolysis cells.

Production Scales and Locales

Hydrogen can be produced in small-, medium-, and larger-scale facilities. Small-scale (distributed) facilities would produce from <100 to 1,500 kilograms of hydrogen per day with the production site at the fueling stations. Medium-scale (also known as semi-central or city-gate) facilities would produce 1,500 to 50,000 kilograms per day on the outskirts of cities. The largest (central) facilities would produce more than 50,000 kilograms of hydrogen per day. Co-production facilities, which would combine the production of hydrogen, fuel, heat, and electric power, are also being explored.



Distributed Production. Distributed production of hydrogen is the most feasible approach for introducing hydrogen as an energy carrier in the near term. This approach requires less capital investment for the smaller capacity of hydrogen initially needed, and it does not require a substantial hydrogen transport and delivery infrastructure.

Two types of distributed hydrogen production technologies that show promise for near-term development are (1) reforming of natural gas or liquid fuels, including bio-derived liquids, such as bio-oil, and (2) water electrolysis. Small-scale natural gas reformers are commercially available, and this technology should be capable of meeting DOE's hydrogen production cost targets when fully deployed.

Research for distributed hydrogen production will focus on reforming technologies and catalysts for hydrogen from bio-derived liquids and on small-scale electrolyzers for splitting water. For electrolysis to be competitive, the cost of electricity used for this production process needs to be lower than typical commercial rates. The use of a renewable energy source for electricity generation presents the opportunity for electrolytic hydrogen production without carbon emissions.

Semi-Central/City-Gate Production. Hydrogen may be produced in semi-central facilities, which offer intermediate production capacity, typically on the outskirts of urban areas. These facilities provide some economies of scale and are relatively close to refueling sites, thus reducing the cost and infrastructure for hydrogen delivery. Several technologies are well suited to this scale of production, including wind- or solar-driven electrolysis, reforming of renewable bio-derived liquids, natural gas reforming, and photoelectrochemical and biological hydrogen production.

Central Production. Large-scale hydrogen production facilities will be needed in the long term to meet major increases in hydrogen fuel demand. DOE is pursuing central production of hydrogen to take advantage of economies of scale and improved management of GHG emissions through strategies such as carbon capture, utilization, and storage (CCUS). Central production also provides the capability to produce hydrogen from a variety of resources: fossil, nuclear, and renewable. Central production of hydrogen will require development of a robust hydrogen distribution and delivery infrastructure.



Seven Major Technology Pathways

This *Hydrogen Production Roadmap* addresses seven promising hydrogen production pathways. These pathways are summarized in Table I.2 and discussed in detail in separate chapters of the document.

Table I.2. Major Hydrogen Production Technology Pathways

Distributed Natural Gas Reforming	Natural gas reforming (i.e., steam methane reforming (SMR)) is employed on a large scale to produce much of the commercial and industrial hydrogen used today. This roadmap identifies the technical barriers in scaling this technology down to the distributed generation scale. Natural gas reforming via SMR is the most mature of the distributed technologies being considered and is already capable of achieving the DOE hydrogen cost targets. However, to fully commercialize small-scale hydrogen production by natural gas reforming, additional development will be needed in areas that DOE has not addressed, including system integration, optimization, and technology validation.
Bio-Derived Liquids Reforming	Reforming of ethanol and other bio-derived liquids is similar to natural gas reforming but presents several unique issues, such as catalyst and water requirements. This technology is suitable for application in distributed and semi-central production.
Coal and Biomass Gasification	Gasification technologies can use coal, biomass, or a mixture of the two as their feed streams. Co-gasification of coal and biomass helps to address both the carbon issues associated with coal and the cost and supply issues associated with biomass. Coal gasification is suitable for central production, and biomass gasification is suitable for both central and semi-central production.
Water Electrolysis	Water electrolysis uses existing water and electricity infrastructures to generate hydrogen on demand. In addition to near-term distributed generation, larger central production via wind power is being studied.
Thermochemical Production	High-temperature thermochemical water splitting is a technology in early development that holds the potential to produce only hydrogen and oxygen without accompanying greenhouse gas emissions. EERE is supporting the development of thermochemical cycles with the thermal energy supplied by solar power, while NE supports the development of nuclear-driven thermochemical cycles using waste heat from reactors.
Photoelectrochemical Production	Photoelectrochemical direct water splitting is similar to photovoltaics in that it uses a semiconductor material to collect the sun's energy. Instead of producing electrons, however, it produces hydrogen and oxygen. The technology requires long-term development and is suitable for semi-central and central hydrogen production.
Biological Production	Biological hydrogen production uses microorganisms to produce hydrogen. Four main pathways constitute biological hydrogen production: photolytic (direct water splitting), photofermentative (solar-aided organic decomposition), dark fermentative (organic decomposition), and microbial-aided electrolysis (microbial metabolism of organic molecules provides some of the power for electrolysis). The technology is suitable for semi-central and central hydrogen production.

Timeline, Feedstocks, and Energy Sources

With the exception of natural gas reforming, all hydrogen production technologies discussed in this roadmap require significant advancements and additional development prior to commercial use. While some sustainable technologies are further from commercial readiness than others, all of these production pathways have the potential to improve hydrogen availability and affordability while helping shift our reliance from foreign to domestic energy resources. In the 21st century, our nation will deploy a range of hydrogen production technologies as allowed by progress in R&D, infrastructure readiness, and demand. Some technologies will be cost-competitive for the transition period, while others are considered longer-term technologies.

Figure I.1 provides a broad overview of the general time frames in which these technologies are expected to move into commercial production. The feedstocks, energy sources, and production scale for each technology pathway influence market readiness.

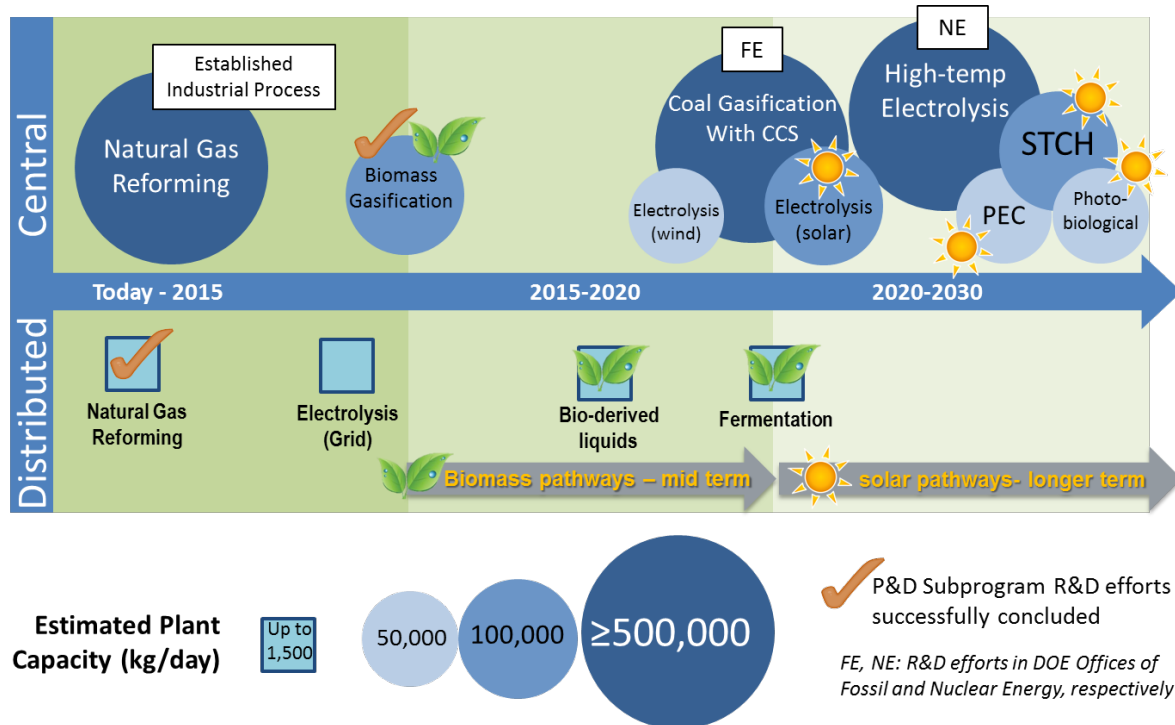

Figure I.1. Technology Pathway Development Timelines, Feedstocks, and Energy Sources for Hydrogen Production³

Key Roadmap Elements

Each chapter in this roadmap describes a technology pathway, the pathway’s current status and technical targets, the gaps and technical barriers associated with the pathway, and the strategies to overcome these barriers to realize the DOE hydrogen production threshold target of <\$2.00 gge.

DOE Threshold Cost

DOE has established a threshold cost goal of \$2.00 to \$4.00 per gge delivered, dispensed and untaxed for hydrogen fuel. An apportioned value of <\$2.00 per gge of hydrogen has been allocated for production costs.⁴ The hydrogen threshold cost is a DOE threshold cost and not a Partnership goal or target. DOE determined the methodology and other assumptions used to establish the threshold cost with input from multiple stakeholders, including the Partnership’s Hydrogen Production and Fuel Pathway Integration Technical Teams and others.⁵

³ Katie Randolph, “Overview of Hydrogen Production,” (presentation, DOE, May 16, 2013) http://www.hydrogen.energy.gov/annual_review13_proceedings.html.

⁴ Scott Weil, Sara Dillich, Fred Joseck, and Mark Ruth, “Hydrogen Production and Delivery Cost Apportionment,” DOE Hydrogen and Fuel Cells Program Record #12001 (Washington, DC: U.S. Department of Energy, 2012), http://www.hydrogen.energy.gov/pdfs/12001_h2_pd_cost_apportionment.pdf.

⁵ Fred Joseck and Mark Ruth, “Hydrogen Threshold Cost Calculation,” DOE Program Record (Offices of Fuel Cell Technologies) #11007 (Washington, DC: U.S. Department of Energy, 2011), http://hydrogen.energy.gov/pdfs/11007_h2_threshold_costs.pdf.

Currently, hydrogen can be produced from steam methane reforming, using commercially available technology, at a projected high-volume production cost of ≤\$2.00 per gge over a wide range of natural gas prices.⁶

DOE’s cost goals for hydrogen production are quantified in Table I.3 as the cost of produced and untaxed hydrogen. Delivery of hydrogen and forecourt compression, storage and dispensing are addressed in the Hydrogen Delivery Tech Team Roadmap.

Table I.3. DOE Hydrogen Production Cost Reduction Goals (\$/gge produced)⁷

Reduce the Cost of Hydrogen to <\$2.00 Produced and Untaxed. This Goal Is Independent of the Technology Pathway.	
By 2015 →	\$5.90/gge Distributed production of hydrogen from bio-derived renewable liquids
	\$3.90/gge Distributed production of hydrogen from water electrolysis
	\$3.00/gge Central production of hydrogen from water electrolysis using green electricity
	\$2.10/gge Central production of hydrogen from biomass gasification
	\$14.80/gge Central production of hydrogen from solar-driven high-temperature thermochemical water splitting
	\$17.30/gge Central production of hydrogen from solar-driven low-temperature photoelectrochemical water splitting
By 2020 →	\$2.30/gge Distributed production of hydrogen from bio-derived renewable liquids
	\$2.30/gge Distributed production of hydrogen from water electrolysis
	\$2.00/gge Central production of hydrogen from water electrolysis using green electricity
	\$2.00/gge Central production of hydrogen from biomass gasification
	\$3.70/gge Central production of hydrogen from solar-driven high-temperature thermochemical water splitting
	\$5.70/gge Central production of hydrogen from solar-driven low-temperature photoelectrochemical water splitting
	\$9.20/gge Central photolytic biological production of hydrogen

⁶ Sara Dillich, Todd Ramsden, and Marc Melaina, “Hydrogen Production Cost Using Low-Cost Natural Gas,” DOE Hydrogen and Fuel Cells Program Record #12024 (Washington, DC: U.S. Department of Energy, 2012), http://www.hydrogen.energy.gov/pdfs/12024_h2_production_cost_natural_gas.pdf.

⁷ Office of Energy Efficiency and Renewable Energy, *Fuel Cell Technologies Office Multi-Year Research, Development, and Demonstration Plan* (Washington, DC: U.S. Department of Energy, November 2012), Section 3.1, www1.eere.energy.gov/hydrogenandfuelcells/mypp/.

All of the cost and technology advances described in this roadmap must take place within the constraints of the regulatory environment, limited physical space, and other resource limitations.

Common Technology Barriers

Numerous technical barriers remain. Many are unique to one technology pathway, but several are cross-cutting. Each of the following chapters explores the barriers specific to a technology pathway and identifies the most critical technology gaps. Those barriers that are common to multiple production technologies are described here.

Hydrogen Quality

Hydrogen purity is a major issue for hydrogen destined for use in fuel cells on board vehicles. Platinum catalysts used in most vehicle fuel cells can be easily “poisoned” by some impurities in the hydrogen, ultimately rendering them ineffective. Therefore, hydrogen production technologies must either produce high-purity hydrogen directly or incorporate additional purification processes downstream.

Requirements for the quality of hydrogen to be used in fuel cell vehicles are becoming increasingly stringent.⁸ These stricter requirements represent a major hurdle for technology and production costs, and they add a further cost burden in the form of support and equipment for quality assurance. In addition, standard test methods are not readily available to detect some of the contaminant species at the prescribed level. Solutions for this issue continue to be a research priority.

Control and Safety

All hydrogen production technologies will be required to meet the strictest safety requirements. The permitting process relies on proven technology reliability and safety. Production units for placement at refueling stations, in particular, must be designed to operate with minimal manual assistance. This capability will use back-up and fail-safe modes, remote monitoring, and intermittent maintenance schedules.

Capital and Operating Costs

To offer a competitive energy alternative, hydrogen must be economically attractive to American consumers. Capital costs for many hydrogen production technologies today are too high for cost competitiveness. These costs should drop as developers apply the principles of design for manufacturing, identify better materials, and move into larger-scale manufacturing. Operating costs will similarly decline as equipment developers identify improved materials, consolidate processing steps, and enhance equipment performance and integration.

Community Acceptance Barriers

Technology advances require accompanying outreach efforts to encourage public acceptance of hydrogen fuel cell vehicles and hydrogen fueling stations. Community barriers that are shared by all production pathways include regulations, codes and standards, and education to assure wide public acceptance of hydrogen fuel.

Codes, Standards, and Regulations

Inspection, testing, certification, and permitting necessary to transfer new hydrogen production technologies into commercialization will require amending existing and creating new regulations, codes,

⁸ Office of Energy Efficiency and Renewable Energy, *Fuel Cell Technologies Office Multi-Year Research, Development and Deployment Plan* (Washington, DC: U.S. Department of Energy, 2012), Appendix C, www1.eere.energy.gov/hydrogenandfuelcells/mypp/.

and standards. This process will require extensive outreach to familiarize regulatory agencies with the technologies.

Regulations, codes, and standards have been in place for many years to address the public safety issues associated with large-scale centralized hydrogen production through natural gas reforming. However, compact reformers at hydrogen fueling stations represent a new application and product design.

Regulations, codes, and standards must be created or amended to cover all fabrication, inspection, testing, certification, and permitting prior to commercial adoption.

The regulations for hydrogen production from reforming of bio-derived liquids, electrolysis, and other technologies, and for hydrogen storage at the forecourt station will likely be derived from current natural gas reforming regulations. Issues relating to on-site feedstock storage, gas emissions, and waste (solid/liquid) storage and disposal will also need to be addressed. Some areas not effectively covered by current regulations, codes, and standards include the following:

- **Operations and Maintenance Plans.**

Equipment operations and maintenance (O&M) plans are dependent upon the standards set by individual companies. A minimum standard is needed.

- **Certification Testing.** Certification procedures and related costs vary widely among third-party certifiers. These disparities can lead to certification of less-than-optimal reformer designs that may not be ready for commercial use. Uniform testing with industry-recognized pass/fail criteria is needed.

- **On-Site Storage of Renewable Liquids.** Issues may arise regarding the storage of renewable feedstocks on site. Some feedstocks will be relatively benign (e.g., carbohydrates) and will likely require minimal regulation, while others may fit under the regulations now being developed for E85, E100, and bio-diesel. Standards for other types of feedstocks may need to be developed.

- **Permitting.** The permitting process varies from state to state and from municipality to municipality. State and perhaps even national standardization of the process should be encouraged.

- *Renewable liquid feedstock on-site storage permitting.* Ethanol is well received and the number of forecourt stations offering it is growing rapidly, so permitting for this bio-derived liquid process may be fairly simple. Permitting will need to be addressed for other bio-derived liquids being considered for hydrogen production.

- *Emissions.* Although some regulated gas emissions will still be generated by some near- and mid-term production technologies (notably reforming and gasification), emissions from hydrogen production are generally lower than for gasoline. For example, the nitrogen-containing fertilizer used to grow many feedstocks generates a relatively small amount of NO_x emissions, and the opening of storage tanks for refueling may release some volatile organic compounds (VOCs). Industrial experience in dealing with these types of emissions in other facilities can be applied to address them in hydrogen production processes.

- **Waste Storage and Disposal.** Depending upon the particular feedstock and reforming technology, hydrogen production processes may generate solid or liquid wastes. Examples can be found in the

Codes, Standards, and Regulations

The establishment and adoption of codes and standards is performed on a national level through code and standard development organizations and federal agencies. On the state level, state legislatures and various agencies determine which codes and standards will be adopted. Local Authorities Having Jurisdiction (AHJ), of which there are approximately 144,000 in the United States, can further increase the regulatory requirements through adoption of more stringent codes and standards than those adopted into state regulatory law. In addition, for permit approvals, local communities can provide input on whether a new technology should be installed and operated in or around their neighborhoods.

bio-derived liquid pathway section. Crude glycerol is an inexpensive feedstock containing salts that must be removed prior to steam reforming. The salt removal process may create wastes that require disposal. Similarly, aqueous-phase reforming of bio-derived liquids may produce some liquid organic and/or inorganic wastes that require disposal. If the wastes are non-toxic, conventional disposal methods (garbage, sewer, etc.) may be used (assuming proper permits) to minimize or negate any on-site storage issues. However, if conventional disposal methods are not an option, then the waste material will need to be stored and disposed of using more costly industrial waste methods. These costs will need to be included in the models and analyses. Permits may be required for on-site waste storage and disposal, depending on the type of reforming used and the wastes produced. For steam reforming, the contaminant removal step is likely to generate a small waste stream — comparable to that of sulfur in natural gas reforming. Aqueous phase reforming may create a larger waste stream; however, this technology remains in a relatively early stage of development, so the significance of this issue is difficult to determine. Industry has a great deal of experience in addressing waste storage and disposal, and that experience can be applied to these issues for hydrogen production.

- **Insurance Risk Mitigation.** Lack of an extensive historical database documenting field reliability, performance, durability, and safety issues hinders risk assessment by insurers. This could limit broad establishment of insurance coverage for hydrogen fueling stations and/or lead to high rates. A national insurance pool may be needed for partial coverage of deductibles and to limit liability.

Further information on the codes, standards and regulations associated with hydrogen can be found in the Codes and Standards Tech Team Roadmap.

Community Education and Outreach

Increased public understanding is needed to facilitate acceptance and adoption of hydrogen fuel cell vehicles and ease the permitting of hydrogen fueling stations. The production of hydrogen for commercial sale will involve national and state regulators, standard and code-writing bodies, local officials, permitting authorities, emergency responders, and local communities. All of these stakeholders must be educated about the technology and applicable regulations, codes, and standards.

As a first step, DOE and other municipalities are supporting demonstration projects that give a limited number of communities an opportunity to gain first-hand experience with hydrogen fuel cell vehicles and associated hydrogen fueling stations. Providing accurate and timely information on an ongoing basis is also of paramount importance. Selected information about hydrogen and fuel cells is available on the DOE website.⁹

Critical Technology Needs

Collectively, the critical R&D activities for each technology pathway described in this roadmap make up the hydrogen production R&D program. The technologies are in different stages of development, and each offers unique opportunities, benefits, and challenges. Economics favor certain technologies over others in the near term, but as the technologies mature and market drivers shift, a broad range of technologies is expected to become economically viable and take advantage of the range of energy and feedstock resources available in each region.

Each of the technology-specific chapters identifies the critical technology gaps for the specific production technology under discussion. Determination of critical technology need is based on consideration of the core barriers as well as the outlook for achieving technical targets. DOE has established and periodically

⁹ Office of Energy Efficiency and Renewable Energy, “Fuel Cell Technologies Office,” U.S. Department of Energy, <http://www1.eere.energy.gov/hydrogenandfuelcells/>.

updates clear technical targets for each hydrogen production technology and applicable feedstock.¹⁰ These targets and associated timelines reflect the expected capacity of a production unit, the current stage of technology development, the costs and characteristics of the feedstock, and other factors.

Path Forward

For hydrogen to become a major energy carrier, consumers will need to see that hydrogen and the vehicle power systems in which it is used are cost-competitive with other options on the market. For light-duty vehicles, the cost per mile to the consumer must be roughly the same as for conventional fuels in internal combustion engine (ICE) or hybrid vehicles.

DOE periodically revises the threshold cost goal to reflect projected fuel costs and the evolving energy efficiencies of vehicle power systems on a cost-per-mile basis. The DOE goal for all seven technologies under development is to produce hydrogen that can be dispensed to vehicles at a cost competitive with other options. Current priorities for R&D and supporting activities in these seven major hydrogen production technology pathways are summarized in Table I.4.

Table I.4. Pathways Forward

Production Technologies	R&D Priorities
Distributed Natural Gas Reforming	Pre-competitive technical and cost challenges have been sufficiently addressed for steam methane reforming so that industry may complete technical development without additional DOE resources
Bio-derived Liquids Reforming	Catalyst development, capital cost reduction, and affordable feedstocks
Coal and Biomass Gasification	Capital cost reduction, carbon capture and storage, and greater flexibility for use of renewable biomass feedstock
Water Electrolysis	Capital cost reduction, higher efficiency, and materials development
Thermochemical Hydrogen	Chemical cycle selection and materials development for improved kinetics and durability, reactor design and development for high solar to hydrogen efficiency
Photoelectrochemical	Identification and development of optimal materials, integrated devices, and reactor configurations
Biological	Biological candidate identification and genetic engineering to increase hydrogen production efficiency

¹⁰ Office of Energy Efficiency and Renewable Energy, *Fuel Cell Technologies Office Multi-Year Research, Development, and Demonstration Plan* (Washington, DC: U.S. Department of Energy, November 2012), Section 3.1, www1.eere.energy.gov/hydrogenandfuelcells/mypp/.

1.0 Distributed Natural Gas Reforming

The distributed natural gas reforming (DNGR) pathway calls for producing hydrogen in distributed facilities via steam reforming of natural gas. This process is most commonly employed in semi-central and central facilities to produce much of the commercial and industrial hydrogen used today. Small-scale modular units have been developed which can be configured to achieve the desired scale of distributed production.

1.1 Current Technical Status and Technical Targets

Analysis of distributed natural gas reforming indicates that federal R&D partnerships have addressed the major technical and cost challenges to the extent that private industry should be able to tackle the remaining technical and cost barriers and complete the commercial development of this production technology without additional DOE resources. Barriers discussed herein remain for industry to resolve in commercialization.

DNGR offers the most economical and technically viable near-term approach to hydrogen (H₂) supply and infrastructure. Early availability is key to promoting acceptance of hydrogen fuels and creating the market demand that will drive future R&D of more sustainable hydrogen production technologies. As this technology would ultimately increase demand for natural gas, it is viewed as a stepping stone to the future rather than a long-term solution. Mid- and longer-term hydrogen production technologies will use low- or zero-carbon domestic feedstock and renewable energy sources.

The most common reforming process for natural gas consists of two sequential processes: steam–methane reforming followed by a water–gas–shift (WGS) reaction. Simplified reactions of these processes are:¹¹



The main deactivation mechanism for hydrocarbon reforming is coke (carbon) formation. The following are simplified reactions for coke formation:^{12,11}

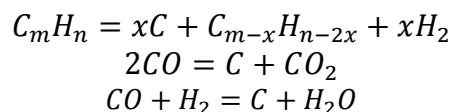

The most common way to eliminate coking is to increase the steam-to-carbon ratio, or more simply put, the amount of water in the feed stream. Therefore, most methane steam reforming techniques use steam-to-carbon molar ratios in the range of 1.7-4.0.¹³

Distributed Natural Gas Reforming

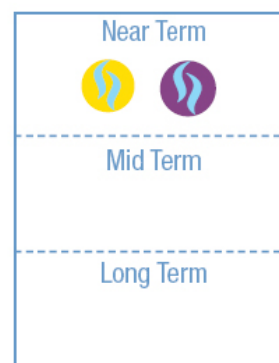

Feedstock:	Natural gas
Energy Source:	Natural Gas
Production:	Distributed

Environmental Benefits

Although greenhouse gas emissions from distributed natural gas reforming are already lower than for gasoline use, R&D should reduce them further by increasing the efficiency of feedstock conversion to hydrogen.

¹¹ J. D. Holladay, Y. Wang, and E. Jones, “Review of Developments in Portable Hydrogen Production Using Microreactor Technology,” *Chemical Reviews* 104 (2004): 4767–4789.

¹² Ibid.

¹³ J. R. Rostrup-Nielsen, “Steam Reforming,” in *Handbook of Heterogeneous Catalysis*, 2nd ed., vol. 6, eds. G. Ertl, et al. (Weinheim, Germany: Wiley-VCH, 2008), 2882–2905.

Cost Projections

Hydrogen produced from the DNGR process based on existing steam–methane reforming processes can be cost-competitive with gasoline. Projections (see Table 1.1) based on high-volume production (i.e., assumptions of 1,500 kg/day production and of economies of scale in manufacturing of reformers and balance of plant) indicate that reforming natural gas at the fueling station can produce hydrogen for a cost of close to \$2.00/gge.¹⁴ Even lower costs are predicted for natural gas prices less than ~\$5/MMBtu (million British thermal units).¹⁵ As a result, DOE is no longer funding R&D in natural gas reforming for FCEV fueling, although it is anticipated that industry will continue to make incremental improvements to steam methane reforming technology.

Table 1.1. Distributed Natural Gas Reforming — Cost Projections

Projection Year	Production Scale	Cost/gge (production)	Cost/gge (dispensed)
2011	Distributed	\$2.00	\$4.50
2015	Distributed	\$2.10	\$3.80

1.2 Gaps and Technical Barriers

DOE’s previous research activities were strategically directed at overcoming specific barriers identified in earlier versions of the FCT Office’s *Multi-Year Research, Development, and Demonstration Plan* (MYRD&D),¹⁶ as well as other barriers identified by the U.S. DRIVE Partnership’s HPTT. These barriers are listed in Table 1.2 and described more fully below.

Reformer Capital Costs

Capital costs are high due to the lack of economies of scale in manufacturing with hardware often customized and not produced in large quantities, and balance-of-plant (BOP) components too expensive and not sufficiently durable.

Reformer Manufacturing

This barrier was partially addressed by the R&D funded by DOE. Manufacturing considerations were sufficiently resolved so that industry can, without DOE’s support, overcome remaining manufacturing issues, which primarily involve scaling manufacturing processes. Distributed reformer units are currently designed and built one at a time, so the capital cost for each is high and the units are typically not optimized for size. This limited manufacturing approach increases the cost of equipment manufacturing and installation. Moreover, the low durability and relatively short service life of BOP keep capital costs above economically feasible levels. However, as the number of units manufactured per year increases, it is projected that the fabrication costs will decrease.

¹⁴ Office of Energy Efficiency and Renewable Energy, *Fuel Cell Technologies Office Multi-Year Research, Development, and Demonstration Plan* (Washington, DC: U.S. Department of Energy, November 2012), Section 3.1, www1.eere.energy.gov/hydrogenandfuelcells/myrpd/; U.S. Department of Energy Hydrogen and Fuel Cells Program, “Current Distributed Hydrogen Production from Natural Gas without CO₂ Sequestration, version 3.0,” http://www.hydrogen.energy.gov/h2a_prod_studies.html.

¹⁵ Sara Dillich, Todd Ramsden, and Marc Melaina, “Hydrogen Production Cost Using Low-Cost Natural Gas,” *DOE Hydrogen and Fuel Cells Program Record* (Washington, DC: U.S. Department of Energy, 2012), http://www.hydrogen.energy.gov/pdfs/12024_h2_production_cost_natural_gas.pdf.

¹⁶ Office of Energy Efficiency and Renewable Energy, *Fuel Cell Technologies Office Multi-Year Research, Development, and Demonstration Plan* (Washington, DC: U.S. Department of Energy, November 2012), Section 3.1, www1.eere.energy.gov/hydrogenandfuelcells/myrpd/.

Table 1.2. Distributed Natural Gas Reforming — Summary of Barriers

Reformer Capital Costs	Current small-scale distributed natural gas and renewable liquid feedstock reforming technologies have capital costs that are too high to achieve the targeted hydrogen production cost.
Reformer Manufacturing	Distributed reforming units are currently designed and built one at a time. These custom units tend to be prohibitively large and expensive.
Station Footprint	To be economically feasible in urban settings, the physical footprint of stations needs to be reduced.
Operations and Maintenance	O&M costs for distributed hydrogen production from reforming natural gas and renewable feedstocks are too high. Current systems require excessive maintenance and in-person monitoring. Finally, there is currently no simple, low-cost way to ensure that the hydrogen meets the high quality standards necessary for proper fuel cell operation (as discussed in the Introduction).
Reliability	The BOP reliability needs improvement. The on-off cycling of the DNCR results in decreased reformer catalyst life. (The sulfur, added as an odorant to natural gas, is removed prior to reforming in order to extend catalyst life. Desulfurizer life remains an issue.)
Control and Safety	Process control, safety and environment monitoring protocols are essential for successful deployment and public acceptance of DNCR sites. DNCR sites will need reliable hydrogen control to assure public safety and address environmental issues without escalating costs. Specifically, controls are needed to match demand profiles, avoid hydrogen leakage, and minimize emissions.

Station Footprint

The specific location of a DNCR station determines the constraints on the station footprint. Refueling stations providing an average 1,500 gge per day of hydrogen will tend to occupy a relatively large footprint owing to the size and amount of process equipment involved. Reformer and BOP size reduction may be needed to decrease this footprint and enable wider adoption of distributed generation technologies.

Operations and Maintenance Costs

Multiple barriers will need to be addressed to minimize O&M costs for producing hydrogen via distributed reforming of natural gas. These O&M issues are similar to the issues facing commercial hydrogen production in larger plants, and it is believed they can be overcome by the industry in applying lessons learned from their larger counterparts. Cost performance must be benchmarked versus conventional fueling stations. Moreover, all system components must be considered in O&M cost projections, including feed pre-conditioning (e.g., sulfur removal), reforming, controls, process utilities, quality assurance and control (QA/QC) (e.g., sensors), compression, storage, dispensing, and safety.

Durability. Both the frequency and cost of repairs for the fuel processor system and BOP must be considered. Down time also has an impact on co-located businesses (e.g., convenience stores), which may account for a significant portion of site profits.

Scheduled Maintenance. Cost prohibits full-time, on-site maintenance staff, so routine maintenance will need to be minimized and system troubleshooting will need to be automated or monitored remotely.

Demand Management. Hourly and daily variations in demand must be handled in a way that is transparent to the customer and the on-site fueling station staff. Design and operational decisions to

address demand variability will impact O&M as well as capital costs (e.g., turn-down, periodic shut-down and restart).

Desulfurization. A variety of sulfur-containing odorants are used in natural gas to facilitate easy detection in case of a leak. This sulfur must be removed prior to reforming to protect reformer catalysts from deactivation; sulfur in the dispensed hydrogen can also lead to serious fuel cell damage. Sulfur removal devices may require routine maintenance (e.g., replacement of adsorbents). Both the maintenance and disposal operations must be appropriately designed for safety.

Other O&M Costs. Other O&M costs must also be lowered wherever possible by minimizing the number of system components, the amount of material required, and energy losses. The technology also suffers from the high costs of separation and purification technologies, costs of meeting quality standards (1-5 cents/kg) and fuel quality verification (2-10 cents/kg),¹⁷ BOP components, replacement and disposal of used materials (catalysts, sorbents), and limited system reliability and lifespan.

Feedstock Issues

The chemical composition of natural gas is not constant and may vary considerably, depending on the source of the gas and pretreatment prior to delivery. Typically, natural gas is composed primarily of methane. However, the concentration of methane can range from approximately 70% by volume to a theoretical value of 100%.¹⁸ Such wide variation in composition could affect performance and the stability of the catalytic reformer.

In addition to odorant additives and known catalyst poisons such as sulfur compounds, natural gas can include a variety of other chemical compounds — sometimes in relatively high concentration. Depending on the source of the gas, inorganic impurities such as nitrogen, oxygen, carbon dioxide, and water may be present. Inert materials such as nitrogen may have been added to adjust the energy content of the gas. In general, most of these inorganic compounds would be fairly unreactive; however, their presence needs to be considered when selecting a reformer design and catalyst.¹⁹

Control and Safety

Control and safety issues associated with natural gas reforming include integrating system components, optimizing start-up and shut-down processes, improving turn-down capability, responding to feedstock variability, and enabling rapid on-off cycling. The control system costs remain high and need to be further reduced through system simplification and/or reduced sensor count. The sensors should be more cost-effective and reliable compared to currently available technology. The permitting process critically relies on the proven reliability and safety of these units in the forecourt environment, which will be a key qualification target. These units must be designed to operate in an environment of minimal manual assistance, which will require attributes such as a back-up fail-safe mode, remote monitoring, and sparse maintenance schedules. The system design should ensure that any effluents (such as sulfur dioxide [SO₂] and other gas and liquid exhausts) meet all requirements for local and national permitting processes.

¹⁷ S. Ahmed, F. Joseck, and D. D. Papadias, “Hydrogen Quality for fuel cell vehicles — A modeling study of the sensitivity of impurity content in hydrogen to the process variables in the SMR-PSA pathway,” *International Journal of Hydrogen Energy* 34 (2009): 6021–6035.

¹⁸ Natural Gas Supply Association, “Background: NaturalGas.org,” <http://www.naturalgas.org/overview/background.asp>.

¹⁹ M. Foss, *Interstate Natural Gas, Quality, Specifications and Interchangeability* (Sugar Land, Texas: Center for Energy Economics, 2004), http://www.beg.utexas.edu/energyecon/lng/documents/CEE_Interstate_Natural_Gas_Quality_Specifications_and_Interchangeability.pdf.

1.3 Strategy to Overcome Barriers and Achieve Technical Targets

The critical technology needs for DNGR address the various barriers previously discussed. Certain technology needs may address multiple barriers at once. Table 1.3 lists the critical technology needs for producing hydrogen through DNGR. Discussion of these efforts follows the table.

Table 1.3. Distributed Natural Gas Reforming — Critical Technology Needs

Reduce Capital Costs	<ul style="list-style-type: none"> → Improve catalysts → Improve separations and purification technologies → Integrate system components; develop one-step reforming/shift → Optimize system turn-down capability to manage variable demand → DFMA/high-volume equipment manufacturing and BOP optimization
Reduce O&M Costs	<ul style="list-style-type: none"> → Automate process control → Improve equipment reliability → Improve reliability under on-off cycle conditions → Minimize gas and energy losses → Capital utilization

Reduce Reformer Capital Costs

Equipment capital costs are a significant factor in hydrogen production costs using DNGR technology. Some efforts are needed to overcome the technical barriers associated with process intensification, since combining process steps will lower capital costs by reducing the part count for process equipment (e.g., combining the shift reaction and hydrogen separation processes into a single step). Additional efforts will be required to implement a design for manufacturing that facilitates mass production of equipment and development of materials that are lower-cost, easier to manufacture, and more durable. Modular components with repeat units suited for mass manufacturing will enable economy of scale and allow for greater variability in plant capacity.

Improve Catalysts. Large-scale steam methane reformers (SMRs) typically use a low-activity nickel-based catalyst. Although inexpensive, the nickel-based catalysts are prone to coking, and owing to their low activity, the reactors must be relatively large.²⁰ Most DNGR applications tend to use a precious metal-based catalyst.²¹ Some precious metal catalysts have a higher activity and are less prone to coking; however, their cost is higher. Lower-cost catalysts are needed that can provide high steam reforming activity while remaining non-selective for various undesired side reactions, such as methanation, dehydration, dehydrogenation, coking, and reverse WGS reaction. The resultant high yields will help increase the energy efficiency of production.

Improve Separations. Process intensification is a key strategy for reducing the capital cost of distributed hydrogen production from steam methane reforming. For example, development of improved membranes for separating hydrogen from other gases during the reforming/shift reactions could contribute to the success of process intensification for SMRs.

Improve Feedstock Pre-Treatment. Typically, reforming catalysts require odorant-free natural gas and de-ionized water. Feedstock pretreatment systems that achieve these conditions can represent a significant

²⁰ J. D. Holladay, K. Hu, D. L. King, and Y. Wang, “An Overview of Hydrogen Production Technologies,” *Catalyst Today* 139 (2009): 244–260.

²¹ U.S. Department of Energy, *2011 NREL/DOE Hydrogen and Fuel Cell Manufacturing R&D Workshop Report* (Washington, DC: U.S. Department of Energy, 2011), http://www1.eere.energy.gov/hydrogenandfuelcells/pdfs/mfg2011_wkshp_report.pdf.

share of the capital, operating, and maintenance costs. Several approaches can reduce the costs associated with these systems. Sulfur can be removed from pipeline natural gas by employing such processes as direct physical adsorption and selective oxidation, along with optional hydro-desulfurization to change sulfur species to more readily absorbable hydrogen sulfide (H₂S). Since the types of odorants in pipeline natural gas are location-specific, a one-size-fits-all design for sulfur removal is not feasible. Each process has unique advantages and disadvantages. Adsorption poses a disposal problem for the spent adsorbents and the sulfur, while selective oxidation negatively affects system efficiency. Sulfur-tolerant catalysts are therefore ideal. However, these catalysts are likely to be more costly, and all options must be considered to balance cost and functionality.

Optimize System to Manage Variable Demand. Demand for hydrogen refueling will vary significantly over the course of a day. This demand variability may be handled through a combination of on-site hydrogen storage and load-responsive capability in the reformer. The extent to which each of these two strategies is used to handle demand variability will have a significant impact on capital costs and the station footprint. Sizing the reformer to handle peak demand will increase capital costs for the reformer, whereas increasing storage will increase the system footprint to accommodate storage tanks. Optimizing this balance also requires considering the relative impacts on maintenance costs and safety. Prospective station owners need a model or tool that can be readily calibrated with local data and projections to suggest a feasible balance between storage and load-responsive capability for a specific station.

DFMA/High-Volume Equipment Manufacturing and BOP Optimization. DFMA will be a key component of cost reduction efforts for distributed reformer units, both for near-term, semi-custom installations and for longer-term, higher-volume manufacturing. In the near term, in light of limited production volumes, DFMA should focus on developing reformer designs that incorporate commonly available (commodity) materials and use common tooling and standard sizing for procured components (e.g., tubing, heat exchanger, and reactor components). Design for modularity will be especially important for semi-custom installations. Modular design will allow incorporation of improvements in specific subsystems without redesigning the entire process. Flexible modular design will also allow scalable systems, increasing the application domain and overall production volumes.

For widespread deployment, on-site reformers will be manufactured in large quantities (hundreds of systems per year), and the goals for DFMA will shift toward incorporating optimal high-volume production methods. Research efforts in DFMA for higher-volume manufacturing should focus on three critical aspects of the design and manufacturing process: 1) optimal design of subsystems to reduce size/part-count and enhance maintainability, 2) substitution of less costly materials and reduction of the total amount of material (e.g., catalyst) used, and 3) integration of whole system design (including compression, storage, and dispensing) to reduce the costs of installation and operation.

Optimization of subsystem design will consider several aspects of manufacturing and operation including:

- Design for serviceability, allowing for operable connections between subsystems and consideration of the service schedules for different components.
- Tuning of reaction conditions and flow rate design to optimize overall plant equipment needs for the targeted application.

Significant savings could be realized through the use of less costly materials, especially the substitution of iron-based alloys for the super nickel alloys currently used in steam service, condensers, and heat exchangers. However, R&D is needed to produce new tooling, dies, and optimized manufacturing

techniques. Manufacturing and construction techniques that minimize the amount of material used will provide significant savings.²²

BOP components also constitute a significant part of the capital cost. Improved low-cost sensors, pumps, blowers, and monitoring equipment need to be developed. The BOP costs can be further reduced by developing common, interchangeable components, automated joining processes, and low-cost stamping and extrusion methods that permit high-volume assembly-line production of critical components that are currently machined and welded. Recommendations from a recent manufacturing workshop²³ include the need to develop manufacturing processes for hydrogen compressors, in-line sensors, and larger tubes for compressed gas storage.

Reduce Operating and Maintenance Costs

Costs for O&M also have a significant impact on the overall cost for producing hydrogen. Improvements in process design that increase energy efficiency and/or allow for greater variability and higher levels of contaminants in feedstocks will reduce O&M costs. O&M costs will also be reduced by improving process controls for cycle optimization, including the development of better and less expensive sensors and better turn-down capability. Development of low-cost sensors will reduce control costs and potentially reduce maintenance costs.

Automated Process Control. On-site labor should be reduced through the use of automated process control and remote monitoring, including automatic fault detection.

Increased Equipment Reliability. The reliability of BOP equipment with moving parts (such as pumps, compressors, and blowers) is often a limiting factor in overall system reliability. Increasing the reliability of these components along with minimizing equipment complexity is critical for improving system reliability. For reformer systems, sustained catalyst activity is also essential to reliable and efficient operation. Impurities in feedstocks (e.g., natural gas and water) must be controlled to protect reactor components. Monitoring techniques for inert components in the feed stream (nitrogen, water, etc.) will need to be implemented.

Minimize Gas and Energy Losses. Leaks of natural gas or hydrogen must be virtually eliminated to ensure safety, minimize loss of process efficiency, and minimize GHG emissions. Heat loss and heat rejection must also be minimized through well-designed insulation and heat integration.

Capital Utilization. Peaks and valleys in hydrogen demand for transportation must be leveled to maximize the utilization of capital. Reformer size must be balanced with an appropriate hydrogen storage system. Utilization may also be increased by finding alternate uses for the hydrogen or generating revenue from co-produced products. A distributed natural gas reformer has the potential to co-produce a variety of products in addition to hydrogen, such as heat, electricity, and steam. Local use or sale of these products can either increase site revenue or help to load-level reformer operation.

Water Purity. Natural gas steam reforming requires water to generate the steam. It is unclear how the presence of inorganic compounds in water may affect catalyst performance. Heavy metals tend to cause scaling/fouling problems to a system's internal piping and heat exchangers. At the very least, chlorine must be removed from municipal water because it is detrimental to the catalysts and all metals with which

²² Personal communication with F. Lomax, Chief Technology Officer, H2Gen Innovations, Inc., Alexandria, VA, August 9, 2007.

²³ U.S. Department of Energy, *2011 NREL/DOE Hydrogen and Fuel Cell Manufacturing R&D Workshop Report*, (Washington, DC: U.S. Department of Energy, 2011), http://www1.eere.energy.gov/hydrogenandfuelcells/pdfs/mfg2011_wkshp_report.pdf.

it comes into contact in the reforming system. Clearly, some level of purity is required for the reformer's feed water. However, the feed water need not be as low in resistivity as fuel-cell-grade cooling water (less than $5 \text{ microS}\cdot\text{cm}^{-1}$). If the standard for required purity can be relaxed without adversely affecting the performance of the reforming systems, the cost and complexity of feed water treatment systems could be greatly reduced.

2.0 Bio-derived Liquids Reforming

The bio-derived liquids reforming pathway calls for hydrogen production in distributed or semi-central facilities via gas-phase or aqueous-phase reforming of bio-liquids such as sugars, cellulose slurries, ethanol, or bio-oils. Bio-liquid reforming is similar to natural gas reforming but is usually challenged by limited catalyst activity and durability. Cost of the feedstock²⁴ hinders the cost-effective generation of hydrogen from bio-liquids, while availability and compositional non-uniformity pose difficulties in plant operations.²⁵

2.1 Current Status and Technical Targets

Distributed hydrogen production technologies based on bio-derived liquid reforming may afford viable renewable hydrogen pathways as a result of relatively low feedstock delivery and capital costs compared to other renewable hydrogen technologies. Currently, the capital cost of small-scale distributed reformers for biomass-derived liquid feedstock is too high to achieve DOE hydrogen production cost targets. Processing facilities will be able to take advantage of the latest and most efficient technologies as well as many of the lessons learned by the petroleum industry. Reformers can be scaled for distributed or semi-central hydrogen production, depending on the feedstock. For example, ethanol can be supplied to a semi-central reformer from several smaller plants.

Biomass is an abundant domestic renewable resource, enabling decreased dependency on foreign oil and increased energy and economic security.²⁶ It is anticipated that the potential for this pathway to meet the DOE threshold cost goal (\$2.00-\$4.00/gge high-volume production, delivered and dispensed) will be determined by 2020.

A wide range of biomass materials can be reformed to hydrogen. For bio-derived liquids, four main reforming technologies are used: steam reforming, partial oxidation autothermal reforming, and aqueous phase reforming.²⁷ Steam reforming is typically the preferred process for hydrogen production in industry. Similar to natural gas steam reforming, the bio-derived liquid steam reforming process produces syngas ($H_2 + CO$). Excess water is fed into the reformer to limit coking, which can lead to catalyst deactivation. The steam reforming reaction is strongly endothermic:²⁸

Bio-Derived Liquid Reforming

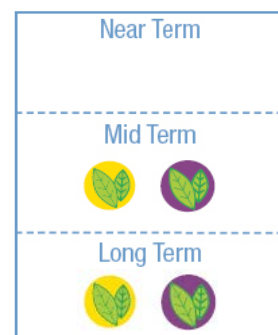

Feedstock:	Biomass
Energy Source:	Biomass
Production:	Distributed Semi-Central

Environmental Benefits

On a well-to-wheels basis, hydrogen production from renewable liquid feedstocks has significantly lower greenhouse gas emissions than hydrogen production from natural gas or petroleum. Efforts are being made to further reduce these emissions.

²⁴ National Research Council of the National Academies, *Review of the Research Program of the FreedomCar and Fuel Partnership*, Third Report (Washington, DC: The National Academies Press, 2010), http://www.nap.edu/openbook.php?record_id=12939&page=R1.

²⁵ T. P. Vispute and G. Huber, "Production of Hydrogen, Alkanes and Polyols by Aqueous Phase Processing of Wood-Derived Pyrolysis Oils," *Green Chemistry* 11 (2009): 1433–1445.

²⁶ Oak Ridge National Laboratory, *U.S. Billion-Ton Update: Biomass Supply for a Bioenergy and Bioproducts Industry* (Washington, DC: U.S. Department of Energy, August 2011), www1.eere.energy.gov/biomass/pdfs/billion_ton_update.pdf.

²⁷ J. D. Holladay, K. Hu, D. L. King, and Y. Wang, "An Overview of Hydrogen Production Technologies," *Catalyst Today* 139 (2009): 244–260.

²⁸ Ibid.

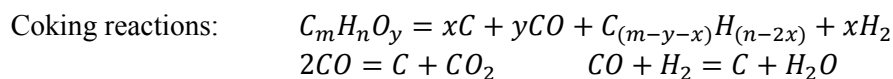
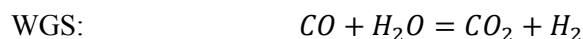
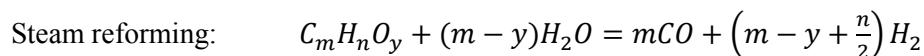

Partial oxidation (POX) converts hydrocarbons to syngas by partially reacting (combusting) the hydrocarbon with oxygen in an exothermic reaction. The major advantage of POX is that it does not require a catalyst, and therefore the POX reactor is not susceptible to catalyst poisoning that is encountered in other catalytic reformers (e.g., steam and autothermal). The challenges for POX include high reaction temperatures which require more expensive reactor construction materials, some soot formation, and a low H₂/CO ratio (1:1 to 2:1). As with the steam reforming process, a WGS reaction is required to increase the hydrogen content. The generalized POX reaction is:²⁹

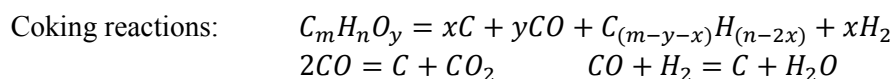
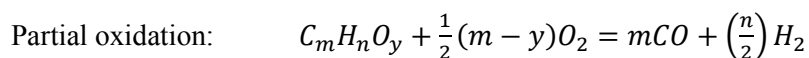

Autothermal reforming (ATR) combines steam reforming with partial oxidation. POX provides the heat for the endothermic steam reforming process, in theory, resulting in a thermally neutral process. Since the heat for the steam reforming is provided by the exothermic POX reaction, an external heat source for the reactor is not required. However, POX and ATR both need either an expensive and complex oxygen separation unit in order to feed pure oxygen to the reactor or a larger hydrogen purification system to handle a product gas diluted with nitrogen. Since a large amount of carbon monoxide (CO) is produced, a WGS reactor is required to maximize the hydrogen production. The generalized reaction equations for an ATR can be written as:³⁰

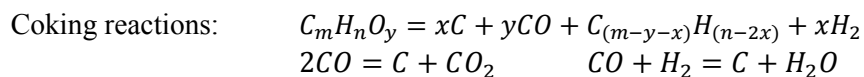
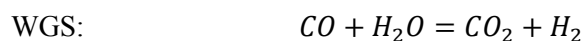
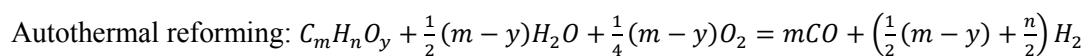

Aqueous phase reforming (APR) is a variation of steam reforming in which the biomass or bio-derived liquid is converted directly to hydrogen. For aqueous phase reforming, water soluble organics are decomposed at high pressure (~300 pounds per square inch [psi]) and relatively low temperatures (<300°C) to hydrogen. The high pressure keeps the components in the liquid phase, and the relatively low temperatures favor carbon dioxide formation over carbon monoxide, thus maximizing the hydrogen yield

²⁹ Ibid.

³⁰ J. D. Holladay, K. Hu, D. L. King, and Y. Wang, "An Overview of Hydrogen Production Technologies," *Catalyst Today* 139 (2009): 244–260.

without the need of a WGS reactor. As APR is still in developmental stages,³¹ researchers and developers are trying to address some of the issues related to catalysts and process development.

DOE Cost Targets

R&D on bio-derived liquids is focused on achieving the DOE cost targets for hydrogen production, as illustrated in Table 2.1. A large decrease in hydrogen cost was projected for 2020 based on assumptions that efficiency and equipment capital cost targets are met, and that feedstock costs drop significantly (>60%).³²

Table 2.1. Distributed Forecourt Production of Hydrogen from High-Temperature Ethanol Reforming — DOE Cost Targets³³

Target Year	Cost/gge (produced)	Cost/gge (produced & dispensed)
2011 Status	\$6.60	\$9.10
2015 Target	\$5.90	\$7.70
2020 Target	\$2.30	\$4.00

2.2 Gaps and Technical Barriers

Driving DOE's research activities are specific barriers identified in the MYRD&D,³⁴ as well as others identified by the U.S. DRIVE Partnership's HPTT. These are summarized in Table 2.2 and described more fully below.

Reformer Capital Costs

Currently, the capital cost of small-scale distributed reformers for biomass-derived liquid feedstock is too high to achieve target hydrogen production costs. High capital costs are caused by high catalyst costs, low conversion efficiencies, and multiple complicated unit operations that require many process steps in converting bio-derived liquids to hydrogen. Additionally, installation costs are too high, while components have insufficient reliability, durability and life span. The reformer and WGS unit operations require large amounts of catalysts and considerable maintenance. Commercial catalysts are designed for continuous use, whereas in distributed production, the reactors are turned on and off almost daily, causing thermal cycling that may degrade catalyst performance. Therefore, long-life, inexpensive, durable catalysts are needed. The most developed reformers operate at high temperatures (>700°C), requiring more expensive construction materials. Lower-temperature reactors are under development but have issues with coking. Either lower-cost materials for high-temperature operation are needed, or the lower-temperature reactors need to be improved. Finally, the high purity of hydrogen required for fuel cells puts upward pressure on capital costs by requiring expensive metal membranes or multiple pressure swing adsorption units. Considerable R&D is needed in this area.

³¹ A. Tanksale et al., "A Review of Catalytic Hydrogen Production Processes from Biomass," *Renewable and Sustainable Energy Reviews* 14 (2010): 166–182.

³² Office of Energy Efficiency and Renewable Energy, *Fuel Cell Technologies Office Multi-Year Research, Development, and Demonstration Plan* (Washington, DC: U.S. Department of Energy, November 2012), Section 3.1, www1.eere.energy.gov/hydrogenandfuelcells/myrpp/.

³³ Ibid.

³⁴ Ibid.

Reformer Manufacturing

Distributed reformer units are currently designed and built one at a time. The capital cost contribution to total hydrogen production cost is higher for smaller hydrogen production facilities designed for distributed applications. This limited manufacturing approach results in expensive system components with poor life span and durability, as well as increased BOP component cost. Finally, current systems are too large and too expensive, in part because of the need for site-specific fabrication of subsystems.

Station Footprint

The specific location of a distributed or semi-central liquids reforming station determines the constraints on the station footprint. Refueling stations providing an average 1,500 gge per day of hydrogen will tend to occupy a relatively large footprint because of the size and amount of process equipment involved.

Reformer and BOP size reduction may be needed to decrease this footprint and enable wider adoption of distributed generation technologies.

Table 2.2. Bio-derived Liquids Reforming — Summary of Barriers

Reformer Capital Costs	Current small-scale distributed renewable liquid feedstock reforming technologies have capital costs that are too high to achieve the DOE-defined target for hydrogen production cost.
Reformer Manufacturing	Distributed reforming units are currently designed and built one at a time. Current manufacturing processes are not sufficiently cost-effective and do not have sufficiently high throughput. Systems produced are large and non-portable.
Station Footprint	To be economically feasible in urban settings, the physical footprint of stations needs to be reduced.
Feedstock Issues	Feedstock costs, including transportation costs, are typically the single largest factor determining economic viability of hydrogen from bio-derived liquids. Liquid feedstock supplies may vary by region and season, requiring prospective bio-derived liquids reforming sites to develop diverse feedstock handling procedures and reformers that can consistently process the available range of liquid feedstock into hydrogen of acceptable quality. Biomass availability may be limited.
Operations and Maintenance	O&M costs for hydrogen production from bio-derived liquids are too high. Current systems require extensive maintenance and monitoring that cannot be accommodated at distributed production sites. There is currently no simple, low-cost way to ensure that the hydrogen meets the high standards necessary for proper fuel cell operation (as discussed in the Introduction).
Control and Safety	Bio-derived liquids reformers will need reliable controls to assure public safety and address environmental issues without escalating costs. Specifically, controls are needed to avoid chemical leakage and minimize emissions.

Feedstock Issues

Feedstock costs, including transportation costs, are typically the single largest factor determining economic viability of hydrogen from bio-derived liquids.³⁵ Feedstock availability may be limited — owing to competition for biomass or lack of crops in some areas, for example — and the lower-cost feedstock may change throughout the year. Additional feedstock issues include (1) the effects of impurities from multiple feedstocks and (2) the effects of impurities from variations in single feedstocks or those introduced during feedstock transport. Without significant reductions in feedstock cost, hydrogen from bio-derived liquids will not be economically viable.

³⁵ J. D. Holladay, K. Hu, D. L. King, and Y. Wang, “An Overview of Hydrogen Production Technologies,” *Catalyst Today* 139 (2009): 244–260.

While carbohydrate-based feedstock such as glucose could eventually be available, several barriers exist that contribute to costs. Specifically, variations in feedstock, transportation costs and logistics, and storage issues may increase. These issues must be addressed.

Operations and Maintenance

All system components (e.g., contaminant removal, reforming, controls, utilities, sensors, compression, storage, dispensing, and safety) must be considered in O&M cost projections, which currently are too high. Hydrogen quality monitoring is also a potential barrier, as described in the Introduction. Although similar to DNGR, reforming of bio-derived liquids is more complex and will require a more complicated overall system. For distributed production, however, the O&M issues related to scheduled maintenance and demand management are nearly identical to those for DNGR systems (see Section 1.2).

Catalysts. Bio-derived liquids reforming can be accomplished using gas-phase or liquid- (aqueous) phase reactions. Gas-phase reforming of liquids is very similar to natural gas reforming and has many of the same barriers. The main differences are that vaporization must occur, the catalysts may need to be adjusted, and the steam-to-carbon ratio typically needs to be higher. The primary focus of bio-derived liquid gas phase reforming has been ethanol and pyrolysis oil processing. In some ways, bio-derived liquids, especially pyrolysis oil, are more difficult to process than natural gas. Specifically, coke tends to form and deactivate the catalyst even at higher steam-to-carbon ratios than natural gas. Liquid or aqueous phase reforming (APR) is not as well developed as its gas phase reforming counterpart but offers the potential advantage of low temperature (<300°C) processing. APR has been primarily proposed for reforming of biomass or the aqueous phase of the pyrolysis oil. However, the aqueous phase of pyrolysis oil often contains significant amounts of carboxylic acid, such as acetic acid, which are very difficult to decompose to desired products. Therefore, catalyst development is a primary need for APR. For APR of bio-derived liquids, the current favored catalyst is a noble metal, so an inexpensive non-noble metal would lower the cost.

Durability. For current systems, repairs are too frequently necessary, and repair cost is too high. Down time may adversely affect co-located businesses (e.g., convenience store, car washes). The durability and service life of the reactor and the catalyst are less than satisfactory.

Contaminant Removal. The feedstock may contain trace levels of contaminants that will need to be removed prior to reforming. Both the safety of the removal operation as well as the disposal method must be appropriately designed.

Control and Safety

Control and safety barriers associated with reforming include poor performance of start-up and shut-down processes, insufficient turn-down capability, general feedstock issues, a lack of rapid on-off cycling, and feedstock storage tank refilling difficulties. Many of the control systems issues for renewable liquids reforming are the same as those for natural gas reforming. Reforming control and safety costs are high owing to complex system configurations and too many regulation-mandated sensors. The permitting process critically relies on the proven reliability and safety of these units in the forecourt environment, and these criteria will be key qualification targets. Any system design will have to meet local and national permitting requirements for effluents (gases and liquid exhaust). If underground storage tanks are used, they will need to comply with leaking underground storage tank regulations.

2.3 Strategy to Overcome Barriers and Achieve Technical Targets

Table 2.3 lists the critical technology needs for bio-derived liquid and biomass reforming hydrogen production, and these needs are discussed in the following text. Some of the R&D activities address more than one barrier.

Table 2.3. Bio-Derived Liquids Reforming — Critical Technology Needs

Reduce Capital Costs	<ul style="list-style-type: none"> → Capital cost reduction → Improved catalysts <ul style="list-style-type: none"> • Steam reforming • Autothermal reforming • Aqueous phase reforming → Low-cost separations and purification technologies → One-step reforming/shift → Manufacturing and installation <ul style="list-style-type: none"> • System optimization and load-following capability to reduce footprint • DFMA/high-volume equipment manufacturing • Reduce BOP cost
Reduce O&M Costs	<ul style="list-style-type: none"> → Low cost <ul style="list-style-type: none"> • Feedstock characterization • Supply and transportation strategies analysis • Feedstock candidates • H₂ quality assurance → Improved feedstock pre-treatment → Minimize labor cost → Increase equipment reliability → Minimize chemical and energy losses

Reduce Capital Costs

Capital equipment represents a significant cost component in hydrogen production from bio-derived liquids reforming, and reduction of these costs should be a high-priority research focus. However, some of the efforts to reduce capital costs may restrict feedstock flexibility options. A technoeconomic cost analysis for specific cases is required to determine the cost advantages on a case-by-case basis.

Improve Catalysts

Steam Reforming. A multitude of catalyst systems have been investigated for the steam reforming of ethanol, pyrolysis oil, sugar alcohols, and other bio-liquids.³⁶ A common problem with the catalysts reviewed is deactivation due to coking, which occurs when side reaction products (e.g., acetaldehyde, ethylene) deposit on the catalyst. To a certain degree, process parameters such as the steam-to-carbon ratio can be modified — in this case increased — to limit carbon deposits, but at the cost of increased process energy requirements.³⁷ The steam-to-carbon feed ratio and operating temperature also influence the selectivity to hydrogen. Steam-to-carbon molar ratios of three or greater and temperatures above 500°C have been shown to favor the production of hydrogen over methane or other reaction intermediates. However, as mentioned previously, the cost of higher steam-to-carbon ratios is increased energy inputs.

Low-temperature (<500°C) reforming technologies are also under investigation. The advantages of low-temperature technologies include reduced energy intensity, compatibility with membrane separation,

³⁶ A. Bshish, A. Ebshish, B. Narayanan, R. Ramakrishnan, and A. Yakoob, “Steam-Reforming of Ethanol for Hydrogen Production,” *Chemical Papers* 65, no. 3 (2011): 251–266; L. V. Mattos, B. H. Davis, G. Jacobs, and F. B. Noronha, “Production of Hydrogen from Ethanol: Review of Reaction Mechanism and Catalyst Deactivation,” *Chemical Reviews* 112, no. 7 (2012): 4094–4123.

³⁷ J. D. Holladay, K. Hu, D. L. King, and Y. Wang, “An Overview of Hydrogen Production Technologies,” *Catalyst Today* 139 (2009): 244–260.

favorable conditions for WGS reaction, and minimization of the undesirable decomposition reactions typically encountered when carbohydrates are heated to high temperatures.³⁸

Progress will require acquiring a better understanding of the coking mechanisms, developing kinetic models, and performing parametric studies. A better understanding of coking mechanisms may enable the identification of operating conditions that will minimize coking, the identification of materials that will inhibit coking, and the development of long-life, durable reactors. Kinetic modeling is needed to facilitate improved reactor design and development of control algorithms. Parametric studies are required to understand how the reactor will operate under various conditions and how the reactor operates under off-specification conditions. In addition, parametric studies are needed to optimize start-up and shut-down procedures. As part of these studies, strategies should be identified and developed to regenerate catalysts with reduced activity. Coking, kinetic, and parametric studies should be done on a variety of feedstocks and should include development of strategies to switch between feedstocks without shutting down. Kinetic and parametric studies will inform system design and optimization and may be used in system and process control models for distributed and central hydrogen production facilities.

Autothermal Reforming. ATR reforming has been examined to process glycerol, ethanol, and pyrolysis oil mixed with methanol using commercially available catalysts. Coking still remains a challenge in this system. The high peak temperatures in the catalyst bed, which can approach 1000°C, have a negative impact on the durability of the catalyst. In short-term laboratory tests, researchers have achieved yields up to 11 grams (g) H₂ per 100 g pyrolysis oil consumed at carbon liquid-to-gas conversions approaching 85%.³⁹

Aqueous Phase Reforming. APR is a promising technology that can process biomass or water-soluble carbohydrates such as glucose, ethylene glycol, sorbitol, glycerol, and methanol.⁴⁰ Studies have shown that the following factors promote selectivity to hydrogen rather than alkanes:

- Catalysts made of platinum, palladium, and nickel-tin (nickel catalysts favor alkane production)
- More basic catalyst support materials (e.g., alumina)
- Neutral and basic aqueous solutions
- Feedstock type (in descending order of hydrogen selectivity): polyols (selectivity decreases with increasing carbon number), glucose (selectivity decreases as weight % increases from 1 to 10).⁴¹

Catalyst coking is not a significant problem for aqueous-phase reforming compared to low-temperature steam reforming and may be the result of differences in feedstock reaction pathways. While hydrogen yields are highest from the APR of sorbitol, glycerol, and ethylene glycol; glucose reforming which has lower hydrogen yields may be more practical due to lower feedstock cost. There has been some recent work on reforming the liquid phase of pyrolysis oil in APR.⁴² Improvements in catalyst performance,

³⁸ E. Doukkali et al., “Bioethanol/Glycerol Mixture Steam Reforming Over Pt and PtNi Supported on Lanthana or Ceria Doped Alumina Catalysts,” *International Journal of Hydrogen Energy* 37, no. 10 (2012): 8298–8309; Hydrogen Program, “Hydrogen Generation from Biomass-Derived Carbohydrates via the Aqueous-Phase Reforming (APR) Process,” in *FY 2005 Progress Report*, (Washington, DC: U.S. Department of Energy, 2005), 96–97.

³⁹ S. Czernik, “Distributed Bio-Oil Reforming” (presentation, 2013 DOE Hydrogen and Fuel Cell Technologies Program Annual Merit Review & Peer Evaluation Meeting, Washington, DC, May 17, 2013), <http://www.nrel.gov/docs/fy10osti/48066.pdf>.

⁴⁰ B. Roy et al., “Effect of Preparation Methods on the Performance of Ni/Al₂O₃ Catalysts for Aqueous Phase Reforming of Ethanol: Part I – Catalytic Activity,” *International Journal of Hydrogen Energy* 37, no. 10 (2012): 8143–8153; H. D. Kim et al., “Hydrogen Production Through the Aqueous Phase Reforming of Ethylene Glycol Over Supported Pt-Based Bimetallic Catalysts,” *International Journal of Hydrogen Energy* 71, no. 10 (2012): 8310–8317.

⁴¹ D. King, “Biomass-derived Liquids Distributed (Aqueous Phase) Reforming,” (presentation, 2012 DOE Hydrogen and Fuel Cell Technologies Program Annual Merit Review & Peer Evaluation Meeting, Arlington, VA, May 17, 2012), http://www.hydrogen.energy.gov/pdfs/review12/pd002_king_2012_o.pdf.

⁴² Ibid.

reactor design, and reaction conditions may help increase hydrogen selectivity. In biomass reforming, a strong basic solution is used to aid in decomposition. Because of the high pH, high pressure and moderate temperatures, reactor construction requires expensive materials such as Inconel and Hastelloy. Similar to steam reforming, kinetic and parametric studies, including catalyst regeneration, should be conducted using the aqueous phase technology to size the reactor, develop the system, and implement a control strategy.

Develop Low-Cost Separations and Purification Technologies

Lower-cost separation and purification technologies, such as membranes, need to be developed. Membrane-specific technical targets are being addressed through research in improved membrane materials, module design, and manufacturing techniques. Improvements in membrane materials will result in membranes with greater flux and hydrogen selectivity; greater resistance to impurities such as hydrogen sulfide, nitrogen, chlorine, and sodium; and greater durability under more extreme temperature and pressure. Research in module design is focused on developing membrane configurations that increase surface area per unit volume, enable simpler manufacturing and assembly methods, and provide leak-free seals. New manufacturing techniques will provide more cost-effective and durable substrates, less energy and material-intensive manufacturing processes, and more uniform and higher-quality finished membranes.

Pursue Process Intensification

Capital cost is the second largest cost contributor to hydrogen generation costs at small on-site plants designed for forecourt refueling stations. Process intensification is a strategy that could potentially substantially reduce hydrogen production costs by introducing advanced technology that can lower capital costs by reducing the number of unit operations, improving process efficiency, and reducing equipment manufacturing and maintenance costs. An example of process intensification is a one-step reformer/shift reactor for gas phase reforming. Membrane advances may offer another opportunity for process intensification, as in the use of a membrane reactor that combines reforming and separations into a single step. Integrated production systems which include unit processes allowing for the initial use of lower-cost feedstocks, and feedstock-flexible reformers capable of producing hydrogen from a variety of bio-derived liquids may help reduce the feedstock contribution to hydrogen production costs.

Improve Manufacturing and Installation

System Optimization and Load Following Capability to Reduce Footprint. Demand for hydrogen refueling will vary significantly over the course of a day. This variable demand may be handled through a combination of on-site hydrogen storage and load following capability in the reformer. The use of storage versus load following to handle variability will have a significant impact on capital and operating costs and on station footprint. Sizing the reformer to handle peak demand will result in higher capital costs and higher feedstock costs (due to lower efficiency at off-design point operation), while using increased storage to handle peak demand may increase the footprint and material costs required for storage. This optimization must also consider the relative impact on maintenance costs and safety.

DFMA/High-Volume Equipment Manufacturing. Most of the critical technology needs in DFMA for bio-derived liquids are the same as those discussed in the DNGR section.

Reduced BOP Cost. BOP components are a significant part of the capital cost. Improved low-cost sensors, pumps, blowers, and monitoring equipment need to be developed.

Reduce Operations and Maintenance Costs

O&M costs have a significant impact on the overall cost for producing hydrogen. Improvements in process design that increase energy efficiency and/or allow for greater variability and higher levels of contaminants in feedstocks will reduce O&M costs. Development of reactors that are fuel-flexible will enable operators

to use the lowest-cost feedstocks available. Changing the feedstock should be simple and seamless. O&M costs will be further reduced by improved process controls for cycle optimization, including development of better and less expensive sensors and development of better turn-down capability. It should be noted that efforts to make reactors fuel-flexible may not be compatible with some of the efforts to reduce O&M. The advantages and disadvantages of such efforts will be dependent on the technologies and approaches and therefore must be evaluated on a case-by-case basis. The costs associated with fuel quality assurance — reducing hydrogen recovery from the pressure swing adsorption units and quality verification through gas analysis — can add several cents per kilogram to the cost of hydrogen.

Address Feedstock Issues

Feedstock Characterization. Efforts to clearly identify the range of feedstock(s) and the baseline characteristics of each major feedstock would enable closer consideration and analysis of issues such as compositional consistency between batches, storage, contaminants, waste generation/disposal, and system design. Since various feedstocks differ in carbon content, understanding the constituents is necessary to determine the amount of water needed to maintain the desired steam-to-carbon ratio. In addition, the volatility, or lack thereof, will need to be addressed. For example, bio-oil has a low volatility, but this may be overcome by cracking it in a pre-reformer. Feedstock characterization is essential to support development of a flexible fuel system.

Supply Analysis. For a feedstock to be a suitable candidate for distributed reforming, it should be inexpensive, chemically stable (e.g., pyrolysis oils need to be stabilized for storage and transport),⁴³ relatively non-toxic, easily reformed, easily transported via truck or pipeline, and available in sufficient quantity to support year-round station operation. A supply analysis may be required to identify the candidates that best meet these requirements. Some individual feedstocks may not meet all requirements yet may be useful in minimizing annual costs when included with more abundant feedstocks. Many feedstocks may be viable for use at a single station if the station can process them. A supply analysis can identify likely feedstock candidates and scenarios that stations may face. Different areas of the country are expected to use different feedstocks, which may change over time.

Feedstock Candidates. Glycerol, pyrolysis oil and biomass⁴⁴ are the most likely candidates. Glycerol is a waste stream from the production of bio-diesel. Should bio-diesel production in the United States increase significantly, relatively large amounts of glycerol may be available for hydrogen production. The DOE-EERE Bioenergy Technologies Office is developing low-cost processes to make pyrolysis oil and is supporting research to decrease feedstock. Pyrolysis oil is an attractive option since analysis has indicated that smaller plants for processing of the oil can be more economically built than the large-scale gasifiers, which were originally envisioned for ethanol production.⁴⁵ Ongoing studies indicate that the cost of hydrogen from pyrolysis oil (feedstock) may meet DOE target costs if the cost of the feedstock can be reduced significantly.⁴⁶

⁴³ T. Vispute, “Pyrolysis Oils: Characterization, Stability Analysis, and Catalytic Upgrading to Fuels and Chemicals,” Ph.D. dissertation (Amherst, MA: University of Massachusetts, 2011).

⁴⁴ Oak Ridge National Laboratory, *U.S. Billion-Ton Update: Biomass Supply for a Bioenergy and Bioproducts Industry* (Washington, DC: U.S. Department of Energy, August 2011), www1.eere.energy.gov/biomass/pdfs/billion_ton_update.pdf.

⁴⁵ J. Turner et al., “Renewable Hydrogen Production,” *International Journal of Energy Research* 32 (2008): 379–407.

⁴⁶ D. King, “Biomass-derived Liquids Distributed (Aqueous Phase) Reforming” (prepared for 2012 DOE Hydrogen and Fuel Cell Technologies Program Annual Merit Review & Peer Evaluation Meeting, Washington, DC, May 17 2012), http://www.hydrogen.energy.gov/pdfs/review12/pd002_king_2012_o.pdf. S. Czernik, “Distributed Bio-Oil Reforming” (prepared for 2012 DOE Hydrogen and Fuel Cell Technologies Program Annual Merit Review & Peer Evaluation Meeting, Washington, DC, May 17, 2012), www.hydrogen.energy.gov/pdfs/review12/pd004_czernik_2012_o.pdf.

Co-production of hydrogen at or near a pyrolysis plant or bio-fuel plant may be a viable option. Bio-fuel requires a large amount of hydrogen for hydrogenation reactions. This hydrogen is currently being provided by steam methane reforming. Low-cost hydrogen production from biomass (cellulose or carbohydrates), waste from biofuel production, or pyrolysis oil may be attractive. At this time, ethanol is the most abundant bio-derived liquid. Ethanol production and transportation infrastructures already exist and are undergoing expansion to meet the increasing demand created by the Energy Policy Act of 2005, the Energy Independence and Security Act of 2007, and other legislation.⁴⁷ However, the current high price of ethanol (\$3/gallon,⁴⁸ ~3.7¢/megajoule [MJ]) makes it less attractive. Should the cost decrease, there may be renewed interest in this fuel. Other renewable liquid options include sorbitol, glucose, methanol, propylene glycol, and less refined sugar streams (e.g., cellulose, hemicellulose). Table 2.4 lists advantages and disadvantages of potential bio-liquid feedstocks, as well as the probable reforming technology, feedstock development time frame and cost, and theoretical hydrogen yield. In the end, an environmentally sustainable feedstock with the lowest cost will be the solution.

Hydrogen Quality Assurance. One of the advantages of proton exchange membrane (PEM) fuel cells is that their performance is independent of the hydrogen source. However, hydrogen purity does affect fuel cell performance. Effects from impurities introduced by variable feedstocks must be addressed to deliver hydrogen that will maintain fuel cell durability and efficiency. Hydrogen separation and purification can meet the quality targets. However, the cost of limiting the impurity levels (especially carbon monoxide), along with the cost of gas analysis to verify the quality, can add 3 to 10 cents per kilogram of hydrogen.

Develop Feedstock Pre-Treatments

Typically, reforming catalysts require contaminant-free and de-ionized water. Feedstock pretreatment systems that achieve required feedstock and water purity can represent a significant portion of capital, operating, and maintenance costs. Feedstock candidates will need to be analyzed to determine what contaminants are present, and strategies will need to be developed to remove those contaminants. For example, crude glycerol contains salts that may need to be removed prior to reforming. For some feedstock candidates (e.g., ethanol), there will likely be no contaminants remaining after production; however, some particles, unwanted chemicals, etc., may be picked up in transportation. Bio-derived liquid reforming requires more water than natural gas reforming. The water purity needs are similar to those of natural gas reforming, as detailed in the section covering DNGR.

Reduce Labor Cost

On-site planned maintenance needs to be minimized in terms of both cost and frequency. Automated process control and remote monitoring will reduce or eliminate the need for on-site support.

Enhance Equipment Reliability

The reliability of BOP equipment (pumps, compressors, blowers, sensors, etc.) is often the limiting factor in overall system reliability. Increasing the reliability and service life of these components is critical, as is minimizing equipment complexity. For reformer systems, catalyst activity is also critical for reliable and efficient operation. Impurities in feedstocks (bio-derived liquids, water, etc.) must be removed to protect reactor components.

⁴⁷ Energy Policy Act of 2005, H.R. 6, 109th Cong. (2005), <http://www.gpo.gov/fdsys/pkg/PLAW-109publ58/pdf/PLAW-109publ58.pdf>; “Legislative Actions: State,” Renewable Fuels Association, www.ethanolrfa.org/policy/actions/state/; Renewable Fuels Association, *From Niche to Nation: Ethanol Industry Outlook 2006* (Washington, DC: U.S. Department of Energy, 2006), http://www.ethanolrfa.org/page/-/objects/pdf/outlook/outlook_2006.pdf?nocdn=1.

⁴⁸ U.S. Energy Information Administration, *Biofuels Issues and Trends* (Washington, DC: U.S. Department of Energy, October 2012), <http://www.eia.gov/biofuels/issuestrends/pdf/bit.pdf>.

Reduce Chemical and Energy Losses

Leaks of feedstock or hydrogen must be minimized. Heat loss and heat rejection must also be minimized through well-designed insulation and heat integration.

Table 2.4. Potential Bio-Liquid Reforming Feedstocks

Bio-Liquid	Time Frame ^{a,b}	Bio-Liquid Cost (Plant – Gate)	Theoretical Hydrogen Yield	Feedstock Advantages/Disadvantages
Denatured Ethanol	Mid-term	\$2.47/gallon ^c	0.78 kg H ₂ /gallon ethanol 0.26 kg H ₂ /kg ethanol	Low toxicity
				Low sulfur content
				Use of dilute ethanol would reduce reforming feedstock costs
				Ethanol production/delivery infrastructure is already established
Glucose	Mid-term	\$0.07/lb ^d	0.13 kg H ₂ /kg glucose	Low volatility
				Non-toxic, non-flammable
Glycerol	Mid-term	\$0.15/lb (80% glycerol, ~20% water from biodiesel production) ^e	0.15 kg H ₂ /kg pure glycerol	Utilizes low-value glycerol by-product from biodiesel production
				Low volatility
				Non-toxic, non-flammable
Crude Glycerol (CG)	Mid-term	<\$0.15/lb ^f	0.24 kg H ₂ /kg CG	Low volatility
Pyrolysis Oil	Mid-term	\$0.03-0.04/lb pyrolysis oil ^g	0.14 g H ₂ /100 g pyrolysis oil	High reactivity; potential of forming carbonaceous deposits or converting to aromatics that are more difficult to reform to H ₂
Sorbitol	Long-term	\$0.10/lb ^h	0.13 kg H ₂ /kg sorbitol	Low volatility
				Non-toxic, non-flammable
Ethylene Glycol (EG) and Propylene Glycol (PG)	Long-term	EG: \$0.44-0.46/lb ⁱ PG: \$0.71-1.02/lb ⁱ	0.15 kg H ₂ /kg EG 0.22kg H ₂ /kg PG	Low volatility
				Non-toxic (PG), non-flammable (both)
Cellulose/Hemicellulose	Long-term	\$0.07/lb ^j	~0.13 kg H ₂ /kg cellulose/hemicellulose	Low volatility
				Non-toxic, non-flammable
Methanol	Long-term	\$0.78-0.91/gallon ^j	0.64 kg H ₂ /gallon methanol; 0.22 kg H ₂ /kg methanol	More easily reformed to hydrogen than ethanol
				High toxicity
				Higher corrosivity, volatility than ethanol

^a Time frames are defined as follows: near-term – 2012; mid-term – 2012–2020; long-term – 2020+.

^b Time frame is based on the market readiness of both the reforming technology and the bio-liquid production and distribution infrastructure.

^c This is the DOE-EERE Biomass Program target for cellulosic ethanol in 2012.

Table 2.5. (Cont.)

- ^d This glucose price from the 2004 H2A Central Sorbitol Production analysis assumes an nth plant bio-refinery with glucose as one product.
- ^e Methanol, fatty acids, and most of the water have been removed.
- ^f Assumes the cost of crude glycerol is lower than semi-purified glycerol. Crude glycerol is defined as 55% glycerol and 45% methyl esters of fatty acids.
- ^g This represents the DOE-EERE Biomass Program 2010 and 2020 pyrolysis oil production cost goals of \$5.10/MMBtu and \$4.30/MMBtu, respectively. Bio-oil energy content is assumed to be 7.500 Btu/lb.
- ^h This is from the 2004 H2A Central Sorbitol Production analysis (2000\$) using \$0.07/lb glucose.
- ⁱ This is the cost of the fossil-derived product. The bio-based product will have to be cost-competitive.
- ^j These numbers are consistent with the target cost of cellulosic sugar for ethanol production in 2012 in the DOE-EERE Biomass Program.

3.0 Coal and Biomass Gasification

Gasification is a mature technology with the potential to produce a significant amount of low-cost hydrogen for the United States. Currently, this technology is being applied to areas other than hydrogen generation, such as electrical power and heat production, chemical production, and synthetic fuel production.

3.1 Current Status and Technical Targets

Gasification of carbonaceous feedstocks produces synthesis gas (primarily CO and H₂) that can be converted to hydrogen and carbon dioxide via the WGS reaction. The coal and biomass gasification pathway produces hydrogen via thermochemical processing of coal and biomass in central facilities. The DOE-FE office’s R&D portfolio addresses technology developments to increase gasification efficiency; reduce capital and operating costs; implement carbon capture, utilization and storage (CCUS); and increase availability of all types of coal and biomass.

Projected high volume costs for hydrogen production via biomass gasification are shown in Table 3.1. Capital and feedstock are the major contributors to cost (73%).⁴⁹

Coal gasification is a potentially inexpensive way to convert coal into hydrogen as well as electricity and other valuable materials.⁵⁰ Commercial plants utilizing coal gasification are operating in the United States and other nations today. However, for coal to be viable in a carbon-constrained world, efficient carbon capture and storage technologies need to be implemented. Biomass gasification has a smaller carbon footprint than coal, but feedstock cost, reliability, and sustainability issues associated with using biomass must be addressed. Co-gasification of coal and biomass leverages the abundance and low cost of coal with the renewable benefits of biomass. Coal and biomass can be co-utilized to reduce the carbon footprint while allowing biomass to take advantage of the economies of scale associated with coal to produce clean hydrogen with virtually zero criteria pollutant emissions.

DOE Cost Targets

R&D on the coal and biomass gasification pathway focuses on achieving the DOE-defined, plant-gate cost targets for hydrogen production shown in Table 3.1.⁵¹ Analysis on hydrogen from coal

Coal and Biomass Gasification



Feedstock:	Coal Biomass
Energy Source:	Coal Biomass
Production:	Semi-Central Central

Environmental Benefits

Co-gasification of coal and biomass leverages the abundance and low cost of coal with the renewable nature of biomass. DOE is working on developing efficient carbon capture and storage technologies for coal and on reducing cost and supply issues for biomass. For more information on DOE’s carbon capture and storage activities see

www.fe.doe.gov/programs/sequstration/index.html.

⁴⁹ Office of Energy Efficiency and Renewable Energy, *Fuel Cell Technologies Office Multi-Year Research, Development, and Demonstration Plan* (Washington, DC: U.S. Department of Energy, November 2012), Section 3.1, www1.eere.energy.gov/hydrogenandfuelcells/mypp/.

⁵⁰ Fossil Energy Office of Communication, “Gasification Technology R&D,” U.S. Department of Energy, www.fossil.energy.gov/programs/powersystems/gasification/index.html.

⁵¹ Office of Energy Efficiency and Renewable Energy, *Fuel Cell Technologies Office Multi-Year Research, Development, and Demonstration Plan* (Washington, DC: U.S. Department of Energy, November 2012), Section 3.1, www1.eere.energy.gov/hydrogenandfuelcells/mypp/.

with CCUS using the best currently available technologies provide similar values to those shown in Table 3.1.⁵²

Table 3.1. Biomass Gasification Hydrogen Production — DOE Cost Targets (\$/gge [plant gate])⁵³

Characteristics	Unit	2011 Status	2015 Target	2020 Target
Hydrogen Levelized Cost	\$/gge	2.20	2.10	2.00
Total Capital Investment	\$M	180	180	170
Energy Efficiency	%	46	46	48

Coal and Biomass Feedstocks

Coal is an abundant domestic resource, with the United States boasting hundreds of years of supply at current demand levels.⁵⁴ Additionally, over a quarter of the world’s known coal reserves are found within the United States.⁵⁵ Coal is a resource that the United States has in abundance and that could be exploited for hydrogen production at the central production size range (>50,000 kg/day).

Another major resource that the United States can tap for energy is biomass, with the potential for over a billion dry tons available annually.⁵⁶ In general, the two types of biomass feedstocks available for use in hydrogen production are (1) primary biomass such as energy crops like poplar, willow, and switchgrass and (2) biomass residues from sources such as animal waste, wood or processed agricultural biomass, and municipal solid waste.⁵⁷

3.2 Gaps and Technical Barriers

DOE’s research activities are driven by specific barriers identified in the MYRD&D and the DOE-FE’s Hydrogen from Coal program RD&D plan, as well as others identified by the U.S. DRIVE Partnership’s HPTT and the 2011 independent review of cost estimates for hydrogen from biomass gasification.⁵⁸ These are summarized in Table 3.2 and described more fully on the following pages.

⁵² National Energy Technology Laboratory, *Production of High Purity Hydrogen from Domestic Coal: Assessing the Techno-Economic Impact of Emerging Technologies*, DOE/NETL-2010/1432 (Washington, DC: U.S. Department of Energy, August 30, 2010), www.netl.doe.gov/energy-analyses/pubs/H2fromcoaltech2010.pdf.

⁵³ Office of Energy Efficiency and Renewable Energy, *Fuel Cell Technologies Office Multi-Year Research, Development, and Demonstration Plan* (Washington, DC: U.S. Department of Energy, November 2012), Section 3.1, www1.eere.energy.gov/hydrogenandfuelcells/mypp/.

⁵⁴ Fossil Energy Office, *Hydrogen from Coal Program Research, Development, and Demonstration Plan*, External Draft (Washington, DC: U.S. Department of Energy, September 2010), http://fossil.energy.gov/programs/fuels/hydrogen/2010_Draft_H2fromCoal_RDD_final.pdf.

⁵⁵ Ibid.

⁵⁶ Oak Ridge National Laboratory, *U.S. Billion-Ton Update: Biomass Supply for a Bioenergy and Bioproducts Industry* (Washington, DC: U.S. Department of Energy, August 2011), www1.eere.energy.gov/biomass/pdfs/billion_ton_update.pdf.

⁵⁷ National Research Council and National Academy Of Engineering, *The Hydrogen Economy: Opportunities, Costs, Barriers, and R&D Needs* (Washington, DC: National Academies Press, 2004), <http://www.nap.edu/openbook.php?isbn=0309091632>.

⁵⁸ National Renewable Energy Laboratory, *Hydrogen Production Cost Estimate Using Biomass Gasification*, NREL/BK-6A10-51726 (Washington, DC: U.S. Department of Energy, October 2011), www.hydrogen.energy.gov/pdfs/51726.pdf.

Table 3.2. Coal and Biomass Gasification — Summary of Barriers

Emissions (primarily coal)	GHG emissions, specifically carbon dioxide, result from the use of coal. Technologies to capture and store these emissions effectively are not economically viable.
Feedstock Issues (primarily biomass)	Sources and supplies of feedstock are not consistent or reliable with respect to composition and quality. Feedstock preparation, storage and handling systems, and transportation are all costly and underdeveloped. In addition, competition for biomass may limit its availability in some geographic areas.
Capital Costs	Current gasification systems are capital-intensive because of non-standardized plant designs and inefficient, multi-step processes. Hydrogen quality requirements for PEM fuel cells also result in significant capital costs.
Operations and Maintenance	O&M costs need to be reduced. BOP equipment needs to be made more efficient and durable than that which is currently available. Feedstock on-site storage, handling, and preparation need to be improved. Hydrogen monitoring also increases O&M costs. Additional data and demonstration of the numerous combinations of coal and biomass types and concentrations that can be co-fed into high-pressure gasifiers would be useful.
Control and Safety	Improved sensors and controls that enable feed-flexible operation would reduce costs.

Emissions (Primarily Coal)

Coal gasification generates significant amounts of GHG emissions, specifically carbon dioxide. Other emissions are regulated and are currently being addressed by existing gasification facilities. They do not pose a significant technical barrier, but they do have significant costs associated with them.

Greenhouse Gas Emissions. Coal is primarily carbon. During the gasification process, the carbon is partially oxidized in the presence of oxygen and steam to produce synthesis gas, a mixture of carbon monoxide (CO), hydrogen (H₂), carbon dioxide (CO₂), and trace amounts of other compounds. Additional hydrogen is then produced in a second process called WGS, which reacts the CO with water (H₂O) to produce CO₂ and H₂. Reducing GHG emissions is one of the primary goals in developing hydrogen technologies. Using current projections, without carbon capture, each kilogram of hydrogen produced from coal produces 22 kilograms (CO₂ equivalent) of greenhouse gases, compared to 4 kilograms with carbon capture.⁵⁹ Without sufficient separation and capture of CO₂, the advantages of hydrogen are negated.

Renewable feedstocks generate significantly lower lifecycle GHG emissions than petroleum and other hydrocarbon fuels. Some GHG emissions are associated with biomass feedstock production and collection activities, and the DOE Bioenergy Technologies Office is addressing these issues. Emissions may also be associated with the production of electricity to power auxiliary equipment at gasification facilities. GHG emissions associated with gasification increase as a result of a number of factors, such as the following:

- Inefficiency of converting the feedstock to hydrogen
- Inefficiency during the handling/preparing of feedstocks
- Emissions during the gasification process
- Suboptimal hydrogen separation processes.

⁵⁹ Hydrogen and Fuel Cells Program, “Productions Case Studies,” U.S. Department of Energy, www.hydrogen.energy.gov/h2a_prod_studies.html.

Feedstock Issues (Primarily Biomass)

Biomass feedstock issues include cost, quality, availability, on-site storage, handling, and conversion to useful form.⁶⁰ To meet a 50,000 kg/day hydrogen production rate, the gasification plant is designed to process 675 dry metric tons of biomass per day.⁶¹ The DOE Bioenergy Technologies Office reports 2011 woody biomass feedstock costs to be \$57.30 per dry ton delivered to the plant gate, with most of the cost associated with the logistics of getting the feedstock from the field to the plant gate (\$15.20/dry ton minimum grower payment and \$42.10/dry ton in feedstock logistics to plant gate).⁶² Owing to increased demand, biomass grower payment costs are projected to rise to \$24.90/dry ton delivered by 2017 and to \$30.30/dry ton delivered by 2022.⁶³ The analysis in Table 3.1, done before the current Bioenergy Technologies Office report, uses different feedstock cost estimates that are broadly similar, though higher.⁶⁴ Transportation costs, associated in part with increased demand, also constitute a substantial barrier. In addition to cost, biomass feedstock quality and availability may be limited in some areas, or the quality of the feedstock may change throughout the year. Effects of impurities on the system from multiple feedstocks and from variations in single feedstocks will affect the gasifier system design. Once the biomass feedstock is on site, issues of storage, handling, and preparation will affect production cost. Most gasifiers require the feedstock to be dried and ground prior to use.

Capital Costs

Since coal and biomass gasification is a capital-intensive process, capital cost is a key barrier. Capital costs are increased by non-standardized plant designs and inefficient, multi-step reforming processes. The BOP costs associated with maintaining high reliability and safety standards are high. Additionally, inadequate system durability and lifespan, as well as certifications, codes, and standards requirements, increase capital costs. Hydrogen quality requirements for use in fuel cell vehicles are stringent, and satisfying these stipulations is a challenge for incumbent technology.

Some gasifier technologies use large amounts of oxygen. Air can be directly fed to the gasifier to provide the oxygen; however, the nitrogen in the air dilutes the product stream and increases the cost of hydrogen separation and purification. Alternatively, pure or nearly pure oxygen can be fed to the gasifier, but air separation units tend to be large and expensive. Lower-cost oxygen separation units are needed.

The syngas produced by the gasifier is composed mostly of carbon monoxide, carbon dioxide, hydrogen, and trace amounts of impurities such as particulates, alkali, ammonia, chlorine, sulfur, toxic metals (e.g., mercury, arsenic) and, in the case of biomass, tar/pyrolysis oil. Prior to feeding the syngas to the WGS reactors, cleanup is required to remove the majority of these trace contaminants. Quality requirements for hydrogen for use in fuel cell vehicles are becoming increasingly stringent (reductions of some contaminants to the parts per billion [ppb] level), and satisfying these stipulations is a challenge for incumbent technologies.

⁶⁰ Hydrogen and Fuel Cells Program, “Current Central Hydrogen Production via Biomass Gasification version 3.0,” U.S. Department of Energy, www.hydrogen.energy.gov/h2a_prod_studies.html; Hydrogen and Fuel Cells Program, “Future Central Hydrogen Production via Biomass Gasification version 3.0,” U.S. Department of Energy, www.hydrogen.energy.gov/h2a_prod_studies.html.

⁶¹ Office of Energy Efficiency and Renewable Energy, *Fuel Cell Technologies Office Multi-Year Research, Development, and Demonstration Plan* (Washington, DC: U.S. Department of Energy, November 2012), Section 3.1, www1.eere.energy.gov/hydrogenandfuelcells/mypp/.

⁶² Office of Energy Efficiency and Renewable Energy, *Biomass Multi-Year Program Plan* (Washington, DC: U.S. Department of Energy, April 2013), www1.eere.energy.gov/biomass/pdfs/mypp_april_2012.pdf.

⁶³ Ibid.

⁶⁴ Office of Energy Efficiency and Renewable Energy, *Fuel Cell Technologies Office Multi-Year Research, Development, and Demonstration Plan* (Washington, DC: U.S. Department of Energy, November 2012), Section 3.1, www1.eere.energy.gov/hydrogenandfuelcells/mypp/.

Operations and Maintenance

O&M costs comprise ~10% of the cost of hydrogen from biomass gasification. More efficient and durable system and BOP equipment is required. On-site feedstock storage, handling, and preparation are barriers to be addressed. Hydrogen quality monitoring also increases the O&M costs, as described in the Introduction.

O&M barriers in a number of areas will need to be addressed to achieve DOE hydrogen cost targets. All system components must be considered in O&M, including feed pre-conditioning (grinding, drying, etc.), gasification, controls, utilities, QA/QC (sensors), compressors and other BOP, storage, and safety. Other areas in which O&M barriers persist include equipment durability and reliability, oxygen plant optimization, scheduled maintenance, feedstock issues, material loss minimization, energy loss reduction, waste disposal, and hydrogen quality.

Durability. Both the frequency and cost of repairs must be considered. Catalysts for some WGS reactors and some gasification technologies require enhanced catalyst durability and lifetime as well as increased tolerance to impurities and operating temperatures.

Equipment Reliability. The reliability of equipment (such as pumps, compressors, blowers, sensors, and other BOP) is often a limiting factor in overall system reliability. Incumbent equipment is often too complex and does not meet reliability needs for O&M cost targets.

Oxygen Plant Optimization. Gasification technology uses oxygen and steam to partially oxidize the coal to carbon monoxide and hydrogen. Air can be injected into the gasifier, but the large amount of nitrogen dilutes the exit gas stream containing hydrogen and increases the cost of the hydrogen separation process. Therefore, oxygen is separated from the air prior to injection into the gasifier, but this is also costly and requires a significant amount of energy.

Scheduled Maintenance. Frequent scheduled maintenance and on-site maintenance staff are costly. Robust systems that require little routine maintenance will require automated system troubleshooting.

Feedstock Handling Issues. Biomass feedstock supplies, consistency, distribution, cost, preparation, handling, and on-site storage issues need to be addressed.

Minimized Material and Energy Losses. On-site feedstock storage, handling, and preparation must be efficient in terms of energy while also minimizing feedstock waste. Gas leaks result in loss of process efficiency, decreased safety, and excessive GHG emissions. Heat loss and heat rejection are also barriers to system efficiency.

Waste Disposal. For O&M, permitting, storage, and disposal issues may need to be addressed for gas emissions and for liquid and solid wastes. These issues will depend on the feedstock and the technology employed. Waste generation associated with current conversion rates, and alternative markets for these wastes, should be investigated and characterized.

Hydrogen Quality. Continuous hydrogen quality monitoring may be required for central hydrogen production. This topic is discussed in the Introduction.

Control and Safety

Control and safety issues associated with gasification technologies need to be further addressed. These issues are particularly important in the biomass and co-gasification scenarios, in which the type, quality, and/or mix of biomass feedstock may vary. More generally, high control costs persist because of a lack of system simplification, system standardization, and reduced sensor count. Certifications, safety codes, and

standards should be standardized and met. These units must be designed to operate in an environment of minimal manual assistance, which will entail attributes such as back-up fail-safe mode and sparse maintenance schedules. The system design faces barriers in meeting all requirements of local and national permitting processes for any resulting effluents. The above should be addressed by industrial risk management strategies during technology deployment.

3.3 Strategy to Overcome Barriers and Achieve Technical Targets

Table 3.3 lists critical technology needs for coal and biomass gasification for hydrogen production, and a discussion of these efforts follows. Note that a single R&D activity may address more than one barrier or multiple R&D activities may be needed to address a single barrier.

Table 3.3. Coal and Biomass Gasification — Critical Technology Needs

Reduce Capital Costs	<ul style="list-style-type: none"> → Reactor capital costs → Low-cost separation and purification technologies → Improved catalysts → Low-cost coal and biomass feed preparation and handling → Carbon capture and storage → Balance of plant
Reduce O&M Costs	<ul style="list-style-type: none"> → System durability and robustness → Emission controls → Feedstock storage, preparation, and handling → Hydrogen quality monitoring

Reduce Capital Costs

Individual unit operations that have the potential for capital cost reductions include the gasification itself, WGS reactors, hydrogen separation/purification, oxygen separation, syngas cleanup, and hydrogen compression/storage. To substantially decrease the plant capital cost, elimination of some unit operations may be required. Process intensification involves developing novel technologies that combine multiple processes into one step, use new control methods, or integrate alternative energy technologies with hydrogen from coal technologies.

For example, tar reformers in biomass gasification could be combined with WGS reactors, or such reactors can be combined with hydrogen separation and purification technologies. Advanced hydrogen membranes can be used to lower the cost of capturing carbon or to carry out the WGS reaction simultaneously. On a larger scale, the gasifier itself could be integrated with existing commercial processes such as electricity cogeneration. Similarly, a biomass gasifier may be integrated with an alcohol production plant,⁶⁵ with a paper mill to gasify the solid organic wastes, or with a municipal waste facility.

Additional activities that can contribute to reducing capital costs include increasing system durability/lifespan; developing low-cost feedstock preparation and handling equipment; developing carbon capture, utilization, and storage technology; and developing common certifications, codes, and standards.

Reactor Capital Costs. Capital costs for gasification plants can be reduced by designing more efficient and less expensive units or through process intensification, whereby multiple units are combined.

⁶⁵ INEOS, “Indian River Bioenergy Center” (Addyston, OH: INEOS), http://www.millerdewulf.com/The_Miller_De_Wulf_Corp/PDF/VeroBeachfactsheet.pdf.

Additionally, the co-gasification of different coal and biomass types is not well understood and needs further investigation regarding feeding systems and characterization of the synthesis gas and potential downstream impacts. A stronger fundamental understanding of the mechanisms in both the gasifier and the reforming reactions may help in designing more efficient reactors and conditions that would maximize production while decreasing costs.

Separation and Purification. PEM fuel cells require highly pure hydrogen, which places a significant requirement on hydrogen separation and purification technologies. More robust and cost-effective hydrogen separation and purification technologies may lead to reduced capital and costs and improved efficiency.

Improved Catalysts. The WGS and tar reformers need improved catalysts that are tolerant to impurities such as sulfur. Membrane reactors may be able to combine the WGS and separation processes, also decreasing the capital costs.

Balance of Plant. More durable, efficient, and robust BOP components (pumps, blowers, air separation units, water purification, desulfurization, emission controls, sensors, and other components) are needed.

Feed Preparation and Handling. Improved feed preparation and handling equipment and processes are needed to decrease capital and operating costs. The equipment should be able to process multiple types of feedstocks, particularly for biomass applications.

Carbon Capture, Utilization, and Sequestration. Analyses indicate that sufficient CO₂ storage resources often exist in close proximity to where coal is found and used.⁶⁶ Improving the efficiency of CO₂ capture and storage and developing new methods will reduce the associated costs. Improved and lower-cost approaches to carbon capture and storage need to be identified and developed.

Reduce Operations and Maintenance Costs

O&M costs need to be addressed through several R&D needs. System component integration and low-cost separation/purification and monitoring technologies will help drive down these costs. Improved oxygen separations will reduce the energy costs and improve the process efficiency. Energy losses must also be minimized through well-designed insulation and heat integration.

System Durability, Robustness, and Lifespan. Coal and biomass gasification units require regularly scheduled maintenance, which requires that they be taken off-line. Increasing system durability and robustness would decrease the down time, resulting in lower O&M costs. In addition, system component integration and low-cost separation/purification and monitoring technologies will help drive down O&M costs.

Emission Controls. Improved unit operations that are more efficient and less expensive to operate are required to handle the pollutant emissions found in coal and, to a lesser extent, biomass. BOP energy efficiency improvements will lower overall GHG emissions by reducing the use of grid electricity and reducing feedstock use for energy production. In addition, plant footprint reduction, design for manufacturing, and systems integration efforts have the potential to reduce lifecycle GHG emissions by reducing the energy and materials used to manufacture plant equipment.

⁶⁶ Fossil Energy Office of Communications, “Carbon Sequestration,” U.S. Department of Energy, www.fossil.energy.gov/programs/sequestration/index.html.

Feedstock Storage, Preparation and Handling. More robust, efficient, flexible, and inexpensive feedstock storage, preparation, and handling systems are needed. The best way to reduce these costs may be to increase feedstock supply and decrease transportation costs. Transportation costs can be reduced more effectively for distributed, medium-sized (semi-central) plants rather than larger central facilities. One way to decrease biomass feedstock issues is to co-gasify it with coal. Co-gasification decreases the carbon impact of the coal since the biomass is considered renewable, and this process promotes biomass use by decreasing the feedstock issues (coal is more cost-effective, available, and easier to handle). Efficient, feedstock-flexible gasifiers are needed to address location-specific feedstock supply and quality issues. Gasifiers that can operate efficiently with a wet stream may lower costs. Development may also be required for in-plant feedstock handling systems that can economically and efficiently convert a wide range of feedstocks into a consistent form so that existing, low-cost feeders can function reliably.

Hydrogen Quality Monitoring. Hydrogen quality monitoring requires developments of standard test methods that can detect some contaminant species at very low levels.

4.0 Water Electrolysis

The near-term pathway for hydrogen production through water electrolysis calls for using the existing infrastructure for water and electricity. GHG impacts of this technology will be greatly reduced when the electricity to power the electrolysis is supplied by near-zero emissions sources such as wind or solar energy.

4.1 Current Status and Technical Targets

Water electrolysis capability is being pursued for distributed, semi-central, and central production. Production systems will generate hydrogen with alkaline, PEM, or solid oxide electrolyzers. DOE’s current R&D priorities focus on capital cost reduction, efficiency improvements, materials development, and integration with renewable electricity sources.

Initially, water electrolysis is expected to be deployed on site at distributed/ forecourt hydrogen refilling stations, where it could stimulate market acceptance. Distributed commercial hydrogen production via water electrolysis is considered a near- to mid-term technology. In the longer term, centralized production has the potential to expand substantially the commercial supply of hydrogen by water electrolysis. Larger semi-central and central production via wind and nuclear heat and power is being investigated by both EERE and NE within DOE.

Water Electrolysis

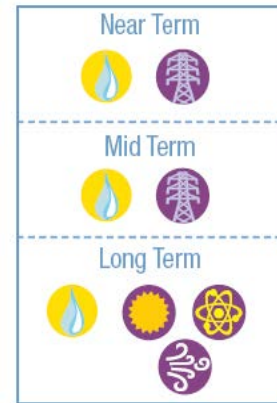

Feedstock:	Water
Energy Source:	Grid Wind Solar Nuclear
Production:	Distributed Semi-Central Central

DOE Cost Targets

R&D on the water electrolysis pathway focuses on achieving the established at-the-pump cost DOE targets for hydrogen production, as shown in Table 4.1.⁶⁷

Production Scale

Distributed hydrogen production has near- to mid-term potential because many existing forecourt stations may be able to incorporate an electrolysis unit, albeit with potentially higher electricity costs compared to central production. Low-temperature, modular units have the potential to be reasonably small (~100 kg/day) and able to use the existing water and electricity infrastructures, although this deployment scenario may require changes to current codes and standards.⁶⁸ The compact, modular nature of the technology will enable hydrogen

Environmental Benefits

Hydrogen production by water electrolysis has the potential for positive environmental impacts. Carbon emissions from grid electricity will decrease as carbon capture and storage technologies are developed and implemented for power plants and as electricity is increasingly generated with renewable and nuclear power. Capture and storage of carbon dioxide emissions is not feasible for use on the 225 million vehicles traveling over 8 billion miles per day in the United States. However, grid-powered electrolysis centralizes the emissions, improving the feasibility of a technology solution to address the issue. Other emissions, such as NOx, VOC, and especially carbon monoxide, would be significantly reduced through use of hydrogen as a transportation fuel.

⁶⁷ Office of Energy Efficiency and Renewable Energy, *Fuel Cell Technologies Office Multi-Year Research, Development, and Demonstration Plan* (Washington, DC: U.S. Department of Energy, November 2012), Section 3.1, www1.eere.energy.gov/hydrogenandfuelcells/mypp/.

⁶⁸ National Research Council and National Academy Of Engineering, *The Hydrogen Economy: Opportunities, Costs, Barriers, and R&D Needs* (Washington, DC: National Academies Press, 2004), <http://www.nap.edu/openbook.php?isbn=0309091632>.

production to grow as demand increases simply by adding electrolysis units. This modularity decreases initial installation costs. In addition, this forecourt production can stimulate market acceptance and foster demand while central production and pipeline distribution infrastructures develop.

Table 4.1. Water Electrolysis — DOE Cost Targets (\$/ggea)⁶⁹

Year	Distributed H ₂ Production (Production Only) ^b	Central H ₂ Production (Plant Gate) ^c
2011 Status	\$4.20	\$4.10
2015 Target	\$3.90	\$3.00
2020 Target	\$2.30	\$2.00

^a Targets are based on 2007 capital costs.
^b For the 2011 and 2015 status, the 2009 AEO Reference Case was used and is equivalent to a constant electricity price of \$0.061/kWh and \$0.069/kWh, respectively. A constant electricity price of \$0.037/kWh was used for the 2020 status.
^c For the 2011 status, the 2009 AEO Reference Case was used and is equivalent to a constant electricity price of \$0.063/kWh. Constant electricity prices were used for the 2015 and 2020 cases and are \$0.049/kWh and \$0.031/kWh, respectively.

The electricity costs and GHG emissions associated with this technology will vary widely from one region to another. Analyses indicate that using the current grid mix will increase GHG emissions compared to gasoline vehicles on a well-to-wheels basis, even if the hydrogen is used in the highly efficient fuel cell vehicles under development.⁷⁰ However, grid GHG emissions are already decreasing as a result of natural gas substitution for coal in power generation, and future electricity generation is projected to make increasing use of renewable resources and cleaner technologies such as carbon capture and storage for fossil fuel power plants.

Central hydrogen production at larger facilities can take advantage of economies of scale. Water can be obtained and treated in high volumes at low cost. Large electrolysis modules can be built, and cascaded modules can then be brought on line as needed. Central production can also benefit from co-generation of electricity, with the hydrogen and the electricity generated on site from low-carbon sources.

Electrolytic hydrogen production may be particularly useful for load-leveling of the electricity generated from wind turbines, reducing fluctuations in capacity or augmenting capacity during periods of peak electricity demand. Thus, it may be feasible to negotiate favorable electricity rates by operating the electrolyzers during off-peak periods (>90% of the time). Electrolyzers can potentially have a secondary use for grid stabilization (e.g., by mitigating frequency disturbances), which could help the overall economics. As a further example, in Europe, electrolysis is being pursued as a means of grid stabilization through hydrogen storage. In one approach, excess wind energy, which otherwise would not be utilized, is used to make hydrogen via electrolysis which is then injected into the natural gas grid as a means of storage and improved energy efficiency.

⁶⁹ Office of Energy Efficiency and Renewable Energy, *Fuel Cell Technologies Office Multi-Year Research, Development, and Demonstration Plan* (Washington, DC: U.S. Department of Energy, November 2012), Section 3.1, www1.eere.energy.gov/hydrogenandfuelcells/myrpp/.

⁷⁰ Anup Bandivadekar et al., *On the Road in 2035: Reducing Transportation's Petroleum Consumption and GHG Emissions*, Report No. LFEE 2008-05 RP (Cambridge, MA: Massachusetts Institute of Technology, July 2008), http://mitei.mit.edu/system/files/On%20the%20Road%20in%202035_MIT_July%202008.pdf.

Finally, there are possible advantages to high-temperature electrolysis operations using available waste heat from sources such as concentrated solar power or next-generation nuclear reactors. DOE-NE has examined the option of using waste heat from nuclear power plants to provide thermal energy for high-temperature electrolysis. High-temperature electrolyzers require about two-thirds of the electrical energy needed by low-temperature electrolyzers to produce the same amount of hydrogen; the additional energy is provided by heat added to the system.⁷¹ The year 2007 was the first time in 25 years that U.S. stakeholders participated in serious discussion of building new domestic nuclear power plants. The current status of the applications submitted during this revival can be found here: <http://www.nrc.gov/reactors/new-reactors/col/new-reactor-map.html>. Two sites were licensed in 2012; eleven others are in process.

4.2 Gaps and Technical Barriers

Driving DOE's research activities are specific barriers identified in the MYRD&D as well as others identified by the U.S. DRIVE Partnership's HPTT. These are summarized in Table 4.2 and described more fully below.

Table 4.2. Water Electrolysis — Summary of Barriers

System Efficiency and Electricity Cost	Electricity is the dominant cost in water electrolysis hydrogen production. System inefficiencies result in significant power cost requirements.
Renewable and Nuclear Electricity Generation Integration	Supply variability in renewable sources of power and inefficient conversion technologies pose barriers to integrating water electrolysis with renewable energy. Power conversion and other system component barriers inhibit high-efficiency, low-cost, integrated hydrogen production from nuclear sources.
Capital Costs	Capital costs for current electrolyzer technologies are a barrier to attaining the targeted hydrogen production cost. High capital costs are caused by expensive materials, relatively small systems, relatively low efficiencies, customized power electronics and other BOP components, and labor-intensive fabrication.
Manufacturing	Current electrolysis units are assembled using low-volume manufacturing techniques. Mass production is capital-intensive, while substantial returns on investments are not assured. Current designs are insufficiently reliable and require intensive labor and a large number of parts.
Operations and Maintenance	O&M costs for water electrolysis systems are currently too high. Frequent routine maintenance and on-site staff are prohibitively expensive.
Grid Electricity Emissions	The current grid electricity mix in most areas adds significantly to the electrolysis systems' lifecycle carbon footprint. Low-cost, carbon-free electricity generation is not yet widely available.
Control and Safety	Costs associated with control and safety are too high. Current certifications, codes, and standards are inconsistent, complicating oversight. Nuclear generation presents special control and safety issues.

System Efficiency and Electricity Cost

For electrolyzers in all applications, electricity is the most significant portion of the hydrogen production cost. Major inefficiencies exist in current electrolysis stacks, drying subsystems, and power electronics.

⁷¹ J. D. Holladay, K. Hu, D. L. King, and Y. Wang, "An Overview of Hydrogen Production Technologies," *Catalysis Today* 139 (2009): 244–260.

Current low-temperature electrolysis stacks and systems are up to 74% and 67% efficient, respectively (based on the lower heating value [LHV] of hydrogen and all systems and auxiliaries except compression). Based on analysis to achieve the DOE cost targets, stack efficiency needs to be increased to 77% (LHV), and the system should be made 75% (LHV) efficient, including all auxiliaries except compression.⁷² The primary losses associated with the electrolyzer stack are currently in the oxygen-generating electrode. Improved catalysts and membranes may enable some efficiency improvements. In addition, operating at high temperatures, made possible with use of solid oxide electrolyzer technology, will increase the systems' electrical efficiency. These higher-temperature systems will need greater durability, requiring development of corrosion-resistant materials and improved seals.

Producing the hydrogen at higher pressures within the electrolyzer stack may decrease the need for compressors and make it feasible to eliminate the compressors completely in some applications. Water electrolysis is carried out most commonly at lower pressures (100-300 psig), but current laboratory testing shows it can be performed at pressures as high as 5,000 psig. Losses in stack efficiency and throughput limitations resulting from high-pressure operation may be compensated by reductions in compression costs. Optimization of high-pressure electrolyzer operation and subsequent compression is needed to determine the proper balance.

Once the hydrogen is produced, residual water needs to be removed prior to compression. Depending on the method used to dry the gas, 10% or more of the generated hydrogen may be lost, or a significant amount of electricity may be consumed. Improved processes must be identified and deployed to decrease these losses.

Power electronics that convert alternating current (AC) power to direct current (DC) power suitable for electrolysis operation can be the source of significant power losses. Power supplies are often quoted at 90% to 95% efficiency, but in the field, testing has shown otherwise. At higher temperatures and non-optimal varying operating currents, the measured efficiency can be closer to 75% to 80%.

Renewable and Nuclear Electricity Generation Integration

Better integration of electrolysis systems with renewable energy is needed. The chief concern in powering water electrolysis with renewable energy is the variability of the renewable energy source. Wind and solar systems require grid back-up or sufficient storage to weather the times of low resource availability. (Based on high storage costs, the most likely scenario is grid back-up.) Integration with nuclear generation presents barriers associated with system component designs as well as with certifications, codes, and standards.

Additionally, both renewable generation and water electrolysis use power electronics, which convert the AC grid or other power source to a DC source with the desired voltage. Today, power electronics are generally custom-built devices that may account for up to 30% of system cost. For example, a wind turbine produces AC electricity at a frequency dependent on wind speed. This "wild" AC current is converted to grid frequency (60 hertz [Hz]) by power electronics at the turbine. The electrolysis system then converts this AC current to DC power.

Capital Costs

Capital costs for current electrolyzer technologies are a barrier to attaining the targeted hydrogen production cost. High capital costs are caused by expensive materials, relatively small systems, relatively

⁷² Office of Energy Efficiency and Renewable Energy, *Fuel Cell Technologies Office Multi-Year Research, Development, and Demonstration Plan* (Washington, DC: U.S. Department of Energy, November 2012), Section 3.1, www1.eere.energy.gov/hydrogenandfuelcells/mypp/.

low efficiencies, customized power electronics and other BOP components, and labor-intensive fabrication.

The high costs of noble metals and the lack of durability drive up electrode and membrane costs. Current production rates are below targeted levels, and systems are incapable of efficiently operating at the high current densities that would allow decreased stack size. Cell and stack architecture is often too complex and does not have a long enough life span. Generally, production volume is insufficient to meet projected future demand. Custom-built power electronics and other BOP components also contribute to increased capital costs. Higher-temperature systems need low-cost thermal management (e.g., vaporizers, recuperators).

Manufacturing

Electrolysis units are currently produced in low volume. Mass production is capital-intensive, and manufacturers must therefore have assurance that the product demand will be high enough to enable adequate return on investment. The industry believes that manufacturing techniques can progress sequentially from hand processes to low-volume, semi-automated, automated, and finally high-volume automated processes, similar to automotive manufacturing, at unit demands of 10; 100; 1,000; and 10,000 units per year, respectively.⁷³ A step change in cost is anticipated for each change in manufacturing technique. Currently, low-volume manufacturers have little leverage to obtain lower costs or preferred materials from suppliers. For example, solid oxide electrolyzers require stainless steel manifolds and interconnects. The optimal thickness of the steel is not a standard size, and to get the desired thickness would require a steel run of approximately 70,000 pounds. At low-volume production, manufacturers would be forced to pay extra for the steel or use plates that are of less than optimal thickness. Site-specific fabrication drives up manufacturing costs of crucial system components and of BOP components, and often results in systems that are larger than necessary.

Operations and Maintenance

O&M costs for distributed hydrogen production from water electrolysis are too high. Diverse barriers need to be addressed to achieve the stated DOE targets. For distributed production, some of the O&M issues related to durability, scheduled maintenance, and demand management are nearly identical to those for DNGR systems (see Section 1.2). Central hydrogen production entails O&M costs, and even though the specific needs and constraints may vary from the distributed case, the themes are similar. All system components must be considered in O&M, including power conditioning/management, feed pre-conditioning (e.g., water purification), controls, utilities, QA/QC (e.g., sensors), compression, storage, dispensing, and safety.

Efficiency. The major cost during operation is electricity, so the efficiency of the electrolysis system (stack, BOP, power conditioning/management, etc.) is crucial. However, there are trade-offs between efficiency and capital cost. The stacks could be operated at extremely high efficiencies, but to achieve the desired production rates, larger stacks (increased capital cost) would be required. Technoeconomic analysis can be used to help determine the projected optimal balance between efficiency and capital costs.

Durability. High-temperature stacks require improved materials that are inexpensive, efficient, and highly resistant to corrosion. In addition, high-temperature seals must be able to operate at moderate pressures and withstand thermal cycling.

Transients and Duty Cycles. For central wind and distributed production cases, water electrolysis units will not be operated at constant levels because of variations in power (wind) or

⁷³ Interview with the U.S. Department of Energy Water Electrolysis Group Industry Experts, February 28, 2008.

fluctuating demand (distributed). Water electrolysis systems face major challenges in achieving efficient operation over a wide range of conditions.

Water Purification. Water electrolysis requires a pure water stream. This purity is typically achieved through reverse osmosis, deionization filters, or other pretreatment. The technologies involved are mature and used in a variety of fields. Cost and durability of the units must be considered along with ease of operation.

Grid Electricity Emissions

The most likely initial introduction of water electrolysis will be in distributed hydrogen generation stations using the existing electric grid. As noted previously, the current grid mix in most locations generates greenhouse and other gas emissions. The GHG emissions will naturally become reduced as the grid incorporates more renewable energy.

Control and Safety

Control and safety barriers associated with water electrolysis include the efficiency of start-up and shut-down processes, turn-down capability, and the capability for rapid on-off cycling. Control and safety system costs remain high owing to complex system designs and multiple high-cost, necessary sensors. Currently available sensors are too expensive and insufficiently reliable. For distributed production, the permitting process critically relies on the proven reliability and safety of these units, which are a key qualification target. These units must be designed to operate in an environment of no manual assistance, which will require attributes such as back-up/fail-safe mode, remote monitoring, and sparse maintenance schedules. Centralized production will require development of new control and safety procedures. This is particularly true for central generation using nuclear power. Key questions need to be answered, such as how close the hydrogen generation facilities should be to the nuclear generator and how close the hydrogen pipeline should be to the nuclear reactors.

4.3 Strategy to Overcome Barriers and Achieve Technical Targets

Table 4.3 lists critical technology needs for water electrolysis hydrogen production. Discussion of these efforts follows. Note that a single R&D activity may address more than one barrier or multiple R&D activities may be needed to address a single barrier.

Table 4.3. Water Electrolysis — Critical Technology Needs

Reduce Capital Costs	<ul style="list-style-type: none"> ➔ Materials ➔ Improved catalysts ➔ Architecture ➔ Balance of plant ➔ System optimization to manage variable demands ➔ DFMA/high-volume equipment manufacturing
Reduce Operations and Maintenance Costs	<ul style="list-style-type: none"> ➔ Automated process control ➔ Reliability ➔ Improved system efficiency ➔ H₂ quality control/hydrogen drying ➔ Water conditioning ➔ Capital utilization

Meeting the foregoing challenges and achieving the commercialization DOE cost targets for hydrogen production from water electrolysis will require diverse R&D efforts as well as the development of policies and standards. Many nuclear facilities currently have hydrogen safety protocols that may be

adapted for production. In addition, standardizing certifications, codes, and standards will minimize control and safety concerns. Technology improvements must be developed in the context of a stringent regulatory environment, limited physical space, and resource limitations.

The cost of producing hydrogen from water electrolysis is largely determined by the electricity cost and, to a lesser extent, capital equipment costs. Thus, improved system efficiency and reduction of capital cost are the primary technology needs. For distributed installations, the FCT Office's MYRD&D sets the target for "Electrolysis System Capital Cost Contribution" in 2015 to \$0.50 per gge (to achieve the \$3.90 gge DOE cost target for hydrogen production). For central hydrogen electrolysis units, the capital costs are \$0.50 per gge to achieve \$3.00 gge (plant gate) in 2015, and \$0.40 per gge to achieve \$2.00 gge in 2020.⁷⁴

Reduce Capital Costs

Currently, significant research efforts are directed toward developing new and improved materials, increasing stack and system efficiency, reducing part count, improving electrodes, and integrating with renewable power. Advances have been achieved in all of these areas, and additional efforts are needed to facilitate mass production of equipment and development of materials that are lower-cost, easier to manufacture, and more durable. Also, with the reduction in electrolyzer stack costs achieved over the last several years, the cost contribution from BOP components has become more significant.

Materials. The materials cost discussion is divided into improvements needed in low-temperature systems (PEM and alkaline) and in high-temperature systems (solid oxide).

Low-temperature water electrolysis units need improved materials in several areas: membranes, membrane electrode assembly (MEA) bi-polar plates, frames/support structures, and seals. Membranes tend to be expensive and/or require expensive processing techniques; development work is needed for membranes that are inexpensive, easy to manufacture, and easy to process. The membranes' ionic conductivity needs to improve to decrease the ohmic overpotential. This would result in higher efficiency or higher electric current capability, depending on how the stack is operated. Operation at higher temperatures may increase system efficiency. Finally, the membranes should be more durable. Less expensive, more durable materials that are easier to process would help to lower costs.

Alkaline electrolyzer cells need materials with improved CO₂ tolerance. In alkaline systems, CO₂ reacts with the electrolyte potassium hydroxide (KOH) to form carbonates, which have a number of undesirable effects on the cell. Carbon dioxide scrubbers and/or gas diffusion layers need to be improved to inhibit CO₂ from gaining access to the electrolyte. New inexpensive materials are needed to decrease the cost of the frames and electrode support structures. This is particularly important to enable systems to operate at elevated pressures.

Current electrolysis units typically produce hydrogen at 100 to 300 psig. Development of systems capable of operating at higher pressures would decrease the capital and operational costs for compressors. Materials that can tolerate operation at higher pressures need to be developed. Membrane materials with lower hydrogen crossover at elevated pressures and improved seals to enable high-pressure, long-life operation are needed.

High-temperature solid oxide electrolyzer systems have materials needs similar to their lower-temperature counterparts; however, there are enough differences to warrant a separate discussion. High-temperature

⁷⁴ Office of Energy Efficiency and Renewable Energy, *Fuel Cell Technologies Office Multi-Year Research, Development, and Demonstration Plan* (Washington, DC: U.S. Department of Energy, November 2012), Section 3.1, www1.eere.energy.gov/hydrogenandfuelcells/myrpp/.

systems now operate at 750° to 850°C and use a solid oxide electrolyte rather than the organic separator found in low-temperature (<150°C) systems. The cost of the system could be decreased if inexpensive, durable electrolytes could be developed to offer higher ionic conductivity at lower operating temperatures of 550° to 700°C. These electrolytes need to be able to operate for long periods of time and withstand occasional thermal cycles without promoting de-lamination of the electrodes from the electrolyte. Interconnects need development to improve their corrosion resistance and increase their useful lives. Current solid oxide electrolyzer stacks have issues with manifold scaling and corrosion due to the high-temperature steam used in the systems. Materials with improved corrosion resistance are needed to enable long-life operation. Finally, high-temperature steam tends to pull chrome from the steel tubes and interconnects that are often used in these systems. The chrome can deposit onto the electrodes, poisoning them. Coatings, filters, and/or improved catalysts need to be developed to prevent the chromium from migrating from the steel tubes to the electrodes.

For both low- and high-temperature technologies, detailed models are needed to aid in stack and system scaling. Finally, advances in fuel cell development should be monitored and applied, as appropriate, focusing on work by EERE's Fuel Cell Technologies Office and FE's Solid State Energy Conversion Alliance (SECA) program.

Improved Catalysts. Although the catalysts vary, the needs are the same for high- and low-temperature systems. Electrodes need improved catalyst durability and activity at lower cost. For the solid oxide and alkaline electrolyzers that currently use low-cost electrodes (typically nickel or lanthanides), catalyst activity and durability could be improved with novel deposition techniques, nano-catalysts, or improved supports. For PEM electrolysis cells, electrocatalysts with reduced precious metal loadings or non-precious metal catalysts with high activity and durability would decrease overall capital costs.

Architecture. Current water electrolysis units have relatively low hydrogen production rates (typically 100 kg/day or less). These units need to be scaled up, particularly to achieve the massive production rates required in central production (>50,000 kg/day). Novel stack architectures may be required to maintain low cost. These architectures will need the following characteristics:

- Large cell area
- Low-cost support structures
- Oxidation/corrosion resistance
- Durable seals
- Low-pressure drop flow fields
- High-pressure operation
- Ability to operate at appropriate temperatures for long life
- Even gas flow distribution
- Appropriate electric current distribution
- Reduced part count
- Amenability to low-cost, high-volume manufacturing.

Combining water electrolysis with electrochemical compression in a single stack to deliver pressurized hydrogen is of interest. This integration will require stacks to be designed to operate at these higher pressures. Further analysis is needed to determine whether there is an optimal trade-off between additional costs associated with a pressurized electrolysis stack versus savings obtained by decreasing compression and hydrogen drying costs. It is believed that operating the stack at 300 to 1,000 psi could decrease compressor and hydrogen drying costs with minimal impact on stack costs.

For solid oxide electrolyzer-based technologies, the following characteristics are also needed:

- Good coefficient of thermal expansion (CTE) match among the various cell/stack components for higher-temperature operation

- Chromium migration mitigation
- Uniform stack temperature distribution.

Balance of Plant. With recent advances in increasing the electrolysis stack efficiency and durability while reducing its cost, the BOP components now have a more substantial impact on the overall capital costs. Improved low-cost sensors, pumps, water purification systems, hydrogen dryers, power conditioning, and monitoring equipment need to be developed. Equipment specific to the requirements of water electrolysis needs to be designed and manufactured in high enough volumes to decrease costs. Durability of these components is another important parameter that has a direct impact on capital and operating costs.

System Optimization to Manage Variable Demands. For distributed hydrogen production, demand for hydrogen refueling will vary significantly over the course of a day. This variable demand may be handled through a combination of on-site hydrogen storage and load-responsive capability in the water electrolysis system. The use of storage versus load-response capability to handle variability will significantly affect capital cost, electrolyzer system utilization, service station footprint, and cost at the pump. In some cases, reduced electricity rates may be negotiated by operating primarily during off-peak times. This may make it more economical to have larger storage tanks compared to other distributed hydrogen technologies. Optimizing the balance between storage and production rate capacity must also consider the relative impacts on maintenance costs and safety.

In some central wind scenarios, the hydrogen production rate will vary significantly. The water electrolysis system will need to be able to operate over a wide range of conditions with high efficiency. In addition, suitable power electronics will need to be developed to enable efficient power conversion.

DFMA/High-Volume Equipment Manufacturing. DFMA will be a key component of cost reduction efforts for water electrolysis units, both for near-term, semi-custom installations, and for longer-term, higher-volume manufacturing. In the near term, in light of limited production volumes, DFMA should be focused on developing water electrolysis designs that incorporate commonly available (commodity) materials and use common tooling and available standard sizing of procured components (such as tubing, driers, and power electronic components). Design for modularity will be especially important for semi-custom installations. Modular design will allow improvements in specific subsystems to be incorporated without redesigning the entire process. Flexible, modular design will also allow scalable systems, thereby increasing the application domain and overall production volumes. Other critical technology needs in DFMA for water electrolysis are the same as those discussed in the DNGR section.

Reduce Operations and Maintenance Costs

O&M costs produce a significant impact on the overall cost of producing hydrogen. In fact, electricity costs are, by far, the largest contributor to the cost of producing hydrogen via water electrolysis. Electricity costs can be decreased by increasing system efficiency and negotiating lower rates with the electric utility (e.g., by agreeing to operate the electrolyzer system primarily during off-peak hours). O&M costs may also be reduced through improved process design and technologies that increase energy efficiency, including improved process controls for cycle optimization, better and less expensive sensors, and better turn-down capability.

Automated Process Control. Planned maintenance must be minimized in terms of both cost and frequency. For distributed hydrogen production, on-site labor should be reduced through the use of automated process control and remote monitoring, including automatic fault detection. For central hydrogen production, automated process control with limited monitoring will reduce the on-site labor support but is not as crucial as in the distributed case.

Reliability. Equipment reliability (especially pumps, compressors, blowers, and power supplies) is often a limiting factor in the overall system reliability. Increasing the reliability of these components, along with minimizing equipment complexity, is critical for improving system reliability. For water electrolysis systems, sustained catalyst activity is important for reliable and efficient operation. Impurities in water must be controlled to protect water electrolysis components.

Improved System Efficiency. The more extensive discussion of improving system efficiency presented earlier as a way to reduce capital costs is essentially applicable to reducing O&M costs as well. Additionally, minimizing material and energy losses will improve the overall system efficiency for converting water and electricity into hydrogen. Hydrogen leakage must be virtually eliminated to minimize loss of process efficiency as well as for safety. Heat loss and heat rejection must also be minimized through well-designed insulation and heat integration.

Hydrogen Quality Control/Hydrogen Drying. Requirements on the quality of hydrogen for use in fuel cell vehicles are becoming increasingly stringent, and incumbent technologies need to satisfy these requirements. (Current hydrogen quality specifications are available through SAE TIR J2719.) Strict quality requirements also introduce the need for low-cost support and equipment to conduct quality control. Standard test methods need to be developed and made readily available to detect some of the contaminant species at the prescribed level. For water electrolysis technologies, the primary contaminant is water. The most popular dryer technologies include adsorption techniques and membrane dryers, both of which decrease efficiency. Each technology has its advantages and disadvantages. More efficient methods are needed to dry the hydrogen with little or no hydrogen loss.

Water Conditioning. High-purity water is required for long-life water electrolysis operation. Municipal water needs to have contaminants removed, typically by reverse osmosis or similar purification systems, to achieve a resistivity of less than 2 kilohm-cm ($k\Omega\text{-cm}$) for alkaline electrolyzers or 1 to 5 $M\Omega\text{-cm}$ (ASTM Specification 2) for PEM and solid oxide electrolyzers. Efficient conditioning systems need to be developed. Unused water from the water electrolysis could then be recycled to decrease water conditioning costs.

Capital Utilization. Electrolyzer systems require less maintenance if operated at constant load. Peaks and valleys in hydrogen demand for vehicles must be leveled to maximize capital utilization and decrease maintenance costs. Water electrolysis unit size must be balanced with an appropriate hydrogen storage system. Increased utilization may also be accomplished by finding alternate uses for the hydrogen or generating revenue from co-produced products. This is particularly important for the central production cases, in which electricity can be sold as co-product.

5.0 Solar Thermochemical Hydrogen

The solar thermochemical hydrogen (STCH) pathway calls for producing hydrogen in semi-central and central facilities via high-temperature thermochemical water splitting powered by concentrated sunlight. STCH offers a potential technology for clean, sustainable hydrogen production.

5.1 Current Status and Technical Targets

Solar thermochemical pathways use only water, heat from concentrated sunlight, and chemicals that are recycled. Only hydrogen and oxygen are produced, with water and solar thermal energy as the primary inputs. Thermochemical cycles have also been investigated under the DOE-NE Nuclear Hydrogen Initiative (NHI) using nuclear energy as the heat source. This roadmap focuses on solar-powered STCH pathways. (The NHI strategy for developing nuclear hydrogen production under the Next Generation Nuclear Plant project within NE is described in a separate document.)⁷⁵

STCH is at a relatively early stage of development, requiring additional fundamental and applied R&D. Most of the chemical cycles for this application were identified from the 1960s through the early 1980s, after which much research in this area discontinued.⁷⁶ Renewed interest in the early 2000s can in part be explained by the rapid pace of development of concentrated solar power (CSP) technologies whose high temperatures are ideal for STCH hydrogen-production processes.⁷⁷ As with all solar hydrogen technologies, large-scale STCH hydrogen production will require large areas for collecting sufficient sunlight, with the associated levels of land and capital costs. Maximizing conversion efficiency to reduce the solar collectors' overall footprint remains critical to cost reduction. Thermal management, including recuperation, storage and possible backup power, is also important to the success of STCH technologies.

Solar Thermochemical Hydrogen Technology

Numerous solar thermochemical water-splitting cycles have been investigated for hydrogen production,⁷⁸ each with different sets of operating conditions, engineering challenges, and hydrogen production opportunities. In fact, more than 300 water-splitting cycles are described in the literature;⁷⁹ continued R&D is needed to identify and develop the most promising.

Solar Thermochemical Production

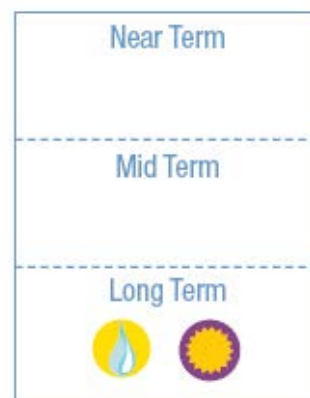

Feedstock:	Water
Energy Source:	Solar
Production:	Semi-Central Central

Environmental Benefits

Thermochemical hydrogen production offers a potential route to clean, sustainable hydrogen production. It uses only water, heat, and chemicals that are recycled. When the heat comes from the sun, only hydrogen and oxygen are produced and only water and solar thermal energy are consumed.

⁷⁵ Office of Nuclear Energy, "Nuclear Hydrogen R&D Plan" (Washington, DC: U.S. Department of Energy, 2004), http://www.hydrogen.energy.gov/pdfs/nuclear_energy_h2_plan.pdf.

⁷⁶ M. Lewis, M. Serban, J. Basco, and J. Figueroa, "Low Temperature Thermochemical Cycle Development," prepared for Argonne National Laboratory (presentation to the Organisation for Economic Co-operation and Development's Nuclear Energy Agency, October 2–3, 2003).

⁷⁷ A. Steinfeld, "Solar thermochemical production of hydrogen – a review," *Solar Energy* 78 (2005): 603–615.

⁷⁸ R. Perret, *Solar Thermochemical Hydrogen Production Research (STCH)*, SAND2011-3622 (Albuquerque, NM: Sandia National Laboratories, 2011), http://www1.eere.energy.gov/hydrogenandfuelcells/pdfs/solar_thermo_h2.pdf.

⁷⁹ Ibid.

Broadly, the STCH processes can be divided into “direct” cycles, which use only the concentrated solar thermal energy, and “hybrid” cycles, which additionally incorporate an electricity-driven electrolysis step as part of the water-splitting cycle. Typically, the direct thermal cycles offer lower complexity but require higher operating temperatures. With the energy added to the electrolysis step in hybrid cycles (typically less energy-consumptive than direct water-splitting electrolysis), these cycles can operate at lower temperatures, which offers practical advantages for reactor design and durability. Disadvantages of the hybrid systems include added complexity and extra requirement for electric input (which perhaps could be generated on site using waste heat from the STCH reactor). Examples of direct thermal and hybrid STCH cycles are, respectively, the simple two-step cerium oxide thermal cycle and the hybrid copper chloride cycles, as shown in Figure 5.1.

The high temperatures necessary to split water via the STCH processes require the use of concentrated solar power. One approach is the deployment of a central STCH reactor in a solar receiver tower surrounded by heliostat fields (fields of sun-tracking mirrors) of a suitable size. Another approach is the use of multiple smaller-scale STCH reactor modules, each coupled to a tracking dish concentrator. Both approaches are illustrated in Figure 5.2. Each approach has unique advantages and disadvantages; however, both can incur significant capital expense because of the solar resource’s diffuse nature, requiring large areas and infrastructure for efficient collection and concentration.⁸⁰

Independent of the solar concentration approach, all known STCH cycles face obstacles that include high-temperature operations, highly corrosive chemicals, difficult separations of chemicals during sequential cycle steps, multiple reaction steps necessary to close the cycle, or side reactions with stable products that poison the process upon recycling. Many of these barriers can be overcome, but generally at the expense of energy efficiency, consumption of feedstocks other than water (e.g., electricity in the hybrid cycles), and possibly extremely high temperatures to drive reactions to completion. All of these measures add cost to the product, inhibit acceptable production rates, or prevent the realization of plant designs with acceptable lifetimes.

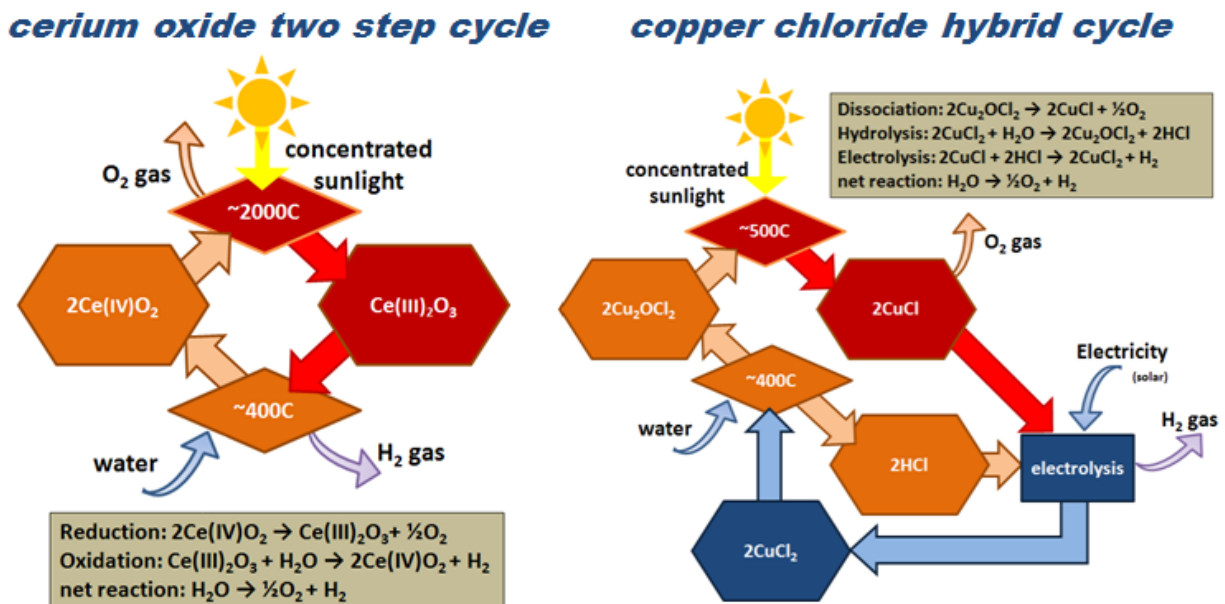

Figure 5.1. Examples of Solar Thermochemical Cycles for Hydrogen Production

⁸⁰ Sandia National Laboratories, “Concentrating Solar Power (CSP),” U.S. Department of Energy, http://energy.sandia.gov/?page_id=2445.

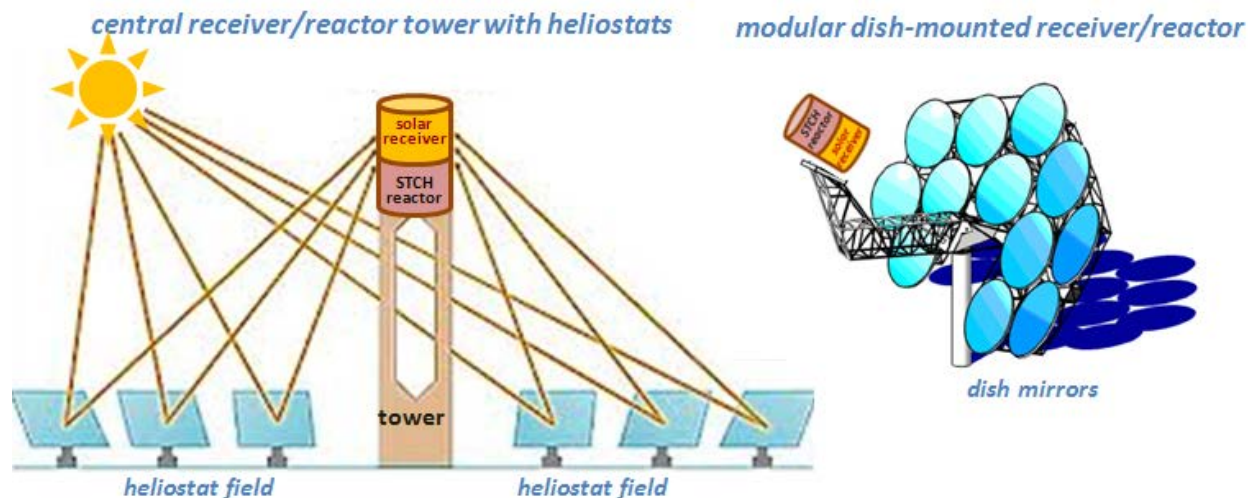

Figure 5.2. Tower and Dish-Mount STCH Receiver-Reactor Configurations

With solar radiation as the driving energy source, overcoming these barriers is made even more difficult, primarily because of the source's transient nature and relatively low power density. The low power density characteristic of solar power requires large collector areas and efficient concentrators to drive energy-intensive processes such as water splitting. Additionally, reactors must endure daily cycling from low to high temperatures resulting from the sun's day/night cycles, as well as weather effects. One option is decreasing reactor cycling by storing the thermal energy in salts or other materials to enable continuous production. A combination of thermal storage and/or backup power might be needed to ensure continuous operation.

Ultimately, the success of solar thermochemical hydrogen production is contingent on developing suitable reactive materials, on incorporating these materials into an efficient solar thermochemical reactor, and on integration into cost-effective solar collection and concentration technologies. Current research priorities focus on the identification and characterization of the most promising thermochemical cycles and associated reactive materials. Additional R&D efforts are being directed at reactor design and system-level challenges related to solar water splitting based on the most promising cycles compatible with the necessary production capacities, solar-to-hydrogen conversion efficiencies, and hydrogen production costs.

The DOE MYRD&D indicates that STCH solar-to-hydrogen (STH) efficiencies >25% may be needed in order to ultimately reach the hydrogen cost threshold goal. In this context, the STH efficiency is defined as:

$$\frac{\text{energy of the net hydrogen produced (based on the lower heating value of H}_2\text{)}}{\text{solar energy consumed at the STCH facility}} \quad (1)$$

For systems utilizing solar energy input only, the consumed energy is calculated based on the incident irradiance over the total area of the solar collector. For hybrid systems, all additional non-solar energy sources (e.g., electricity for the electrolysis step) must be included in the denominator as equivalent solar energy inputs (for example, the solar energy needed to supply electricity via CSP). Recent analysis has

indicated that STCH reactor systems have the potential to exceed 20% STH (for a cerium oxide cycle, assuming thermal-to-chemical conversion efficiencies of 37% can be achieved).⁸¹ However, bench-scale demonstrations of full-cycle STCH solar hydrogen production to date have been limited to <5% STH owing to materials, receiver and reactor losses.⁸²

DOE Cost Targets

Making STCH technically viable will require long-term, high-risk research. The technology is not expected to meet DOE's cost targets in the next 10 years; however, the potential opportunity to harvest such tremendously clean energy makes this risk acceptable at this time. The DOE MYRD&D details the fundamental and engineering technical barriers and strategies for overcoming these barriers for STCH solar hydrogen production. The specific short-term and longer-term hydrogen cost goals for the STCH pathway, taken directly from the DOE MYRD&D, are shown in Table 5.1.⁸³

Table 5.1. Solar-Driven High-Temperature Thermochemical Hydrogen Production — DOE Cost Targets⁸⁴

Target Year	Production Scale	Cost/gge (produced)
2015	Semi-central/Central	\$14.80
2020	Semi-central/Central	\$3.70

5.2 Gaps and Technical Barriers

DOE's research activities are being driven by specific barriers identified in the MYRD&D, as well as others identified by the U.S. DRIVE Partnership's HPTT. These are summarized in Table 5.2 and described on the following pages.

⁸¹ N. Siegal, "Solar Hydrogen Production with a Metal Oxide-Based Thermochemical Cycle," in *U.S. Department of Energy Hydrogen and Fuel Cells Program FY 2011 Annual Progress Report* (Washington, DC: U.S. Department of Energy, 2011), http://www.hydrogen.energy.gov/pdfs/progress11/ii_f_3_siegel_2011.pdf.

⁸² W. Chueh, C. Falter, M. Abbott, D. Scipio, P. Furler, S. Haile, and A. Steinfeld, "High-Flux Solar-Driven Thermochemical Dissociation of CO₂ and H₂O Using Nonstoichiometric Ceria," *Science* 330 (2010): 1797–1801.

⁸³ Office of Energy Efficiency and Renewable Energy, *Fuel Cell Technologies Office Multi-Year Research, Development, and Demonstration Plan* (Washington, DC: U.S. Department of Energy, November 2012), Section 3.1, www1.eere.energy.gov/hydrogenandfuelcells/mypp/.

⁸⁴ Ibid.

Table 5.2. Solar Thermochemical Hydrogen — Summary of Barriers

Thermochemical Cycle Selection Challenge	Cycle Prioritization: Significant and sustained resources are needed to fully characterize closed-loop viability of promising thermochemical cycles. Continued detailed technoeconomic analysis and cycles research are needed to identify leading technologies for further system engineering development.
Challenges in Materials Development	Reactant Materials: Many thermochemical cycles require reaction temperatures in excess of 1000°C. Reactant and catalyst materials for many of the promising cycles are insufficiently developed to handle the required temperatures. Critical parameters of these materials include physical and chemical stability, thermal compatibility, efficient heat transfer and fast kinetics, and sufficiently low cost.
	Reactor Materials: Materials for the receiver–reactor, seals, catalysts, supports, etc., are insufficiently developed to handle the thermal cycles and required temperatures, which in many cases exceed 1000°C. Critical parameters of these materials are chemical stability and thermal compatibility, as well as low cost.
	Electrolyzer Materials (Hybrid Cycles): Materials for the electrolyzers in hybrid STCH cycles are insufficiently developed. These materials include membranes, catalysts and support structures. Important materials parameters require optimization to achieve low-voltage/high-efficiency operations as well as long operational lifetimes with minimum contamination and/or cross-over degradation.
Challenges in Thermochemical Reactor Development	Cost-Effective Cycle-Specific Reactor Designs: Different cycles have different reactor requirements. Current reactors are inefficient and costly, and they require excessive BOP components. Innovative, non-conventional reactors may be required for meeting cost goals. Scalability limits for reactors need to be defined. Thermal cycling requirements must be addressed in the reactor design.
	Thermal Management: High efficiency in any thermochemical reactor design will require improved levels of thermal management and heat recuperation.
	Reactant Transport: Reactant materials need to be managed and transported efficiently between steps in any given STCH cycle to minimize losses and improve overall efficiency.
	Phase Separation: Some of the promising STCH cycles will require improved phase separation during certain reaction steps to reduce losses and improve efficiency. Included can be the separation and purification of the product hydrogen gas.
	Electrolyzer Optimization (Hybrid Cycles): Efficiency of the electrolysis step in hybrid cycles needs to be optimized in terms of low operating voltage, minimal membrane crossover loss, long lifetime and efficient reactant/product management to reduce overall system losses.
Challenges in Solar Receiver Development	Efficient Solar Collection: The receiver is the focal point of the solar concentrator that directs thermal power to the reactor and/or thermal storage. Thermal losses, particularly re-radiation losses, remain a barrier.
	Interface to Thermochemical Reactor: Interfaces coupling the receiver to the thermochemical reactor need to be developed and optimized.
Intermittency of Solar Resource	Thermal/Chemical Storage and/or Backup Power: Storage materials and technologies needed for continuous operations remain technically challenging and costly. A combination of thermal storage and/or backup power might be needed to ensure continuous operation.
Cost of Solar Concentrator Technologies	Concentrator Costs: Current solar concentration technologies, including heliostats and dishes, require improvements in efficiency and lifetime, and significant reductions in cost.

Table 5.2. (Cont.)

Operations Costs	Operations and Maintenance: O&M costs are expected to be high; current system designs will require intense, on-site maintenance that is costly.
	Control and Safety: Specific safety issues must be addressed for the use of hazardous materials and chemicals associated with some thermochemical cycles (including storage systems).
	24/7 Operation: Solar power fluctuations will strongly influence the design, performance, and economic viability of this technology. Systems should be developed to produce hydrogen during off- or low-sun conditions.
Land and Capital Costs	Land Area Requirements: Commercial-scale STCH hydrogen production will require large areas for collecting sufficient sunlight, with the associated land costs.
	Capital Costs: A large-scale STCH facility will require substantial capital cost in solar collectors, receiver–reactors and BOP.

Thermochemical Cycle Selection

The literature has over 300 thermochemical cycle candidates, and new cycles continue to emerge. The most promising cycles need to be identified for further development. The complete set of criteria for selection, described in recent publications,⁸⁵ include thermal efficiency, operation temperature (lower temperatures are desired), minimal numbers of steps, and low raw materials costs, among others. In order to achieve the DOE MYRD&D targets, the projected thermal-to-chemical efficiency will need to exceed 35%, and the complete solar-to-hydrogen efficiency will need to exceed 25%. The DOE Hydrogen and Fuel Cells Program has already reduced the initial list of 300 cycles to approximately 25 based on the above listed requirements. From the results of the continued technoeconomic evaluations,⁸⁶ the most promising cycles from the current list of 25 will be identified for further R&D.

Materials Development

The solar thermochemical cycles require high reaction temperatures, sometimes in excess of 1500°C for the high-temperature reaction step. Many of the materials for the reactants, reactor, seals, catalysts, and supports do not possess adequate thermal, physical, or chemical stability at these temperatures and rapid temperature transients. Thermal compatibility in reactor components, seals, etc., can also be problematic considering the wide temperature swings entailed by STCH. Reactant materials need to be developed not only with sufficient thermal and chemical stability but also with optimized heat exchange and surface kinetics for efficient thermal-to-chemical conversion efficiency.

Materials must endure extreme heat and corrosive and reactive environments, posing major challenges for development of durable, inexpensive materials for reactants, reactor, receiver, and any included thermal/chemical storage. Moreover, these materials would have to be easy to manufacture and capable of enduring extreme thermal shock. Some of the chemical cycles may require catalysts and/or supports, which will also need to endure aggressive environments. The materials will need to endure daily cycles

⁸⁵ R. Perret, *Solar Thermochemical Hydrogen Production Research (STCH)*, SAND2011-3622 (Albuquerque, NM: Sandia National Laboratories, 2011), http://www1.eere.energy.gov/hydrogenandfuelcells/pdfs/solar_thermo_h2.pdf.

⁸⁶ R. Perret, *Solar Thermochemical Hydrogen Production Research (STCH)*, SAND2011-3622 (Albuquerque, NM: Sandia National Laboratories, 2011), http://www1.eere.energy.gov/hydrogenandfuelcells/pdfs/solar_thermo_h2.pdf; M. Kromer, et al., *Support for Cost Analyses on Solar-Driven High Temperature Thermochemical Water-Splitting Cycles*, produced by TIAX LLC, Lexington, MA (Washington, DC: U.S. Department of Energy, Feb. 22, 2011), http://www1.eere.energy.gov/hydrogenandfuelcells/pdfs/solar_thermo_h2_cost.pdf.

and severe thermal temperature cycling. Ceramics that can endure high temperatures have issues with the cycling and with seals. Metals, such as Hastelloy steel, have better cycle life and fewer seal issues but have a lower usable temperature.

Hybrid STCH cycles also require materials R&D for major components of the electrolysis step. These materials include membranes, catalysts and support structures. Important materials parameters require optimization to achieve low-voltage–high-efficiency operations as well as long operational lifetimes with minimum contamination and/or cross-over degradation and materials durability.

Chemical Reactor Development

At the hydrogen production scales of interest, STCH chemical plants are expected to be capital-intensive. STCH chemical reactor designs need to be efficient and inexpensive and to entail minimal BOP to meet the DOE cost targets. While a number of reactor types have been proposed for the STCH cycles, certain cycles will require specialized reactors, such as the rotating disk reactor, fluid wall reactor, and centrifugal reactor. In some cases, more conventional designs may be applicable.

High-temperature operation necessitates extreme thermal management to achieve high efficiencies. Thermal losses result from inefficient process flow and a lack of integration among unit operations. Heat recuperation is vital to attaining the conversion efficiencies required to meet hydrogen cost threshold goals.

Other barriers to reactor development and capital costs include cycle phase separation and purification, including the extraction of sufficiently pure hydrogen product. Ideally, the product stream will be composed of only hydrogen and water. However, there may be small amounts of other contaminants similar to those in hydrogen produced via water electrolysis. In hybrid cycles, efficiency of the electrolysis step needs to be optimized in terms of low voltage, high efficiency, long lifetime and efficient reactant/product management to reduce overall system losses.

Solar Receiver Development

STCH reactors can be broadly classified as directly heated by the sun or indirectly heated (e.g., a thermal transfer medium absorbs the thermal energy and transfers the energy to the reactor). The solar receiver is the focal point of the solar concentrator (e.g., heliostat field or dish concentrators) and directs the thermal power to the reactor and/or thermal storage. Efficient heat transfer at the interface with the heliostat remains a barrier as the cycles move toward commercialization.

The interface with the chemical reactor is an important consideration in selecting a solar receiver. For directly heated reactors (e.g., rotating disk, fluid wall, and centrifugal), the receiver and reactor are integrated, enabling solar flux to heat the reactor. Ideally, the solar thermal input rate would match the heat of reaction at constant temperature. However, the chemistry and dynamics of each system establish the equilibrium temperature required.

The solid particle and volumetric receivers are heated indirectly by the sun. For these reactors, the heat is absorbed by solid particles (e.g., sand) or molten salts, which then heat the reactors. Heat addition is, therefore, not isothermal. In addition, the amount of energy transferred to the thermochemical reaction from the intermediate heat transfer media depends on the range of temperature absorbed by the chemical reaction. The non-isothermal nature of these receivers may be suitable for cycles with steps requiring different temperatures. In addition to interfacing with the receiver, the reactor must also interface with thermal storage, if used.

Solar Intermittency

Cost-effective solar-driven hydrogen production requires that cycles incorporate either thermal/ chemical storage or some form of backup power to enable time-shifted hydrogen production to compensate for intermittent solar energy input; however, the appropriate materials or processes have yet to be identified or developed. Storage or backup power can enable continuous plant operations, which will extend the operational lifetime of the STCH reactor. However, this will add cost to the receiver–reactor interface. In addition, insulated storage sites and increased BOP components would be required, adding to the capital and O&M costs. Any storage or backup power approaches will need to be thermally efficient, inexpensive, and chemically compatible with the STCH process. Some thermal storage material options include molten nitrate salts, molten carbonate salts and molten metals, each with different advantages and challenges in terms of operating temperatures and safety.

Solar Concentrator Technologies

The solar concentrator (e.g., the heliostat field or dish concentrators) is a key unit in the development of STCH production. Currently, the units are too expensive, and development is needed to reduce their cost. High costs are in part due to a lack of standardization in their designs, as well as inefficient manufacturing and poor durability. Leveraging R&D efforts (for example, the DOE SunShot Program)⁸⁷ is expected to be critical in developing more cost-effective solar concentrator technologies (for solar electricity, solar fuels, and solar hydrogen).

Operations Costs

All system components must be considered in O&M costs, including feed pre-conditioning, solar concentrators, solar receivers, reactor, hydrogen purification, controls, utilities, QA/QC (e.g., sensors), compression, storage, and safety. Control/safety system costs may remain high because of system complexity and/or substantial sensor count to assure reliability. These units must operate in an environment of minimal manual assistance, which will require attributes such as back-up fail-safe mode, remote monitoring, and sparse maintenance schedules. Solar power availability and fluctuations will strongly influence the design, performance, and economic viability of this technology. The capital and O&M costs of a STCH facility, including thermal/chemical storage for 24/7 operations, may affect the cost-competitiveness of this technology.

Land and Capital Costs

As with all solar hydrogen technologies, large-scale STCH hydrogen production will require large areas for collecting sufficient sunlight, with the associated levels of land and capital costs. Maximizing conversion efficiency to reduce the solar collectors' overall footprint remains critical to cost reduction. Reducing capital costs in the receiver–reactor components and in all BOP components is also necessary.

5.3 Strategy to Overcome Barriers and Achieve Technical Targets

Table 5.3 lists critical technology needs for STCH production. A discussion of these efforts follows. Note that a single R&D activity may address more than one barrier, or multiple R&D activities may be needed to address a single barrier.

⁸⁷ U.S. Department of Energy, *SunShot Vision Study* (Washington, DC: U.S. Department of Energy, 2012), http://www1.eere.energy.gov/solar/pdfs/47927_executive_summary.pdf.

Table 5.3. Solar Thermochemical Hydrogen — Critical Technology Needs in Promising Cycles

Improved Reactant Materials	<ul style="list-style-type: none"> → Engineer known chemical cycle materials to optimize heat transfer, kinetics and durability; and to minimize cost → Discover and develop new materials/materials classes, guided by theory and experimentation, with the potential for high efficiency, long cycle lifetime and low cost → Validate cycle efficiency and cycle life associated with all cycle reactant materials/phases
Innovative Thermochemical Reactor Designs	<ul style="list-style-type: none"> → Develop receiver materials and designs to minimize re-radiation losses and optimize lifetime → Develop receiver /reactor interface materials and designs for maximum thermal coupling, minimum loss and long lifetime → Develop thermal management and heat recuperation in receiver/reactor designs → Develop system to manage cycle reactants and products, including phase separations and purification → Develop system to manage variable demand and solar power, including thermal/chemical storage and required interfaces
Improved Electrolysis (Hybrid Cycles)	<ul style="list-style-type: none"> → Improved membrane materials with optimal conductivity, minimal chemical cross-over, and high durability → Improved end plate and catalyst materials → Optimize electrolyzer for low voltage, high efficiency and long lifetime
Practical Storage Strategies	<ul style="list-style-type: none"> → Develop thermal storage materials/strategies → Develop chemical storage materials/strategies
Reduced Solar Concentrator Costs	<ul style="list-style-type: none"> → Reduce heliostat system cost (leveraging CSP R&D) → Reduce dish concentrator systems (leveraging CSP R&D)
Reduced BOP and O&M Costs	<ul style="list-style-type: none"> → All system components must be considered in reducing BOP and O&M costs, including feed pre-conditioning, solar concentrators, solar receivers, reactor, hydrogen purification, controls, utilities, QA/QC (e.g., sensors), compression, storage, and safety
Technoeconomic Analysis	<ul style="list-style-type: none"> → Develop detailed technoeconomic models of prospective STCH reactors based on promising cycles implemented in promising reactor systems (including concentrator/receiver/reactor capital and O&M projected costs) to guide R&D efforts toward meeting H₂ cost threshold goals

Addressing all of the barriers to commercialization cost targets for STCH production will require simultaneous R&D efforts in several areas, along with efforts to develop policy, standards, and delivery infrastructure technology. Although these efforts are taking place concurrently, the impact of each effort on the entire hydrogen production system must be kept in mind and integrated into systems optimization efforts.

Identifying and developing the most promising cycle chemistries is the highest near-term research priority. Exploring cycle materials that provide operational durability and improved thermodynamics and kinetics is essential. Design and demonstration of efficient reactors and receivers suitable for the chemistries identified is another priority for achieving technical targets. To facilitate R&D of STCH reactant and reactor materials and systems, standardized testing and reporting protocols and metrics are being developed in conjunction with the broader solar fuels research community. Other important activities — e.g., minimizing losses through effective thermal management and reducing solar-

concentrator capital costs — are expected to leverage the R&D efforts of solar fuels initiatives and the DOE Solar Office.

O&M costs will also have a significant impact on the overall cost of STCH hydrogen production and will need to be minimized through process and engineering advances. Ultimately, additional efforts will be needed to develop and implement DFMA that will facilitate mass production of equipment and development of lower-cost, easier-to-manufacture, and more durable materials.

6.0 Photoelectrochemical

The photoelectrochemical (PEC) pathway calls for producing hydrogen via photoelectrochemical water splitting using semiconductor materials systems to collect and convert the sun's energy. It is an early-stage development technology that will be suitable for semi-central and central hydrogen production. The current R&D priority is materials and device development.

6.1 Current Status and Technical Targets

PEC hydrogen production is a solar-driven water-splitting process that converts solar energy directly to chemical energy in the form of hydrogen. Unlike other light-harvesting technologies, PEC relies on materials that couple photon absorption with water-splitting catalysis and hydrogen fuel formation. As such, PEC offers the potential for clean, sustainable hydrogen production. This roadmap identifies key milestones and research objectives to expedite technology development.

As PEC is in the relatively early stages of development, it will require increased understanding of the fundamental materials and interface processes and advances in materials systems and devices to achieve the long-term goals. As with all solar hydrogen technologies, large-scale PEC hydrogen production will require large areas for collecting sufficient sunlight, with the associated levels of land and capital costs. Since the PEC process operates at low temperatures (typically in the 20°-60°C range), the capital and O&M costs can be lower compared with alternative higher-temperature technologies (for example, the solar thermochemical processes that typically require >800°C). Maximizing conversion efficiency to reduce the overall footprint remains critical to cost reduction.

PEC Technology

PEC hydrogen production based on the direct use of solar energy to split water is attractive among STH conversion technologies because efficient STH conversion can potentially be achieved at low operating temperatures using cost-effective thin-film and/or particle-based materials. PEC R&D efforts to develop semiconductor materials, devices and systems are moving forward, benefiting from strong synergies with contemporary research efforts in photovoltaics (PV), nano-technologies, and computational materials.

The semiconductor materials systems used in the PEC process are similar to those used in PV solar electricity generation. For PEC applications, the semiconductor device is immersed in an aqueous environment and generates enough electrochemical potential to directly split water into hydrogen and oxygen gases upon exposure to sunlight. The development of PEC water-splitting systems has focused primarily on two reactor configurations: (a) a photoelectrode panel reactor and (b) a photocatalyst particle reactor, as illustrated in Figure 6.1.⁸⁸ Each approach offers its own benefits and challenges. The photoelectrode approach, however, has been studied most extensively to date, in part owing to the similarities with established PV-panel technologies.

Photoelectrochemical Production

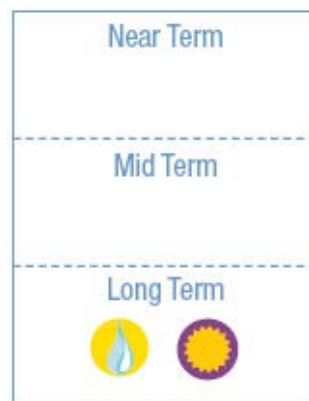

Feedstock:	Water
Energy Source:	Solar
Production:	Semi-Central Central

Environmental Benefits

By solely using water and the power of sunlight, photo-electrochemical technology offers the potential for clean, sustainable hydrogen production.

⁸⁸ B. Pinaud, J. Benck, L. Seitz, A. Forman, Z. Chen, T. Deutsch, B. James, S. Ardo, H. Wang, E. Miller, and T. Jaramillo, "Technical and economic feasibility of centralized facilities for solar hydrogen production via photocatalysis and photoelectrochemistry," *Energy and Environmental Science*, 2013 (submitted).

In fact, since the 1972 publication of Fujishima and Honda's seminal paper describing the PEC water-splitting process on a titanium dioxide photoelectrode,⁸⁹ significant technical advances in photoelectrode R&D have resulted in numerous functional bench-scale systems. To date, PEC photoelectrode panel reactors composed of crystalline III-V semiconductors have demonstrated STH efficiencies as high as 12.4%⁹⁰ and 18.3%,⁹¹ while multi-junction thin-film PEC cells have yielded efficiencies in the range of 4.7%⁹² to 7.8%⁹³ at the bench-top laboratory scale. Technology development hurdles include durability, efficiency, and cost.

In panel reactors, the PEC water-splitting process begins with the absorption of a solar photon by the semiconductor device to form an excited electron-hole pair. The electron and hole are separated by an internal electric field, established by the semiconductor–electrolyte interface or by solid-state junctions buried within the semiconductor. The separated electron and hole are then collected at different surfaces, where they drive the hydrogen- and oxygen-evolving reactions, respectively. PEC hydrogen production systems can incorporate a single photon-absorbing semiconductor, or multiple absorbers in a higher-efficiency tandem device.⁹⁴

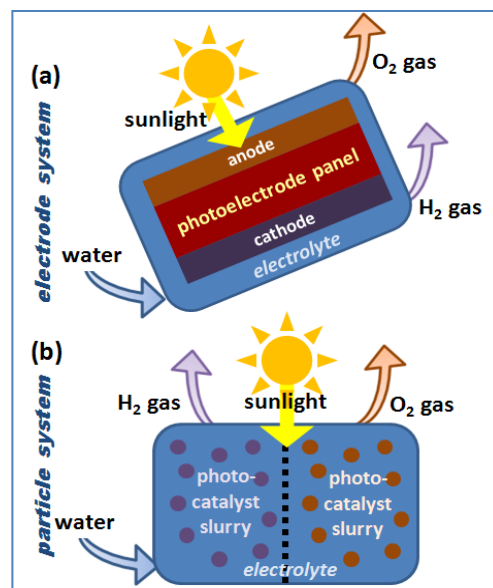

Figure 6.1. PEC Solar Water-splitting Reactors—(a) photo-electrode and (b) photocatalyst-particles

Figure 6.2 illustrates the basic operational principles of a generic tandem PEC structure incorporating two photoelectrodes (i.e., a photoanode and a photocathode). Under exposure to sunlight, oxygen evolution occurs on the surface of the n-type semiconductor photoanode, consuming photo-generated, positively charged “holes” (h^+) in the semiconductor band structure. Simultaneously, excited electrons (e^-) are driven toward the p-type semiconductor photocathode for hydrogen evolution. The net steady-state result of the simultaneous gas-evolving half-reactions is the solar-driven water-splitting process. A key feature of tandem configurations is voltage enhancement through stacking multiple light-sensitive components. Photo-generated voltages greater than 1.6 volts (V) are typically desired to overcome the thermodynamic energy barrier for water splitting (1.23 V per electron) plus additional losses (e.g., catalysis overpotential and cell resistance).

PEC hydrogen production may also be accomplished through the illumination of light-absorbing, semiconductor photocatalyst particles dispersed in water (Figure 6.3). Hydrogen and oxygen are evolved from separated H_2 and O_2 photocatalyst particles, as shown in the figure. The overall water-splitting

⁸⁹ A. Fujishima and K. Honda, “Photolysis-decomposition of water at the surface of an irradiated semiconductor,” *Nature* 238 (1972): 37–38.

⁹⁰ O. Khaselev and J. A. Turner, “A monolithic photovoltaic-photoelectrochemical device for hydrogen production via water splitting,” *Science* 280 (1998): 425–427.

⁹¹ S. Licht, B. Wang, S. Mukerji, T. Soga, M. Umeno, and H. Tributsch, “Efficient solar water splitting, exemplified by RuO_2 -catalyzed AlGaAs/Si photoelectrolysis,” *The Journal of Physical Chemistry B* 104 (2000): 8920–8924.

⁹² S. Y. Reece, J. A. Hamel, K. Sung, T. D. Jarvi, A. J. Esswein, J. J. H. Pijpers, and D. G. Nocera, “Wireless solar water splitting using silicon-based semiconductors and earth-abundant catalysts,” *Science* 334 (2011): 645–648.

⁹³ R. E. Rocheleau, E. L. Miller, and A. Misra, “High-efficiency photoelectrochemical hydrogen production using multijunction amorphous silicon photoelectrodes,” *Energy & Fuels* 12 (1998): 3–10.

⁹⁴ E.L. Miller, A. DeAngelis, and S. Mallory, “Multijunction Approaches to Photoelectrochemical Water Splitting,” in *Photoelectrochemical Hydrogen Production*, eds. R. van de Krol and M. Grätzel (New York: Springer, 2012) 205–276.

reaction is coupled by an intermediate ionic species “X” in solution (such as Fe^{3+}), which is reduced by the O_2 photocatalyst (e.g., to Fe^{2+}) and re-oxidized by the H_2 photocatalyst in a continuous closed-loop process.

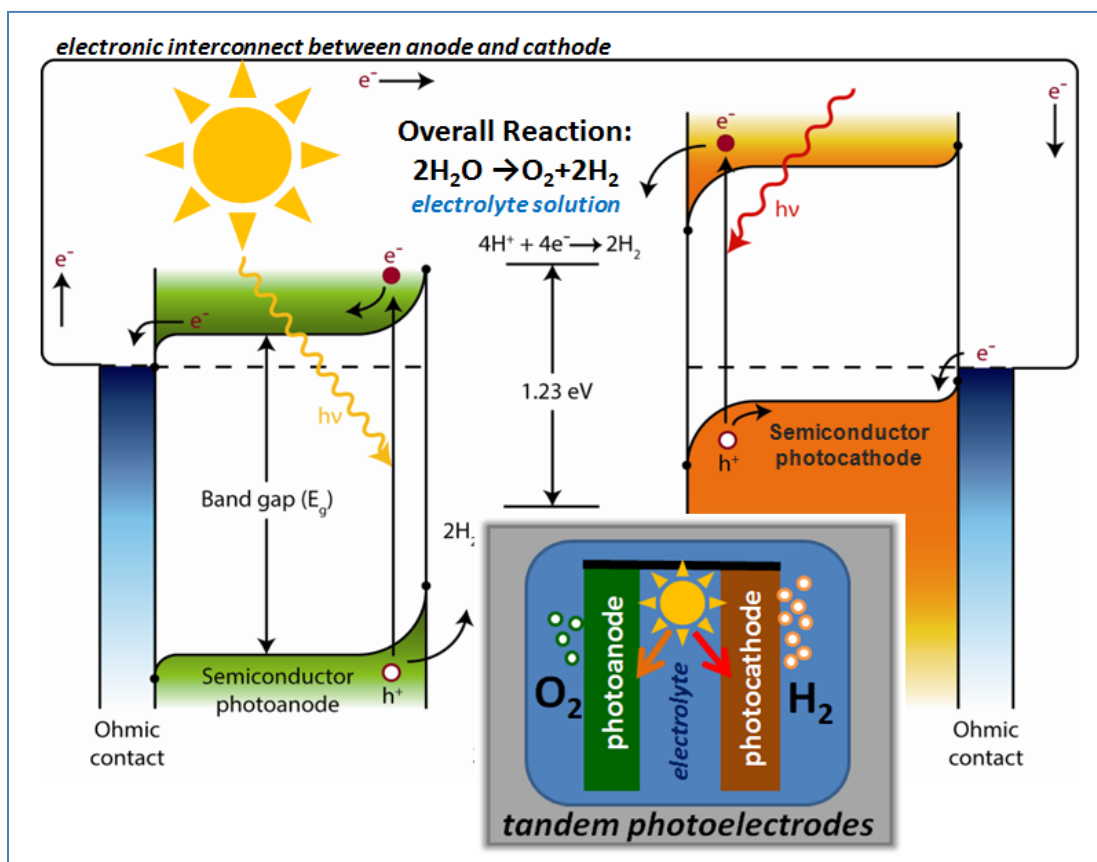

Figure 6.2. Photon absorption, band bending, charge separation, and hydrogen and oxygen evolution on semiconductor photoanode and photocathode surfaces are shown. The two electrodes can be directly coupled to eliminate wiring; alternatively, a redox mediator could be used to shuttle the charges (e.g., for particle semiconductors).

The merits of the various reactor configurations for PEC hydrogen must be evaluated in the context of broader technoeconomic analyses to determine the best paths forward for meeting the DOE cost threshold (\$2-\$4/kg) for dispensed (untaxed) hydrogen. Photoelectrode systems are more mature in their stage of development; devices have been fabricated with relatively high STH efficiencies ranging from 4% to 18%.⁹⁵ Photocatalyst systems, however, offer the potential for lower overall cost of hydrogen due to elimination of panel and panel-mount infrastructure. Early technoeconomic models of PEC reactor

⁹⁵ S. Licht, B. Wang, S. Mukerji, T. Soga, M. Umeno, and H. Tributsch, "Efficient solar water splitting, exemplified by RuO_2 -catalyzed AlGaAs/Si photoelectrolysis," *The Journal of Physical Chemistry B* 104 (2000): 8920–8924; S. Y. Reece, J. A. Hamel, K. Sung, T. D. Jarvi, A. J. Esswein, J. J. H. Pijpers, and D. G. Nocera, "Wireless solar water splitting using silicon-based semiconductors and earth-abundant catalysts," *Science* 334 (2011): 645–648; R. E. Rocheleau, E. L. Miller, and A. Misra, "High-efficiency photoelectrochemical hydrogen production using multijunction amorphous silicon photoelectrodes," *Energy & Fuels* 12 (1998): 3–10.

systems based on the H2A tool⁹⁶ have indicated the long-term potential for cost-effective hydrogen production through both approaches. Current R&D priorities are focused on materials discovery and

development, along with reactor design and engineering. As described below, these activities are directed to improve device performance (specifically, efficiency and durability) and decrease cost.

Independent of the PEC reactor type, there are several key requirements for semiconductor materials systems and devices for effective solar water-splitting.⁹⁷ These include:

- Suitable optical bandgap for optimal light absorption
- Good charge transport properties within the semiconductor bulk
- Proper thermodynamic band edge alignment for the gas-evolution redox reactions
- Fast kinetics for the hydrogen evolution reaction and the oxygen evolution reaction (typically the rate-limiting step) under the expected range of operating temperatures (20°-60°C) and pressures (300-400 psi)
- Long-term stability in the aqueous environment
- Low materials cost and availability.

In all cases, the PEC system bandgap must be large enough to provide the ~1.6 V needed to split water (e.g., over 1.8 eV), but as small as possible to absorb and convert a greater portion of the solar spectrum (e.g., less than 2.2 eV). Photo-generated voltage and solar flux utilization can be maximized by employing tandem configurations using multiple absorbers interconnected in series to yield a combined voltage sufficient for water splitting. This multi-absorber approach, similar to the photoelectrode and photocatalyst cases represented in Figures 6.2 and 6.3, respectively, has proven successful in the photovoltaic industry,⁹⁸ as well as in laboratory PEC water-splitting devices.⁹⁹ Through current R&D

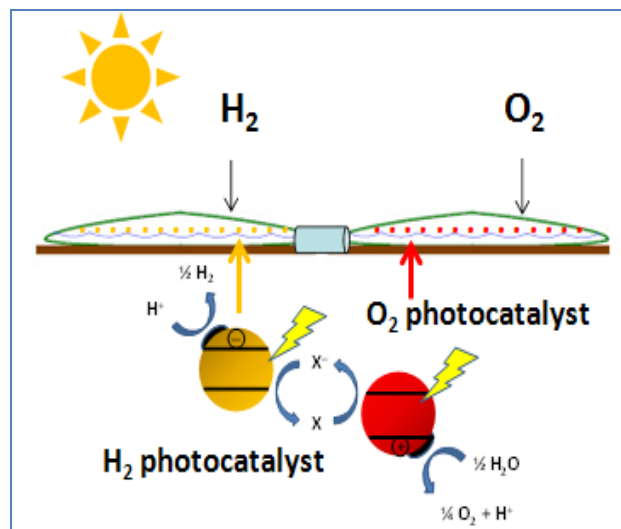

Figure 6.3. PEC Photocatalyst Reactor. Particles may be dispersed in low-cost plastic containers for separate H₂ and O₂ evolution. Hydrogen and oxygen are evolved from co-catalysts adsorbed on the surfaces of separate H₂ and O₂ photocatalyst particles. The overall reaction is facilitated by a redox mediator, X/X⁻ (e.g., Fe³⁺/Fe²⁺), which is shuttled between the hydrogen and oxygen reactor compartments.

⁹⁶ B. D. James, G. N. Baum, J. Perez, and K. N. Baum, *Technoeconomic Analysis of Photoelectrochemical (PEC) Hydrogen Production*, DOE Contract No. GS-10F-009J, produced by Directed Technologies Inc., Arlington, VA (Washington, DC: U.S. Department of Energy, 2009).

⁹⁷ M. G. Walter, E. L. Warren, J. R. McKone, S. W. Boettcher, Q. X. Mi, E. A. Santori, and N. S. Lewis, "Solar water splitting cells," *Chemical Reviews* 110 (2010): 6446–6473; A. J. Nozik and R. Memming, "Physical chemistry of semiconductor-liquid interfaces," *The Journal of Physical Chemistry* 100 (1996): 13061–13078; T. Bak, J. Nowotny, M. Rekas, and C. C. Sorrell, "Photo-electrochemical hydrogen generation from water using solar energy," *International Journal of Hydrogen Energy* 27 (2002): 991–1022; M. Kitano and M. Hara, "Heterogeneous photocatalytic cleavage of water," *Journal of Materials Chemistry* 20 (2010): 627–641; A. Kudo and Y. Miseki, "Heterogeneous photocatalyst materials for water splitting," *Chemical Society Reviews* 38 (2009): 253–278.

⁹⁸ S. van Riesen, A. Gombert, E. Gerster, T. Gerstmaier, J. Jaus, F. Eltermann, and A. W. Bett, "Concentrix Solar's progress in developing highly efficient modules," *AIP Conference Proceedings* 1407 (2011): 235–238; G. S. Kinsey, K. Stone, J. Brown, and V. Garboushian, "Energy prediction of Amonix CPV solar power plants," *Progress in Photovoltaics: Research and Applications* 19 (2011): 794–796; R. K. Jones, P. Hebert, P. Pien, R. R. King, D. Bhusari, R. Brandt, O. Al Taher, C. Fetzer,

efforts, efficient, durable and cost-effective PEC materials systems and devices are being developed with the assistance of state-of-the-art methods in materials theory, synthesis and characterization, and with development of standardized methods for testing and reporting on PEC materials experimental work.¹⁰⁰

Further advanced work will be needed on integration schemes for high-performance photoelectrode or photocatalyst reactors, recognizing that the constituent materials' market cost and accessibility are key considerations if solar hydrogen from water splitting is to be viable on a large scale.¹⁰¹ Guided by technoeconomic analyses, DOE R&D efforts focus on discovery, development and optimization of promising materials systems and devices with potential for achieving long-term cost thresholds for large-scale, centralized solar water-splitting reactor facilities. The spectrum of R&D needs at the materials, device and reactor levels represents the broad challenge for PEC hydrogen production.

DOE Cost Targets

PEC research supports the goal of long-term commercial hydrogen production using renewable sources at costs ultimately competitive with other renewable production methods. Recognizing the long-term potential for practical solar hydrogen production, DOE supports development of advanced PEC material systems and devices. The overarching research approach integrates available state-of-the-art theoretical, synthesis, and analytical techniques to identify and develop the most promising PEC material classes and integrated PEC devices to meet the challenges of efficiency, stability, and cost. The motivation for this approach has been clearly outlined in the DOE-EERE MYRD&D, detailing the fundamental technical barriers and philosophies for overcoming these barriers in both photoelectrode and photo-particle-based reactor systems. The specific short-term and longer-term hydrogen cost goals (rounded to the nearest dollar) for the different PEC production pathways, taken directly from the MYRD&D, are shown in Table 6.1.¹⁰²

Table 6.1. Photoelectrochemical Production Pathways — DOE Cost Targets¹⁰³

Year	Production Scale		Cost/gge (produced)
2015 Target	Central	• Photoelectrode system	\$17.30
		• Photo-particle system	\$28.60
2020 Target	Central	• Photo-electrode system	\$5.70
		• Photo-particle system	\$4.60

J. Ermer, A. Boca, D. Larrabee, X. Q. Liu, and N. Karam, "Status of 40% production efficiency concentrator cells at Spectrolab," *35th IEEE Photovoltaic Specialists Conference (PVSC)* (2010): 000189–000195.

⁹⁹ O. Khaselev and J. A. Turner, "A monolithic photovoltaic-photoelectrochemical device for hydrogen production via water splitting," *Science* 280 (1998): 425–427; S. Licht, B. Wang, S. Mukerji, T. Soga, M. Umeno, and H. Tributsch, "Efficient solar water splitting, exemplified by RuO₂-catalyzed AlGaAs/Si photoelectrolysis," *The Journal of Physical Chemistry B* 104 (2000): 8920–8924; R. E. Rocheleau, E. L. Miller, and A. Misra, "High-efficiency photoelectrochemical hydrogen production using multijunction amorphous silicon photoelectrodes," *Energy & Fuels* 12 (1998): 3–10.

¹⁰⁰ Z. Chen, T. F. Jaramillo, T. G. Deutsch, A. Kleiman-Shwarsstein, A. J. Forman, N. Gaillard, R. Garland, K. Takanebe, C. Heske, M. Sunkara, E. W. McFarland, K. Domen, E. L. Miller, J. A. Turner, and H. N. Dinh, "Accelerating materials development for photoelectrochemical hydrogen production: Standards for methods, definitions, and reporting protocols," *Journal of Materials Research* 25 (2010): 3–16.

¹⁰¹ P. C. K. Vesborg and T. F. Jaramillo, "Addressing the terawatt challenge: scalability in the supply of chemical elements for renewable energy," *RSC Advances* 2 (2012): 7933–7947.

¹⁰² Office of Energy Efficiency and Renewable Energy, *Fuel Cell Technologies Office Multi-Year Research, Development, and Demonstration Plan* (Washington, DC: U.S. Department of Energy, November 2012), Section 3.1, www1.eere.energy.gov/hydrogenandfuelcells/mypp/.

¹⁰³ Ibid.

6.2 Gaps and Technical Barriers

Driving DOE's research activities are specific barriers identified in the MYRD&D, as well as others identified by the U.S. DRIVE Partnership's HPTT. A summary of these barriers is provided in Table 6.2 followed by further detailed descriptions.

Table 6.2. Photoelectrochemical Hydrogen Production — Summary of Barriers

Materials and Device Barriers	Efficiency Challenges: PEC semiconductor materials systems that provide adequate STH conversion efficiency while meeting durability requirements need to be identified and more fully developed.
	Durability Challenges: Corrosion of PEC materials systems from oxidation and reduction in aqueous environments, both under illumination and in the dark, presents a barrier to the durability of efficient semiconductor materials systems.
	Materials Cost Challenges: Cost of the PEC semiconductor materials system has a direct impact on capital costs and hydrogen production cost. Higher efficiency results in a smaller reactor footprint with a reduced amount of required material and lower cost; however, to date, efficient materials systems remain too costly, even with the projected smaller reactor footprints (though modest solar concentration up to 10 [×] can provide one pathway to further reduction in semiconductor material requirements).
	Integrated Device Challenges: Multi-layer, functionalized photo-electrode or photocatalyst device approaches address a number of the materials barriers, including high efficiency and corrosion protection, but design and fabrication challenges remain in the optimization of integrated device configurations for both photo-particle systems and for photo-electrode systems capable of operating at modest concentration levels (up to 10 [×]).
	Auxiliary Materials Development: In addition to the PEC semiconductor light-absorber materials, effective surface treatments and auxiliary linking materials (e.g., particle photocatalyst redox mediators and electronic interconnecting layers in photoelectrode devices) are needed in integrated devices for achieving ultimate targets in PEC solar hydrogen production. Accelerated development is needed in this area.
System Level Barriers	Capital and Operations Costs: System-level cost of PEC hydrogen production remains a key barrier. Integrated system and BOP costs must be reduced to meet cost targets; relevant system costs include PEC materials systems and devices with reactor materials; BOP costs include controls, sensors, driers and compressors. Also included are costs of commodity materials of construction and auxiliary system components, along with the impact of these costs as a function of various parameters (e.g. device efficiency, scale).
Land Costs	Land Area Requirements: Commercial-scale PEC solar hydrogen production will require large areas for collecting sufficient sunlight, with the associated land costs.

Conversion Efficiency

PEC semiconductor efficiency is limited by light absorption, charge separation and charge transport in the bulk, and by energetics and charge transfer at the solid–liquid interface. Further development is needed for materials systems, such as tandem configurations, with appropriate bandgap for light absorption (e.g., <2.2 eV), with band-edges aligned energetically for hydrogen and oxygen evolution, with low-loss charge separation and transport in the solid state, and with interfaces kinetically favorable for the photoelectrochemical water-splitting half reactions. Technoeconomic analysis has indicated that meeting

DOE cost targets will require durable PEC semiconductor material systems that provide a STH efficiency of >25% (photo-electrode configuration) or >10% (photo-particle configurations)¹⁰⁴ (as a point of reference, PEC efficiencies in excess of 40% STH are possible under ideal circumstances.) Standardized theoretical, synthesis, and characterization methods in materials discovery and screening are important tools in the basic understanding of the bulk and interface loss mechanisms that limit efficiency. Such understanding is expected to greatly expedite development of PEC materials systems with efficiencies needed to meet DOE hydrogen cost targets.

Materials/Interface Durability

PEC semiconductor/electrolyte junctions are prone to both dark- and light-induced degradation due to corrosion reactions that compete with water-splitting half-reactions at the interfaces. Intrinsically durable materials with the appropriate characteristics for high-efficiency PEC hydrogen production goals have not been identified. For example, the high-efficiency materials currently available are prone to corrosion, while the most durable materials studied to date have demonstrated substantially lower STH conversion efficiency. Discovery of intrinsically stable and efficient materials would be an ideal solution to this barrier, but such a finding represents a significant challenge. Promising alternative approaches focus on modification of surfaces through coatings or dispersions that stabilize the interface (energetically or kinetically) and protect the bulk. The use of PEC theory, synthesis, and characterization methods can facilitate a better understanding of corrosion mechanisms for development of mitigation schemes to enhance durability.

Materials Cost

Cost of the PEC semiconductor material system has a direct impact on capital costs and, thus, hydrogen production cost. High-efficiency crystalline III-V materials systems are being developed to meet efficiency and durability requirements, but the cost of these materials could be prohibitive to large-scale deployment. Solar concentrator schemes to reduce the semiconductor footprint and new synthesis technologies are possible approaches for overcoming the cost barriers to utilizing crystalline semiconductors in PEC reactors. Lower-efficiency materials systems based on lower-cost thin-film or particle semiconductors are also being developed. Improved efficiencies are needed in these material systems.

Auxiliary Materials

In addition to the semiconductor absorber materials, auxiliary materials for integrated PEC devices include surface treatments and interface/linking materials (including soluble, transparent redox mediators for the particle-based systems). Techniques are needed to synthesize these integrated device configurations while maintaining each component material's integrity, and appropriate manufacturing techniques based on these synthesis routes will be needed to scale device configurations to commercial scales.

Integrated Devices

Achieving ultimate targets in PEC solar hydrogen production requires efficient and stable integrated devices combining the best available PEC semiconductors, surface treatments and auxiliary interface materials. These can be planar-integrated devices for photo-electrode reactor configurations or functionalized particle devices for photocatalyst reactor configurations. Integrated device designs that combine functionalized materials specifically optimized for light absorption, charge transport and interfacial catalysis could simultaneously address issues of durability and efficiency. Even with the best

¹⁰⁴ Office of Energy Efficiency and Renewable Energy, *Fuel Cell Technologies Office Multi-Year Research, Development, and Demonstration Plan* (Washington, DC: U.S. Department of Energy, November 2012), Section 3.1, www1.eere.energy.gov/hydrogenandfuelcells/mypp/.

available semiconductor absorber materials with properties consistent with efficient PEC solar water splitting, integration into optimized high-efficiency devices requires specific applied and engineering R&D efforts.

System-Level Considerations

Determination of the most cost-effective reactor configurations will require rigorous technoeconomic analysis, taking into account materials performance and cost parameters in addition to O&M costs. Technoeconomic models to compare the cost-effectiveness of different PEC reactor approaches need to take into account the system-level costs and the performance and cost parameters of the PEC materials systems under development. Reactors and systems must be designed to account for such elements as diurnal operation, water purity, ion transport (e.g., cell resistance), and gas handling (including drying and compression); and these systems must be evaluated based on costs of commodity materials of construction and system components. In addition, the overall cost sensitivity of hydrogen must be estimated as a function of these various engineering parameters. Additional BOP components for different PEC reactor configurations could include transparent coverings for light transmission and gas trapping, ionic conduits, gas separations technologies, and light-concentrating hardware (among others).

6.3 Strategy to Overcome Barriers and Achieve Technical Targets

Table 6.3 lists the critical technology development needs for PEC hydrogen production. R&D activities within these categories address the critical technology barriers to the ultimate commercialization of PEC solar hydrogen generation.

Table 6.3. Photoelectrochemical — Critical Technology Needs

Materials and Device Development	<ul style="list-style-type: none"> ➔ Light-absorbing semiconductor materials systems compatible with high STH efficiency devices (>25% for photo-electrode configurations and >10% for photo-particle systems, typically requiring material system bandgap less than 2.0 eV for absorbing a high percentage of the solar irradiance) ➔ Redox mediators for photo-particle PEC that are stable and transparent to visible light ➔ Catalytic/protective surface coatings compatible with operating conditions of high-efficiency STH devices ➔ Methods of fabrication that yield photo-electrode/ photocatalyst materials at target costs and target STH efficiencies
Development of Supporting Scientific and Engineering Methodologies	<ul style="list-style-type: none"> ➔ Advanced theoretical models of PEC semiconductor bulk and interface properties ➔ Advanced theoretical models of particle PEC that provide estimates of system efficiency as a function of particle size, bandgap, and rate of back reactions (i.e., with the redox mediator) ➔ Comprehensive portfolio of standard and advanced characterization tools for evaluating PEC materials and interfaces ➔ Wide portfolio of state-of-the-art techniques for synthesis of PEC materials and devices ➔ Theory-guided screening tools for discovery and development of novel PEC materials systems ➔ Experimental combinatorial synthesis/rapid screening tools for discovery and development of novel PEC materials systems ➔ Standardized protocols for evaluation and reporting of PEC materials and device physical and operational parameters
Development of System-Level Technoeconomic Analysis	<ul style="list-style-type: none"> ➔ Detailed technoeconomic models of photo-electrode-based PEC reactor systems, including sensitivity analysis of prime contributing factors to hydrogen production cost ➔ Detailed technoeconomic models of photo-particle-based PEC reactor systems, including sensitivity analysis of prime contributing factors to hydrogen production cost ➔ Prioritization of fundamental and applied R&D needs for addressing the critical factors for reducing hydrogen production costs to meet DOE cost threshold targets

Addressing all of the barriers to commercialization cost targets for PEC production will require simultaneous R&D efforts in several areas, along with efforts to develop policy, standards, and delivery infrastructure technology. Although these efforts are taking place concurrently, the impact of each effort on the entire hydrogen production system must be kept in mind and integrated into systems optimization efforts.

Current R&D priorities in PEC solar hydrogen production include fundamental, applied and engineering efforts to discover, develop and optimize materials systems and device configurations capable of achieving DOE targets. To achieve the overall DOE hydrogen production cost target, a number of trade-offs can be made among the efficiency, durability, and cost parameters of the materials and devices. System-level technoeconomic analysis remains an important activity for developing long-term technical and cost targets for both photo-electrode and photocatalyst reactor systems. Efforts to develop detailed reactor designs, however, are not expected to become a priority until appropriate materials systems and devices have been established.

Current PEC materials research is progressing simultaneously on three fronts. The first is the study of highly efficient light absorbers, typically with limited lifetimes and relatively high cost (e.g., Group III-V crystalline semiconductor materials), to establish performance benchmarks and to quantify PEC hydrogen generation versus corrosion mechanisms. The second is the study of stable thin-film materials systems, typically with lower visible light absorption efficiency and relatively lower cost (e.g., metal- and mixed-metal oxide thin films, silicon alloy thin films, and chalcopyrites and other emerging efficient thin-film absorbers) to mitigate optical and electronic losses for improving efficiency toward benchmark values. The third is development of sophisticated multi-component devices and systems with the potential to achieve efficient PEC water splitting through the effective combination of functionalized materials specifically optimized for light absorption, charge transport and interfacial catalysis. Current R&D efforts are using state-of-the-art methods in materials theory, synthesis and characterization to develop efficient, durable and cost-effective materials systems. These research efforts are supported by the development of standardized methods for testing and reporting on PEC materials experimental work.¹⁰⁵ Further advanced work will be needed on integration schemes into high-performance photo-electrode or photocatalyst devices and reactors. Commercially viable large-scale deployment will require identifying and developing cost-effective methods of engineering and manufacturing the best available PEC materials, devices and systems.

¹⁰⁵ Z. Chen, T. F. Jaramillo, T. G. Deutsch, A. Kleiman-Shwarscstein, A. J. Forman, N. Gaillard, R. Garland, K. Takanebe, C. Heske, M. Sunkara, E. W. McFarland, K. Domen, E. L. Miller, J. A. Turner, and H. N. Dinh, "Accelerating materials development for photoelectrochemical hydrogen production: Standards for methods, definitions, and reporting protocols," *Journal of Materials Research* 25 (2010): 3–16.

7.0 Photobiological

The photobiological pathway calls for producing hydrogen using photosynthetic microorganisms. This is a long-term technology that will most likely be suitable for semi-central and central hydrogen production facilities.

7.1 Current Status and Technical Targets

Photobiological hydrogen production uses microorganisms to convert solar energy into hydrogen. Photolytic production uses microorganisms, such as green microalgae or cyanobacteria, and sunlight to split water through direct or indirect photolysis routes. In photofermentative hydrogen production, sunlight is the driver for photosynthetic bacteria to break down organic compounds (either generated by the microbes themselves or supplied to them), releasing hydrogen. By using sunlight and water (added organic compounds are also an option), photobiological hydrogen production offers a potential for clean, sustainable hydrogen production. This roadmap focuses primarily on initial development needs, but it also reports obstacles that will need to be avoided or minimized to reduce time to deployment.

Photobiological hydrogen production is in the early stages of development and, to achieve the long-term goals, will require increased understanding of microbial energy pathways to improve STH conversion efficiency, and molecular engineering to overcome oxygen tolerance issues.¹⁰⁶ Photolytic biological production can in some ways be considered similar to PEC systems (Chapter 6), using microbes rather than synthetic catalysts to split water using solar energy.

Photobioreactors are still in the early stages of development for all photobiological fuel production, both for hydrogen and other liquid hydrocarbon fuel systems; they can nonetheless be considered similar to PEC reactors, particularly the particle systems. In both cases, optically transparent, hydrogen-compatible materials will be needed to maximize light utilization, and the system footprint will be guided by both the total solar energy per unit area and by how effective the system is at converting that total energy to hydrogen (STH efficiency).

Photobiological systems may have some advantages compared to other water-splitting production systems. Feedstock water does not have to be pure and potentially could be waste water, keeping feedstock costs low while supplying needed nutrients, depending on the content of the waste water. In addition, as the reactive materials are living organisms, they are both self-replicating and self-healing, potentially reducing the “material” manufacturing and maintenance costs. On the other hand, photobiological systems face challenges that other production systems do not. For example, photolytic microorganisms produce hydrogen and oxygen as a mixture rather than at separate locations, and

Photobiological Hydrogen Production

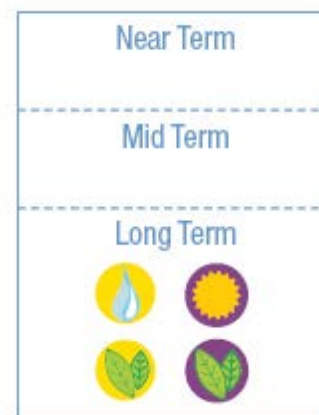

Feedstock:	Water Biomass
Energy Source:	Solar Biomass
Production:	Semi-Central Central

Environmental Benefits

Research in photobiological hydrogen has progressed in recent years, though it is still in the early stages. In the long term, photobiological production technologies may provide economical hydrogen production from sunlight with low- to net-zero carbon emissions.

¹⁰⁶ M. L. Ghirardi et al., “Photobiological hydrogen-producing systems,” *Chem Soc Rev.* 38, no. 1 (January 2009): 52–61, doi: 10.1039/b718939g; Review, Erratum in *Chem Soc Rev.* 38, no. 12 (December 2009): 3505; W. S. Kontur, D. R. Noguera, and T. J. Donohue, “Maximizing reductant flow into microbial H₂ production,” *Curr Opin Biotechnol.* 23, no. 3 (June 2012): 382–9, doi: 10.1016/j.copbio.2011.10.003.

photosynthetic systems are saturated at relatively low light levels and therefore are unable to use all the solar energy collected at full sunlight conditions.

Photobiological Technology

Every year, the number of microorganisms identified for potential use in these technologies increases. Compared to the large number of naturally occurring microorganisms, only a fraction have been functionally characterized, so research is ongoing to discover those with the necessary characteristics for hydrogen production. For example, just over 60% of the estimated 8,000 species of cyanobacteria and 13,000 species of *Chlorophyta* (a group of green algae) have even been described.¹⁰⁷ Because the fraction of microorganisms that can be cultured in current lab conditions is small (~1%), continued research is needed to take advantage of methods that allow the study of organisms without the need to cultivate them, such as the analysis of the growing number of libraries of genes isolated from environmental samples to identify novel hydrogen-production genes.¹⁰⁸ Known organisms are also being modified to improve their characteristics.¹⁰⁹ Several recent review articles provide in-depth descriptions of the reaction pathways and types of enzymes being used in studies of photobiological hydrogen production.¹¹⁰

Photolytic hydrogen production uses light to split water into hydrogen and oxygen. This can be accomplished in two ways, depending on the microorganism (see Figure 7.1[A]). Green algal and cyanobacterial photosynthesis capabilities can be used to generate oxygen and hydrogen ions. A hydrogenase enzyme then converts the hydrogen ions to hydrogen gas. The second pathway, present only in cyanobacteria, is similar; it uses direct photolysis to split the water but employs a nitrogenase (nitrogen fixing) enzyme to produce hydrogen. Nitrogenase production of hydrogen only occurs in the absence of nitrogen and requires additional inputs of ATP (adenosine-5'-triphosphate, a common energy carrier in cells), which can reduce the overall efficiency compared to hydrogenase production. In both cases, the oxygen evolved from water splitting can inhibit the hydrogenase and nitrogenase enzymes.

Currently, the STH conversion efficiencies are low, <1% at full sunlight levels, and under full production conditions, hydrogen production lasts no more than approximately two minutes before the co-produced oxygen shuts down the enzymes. Current analysis indicates that to reach the DOE threshold cost target of \$2–\$4/gge, a STH efficiency of 17% is needed in an organism that can continue production through the modeled eight hours of sunlight per day. At 17% STH efficiency, a system could produce 30.6 g H₂/m²/day, or 123.8 kg/acre/day.¹¹¹ Indirect biological photolysis occurs when the sugars and starches (produced through the photosynthesis-driven Calvin cycle) are broken down during fermentation; if this occurs in the dark or under other conditions where the photosystem is not actively evolving oxygen,

¹⁰⁷ M. D. Guiry, “How many species of algae are there?” *Journal of Phycology* 48 (2012): 1057-1063.

¹⁰⁸ G. Maroti et al., “Discovery of [NiFe] Hydrogenase Genes in Metagenomic DNA: Cloning and Heterologous Expression in *Thiocapsa roseopersicina*,” *Applied and Environmental Microbiology* (September 2009): 5821–5830.

¹⁰⁹ H. Kirst et al., “Truncated Photosystem Chlorophyll Antenna Size in the Green Microalga *Chlamydomonas reinhardtii* upon Deletion of the TLA3-CpSRP43 Gene,” *Plant Physiol.* 160, no. 4 (December 2012): 2251–60, doi: 10.1104/pp.112.206672; P. Weyman, “Hydrogen from Water in a Novel Recombinant Oxygen-Tolerant Cyanobacterial System” (Annual Merit Review Presentation, 2012).

¹¹⁰ M. L. Ghirardi et al., “Photobiological hydrogen-producing systems,” *Chem Soc Rev.* 38, no. 1 (January 2009): 52–61, doi: 10.1039/b718939g; Review, Erratum in *Chem Soc Rev.* 38, no. 12 (December 2009): 3505; W. S. Kontur, D. R. Noguera, and T. J. Donohue, “Maximizing reductant flow into microbial H₂ production,” *Curr Opin Biotechnol.* 23, no. 3 (June 2012): 382–9, doi: 10.1016/j.copbio.2011.10.003; M. D. Redwood, M. Paterson-Beedle, and L. E. Macaskie, “Integrating dark and light biohydrogen production strategies: towards the hydrogen economy,” *Reviews in Environmental Science and Bio/Technology* 8, no. 2 (2009): 149–185; P. C. Hallenbeck, M. Abo-Hashesh, and D. Ghosh, “Strategies for improving biological hydrogen production,” *Bioresour Technol.* 110 (April 2012): 1–9, doi: 10.1016/j.biortech.2012.01.103.

¹¹¹ Office of Energy Efficiency and Renewable Energy, *Fuel Cell Technologies Office Multi-Year Research, Development, and Demonstration Plan* (Washington, DC: U.S. Department of Energy, November 2012), Section 3.1, www1.eere.energy.gov/hydrogenandfuelcells/mypp/.

hydrogenase and nitrogenase are not inhibited by oxygen. The added steps reduce the maximum potential conversion efficiency, but may alleviate oxygen tolerance issues.

Photofermentative bacterial hydrogen production uses anoxygenic photosynthetic bacteria to evolve hydrogen (Figure 7.1[B]). These bacteria lack Photosystem II, which is responsible for splitting water into hydrogen and oxygen in photolytic organisms. Instead, photosynthesis provides the energy to more fully break down organic substrates and also drive the nitrogenase reaction that combines the electrons and protons derived from organic substrate metabolism. The process occurs in deficient nitrogen conditions and, in the case of certain bacteria such as purple non-sulfur bacteria (PNS), can use primarily near-infrared light energy. Organic acids are a preferred substrate, although other reduced compounds can be employed.¹¹² At full light intensities, the efficiencies are less than 1%,¹¹³ below the DOE 2020 target of 4.5%.¹¹⁴

A. Photolytic biological hydrogen production

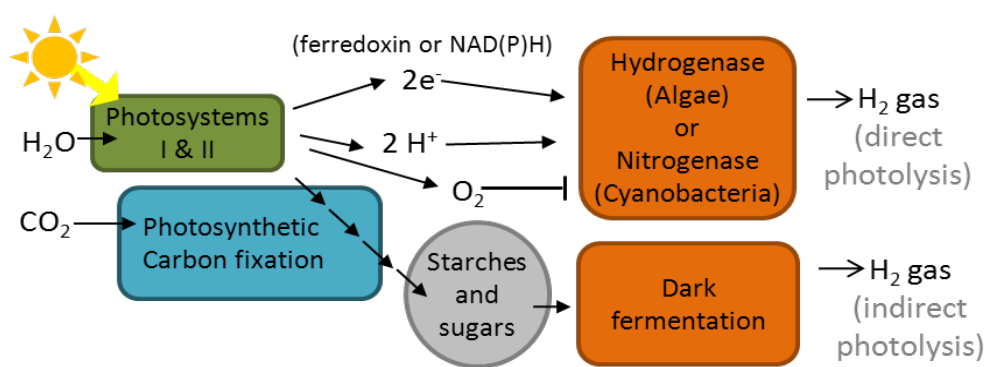

B. Photofermentative biological hydrogen production

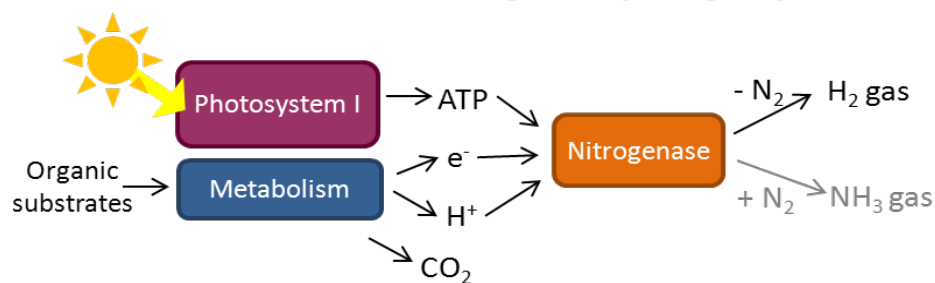

Figure 7.1. Photobiological Pathways

¹¹² M. L. Ghirardi et al., "Photobiological hydrogen-producing systems," *Chem Soc Rev.* 38, no. 1 (January 2009): 52–61, doi: 10.1039/b718939g; Review, Erratum in *Chem Soc Rev.* 38, no. 12 (December 2009): 3505; W. S. Kontur, D. R. Noguera, and T. J. Donohue, "Maximizing reductant flow into microbial H₂ production," *Curr Opin Biotechnol.* 23, no. 3 (June 2012): 382–9, doi: 10.1016/j.copbio.2011.10.003; P. C. Hallenbeck, M. Abo-Hashesh, and D. Ghosh, "Strategies for improving biological hydrogen production," *Bioresour Technol.* 110 (April 2012): 1–9, doi: 10.1016/j.biortech.2012.01.103.

¹¹³ Ibid.

¹¹⁴ Office of Energy Efficiency and Renewable Energy, *Fuel Cell Technologies Office Multi-Year Research, Development, and Demonstration Plan* (Washington, DC: U.S. Department of Energy, November 2012), Section 3.1, www1.eere.energy.gov/hydrogenandfuelcells/mypp/.

Combined Systems

The nearest-term opportunity is likely a system in which photobiological systems are combined with other energy-production technologies whose waste by-products can be used to enhance photobiological hydrogen production, for example, organic acid by-products of dark fermentation or carbon dioxide from fossil fuel electricity generation.¹¹⁵ In such systems, barriers for individual technologies would not have to be completely overcome, as long as the combined system could produce hydrogen at a reasonable cost, including possible cost off-sets provided by utilization of waste products.

Another combined system might take advantage of the different wavelengths collected by different organisms. Green algae and cyanobacteria can collect light in the range of 400-700 nanometers (nm) and some cyanobacterial chlorophyll variants are able to collect light wavelengths up to 740–750 nm, while some photosynthetic bacteria can collect light from 400 to 600 nm and from 800 to 1000 nm.¹¹⁶ Combining the light collection apparatuses could result in an organism or system that can collect light from 400 to 750 nm and from 800 to 1000 nm, increasing the portion of useable sunlight available to the cells.¹¹⁷

An integrated biological system, in which hydrogen is produced at each step, may increase the feasible hydrogen production capability versus stand-alone, single-technology systems.¹¹⁸ An alternative to co-culturing the photobiological strains would be to transfer the photosystem of one type into the other, for example, inserting the genes for the photosynthetic bacterial light collection system into a cyanobacterium or algal strain.¹¹⁹ This could be further integrated with fermentative technologies, discussed in the next chapter, by providing the microbes in the photobioreactor with fermentation effluent as an organic molecule feedstock and/or harvesting excess cells from the photobioreactor for use in the fermentation system for the biomass feedstock.¹²⁰

DOE Cost Targets

Long-term research will be required to meet the DOE's cost targets for photobiological hydrogen production. DOE's current R&D priority for photobiological hydrogen production is the initial analysis of the technology application. The current research objective is to verify the feasibility of using biological

¹¹⁵ M. L. Ghirardi et al., "Photobiological hydrogen-producing systems," *Chem Soc Rev.* 38, no. 1 (January 2009): 52–61, doi: 10.1039/b718939g; Review, Erratum in *Chem Soc Rev.* 38, no. 12 (December 2009): 3505; M. D. Redwood, M. Paterson-Beedle, and L. E. Macaskie, "Integrating dark and light biohydrogen production strategies: towards the hydrogen economy," *Reviews in Environmental Science and Bio/Technology* 8, no. 2 (2009): 149–185; P. C. Hallenbeck, M. Abo-Hashesh, and D. Ghosh, "Strategies for improving biological hydrogen production," *Bioresour Technol.* 110 (April 2012): 1–9, doi: 10.1016/j.biortech.2012.01.103.

¹¹⁶ M. L. Ghirardi et al., "Photobiological hydrogen-producing systems," *Chem Soc Rev.* 38, no. 1 (January 2009): 52–61, doi: 10.1039/b718939g; Review, Erratum in *Chem Soc Rev.* 38, no. 12 (December 2009): 3505.

¹¹⁷ R. E. Blankenship et al., "Comparing photosynthetic and photovoltaic efficiencies and recognizing the potential for improvement," *Science* 332, no. 6031 (May 13, 2011): 805–9, doi: 10.1126/science.1200165.

¹¹⁸ B. D. James et al., *Technoeconomic Boundary Analysis of Biological Pathways to Hydrogen Production*, NREL/SR-560-46674, produced by Directed Technologies Inc., Arlington, VA (Golden, CO: National Renewable Energy Laboratory, September 2009), <http://www1.eere.energy.gov/hydrogenandfuelcells/pdfs/46674.pdf>.

¹¹⁹ R. E. Blankenship et al., "Comparing photosynthetic and photovoltaic efficiencies and recognizing the potential for improvement," *Science* 332, no. 6031 (13 May 2011): 805–9, doi: 10.1126/science.1200165.

¹²⁰ M. L. Ghirardi et al., "Photobiological hydrogen-producing systems," *Chem Soc Rev.* 38, no. 1 (January 2009): 52–61, doi: 10.1039/b718939g; Review, Erratum in *Chem Soc Rev.* 38, no. 12 (December 2009): 3505; P. C. Hallenbeck, M. Abo-Hashesh, and D. Ghosh, "Strategies for improving biological hydrogen production," *Bioresour Technol.* 110 (April 2012): 1–9, doi: 10.1016/j.biortech.2012.01.103; M. D. Redwood, M. Paterson-Beedle, and L. E. Macaskie, "Integrating dark and light biohydrogen production strategies: towards the hydrogen economy," *Reviews in Environmental Science and Bio/Technology* 8, no. 2 (2009): 149–185.

systems to produce cost-competitive hydrogen in the long term by 2020.¹²¹ Because of the early stage of this technology, 2015 cost targets have not yet been established; 2020 targets are given below and in Table 7.1. The ultimate DOE threshold goal is ≤\$2.00/gge.

- By 2020, identify advanced biological generation technologies to produce hydrogen with a projected cost of \$10.00/gge at the plant gate.
- By 2020, demonstrate photobiological water-splitting systems with potential to produce hydrogen at large scale with STH energy conversion efficiencies ≥5%.

Table 7.1. Photobiological Hydrogen Production — DOE Cost Targets¹²²

Year	Production Scale	Cost/gge (produced)
2020 Target	Central	\$9.20

7.2 Gaps and Technical Barriers

Driving DOE’s research activities are specific barriers identified in the MYRD&D, as well as others identified by the U.S. DRIVE Partnership’s HPTT. A summary of these barriers is provided in Table 7.2, which are described more fully on the following pages.

Table 7.2. Photobiological Hydrogen Production — Summary of Barriers

Photobiological Microorganism Limitations	<p>Lack of Identified Species and Metabolic Pathways: The organisms and pathways that have been characterized so far do not have the characteristics needed to meet DOE targets. Though microorganisms may exist in nature with better characteristics, only a small percentage of the multitude of naturally occurring microorganisms, or their genes and activities, have been identified and characterized, particularly for hydrogen production activity.</p>
	<p>Light Utilization: Photosynthetic organisms generally collect more photons than can be utilized by the photosystems at a given time. These excess photons, which could otherwise be used by cells lower in the culture, are dissipated as waste heat, reducing the light-to-hydrogen conversion efficiency of the culture.</p>
	<p>Rate of Hydrogen Production: Hydrogen production conversion efficiencies and rates are far too low for economical hydrogen production. Two major reasons are thought to be (1) the non-dissipation of a proton gradient across the photosynthetic membrane, and (2) the existence of competing metabolic flux pathways for reductant (i.e., the microorganisms making other products in addition to hydrogen). Hydrogen uptake in some species also reduces net hydrogen production.</p>
	<p>Diurnal and Seasonal Operation Limitation: Photobiological processes are discontinuous because they depend on sunlight, which is unavailable at night and available at only low intensities on cloudy days.</p>

¹²¹ Office of Energy Efficiency and Renewable Energy, *Fuel Cell Technologies Office Multi-Year Research, Development, and Demonstration Plan* (Washington, DC: U.S. Department of Energy, November 2012), Section 3.1, www1.eere.energy.gov/hydrogenandfuelcells/mypp/.

¹²² Ibid.

Table 7.2. (Cont.)

Photolytic Barriers	Continuity of Photoproduction: Oxygen co-produced with hydrogen in photolytic processes inhibits the microbes' hydrogen production activity and reduces hydrogen production duration to less than five minutes.
	Photosynthesis/Respiration Capacity Ratio: Optimum photosynthesis/respiration (P/R) ratio of <1 needs to be maintained. This is currently accomplished by nutrient deprivation, which decreases the production efficiency.
	Co-production of Oxygen: Photolytic water splitting results in the co-production of oxygen and hydrogen, which raises safety issues and necessitates the use of separation methods prior to collecting the gases. Oxygen sensitivity of the hydrogenase is an additional barrier.
Photofermentation Barriers	Carbon/Nitrogen Ratio: The carbon/nitrogen (C/N) ratio dramatically affects nitrogenase activity and must be properly maintained, or the enzyme must be re-engineered to reduce nitrogen inhibition.
	Photofermentation Production: Current rates of photofermentative hydrogen production are low, and co-produced by-products may reduce production and growth.
	Feedstock Issues: If used, organic matter feedstocks must be cost-effective and available in sufficient quantity and quality.
Combined System Barriers	Co-Culture Balance: For combined cultures, the proper mixtures of microbes and techniques to maintain the optimal balance have not been developed. For systems that are connected but cultured separately, appropriate volume and methods to connect the systems must be determined.
	Biomass Utilization: Strains must be developed to use the by-products and cell biomass from system components as feed for other system processes. These feed concentrations may need to be tightly controlled to maximize the performance and life of the system.
Systems Engineering	System Design: In addition to the common systems engineering challenges, methods to optimize microbial growth and maintenance will need to be considered in system design. Closed photobioreactors will be needed for the collection of hydrogen. Methods to efficiently collect, separate, and purify the hydrogen will be needed.

Common Photobiological Microorganism Barriers

A number of common barriers exist for both photolytic and photofermentative microorganisms. For economic viability, strains need to have higher levels of hydrogen production than are currently available, and be low-cost to obtain, grow, and maintain. At present, strains with either natural or engineered improvements in one of the areas described below are generally not improved in other areas. Ultimately, these improvements will need to be integrated to maximize hydrogen production rates.

The natural diversity of microorganisms throughout the world makes it likely that strains do exist with genes and metabolic pathways that would lead to improved photobiological hydrogen production. Despite the substantial research involving microorganisms, only a small fraction of the world's vast supply of microorganisms have been identified, cultivated, and functionally characterized. Research should take into consideration ongoing "bioprospecting" efforts to collect, identify, and characterize microorganisms in various basic research programs. Though many of these efforts do not directly test for hydrogen production, other reported characteristics may be useful, either for required characteristics not directly related to hydrogen production (e.g., robust growth at a range of temperatures) or through correlation to

hydrogen production (e.g., related metabolic pathways). Metagenomics sampling, in which DNA is isolated from an environmental sample without the need to cultivate the microorganisms, has produced gene libraries that can be analyzed to identify novel genes related to hydrogen production.¹²³ Leveraging the rapidly expanding libraries of organisms and genes will facilitate development of promising microbes for hydrogen production.¹²⁴

The conversion efficiency of incident light to electrons is low in unmodified organisms, resulting in approximately 3% of the available sunlight being converted into chemical energy that can be used by the cell,¹²⁵ which significantly limits the potential hydrogen production efficiency. Light is harnessed in the microorganisms by the relatively large arrays of light-capturing antenna pigment molecules. Under bright sunlight, pigment antennae absorb much more light than can be utilized by the photosynthetic electron transport apparatus of the organism, resulting in up to 80% of the absorbed sunlight being lost through heat dissipation.¹²⁶ The technology readiness efficiency target for photolytic light utilization is 30% for green algae; the current status is 25% for a modified algae strain.¹²⁷ Further improvements to 54% may be possible by extending the range of wavelengths that can be collected by a single cell through genetic engineering to develop a microorganism with multiple light collection systems.¹²⁸

Significant improvement in production is required to make this technology commercially viable.¹²⁹ The current STH conversion efficiencies are less than 1% for full sunlight conditions, while the DOE technical target is 17% for a system that could meet the threshold cost goal.¹³⁰ The low conversion efficiencies have been attributed to a number of issues. These issues include (1) the non-dissipation of a proton gradient across the photosynthetic membrane, which occurs when hydrogen ions produced through water splitting are not released from the photosynthetic compartment of the cell and are thus sequestered away from the hydrogenase enzyme, and (2) the existence of competing pathways for the substrates for hydrogen production (i.e., the microorganisms making other products in addition to hydrogen).^{131,132} Further, many

¹²³ G. Maroti et al., “Discovery of [NiFe] Hydrogenase Genes in Metagenomic DNA: Cloning and Heterologous Expression in *Thiocapsa roseopersicina*,” *Applied and Environmental Microbiology* (September 2009): 5821–5830.

¹²⁴ Ibid.

¹²⁵ R. E. Blankenship et al., “Comparing photosynthetic and photovoltaic efficiencies and recognizing the potential for improvement,” *Science* 332, no. 6031 (13 May 2011): 805–9, doi: 10.1126/science.1200165; A. Melis, “Photosynthesis-to-fuels: from sunlight to hydrogen, isoprene, and botryococcene production,” *Energy Environ. Sci.* 5 (2012): 5531–5539, doi: 10.1039/C1EE02514G.

¹²⁶ Ibid; P. C. Hallenbeck, M. Abo-Hashesh, and D. Ghosh, “Strategies for improving biological hydrogen production,” *Bioresour Technol.* 110 (April 2012): 1–9, doi: 10.1016/j.biortech.2012.01.103.

¹²⁷ H. Kirst et al., “Truncated Photosystem Chlorophyll Antenna Size in the Green Microalga *Chlamydomonas reinhardtii* upon Deletion of the TLA3-CpSRP43 Gene,” *Plant Physiol.* 160, no. 4 (December 2012): 2251–60, doi: 10.1104/pp.112.206672.

¹²⁸ R. E. Blankenship et al., “Comparing photosynthetic and photovoltaic efficiencies and recognizing the potential for improvement,” *Science* 332, no. 6031 (13 May 2011): 805–9, doi: 10.1126/science.1200165; Office of Energy Efficiency and Renewable Energy, *Fuel Cell Technologies Office Multi-Year Research, Development, and Demonstration Plan* (Washington, DC: U.S. Department of Energy, November 2012), Section 3.1, www1.eere.energy.gov/hydrogenandfuelcells/mypp/.

¹²⁹ P. C. Hallenbeck, M. Abo-Hashesh, and D. Ghosh, “Strategies for improving biological hydrogen production,” *Bioresour Technol.* 110 (April 2012): 1–9, doi: 10.1016/j.biortech.2012.01.103; B. D. James et al., *Technoeconomic Boundary Analysis of Biological Pathways to Hydrogen Production*, NREL/SR-560-46674, produced by Directed Technologies Inc., Arlington, VA (Golden, CO: National Renewable Energy Laboratory, September 2009), <http://www1.eere.energy.gov/hydrogenandfuelcells/pdfs/46674.pdf>.

¹³⁰ Office of Energy Efficiency and Renewable Energy, *Fuel Cell Technologies Office Multi-Year Research, Development, and Demonstration Plan* (Washington, DC: U.S. Department of Energy, November 2012), Section 3.1, www1.eere.energy.gov/hydrogenandfuelcells/mypp/.

¹³¹ M. L. Ghirardi et al., “Photobiological hydrogen-producing systems,” *Chem Soc Rev.* 38, no. 1 (January 2009):52–61, doi: 10.1039/b718939g; Review, Erratum in *Chem Soc Rev.* 38, no. 12 (December 2009):3505.

¹³² W. S. Kontur, D. R. Noguera, and T. J. Donohue, “Maximizing reductant flow into microbial H₂ production,” *Curr Opin Biotechnol.* 23, no. 3 (June 2012): 382–9, doi: 10.1016/j.copbio.2011.10.003.

photosynthetic bacteria and cyanobacteria contain enzymes that consume produced hydrogen to support cell growth. The enzymes, known as uptake hydrogenase enzymes, inhibit net hydrogen accumulation.¹³³

Like all solar-based production methods, photobiological processes are discontinuous because they depend on sunlight. One possible solution is to extend the hydrogen-producing period past daylight hours by engineering a system in which the cells store photosynthetically generated sugars and starches during the day, which are subsequently converted to hydrogen using dark fermentation when there is low or no light.¹³⁴ Because of the added steps, this “indirect photobiological” production is less efficient, and the benefits of extending hydrogen production must be balanced with the reduced efficiency.

Photolytic Barriers

The duration of photolytic biological production is severely limited, primarily by the oxygen sensitivity of the hydrogenase enzyme in the algae and cyanobacteria characterized to date.¹³⁵ Though some of the enzymes used in photofermentation are oxygen-sensitive, oxygen sensitivity is a particular problem for photolytic processes because of the co-production of oxygen and hydrogen. In addition, when the organism senses oxygen, the microbe stops producing hydrogen and initiates other metabolic processes. Key barriers to oxygen tolerance include (1) the oxygen sensitivity of the enzymes, (2) the lack of separation in the oxygen and the hydrogen production cycles, and (3) the P/R ratio, which if greater than 1, causes oxygen to accumulate in the medium. This barrier to continuous production must be removed to achieve the technology readiness target of at least eight hours of continuous production in air at full light conditions.¹³⁶

Green algae and cyanobacteria will become anaerobic if a low P/R is maintained. Under these conditions, photosynthetic water oxidation produces hydrogen instead of starch, and the oxygen evolved by photosynthesis is consumed by respiration to produce carbon dioxide. This has the advantage of both increasing hydrogen production and reducing the problems associated with oxygen co-production. Currently, reducing this ratio is achieved by nutrient deprivation that limits photosynthesis, limiting the solar-to-hydrogen conversion efficiency and therefore the system’s economic viability.¹³⁷ Alternative mechanisms need to be developed that bring the P/R to 1 without reducing the efficiency of photosynthesis.

Co-production of oxygen and hydrogen presents safety issues that need to be addressed either through molecular engineering to reduce the levels of co-produced oxygen or through systems engineering to separate the oxygen from the hydrogen.

¹³³ M. L. Ghirardi et al., “Photobiological hydrogen-producing systems,” *Chem Soc Rev.* 38, no. 1 (January 2009): 52–61, doi: 10.1039/b718939g; Review, Erratum in *Chem Soc Rev.* 38, no. 12 (December 2009): 3505.

¹³⁴ M. D. Redwood, M. Paterson-Beedle, and L. E. Macaskie, “Integrating dark and light biohydrogen production strategies: towards the hydrogen economy,” *Reviews in Environmental Science and Bio/Technology* 8, no. 2 (2009): 149–185.

¹³⁵ M. L. Ghirardi et al., “Photobiological hydrogen-producing systems,” *Chem Soc Rev.* 38, no. 1 (January 2009): 52–61, doi: 10.1039/b718939g; Review, Erratum in *Chem Soc Rev.* 38, no. 12 (December 2009): 3505; P. C. Hallenbeck, M. Abo-Hashesh, and D. Ghosh, “Strategies for improving biological hydrogen production,” *Bioresour Technol.* 110 (April 2012): 1–9, doi: 10.1016/j.biortech.2012.01.103.

¹³⁶ Office of Energy Efficiency and Renewable Energy, *Fuel Cell Technologies Office Multi-Year Research, Development, and Demonstration Plan* (Washington, DC: U.S. Department of Energy, November 2012), Section 3.1, www1.eere.energy.gov/hydrogenandfuelcells/mypp/.

¹³⁷ B. D. James et al., *Technoeconomic Boundary Analysis of Biological Pathways to Hydrogen Production*, NREL/SR-560-46674, produced by Directed Technologies Inc., Arlington, VA (Golden, CO: National Renewable Energy Laboratory, September 2009), <http://www1.eere.energy.gov/hydrogenandfuelcells/pdfs/46674.pdf>; T. K. Antal, T. E. Krendeleva, and A. B. Rubin, “Acclimation of green algae to sulfur deficiency: underlying mechanisms and application for hydrogen production,” *Appl Microbiol Biotechnol* 89, no. 1 (Jan. 2011): 3–15, doi: 10.1007/s00253-010-2879-6.

Photofermentative Bacterial Hydrogen Production

Photofermentative production of hydrogen could potentially rely on photosynthesis for the generation of organic compounds for fermentation to hydrogen, but rates and efficiencies would be much lower than for photofermentative organisms provided with an organic feedstock. Photofermentative bacteria can metabolize a variety of organic substrates, such as waste by-products of various fermentative processes. However, the metabolism of compounds such as acetic and lactic acids for production of hydrogen also generates by-products. Synthesis of these by-products by certain metabolic pathways competes with hydrogen production for the same source of electron donors. Waste products may also inhibit growth. Nitrogenases require energy provided by ATP, reducing the efficiency of hydrogen production. Photofermentation systems become saturated at low light levels, so while the efficiency is around 4% at low light levels, it is less than 1% at full light levels.¹³⁸ This is below the DOE 2015 target of 3% efficiency at full light levels.¹³⁹

Because nitrogenase produces hydrogen only in the absence of nitrogen, the C/N ratio strongly influences nitrogenase activity. This ratio must be properly maintained at a high level for maximum hydrogen production. In systems integrating multiple technologies, in which the product from a dark fermenter is used as the feed to the photosynthetic reactor, the C/N ratio will be negatively impacted. Bacteria need to be identified or engineered that are capable of suitable operation using a wider C/N ratio than currently possible for available bacteria.¹⁴⁰

Combined Biological System

In addition to the barriers associated with each individual pathway, combined biological systems face challenges in integrating multiple production methods. Co-cultivating oxygenic photosynthetic organisms with anoxygenic photosynthetic bacteria to extend the absorption spectrum of the hydrogen photoproducing cultures to the infrared (700-1000 nm) should be investigated.¹⁴¹ However, photosynthetic bacteria also absorb light in the visible region (400-600 nm), thus potentially competing with green algae for these latter wavelengths. Developing and maintaining the appropriate biomass ratio of the two organisms, as suspensions in the same cultures or separating them in the same photoreactor via immobilization of one or both cultures, will be necessary for the successful development of such systems. An alternative to co-culture balancing would be to engineer an organism with the light absorption properties of both green photolytic species and photosynthetic bacteria.¹⁴²

Biomass feedstock utilization must also be optimized. In a combined system in which organisms are co-cultured, competition for the organic carbon substrates between two organisms in the same medium will be an issue. In sequential systems, the ability of each stage to utilize the exogenous carbon sources

¹³⁸ M. D. Redwood, M. Paterson-Beedle, and L. E. Macaskie, "Integrating dark and light biohydrogen production strategies: towards the hydrogen economy," *Reviews in Environmental Science and Bio/Technology* 8, no. 2 (2009): 149–185; P. C. Hallenbeck, M. Abo-Hashesh, and D. Ghosh, "Strategies for improving biological hydrogen production," *Bioresour Technol.* 110 (April 2012): 1–9, doi: 10.1016/j.biortech.2012.01.103.

¹³⁹ Office of Energy Efficiency and Renewable Energy, *Fuel Cell Technologies Office Multi-Year Research, Development, and Demonstration Plan* (Washington, DC: U.S. Department of Energy, November 2012), Section 3.1, www1.eere.energy.gov/hydrogenandfuelcells/mypp/.

¹⁴⁰ M. L. Ghirardi et al., "Photobiological hydrogen-producing systems," *Chem Soc Rev.* 38, no. 1 (January 2009): 52–61, doi: 10.1039/b718939g; Review, Erratum in *Chem Soc Rev.* 38, no. 12 (December 2009): 3505; P. C. Hallenbeck, M. Abo-Hashesh, and D. Ghosh, "Strategies for improving biological hydrogen production," *Bioresour Technol.* 110 (April 2012): 1–9, doi: 10.1016/j.biortech.2012.01.103.

¹⁴¹ M. L. Ghirardi et al., "Photobiological hydrogen-producing systems," *Chem Soc Rev.* 38, no. 1 (January 2009): 52–61, doi: 10.1039/b718939g; Review, Erratum in *Chem Soc Rev.* 38, no. 12 (December 2009): 3505.

¹⁴² R. E. Blankenship et al., "Comparing photosynthetic and photovoltaic efficiencies and recognizing the potential for improvement," *Science* 332, no. 6031 (13 May 2011): 805–9, doi: 10.1126/science.1200165.

supplied from other stages will need to be addressed. Each system will need to be appropriately scaled to provide sufficient feedstock for the next.

System Design

Photobiological systems face a number of system design barriers in addition to the common system design issues of all hydrogen production systems. Photobioreactor designs and materials for all applications are in early development. Unlike designs for liquid biofuels and bioproducts, hydrogen photobioreactors must use closed systems rather than open ponds to allow collection of the hydrogen gas. Innovative, cost-effective methods to collect and purify the hydrogen may need to be developed to safely remove the oxygen (in the case of photolytic production), to rapidly remove evolved hydrogen (which can inhibit further hydrogen production), and to remove other contaminants. Biological hydrogen systems must provide for continuous monitoring and maintenance of reactor temperature, pH, microbe compositions, feed concentrations, waste products, and any other conditions required to maintain the health of the microorganisms. Materials that are transparent, compatible with microorganism growth, and non-reactive to the microbial products (hydrogen, organic waste products) must be developed.

Since photobiological hydrogen production is in an early development stage, opportunities exist to develop the materials and microorganisms for a system that will minimize O&M costs and activities. Because of the photobiological hydrogen systems’ relatively early stage of development, it is expected that commercial-scale photobiological biofuel and bioproduct systems will be developed before the photobiological hydrogen systems. Therefore, photobiological hydrogen systems will be able to leverage the developments made in areas such as photobioreactor design, large-scale microorganism culturing conditions, and methods to address and mitigate safety and environmental concerns.

7.3 Strategy to Overcome Barriers and Achieve Technical Targets

Table 7.3 lists critical technology needs for biological hydrogen production. A discussion of these efforts follows. Note that a single R&D activity may address more than one barrier, and multiple R&D activities may be needed to address a single barrier.

Table 7.3. Photobiological Hydrogen Production — Critical Technology Needs

<p>Identify and Optimize Microorganism Hydrogen Production Rates</p>	<ul style="list-style-type: none"> ➔ Identify naturally occurring strains, genes, or enzymes with improved hydrogen production characteristics (leverage basic research) and apply knowledge to improving hydrogen production of other strains ➔ Increase duration of hydrogen production using molecular biology, genetic engineering, and other microbiology techniques ➔ Engineer methods to increase the conversion of collected light energy to hydrogen through improved kinetics and optimization of cellular metabolic pathways ➔ Reduce or eliminate metabolic activities that compete with hydrogen production for substrates ➔ Identify or engineer methods to improve light utilization efficiency ➔ Integrate the optimal microorganism characteristics into a single organism ➔ Develop methods to scale up lab-scale designs to large-scale cultivation systems
<p>Innovative Photobioreactor Design</p>	<ul style="list-style-type: none"> ➔ Leverage ongoing research on large-scale cultivation methods and photobioreactor designs (e.g., funded through the DOE Bioenergy Technologies Office) ➔ Identify and/or develop appropriate materials for photobioreactors that are compatible with microorganisms and hydrogen
<p>Technoeconomic Analysis</p>	<ul style="list-style-type: none"> ➔ Develop detailed technoeconomic models of prospective photobioreactors based on promising microbial systems and reactor designs under development to guide R&D efforts toward meeting H₂ cost threshold

Addressing all of the barriers to meet commercialization cost targets for photobiological hydrogen production will require simultaneous R&D efforts in several areas, along with efforts to develop policy, standards, and delivery infrastructure technology. Although these efforts are taking place concurrently, the impact of each effort on the entire hydrogen production system must be kept in mind and integrated into systems optimization efforts.

Development of microorganisms that can continually produce high amounts of hydrogen is the highest near-term priority. There are several activities to be needed: increasing the conversion of photosynthetic energy to hydrogen production, reducing competing pathways, and improving the collection of light and its conversion to energy that the cells can use. In photolytic production, continuous production, currently limited by oxygen sensitivity, is a major barrier; and for photofermentative systems, efficient conversion of low-cost organic feedstocks must be developed. In the longer term, cultivation methods must be scaled up from the current bench scale. Photobioreactors with economical capital and operating costs will also need to be developed; this will likely heavily leverage current development efforts by groups such as the Bioenergy Technologies Office.

8.0 Fermentation

The fermentation pathway calls for using microorganisms that break down biomass to produce hydrogen as a metabolic product or through microbe-aided electrolysis. This is a mid- to long-term technology that will most likely be suitable for distributed, semi-central, and central hydrogen production facilities, depending on the feedstock used.

8.1 Current Status and Technical Targets

Pathways for fermentative hydrogen production include traditional dark fermentation and microbial-aided electrolysis. In dark fermentation, bacteria decompose biomass into hydrogen and by-products without the need for sunlight.¹⁴³ Microbial electrolysis combines the energy from microbial decomposition of organic matter with an additional small electric current to produce hydrogen;¹⁴⁴ the term microbial electrolysis cell (MEC) will be used in this document to encompass all the related system designs.

Hydrogen fermentation and MECs are in an early phase of development, requiring both fundamental and applied R&D. Perhaps the nearest-term opportunity for these technologies is a system that produces a usable fuel by using industrial, municipal or agricultural wastes as a feedstock. Pilot systems using these feedstocks currently exist for both fermentation and MECs, but hydrogen yields and rates are both low.¹⁴⁵ These systems may be made feasible by offsetting other costs, even if hydrogen production yields and rates are low. For example, systems that utilize a waste stream could become economical, in part, by replacing costly wastewater treatment processes while producing a valuable fuel.¹⁴⁶

Dark Fermentation

Dark fermentation uses anaerobic bacteria on carbohydrate-rich substrates grown, as the name indicates, without the need for light. As the microbes break down the biomass substrate, a number of pathways can result in hydrogen production.¹⁴⁷ Strains with the enzyme formate hydrogen lyase (FHL) can convert formate (HCO_2^-) to H_2 and CO_2 . Other hydrogenases use the reduced forms of the electron donors, ferredoxin or NADH (the

Fermentative Hydrogen Production



Feedstock:	Water Biomass
Energy Source:	Solar Biomass
Production:	Distributed Semi-Central Central

Environmental Benefits

Research in biological hydrogen has progressed in recent years with increased focus on sustainability. In the long term, these technologies may provide economical hydrogen production with low-carbon emissions.

¹⁴³ W. S. Kontur, D. R. Noguera, and T. J. Donohue, "Maximizing reductant flow into microbial H_2 production," *Curr Opin Biotechnol.* 23, no. 3 (June 2012): 382–9, doi: 10.1016/j.copbio.2011.10.003; P. C. Hallenbeck, M. Abo-Hashesh, and D. Ghosh, "Strategies for improving biological hydrogen production," *Bioresour Technol.* 110 (April 2012): 1–9, doi: 10.1016/j.biortech.2012.01.103.

¹⁴⁴ B. E. Logan, *Microbial Fuel Cells* (New York: John Wiley & Sons, 2008).

¹⁴⁵ R. D. Cusick et al., "Performance of a pilot-scale continuous flow microbial electrolysis cell fed winery wastewater," *Appl Microbiol Biotechnol* 89, no. 6 (March 2011): 2053–63, doi: 10.1007/s00253-011-3130-9; T. M. Vatsala, Raj S. Mohan, and A. Manimaran, "A pilot-scale study of biohydrogen production from distillery effluent using defined bacterial co-culture," *International Journal of Hydrogen Energy* 33, no. 20 (October 2008): 5404–5415, <http://www.sciencedirect.com/science/article/pii/S0360319908008367>.

¹⁴⁶ M. L. Chonga et al., "Biohydrogen production from biomass and industrial wastes by dark fermentation," *International Journal of Hydrogen Energy* 34, no. 8 (May 2009): 3277–3287.

¹⁴⁷ W. S. Kontur, D. R. Noguera, and T. J. Donohue, "Maximizing reductant flow into microbial H_2 production," *Curr Opin Biotechnol.* 23, no. 3 (June 2012): 382–9, doi: 10.1016/j.copbio.2011.10.003; P. C. Hallenbeck, M. Abo-Hashesh, and D.

reduced form of nicotinamide adenine dinucleotide), to supply the necessary electrons to produce hydrogen. Many different metabolic steps are needed to either reduce or oxidize these electron carriers, depending on the initial feedstock and other conditions. Some by-products of this metabolism, such as organic acids, may be broken down further by microbes for energy but would not produce reduced ferredoxin or NADH, and therefore would not result in hydrogen production.

For large-scale fermentative processes to be efficient, the biomass feedstock used needs to be bioavailable, available in large quantities with consistent supply and quality, inexpensive, and possess high carbohydrate content. Pure, simple sugars (such as glucose and lactose) are easily biodegradable but are more expensive and must be refined from biomass sources, so microorganisms are now being developed that can use other, less costly, feedstocks, including wastes.¹⁴⁸ Hydrogen production rates and yields vary widely for different feedstocks, but as an example, fermentation of cellulose yielded 3.2 moles H₂/mole equivalent of glucose.¹⁴⁹ Using known metabolic pathways, a maximum of 4 moles H₂/mole of glucose can be produced. Industrial-scale fermentation for other products is well-developed, so although fermentation to produce hydrogen would have unique requirements, many of the necessary components have been developed and are available at large scales.

Microbial Electrolysis Cells

MECs are a variation of microbial fuel cells. In microbial fuel cells, a microbial culture decomposes organic matter, excreting protons and transferring electrons to the anode; the electrons travel to the cathode and combine with oxygen and the protons to produce water, along with a low voltage.¹⁵⁰ In an MEC, a small voltage is added, resulting in the recombination at the cathode to produce hydrogen gas instead of water (Figure 8.). With the bacteria breaking down the organic matter to electrons and protons and generating power, little external electric power is required relative to standard water electrolysis. In theory, an MEC using acetate as a feedstock needs as little as 0.114 V to generate hydrogen, though in practice around 0.25 V or more must be applied.¹⁵¹ In comparison, water electrolysis systems theoretically require 1.23 V to split water and, in practice, usually require 1.6-2.0 V to produce hydrogen. Because the microbial contribution is not dependent on ferredoxin or NADH, MECs can use feedstocks that would not support fermentative hydrogen production. Though carbon dioxide is produced at the anode through the metabolic processing, reactor designs can be made to ensure that the gas collected at the cathode is nearly pure hydrogen.

For both fermentative and MEC hydrogen production, current microbial strains do not yet meet the production rates needed to meet the threshold cost goal for production: \$1-\$2/gge. There are ongoing efforts to improve the current strains and conditions, as well as to identify organisms with improved characteristics. In recent years, the number of microorganisms identified for potential use in these

Ghosh, "Strategies for improving biological hydrogen production," *Bioresour Technol.* 110 (April 2012): 1–9, doi: 10.1016/j.biortech.2012.01.103.

¹⁴⁸ M. L. Chonga et al., "Biohydrogen production from biomass and industrial wastes by dark fermentation," *International Journal of Hydrogen Energy* 34, no. 8 (May 2009): 3277–3287; N. Ren et al., "Biohydrogen production from molasses by anaerobic fermentation with a pilot-scale bioreactor system," *International Journal of Hydrogen Energy* 31, no. 15 (December 2006): 2147–2157, <http://www.sciencedirect.com/science/article/pii/S0360319906000814>.

¹⁴⁹ Office of Energy Efficiency and Renewable Energy, *Fuel Cell Technologies Office Multi-Year Research, Development, and Demonstration Plan* (Washington, DC: U.S. Department of Energy, November 2012), Section 3.1, www1.eere.energy.gov/hydrogenandfuelcells/mypp/.

¹⁵⁰ B. E. Logan, *Microbial Fuel Cells* (New York: John Wiley & Sons, 2008).

¹⁵¹ Ibid.

technologies has increased substantially.¹⁵² Only a small fraction of naturally occurring microorganisms have been discovered and functionally characterized. For example, while estimates of the number of

prokaryotic species (bacteria and archaea) are in the millions, only about 4,500 have been characterized.¹⁵³ Research is ongoing to discover strains with the necessary characteristics. Optimal growth conditions (e.g., pH, temperature, feedstock loading) for high hydrogen production rates and yields are under study.¹⁵⁴ Known organisms are being modified to improve their characteristics.¹⁵⁵ Several recent review articles provide in-depth descriptions of the reaction pathways and types of enzymes being used in studies of biological hydrogen production.¹⁵⁶

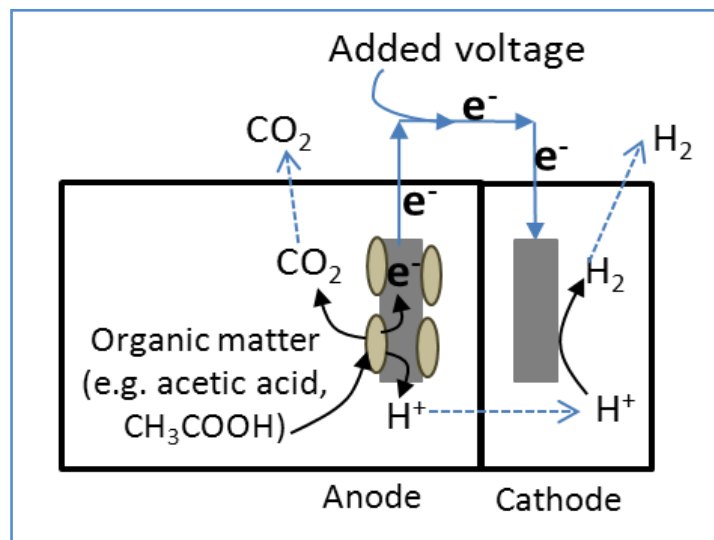

Figure 8.1. Microbial Electrolysis Cell

Combined Systems

Integration of different technologies may make it possible to create an economically and technically viable system without overcoming all of the individual technology barriers. The dark fermentative bacteria in a reactor consume biomass to produce hydrogen and small organic molecules, which the bacteria are unable to further degrade to hydrogen using known metabolic pathways.¹⁵⁷ The organic waste products from the dark fermentative reactor may then be used as feedstock for the MEC reactor, resulting in production of hydrogen from the biomass feedstock at levels approaching the stoichiometric maximum for the combined system. An integrated biological system increases the total hydrogen production capability vs. stand-alone, single-technology systems because the total hydrogen produced is greater.

Both fermentation and MEC systems have the potential, alone or in combination, to be integrated with waste treatment systems in which a bioavailable waste product (food waste, sewage, etc.) could act as the

¹⁵² G. Davila-Vazquez et al., “Fermentative biohydrogen production: trends and perspectives,” *Reviews in Environmental Science and Bio/Technology* 7, no. 1 (January 2008): 27–45; S. Rittmann and C. Herwig, “A comprehensive and quantitative review of dark fermentative biohydrogen production,” *Microb Cell Fact.* 11 (August 27, 2012): 115, doi: 10.1186/1475-2859-11-115.

¹⁵³ Vigdis Torsvik, Lise Øvreås, and Tron Frede Thingstad, “Prokaryotic Diversity — Magnitude, Dynamics, and Controlling Factors,” *Science* 296, no. 5570 (May 10, 2002): 1064–1066.

¹⁵⁴ G. Davila-Vazquez et al., “Fermentative biohydrogen production: trends and perspectives,” *Reviews in Environmental Science and Bio/Technology* 7, no. 1 (January 2008): 27–45; S. Rittmann and C. Herwig, “A comprehensive and quantitative review of dark fermentative biohydrogen production,” *Microb Cell Fact.* 11 (August 27, 2012): 115, doi: 10.1186/1475-2859-11-115.

¹⁵⁵ P. C. Maness, “Fermentation and Electrohydrogenic Approaches to Hydrogen Production” (2012 Annual Merit Review Presentation, May 16, 2012), http://www.hydrogen.energy.gov/pdfs/review12/pd038_maness_2012_o.pdf.

¹⁵⁶ W. S. Kontur, D. R. Noguera, and T. J. Donohue, “Maximizing reductant flow into microbial H₂ production,” *Curr Opin Biotechnol.* 23, no. 3 (June 2012): 382–9, doi: 10.1016/j.copbio.2011.10.003; P. C. Hallenbeck, M. Abo-Hashesh, and D. Ghosh, “Strategies for improving biological hydrogen production,” *Bioresour Technol.* 110 (April 2012): 1–9, doi: 10.1016/j.biortech.2012.01.103; G. Davila-Vazquez et al., “Fermentative biohydrogen production: trends and perspectives,” *Reviews in Environmental Science and Bio/Technology* 7, no. 1 (January 2008): 27–45; M. D. Redwood, M. Paterson-Beedle, and L. E. Macaskie, “Integrating dark and light biohydrogen production strategies: towards the hydrogen economy,” *Reviews in Environmental Science and Bio/Technology* 8, no. 2 (2009): 149–185.

¹⁵⁷ P. C. Hallenbeck, M. Abo-Hashesh, and D. Ghosh, “Strategies for improving biological hydrogen production,” *Bioresour Technol.* 110 (April 2012): 1–9, doi: 10.1016/j.biortech.2012.01.103.

feedstock.¹⁵⁸ Such a system could reduce the net costs of hydrogen production by replacing costly wastewater treatments with a system that could both treat waste and produce a useable by-product. In this case, production could occur on a distributed or semi-central scale with the reactor systems installed at the site of waste production. Different waste products would have different challenges with respect to feedstock utilization and may have lower stoichiometric hydrogen yields, but the economic and sustainability considerations may allow this production pathway to reach commercial viability earlier than other biological production pathways.

The DOE goal for biological hydrogen production is to use rational design, strain development, and optimization to advance these varied production pathways and achieve the DOE hydrogen production cost targets necessary to become competitive with other renewable production pathways. This roadmap identifies knowledge and technological gaps and outlines strategies for addressing them to support development of low-cost, highly efficient, fermentative hydrogen production technologies.

DOE Cost Targets

DOE's research supports the goal of mid- to long-term commercial hydrogen production using fermentation and MEC technologies using renewable feedstocks at costs ultimately competitive with other renewable production methods. DOE's current R&D focus for fermentative hydrogen production is on improving hydrogen production rates and integrating hydrogen production methods with long-established industrial fermentation technologies for commercial scale-up. Current and future cost projections specific to fermentation have not been completed, and therefore specific cost targets have not been defined by DOE. The cost target listed in Table 8.1 is a general target for all biological hydrogen production pathways. This roadmap addresses initial development needs, as well as obstacles that will need to be avoided or minimized to reduce time to deployment. The current research objective is to verify the feasibility of using fermentation systems to produce cost-competitive hydrogen in the long term.

Table 8.1. Biological Hydrogen Production — DOE Cost Target¹⁵⁹

Year	Production Scale	Cost/gge (produced)
2020 Target	Semi-central	\$10.00

8.2 Gaps and Technical Barriers

DOE's research activities are being driven by specific barriers identified in the MYRD&D,¹⁶⁰ as well as others identified by the U.S. DRIVE Partnership's HPTT. Barriers facing cost-effective fermentative and MEC hydrogen production are summarized in Table 8.2 and described more fully on the following pages.

¹⁵⁸ B. E. Logan, *Microbial Fuel Cells* (New York: John Wiley & Sons, 2008); M. L. Chonga et al., "Biohydrogen production from biomass and industrial wastes by dark fermentation," *International Journal of Hydrogen Energy* 34, no. 8 (May 2009): 3277–3287; N. Ren et al., "Biohydrogen production from molasses by anaerobic fermentation with a pilot-scale bioreactor system," *International Journal of Hydrogen Energy* 31, no. 15 (December 2006): 2147–2157, <http://www.sciencedirect.com/science/article/pii/S0360319906000814>.

¹⁵⁹ Office of Energy Efficiency and Renewable Energy, Fuel Cell Technologies Office Multi-Year Research, Development, and Demonstration Plan (Washington, DC: U.S. Department of Energy, November 2012), Section 3.1, <http://www1.eere.energy.gov/hydrogenandfuelcells/mypp/>.

¹⁶⁰ Ibid.

Table 8.2. Fermentative and MEC Hydrogen Production — Summary of Barriers

Microorganism Characterization	Lack of Identified Species and Consortia: The organisms and pathways that have been characterized so far do not have the characteristics needed to meet DOE targets. Though microorganisms may exist in nature with better characteristics, many of the naturally occurring microorganisms and consortia (mixed populations of multiple species) with desirable properties are not well characterized.
	Condition Characterization: The effects of different conditions (e.g., temperature, feedstock concentration, hydraulic retention time [HRT]) on hydrogen production must be characterized.
	Tool Development: Many of the promising microorganisms do not have well-established genetic and molecular biology tools available. These tools will need to be developed to allow strain optimization.
Dark Fermentation	Hydrogen Production Yields and Rates: Hydrogen yield and production rates are both too low. Methods to increase yield and production must be developed. Trade-offs between yield and rate must be identified and considered.
	Waste By-products: Waste by-products (e.g., butyric acid and ethanol) may compete with hydrogen production in fermentation and/or inhibit further hydrogen production. Metabolic pathways that reduce the production of waste acids, or methods to utilize these waste acids, must be identified or developed.
	Feedstock Issues: Feedstock is a major cost driver for hydrogen production using this technology. Refined sugars such as glucose may result in a higher molar yield but are expensive. Pathways and microbes for using lower-cost feeds must be identified.
	Reactor Systems: Reactor systems will need to be developed to remove and separate the hydrogen gas from the reactor headspace. Materials that are hydrogen-compatible may need to be incorporated into current industrial-scale reactor system designs.
MECs	Biological System Performance: Evaluation of different microbial communities that enable improved hydrogen production need to be evaluated, and conditions that best balance production rates and total yields with reactor performance must be identified.
	Material Development: This technology uses materials similar to electrolyzers in conjunction with microbes for the anode. Novel durable cathodes and non-precious metal catalysts are needed for the cathode to enhance hydrogen evolution. Lower-cost materials and/or multifunctional materials are being identified and evaluated for long-term performance and need to be tested for larger-scale systems.
	Reactor Design: Laboratory-scale reactors are not sufficient for commercially viable hydrogen production. Issues relating to the scale-up of the reactor will be barriers to maximizing hydrogen production while minimizing cost and maintenance.
	Feedstock Issues: This technology has been shown to operate on acetic acid and several other volatile acids (commonly produced as fermentation end products), glucose, and cellulose, and other sources of organic matter (e.g., municipal and industrial wastewater). Systems that can reach high yields and production rates using low-cost, abundant feedstocks are needed to improve the economics of hydrogen production.
	Systems Engineering: The feasibility of using non-grid sources of electricity for the required supplement should be explored to make the process more sustainable. Methods to collect evolved carbon dioxide and hydrogen separately must be considered.

Microorganism Characterization

In order to develop fermentation and MEC systems that can meet DOE targets, more characterization is needed for microbial strains or consortia (mixtures of microbes, often isolated from sources such as sewage sludge) with desirable characteristics.¹⁶¹ Further characterization of individual strains and successful consortiums are needed to better understand the characteristics and interactions that result in improved hydrogen production, as well as to aid the development of molecular biology tools (e.g., plasmid systems for genetic engineering) to further improve hydrogen production rates and yields. Bioprospecting efforts and the recent development of large genetic libraries may be useful resources for fermentation and MEC research and development.

Dark Fermentative Hydrogen Production

Current microbial strains are not able to produce the maximum theoretical hydrogen yield from biomass. For example, the maximum hydrogen content based on glucose's chemical components is 12 moles of H₂/mole glucose. However, known biological pathways can theoretically produce up to 4 moles H₂/mole glucose and, in practice, 2 moles H₂/mole glucose are generated.¹⁶² Current pathways and metabolic engineering do not yield microorganisms that are able to directly take advantage of the 12 mole maximum yield potential. The ultimate goal of this technology pathway is to generate 10 moles H₂/mole glucose, or the equivalent yield for other carbohydrates. Limiting factors include metabolic by-product accumulation, including waste acids and solvents, and competing metabolic pathways.

Fermentation produces by-products, such as acetic and butyric acids and ethanol.¹⁶³ The production of these products poses several challenges, such as lowering the molar yield of hydrogen by diverting the metabolic substrates away from hydrogen production and requiring wastewater treatment.

For renewable hydrogen to be competitive with other transportation fuels, the costs related to feedstocks must be reduced,¹⁶⁴ through a combination of utilizing lower-cost feedstocks (for example, raw biomass or reduced-cost sugars), reducing processing steps, and improving the hydrogen yield from a given feedstock. Currently available cellulolytic microbes and other organisms do best with relatively pure feedstocks and still have insufficient yields. This lack of flexibility drives up feedstock costs. For raw biomass, seasonal availability must also be considered.

Though fermentation technology is well-established, systems will need to be designed that support the conditions that maximize microbial hydrogen production¹⁶⁵ and that allow efficient handling of the hydrogen product. Systems to collect products and separate hydrogen from carbon dioxide and any other components will need to be incorporated. Prevention of methanogen contamination is also required. Methanogens are single-cell, anaerobic microorganisms, often found in the same environments as bacteria

¹⁶¹ G. Davila-Vazquez et al., "Fermentative biohydrogen production: trends and perspectives," *Reviews in Environmental Science and Bio/Technology* 7, no. 1 (January 2008): 27–45; S. Rittmann and C. Herwig, "A comprehensive and quantitative review of dark fermentative biohydrogen production," *Microb Cell Fact.* 11 (August 27, 2012): 115, doi: 10.1186/1475-2859-11-115.

¹⁶² P. C. Hallenbeck, M. Abo-Hashesh, and D. Ghosh, "Strategies for improving biological hydrogen production," *Bioresource Technol.* 110 (April 2012): 1–9, doi: 10.1016/j.biortech.2012.01.103.

¹⁶³ Ibid.

¹⁶⁴ B. D. James et al., *Technoeconomic Boundary Analysis of Biological Pathways to Hydrogen Production*, NREL/SR-560-46674, produced by Directed Technologies Inc., Arlington, VA (Golden, CO: National Renewable Energy Laboratory, September 2009), <http://www1.eere.energy.gov/hydrogenandfuelcells/pdfs/46674.pdf>.

¹⁶⁵ G. Davila-Vazquez et al., "Fermentative biohydrogen production: trends and perspectives," *Reviews in Environmental Science and Bio/Technology* 7, no. 1 (January 2008): 27–45; S. Rittmann and C. Herwig, "A comprehensive and quantitative review of dark fermentative biohydrogen production," *Microb Cell Fact.* 11 (August 27, 2012): 115, doi: 10.1186/1475-2859-11-115.

used in dark fermentation; these microorganisms produce methane by consuming the hydrogen and carbon dioxide released by the dark fermentation process.

Microbial Electrolysis Cell Hydrogen Production

Electrochemically active microbes have been discovered relatively recently.¹⁶⁶ The mechanisms for electron transfer from the microbe to the environment are not well understood. The microbial strains and consortia must be improved to increase the hydrogen production rate and system durability and to decrease the need for external power. In addition, methanogen growth must be controlled.

In laboratory tests, the primary feedstock for this technology has been acetic acid, although other organics have been demonstrated, such as glucose and even municipal waste. In general, yields and rates have been lower when using the more complex and lower-cost feedstocks. Methods must be developed to use low-cost feedstocks available in large supplies. In theory, acetic acid and other organic compounds could be obtained from the waste product of the dark fermentative hydrogen production, solving the feedstock problem for microbial electrolysis and the waste problem for the fermentative process.

Materials similar to those used in conventional PEM low-temperature water electrolysis are used in MECs. Current research is addressing lower-cost and durable alternatives to platinum as the catalyst of choice on the cathode.¹⁶⁷ Electrode materials range from carbon cloths and papers to graphite rods, plates, brushes and granules.¹⁶⁸ Materials with improved durability, greater strength, and lower costs are needed for practical scale units. In addition, electrodes with high surface areas are required for high reaction rates.

MEC reactors for practical applications will be scaled up from the current laboratory-scale devices in use.¹⁶⁹ The scaled-up reactors will need to offer performance similar to or surpassing that of the current lab-scale reactors while minimizing BOP, maintenance, and cost. The lab-scale reactors have shown high molar yields (2-4 moles H₂/mole acetic acid, which is 50-99% of the theoretical molar yield), but the rate at which the hydrogen is produced needs to be increased substantially. Methods to monitor and control the microbes and conditions must also be considered.

Unlike fermentation technologies, MECs have not yet been scaled up for industrial use, and further research is needed to increase the size of MECs while maintaining the performance seen at the lab scale.¹⁷⁰ In addition, the feasibility of using non-grid sources for energy input, either by using part of the hydrogen gas produced in a conventional fuel cell or by capturing waste energy, should be explored to make the process sustainable.

Combined System

In a likely combined system, a hydrogen fermentation reactor would be supplied with biomass, which would be broken down to hydrogen, as well as organic acids and other organic waste products that are excreted into the fermentation effluent. This effluent could then be used as the feedstock for an MEC system. In the longer term, biomass generated by photobiological hydrogen production (see Chapter 7) may be used by the fermentation system, and/or the effluent of the fermentation system may be used as a

¹⁶⁶ B. E. Logan, *Microbial Fuel Cells* (New York: John Wiley & Sons, 2008); B. E. Logan, "Scaling up microbial fuel cells and other bioelectrochemical systems," *Appl. Microbiol. Biotechnol.* 85 (2010): 1665–1671.

¹⁶⁷ Ibid.

¹⁶⁸ Ibid.

¹⁶⁹ Ibid.

¹⁷⁰ Ibid.

nutrient source for photobiological cultures.¹⁷¹ The downstream MEC system’s ability to utilize the fermentation effluent must be characterized and optimized, and the system design must consider the balance of the fermentation and MEC processes. Potential hydrogen production improvements will need to be balanced with potential negative impacts of the added complexity due to combining the systems.

Operations and Maintenance

O&M costs for biological hydrogen production must be comparable to those for other production techniques. In addition to issues common to all hydrogen production systems, biomass feedstock pre-conditioning, co-culture balance, inter-stage feed monitoring and conditioning, and waste processing must be considered. Hydrogen separation and purification systems must be developed to deal with the likely contaminants, such as water, volatile organics, and other gases, including carbon dioxide.

8.3 Strategy to Overcome Barriers and Achieve Technical Targets

Table 8.3 lists critical technology needs for biological hydrogen production. Discussion of these efforts follows the exhibit. Note that a single R&D activity may address more than one barrier, and multiple R&D activities may be needed to address a single barrier.

Table 8.3. Fermentative and MEC Hydrogen Production — Critical Technology Needs

Optimize Microorganism Functionality	<ul style="list-style-type: none"> ➔ Identify and characterize microorganisms and consortium with hydrogen production activity ➔ Identify conditions that optimize hydrogen production ➔ Develop or engineer strains and consortia with improved feedstock utilization, hydrogen production rates and yields, and reduced by-products ➔ Integrate the optimal functionality of the microorganisms into single organism or consortium
Reduce Feedstock Costs	<ul style="list-style-type: none"> ➔ Identify low-cost feedstocks that can be efficiently converted to hydrogen (for example, through R&D funded by the DOE Bioenergy Technologies Office) ➔ Develop microbial strains or consortia that can flexibly and efficiently utilize low-cost feedstocks
Address Materials Needs	<ul style="list-style-type: none"> ➔ Identify or develop low-cost, durable, high-efficiency MEC materials
Reduce Capital Costs	<ul style="list-style-type: none"> ➔ Identify or develop robust, low-cost microorganisms and consortia ➔ Reduce materials and component costs ➔ Reduce manufacturing and installation costs
Technoeconomic Analysis	<ul style="list-style-type: none"> ➔ Develop detailed technoeconomic models of prospective reactors based on promising microbial systems and reactor designs under development to guide R&D efforts toward meeting H₂ cost threshold

Addressing all of the barriers to meet commercialization cost targets for fermentative and MEC hydrogen production will require simultaneous R&D efforts in several areas, along with efforts to develop policy, standards, and delivery infrastructure technology. Although these efforts are taking place concurrently, the impact of each effort on the entire hydrogen production system must be kept in mind and integrated into systems optimization efforts.

¹⁷¹ P. C. Maness, “Fermentation and Electrohydrogenic Approaches to Hydrogen Production” (2012 Annual Merit Review Presentation, May 16, 2012), http://www.hydrogen.energy.gov/pdfs/review12/pd038_maness_2012_o.pdf; M. D. Redwood, M. Paterson-Beedle, and L. E. Macaskie, “Integrating dark and light biohydrogen production strategies: towards the hydrogen economy,” *Reviews in Environmental Science and Bio/Technology* 8, no. 2 (2009): 149–185.

In the near term, developing microorganisms and conditions with increased hydrogen production rates and yields is a high priority, especially using economical feedstocks. For MECs, low-cost, durable, high-efficiency materials are a priority, as are system designs that allow scaled-up reactors with production rates and yields similar to bench-scale systems. In the longer term, large-scale system designs must be developed that consider reductions in O&M and capital costs.

Appendix A: Acronyms and Initialisms

%	Percent
~	Approximately
<	Less Than
>	Greater Than
≥	Greater Than or Equal To
°C	Degrees Celsius
AC	Alternating Current
AHJ	Authorities Having Jurisdiction
APR	Aqueous Phase Reforming
ASTM	American Society for Testing and Materials (former)
ATP	Adenosine-5'-Triphosphate
ATR	Autothermal Reforming
BOP	Balance of Plant
Btu	British Thermal Unit(s)
C/N	Carbon/Nitrogen (ratio)
CCUS	Carbon Capture, Utilization and Storage
CG	Crude Glycerol
cm	Centimeter(s)
CO	Carbon Monoxide
CSP	Concentrated Solar Power
CTE	Coefficient of Thermal Expansion
DC	Direct Current
DFMA	Design for Manufacture and Assembly
DNGR	Distributed Natural Gas Reforming
DOE	U.S. Department of Energy
DOT	U.S. Department of Transportation
DRIVE	Driving Research and Innovation for Vehicle efficiency and Energy sustainability
E	Ethanol
EERE	Office of Energy Efficiency and Renewable Energy
EG	Ethylene Glycol
eV	Electron Volt
FCEV	Fuel Cell Electric Vehicle
FCT	Fuel Cells Technologies
FE	Office of Fossil Energy
FHL	Formate Hydrogen Lyase
g	Gram(s)
gge	Gasoline Gallon Equivalent
GHG	Greenhouse Gas
HPTT	Hydrogen Production Technical Team
HRT	Hydraulic Retention Time
Hz	Hertz
ICE	Internal Combustion Engine
IPPD	Integrated Product and Process Design
kg	Kilogram(s)
kΩ	Kiloohm(s)
lb	Pound(s)
LHV	Lower Heating Value
m	Meter(s)
MEA	Membrane Electrode Assembly
MEC	Microbial Electrolysis Cell
microS	Microsiemen(s)
MJ	Megajoule
MMBtu	Million Metric British Thermal Units

Hydrogen Production Technical Team Roadmap

MYRD&D	Multi-Year Research, Development and Deployment Plan (FCT Program)
MΩ	Megaohm(s)
NADH	Reduced form of nicotinamide adenine dinucleotide
NE	Office of Nuclear Energy
NHI	Nuclear Hydrogen Initiative
nm	Nanometer(s)
NREL	National Renewable Energy Laboratory
O&M	Operation and Maintenance
ORNL	Oak Ridge National Laboratory
P/R	Photosynthesis/Respiration (ratio)
PEC	Photoelectrochemical
PEM	Proton Exchange Membrane
PG	Propylene Glycol
PNS	Purple Non-Sulfur Bacteria
POX	Partial Oxidation
ppb	Parts per Billion
psi	Pounds per Square Inch
psig	Pound-Force per Square Inch Gauge
PV	Photovoltaic(s)
QA	Quality Assurance
QC	Quality Control
R&D	Research and Development
SC	Office of Science
SMR	Steam Methane Reformer
SNL	Sandia National Laboratories
STCH	Solar Thermochemical Hydrogen
STH	Solar-to-Hydrogen
USCAR	U.S. Council for Automotive Research
V	Volt(s)
VOC	Volatile Organic Compound
WGS	Water-gas-shift
×	Times (multiple)