



# Oahu Wind Integration and Transmission Study (OWITS)

## Hawaiian Islands Transmission Interconnection Project

Dennis Woodford  
*Electranix Corporation*  
*Winnipeg, Manitoba Canada*

NREL is a national laboratory of the U.S. Department of Energy, Office of Energy Efficiency & Renewable Energy, operated by the Alliance for Sustainable Energy, LLC.

**Subcontract Report**  
NREL/SR-5500-50411  
February 2011

Contract No. DE-AC36-08GO28308

# Oahu Wind Integration and Transmission Study (OWITS)

## Hawaiian Islands Transmission Interconnection Project

Dennis Woodford  
*Electranix Corporation*  
*Winnipeg, Manitoba Canada*

NREL Technical Monitor: David Corbus  
Prepared under Subcontract No. LAM-9-99436-01

**NREL is a national laboratory of the U.S. Department of Energy, Office of Energy Efficiency & Renewable Energy, operated by the Alliance for Sustainable Energy, LLC.**

**This publication was reproduced from the best available copy  
submitted by the subcontractor and received no editorial review at NREL.**

### **NOTICE**

This report was prepared as an account of work sponsored by an agency of the United States government. Neither the United States government nor any agency thereof, nor any of their employees, makes any warranty, express or implied, or assumes any legal liability or responsibility for the accuracy, completeness, or usefulness of any information, apparatus, product, or process disclosed, or represents that its use would not infringe privately owned rights. Reference herein to any specific commercial product, process, or service by trade name, trademark, manufacturer, or otherwise does not necessarily constitute or imply its endorsement, recommendation, or favoring by the United States government or any agency thereof. The views and opinions of authors expressed herein do not necessarily state or reflect those of the United States government or any agency thereof.

Available electronically at <http://www.osti.gov/bridge>

Available for a processing fee to U.S. Department of Energy  
and its contractors, in paper, from:

U.S. Department of Energy  
Office of Scientific and Technical Information

P.O. Box 62  
Oak Ridge, TN 37831-0062  
phone: 865.576.8401  
fax: 865.576.5728  
email: <mailto:reports@adonis.osti.gov>

Available for sale to the public, in paper, from:

U.S. Department of Commerce  
National Technical Information Service  
5285 Port Royal Road  
Springfield, VA 22161  
phone: 800.553.6847  
fax: 703.605.6900  
email: [orders@ntis.fedworld.gov](mailto:orders@ntis.fedworld.gov)  
online ordering: <http://www.ntis.gov/help/ordermethods.aspx>

Cover Photos: (left to right) PIX 16416, PIX 17423, PIX 16560, PIX 17613, PIX 17436, PIX 17721



Printed on paper containing at least 50% wastepaper, including 10% post consumer waste.

## Executive Summary

In October 2008, the State of Hawaii and the Hawaiian Electric Companies entered into the Hawaii Clean Energy Agreement to move Hawaii off of its dependence on imported fossil fuels for electricity and transportation. The U.S. Department of Energy contracted R.W. Beck in 2008 to evaluate interconnection of the transmission systems of the islands of Lanai, Molokai and Maui with Oahu. Phase I of this independent review included an initial evaluation of the technical configuration and capital costs of establishing an undersea cable system and examining impacts to the existing electric transmission systems as a result of interconnecting the islands. To move forward from the foundational work of the R.W. Beck report [1] and in support of the Hawaiian Clean Energy Agreement, the Department of Energy through the National Renewable Energy Laboratory contracted Electronix Corporation to study the undersea cable system necessary to transmit 400 MW of wind energy from the islands of Lanai and/or Molokai to Oahu (Stage 1) and the future installation of a 200-MW capacity cable system to interconnect the island of Maui (Stage 2).

The study effort included a technical feasibility assessment and budgetary cost estimate of the undersea transmission interconnect options. Inputs from the suppliers of undersea power cables and direct current (DC) converter station has been provided. Six DC cable options and one AC cable option were selected from 18 alternative configurations were developed by building on the R.W. Beck study [1]. Only one of the selected options included undersea cable transmission between Lanai and Molokai whereas all the alternatives from this previous study included undersea cable transmission between the two islands. The economic justification for undersea cable transmission between Lanai and Molokai could not easily be established, so the feed to Oahu from these islands was radial only.

The AC option was only considered viable if three core XLPE cable can be applied, but which is limited by the depth to which it can be laid because of its weight. Consequently it is precluded for feeding into Oahu. However, it could be used to interconnect Molokai and Lanai and even to Maui, and which was investigated for one option. For long AC undersea cables, the three core XLPE cable is the most viable configuration since having the three phase conductors as close together as possible results in significant cancellation of the magnetic field generated by the phase currents. Eddy currents and other induced currents in the shield and armor conductors of the cable are minimized allowing low induced cable

losses. Alternate use of three separate single core cables will result in higher losses in the shields and armors since there is no cancellation of the magnetic field generated by the phase currents unless the three cables are lashed and laid together.

The technology for the six selected DC options is voltage sourced converters (VSC). VSC can create a stable AC supply for wind turbine generators to connect into. They also offer a significant buffer to AC system faults at one end adversely impacting the AC system at the other end. The wind turbine generators on Molokai and Lanai will not be affected significantly by severe AC system faults on Oahu.

With a suitable control strategy for the VSC transmission, it will be possible to maintain a steady AC voltage and frequency for the sending end wind farms. This means that a direct and conventional interconnection to the small local load on Molokai or Lanai may be possible. It is only when the DC cable transmission is completely taken out of service that the interconnection to local load would have to be transfer tripped.

The capital costs for the six selected DC cable transmission options are assembled from the responses of the cable and equipment suppliers. The stated accuracy of these costs is  $\pm 20\%$ , and so the estimated values are the lowest provided by the suppliers plus 20%. Case A1-2(a) has a 200-MW DC connection between Lanai and Molokai and Case A1-2(b) has a 200-MW AC connection between Molokai and Lanai, which is slightly lower cost. Analysis (Appendix A) indicates additional justification will be needed to consider a Molokai to Lanai interconnection for Stage 1 development.

An independent option was proposed by one of the equipment suppliers whose significant benefit is the termination of the Stage 2 transmission from Maui at Lanai or Molokai instead of at Oahu as in the selected options in Table 1. Capital costs are therefore lower because less undersea cable is required, but suffers the disadvantage that power scheduled to Oahu from Maui would only be at the level possible when the wind power being generated on Lanai (and/or Molokai) is below full rating. Power schedules from Oahu to Maui on the other hand would not be restricted below the capacity limits of the converters and undersea cable transmission since any wind power being generated on Lanai and/or Molokai would be displaced accordingly.

Table 1: Budgetary capital Costs in 2009 millions of dollars as provided by suppliers of DC cable and DC converter equipment for the DC Options.

Option	C3-2	A3-2	A1-2		B3-2	C1-2	B1-2
Description	400 MW Koolau to Molokai	200 MW Molokai to Koolau, 200 MW Molokai to Iwilei	200 MW Molokai to Koolau, 200 MW Lanai to Iwilei, 200MW Lanai to Molokai		400 MW Molokai to Iwilei	200 MW Molokai to Koolau, 200 MW Lanai to Koolau	200 MW Molokai to Iwilei, 200 MW Lanai to Iwilei
			(a)	(b)			
Stations \$M	234	288	414	342	234	288	288
Cables \$M	154	180	367	424	221	216	245
Total Stage 1 Price \$M	388	468	781	766	455	504	533
Stage 2 Maui to Oahu (Approx)							
Converter Stations \$M	144	144	117	117	144	144	144
DC Cables \$M	420	420	192	192	283	272	272
Total Stage 2 Price \$M	564	564	309	309	427	416	416
Total Stages 1 & 2 \$M	951	1,032	1,090	1,077	882	920	949

The level of power schedules into or out of the HECO system on Oahu are restrained to the maximum single contingency outage possible, which for this study is 200 MW [2]. Rating the converters and cables above this level is certainly possible and perhaps desirable but requires further investigation.

From a technical perspective, the VSC cable transmission applied to these DC Options is completely viable with little risk of significant problems that would impede its use. The technology is being used to other similar projects of similar rating such as the BorWin Alpha 400-MW offshore wind farm in the North Sea<sup>1</sup>.

<sup>1</sup> The BorWin Alpha 400-MW project in the North Sea feeds offshore wind energy into Germany. This includes 125 km of undersea cables and 75 km of underground cable at  $\pm 150$  kV using ABB's HVDC Light technology. The platform AC voltage is transformed to 170 kV from the 36-kV AC collector system cables from the wind turbine generators. It feeds into the onshore substation at Diele at 400-kV AC. It was commissioned late in 2009.

## **Acknowledgements**

Appreciation is expressed for the support of Dave Corbus of NREL along with the team who met regularly to provide suggestions and directions. This includes Leon Roose, Marc Matsuura, Dora Nakafuji, Dave Burlingame, Dean Arakawa and Matt Schuerger.

Appreciation is also expressed for the support from Josh Strickler of the Department of Business, Economic Development and Tourism and Sandy Shor of the School of Ocean and Earth Science and Technology of who facilitated and provided the seabed data for the cable costing.

# Table of Contents

<b>EXECUTIVE SUMMARY .....</b>	<b>- 1 -</b>
<i>Acknowledgements .....</i>	<i>- 4 -</i>
<b>TABLE OF CONTENTS .....</b>	<b>- 6 -</b>
<b>INTRODUCTION .....</b>	<b>- 8 -</b>
<b>UNDERSEA CABLE OPTIONS.....</b>	<b>- 8 -</b>
TECHNICAL OPTIONS FOR AC AND DC CABLES .....	- 8 -
SELECTED HVDC OPTIONS .....	- 10 -
AC CABLE OPTION .....	- 15 -
ENVIRONMENTAL CONSIDERATIONS .....	- 17 -
RELIABILITY CONSIDERATIONS .....	- 17 -
LOSS CONSIDERATIONS .....	- 18 -
FUTURE CONNECTION TO MAUI .....	- 18 -
<b>CAPITAL COSTS ASSESSMENT.....</b>	<b>- 19 -</b>
ACCURACY OF COSTS PROVIDED.....	- 19 -
RANGE OF COSTS FOR TERMINATING SUBSTATIONS.....	- 19 -
COSTS FOR DC CONVERTER STATION OPTIONS.....	- 20 -
CAPITAL COST EVALUATION OF CABLE OPTIONS.....	- 21 -
CONSIDERATION FOR 400 MW WIND GENERATION ON LANAI.....	- 22 -
IMPACT OF LOSSES .....	- 23 -
IMPACT OF RELIABILITY .....	- 24 -
RISK .....	- 24 -
LIFE CYCLE COSTS .....	- 25 -
INDEPENDENT OPTION .....	- 27 -
<b>TECHNICAL STUDY .....</b>	<b>- 30 -</b>
OBJECTIVES .....	- 31 -
STUDY CONSIDERATIONS .....	- 31 -
VSC CONVERTER CONTROL STRATEGY .....	- 31 -
MOST SEVERE SINGLE CONTINGENCY DISTURBANCE .....	- 33 -
IMPACT OF FAULTS ON OAHU ON THE WIND TURBINE GENERATORS .....	- 34 -
IMPACT OF AC FAULTS ON MOLOKAI OR LANAI ON THE HECO GRID ON OAHU .....	- 34 -
<b>CONNECTION TO LOCAL LOAD ON MOLOKAI OR LANAI.....</b>	<b>- 35 -</b>
<b>CONCLUSIONS.....</b>	<b>- 36 -</b>
<b>REFERENCES .....</b>	<b>- 37 -</b>
<b>LIST OF APPENDICES.....</b>	<b>- 38 -</b>
APPENDIX A: SELECTION OF PREFERRED OPTIONS FOR THE INTER-ISLAND TRANSMISSION.....	- 38 -
APPENDIX B: EVALUATION OF SVC REQUIREMENT FOR INTER-ISLAND AC CABLE OPTION.....	- 38 -
APPENDIX C: SIMULATION STUDIES FOR INTER-ISLAND DC CABLE OPTIONS .....	- 38 -
APPENDIX D: REQUEST FOR INFORMATION FROM DC CONVERTER AND CABLE MANUFACTURERS .....	- 38 -
<b>APPENDIX A.....</b>	<b>- 39 -</b>
SELECTION OF PREFERRED OPTIONS FOR THE INTER-ISLAND TRANSMISSION.....	- 39 -
<i>Introduction.....</i>	<i>- 39 -</i>
<i>Impact of Losses.....</i>	<i>- 40 -</i>
<i>Capital Cost Summary Including Losses .....</i>	<i>- 42 -</i>
<i>Description of Preferred Options.....</i>	<i>- 43 -</i>
<i>Impact of Reliability.....</i>	<i>- 47 -</i>
<i>Possibility for Spare Cable .....</i>	<i>- 49 -</i>
<i>Cable Connection Between Lanai and Molokai.....</i>	<i>- 50 -</i>
<i>Summary .....</i>	<i>- 50 -</i>



<b>APPENDIX B</b> .....	<b>- 51 -</b>
EVALUATION OF SVC REQUIREMENT FOR INTER-ISLAND AC CABLE OPTION .....	- 51 -
<i>Introduction</i> .....	- 51 -
<i>Modeling</i> .....	- 52 -
<i>Overvoltage Control</i> .....	- 53 -
<i>Conclusions</i> .....	- 57 -
<b>APPENDIX C</b> .....	<b>- 58 -</b>
SIMULATION STUDIES FOR INTER-ISLAND DC CABLE OPTIONS .....	- 58 -
<i>Introduction</i> .....	- 58 -
<b>APPENDIX D</b> .....	<b>- 77 -</b>
<b>PRICING</b> .....	<b>- 83 -</b>
TECHNICAL DATA REQUESTS .....	- 89 -
<b>PRICING</b> .....	<b>- 109 -</b>

## **Introduction**

High voltage direct current transmission is very much an evolving technology with the application of voltage sourced converters (VSC) to cable systems and now to overhead transmission. ABB were the pioneers of this technology in the 1990s as it is applied to commercial power transmission. Siemens have now entered the market and Areva will be able to offer VSC transmission in 2010.

Using previous studies [1], [2] as a reference, eighteen new transmission options were developed from which 6 DC cable options and 1 AC cable option were developed in Appendix A for further investigation and costing for electrically interconnecting the Hawaiian Islands of Molokai, Lanai and Maui to Oahu. Each supplier of DC converter equipment was invited to cost out the converter stations. Seabed data was provided by the University of Hawaii School of Ocean and Earth Science and Technology to enable the manufacturers of undersea power cables to realistically estimate the costs of laying and burying cable (Appendix D).

The capital costs provided by the suppliers of power cable and converter station equipment are summarized and a technical evaluation of the interconnection project is made.

## **Undersea Cable Options**

### ***Technical Options for AC and DC Cables***

The preferred options for undersea cable power transmission to Oahu from Molokai, Lanai and Maui were selected based on the options developed in the R.W. Beck report [1] followed by an additional study that examined the impact of capital costs, losses and reliability. Eighteen inter-island AC and DC transmission options were formulated and analyzed for selection of preferred cases (Appendix A) using best available costs for cables and converters<sup>2</sup>. Six high-voltage direct current (HVDC) and one alternating current (AC) power cable transmission options were selected for further assessment. The most significant difference between these new options and the earlier ones developed [1] is that undersea

---

<sup>2</sup> The Appendix A cost assessments did not use the latest cost information from the equipment suppliers as they had not been requested at this stage in the study. Instead best available costs were used to select lowest cost options for this initial assessment of 18 cable transmission alternatives.

cable transmission between Molokai and Lanai is excluded because it was difficult to economically justify. Nevertheless one of the new preferred options did include undersea cable transmission between Molokai to Lanai. Each preferred option is divided into two stages.

Stage 1: A total of 400 MW terminating on Oahu, originating on Molokai and/or Lanai. This would be the stage that would be constructed first.

Stage 2: 200-MW capacity cable connecting Maui to the transmission system constructed in Stage 1. This would be constructed at a later time.

For the purpose of this study and in understanding the HVDC options under consideration, two configurations are considered for the converters. Each configuration limits the loss of capacity due to a single point of failure to 200 MW which was assumed to apply at all landing sites studied on Oahu. This was a requirement since HECO normally operates with 180 MW of spinning reserve and an instantaneous loss of 400 MW due to a single point of failure would not be acceptable. These are:

1. The 200-MW symmetrical monopole. This is shown in diagram form in Figure 1. It consists of a single HVDC converter rated at  $\pm 150$  kV, and 200 MW and two undersea cables. If any one component is faulted, the power transfer is lost.

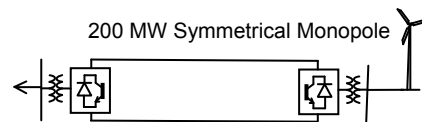

Figure 1: HVDC Symmetrical monopole

2. The 400-MW bipole. This is shown in diagram form Figure 2. It consists of two identical and independent 200 MW monopoles, one at +150 kV and the other at -150 kV, with three undersea cables, of which one is grounded at one end that serves as a metallic return path when one pole fails. The DC current capacity of the metallic return cable is rated to the same level of the pole cables. However, the voltage rating can be less.

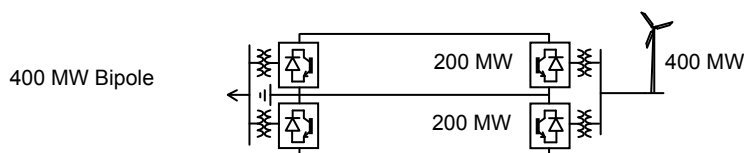

Figure 2: HVDC bipole

The HVDC converters are voltage sourced converters (VSC). This is the converter technology ABB have used for the Cross Sound transmission between Long Island and Connecticut (HVDC Light) and which Siemens have applied for the TransBay project between Pittsburg, California and San Francisco (HVDC Plus). VSC converters are expected to have a life span comparable to conventional thyristor-based HVDC converters of 40 years.

An advantage in the VSC technology is it allows use of solid insulation undersea cables. They are comparatively lower cost than the mass impregnated cables that have been traditionally applied for HVDC undersea power transmission, largely for the reason that the solid insulated cables are lighter in weight than mass impregnated cables. The suppliers of cables were not restrained as to what type of cable to provide when budget costs were requested for this application. As a consequence, they only proposed solid insulated cables suggesting that they would be the lower cost cables to supply. VSC converters can support and even provide an ac voltage supply, which is important for connecting wind farms on Molokai and Lanai. Six VSC projects with solid insulated undersea cables are now in service throughout the world, with one project (CrossSound) in service in the U.S.

For the HVDC bipole configuration of Figure 2, there is a possibility of using pole cables with an imbedded neutral. If each high voltage DC cable has an imbedded neutral, then on loss of one, the remaining pole cable could continue to support the operation of the healthy pole using its imbedded neutral as a metallic return conductor. In this way the third metallic return conductor as shown in Figure 2 would not be required as the imbedded neutral conductor would serve as the metallic return path. Loss of one cable in a bipolar configuration would allow full operation of the other pole through the remaining cable. The cost saving in requiring only two cables with imbedded neutral conductors instead of three conventional coaxial cables may be offset by the more conductive material needed in each cable with imbedded neutrals and the consequential greater weight resulting in limits on seabed depth to which it could be laid.

### ***Selected HVDC Options***

With these converter configurations, the selected options for undersea cables are summarized visually as follows. More details are available in Appendix A with the assumption that the

Stage 2 interconnection is rated to 200 MW, and traverses the full distance from Maui to Oahu.

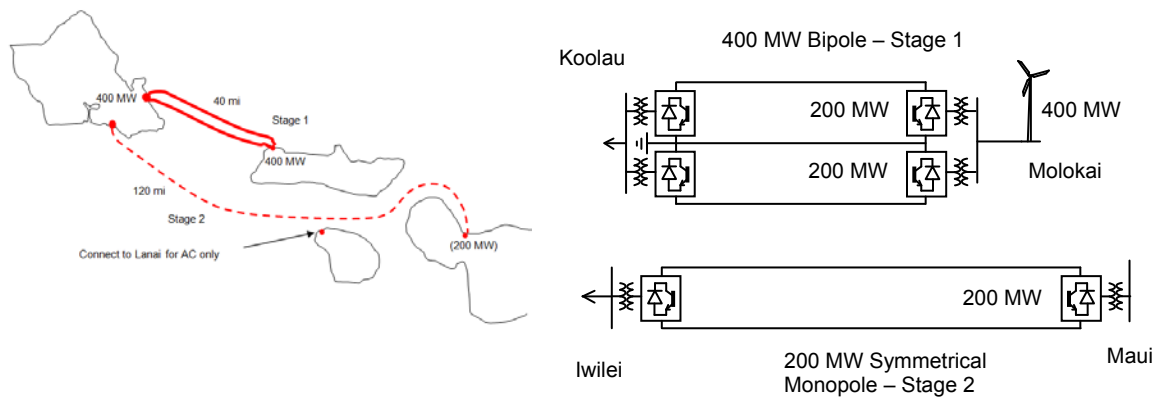

Figure 3: HVDC Option C3-2

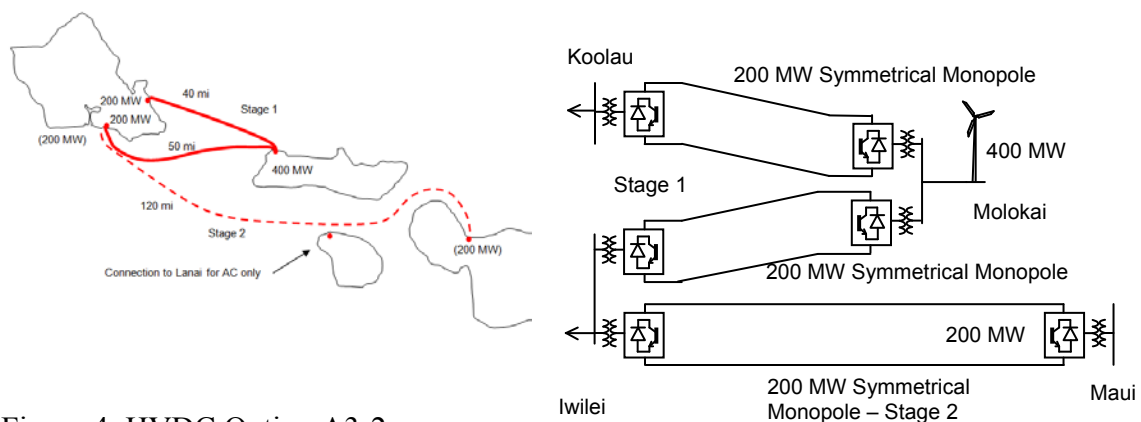
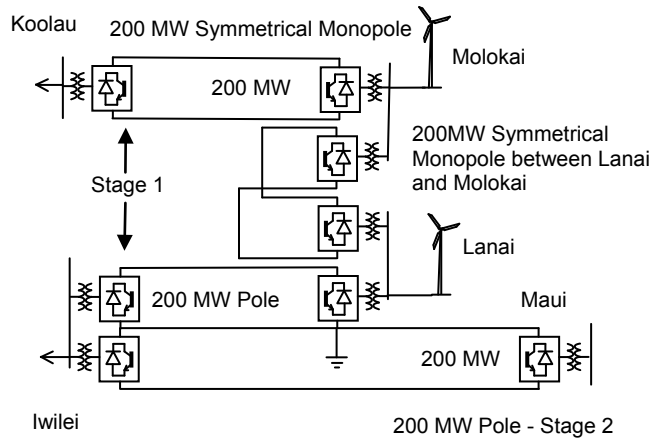
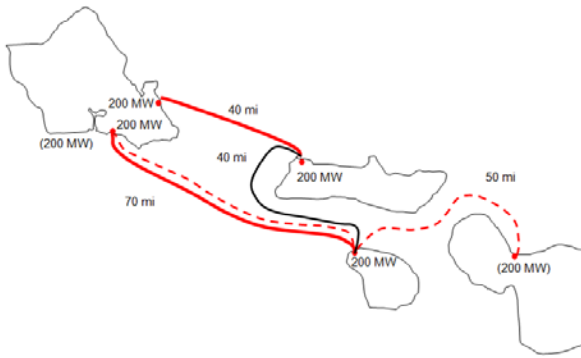
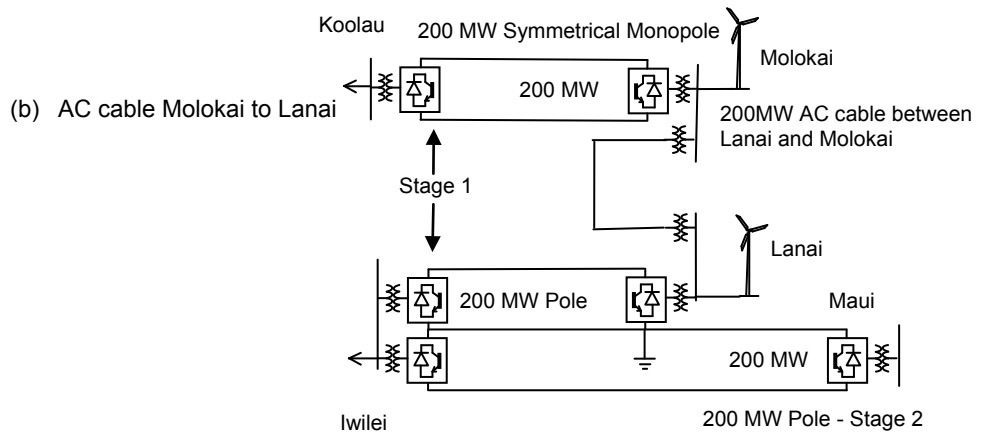

Figure 4: HVDC Option A3-2

Option A1-2 shown in Figure 5 includes a cable interconnection between the islands of Molokai and Lanai. Two alternative cases are proposed, the DC alternative and an AC alternative. The DC alternative is a  $\pm 150$ -kV, 200-MW symmetrical bipole and the AC alternative is with a 230-kV, three-core XLPE cable. Although the AC interconnection between Molokai and Lanai was not studied specifically, the general results and conclusions in Appendix B apply.



(b) DC cable Molokai to Lanai



(b) AC cable Molokai to Lanai

Figure 5: HVDC Option A1-2 (a) with DC cable Molokai to Lanai and (b) with AC cable

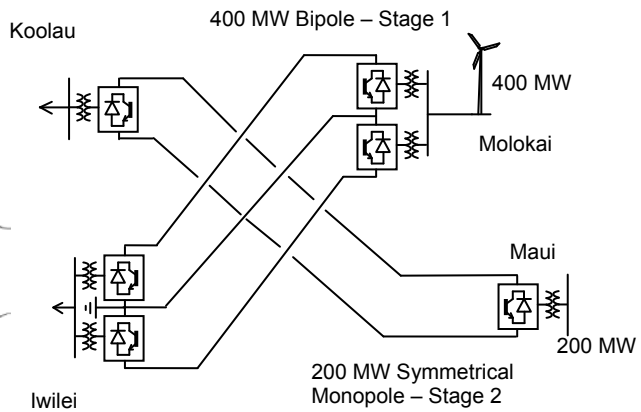
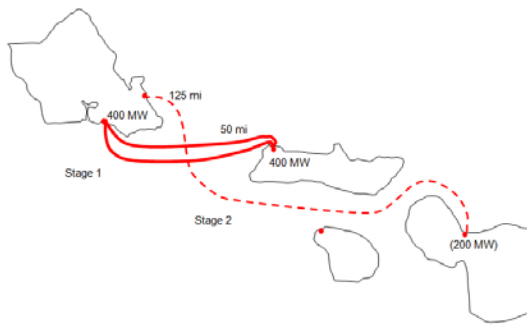

Figure 6: HVDC Option B3-2

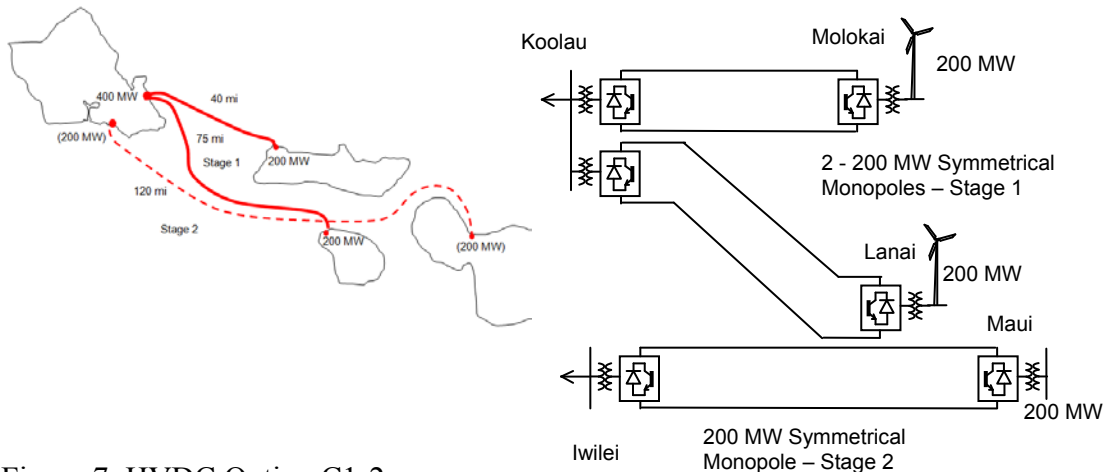

Figure 7: HVDC Option C1-2

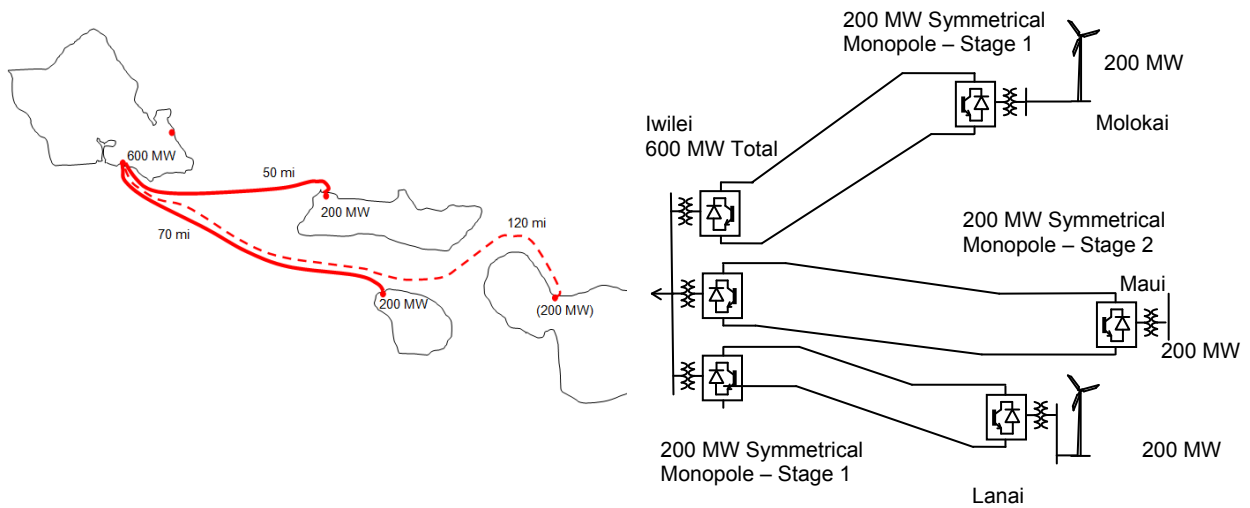

Figure 8: HVDC Option B1-2

All cables that cross Penguin Bank and the Humpback whale sanctuary (Appendix D) will be buried in the seabed.

Impact of Stage 1 on the later installation of Stage 2 is in being able to anticipate where the Stage 2 converter will be eventually located on Oahu. As the Stage 1 converters are located, will or should space be left for the future installation of a Stage 2 converter? If the installation date of Stage 2 is known with a fair degree of certainty, then the location of its Oahu converter can be sited in coordination with the Stage 1 converters. This coordination will include the cables associated with each Stage.

Option A1-2 shown in Figure 5 integrates an HVDC bipole between the two stages. This concept will be most effective when timing and siting for the converters and cables of each stage are known. Then the laying of undersea cable can be coordinated such as deciding whether to purchase and lay Stage 1 and 2 cables together or delay the purchase and laying of the Stage 2 cables. Option A1-2 takes advantage of extending one pole of a bipole to Maui. Such a configuration has been contemplated in previous projects but never applied. It is considered acceptable since each pole must be independent to ensure outage or failure is contained to just a single pole. The controls of each pole including their synchronization would be completely independent. However, currents would flow in the neutral conductor.

The radial configuration of HVDC feeders to Oahu from Molokai and Lanai means that each feeder is independent of Stage 2, with the only exception being Option A1-2 as discussed.

A limitation on rating of cables and converters is the first contingency outage of 200 MW. If it is possible to increase this level in the known future, then it would be possible to correspondingly rate the undersea feeder cables to a higher level initially to take advantage of this increased first contingency outage level. Larger rated wind farms on Molokai and Lanai could be anticipated along with additional HVDC converter capacity. The decision to over-rate the cables and converters initially would be subject to study, knowing when and to what level the outages can be increased for N-1 survival.

It is recommended that Stage 1 cable and converter rating continue to be defined by the contingency outage of 200 MW unless it is known for certain that a higher level will be possible in the foreseeable future. In this case, the HVDC undersea cables could be initially rated to this higher level. The HVDC converters could be sized for uprating when needed.

It is also recommended that Stage 2 be independently developed and constructed if rated to 200 MW. Where possible, converter station and cable landing space on Oahu should be identified and preserved. However, there is a possibility the Stage 2 cable transmission is terminated on Lanai or Molokai rather than on Oahu if rated less than 200 MW, and this option is considered further in this report.



### AC Cable Option

Figure 9 presents a 230-kV AC cable option A1-1. The undersea distances involved are relatively long for AC undersea cable transmission but are quite doable if 3 core 230-kV cables can be used. The use of solid insulated cables in the form of Cross-linked Polyethylene (XLPE) is beneficial in this respect. Each set of cables may be either a single cable with three cores imbedded together along with a fiber cable, or as three separate cables laid or lashed together. The cables of each of the separate phases need to be close together in order to minimize losses in the metallic shields due to magnetic coupling with the current in each phase conductor. However, there is difficulty in laying three such cables together if they cannot be unloaded from the one ship at the same time.

In response to a request for information to undersea cable suppliers, it was indicated that the use of a single AC cable with three imbedded cores although a lower cost than three separate single core cables, was not practical for the depths involved. The heavier weight prevents its laying to such depths. However, it is feasible to apply the AC three-core cable in the shallower depths between Molokai and Lanai as shown in Figure 5.

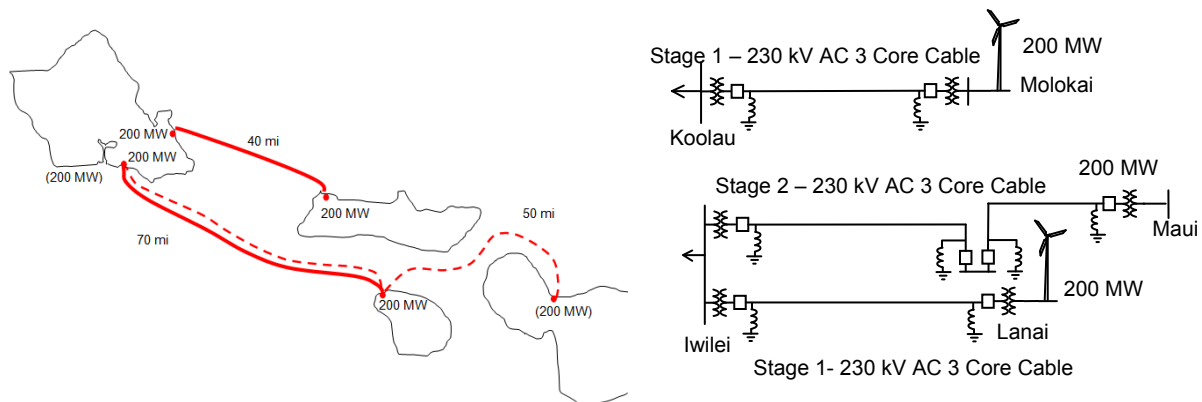

Figure 9: AC Option A1-1

If AC cables can operate and do so with minimum impact on the wind farms at the sending end and on the AC system of HECO on Oahu, they have to be 100% shunt compensated. AC cables have very high shunt capacitance that need to be fully counteracted at 60 Hz by fixed shunt reactor compensation. However, the AC cables have relatively low series impedance compared to overhead transmission lines of similar length and voltage (approximately 30% of

the series impedance of an equivalent overhead line). With reference to Figure 9, the electrical distance that the wind farm on Molokai is removed from Oahu with XLPE AC cables is equivalent to only 30% of the 40 miles (which is 12 miles) if connected through an equivalent 230-kV overhead transmission line. Similarly, the equivalent overhead line electrical distance from Lanai to Oahu is 21 miles instead of 70 miles, again because of the low series impedance of the undersea AC cables. As a consequence the wind farms at Molokai and Lanai connected to Oahu through AC cables would appear electrically close except that the impedance of the transformers at each end of the cable adds to the cable impedance.

Energizing such a long AC cable would be done from the Oahu end only. It would be energized with a special two circuit breaker arrangement together with a series pre-insertion resistor. The first circuit breaker closes the pre-insertion resistor to charge up the cable since it is resonantly tuned because of being 100% shunt compensated. When the cable has reached close to the operating voltage after a number of cycles, the second circuit breaker closes by-passing the resistor and bringing the cable on line such that the AC voltage on the HECO system is not transiently disrupted.

From studies undertaken for the AC cables, the following conclusions are made regarding compensation and overvoltage on the AC cable feeders for the wind farms. Only Stage 1 cable transmission is studied with one radial feeder to Koolau from Molokai and one radial feeder to Iwilei from Lanai.

1. Under normal operation, reactive power loading at the connection busbars is quite manageable when the AC cables are 100% shunt compensated. No additional facilities for reactive power are required at either end of the cables to compensate the variations in reactive power with variations in power flow through the cable. The normal reactive power requirements for a wind farm interconnection should apply at both Lanai and Molokai.
2. The AC cables can be energized virtually transient free with the pre-insertion resistance strategy applied, thereby alleviating the need to apply an SVC or STATCOM to smooth out voltage transients.

3. When the AC cables are connected to the network and in service, their resonant frequency approaches the second harmonic (120 Hz). When an ac fault is cleared near either end of the cable, local transformers will saturate. The resulting magnetizing currents into these transformers will contain a second harmonic current which can cause over-voltages on the cable with a second harmonic resonance. This issue will have to be addressed if AC cables are contemplated. Special filters or thyristor-switched metal oxide arresters are options to investigate if harmonic over-voltages are possible with the cables selected.
4. Of concern with the AC undersea cables is the resulting voltage when the cable opens up at its receiving end (Oahu end) following a bus fault on the interconnection bus or if it inadvertently trips out of service at Oahu. An overvoltage on the cable and on the wind farm AC network at the sending end will occur if the wind turbine generators stay connected at the sending end. The study on AC cable overvoltage is included in Appendix B.

### ***Environmental Considerations***

There are significant environmental issues that must be addressed for this project. A cost factor in laying cables is its burying in the seabed, an exercise that also has an environmental impact. The cable prices provided by the cable manufacturers reflects the burying of cables where needed based on the seabed information provided in the request for information. One cable manufacturer based cost for laying the cable on the assumption that the cable would be buried for depths less than 125 meters. When the cables are to be purchased, the depth requirement will need to be specified to ensure that its environmental impact is acceptable.

### ***Reliability Considerations***

The main components of cable transmission are subject to failure, so that when a failure does occur usually results in loss of delivered energy. It is not possible to predict future failure of equipment for the OWITS Project. All we can do in this respect is assign a failure rate and repair time to the equipment that meets our expectation for cable operation. Variations to the selected failure rates and repair times can be made to evaluate sensitivity of the energy delivery to cable transmission outage. However, the depth to which cables are buried in the seabed and the separation distance between them will impact the reliability of the cable system. The cable contractor can recommend suitable burial strategies to optimize cable

laying costs against improvements in expected reliability, but would do so after they have conducted a thorough seabed survey.

The loss of energy delivered (usually designated loss of load expectation or LOLE) for each of the preferred options is estimated in Appendix A. This analysis concluded that the cost of spare cables for all DC Options could not be justified from savings in replacement energy that was possible following cable failure.

The one converter station equipment supplier that has a significant number of VSC transmission systems in service so that a performance record is available, provided the following expected outage statistics that would apply to one 200-MW pole or monopole. Undersea cable outages are excluded from these values.

Forced Outage rate (FOR)	<5 outages/year
Forced Energy Unavailability (FEU)	<0.5%
Energy unavailability due to scheduled maintenance (SEU)	<1.0%

Forced outages in the converter stations are usually of a short duration and are usually due to control and protection issues and operator error.

### ***Loss Considerations***

The cost of losses for the DC and AC Cable options was determined in Appendix A. A capitalized value of the cost of losses was estimated for each Option and for addition to the capital costs of the cables and terminal stations. Variations in the capitalized cost of lost energy do not change the selection of preferred Cable options.

### ***Future Connection to Maui***

A Stage 2 interconnection from Maui to the transmission system constructed in Stage 1 is contemplated as a consideration for expansion capabilities of the Stage 1 configurations as indicated in Figures 3 to 9. Definition of the project and the installation date for Stage 2 is not known. The objective of evaluating these options is to determine potential benefits of constructing Stages 1 and 2 simultaneously.

## **Capital Costs Assessment**

Requests of information and costs were requested of the suppliers of VSC converter stations and undersea cables for the six DC options and the one AC option for the Oahu Wind Integration and Transmission Study. A copy of the documents requesting the information from the suppliers is included in Appendix D.

### ***Accuracy of Costs Provided***

The accuracy of the costs provided for the VSC converter stations were stated by the DC equipment suppliers in their responses as being  $\pm 20\%$  but the variation of costs between the three equipment suppliers was 1.5:1. The accuracy of capital costs provided for the supply and laying of the undersea cables were stated was also at  $\pm 20\%$ , but the variation of budget costs was 3:1. These variations in budget costs raise uncertainty to the values used. However, the lowest costs were provided by a supplier who has constructed operating VSC projects. Consequently, the budget costs used herein are expected to not be too far from reality. Detailed seabed information, metal prices and currency exchange rates will impact the final costs.

### ***Range of Costs for Terminating Substations***

The responses received for the DC Options are summarized in Table 1 were the costs for the Stage 1 development of the Inter-Island DC cable transmission options. Stage 2 costs from Maui to Oahu are included as derived from Stage 1 costs and are approximate at this stage. These costs are based on a 20% addition to the lowest cost provided in order to arrive at an estimate that is not underpriced and to allow for variations in seabed information, metal prices and currency exchange rates. The identities of the suppliers are excluded to maintain confidentiality.

Table 1: Capital Costs in 2009 millions of dollars as provided by suppliers of DC cable and DC converter equipment for the DC Options (with ac cable between Molokai and Lanai A1-2 (b)).

Option	C3-2	A3-2	A1-2		B3-2	C1-2	B1-2
Description	400 MW Koolau to Molokai	200 MW Molokai to Koolau, 200 MW Molokai to Iwilei	200 MW Molokai to Koolau, 200MW Lanai to Iwilei, 200 MW Lanai to Molokai		400 MW Molokai to Iwilei	200MW Molokai to Koolau, 200 MW Lanai to Koolau	200MW Molokai to Iwilei, 200 MW Lanai to Iwilei
			(a)	(b)			
Stations \$M	234	288	414	342	234	288	288
Cables \$M	154	180	367	424	221	216	245
Total Stage 1 Price \$M	388	468	781	766	455	504	533
Stage 2 Maui to Oahu (Approx)							
Converter Stations \$M	144	144	117	117	144	144	144
DC Cables \$M	420	420	192	192	283	272	272
Total Stage 2 Price \$M	564	564	309	309	427	416	416
Total Stages 1 & 2 \$M	951	1,032	1,090	1,077	882	920	949

These prices are the value for engineering, procurement and construction (EPC). They exclude costs to the purchaser in terms of insurance, site preparation, connection costs to the grid or wind farm collector system, purchaser’s management and engineering costs and interest during construction.

The Stage 2 prices would be adjusted for escalation and present value that would depend on the number of years the installation would follow Stage 1.

### **Costs for DC Converter Station Options**

The prices received from the three major suppliers of DC converter stations are estimated into a useable value in Table 2. There is variation in prices received and the values estimated for inclusion in the summary are included in Table 2. The estimated cost applied is 20% higher than the lowest price submitted.

Table 2: Prices for DC converters, single end

Type of DC Converter Station	Estimated Price \$M
200-MW symmetrical monopole DC converter station	72
400-MW bipole DC converter station	117
200-MW pole of a 400-MW DC converter station built first	63
200-MW pole of a 400-MW DC converter station built second at a different time	54

### ***Capital Cost Evaluation of Cable Options***

The prices for DC cable options are summarized in Table 3. From these prices, the capital costs are assembled into Table 1. It was disclosed by several cable manufacturers that AC cable circuits as requested for AC Option A1-1 (Figure 9) were not practical and no pricing was provided. One stated that AC Option A1-1 is “deemed impractical for transmission due to distance, depth, losses, charging current, operational difficulties, cost, time for transport and cable laying. Depth would require spaced 3 x single-core cables for laying, three passes with cable laying vessel. More conductor area would be provided in armor due to increased current induction compared to three core cables.”

Another cable manufacturer responded that “the water depths between Lanai, Molokai and Oahu preclude using 3-core cables due to their greater weight. Single-core cables require greater conductor area in the cable armor to handle the higher induced currents. Cable charging current (of single core cables) would be in the order of 420 amps per 50 km of cable requiring greater conductor area for these longer cable distances. The installed cost for the longer, deep water AC cable crossing would be significantly higher. Furthermore, the remote wind plants would be exposed to system faults on Oahu leading to overall performance issues. Therefore, using AC submarine cables for these circuits is deemed impractical. Hence no budgetary estimates are provided for the AC cable option. On the other hand, use of 3-core AC cables for interconnecting Molokai with Lanai with the shallower water depths and shorter distance, especially if some overhead transmission could be used, is practical, economic, provides for greater resource diversity and operating flexibility.”

The prices for DC cables in Table 3 are basically for both a 400-MW bipole where 1200 mm<sup>2</sup> conductor was priced and for a 200-MW symmetrical monopole where a 500 mm<sup>2</sup> conductor was priced. (Note that in the technical studies for the bipole configuration, a 1600 mm<sup>2</sup> DC cable was applied. This difference will have minimal impact on the results of the technical

study since the conclusions on the technical performance will not change because of the cable conductor size). However, prices of the DC undersea cables will vary with conductor size and the cable suppliers selected the sizes to apply in their response to the price request. Again the estimated cost applied is 20% higher than the low price submitted.

Table 3: Prices for DC cables including burial and terminations as provided by suppliers of undersea cables

<b>DC Cable Configuration</b>	<b>Estimated Price \$M</b>
400-MW bipole: 3 cables 60 km, 2 at $\pm 150$ kV, 1,333 A, 1 at 1,333 A, 50 kV	154
400-MW bipole: 3 cables 87 km, 2 at $\pm 150$ kV, 1,333 A, 1 at 1,333 A, 50 kV	221
2 to 200-MW monopoles: 2 cables 60 km, 2 Cables 87 km, $\pm 150$ kV, 667 A	180
2 to 200-MW monopoles: 2 cables 60 km, 2 Cables 64 km, $\pm 150$ kV, 667 A 3 cables 126 km for 400-MW bipole operation	367
2 to 200-MW monopoles: 2 cables 60 km, $\pm 150$ kV and 667 A, 2 cables 120 km, 667 A	216
2 to 200MW monopoles: 2 cables 87 km at $\pm 150$ kV and 667 A, 2 cables 126 km, 667 A	245

The cases prepared and studied route undersea cable around Molokai outside the southern and western reef in preference to overhead transmission across Molokai. It is recognized that capital costs will be minimized with minimum undersea cable length. This option can be studied further if an overland route across Molokai is considered to be a viable alternative and it is acceptable to take the undersea cable through the reef to an on-shore location on the south side of Molokai.

### ***Consideration for 400 MW Wind Generation on Lanai***

The options selected for HVDC cables from Lanai and Molokai as presented in Figures 3 to 8 are based on the assessment reported in Appendix A. Options C3-2, A3-2 and B3-2 have 400 MW of wind generation only on Molokai and none on Lanai. These were selected simply because they were lowest cost resulting from Molokai being closer to the Oahu load than Lanai. 400 MW of wind generation on Lanai was evaluated in the option selection process reported in Appendix A as Options C2-2, A2-2 and B2-2. With the update from supplier's capital costs for undersea cables, the comparison between options with 400 MW of wind generation on Molokai and on Lanai for Stage 1 capital costs is presented in Table 4.



Table 4: Stage 1 Capital Costs in 2009 millions of dollars as provided by suppliers of DC cable and DC converter equipment for the DC Options that include 400 MW of wind generation on Lanai compared with on Molokai

Option	C3-2	C2-2	A3-2	A2-2	B3-2	B2-2
Description	400 MW Molokai to Koolau	400 MW Lanai to Koolau,	200 MW Molokai to Koolau, 200 MW Molokai to Iwilei	200 MW Lanai to Koolau, 200 MW Lanai to Iwilei	400 MW Molokai to Iwilei	400 MW Lanai to Iwilei
Stations \$M	234	234	288	288	234	234
Cables \$M	154	318	180	303	221	303
Total Stage 1 Price \$M	388	552	468	591	455	537

### **Impact of Losses**

The cost of losses between Options was evaluated in Appendix A where the assumptions for their analysis are presented. One key assumption was that the cost of losses was assessed at 15c/kWhr for a load capacity factor on the cables derived from the wind energy sources at 35% and at 25c/kWhr for a load capacity factor of 25%.

The loss accumulation for the Stage 1 development of cable transmission from Lanai and Molokai is assumed over 20 years and the present value of these losses is capitalized to year 1. The discount rate is applied at 5% p.a<sup>3</sup>. The capitalized value of losses is then added to the capital cost of the Stage 1 option and is summarized in Table 5 for a 35% capacity factor and in Table 6 for a 25% capacity factor.

The assumptions of cost of make-up power for losses, 20 years for a present value analysis, 5% for discount rate and 25% and 35% for capacity factor offer a general indication of the impact of the cost of losses for comparison with capital expenditure. The values applied for these assumptions cannot be accurately predicted since they entail knowing the future. For example, 20 years for present value analysis might be too short, but the life of wind turbine generators is about 20 years, but the undersea cable may last over 40 years. In this case, 20 years for present value analysis is selected. Similarly, a discount rate of 5% is applied, but in this day and age the difference between escalation and interest may be quite different and change over time. If Stage 2 to Maui is developed, then capacity factor on the cables may

<sup>3</sup> Discount rate as applied here is approximately the difference between long term interest and escalation of costs.

increase above 35%. Therefore, the cost of losses, reliability and life cycle costs are represented in this study as an indication of their impact and not a definite measure.

### ***Impact of Reliability***

The main components of cable transmission are subject to failure, so that when a failure does occur it usually results in loss of delivered energy. It is not possible to predict future failure of equipment for the OWITS Project. All we can do in this respect is assign a failure rate and repair time to the equipment that meets our expectation for cable operation. Variations to the selected failure rates and repair times can be made to evaluate sensitivity of the loss of energy delivered due to cable transmission outage.

The basic unscheduled failure rates and repair times are listed in Table A-3 of Appendix A. They are indicative of what may be expected of the undersea cable performance. The loss of energy delivered (usually designated loss of load expectation or LOLE) for each of the preferred options is assembled into Tables 5 and 6. This LOLE energy is costed both at 15c/kwh (35% capacity factor) in Table 5 and at 25c/kwh (25% capacity factor) in Table 6 for a 20 year present value accumulation at a discount rate of 5% similar to the loss evaluation.

### ***Risk***

The reliability analysis undertaken in Appendix A and with results included in Tables 5 and 6 is operational risk equated into a cost for comparison purposes. The risk associated with implementing the equipment and relatively new technology of voltage sourced HVDC converters and solid insulated HVDC cables cannot be readily translated into comparative costs. The main assurances on implementation risk are:

1. Voltage sourced converters are a successful technology that can be used with low cost undersea cables.
2. The first application of applying voltage sourced converters for a dedicated radial HVDC feeder came into service as the BorWin Alpha project and was commissioned towards the end of 2009. This is a 400-MW offshore wind farm HVDC feeder in the North Sea where the sending end converter station is on a platform as shown in Figure 10. The assurance here is that the VSC converter can provide an adequate AC voltage for wind turbine generators to operate into. Conventional HVDC transmission technology cannot do this unless there is AC short circuit capacity provided by synchronous generators or condensers that will support AC voltage for both the wind turbine generators and the conventional HVDC converters. Voltage sourced converter

technology has become acceptable in the electric utility industry. Performance of the Cross Sound VSC Cable and VSC Converters (commissioned in 2002) indicate its performance to be within the normal range of operation of HVDC transmission.<sup>4</sup>



Figure 10: BorWin Alpha Project  
(Photos courtesy of ABB)

The greatest implementation risk in this project will be to have effective project management with the purchaser and with the supplier. Having technical expertise of the equipment supplier who can be committed to support the project is also key. This is a challenge for equipment suppliers who are spread thin with other large projects. If project management and high level technical support is inadequate, the project will suffer delays in installation and in achieving acceptable operational performance.

### ***Life Cycle Costs***

Life cycle cost considerations for HVDC substation and transmission components and equipment include all of the possible costs. Those costs include operation and maintenance (O & M), labor, spare parts, expected repairs, insurance and warranties that a piece of

---

<sup>4</sup> Report to 11<sup>th</sup> FACTS User's Group, October 22-24, 2008, Islandia, NY by CrossiSound Cable Company, LLC

equipment would normally be expected to encounter during its service life. Life cycle cost should also include some expected outage costs for planned and unplanned maintenance. Local and State annual taxes and grants can be included in the life cycle costs. The life cycle costs of a DC-cable transmission system and wind generation from Molokai or Lanai can also include operating costs saved on Oahu fossil fuel generators when displaced by renewable energy.

Excluding taxes and savings in operating costs due to use of wind generation compared to fossil fuel generators, a percentage of capital station cost at 1% pa is selected for basic operation and maintenance (O & M) and other operating charges over a 20-year life cycle for a present value (PV) assessment at a 5% discount rate. Operating costs due to losses and reliability in both the cables and the converter stations are discussed above and are separately included in Tables 5 and 6. The planned maintenance outage of 1 week per two years is included as part of the operating cost and assigned the same values for energy not delivered as for losses and reliability.

Table 5: 20 year present value cost of losses, impact of reliability and life cycle costs for the selected DC undersea cable Stage 1 transmission options for a 35% capacity factor.

<b>Option</b>	<b>C3-2</b>	<b>A3-2</b>	<b>A1-2</b>	<b>B3-2</b>	<b>C1-2</b>	<b>B1-2</b>
Description	400 MW Koolau to Molokai	200 MW Molokai to Koolau, 200 MW Molokai to Iwilei	200 MW Molokai to Koolau, 200 MW Lanai to Iwilei, 200 MW Lanai to Molokai	400 MW Molokai to Iwilei	200 MW Molokai to Koolau, 200 MW Lanai to Koolau	200 MW Molokai to Iwilei, 200 MW Lanai to Iwilei
Total Stage 1 Price \$M	388	468	781	455	504	533
PV Losses \$M	122	129	137	124	133	135
PV (LOLE) Reliability \$M	41	60	73	47	83	79
PV Life cycle costs \$M	40	42	59	40	59	59
Total PV Operating Costs \$M	203	231	269	211	275	273
Total Stage 1 PV costs \$M	591	699	1,050	666	779	806

Table 6: 20 year present value cost of losses, impact of reliability and life cycle costs for the selected DC undersea cable Stage 1 transmission options for a 25% capacity factor.

Option	C3-2	A3-2	A1-2	B3-2	C1-2	B1-2
Description	400 MW Koolau to Molokai	200 MW Molokai to Koolau, 200 MW Molokai to Iwilei	200 MW Molokai to Koolau, 200 MW Lanai to Iwilei, 200 MW Lanai to Molokai	400 MW Molokai to Iwilei	200 MW Molokai to Koolau, 200 MW Lanai to Koolau	200 MW Molokai to Iwilei, 200 MW Lanai to Iwilei
Total Stage 1 Price \$M	388	468	781	455	504	533
PV Losses \$M	192	201	209	194	205	208
PV (LOLE) Reliability \$M	48	72	87	55	98	95
PV Life cycle costs \$M	42	42	62	42	62	62
Total PV Operating Costs \$M	282	315	358	291	365	365
Total Stage 1 PV costs \$M	670	783	1,139	746	869	898

The higher present value operating costs of Table 6 with lower 25% capacity factor for the wind generation compared to the operating costs in Table 5 with its 35% capacity factor is due to the higher cost charged for make-up energy for the lower capacity factor. This is 15c/kwh for 35% capacity factor in Table 5 and at 25c/kwh for 25% capacity factor in Table 6.

Due to the assumptions made for establishing losses, reliability and operating costs for the dc cables and converter stations (Appendix A), the values presented for total present value operating cost in Tables 5 and 6 are useful as a guide only. The results do indicate however that operating costs can be significant.

### ***Independent Option***

An independent option was offered by one of the HVDC equipment suppliers as shown in Figure 11. No configuration for Stage 2 was provided.

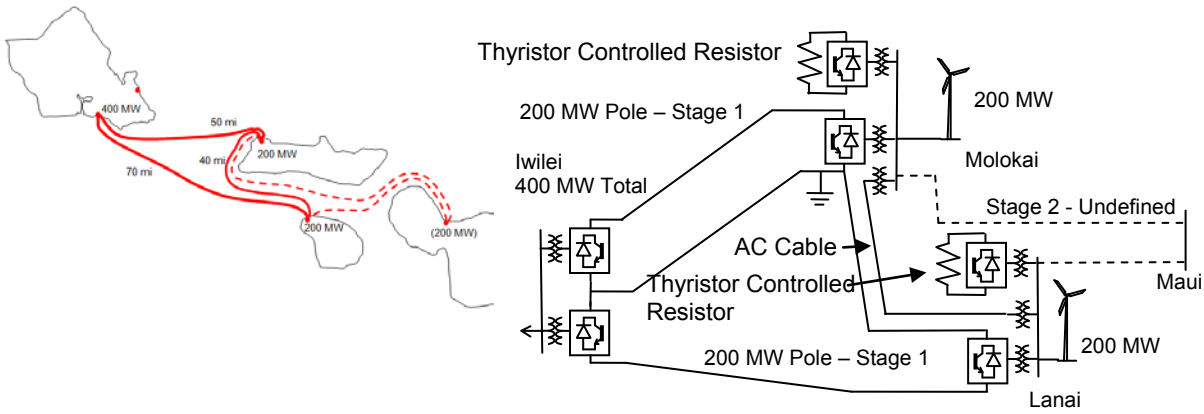

Figure 11: Independent HVDC Option

This option proposes thyristor-controlled resistors on the AC busbars at the wind farms on Molokai and Lanai. These are provided since loss of one pole of the bipolar HVDC feeder to Iwilei will cause the remaining operational pole to overload through the AC cable connection between Lanai and Molokai. Wind farm power under heavy wind conditions still maintains its level of generation until tripped or reduced generation of wind power. With one pole to Iwilei out of service, this power will initially pass through the remaining pole causing it to overload. The thyristor-controlled resistors are designed to absorb excess power temporarily until the excess wind generation can be safely removed off-line.

The Stage 2 development might best be applied as a single symmetrical monopole or with a three core AC cable from Maui to Lanai if the seabed depth is shallow enough. Power transfers with Oahu could be applied through the bipole from Lanai and Molokai to Iwilei from the interconnection at Lanai. However, with just two HVDC poles into Iwilei, the overall bipole rating should not be increased where loss of a pole exceeds the single contingency limit, at present established at 200 MW.

The major contribution of the Independent HVDC Option is the termination at Lanai of the Stage 2 cable transmission circuit from Maui. There is a significant savings in Stage 2 undersea cable capital costs by not laying 70 miles of cable between Lanai and Iwilei (approximately \$178 million). This limits the power import into Oahu from Maui to the capacity of the Stage 1 transmission minus the power being generated by the wind farms. With a wind farm capacity factor of 35%, there will be significant times when power can be

imported directly into Oahu from Maui. This will increase the capacity factor on the Stage 1 cable transmission to Oahu, thereby increasing its cost effectiveness.

There will be no restriction for when power can be imported into Maui from the wind farms on Lanai and Molokai or directly from Oahu. A capacity limitation will be set by the ability of the electric power system on Maui to survive a single contingency loss. For this analysis, a 200-MW limit was applied, but additional study is required to determine what the Maui single contingency loss level is. When known, the initial rating of the cable transmission out of Maui can be determined.

To compare what impact terminating the Stage 2 cable transmission from Maui at Lanai instead of Oahu, options B1-2 and C1-2 are selected. These two options have a 200-MW Stage 1 symmetrical monopole on Lanai. Stage 2 from Maui is terminated at Lanai as shown in Figure 12. No cable transmission is applied between Lanai and Molokai for this assessment.

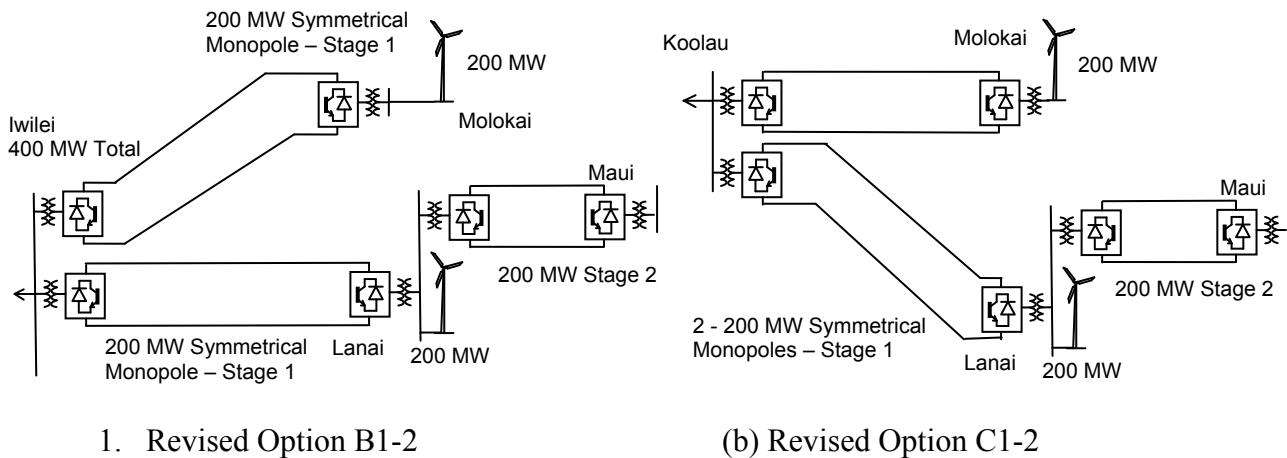

Figure 12: Terminating Stage 2 cable transmission at Lanai instead of Iwilei

The capital costs of the Independent HVDC Option compared with selected Options B1-2 and C1-2 when the Stage 2 cable transmission is terminated at Lanai instead of at Iwilei is presented in Table 7.

Table 7: Capital costs for the Independent HVDC Option compared with Options B1-2 and C1-2

Option	Independent	B1-2	B1-2-Revised	C1-2	C1-2-Revised
Description	200 MW Molokai to Iwilei, 200 MW Lanai to Iwilei, Stage 2 Maui to Lanai	200 MW Molokai to Iwilei, 200 MW Lanai to Iwilei, Stage 2 Maui to Iwilei	200 MW Molokai to Iwilei, 200 MW Lanai to Iwilei, Stage 2 Maui to Lanai	200 MW Molokai to Koolau, 200 MW Lanai to Koolau, Stage 2 Maui to Iwilei	200 MW Molokai to Koolau, 200 MW Lanai to Koolau, Stage 2 Maui to Lanai
Stations \$M	261	288	288	288	288
Cables \$M	424	245	245	216	216
Total Stage 1 Price \$M	685	533	533	504	504
Stage 2 Maui to Oahu (Approx)					
Converter Stations \$M	144	144	144	144	144
DC Cables \$M	94	272	94	272	94
Total Stage 2 Price \$M	238	416	238	416	238
Total Stages 1 & 2 \$M	923	949	771	920	742

If the termination of Stage 2 at Lanai and/or Molokai is acceptable, then the significant savings in capital costs can be achieved as the results in Table 7 indicate. Further savings in capital costs and converter station losses will be achieved if the Stage 2 HVDC cable transmission is connected in multi-terminal transmission from Maui to Lanai to Oahu. Further work is needed to investigate the options for terminating the Stage 2 cable transmission from Oahu at Lanai, to include impacts of losses, risk, and technical requirements.

## Technical Study

The study for this project is based on a technical analysis of the six previously identified DC Cable transmission options and routes for a transmission expansion with interconnections between four of the State of Hawaii’s Islands, consisting of Lanai, Oahu, Maui, and Molokai. The six options are presented in Figures 3 to 8 and the details and selected results of the



Technical Study are in Appendix C. The technical study was undertaken for the Stage 1 DC Options only as represented in Figures 3 to 8.

### ***Objectives***

The scope of this effort is to extend the body of work currently developed by the OWITS project teams [1], [2] and further evaluate the suitability and feasibility of the preferred options determined in Appendix A. Assessment is made of the recommended technology of HVDC Voltage Sourced Converters (VSC) cable transmission to connect between Oahu, Lanai and Molokai and Maui, although additional work is being conducted to refine this analysis. The study considers a means to safely operate wind farms on the Molokai, Lanai and Maui through VSC feeders. When more information is known on the Stage 2 interconnection to Maui including its power system, further work will be required to develop the cable transmission that would apply.

### ***Study Considerations***

Potential issues with the connection of the wind plant and the VSC cable transmission system are studied assuming wind turbines are designed with state-of-the-art controls. This analysis is performed for two different types of wind turbine systems using DFIG and Full Converter generic models. This work is undertaken with PSCAD<sup>5</sup> that uses a network model translated directly from a PSS/E<sup>6</sup> case by E-TRAN<sup>7</sup>, using both the solved power flow (.raw) and dynamics (.dvr) files. The VSC converter models are also generic but reflect the system control technologies applied by the two main suppliers of this equipment, ABB and Siemens.

The assembled wind turbine and dc link models will respond dynamically in PSCAD and include the effect of control interactions and their damping, both at small signal and large non-linear signal levels.

### ***VSC Converter Control Strategy***

The controls for each pole or symmetrical monopole are separate and independent from any other pole or monopole. This is so each pole of 200 MW is the largest outage that a single component failure can produce.

---

<sup>5</sup> PSCAD is an electromagnetic transients program licensed by Manitoba Hydro

<sup>6</sup> PSS/E is a power flow and transient stability simulation program from Siemens PTI

<sup>7</sup> E-TRAN is a program to translate network data from PSS/E to PSCAD

There are a number of options for configuring the controls of the VSC converters at the wind farm end. What proved to be most effective was to lock the valve firing oscillator to generate 60-Hz alternating voltage and control the AC voltage at the sending end system. This strategy provides the necessary effective short circuit capacity to allow connection of most types of wind turbine generators to the wind farm. This frequency controlling strategy can be expanded to mirror the HECO system frequency at the wind farms on Molokai and Lanai. The benefit in doing this is that if inertia producing wind turbine generators are installed to help in the operation of the HECO grid system, then any modulated power so generated at the wind farms will automatically transfer through the VSC cable transmission into the HECO system.

The VSC converter connected at the receiving end to the HECO grid controls the DC voltage applied to the DC cables. This VSC converter can also provide support to the HECO AC system through several different modes of control selected by the Operator. These are:

1. Reactive Power Control. This will be useful where the AC voltage at the 138-kV interconnection busbars is controlled by the installed HECO facilities such as nearby generators and switched capacitor banks. With the DC converter in a constant reactive power control mode, there is less possibility for voltage control interaction between the DC converter and the nearby generators connected to the HECO system.
2. AC Voltage Control. The AC voltage on the converter station interconnection busbar can be controlled by the voltage sourced converter(s) similar to a STATCOM. A suitable adjustable droop characteristic will be needed to ensure the voltage control coordinates with the existing or other voltage controlling facilities. The speed of the AC voltage controller of the converter will need to be designed to coordinate with the other voltage controlling facilities as well. Voltage control on the Oahu end would be desirable for the HECO system. Especially on the east end where there aren't any "nearby generators" at times. This is one of the benefits assumed from the HVDC system to mitigate voltage issues following contingency events on the Oahu system.
3. Power Factor Control. Such a controller is possible and may be desirable to have if the interconnection agreement specifies a power factor range of operation.

These modes of control can be specified to be delivered with the converters and be set by the System Operator through a SCADA or other remote or local communication link.

### **Most Severe Single Contingency Disturbance**

The most severe single contingency disturbance is an AC bus fault at the terminating interconnection busbar of the DC cable transmission, with delayed clearing which results in a 200-MW pole or monopole being disconnected as shown in Figure 13.

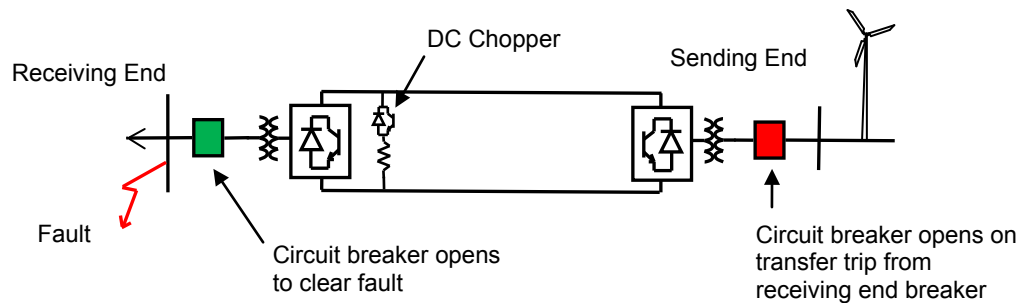

Figure 13: Receiving end fault leaving DC cable open ended at its receiving end

With the fault shown in Figure 13, the power from the wind turbine will continue flowing into the cable through the converter at the sending (wind farm) end, causing the voltage on the DC cable to rise. Protection against overvoltage on the DC cable is achieved by a supplementary DC chopper circuit as shown in Figure 13. The DC chopper is a resistor that is switched in and out across the receiving end of the cable with a solid state switch.

With a bus fault at one of the terminating busbars of Iwilei or Koolau that trips a 200-MW DC Cable feeder from Molokai or Lanai, the following occurs:

1. The DC voltage on the cable of the tripped pole is contained by the DC chopper
2. The HECO grid system on Oahu is deprived of the 200 MW and should recover as determined by system studies [2].
3. If the 200 MW DC pole that trips out of service is the only feeder to the HECO grid from the wind farm, then all the wind turbine generator units in the wind farm must be transfer tripped out of service. If the DC pole that trips out of service is just one pole of either a bipole or two monopoles from a 400-MW wind farm (such as DC Options C3-2 Figure 3, A3-2 Figure 4, A1-2 Figure 5 or B3-2 Figure 6), then the remaining pole is subject to overload. This overload will be twice its rating if the wind is

operating at its maximum capacity of 400 MW. Consequently a protection has to be designed into the DC Cable system which might be one of:

- Purchase the VSC converters and undersea cables with enough emergency rating to accommodate the overload
- Require that the wind turbine generators have a power order controller that forces production power in the wind farm to a level that the remaining DC pole can transfer under emergency conditions
- Apply a transfer trip to enough operating wind turbine generators to bring the production power of the wind farm to a level the remaining DC pole can transfer.

### ***Impact of Faults on Oahu on the Wind Turbine Generators***

VSC cable transmission provides a buffer to AC system faults at one end significantly impacting the AC system at the other end. The receiving end AC system faults may cause the DC cable voltage to increase, but this is managed by the DC chopper. Consequently because the AC voltage and frequency that the wind farms on Molokai and Lanai are connected to stay relatively steady, the impact to the wind turbine generators on both islands is minimal for a severe AC fault on the HECO grid system on Oahu.

### ***Impact of AC Faults on Molokai or Lanai on the HECO Grid on Oahu***

The consequence of severe AC system faults at Molokai or Lanai on the HECO grid on Oahu is also minimal due to the buffering properties of the VSC cable transmission. If the fault at a wind farm clears without losing the HVDC link or a significant loss of wind turbine generators, the impact at the receiving end will not be significant. If the HVDC system or a large number of wind turbines trip because of the disturbance, then the loss of generation will reflect through to the HECO grid system which will have to adjust accordingly.

During the studies of this disturbance, a control interaction in the form of 60-Hz oscillation was observed. The interaction occurred with DC Option A3-2 (Figure 4) following the clearing of an AC fault on the 33-kV bus of the Molokai wind farm. The two symmetrical monopoles were interacting at their sending end with involvement from the DFIG wind turbine generators. The FC wind turbine generators appeared to not be involved in the interaction.

## **Connection to Local Load on Molokai or Lanai**

A review of the results to disturbances for the various options for DC cable transmission indicate that a steady AC voltage and frequency for the sending end wind farms on Molokai or Lanai is achieved so long as the DC converters remain in operation. This still holds when there is no wind. The VSC cable transmission will feedback power to the wind farms from the HECO grid to maintain the wind turbines in hot standby.

Under these conditions, there is a potential to directly connect from the AC collector system of the wind farms to the local load through a conventional AC substation as shown in Figure 14. However, further more detailed analysis is needed to determine the interconnection requirements, such as the protection requirements, for this option. At a minimum, a transfer trip to the interconnection to the local load will be required when the last VSC transmission pole is taken or forced out of service because the sending end AC voltage and frequency can no longer be maintained. This is a consequence of when the DC cable transmission is forced out of service and the wind farm must be transfer tripped for the same reason.

If it is anticipated that this interconnection to local load is to be the only source of operating generation to the local load, then a standby power supply will be required for when the HVDC link is down. It is not usual for HVDC transmission be the sole source of generation for a utility grid but it has been applied to provide supply to off-shore oil and gas pumping stations. From a capacity planning standpoint, one way to consider the interconnection to local load is as if it is another generator. It is subject to forced and scheduled outages of the DC cable transmission. If two poles or monopoles are connected to the wind farm as with DC Options C3-2 Figure 3, A3-2 Figure 4, A1-2 Figure 5 or B3-2 Figure 6, then the reliability of supply to local load will be significantly increased. Under such circumstances the interconnection from the wind farm may be considered as the only source of generation to local load, if the other technical interconnection issues are analyzed and addressed.

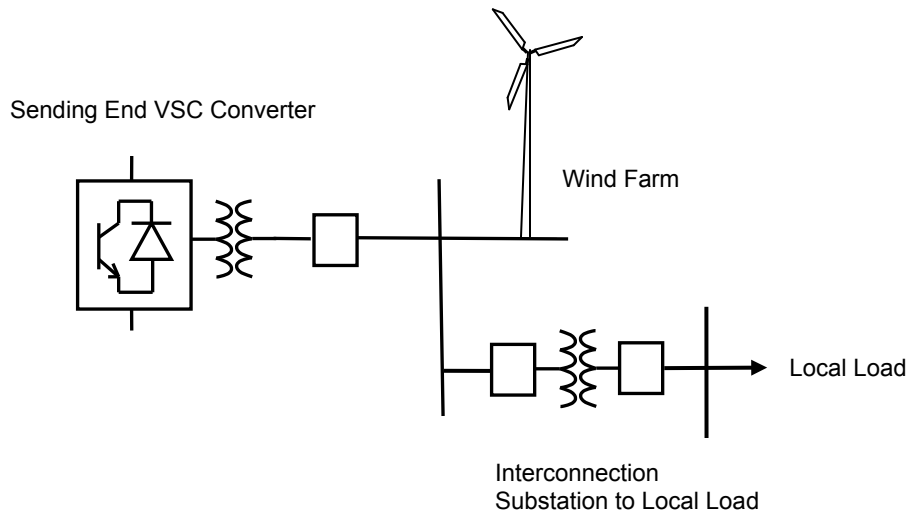

Figure 14: Interconnection to local load

## Conclusions

From this study, the following conclusions can be drawn:

1. An AC cable option is only viable if three core XLPE cable can be applied, but which is limited by the depth to which it can be laid because of its weight. Consequently it cannot be considered for a connection between Lanai or Molokai into Oahu. However, it could be used to interconnect Molokai and Lanai and Maui.
2. Capital costs for the six VSC converter station and DC cable options have been provided by cable and HVDC equipment suppliers. There was considerable variation in the capital costs received. The lowest cost option for a Stage 1 development of 400 MW of wind energy was Option C3-2 (Figure 3) with wind energy developed only on Molokai. This is because the undersea cables are the shortest and therefore the lowest cost.
3. If the Stage 2 cable transmission from Maui can be terminated at Lanai and/or Molokai instead of Oahu, then significant savings in Stage 2 costs can be achieved. This will reduce the power transfer capability from Maui into Oahu when the wind turbine generators on Lanai are generating. There will be less restriction in power transfer capability from Oahu to Maui due to back-feed against the normal flow into Oahu.

4. Voltage sourced converters are the only practical converters to apply with the DC cables. This is because they can create a stable AC supply for wind turbine generators to connect into. They also offer a significant buffer to AC system faults at one end adversely impacting the AC system at the other end. The wind turbine generators on Molokai and Lanai will not be affected significantly by severe AC system faults on Oahu.
5. Careful design is required for the DC cable and converters to ensure that when the DC cable transmission is tripped out of service at its receiving (Oahu) end, that DC cable overvoltage is prevented and the wind turbine generators that lose their path to the load are effectively and quickly removed from operation.
6. With a suitable control strategy for the VSC transmission, it will be possible to maintain a steady AC voltage and frequency for the sending end wind farms. This means that a direct and conventional interconnection to the small local loads on Molokai or Lanai may be an option, but requires further careful design as this is not usual for HVDC transmission to be the sole source of generation for a utility grid. It is only when the DC cable transmission is completely taken out of service that the interconnection to local load would have to be transfer tripped.

## References

1. R.W. Beck, "Hawaii Inter-Island Cable Study", Draft report to the Department of Energy, May 15, 2009.
2. Electric Power Systems, Inc., "OWITS TRC Update", PowerPoint Presentation , April 16, 2005.
3. J. Dorn, H. Huang, D. Retzman, Siemens "Novel Voltage-Sourced Converters for HVDC and FACTS Applications", CIGRE 2007 Osaka Symposium, Paper 314.
4. S. Hirano, J. Haraguchi, T. Mizuno, H. Niinobe, Y. Nagoya, "Development of +/-250 kV Coaxially-Integrated Return Conductor Extruded Insulation Cable," CIGRE 2007 Osaka Symposium, Paper 316.
5. G. Evenset, B. Ladegaard, of Nexans, Norway AS, "Deep Water Cable Solutions – Cable System Development and Installation", Paper 501, CIGRE SC B4 2009 Bergen Colloquium.
6. M. Marelli, A. Orini, G. Miramonti, G. Pozzati of Prysmian, Italy, "Challenges and Achievements for New HVDC Cable Connections", Paper 502, CIGRE SC B4 2009 Bergen Colloquium.
7. ABB AB, "Technical Description of HVDC Light Technology", <http://search.abb.com/library/Download.aspx?DocumentID=1JNL100105-122&LanguageCode=en&DocumentPartID=&Action=Launch&IncludeExternalPublicLimited=True>

## **List of Appendices**

***Appendix A: Selection of Preferred Options for the Inter-island Transmission***

***Appendix B: Evaluation of SVC Requirement for Inter-island AC Cable Option***

***Appendix C: Simulation Studies for Inter-island DC Cable Options***

***Appendix D: Request for Information from DC Converter and Cable Manufacturers***



## APPENDIX A

### *Selection of Preferred Options for the Inter-island Transmission*

Updated May 2010

#### **Introduction**

Eighteen inter-island AC and DC transmission options have been prepared for reduction to 7 cases for further study. There are a number of assumptions that the creation of these 18 cases have been based on, and a presented here for further scrutiny:

1. Oahu receiving points: 200 MW Iwilei and 200 MW Koolau,  
400 MW Iwilei or 400 MW Koolau
2. Lanai and Molokai sending points: 200 MW Lanai and 200 MW Molokai,  
400 MW Lanai or 400 MW Molokai
3. Maximum N-1 outage possible: 200 MW
4. 5 years after Lanai and Molokai interconnections are in operation, a 200 MW interconnection from Maui to Oahu is put in place. This study assumed a 200 MW Stage 2 interconnection to Maui could be made, but this is to be reviewed before the Stage 2 options to Maui are finalized.
5. When the Lanai and Molokai interconnections terminate at the one location, either Iwilei or Koolau, the Maui to Oahu termination is located at Iwilei when the 400 MW termination is at Koolau, and at Koolau when the 400 MW termination is at Iwilei.
6. A practical rating for the AC cables is 230 kV, 250 MW maximum, 3 core XLPE cable. This is ideally suited for the AC options for this project. The reactive power charging requirement for this cable is about 4.8 MVAR per mile, which is manageable for these applications. 3 core cables of larger capacity have not been made available by cable suppliers largely because their size becomes challenging to transport and lay.
7. For the DC options, 150 kV cables are proposed, either as symmetrical monopoles rated at 200 MW or 400 MW bipole when possible, assuming the poles of the bipole are independent so that the N-1 outage remains at 200 MW.
8. The 18 options are all radial feeds with no more than a 200 MW single contingency. To reduce the single contingency outage to 0 MW, the added cables and ratings needed are difficult to justify.

The method of elimination and reduction to the preferred options undertook the following assessments:

1. Capital cost, including present value analysis of incorporating the Maui interconnection 5 years after the Lanai/Molokai interconnections are in-service
2. Simple loss analysis. The loss analysis would be based on say a 20 year operating period.
3. Reliability Assessment. Outages for cables, transformers and converters were assumed as in Table A-3. It is not possible to predict future cable failures. A failure rate and repair time to the equipment is assigned that meets expectations for cable operation. Such an assessment is to determine what spares are required.

## **Impact of Losses**

The cost of losses are capitalized to a present value and added to the capital costs. The assumptions for the loss analysis are as follows:

1. The cost of losses is to be assessed at 15¢/kWhr for a load capacity factor on the cables from the wind energy sources at 35% and at 25¢/kWhr for a load capacity factor of 25%.
2. For convenience of basic analysis, losses are divided into “fixed” and “variable”. Fixed losses, also known as no-load losses are voltage dependent and are considered to remain fixed or unchanged as long as the cable is energized. Variable losses are proportional to the square of the current or loading on the cable transmission.
3. When no power is flowing through the cable transmission, it remains energized where fixed losses are present but variable losses are zero.
4. Variable losses are dependent on the load capacity factor. For the purpose of this loss assessment, the load capacity factor for the cable transmission to Oahu from Lanai, Molokai and Maui is considered as a straight line characteristic as shown in Figure 1.

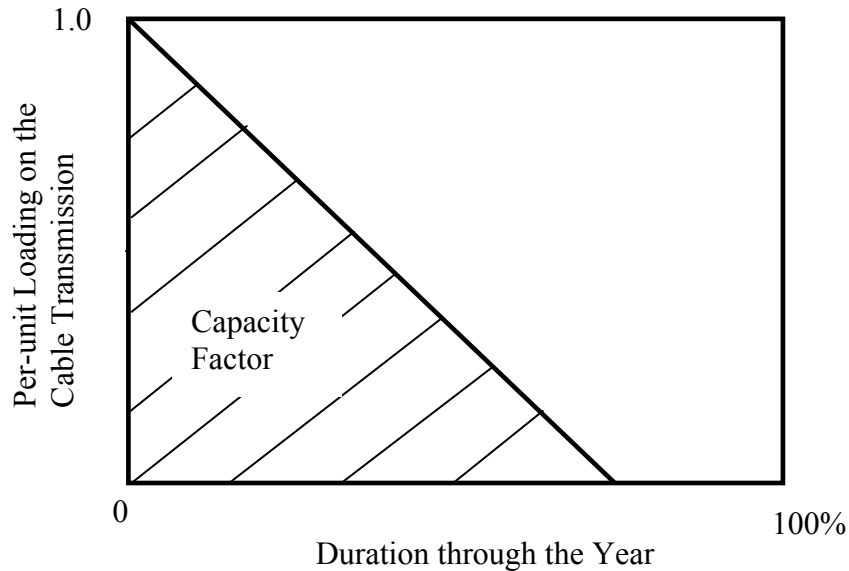

Figure A-1: Representation of the annual load capacity factor for variable loss analysis. Capacity factor is the shaded area as a percentage of the total area of full load for one year.

5. VSC converter station fixed losses are assumed to be 0.75% of a converter station rating and variable losses are 0.45% of converter station rating. The DC cable is assumed to only have variable losses. The AC cable accumulates fixed losses due to circulating charging currents at no-load and losses in the dielectric, and variable losses that accumulate in the main conductor, the shield and armor. Use of cables with higher losses will impact cable option preference since losses play a significant role in overall present value costs.
6. The shunt compensating reactors at the ends of the AC cables are not switchable, and their fixed losses are based on an X/R ratio of 70. No SVC or dynamic compensation is applied for the AC cable options.
7. The loss accumulation for the Stage 1 development of cable transmission from Lanai and Molokai is assumed over 20 years and the present value of these losses is capitalized to year 1. The discount rate is applied at 5% p.a. The loss evaluation for Stage 2 cable transmission from Maui to Oahu is assessed over years 6 to 20, and the present value is capitalized to year 1. The capitalized value of losses is then added to the capital cost of the option.
8. In general, the loss of any one element is limited to 200 MW. For those DC options where 400 MW is to be delivered to the one site on Oahu from Molokai or Lanai, then a bipolar option is considered. This requires the laying of three cables, where one cable serves as a metallic return path. Each pole is independent of the other, and the DC pole cables need not be laid together to avoid common mode failure. Under such a configuration, an outage will be limited to 200 MW. The bipolar 400 MW

configuration is possible for most options studied. This means the DC cables at 150 kV are rated for 1,333 amp rather than 667 amp.

### Capital Cost Summary Including Losses

The capital cost summary of the eighteen options is presented in Table A-1 for the cost of losses at 15c/kWh and 35% capacity factor. The cost summary is repeated in Table A-2 for the cost of losses at 25c/kWh and 25% capacity factor.

Table A-1: Cost summary of options for the Oahu Wind Integration and Transmission Study for 15¢/kWh cost of losses and 35% capacity factor.

Option	AC or DC	Description	\$M Capital Cost	\$M Present Value Loss 15c/kWh 35% CF	\$M Total
A1-1	AC	200MW, Koolau - 200 MW, Lanai - 200 MW, Molokai - 200 MW	880	311	1191
<b>A1-2</b>	<b>DC</b>	“ “ “ “	<b>711</b>	<b>179</b>	<b>890</b>
A2-1	AC	Iwilei - 200MW, Koolau - 200 MW, Lanai - 400 MW	973	381	1354
A2-2	DC	“ “ “ “	809	186	995
A3-1	AC	Iwilei - 200MW, Koolau - 200 MW, Molokai - 400 MW	787	270	1057
<b>A3-2</b>	<b>DC</b>	“ “ “ “	<b>698</b>	<b>172</b>	<b>870</b>
B1-1	AC	Iwilei - 400MW, Lanai - 200 MW, Molokai - 200 MW	897	311	1208
B1-2	DC	“ “ “ “	770	187	957
B2-1	AC	Iwilei - 400MW, Lanai - 400 MW	966	376	1342
B2-2	DC	“ “ “ “	823	181	1004
B3-1	AC	Iwilei - 400MW, Molokai - 400 MW	831	295	1126
<b>B3-2</b>	<b>DC</b>	“ “ “ “	<b>739</b>	<b>176</b>	<b>915</b>
C1-1	AC	Koolau - 400MW, Lanai - 200 MW, Molokai - 200 MW	892	323	1215
<b>C1-2</b>	<b>DC</b>	“ “ “ “	<b>758</b>	<b>185</b>	<b>942</b>
C2-1	AC	Kailau - 400MW, Lanai - 400 MW	983	393	1376
C2-2	DC	“ “ “ “	835	182	1017
C3-1	AC	Koolau - 400MW, Molokai - 400 MW	749	253	1002
<b>C3-2</b>	<b>DC</b>	“ “ “ “	<b>688</b>	<b>173</b>	<b>861</b>

Table A-2: Cost summary of options for the Oahu Wind Integration and Transmission Study for 25¢/kWh cost of losses and 25% capacity factor.

Option	AC or DC	Description	\$M Capital Cost	\$M Present Value Loss 25¢/kWh 25% CF	\$M Total
A1-1	AC	200MW, Koolau - 200 MW, Lanai - 200 MW, Molokai - 200 MW	880	492	1372
<b>A1-2</b>	<b>DC</b>	“ “ “ “	<b>711</b>	<b>276</b>	<b>987</b>
A2-1	AC	Iwilei - 200MW, Koolau - 200 MW, Lanai - 400 MW	973	605	1578
A2-2	DC	“ “ “ “	809	284	1093
A3-1	AC	Iwilei - 200MW, Koolau - 200 MW, Molokai - 400 MW	787	426	1213
<b>A3-2</b>	<b>DC</b>	“ “ “ “	<b>698</b>	<b>267</b>	<b>965</b>
B1-1	AC	Iwilei - 400MW, Lanai - 200 MW, Molokai - 200 MW	897	492	1389
B1-2	DC	“ “ “ “	770	284	1054
B2-1	AC	Iwilei - 400MW, Lanai - 400 MW	966	599	1565
B2-2	DC	“ “ “ “	823	278	1101
B3-1	AC	Iwilei - 400MW, Molokai - 400 MW	831	466	1297
<b>B3-2</b>	<b>DC</b>	“ “ “ “	<b>739</b>	<b>272</b>	<b>1011</b>
C1-1	AC	Koolau - 400MW, Lanai - 200 MW, Molokai - 200 MW	892	511	1403
<b>C1-2</b>	<b>DC</b>	“ “ “ “	<b>758</b>	<b>282</b>	<b>1040</b>
C2-1	AC	Kailau - 400MW, Lanai - 400 MW	983	623	1606
C2-2	DC	“ “ “ “	835	278	1113
C3-1	AC	Koolau - 400MW, Molokai - 400 MW	749	398	1147
<b>C3-2</b>	<b>DC</b>	“ “ “ “	<b>688</b>	<b>268</b>	<b>956</b>

The consideration for losses does not change the lowest capitalized cost options identified in red in Tables A-1 and A-2. The variation of cost of losses from 15¢/kWh to 25¢/kWh does not change the five lowest cost options either. The cost of losses is impacted more significantly by the cost value placed on losses rather than by load capacity factor.

### Description of Preferred Options

Six HVDC options and one AC option are proposed for further analysis and described as follows. The landing locations on the Oahu end of the cable are limited to two locations to simplify the analysis and should not be viewed as the only alternatives for landing sites on Oahu as several are being considered and evaluated in other studies. The results of this study are not significantly impacted by the details of the Oahu landing sites, at least to the extent that sites at or near Koolau in the north and at or near Iwilei in the south may be contemplated.

Landing sites on Molokai and Maui are positioned to avoid breaching live reefs to the greatest extent possible. This adds length to the undersea cable connections between Molokai and Lanai for Stage 1 and to Maui for Stage 2. Further Environmental Impact

Assessment may justify shorter distances for the undersea cables between Molokai, Lanai and Maui, but for this study the longer cable lengths and higher costs will apply.

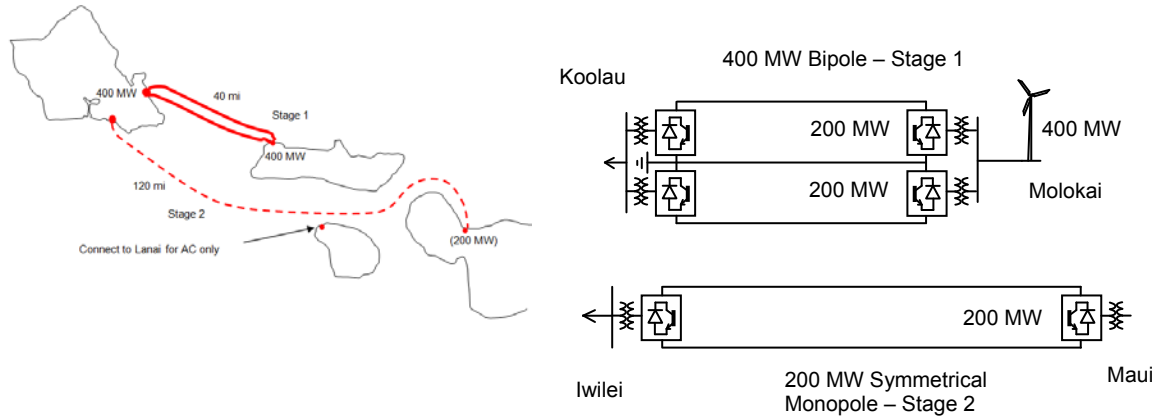

Figure A-2: Option C3-2, \$M718 Present Value Capital Cost. Stage 1 connection from Molokai to Koolau.

The Stage 1, 400 MW HVDC cable transmission between Molokai and Koolau is in  $\pm 150$  kV bipole configuration, requiring three cables to be laid. The Stage 2, 200 MW HVDC cable transmission between Maui and Iwilei is a  $\pm 150$  kV symmetrical monopole configuration, requiring two cables to be laid.

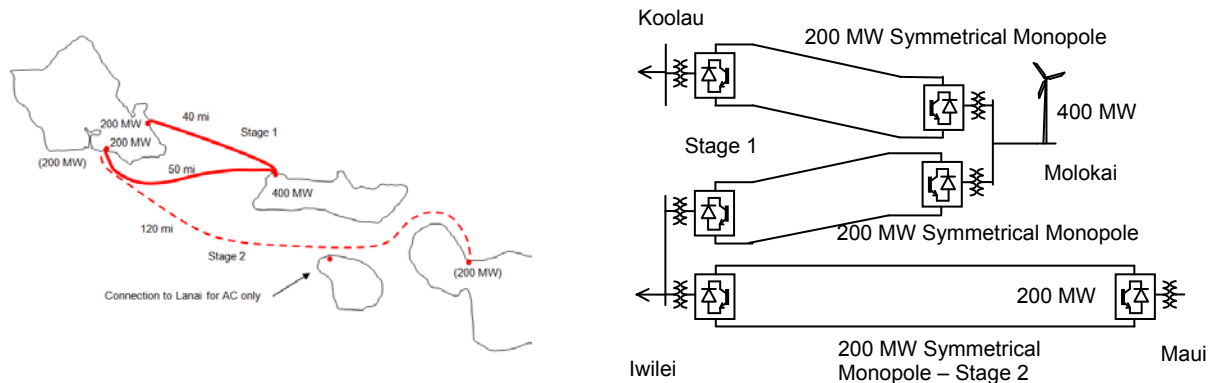

Figure A-3: Option A3-2, \$M728 Present Value Capital Cost. Stage 1 connection from Molokai to Koolau and Iwilei.

The Stage 1, with 2 - 200 MW HVDC cable transmission between Molokai and Oahu to Koolau and Iwilei is a  $\pm 150$  kV symmetrical monopole configuration, requiring four cables to be laid. The Stage 2, 200 MW HVDC cable transmission between Maui and Iwilei is in  $\pm 150$  kV symmetrical monopole configuration, requiring two cables to be laid.

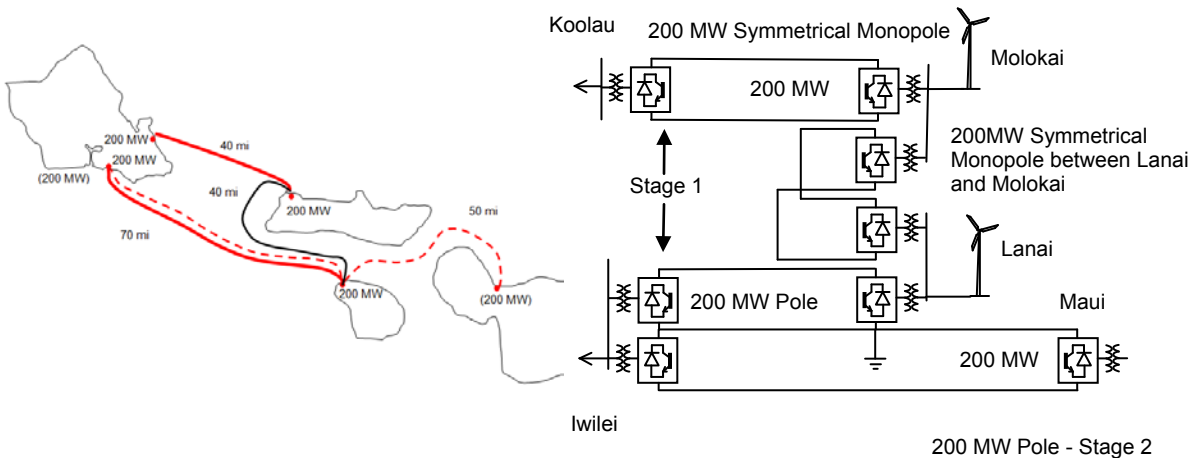

Figure A-4: Option A1-2(a): \$M827 Present Value Capital Cost – With DC cable between Lanai and Molokai

Stage 1 has a 200 MW HVDC cable symmetrical monopole transmission between Molokai and Oahu to Koolau. From Lanai to Iwilei on Oahu is a 150 kV pole, 200 MW configuration, with two cables, of which one is a metallic return cable. For Stage 2, a 200 MW HVDC cable transmission between Maui and Iwilei is the other pole at -150 kV, requiring two cables to be laid from Maui to Lanai, with one cable extending to Lanai.

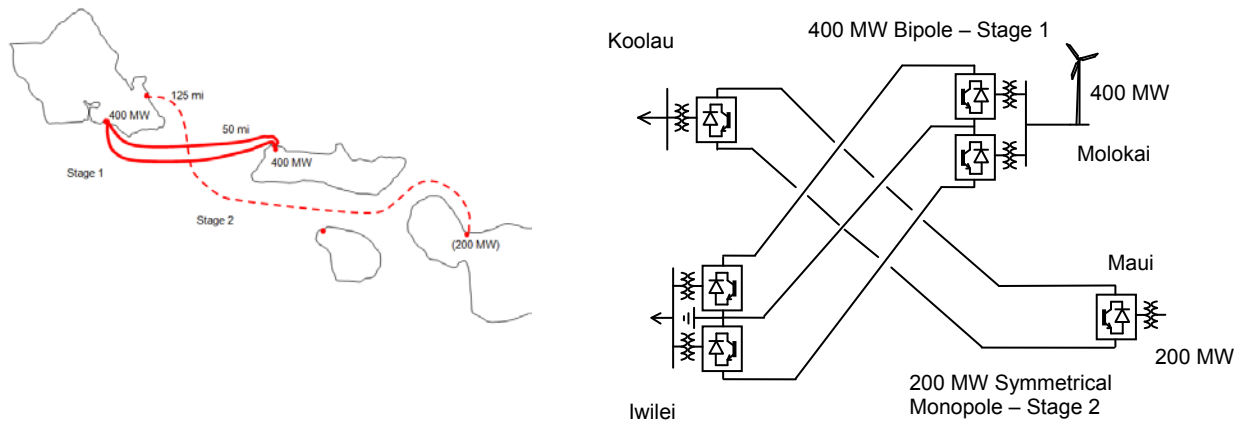

Figure A-5: Option B3-2: \$M770 Present Value Capital Cost. Stage 1 connection from Molokai to Iwilei

The Stage 1, 400 MW HVDC cable transmission between Molokai and Iwilei is a  $\pm 150$  kV bipole configuration, requiring three cables to be laid. The Stage 2, 200 MW HVDC cable transmission between Maui and Koolau is a  $\pm 150$  kV symmetrical monopole configuration, requiring two cables to be laid.

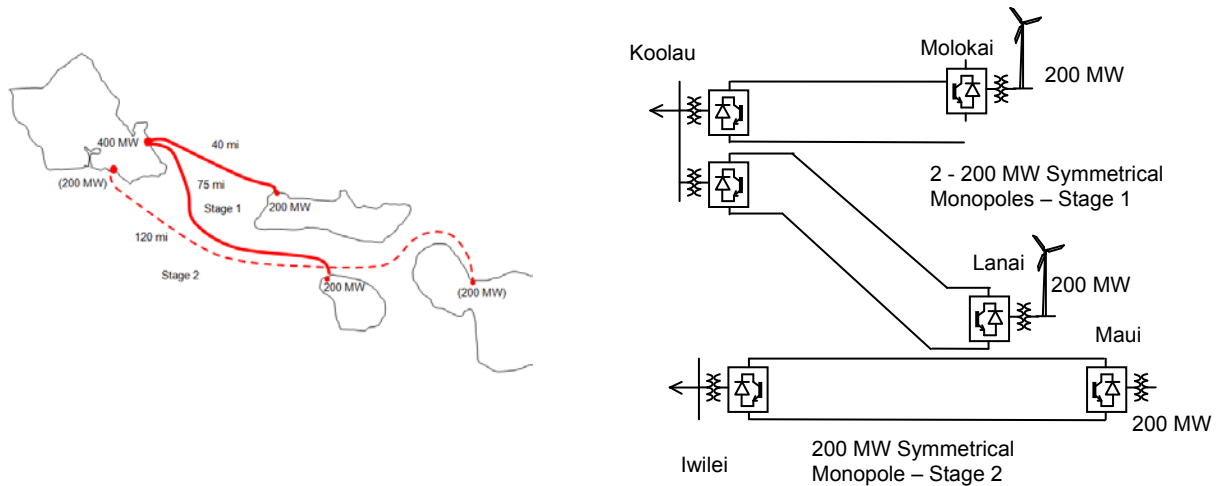

Figure A-6: Option C1-2: \$M788 Present Value Capital Cost. Stage 1 connection from Molokai and Iwilei to Koolau

Stage 1, consists of 200 MW,  $\pm 150$  kV HVDC symmetrical monopole cable transmission between Molokai and Koolau and also between Lanai and Koolau, each requiring two cables to be laid. For Stage 2, a 200 MW HVDC  $\pm 150$  kV HVDC symmetrical monopole cable transmission between Maui and Iwilei requires two cables to be laid.

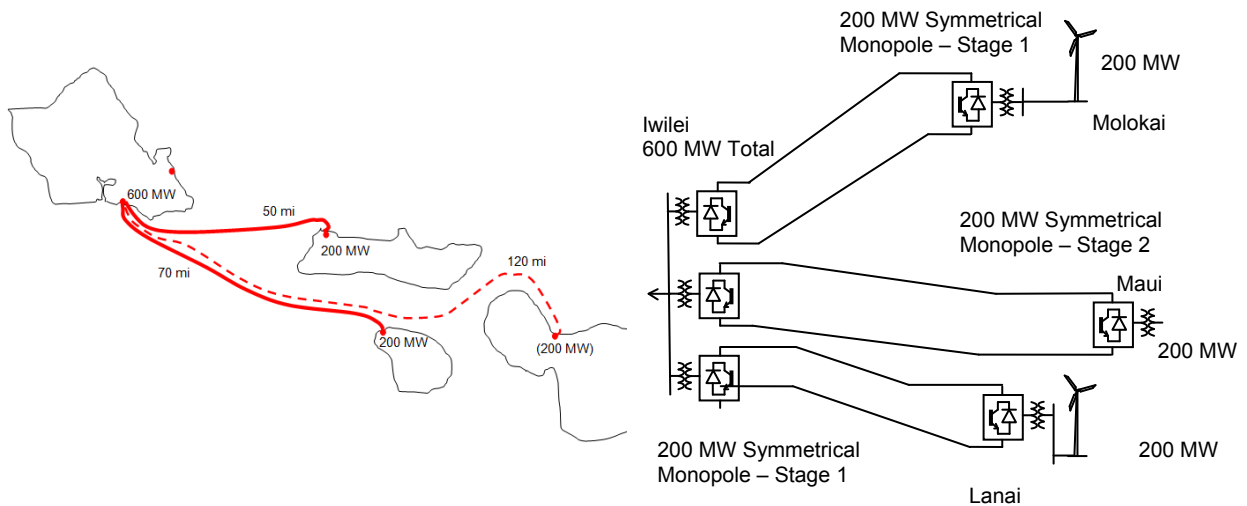

Figure A-7: Option B1-2: \$M800 Present Value Capital Cost (revised). Stage 1 connection from Molokai and Lanai to Iwilei

Stage 1, consists of 200 MW,  $\pm 150$  kV HVDC symmetrical monopole cable transmission between Molokai and Iwilei and also between Lanai and Iwilei, each requiring two cables to be laid. For Stage 2, a 200 MW HVDC  $\pm 150$  kV HVDC symmetrical monopole cable transmission between Maui and Koolau requires two cables to be laid.



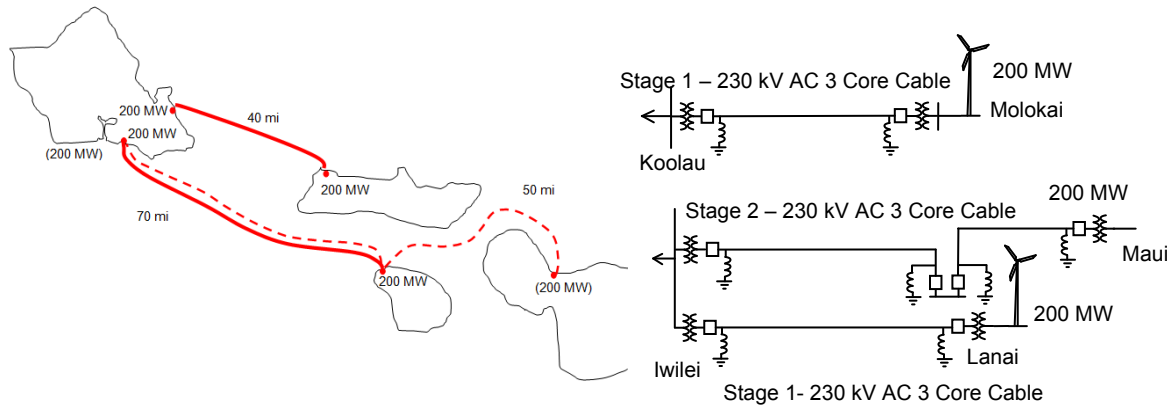

Figure A-8: Option A1-1: \$M917 Present Value Capital Cost. Stage 1 connection from Molokai to Koolau and from Lanai to Iwilei.

Stage 1, consists of 200 MW, 230 kV AC 3 core XLPE cable transmission between Molokai and Koolau and also between Lanai and Iwilei, each requiring one 3 core cable to be laid. For Stage 2, a 200 MW, 230 kV AC 3 core cable transmission between Maui and Iwilei is required with a reactor station on Lanai.

The preferred options with VSC converters on Molokai and Lanai for Stage 1 and on Maui for Stage 2 will tightly regulate AC system frequency on these islands to the extent that they can connect directly to local load through conventional AC substations.

The assumption that the Maui interconnection is rated at 200 MW has a large impact on Stage 2 costs. This requires an undersea cable rated to 200 MW for the full and lengthy distance from Maui to Oahu in order to be within the 200 MW N-1 restraint on Oahu. As a consequence, the cable options are all radial in order to maintain minimum costs.

## Impact of Reliability

The main components of cable transmission are subject to failure, so that when a failure does occur usually results in loss of delivered energy. It is not possible to predict future failure of equipment for the OWITS Project. All we can do in this respect is assign a failure rate and repair time to the equipment that meets our expectation for cable operation. Variations to the selected failure rates and repair times can be made to evaluate sensitivity of the energy delivery to cable transmission outage.

The base unscheduled failure rates and repair times are proposed as listed in Table A-3. These values do not include usual increased failure rate that might be experienced during the first year of operation. They are only indicative of what may be expected of the undersea cable performance.

Table A-3: Base failure rates and repair times for undersea cable transmission to Oahu

Equipment	Failure Rate	Repair Time	Forced Outage Rate $q$	Frequency of Outage $\lambda$
Transformer	1 outage/20 yr	2 weeks	0.001923	0.05
1 – 200 MW VSC converter	1 outage/yr	6 hours	0.000685	1
1 – 150 kV dc cable	1 outage/100 mi/40 yr	18 months	0.05	0.0333
1 – 230 kV ac cable	1 outage/100 mi/40 yr	18 months	0.05	0.0333
1 – set of compensating reactors	1 outage/20 yr	2 weeks	0.001923	0.05

Forced Outage Rate  $q$  is defined as: 
$$q = \frac{\text{(Time on forced outage)}}{\text{(Time exposed to forced outage)}}$$

A basic application of the binomial probability theorem is undertaken as outlined by Billinton<sup>8</sup> to evaluate impact of forced outages on energy delivered as well as assess the need for spare cables. For the purpose of this evaluation, only Stage 1 development (excluding the Stage 2 cable transmission from Maui) is considered. The capacity factors for the transmission and the costs of lost energy are the same as applied for the loss evaluation. These are 15¢/kwh at a capacity factor of 35%, and 25¢/kwh at a capacity factor or 25%. A straight line load capacity factor curve is applied.

Other assumptions are:

1. The failure rate for the 3 core AC cable is the same as one HVDC pole cable. This is an oversimplified assumption biased in favor of the AC cable. However, there is no service record for the 3 core AC cable applied since very few if any are in service at 230 kV. Failure in a single cable, whether single core coaxial HVDC or 3 core XLPE AC cable will be subject to similar failure mechanisms such as defective splicing, ground disturbances, anchors or fishing apparatus. Hence the justification for similar failure rates for each type of undersea cable.
2. Failures in the DC cables are considered independent events. In otherwords, failure in either a pole or metallic return DC cable will not affect the other cable or cables for that symmetrical monopole or bipole. However, if one of the DC cables of a symmetrical monopole fails, the whole symmetrical monopole is removed from service. If one of the DC cables of a bipole with metallic return fails, only one pole is removed from service, and operation continues at half power on the other pole.

The loss of energy delivered (usually designated loss of load expectation or LOLE) for each of the preferred options is assembled into Table A-4. This LOLE energy is costed both at 15c/kwh (35% capacity factor) and at 25c/kwh (25% capacity factor) for a 20 year present value accumulation at a discount rate of 5%.

<sup>8</sup> R. Billinton, *Power System Reliability Evaluation*, Gordon and Breach, 1970.

Table A-4: Energy lost and its present value cost

<b>Preferred Option (Stage 1)</b>		<b>1 yr LOLE 35% CF MWh</b>	<b>1 yr LOLE 25% CF MWh</b>	<b>PV at 15c/KWh \$M</b>	<b>PV at 25c/KWh \$M</b>
C3-2	400 MW Molokai to Koolau - DC	21,702	15,511	40.6	48.3
A3-2	200 MW Molokai to Koolau, 200 MW Molokai to Iwilei - DC	32,287	23,077	60.4	71.9
A1-2	200 MW Molokai to Koolau, 200 MW Lanai to Iwilei - DC	38,962	27,849	72.8	86.8
B3-2	400 MW Molokai to Iwilei - DC	24,873	17,778	46.5	55.4
C1-2	200 MW Molokai to Koolau, 200 MW Lanai to Koolau - DC	44,182	31,581	82.6	98.4
B1-2	200 MW Molokai to Iwilei, 200 MW Lanai to Iwilei - DC	42,483	30,366	79.4	94.6
A1-1	200 MW Molokai to Koolau, 200 MW Lanai to Iwilei - AC	22,240	15,896	41.6	49.5

### **Possibility for Spare Cable**

The cost of a DC cable for this exercise is estimated at \$M2.4/mi and \$M3.36/mi for a 3 core AC cable. These costs are based on file values for similar undersea cables with the main factor being cable weight. Hence the higher cost for the 3 core AC cable compared to the lighter solid insulated DC cable. For the 40 mile between Molokai and Koolau, this would be \$M96 for the DC cable and \$M134 for the AC cable. For the most preferred case C3-2 where both circuits of Stage 1 are between Molokai and Koolau, the present value cost of replacement energy indicated in Table A-4 of \$M40.6 to \$M48.3 would not justify the cost of a spare cable. This same conclusion extends to all preferred options.

A spare cable could be operated in parallel with one of the main cables to reduce losses to help justify its cost. The spare DC cable between Molokai and Koolau reduces the variable losses for just the cables from 2.5 MW to 1.9 MW. At 25c/kwh, 25% capacity factor and present value for 20 years, this saving in losses results in less than \$M4 present value saving, which does little to justify its need.

## Cable Connection Between Lanai and Molokai

The benefit of adding a cable between Lanai and Molokai for the options it could apply was investigated and an example is included in option A1-2. A 200 MW symmetrical monopole was selected with its individual converters. There is the option of applying a multi-terminal HVDC configuration to avoid the capital cost of the independent converters. However, a cable or dc side fault might fail the operation of both the Lanai to Oahu and Molokai to Oahu cables resulting in a 400 MW loss.

The undersea route selected circumnavigated the west coast of Molokai to avoid the reef. A distance of 40 miles was applied justified to avoid breaching the reef. The earlier study<sup>9</sup> assumed it was acceptable to cross through the reef but this needs to be justified by environmental impact study. The savings in replacement energy to Oahu was not significant to warrant the expense. Additional justification will be needed to consider this cable.

## Summary

The present value of capital costs, losses and reliability effects for the selected options with revisions are summarized in Table A-5.

Table A-5: Comparison of Present Value Costs for selected options:

Preferred Option (Stage 1)		Present Value Capital Cost \$M	PV Losses \$M		PV Reliability \$M		Total \$M	
			15c/kwh	25c/kwh	15c/kwh	25c/kwh	15c/kwh	25c/kwh
C3-2	400 MW Molokai to Koolau - DC	688	173	268	41	48	902	1004
A3-2	200 MW Molokai to Koolau, 200 MW Molokai to Iwilei - DC	698	172	267	60	72	930	1037
A1-2	200 MW Molokai to Koolau, 200 MW Lanai to Iwilei - DC	711	179	276	73	87	963	1074
B3-2	400 MW Molokai to Iwilei - DC	739	176	272	47	55	962	1066
C1-2	200 MW Molokai to Koolau, 200 MW Lanai to Koolau - DC	758	185	282	83	98	1026	1138
B1-2	200 MW Molokai to Iwilei, 200 MW Lanai to Iwilei - DC	770	187	284	79	95	1036	1149
A1-1	200 MW Molokai to Koolau, 200 MW Lanai to Iwilei - AC	880	311	492	42	50	1233	1422

<sup>9</sup> R.W. Beck, "Hawaii Inter-Island Cable Study", Draft report to the Department of Energy, May 15, 2009

## **APPENDIX B**

### ***Evaluation of SVC Requirement for Inter-Island AC Cable Option***

Updated May 2010

#### **Introduction**

Concern has been expressed by technical parties that isolation of a wind farm with a long AC undersea cable would cause high voltages on the cable and in the wind farm substation, requiring fast dynamic VAR support such as an SVC or STATCOM to be installed. The requirement for an SVC or STATCOM is justified in this study solely on ensuring the AC 3 core cables can be energized and operated so that no unacceptable power quality is created in the Oahu power system. If an SVC or STATCOM is required in the power system on Oahu for system reasons, these have not been considered.

The analysis presented here pertains to Alternative A1-1 (Figure 1). This alternative connects up to 600 MW of wind generation to Oahu via AC under-sea cables with both Stage 1 and Stage 2 development. The landing sites on the islands are simplifying assumptions for comparison purposes and should not be taken as the actual landing sites that will be used as several are being considered and evaluated in other study efforts. These over-voltages are expected to occur especially following the opening of a breaker at the Oahu “receiving” end of the AC cables, effectively isolating the cable and wind farm together from the larger AC network. The breaker opening may be spontaneous or following a close-in or remote fault.

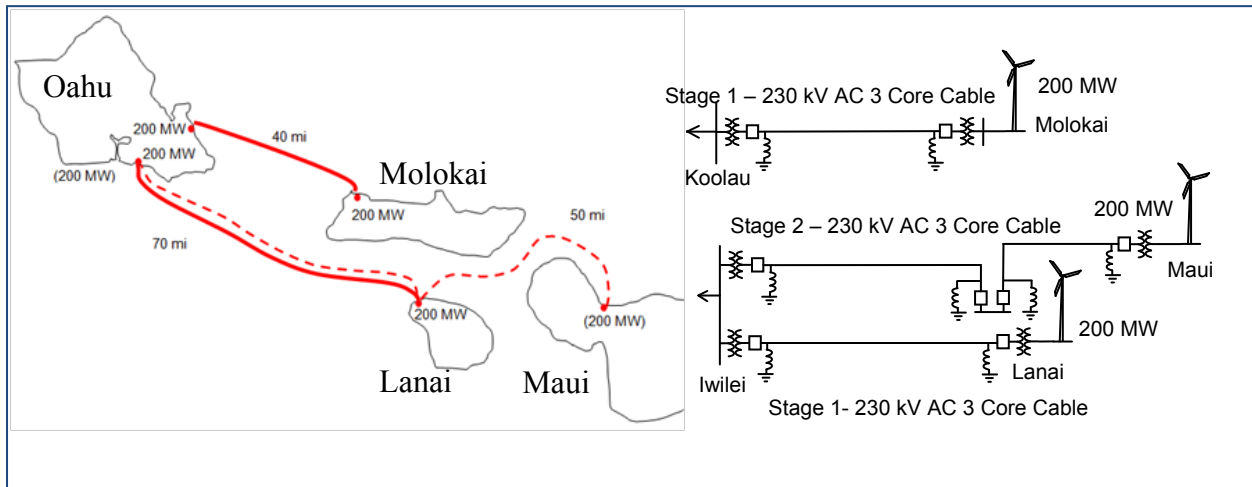

Figure 1 Option A1-1: AC Cable Interconnection Alternative. Stage 1 consists of 200 MW, 230 kV AC 3 core XLPE cable transmission between Molokai and Koolau and also between Lanai and Iwilei, each requiring one 3 core cable to be laid. For Stage 2, a 200 MW, 230 kV AC 3 core cable transmission between Maui and Iwilei is required with a reactor station on Lanai.

## Modeling

All modeling and simulation was performed using electromagnetic transient simulator PSCAD/EMTDC version 4.2<sup>10</sup>. Both Type 3 (doubly-fed induction generator) and Type 4 (generator behind a full converter) wind turbine technologies were considered, and the 3-core XLPE cable was modeled using the longest expected span, between Oahu and Lanai.

Since the objective of this analysis was to determine voltage conditions at the wind farm after the wind farm has been isolated from the network, a simple equivalent model was used to represent steady state conditions prior to breaker opening. It was assumed that a worst case for overvoltage at the wind turbines would be caused by a high impedance fault followed by a breaker opening, or a spontaneous breaker-fail operation.

## Cable Representation

The AC cable was modeled using frequency dependent (phase) models in PSCAD/EMTDC, providing correct transient response over a wide range of frequencies. The cable model is based on the ABB FXBT three-core XLPE cable rated at 733 A and 220/245 kV as shown in Figure 2.

<sup>10</sup> PSCAD/EMTDC is an licensed electromagnetic transients simulator of Manitoba Hydro: <https://pscad.com/products/pscad/>

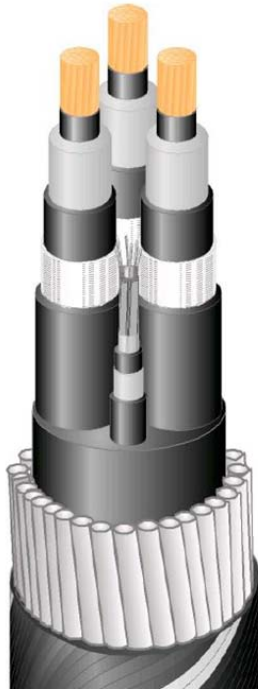

Figure B-2 AC Cable applied for study of 230 kV, 200 MW connection from Lanai to Oahu

The cable as modelled is 100% compensated with shunt reactors to minimize overvoltages due to the Ferranti effect, as well as provide smooth voltages upon energization when energization is performed using a 2 breaker pre-insertion resistor scheme. The cable studied is the 70 mile interconnection between Lanai to Oahu. Since this is the longest section and therefore the most challenging to design for, any conclusion on need for an SVC or STATCOM will be valid for shorter cables.

### **Wind Farm Representation**

Both Type 3 (doubly-fed induction generator) and Type 4 (generator behind a full converter) turbine types were considered. The size of the wind farm was assumed to be 200 MW, which is the largest size expected to be connected radially to the single undersea cable for this project. Detailed generic PSCAD models for each type were scaled to 200 MW. Detailed models included arresters, protection systems, power electronic interfaces and controls, turbine systems, pitch control systems, machine models, and various control modes.

### **Overvoltage Control**

The issue of concern is shown in Figure B-3.

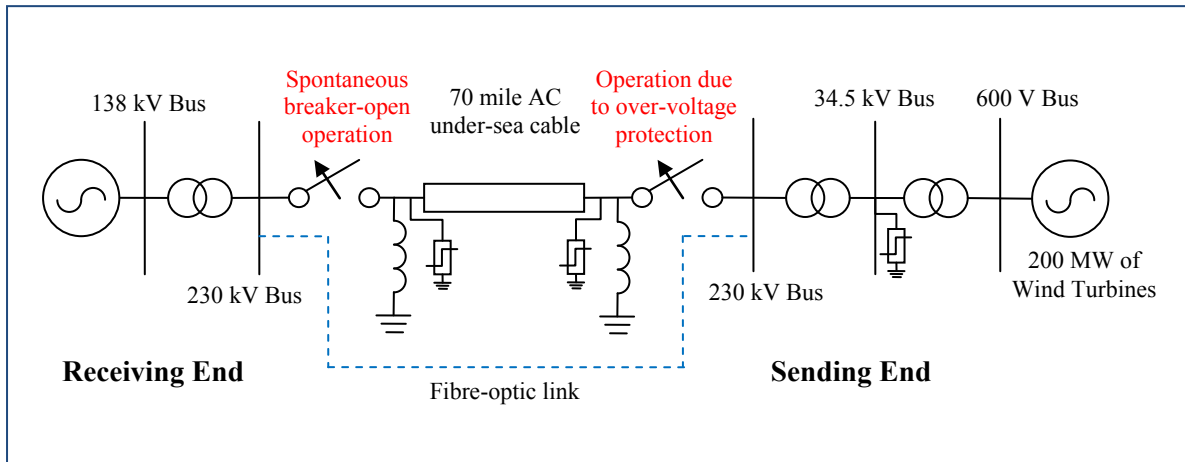

Figure B-3 Simplified One-Line Diagram showing radial connection caused by spontaneous breaker-open event

Figure B-4 and Figure B-5 show simulation results for a breaker-fail condition isolating a 200 MW wind farm with a 70 mile long cable (see Figure 3). For a DFIG turbine (Type 3 - Figure 4), upon spontaneous breaker-open operation (occurring at  $t=5$  seconds in simulation traces), the voltages at both ends of the cable rise to approximately 1.8 pu before the overvoltage protection at the wind farm has time to operate. During this time, surge arresters at both ends of the cable and at the 34.5 kV bus absorb energy to prevent the voltage from rising further. Approximately 3 cycles after the wind farm substation first detects overvoltages, the 230 kV sending end breaker operates. As a redundant protection, a signal is also sent via fiber-optic communication from the receiving end breaker to force open the sending end 230 kV breaker. Approximately 6 cycles after the wind farm substation first detects overvoltages, the 34.5 kV collector feeder breakers and unit protection operates. Full converter type turbines (Type 4) experience milder over-voltage conditions during this disturbance.

Note that voltages on the AC cable following isolation from the system take a significant amount of time to ring down to zero volts, discharging through losses in the cable, shunt reactors, and arresters.



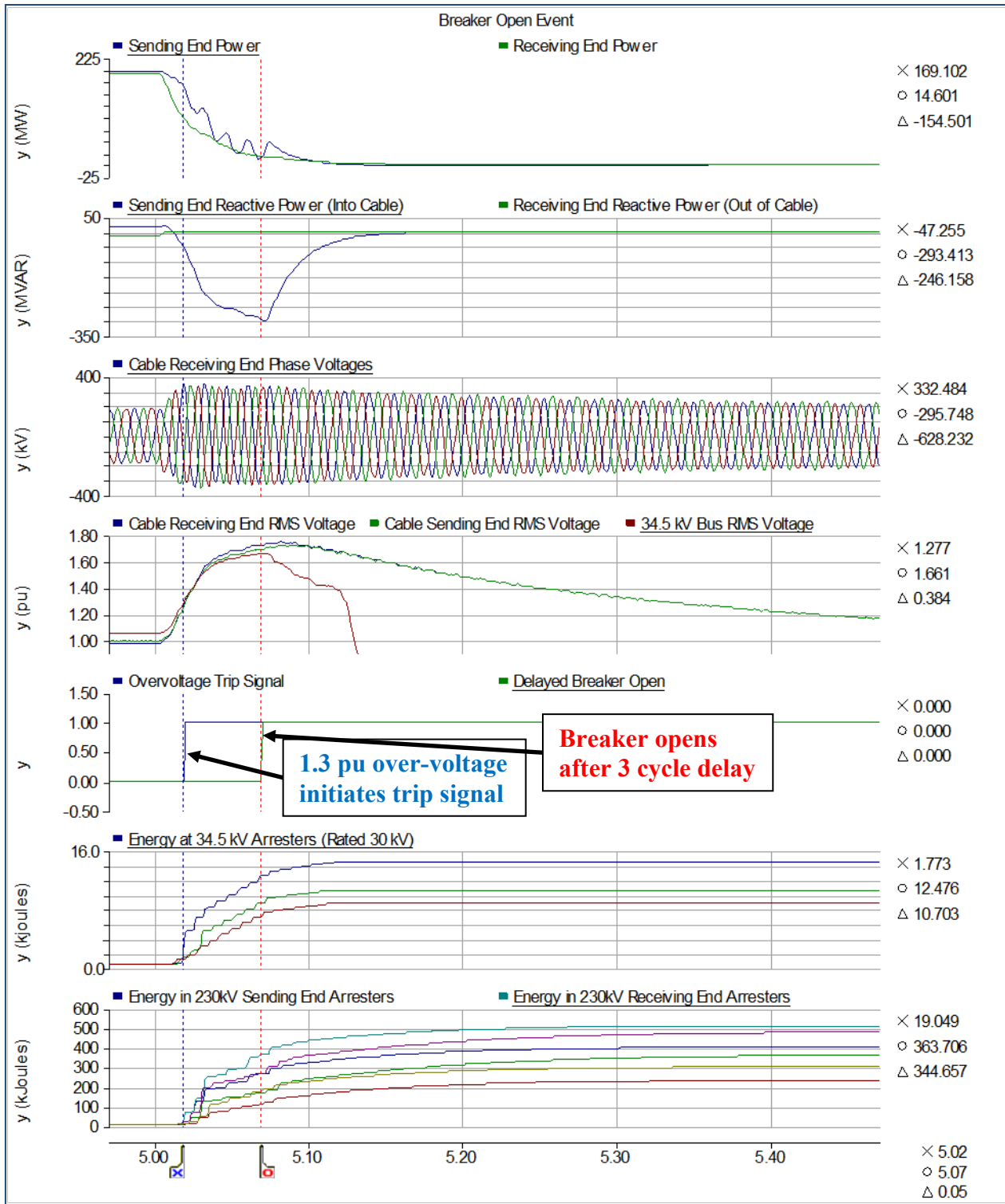

Figure B-4: Traces showing a POI breaker fail event isolating a radial 70 mile cable with a 200 MW wind farm consisting of DFIG (Type 3) turbines.

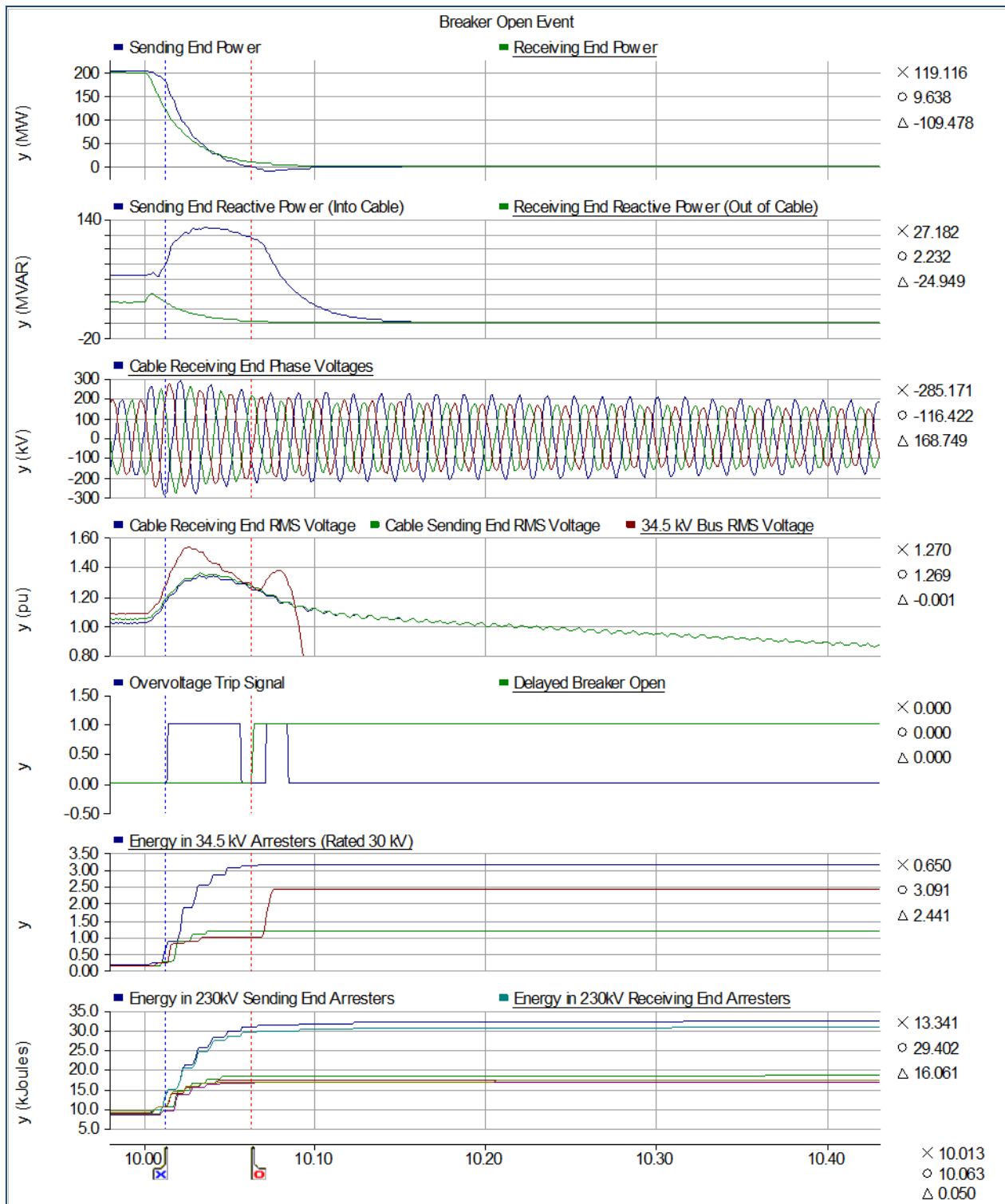

Figure B-5: Traces showing a POI breaker fail event isolating a radial 70 mile cable with a 200 MW wind farm consisting of Full Converter (Type 4) turbines.

## Conclusions

The most severe case of AC cable overvoltage occurs when the cable opens first at the receiving (Oahu) end. The sending end wind turbine generators at Lanai or Molokai continue to pump energy into the cable causing its AC voltage to rise quickly. The overvoltage protection on each wind turbine generator (normally set to trip at about 1.2 to 1.25 per unit) immediately causes each unit to trip, but because of switching and latency delays, may result in the AC overvoltage to continue to rise until restrained by the surge arresters. When a three cycle (50 msec) delay is imposed before the actual trip occurs, particularly for the DFIG units, the energy absorbed by the surge arresters is well within their capability. This amounts to 0.5 kJoule/kV for the 34.5-kV bus arresters and 2.6 kJoule/kV for the 230-kV bus sending end and receiving end arresters for the worst case DFIG units. Such arresters are normally rated 5 to 13 kJoule/kV.

As soon as the trip signal is sent by the receiving end (Oahu) protection to trip the receiving end 230 kV cable end circuit breaker, that signal is simultaneously sent by fiber to the sending end 230-kV cable end circuit breaker for a cross-trip (see Figure 2). The delay in the sending end 230-kV cable end breaker opening compared to the receiving end breaker opening is just the latency of telecommunication through the fiber to its trip circuit. This may be within half a cycle (8.3 msec) instead of the three cycles (50 msec) considered in the above analysis. Each wind turbine will also trip on overvoltage as a back-up if the cross-trip from Oahu fails.

For the responses observed in this study with worst case results summarized above, it is not necessary to have an SVC or STATCOM for dynamic voltage control at the sending end system unless required only for the wind turbine generators. The 100% compensation of the AC cable means that there is minimum reactive power swing since cable charging is fully compensated. It is therefore only the relatively low series impedance of the cable that causes reactive power variations with load. With the AC cable energized only from Oahu, the 100% compensation also allows for use of pre-insertion resistance using a resistor and two 230-kV breakers so that the energization is virtually voltage transient free on the Oahu 230-kV busbar. This alleviates the need for an SVC or STATCOM at Oahu.

There are other issues that appear manageable such as harmonic resonances on the cable. The application of an SVC or STATCOM will not solve these issues and so have little impact on the recommendation to not require them.

## APPENDIX C

### *Simulation Studies for Inter-Island DC Cable Options*

Updated May 2010

#### **Introduction**

A detailed simulation model of the Hawaiian Electric Power Company (HECO) electric network was developed in three phase representation on PSCAD<sup>11</sup>. The network of generators, transmission lines, transformers and loads was translated directly from the PSS/E<sup>12</sup> model developed by EPS. The DC cable transmission options outlined in Appendix A were added.

#### **Description of HVDC Cable Models**

Each HVDC converter station was modeled as a two level voltage sourced converter (VSC) with pulse width modulation switching at 900 Hz. For a 200 MW set of cables, the VSC converter at each end was configured as a symmetrical monopole as shown in Figure C-1. Two  $\pm 150$  kV, 667-Amp HVDC cables are provided with each converter.

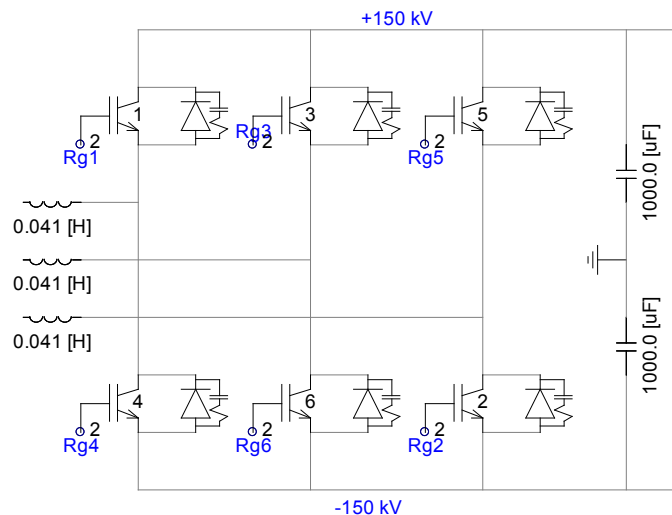

Figure C-1: PSCAD model of a 2 level symmetrical monopole 200-MW VSC converter

<sup>11</sup> PSCAD is an licensed electromagnetic transients program from Manitoba Hydro: <https://pscad.com/products/pscad/>:

<sup>12</sup> PSS/E is a licensed power system simulation of Siemens PTI.

For a 400 MW bipole consisting of two independent two level VSC poles, a bipolar configuration was applied as shown in Figure C-2. Here three cables are applied, two at 150 kV, 1,333 Amps, and the third as a metallic return rated at 50 kV and also 1,333 Amps.

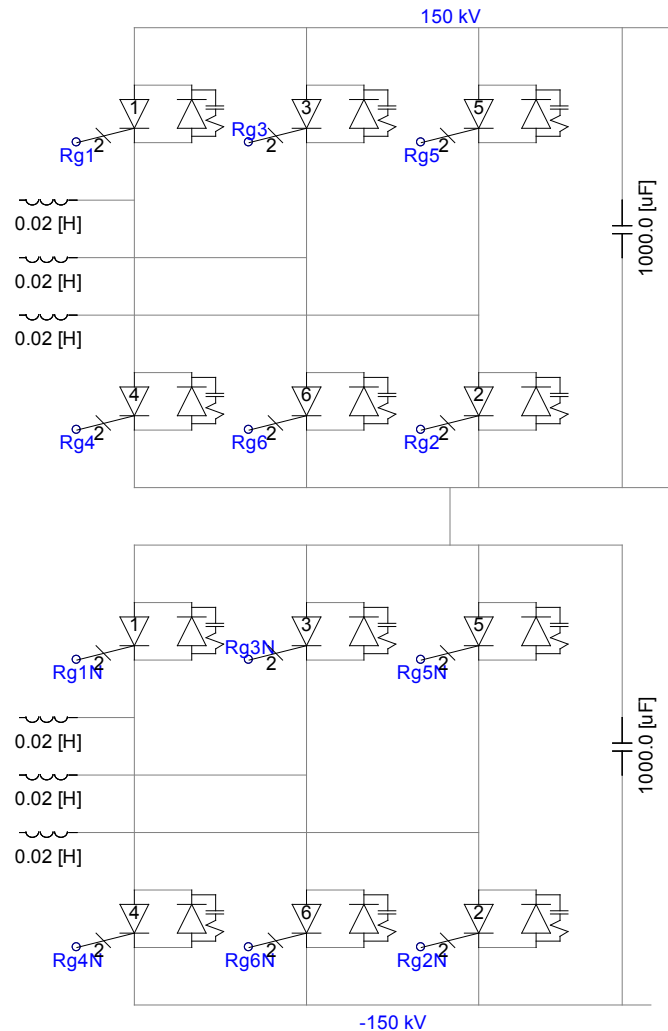

Figure C-2: PSCAD model of a 400-MW bipolar with 2 level VSC converter poles

The cables themselves were modeled based on the solid insulation cables of HVDC Light<sup>13</sup>. For the 200-MW symmetrical monopole, each cable with a 667-Amp conductor was 500 mm<sup>2</sup> and for the 400-MW bipole of 1,333 Amps, 1,600 mm<sup>2</sup>. It was assumed each cable was laid apart so that there was negligible magnetic coupling between them and to benefit from higher rating due to reduced thermal coupling. However, from an environmental aspect, dc magnetic field cancellation with the cables laid together may be required, which will necessitate a higher rated cable to compensate for the increased thermal coupling. Figure C-3 shows the dimensions of the 150-kV HVDC cables modeled, assuming each is buried 1 meter in the

<sup>13</sup> HVDC Light is a registered trademark of ABB.

seabed. Actual burial depths may be quite different depending on permits, but for studies the 1 meter is representative and variations to this depth have little impact on the transient performance of the cables required for this technical study.

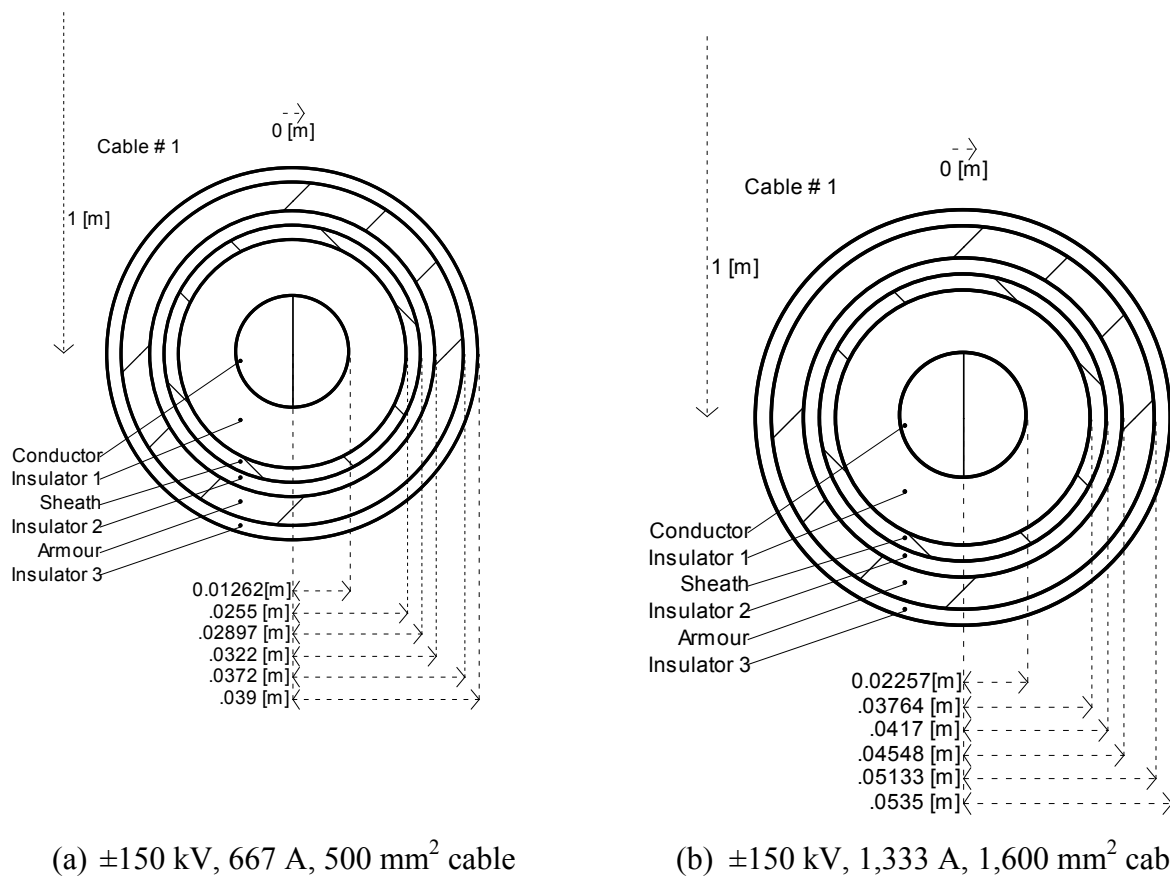

Figure C-3: HVDC cables modeled as individual co-axial cables

The bipolar cables are connected with a metallic return conductor that is grounded at one end. For the purpose of simulation, the metallic return conductor is the same as the main pole conductor cables. This is the traditional way for configuring a metallic return conductor so that no dc current ever flows in the sea and seabed. The single ground point at one end of the metallic return conductor is necessary to ground the VSC cable system, but it will not be a path for return current through the sea and seabed if the bipole is forced to operate as a single pole when the other pole is faulted and taken out of operation. The conductor rating of the metallic return conductor must be the same as the main pole conductors, but because it is grounded at one end, its electrical insulation is less than that of a pole conductor.

The controls for each pole or symmetrical monopole are separate and independent from any other pole or monopole. This is so each pole of 200 MW is the largest outage that a single

component failure can produce and is the maximum outage that is applied in this study. The controls for the VSC converters are based on generic strategies. The firing pulses to the valves shown in Figures C-1 and C-2 are generated for pulse width modulation at 900 Hz. Acceptable power quality is achieved with a supplementary high pass filter tuned at 900 Hz as shown in Figure C-4 that is positioned between the VSC converter and the connection transformer.

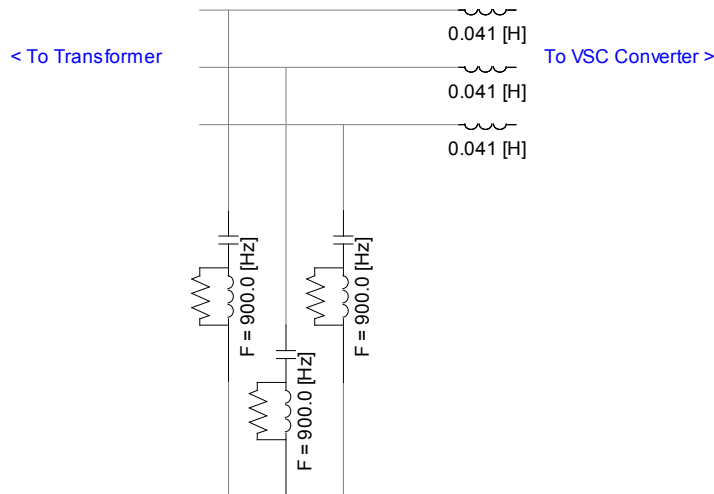

Figure C-4: Supplementary high pass harmonic filter with each VSC converter pole

There are a number of options for configuring the controls of the VSC converters at the wind farm end. What proved to be most effective was to lock the valve firing oscillator to generate 60-Hz alternating voltage. The ac voltage magnitude generated by the VSC converter at the wind farm (sending end) is controlled to provide the wind turbine generators with a stiff system to operate into. VSC converters produce the stiff system by creating what is designated as “effective short circuit capacity.” It is not the real short circuit capacity that synchronous generators or motors provide to the ac system as evident by the significant short circuit current they contribute. When a short circuit is applied at or near the terminals of a voltage sourced converter, it will either block so that it contributes no fault current whatsoever, or its current control limits the short circuit current to be equal or less than the rated current of the VSC. Most wind turbine generators on the market today are designed for connection to a grid which has adequate short circuit capacity for their operation. The strategy of locking the valve firing oscillator to 60 Hz and controlling ac voltage provides the necessary short circuit capacity, allowing connection of most types of wind turbine generators in the wind farm.

The independent clock control that locks the 60-HZ frequency at the sending end of the VSC cable in effect allows the converter to be like an AC swing generator/motor with infinite inertia. It will absorb any power from the wind farms and send it to Oahu or if no wind is blowing and the local load on the island needs power, it will generate exactly what the load requires, bringing the power from Oahu. It is not unlike having the Oahu terminating AC busbar right on the island so that the local load and wind turbines are completely served by the Oahu busbar. The disadvantage of this control is that over-current in the VSC converters are not so readily controlled.

Any power ramps up or down due to fluctuations in wind will be automatically transmitted to Oahu with independent clock control on the VSC converters. This study has not looked at the impact of such fluctuations of power on the Oahu electric power system.

The VSC converter connected to the HECO grid controls the dc voltage applied to the DC cables. The VSC converter also controls the reactive power it supplies to or takes from the AC system. In this way the AC voltage at the 138-kV interconnection busbars are controlled by the HECO facilities such as nearby generators and switched capacitor banks.

Alternatively, AC voltage on the HECO system at the connection busbar can be controlled.

### **Wind Turbine Generator Models**

Two types of generic but detailed wind turbine generator models are used for the wind farms on Molokai and Lanai. One is a doubly fed induction generator (DFIG) that is also known as a Class 3 model. GE, Vestas and Mitsubishi make DFIG units available. The other is a full converter model (FC) that is also known as a Class 4 model. Siemens and Enercon make FC units available. Both classes are used in the cases modeled in the expectation that the wind farms may consist of both types from various manufacturers.

The detail of these Class 3 and 4 wind turbine generators includes the following:

1. Pitch controller
2. Back to back converters
3. Vector controls for the back-to-back converters to separate real power and reactive power control



4. Detailed rotating machine models
5. Protections for overspeed and overvoltage

### Assessment of Performance of DC Cable Transmission

The performance of the options for DC cable transmission is measured by evaluating their responses of various disturbances and faults. The HECO grid must survive in terms of maintaining acceptable AC voltage and frequency, and maintain angle stability between the generators. The DC voltage and current in the VSC converters and undersea cables must remain within ratings, and the connection provided for the wind farms on Molokai and Lanai must also maintain acceptable levels of AC voltage and frequency.

#### Most Severe Single Contingency Disturbance

The most severe single contingency disturbance is an AC bus fault at the terminating interconnection busbar of the DC cable transmission, with delayed clearing which results in a 200-MW pole or monopole being disconnected as shown in Figure C-5.

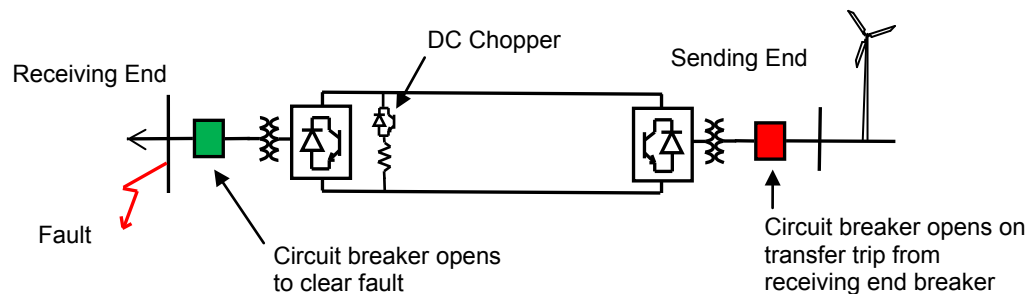

Figure C-5: Opening the DC cable at the point of interconnection to the AC grid

This fault being a bus fault at Iwilei or Koolau has a severe impact on the HECO grid. (The landing sites on the islands are simplifying assumptions for comparison purposes and should not be taken as the actual landing sites that will be used as several are being considered and evaluated in other study efforts). The power from the wind turbine will continue flowing into the cable through the converter at the sending (wind farm) end, causing the voltage on the DC cable to rise. Ideally the sending end circuit breaker could be transfer tripped by the same protection signal that was sent to the receiving end circuit breaker through a high speed fiber optic communication circuit. Since signal delays or failures need to be designed for, protection against overvoltage on the DC cable is achieved by a supplementary DC chopper

circuit as shown in Figure C-6. The DC chopper is a resistor that is switched in and out across the receiving end of the cable with a solid state switch. It can switch very quickly on detection of overvoltage building up on the DC cable. However, the DC chopper cannot operate indefinitely, and so the wind turbine generators will have to be disconnected from feeding into the DC cable by a secondary protection circuit if the primary transfer trip is delayed or fails.

This fault is represented in simulation with DC Option B1-2 which has a 200-MW monopole from Molokai and a 200-MW monopole from Lanai with both terminating at Iwilei. The wind farms on each island are operating at their full 200 MW rating. Figure C-6 shows the simulated results with the key to these specific time based plots and others as follows:

#### AC Volts on Oahu

VIwilei: 138 kV AC rms volts in per unit (pu) at Iwilei bus 130

VKoolau: 138 kV AC rms volts in per unit (pu) at Koolau bus 150

#### Generator rotor angles

Ang-AES: AES-1 unit at bus 1331

Ang-Wai: WAI-5 unit at bus 1205

Ang-Kahe6: KAHE-6 unit at bus 1146

#### AC Volts at Wind Farms on Molokai and Lanai

VMolokai: 33 kV AC rms bus volts in per unit (pu) at the Molokai wind farm

VLanai: 33 kV AC rms bus volts in per unit (pu) at the Lanai wind farm

#### Frequency on Oahu and at the Wind Farms on Molokai and Lanai

FIwilei: Frequency of HECO's system measured at Iwilei in Hz

FMolokai: Frequency of the Molokai wind farm in Hz

FLanai: Frequency of the Lanai wind farm in Hz

#### Power in DC poles

Power Pole 1: DC Power in one pole in MW

Power Pole 2: DC Power in the other pole in MW

#### Voltage on DC cables when one 400 MW bipole

VcableP: DC volts on positive pole cable in kV

VcableN: DC volts on negative pole cable in kV

#### Voltage on DC cables when two 200 MW symmetrical monopoles

VpMolokai: DC volts on positive polarity cable of monopole from Molokai in kV  
 VnMolokai: DC volts on negative polarity cable of monopole from Molokai in kV  
 VpLanai: DC volts on positive polarity cable of monopole from Lanai in kV  
 VnLanai: DC volts on negative polarity cable of monopole from Lanai

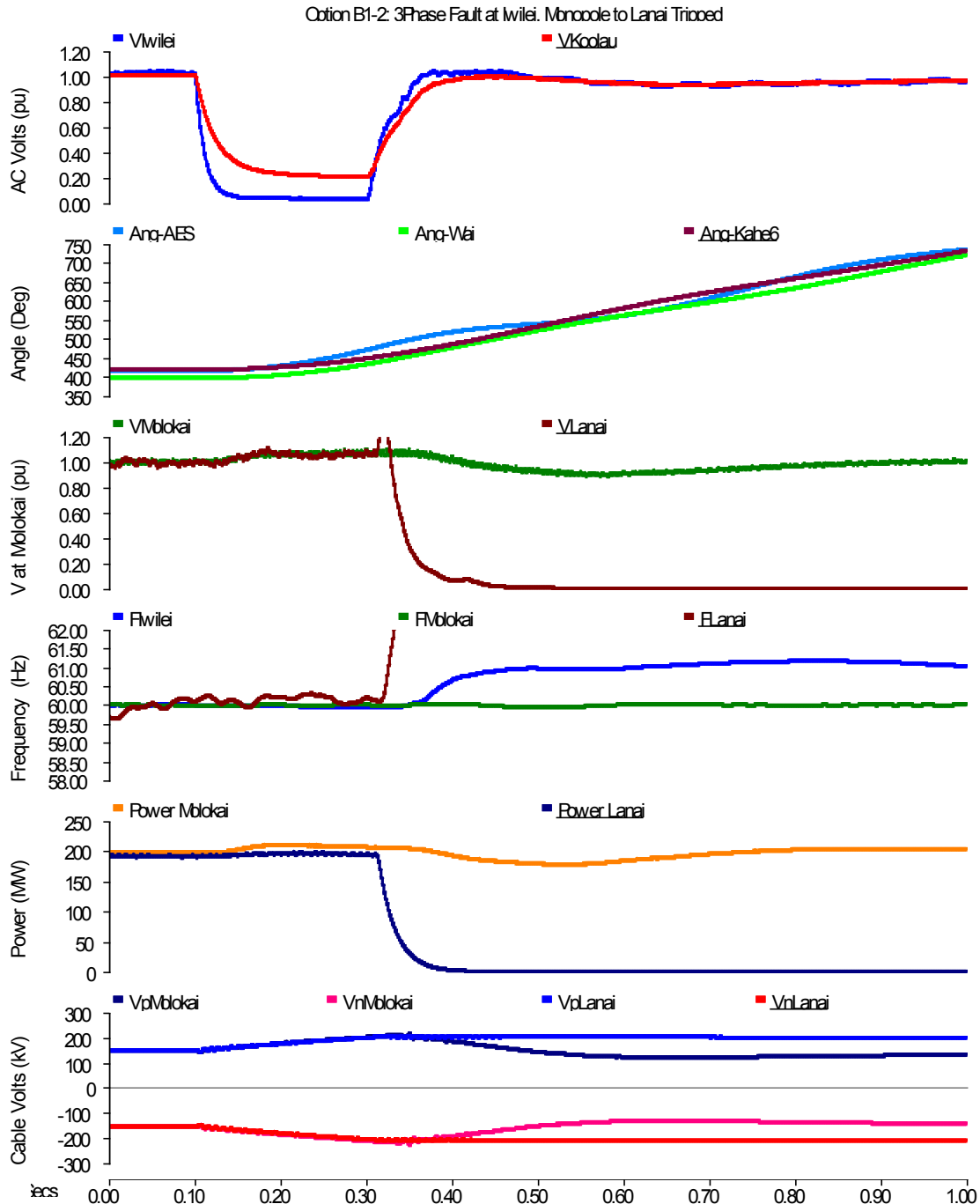

Figure C-6: DC Cable Option B1-2, a 200-MW monopole from Molokai and also from Lanai both terminating at Iwilei. 12 cycle, 3-phase bus fault at Iwilei causes monopole from Lanai to trip out of service. DC chopper not in service

There are several significant results that are shown here in Figure C-6, which highlight the seriousness of this severe receiving end fault:

1. While the fault is on and waiting to be cleared, the power generated at the two wind farms on Molokai and Lanai still feed power into the cables. In this case there is no indication at the wind farms at the sending end of the DC cables that there is a fault. The DC voltages on the cables commence to increase during the course of the fault. The DC chopper is not in service so the overvoltage on the DC cables can be observed. The DC voltage approached 1.5 per unit. The DC cable and converters should be capable of withstanding this level of overvoltage. Both the DC cable and converters will be designed to withstand a 2.0 per unit temporary overvoltage that will result from a DC cable fault. However, if this fault takes longer to clear, then there is a possibility that the DC overvoltage would be greater than 2.0 per unit without the DC chopper.
2. The fault is cleared after 12 cycles (0.2 seconds) which in this case causes the monopole from Lanai to trip out of service. The circuit breaker to the converter on Lanai is transfer tripped from Lanai with the protection signal that trips the receiving end circuit breaker being transmitted to Lanai through a fiber channel. The firing pulses to the converters at each end of the tripped monopole to Lanai are also blocked so that the DC cable and converters are taken from service. However, the DC cable and converters remain charged in excess of rated  $\pm 150$  kV.
3. When the monopole to Lanai is tripped and blocked, AC frequency control at Lanai is lost, and the wind turbine generators will require their protections to operate and take the wind farm off-line.
4. After the three-phase fault is cleared at Iwilei, the DC monopole to Molokai remains in service and recovers to its pre-disturbance power level. The HECO grid has cleared a severe AC fault at Iwilei, its generators remain synchronized but swinging, and has lost the 200-MW infeed from Lanai. This simulation shows the transient post disturbance AC voltage that occurs which suffers a transient dip down to about 0.92 per unit. The post disturbance grid frequency on the HECO system reaches 61 Hz based on this model.

### ***Impact of the DC Chopper***

The same disturbance of a 12 cycle three phase fault at Iwilei with 200-MW DC monopoles from Molokai and Lanai but with the DC chopper active is shown in Figure C-7 just for the DC cable voltages. Note that the DC chopper switches on the DC monopoles at approximately 0.24 and 0.31 seconds. When it switches off after the fault has cleared, there is some residual voltage ringing on the cable due to oscillations defined by the cable impedance, the DC side surge (smoothing) inductor and the VSC converter capacitance. The DC temporary overvoltage is limited to less than 1.5 pu compared with the nearly 2.0 pu with no DC chopper.

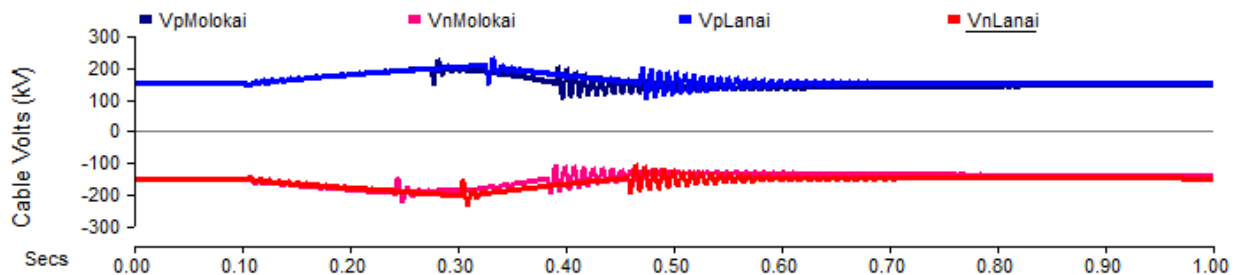

Figure C-7: DC Cable Option B1-2, 12 cycle, 3 phase bus fault at Iwilei causes monopole from Lanai to trip out of service, DC chopper operating limiting DC overvoltage to 1.47 pu

If the DC Cable transmission of 200-MW symmetrical monopoles each from Molokai and Lanai both terminate into Koolau as in Case C1-2, and the three phase, 12 cycle AC fault is applied to the 138-kV terminating AC busbar at Koolau, then the system performance is shown in Figure C-8. Similarly to the case shown in Figures C-6 and C-7, the AC bus fault causes the symmetrical monopole from Lanai to be disconnected at the receiving end leaving only the DC Cable from Molokai in service. The DC chopper is in-service and functioning for the simulation shown in Figure C-8. The same key to understanding the graphs applies.

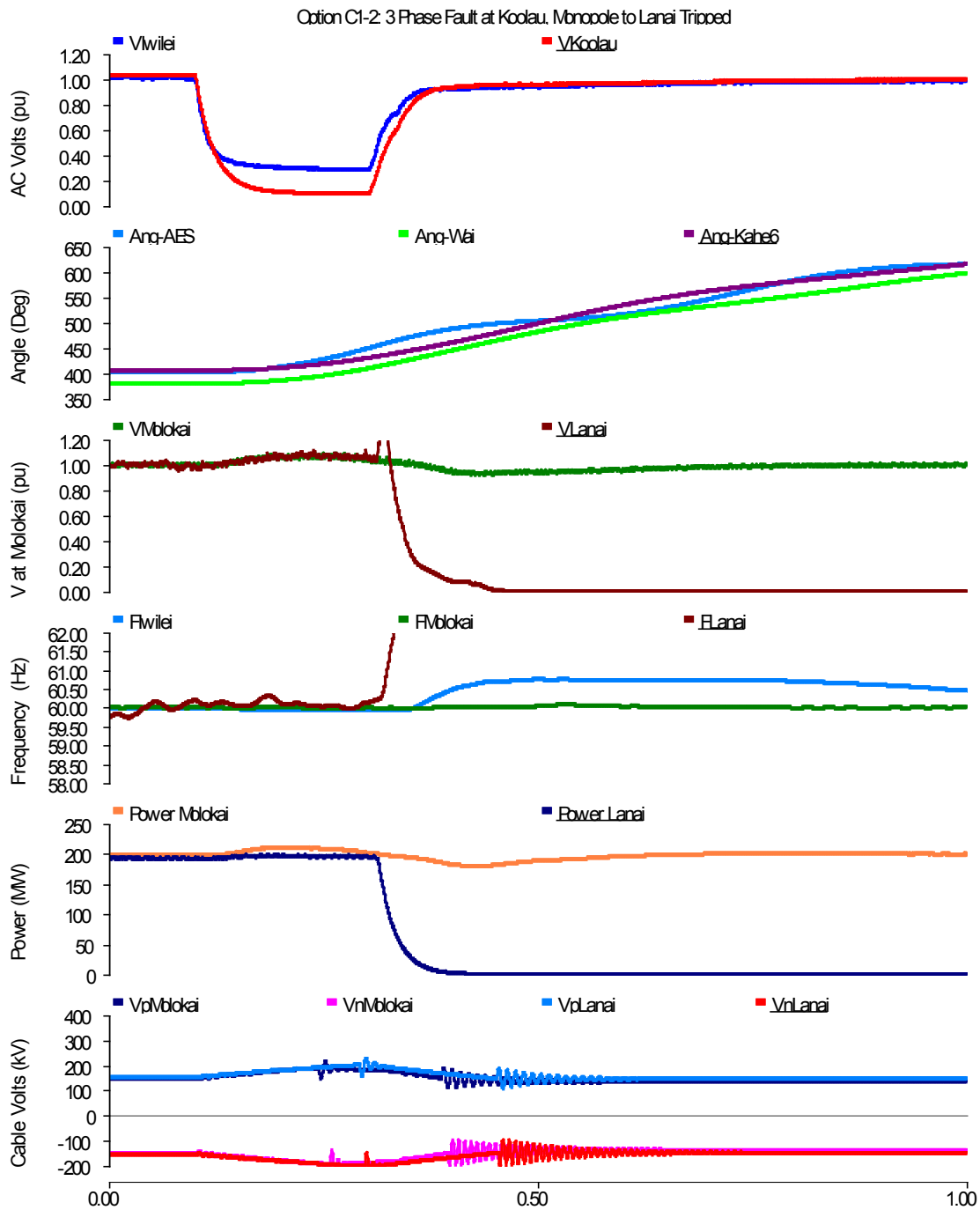

Figure C-8: DC Cable Option C1-2, 12-cycle, 3-phase bus fault at Iwilei causes monopole from Lanai to trip out of service. Monopole from Molokai remains operational. DC chopper in service

### Severe Disturbance with a Bipolar DC Cable

A similar problem results when the DC cable transmission to the HECO grid system is through a 400-MW bipole. The power through the remaining pole may recover to twice its rating as shown in Figure C-9.

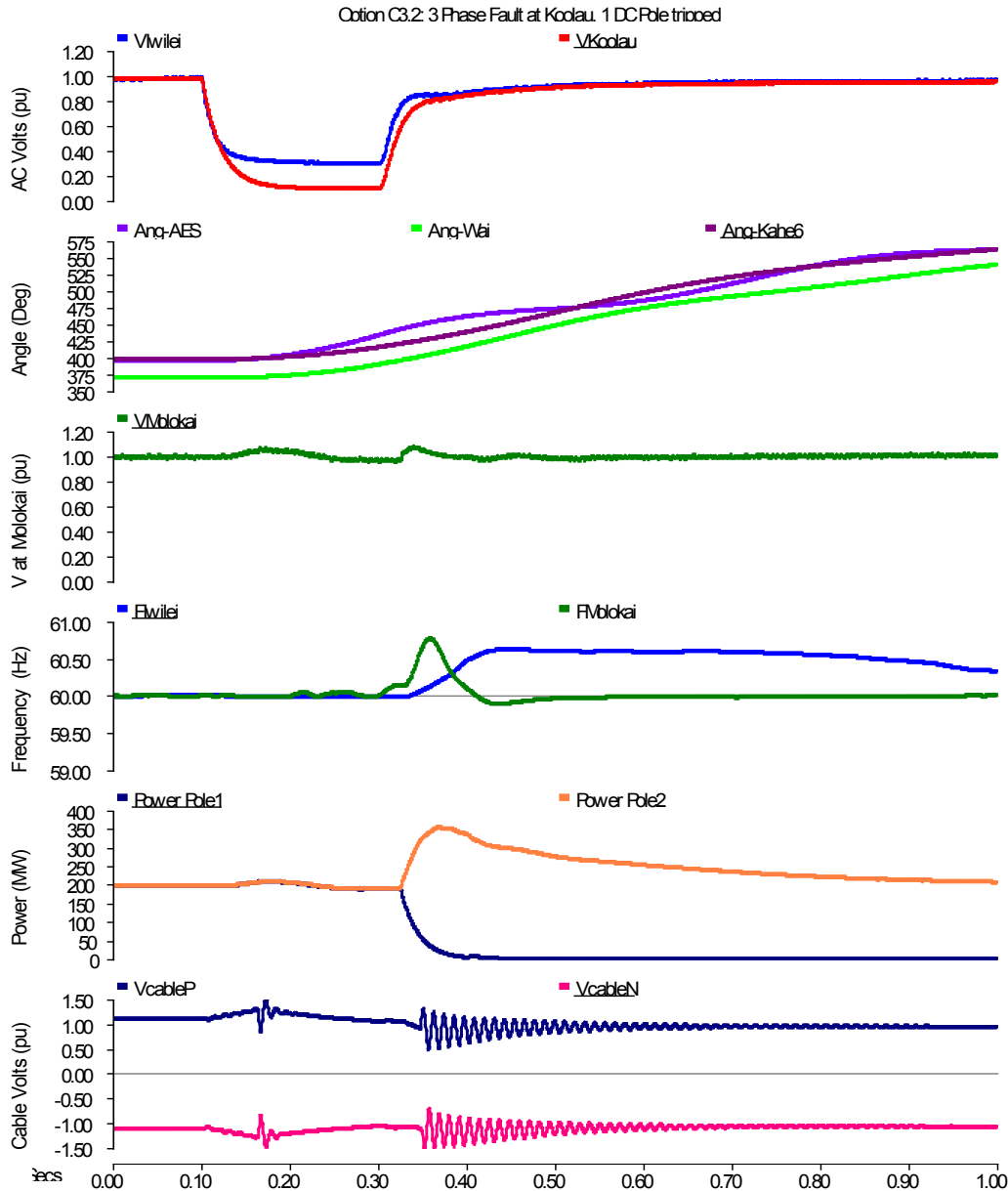

Figure C-9: DC Cable Option C3-2: With a 400-MW bipole from Molokai to Koolau, and a three phase fault at Koolau tripping one pole from service. Power order reduction applied to the wind farm to bring total wind farm generated power to within the rating of the pole remaining in service.

The sending end wind farm could be either on Molokai or Lanai and would be rated for 400 MW. It is necessary that each pole to be located on the AC terminating busbar so that no one busbar fault could remove both poles permanently from service. Therefore a busbar fault at

the terminating busbar would only remove one pole from continued operation. The very short thermal inertia of the valves in a VSC converter would normally not accommodate such an overload to the remaining pole in service as shown in Figure C-9. The options to deal with this are:

1. Purchase the VSC converters with enough rating to accommodate the overload.
2. Require that the wind turbine generators that connect to the sending end of the bipole have a power order controller. When the wind farm receives a signal that one pole is removed from service for one reason or another, the power order controller would reduce the total power from the wind turbine generators to a level that could be accommodated by the remaining pole of the DC Cable transmission. Such a function has been provided in the Horns Rev wind farm in the North Sea off the coast of Denmark where the wind turbine generators are DFIG units. The speed of the power down would have to be specified to occur within the rating capabilities of the pole left in service. The plot of Figure C-9 shows how such a power down might apply. However there is still a power overshoot for the operating pole for which it would need to be rated for.
3. Apply a transfer trip of wind turbine generator units at the wind farm. When the protection system for the DC Cable transmission detects that a pole is to be tripped from operation, wind turbine generators are immediately transfer tripped so that no overload occurs on the remaining pole after it recovers from the initiating fault. This is shown in Figure C-10 where the 400-MW bipole is based on Option B3-2 which terminates at Iwilei for a 400-MW radial transmission from Molokai.



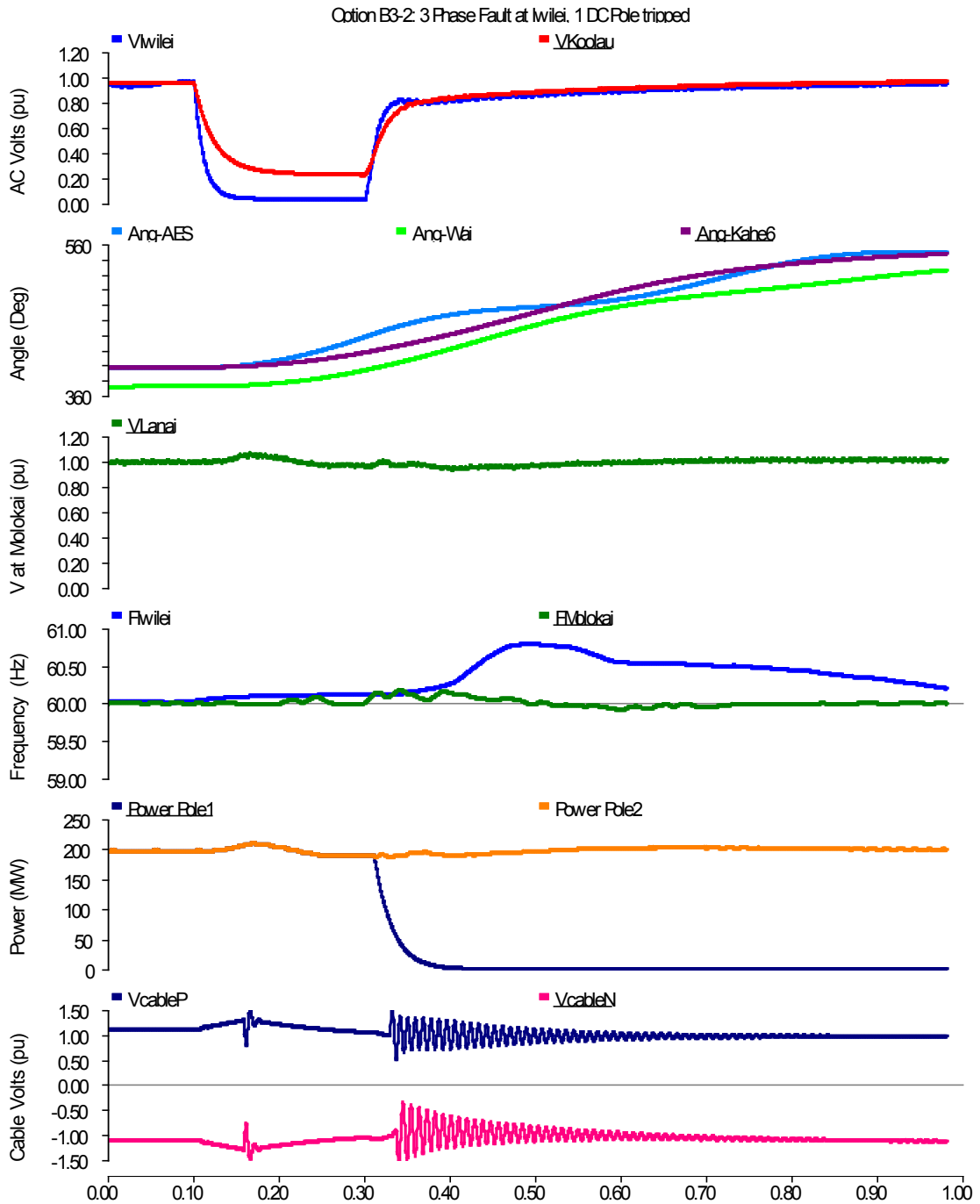

Figure C-10: DC Cable Option B3-2: With a 400-MW bipole from Molokai to Iwilei, and a three-phase fault at Iwilei tripping one pole from service. Transfer tripping of selected wind turbine generator units to bring total wind farm generated power to within the rating of the pole remaining in service.

***Impact of Faults on Oahu on Wind Turbine Generators on Molokai and Lanai***

If the DC Cable feeders to Oahu from Molokai and or Lanai remain in service through a system fault or disturbance on the HECO grid, then they have the ability to provide significant buffering to the wind turbine generators. This is because the voltage sourced converters are relatively impervious to AC side faults and disturbances. The DC cable voltage may increase during the fault or disturbance, but this is managed by the DC chopper as shown in Figures C-7 to C-10.

By way of example, the three-phase, 12-cycle fault is applied to the Koolau 138-kV AC bus for the configuration of Option A1-2. This case has a radial 200 MW symmetrical monopole from Iwilei to Lanai and a radial 200-MW symmetrical monopole from Koolau to Molokai. In addition, there is a 200-MW VSC transmission interconnection between Molokai and Lanai operating initially with a 20-MW power schedule from Molokai to Lanai. The response of the AC and DC system including the wind farms on Molokai and Lanai to this severe disturbance on Oahu is shown in Figure C-11. The following observations can be made:

1. The AC voltages on Molokai (VMolokai) and on Lanai (VLanai) are minimally impacted rising temporarily from near 1.0 pu to 1.06 pu during the fault and immediately after it is cleared. Then falling temporarily to 0.91 pu before recovering to 1.0 pu.
2. The frequencies on Molokai and Lanai during and after the fault at Koolau remain close to 60 Hz, whereas the frequency on Oahu increases to 60.8 Hz.
3. The power into the DC Cable transmission from the wind farms remains fairly constant through and after the fault at Koolau.

Consequently because the AC voltage and frequency that the wind farms on Molokai and Lanai are connected to stay relatively steady, the impact to the wind turbine generators on both islands is minimal for this severe AC fault at Koolau.

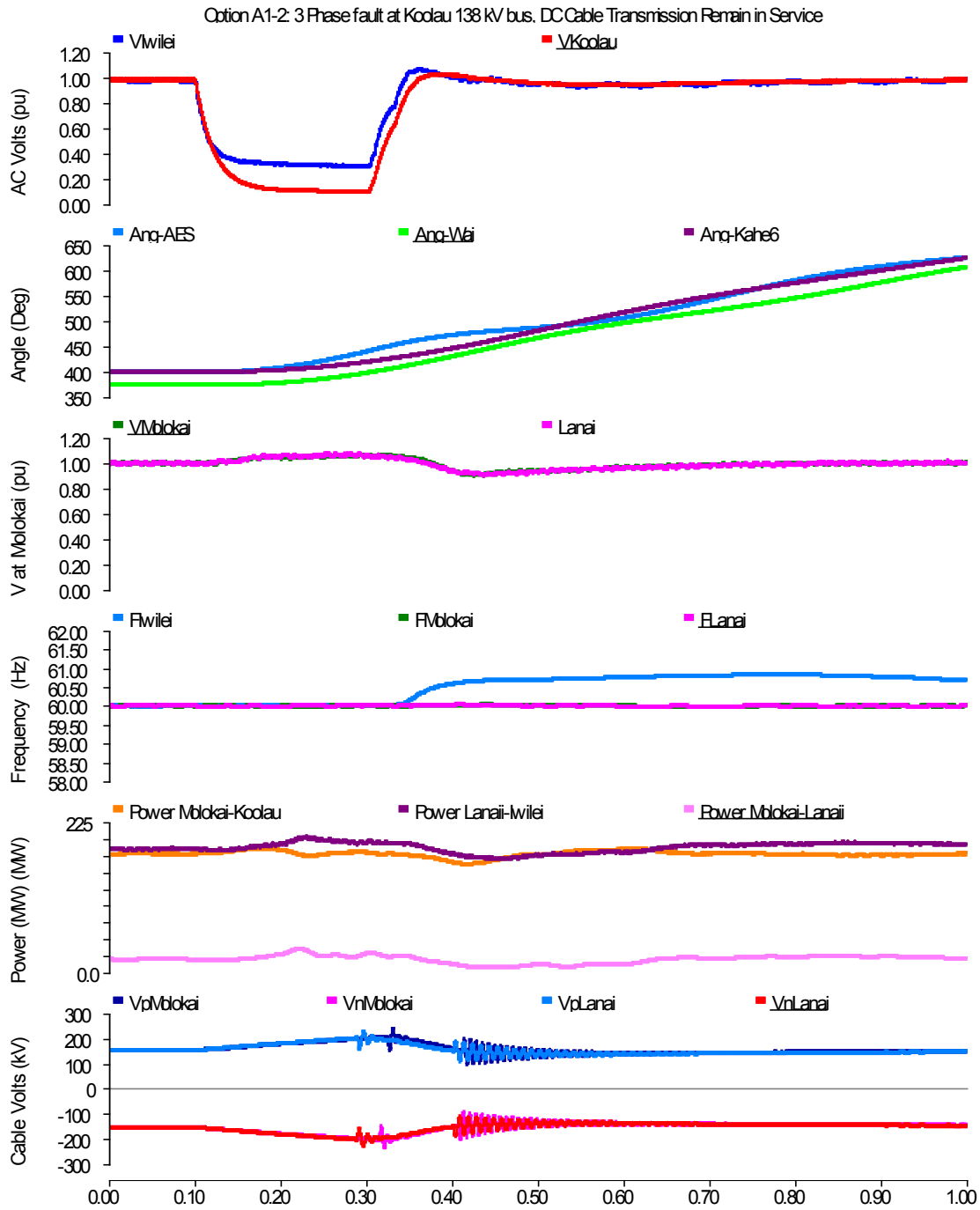

Figure C-11: DC Cable Option A1-2: With a 200-MW monopole from Molokai to Koolau, a 200 MW monopole from Lanai to Iwilei and a 200-MW monopole from Molokai to Lanai. A three phase fault for 12 cycles (0.2 seconds) is applied at Koolau with all DC Cable transmissions remaining operational.

***Impact of Faults on Molokai or Lanai on the HECO Grid on Oahu***

The consequence of severe AC system faults at Molokai or Lanai on the HECO grid on Oahu is also minimal due to the buffering properties of the VSC cable transmission. If the fault at a wind farm clears without significant loss of wind turbine generators, the impact at the receiving end will not be significant. If a large number of wind turbines trip because of the disturbance, then the loss of generation will reflect through to the HECO grid system which will have to adjust accordingly.

An interesting case for this disturbance is with DC Option A3-2 as shown in Figure C-12. 400 MW of wind turbine generation is located on the one island, which in this instance is Molokai. A 200-MW symmetrical monopole DC Cable feeds to Koolau from Molokai and another feeds to Iwilei from Molokai. A severe three phase AC fault is applied on a 33-kV wind farm collector circuit on Molokai that clears in 12 cycles (0.2 seconds) without loss of wind turbines.

The impact on the HECO grid is the AC voltage at both Koolau and Iwilei dips to 0.83 pu for the duration of the fault. DC cable voltage starts to fall and giving up power that feeds into the HECO grid system helping maintain its frequency. However after the fault is cleared and the Molokai AC voltage recovers, power is pumped into recovering the DC voltage to charge the cable and VSC capacitors at the expense of power being delivered into the HECO grid. At this point the frequency of the HECO grid commences to fall as a result of the temporary loss of delivered power as a consequence of the fault.

A control interaction of about 60 Hz occurs between the two VSC Cable transmission systems at Molokai. This is a control instability that slowly damps out. Closer inspection indicates that the DFIG wind turbine generators are included in the interaction but the FC units appear unaffected. The interaction has no significant impact on the delivery of power to the HECO grid system, but it has implications in coordinating the controls of the VSC Cable transmission lines and wind turbine generators. The contracts involving the connection of the VSC Cable transmission lines to the HECO grid and the interconnection agreements for connecting wind turbine generators to their sending end converters will require procedures and mechanisms in place to investigate and remedy such interactions if they are found to show up during design or operation.

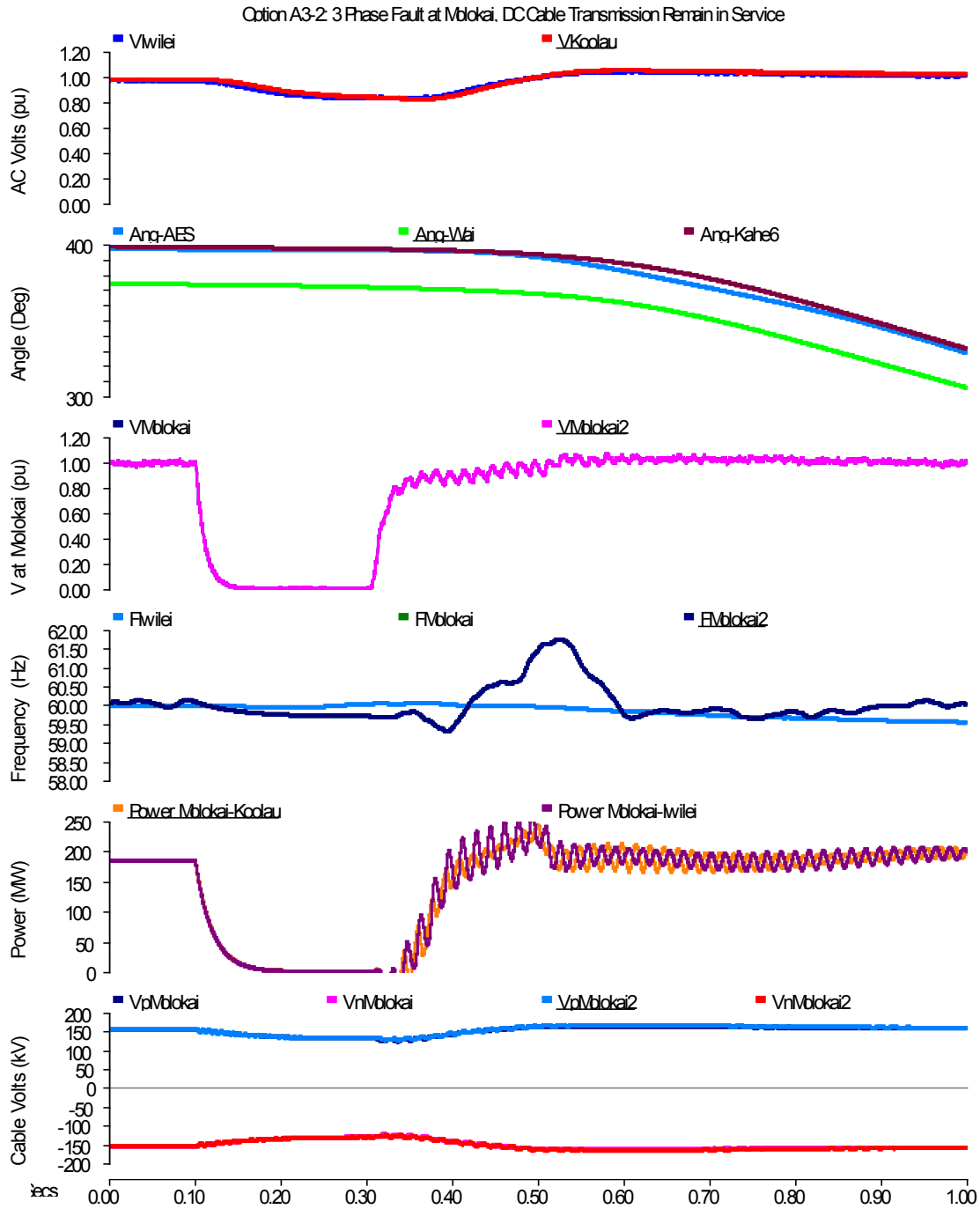

Figure C-12: DC Cable Option A3-2: With a 200-MW monopole from Molokai to Koolau and a 200-MW monopole from Molokai to Iwilei. A three-phase fault for 12 cycles (0.2 seconds) is applied at Molokai with all DC Cable transmissions remaining operational.

***Coordinating Design between the VSC Transmission and the Wind Turbine Generators***

Further to the control interaction observed in the study case of Figure C-12, there may not be much possibility for coordinated design of controls and protections between the wind turbine generators, the VSC transmission and the HECO grid. The proprietary nature of the controls of wind turbine generators and VSC transmission systems provides little opportunity for sharing of key designs between the various suppliers, particularly if they are competitors. The design of the VSC transmission controls and protections is the most important and this must be reflected in the technical specification required to establish a satisfactory contract with the DC equipment supplier. The technical specification must contain an acceptable performance requirement that the contracted DC equipment supplier must meet.

The performance standard for the controls, protection and rating design of the VSC transmission from the wind farms on the islands of Molokai and Lanai to Oahu must be robust and broadband enough to accommodate any type of modern wind turbine generator. A solid 60 Hz frequency and AC voltage must be provided for the wind turbine generators by the VSC transmission. The performance standard must ensure that the HECO grid is minimally impacted at the delivery points of the VSC transmission.

If done well, the VSC transmission will also act as a buffer from AC faults on Molokai and Lanai so the HECO grid system is minimally impacted.

## **APPENDIX D**

### ***Request for Information from DC Converter and Cable Manufacturers***

October 9, 2009, Updated November, 2009.

To:  
DC Converter Station Suppliers (ABB, Areva and Siemens)

#### **OAHU WIND INTEGRATION AND TRANSMISSION STUDY (OWITS) BUDGET PRICING OF INTER-ISLAND CABLE OPTIONS**

The US Department of Energy through the National Renewable Energy Laboratory (NREL) invites you to respond to this request for budget pricing information on various options for HVDC converter and AC substations terminating undersea electric power cable transmission from the Hawaiian Islands of Molokai, Lanai and Maui to Oahu.

#### **Return Information**

Please return the completed budget pricing form (pages 7 to 17 below) to:

National Renewable Energy Laboratory  
Attn: David Corbus,  
1617 Cole Boulevard  
Golden, CO 80401-3393  
USA

Email: [David.Corbus@nrel.gov](mailto:David.Corbus@nrel.gov)

By November 20, 2009.

#### **Confidentiality**

The information received from NREL through this request is confidential and must be treated as such. Likewise, the recipient of this request will not have their name or

association with the information submitted to NREL on the budget pricing form disclosed to anyone other than the team specifically assigned to evaluate this project.

## **Background to the Project**

The Hawaii Clean Energy Initiative (HCEI) is a multiyear initiative with the State of Hawaii with an objective to provide technical support to the State to meet a self-imposed goal of 70% clean energy use through renewables and efficiency in the electricity and transportation sector by the year 2030 (40% by renewables).

One of the driving forces for FY09/10 work is the signed agreement between the State and Hawaiian Electric Company (HECO), Inc. that includes a combined commitment of up to 100 MW of on-island wind resources and up to 400 MW of wind on the Islands of Lanai and Molokai via an inter-island cable that would bring that wind energy to Oahu.

To support the HCEI and HECO efforts, the Oahu Wind Integration and Transmission Study (OWITS) study has been initiated. The goal of OWITS is to help stakeholders, with special emphasis on the utility and the state, to understand the costs and operating impacts of significant amounts of wind power on their island grids and to help them identify the technical requirements of and configuration for an undersea inter-island cable to transmit electricity from large wind and or solar systems from one island to another island.

The HECO system on Oahu is today an island system without inter-ties to neighboring islands. With potential for at least 100 MW of on-island wind generation, the impacts of additional wind variability and transient impacts on grid reliability due to connecting neighbor island wind all need to be carefully considered.

HECO currently runs with a spinning reserve sufficient to cover the loss of the largest single generator connected to the system. The largest single generator currently on the HECO system is AES at 180 MW. As such, when AES is online the system is operated with a spinning reserve of approximately 180 MW. Given this spinning reserve requirement and the dynamic impact to the system, it can be assumed that the HECO system will not be able to withstand the instantaneous loss of all 400MW from the Lanai and Molokai wind plants and the cable system will need to be designed such that only 200 MW can be disconnected due to any single point of failure.

The HECO system has a limited ability to withstand the switching transients associated with the loss of any single compensation system. As such, the voltage transients associated with the switching or failure of reactive compensation for the AC system need to be evaluated and acceptable limit levels considered. In addition, a reactive power system to address any voltage support and control requirements on the submarine cables (i.e. minimum power flow of 0 MW to the total maximum power flow of 200 MW per circuit) will need to be addressed as part of a design conceptualization and configuration trade-off effort.



There is a number of cable routing possibilities from the islands of Molokai, Lanai and Maui to Oahu. One such possibility is shown in Figure 1. With up-to-date cable and termination pricing, it will be possible to select a preferred configuration for the interconnections. Both AC and HVDC options are under consideration. The HVDC options will be with Voltage Sourced Converters (VSC).

The connections from Molokai and Lanai to Oahu can be considered as a first stage development and can be scheduled to be placed in service in a practical sequence. The interconnection from Maui to Oahu is a second stage development and can be considered to be in service 5 years after stage 1 is fully operational.

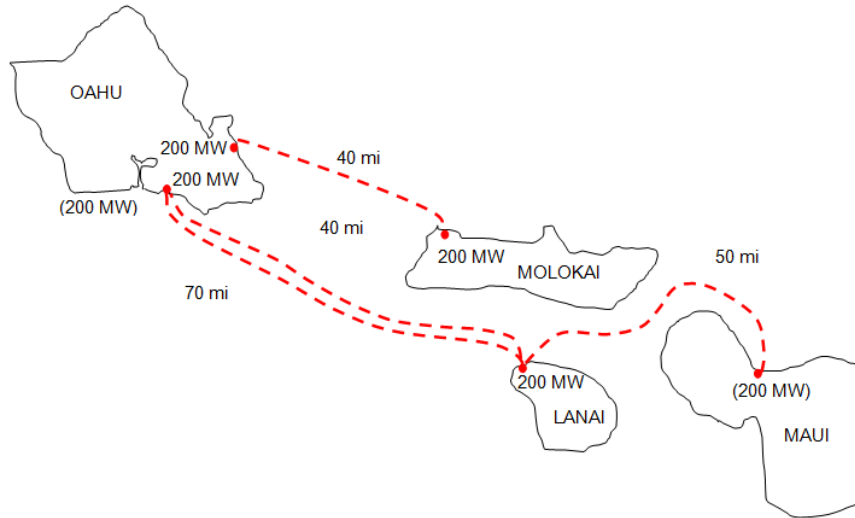

Figure 1: Possible cable interconnections between the Hawaiian Islands.

### **Budget Pricing Requirements**

Budget pricing is required for engineering, procurement and construction (EPC) of AC and HVDC stations. Spare transformers and AC shunt reactors are to be included in the terminal station prices along with inclusion of normally supplied spares for other equipment.

The budget prices are to be submitted as if they were being quoted for immediate installation of all stages, and are to be submitted in current US dollars.

Site licensing and preparation for terminal stations are not to be included in the budget prices submitted.

For the purpose of pricing, the AC systems on Molokai, Lanai and Maui will be wind farms consisting of various types of wind turbine generators consisting mainly of doubly fed induction generators (DFIG) and full converter (FC) units. The terminal stations must be able to support these generators with adequate AC voltage and frequency control.

The load on the receiving end of the interconnections on Oahu will be the HECO system.

## HVDC Converter Stations

Two VSC converter station options will be priced. These are:

DC-1: 200-MW symmetrical monopole.

DC-2: 400-MW bipole, so that each pole operates independent of the other pole, with both poles constructed at the same time.

DC-3: 400-MW bipole, so that each pole operates independent of the other pole, but with each pole constructed at different times. In other words, the pricing of a 200-MW pole will be separately provided with the consideration that they will be constructed separately.

Nominal DC voltage:  $\pm 150$  kV

### General Data for the AC systems

Table 1 Sending end systems at Molokai, Lanai and Maui

Nominal AC Voltage	138	kV	AC voltage to be controlled by VSC converter
Maximum continuous voltage	145	kV	
Minimum continuous voltage	131	kV	
Nominal frequency	60	Hz	AC frequency to be controlled by VSC converter
Short circuit capacity	?		As provided by wind turbine generators and VSC converter
Environmental conditions	Tropical		
Altitude	Near sea level		

Table 2: Receiving end HECO's system at Oahu

Nominal AC Voltage	138	kV	AC voltage control with droop characteristic or constant reactive power option
Maximum continuous voltage	145	kV	
Minimum continuous voltage	131	kV	
Nominal frequency	60 $\pm$ 0.5	Hz	Frequency controlled by HECO
Maximum short circuit capacity	5,000	MVA	
Minimum short circuit capacity	1,590	MVA	
Environmental conditions	Tropical		
Altitude	Near sea level		

## AC Terminal Stations

Budget pricing is required for the AC terminal stations based on an AC cable voltage of 230 kV. The components for a terminal substation are shown in the single line diagram of Figure 2. The cables are assumed to be shunt compensated at near 100%. The cable will be energized by a two breaker pre-insertion resistor scheme as shown in Figure 2.

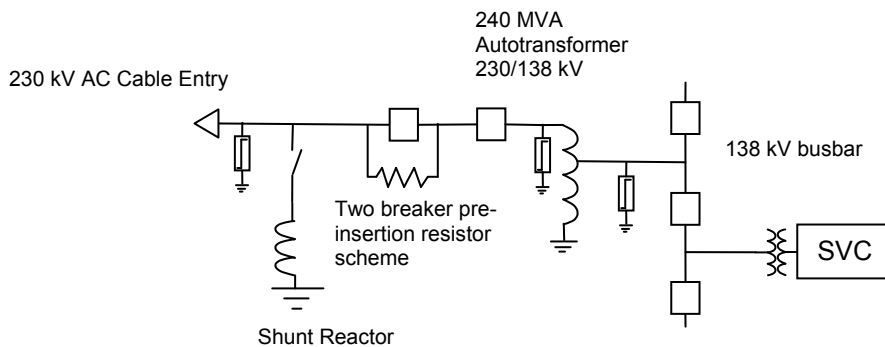

Figure 2: Single line diagram of an AC terminal substation at both sending and receiving ends of the AC Cable

Further study will be undertaken to finalize the configuration of the AC substations, which may impact sizing of the shunt reactors and SVC, as well as the winding configuration of the 230/138-kV transformer. However, for this budget pricing exercise, the layout in Figure 2 will be applied. The options for pricing the substations terminating the AC cable will vary according to the ratings of the shunt reactor and SVC. The options for pricing are presented in Table 3. Each reactor bank shall include a spare phase for rapid (within 2 days) insertion time.

Table 3: AC terminal substation pricing options

Substation Component	AC-1	AC-2	AC-3
230 kV Shunt Reactors	1-96 MVAR	1-120 MVAR	1-170 MVAR
SVC	±30 MVAR	±40 MVAR	±50 MVAR

The remaining components in the AC substation will remain the same for all three options and will include:

- 240 MVA autotransformer and spare phase/transformer
- 2 – 230 kV circuit breakers and disconnect switches
- 5 Mjoule, 230-kV pre-insertion resistor
- 3 – 138 kV-circuit breakers and disconnect switches
- 230-kV and 138-kV surge arresters

- Reactor switch
- 230-kV and 138-kV buswork
- Instrument transformers
- Protection systems

The pricing for the transformers, shunt reactors, pre-insertion resistor and SVCs to be separately identified for each AC option.

There is expected to be a space requirement for some substation locations under consideration and budget prices are requested for each of the three options both with air insulated substation (AIS) and gas insulated substation (GIS).

### **Cable Options**

The HVDC cables will be for operation with voltage sourced converters at  $\pm 150$  kV. AC cable options are being considered for 230 kV. Budget prices for the cable options are being requested separately.

---

**EQUIPMENT SUPPLIER'S NAME**

**Project: Oahu Wind Integration and Transmission Study (OWITS)**

**HVDC Converter and AC Substations**

**BUDGET PRICING FORM**

**PRICING**

Firm lump sum prices are to be provided for to all labor, materials, equipment, required spares, labor supervision, construction tools and equipment, construction services and utilities to design, furnish, erect and commission the HVDC converter station and AC substation options.

For the purpose of proposal evaluation the Equipment Supplier shall break down the estimated lump sum price for the three HVDC Voltage Sourced Converter Station options (considering one end only) as follows:

HVDC Converter Station Option DC-1: 200-MW symmetrical monopole.

1.	Basic Converter Station	\$ _____
2.	Recommended Spares Cost	\$ _____
3.	Duty, based on a _____ % rate	\$ _____
4.	Insurance	\$ _____
5.	Transportation	\$ _____
6.	Total	\$ _____

Operating Data for Option DC-1

7.	Largest single contingency loss (MW)	_____
8.	Inductive reactive power capability at full load (MVAR)	_____
9.	Capacitive reactive power capability at full load (MVAR)	_____
10.	45 minute overload rating of converter (MW)	_____
11.	Estimated converter station size (feet <sup>2</sup> )	_____

HVDC Converter Station Option DC-2: 400-MW bipole, so that each pole operates independent of the other pole, with both poles constructed at the same time.

1.	Basic Converter Station	\$ _____
2.	Recommended Spares Cost	\$ _____
3.	Duty, based on a _____ % rate	\$ _____
4.	Insurance	\$ _____
5.	Transportation	\$ _____
6.	Total	\$ _____

Operating Data for Option DC-1

7.	Largest single contingency loss (MW)	_____
8.	Inductive reactive power capability at full load (MVAR)	_____
9.	Capacitive reactive power capability at full load (MVAR)	_____
10.	45 minute overload rating of converter (MW)	_____
11.	Estimated converter station size (feet <sup>2</sup> )	_____

HVDC Converter Station Option DC-3: 400-MW bipole, so that each pole operates independent of the other pole, but with each pole constructed at different times. In other words, the pricing of a 200-MW pole will be separately provided with the consideration that they will be constructed separately.

1.	Basic Converter Station with pole 1 constructed	\$ _____
2.	Recommended Spares Cost	\$ _____
3.	Duty, based on a _____ % rate	\$ _____
4.	Insurance	\$ _____
5.	Transportation	\$ _____
6.	Total Pole 1	\$ _____
7.	Pole 2 as if separately and independently built	\$ _____
8.	Recommended Spares Cost	\$ _____
9.	Duty, based on a _____ % rate	\$ _____
10.	Insurance	\$ _____
11.	Transportation	\$ _____
12.	Total Pole 2	\$ _____

Operating Data for Option DC-3

13. Largest single contingency loss (MW) \_\_\_\_\_
14. Inductive reactive power capability at full load (MVAR) \_\_\_\_\_
15. Capacitive reactive power capability at full load (MVAR) \_\_\_\_\_
16. 45 minute overload rating of converter (MW) \_\_\_\_\_
11. Estimated converter station size (feet<sup>2</sup>) \_\_\_\_\_

AC AIS Substation Option AC-1a with 240-MVA, 230/138-kV transformer and spare  
1 – 96 MVAR, 230-kV shunt reactor and spare, 1 - ±30 MVAR, 138-kV SVC  
and 1-5MJ, 230-kV resistor with by-pass circuit breaker

1. 1 – 240-MVA, 230/138-kV transformer \$ \_\_\_\_\_
2. 1 – 96 -VAR, 230-kV shunt reactor \$ \_\_\_\_\_
3. 1 - ±30-MVAR, 138-kV SVC \$ \_\_\_\_\_
4. 230-kV, 5-MJ resistor and by-pass circuit breaker \$ \_\_\_\_\_
5. Remainder of Substation \$ \_\_\_\_\_
6. Recommended Spares Cost \$ \_\_\_\_\_
7. Duty, based on a \_\_\_\_\_ % rate \$ \_\_\_\_\_
8. Insurance \$ \_\_\_\_\_
9. Transportation \$ \_\_\_\_\_
10. Total \$ \_\_\_\_\_

Operating Data for Option Ac-1a

11. Estimated substation size (feet<sup>2</sup>) \_\_\_\_\_

AC AIS Substation Option AC-2a with 240-VA, 230/138-kV transformer and spare, 1  
– 120 MVAR, 230-kV shunt reactor and spare, 1 - ±40 MVAR, 138-kV SVC and 1-  
5-MJ, 230-kV resistor with by-pass circuit breaker

1. 1 – 240-MVA, 230/138-kV transformer \$ \_\_\_\_\_
2. 1 – 120-MVAR, 230-kV shunt reactor \$ \_\_\_\_\_
3. 1 - ±40-MVAR, 138-kV SVC \$ \_\_\_\_\_
4. 230-kV, 5-MJ resistor and by-pass circuit breaker \$ \_\_\_\_\_
5. Remainder of Substation \$ \_\_\_\_\_
6. Recommended Spares Cost \$ \_\_\_\_\_
7. Duty, based on a \_\_\_\_\_ % rate \$ \_\_\_\_\_

- 8. Insurance \$ \_\_\_\_\_
- 9. Transportation \$ \_\_\_\_\_
- 10. Total \$ \_\_\_\_\_

Operating Data for Option Ac-2a

- 11. Estimated substation size (feet<sup>2</sup>) \_\_\_\_\_

AC AIS Substation Option AC-3a with 240-MVA, 230/138-kV transformer and spare, 1 – 170 MVAR, 230-kV shunt reactor and spare, 1 - ±50 MVAR, 138 kV SVC and 1-5MJ, 230-kV resistor with by-pass circuit breaker.

- 1. 1 - 240 MVA, 230/138-kV transformer \$ \_\_\_\_\_
- 2. 1 – 96 MVAR, 230-kV shunt reactor \$ \_\_\_\_\_
- 3. 1 - ±50 MVAR, 138 kV SVC \$ \_\_\_\_\_
- 4. 230-kV, 5-MJ resistor and by-pass circuit breaker \$ \_\_\_\_\_
- 5. Remainder of Substation \$ \_\_\_\_\_
- 6. Recommended Spares Cost \$ \_\_\_\_\_
- 7. Duty, based on a \_\_\_\_\_ % rate \$ \_\_\_\_\_
- 8. Insurance \$ \_\_\_\_\_
- 9. Transportation \$ \_\_\_\_\_
- 10. Total \$ \_\_\_\_\_

Operating Data for Option Ac-3a

- 11. Estimated substation size (feet<sup>2</sup>) \_\_\_\_\_

The estimated lump sum price for three GIS HVAC Substation options (considering one end only) as follows:

AC GIS Substation Option AC-1b with 240 MVA, 230/138-kV transformer and spare 1 – 96 MVAR, 230-kV shunt reactor and spare, 1 - ±30 MVAR, 138-kV SVC and 1-5MJ, 230-kV resistor with by-pass circuit breaker

- 1. 1 - 240 MVA, 230/138-kV transformer \$ \_\_\_\_\_
- 2. 1 – 96 MVAR, 230-kV shunt reactor \$ \_\_\_\_\_
- 3. 1 - ±30 MVAR, 138-kV SVC \$ \_\_\_\_\_
- 4. 230-kV, 5-MJ resistor and by-pass circuit breaker \$ \_\_\_\_\_



5.	Remainder of Substation	\$ _____
6.	Recommended Spares Cost	\$ _____
7.	Duty, based on a _____ % rate	\$ _____
8.	Insurance	\$ _____
9.	Transportation	\$ _____
10.	Total	\$ _____

Operating Data for Option Ac-1b

11.	Estimated substation size (feet <sup>2</sup> )	_____
-----	--	-------

AC GIS Substation Option AC-2b with 240-MVA, 230/138-kV transformer and spare, 1 – 120 MVAR, 230-kV shunt reactor and spare, 1 - ±40 MVAR, 138-kV SVC and 1-5MJ, 230-kV resistor with by-pass circuit breaker

1.	1 - 240 MVA, 230/138-kV transformer	\$ _____
2.	1 – 120 MVAR, 230 kV-shunt reactor	\$ _____
3.	1 - ±40 MVAR, 138-kV SVC	\$ _____
4.	230-kV, 5-MJ resistor and by-pass circuit breaker	\$ _____
5.	Remainder of Substation	\$ _____
6.	Recommended Spares Cost	\$ _____
7.	Duty, based on a _____ % rate	\$ _____
8.	Insurance	\$ _____
9.	Transportation	\$ _____
10.	Total	\$ _____

Operating Data for Option Ac-2b

11.	Estimated substation size (feet <sup>2</sup> )	_____
-----	--	-------

AC GIS Substation Option AC-3c with 240-MVA, 230/138-kV transformer and spare, 1 – 170 MVAR, 230-kV shunt reactor and spare, 1 - ±50 MVAR, 13- kV SVC and 1-5MJ, 230-kV resistor with by-pass circuit breaker.

1.	1 - 240 MVA, 230/138-kV transformer	\$ _____
2.	1 – 96 MVAR, 230-kV shunt reactor	\$ _____
3.	1 - ±50 MVAR, 138-kV SVC	\$ _____

4.	230-kV, 5 MJ resistor and by-pass circuit breaker	\$ _____
5.	Remainder of Substation	\$ _____
6.	Recommended Spares Cost	\$ _____
7.	Duty, based on a _____% rate	\$ _____
8.	Insurance	\$ _____
9.	Transportation	\$ _____
10.	Total	\$ _____

Operating Data for Option Ac-3c

11.	Estimated substation size (feet <sup>2</sup> )	_____
-----	--	-------

**OFFER OF ALTERNATIVES**

The Equipment Supplier shall provide budget prices on the work exactly as requested. However, the Equipment Supplier is invited to offer alternatives. If an alternative is offered, the Equipment Supplier shall state clearly in what way the work differs from what has been requested, why such alternative work is offered and how, in the Equipment Supplier's opinion, the alternative configuration and product features would better suit the operational environment of an islanded system. The prices for alternative work shall be set out in the same manner as for the work specified.

**DELIVERY TIMES**

The Equipment Supplier shall provide the delivery times from receipt of order until the HVDC converter stations or AC substations are brought into commercial operation.

**EVIDENCE OF EQUIPMENT SUPPLIER'S ABILITY, EXPERIENCE AND PLANT**

The Equipment Supplier is invited to provide evidence of ability and experience to supply the HVDC Converter stations and AC substations as requested. In particular experience with undersea cable systems and wind farms should be highlighted. The Equipment supplier shall include experience in providing HVDC and HVAC

transmission as a sole radial feeder for wind turbines, their ratings, year of installation, Owner's contact name, phone number and email address.

## WARRANTIES

The Equipment Supplier is invited to provide a written description of the performance and equipment warranties that would be offered, including budget prices.

## OPERATION & MAINTENANCE SERVICE CONTRACTS

The Equipment Supplier is invited to provide a description of the O&M Service Contracts they could offer, assuming four such converter or substations are to be serviced. Two stations are to be located at different sites on Oahu, and one each on Molokai and Lanai. Budget servicing rates are to be supplied.

## TECHNICAL DATA REQUESTS

### HVDC LINE OPERATION DURING SYSTEM FAULTS

The Equipment Supplier shall confirm the capability of the converters and AC substation equipment to operate within at least the low voltage and high voltage ride through characteristics of Figure 1 for the purposes of this investigation. The actual requirements may vary.

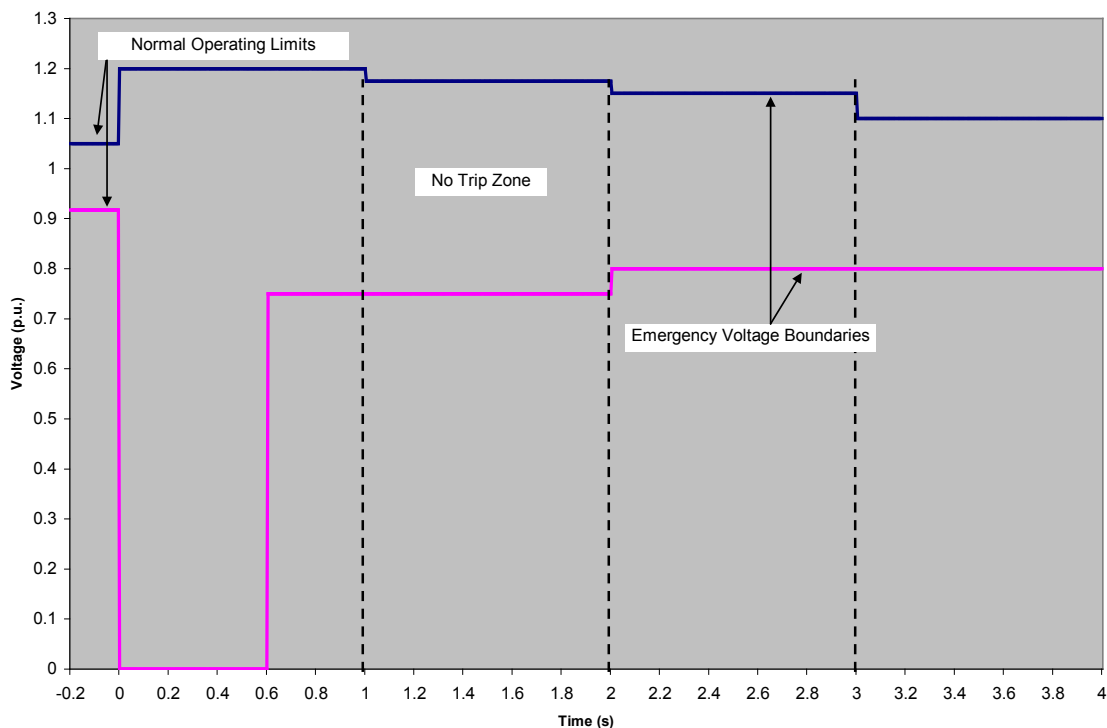

Figure 1: Undervoltage and overvoltage ride through characteristic

The Equipment Supplier shall confirm the capability of the converters and AC substation equipment to operate within at least the ac system frequencies as specified in Figure 2 for the purpose of this investigation. The actual requirements may vary.

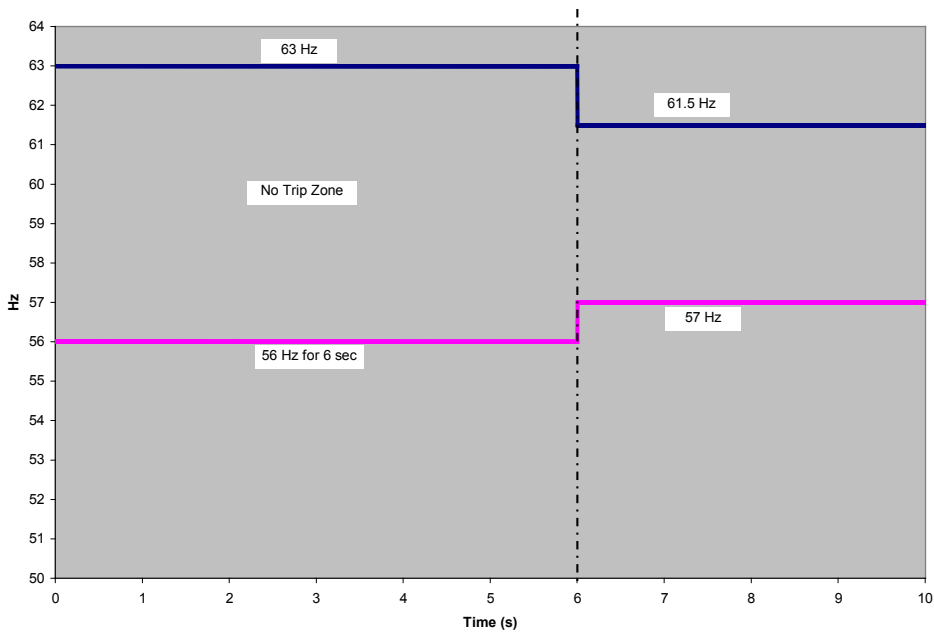

Figure 2: Operating frequency range of converter and substation equipment

## LOSSES

The following total losses for each of the HVDC Converter Stations and AC substation and equipment are to be supplied according to the loading level as indicated:

Losses at 10 % rated power \_\_\_\_\_ kW

Losses at 50 % rated power \_\_\_\_\_ kW

Failure Rate of one pair of HVDC Converter Stations/AC Substations ( at each end of one set of cables for one circuit ) in outages/year	
HVDC Converter Stations/AC Substations Forced Energy Unavailability (FEU) ( at each end of one set of cables for one circuit )	
HVDC Converter Station/AC Substation availability, considering only scheduled maintenance requirements (at each end of one set of cables for one circuit)	

Losses at 100% rated power \_\_\_\_\_ kW

**RELIABILITY**

The Equipment Supplier shall provide the expected reliability of each of the HVDC Converter Stations and AC substations, considering that there will be an HVDC Converter Station or AC Substation at each end of one circuit of an undersea cable. The reliability is to be estimated based on having a spare transformer or spare transformer phase (if comprised of single phase units) that can be put into service within 5 days. Similarly, the estimate of reliability should include the impact of shunt reactors for the AC options where replacement of a faulted phase must be replaced within two days.

Table 1: Calculated availability and reliability (HVDC/AC cables excluded)

**HVDC CONVERTER VALVES**

The Equipment Supplier shall provide the following information regarding the converter valves and associated equipment:

Table 2: Converter valve design

Type of solid state switching device	_____
Converter configuration (no. of levels, MMC, etc.)	_____
Continuous rating of total converter	MW _____
Rated direct voltage of each converter unit (150 kV Required)	kV _____
Rated direct current of each converter unit	amps _____
Number of converter units in total converter (one end)	_____
Maximum continuous overload current at low ambient temperature	amps _____
Phase or valve inductor per phase or bridge arm for each Converter Unit	mH _____

Positive reactive power (capacitive) at the high voltage busbar at rated power and excluding what is generated by the ac filters MVAR \_\_\_\_\_

Negative reactive power (inductive) at the high voltage busbar at rated power and excluding what is generated by the ac filters MVAR \_\_\_\_\_

Total reactive power rating of ac filters of converter MVAR \_\_\_\_\_

**HVDC CONTROLS AND PROTECTION**

The Equipment Supplier is to provide a description of the control and equipment strategy to accommodate a wind farm at the sending end. In addition, please provide a recommended strategy for control of AC voltage at ends taking into account there will be other equipments controlling AC voltage (wind turbine generators at one end and installed synchronous generators at the other end). The converters must be able to transmit power in both directions even though initially this may not be required.

**OCEAN PROFILE AND ISLAND CROSSINGS**

Preliminary bathymetry and ocean surveys have been conducted by SOEST at the University of Hawaii. Graphical information on ocean profile, depth, coverage and seabed composition is included in this request. Though no preferred island route has been identified, information provided relate to crossings between the relevant islands of Oahu, Molokai, Lanai and Maui.

**ACCURACY OF BUDGET ESTIMATES**

The anticipated accuracy of budget estimates shall be provided.

October22, 2009

To: High voltage power cable suppliers  
ABB (Each to be individually addressed)  
Fujikura  
Nexans  
Prysmian  
Sumitomo (J-Power)

**OAHU WIND INTEGRATION AND TRANSMISSION STUDY (OWITS)  
BUDGET PRICING OF INTER-ISLAND CABLE OPTIONS**

The US Department of Energy through the National Renewable Energy Laboratory (NREL) invites you to respond to this request for budget pricing information on various options for HVDC and AC undersea electric power cable transmission from the Hawaiian Islands of Molokai, Lanai and Maui to Oahu.

**Return Information**

Please return the completed budget pricing form (pages 7 to 17 below) to:

National Renewable Energy Laboratory  
Attn: David Corbus,  
1617 Cole Boulevard  
Golden, CO 80401-3393  
USA

Email: [David.Corbus@nrel.gov](mailto:David.Corbus@nrel.gov)

By November 20, 2009.

**Confidentiality**

The information received from NREL through this request is confidential and must be treated as such. Likewise, the recipient of this request will not have their name or association with the information submitted to NREL on the budget pricing form disclosed to anyone other than the team specifically assigned to evaluate this project.

## **Background to the Project**

This request follows a similar request for budget pricing of HVDC converter station and AC substation options that have already been sent out to equipment suppliers. This request is in response to the Hawaii Clean Energy Initiative (HCEI), which is a multiyear initiative with the State of Hawaii. HCEI is to provide technical support to the State to meet a self-imposed goal of 70% clean energy use through renewables and efficiency in the electricity and transportation sector by the year 2030 (40% by renewables).

One of the driving forces for FY09/10 work is the signed agreement between the State and Hawaiian Electric Company (HECO), Inc. that includes a combined commitment of up to 100 MW of on-island wind resources and up to 400 MW of wind on the Islands of Lanai and Molokai via an inter-island cable that would bring that wind energy to Oahu.

To support the HCEI and HECO efforts, the Oahu Wind Integration and Transmission Study (OWITS) study has been initiated. The goal of OWITS is to help stakeholders, with special emphasis on the utility and the state, to understand the costs and operating impacts of significant amounts of wind power on their island grids and to help them identify the technical requirements of and configuration for an undersea inter-island cable to transmit electricity from large wind and or solar systems from one island to another island.

The HECO system on Oahu is today an island system without inter-ties to neighboring islands. With potential for at least 100 MW of on-island wind generation, the impacts of additional wind variability and transient impacts on grid reliability due to connecting neighbor island wind all need to be carefully considered.

It can be assumed that the HECO system will only be able to allow a 200 MW loss due to any single point of failure.

There is a number of cable routing options from the islands of Molokai, Lanai and Maui to Oahu. Six options are for HVDC cables at  $\pm 150$  kV and a seventh option is for HVAC cables at 230 kV. A description of each option is included with each request along with seabed information. With up-to-date cable and termination pricing, it will be possible to select a preferred configuration for the interconnections. The HVDC options will be with Voltage Sourced Converters (VSC) which will allow solid XLPE type cable to be applied.

The connections from Molokai and Lanai to Oahu can be considered as a first stage development and can be scheduled to be placed in service in a practical sequence. A future interconnection from Maui to Oahu is a second stage development that does not require costs at this stage. Possible landing points for the cables are shown in Figure 1.



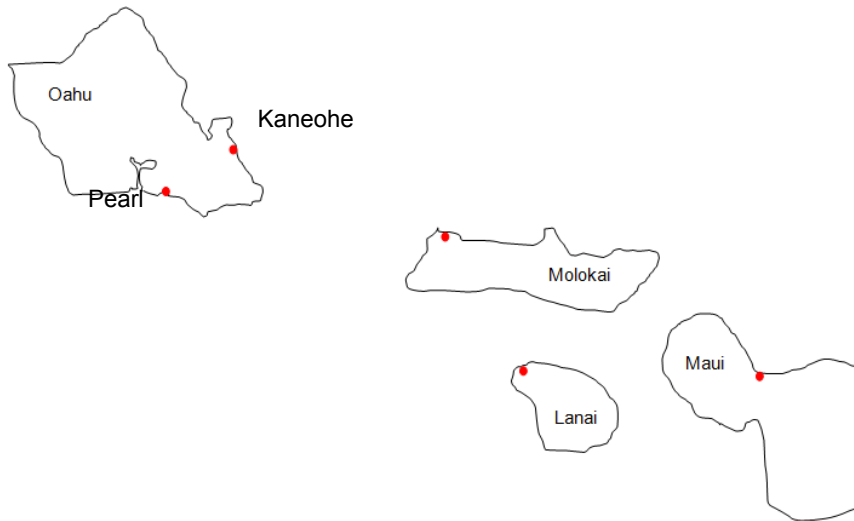

Figure 1: Possible cable landing points on the Hawaiian Islands.

### **Budget Pricing Requirements**

Budget pricing is required for seabed survey, cable design, manufacture, transportation, laying, splicing, burying in the sea bed where required, horizontal directional drilling to an on-shore transition station and a 1 km underground cable installation to an HVDC converter station (or AC substation). Necessary cable accessories are to be included in the cable budget prices along with inclusion of normally supplied spares for such application.

The budget prices are to be submitted as if they were being quoted for immediate installation of all stages, and are to be submitted in current US dollars.

Permitting and licensing costs are not to be included in the budget prices submitted.

The connection to the receiving end of the interconnections on Oahu will be the HECO system.

### **Cable Options**

The HVDC cables will be for operation with voltage sourced converters at  $\pm 150$  kV. AC cable options are being considered for 230 kV. Budget prices for the HVDC converter stations and AC substations are being requested separately. Climate is considered tropical.

### **Cable Burying**

It is required that the cable be buried along its full length to depths appropriate to the composition of the seabed and to protect it against fishing, ships anchors and marine life, yet allow recovery for repairs if so needed.

For the approach to the southern shore of Oahu and designated as "Pearl" in the seabed information (since the cable will enter Pearl Harbor for this landing site), there is

considerable dumped military equipment and ordinance on the seabed. This extends for a distance of approximately 6 miles (10 km) offshore. Careful survey will be required to determine a suitable route into Pearl Harbor.

No cable laying activity will be permitted for six months each year through the whale sanctuary (see Figure 2).



Figure 2: Humpback whale sanctuary

### **Existing Cables**

There are existing telecommunication cables shown in red in Figure 3 that will be crossed by the power cables. The budget price request for the various power cable options to Oahu must include additional costs incurred when the power cables cross the existing telecommunication cables.

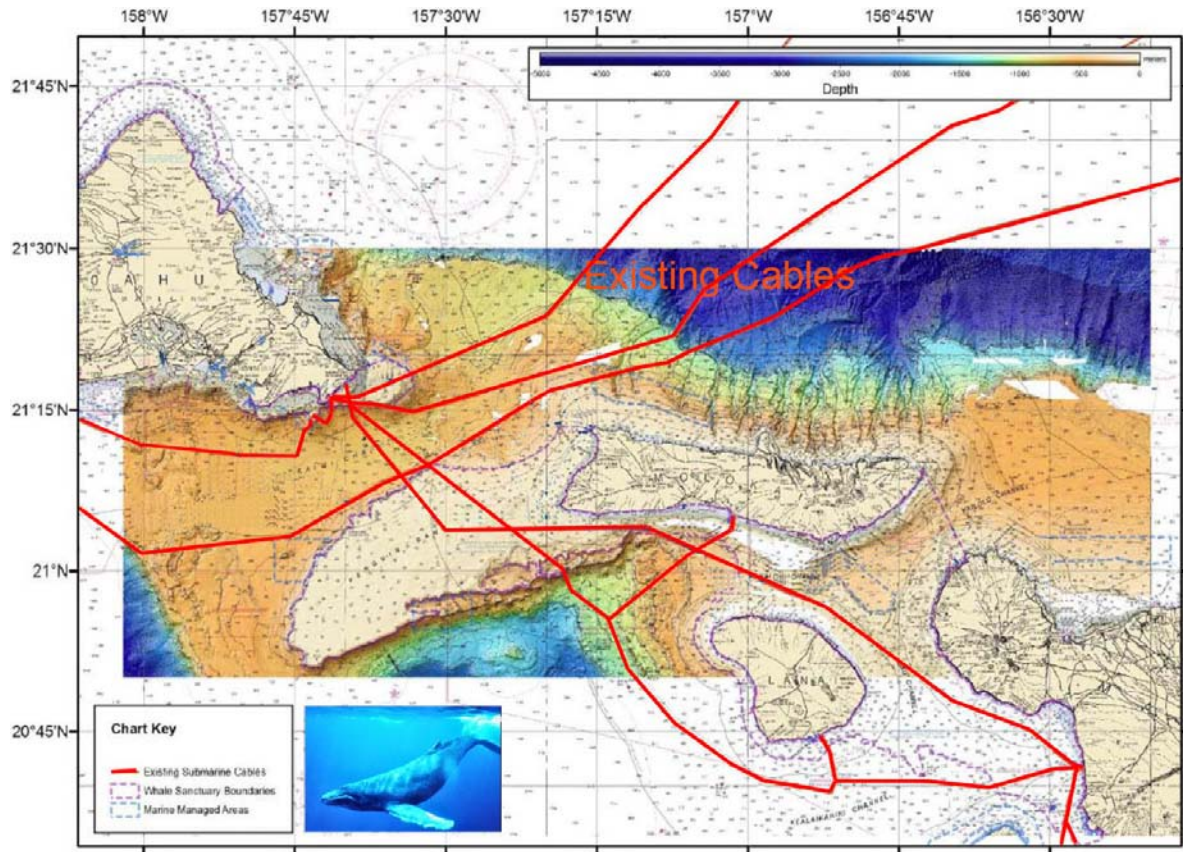

Figure 3: Locations of existing telecommunication cables

### DC Cable Options

There are two landing sites on Oahu for the cables from Molokai and Lanai. The south shore landing site is Pearl, and the west shore landing is Kaneohe (see Figure 1). The DC cable options for which budget prices are required are for  $\pm 150$  kV for bipole or symmetrical monopole converter station configuration and are listed as follows:

DC Cable Option 1: Molokai to Kaneohe, three cables 60 km long, two rated at 150 kV and 1,333 amps and the third at 50 kV and 1,333 A as a metallic return.

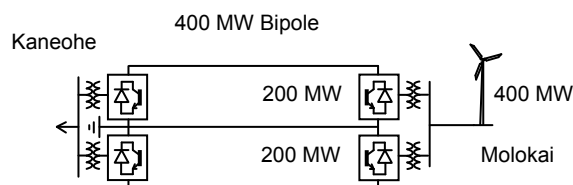

Figure 4: DC Cable Option 1

DC Cable Option 2: Molokai to Pearl, three cables 87 km long, two rated at 150 kV and 1,333 amps and the third at 50 kV and 1,333 A as a metallic return.

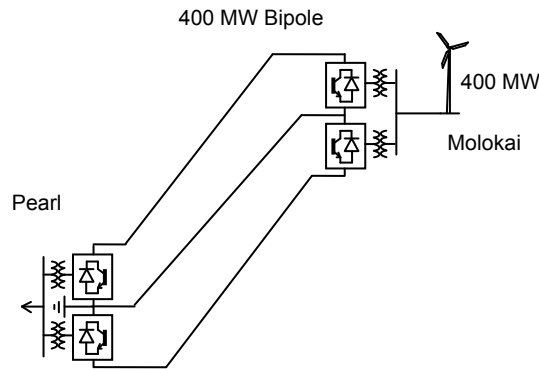

Figure 5: DC Cable Option 2

DC Cable Option 3: Molokai to Kaneohe, two cables 60 km long each rated at 150 kV and 667 amps. Molokai to Pearl, two cables 87 km long each rated at 150 kV and 667 amps.

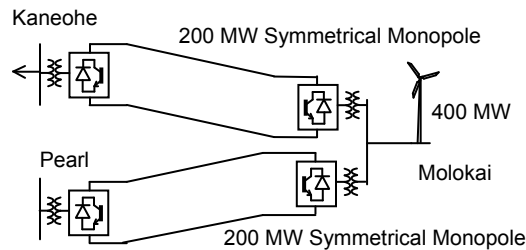

Figure 6: DC Cable Option 3

DC Cable Option 4: Molokai to Kaneohe, two cables 60 km long each rated at 150 kV and 667 amps. Lanai to Pearl, two cables 126 km long with one rated at 150 kV and 1,333 amps and the other as a metallic return cable rated at 50 kV and 1,333 amps. Molokai to Pearl, two cables 64 km long each rated at 150 kV and 667 amps. The pole configuration between Lanai and Pearl is to accommodate a future second stage polar extension to Maui.

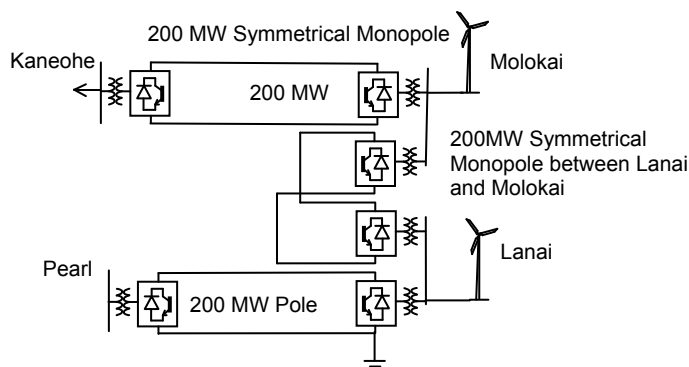

Figure 7: DC Cable Option 4

DC Cable Option 5: Molokai to Kaneohe, two cables 60 km long each rated at 150 kV and 667 amps. Lanai to Kaneohe, two cables 120 km long each rated at 150 kV and 667 amps.

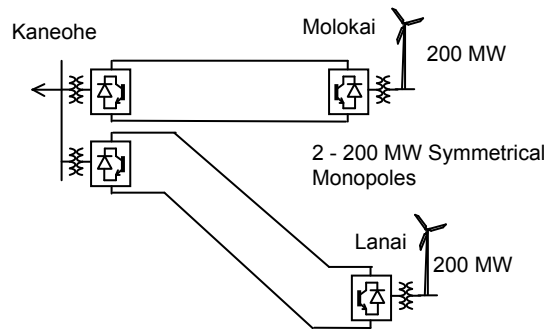

Figure 8: DC Cable Option 5

DC Cable Option 6: Molokai to Pearl, two cables 87 km long each rated at 150 kV and 667 amps. Lanai to Pearl, two cables 126 km long with each rated at 150 kV and 667 amps.

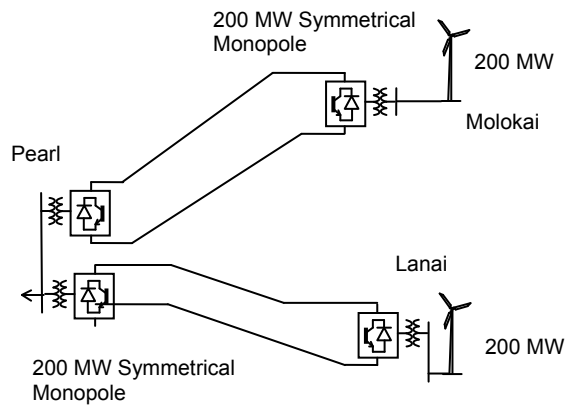

Figure 9: DC Cable Option 6

## AC Cable Option

One ac cable option is under investigation. Each ac cable can be either three single core, XLPE coaxial cables laid in trefoil formation or one three core XLPE cable.

AC Cable Option: Molokai to Kaneohe, one three phase circuit 60 km long rated at 230 kV and 650 amps rms. Lanai to Pearl, one three phase circuit 126 km long rated at 230 kV and 700 amps rms.

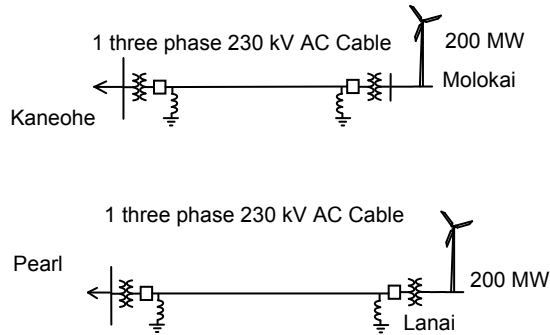

Figure 10: AC Cable Option

## Seabed Assessment

A preliminary seabed assessment is available for the proposed power cable routes between Oahu, Molokai and Lanai. These are presented as follows:

### Kaneohe to Molokai

This route is 60 kilometers long, with approximately 15-18 kilometers shallower than 125 meters, mostly living and relict coral, at the landward ends, each of which dips gently seaward over about 8 kilometers. The central 35 kilometers or so lies deeper than 600 meters, approaching a maximum depth of 800 meters, and this section is relatively flat at a broad scale. It is likely that much of this is sandy mud, although there will be blocks of coral rubble that has slid from both marginal platforms based. Conservatively, it is estimated that there may be 20 kilometers of soft sediment and 15 kilometers of rubble here. The slopes on each side will also have significant amounts of coarse debris and rubble shed from the reefs above them and some in situ reef outcrops that have been drowned by island subsidence. There was difficulty getting penetration or significant recovery with a corer on either margin, thus it is estimated the slope to be between 125 and 600 meters consolidated sand and carbonate rubble/outcrops.

Summary, Kaneohe to Molokai: Living/relict reef: 20 kilometers. Consolidated sand and rubble: 20 kilometers. Unconsolidated sandy mud: 20 kilometers. See Figures 11 and 12.

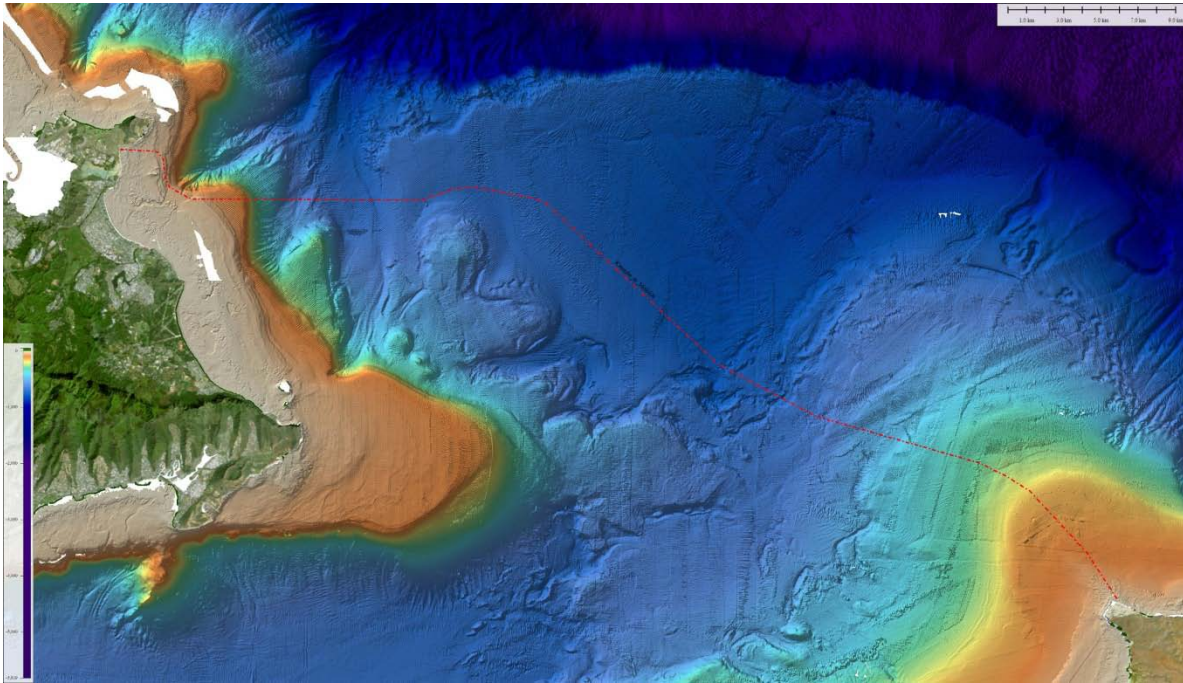

Figure 11: Route for Kaneohe to Molokai cables

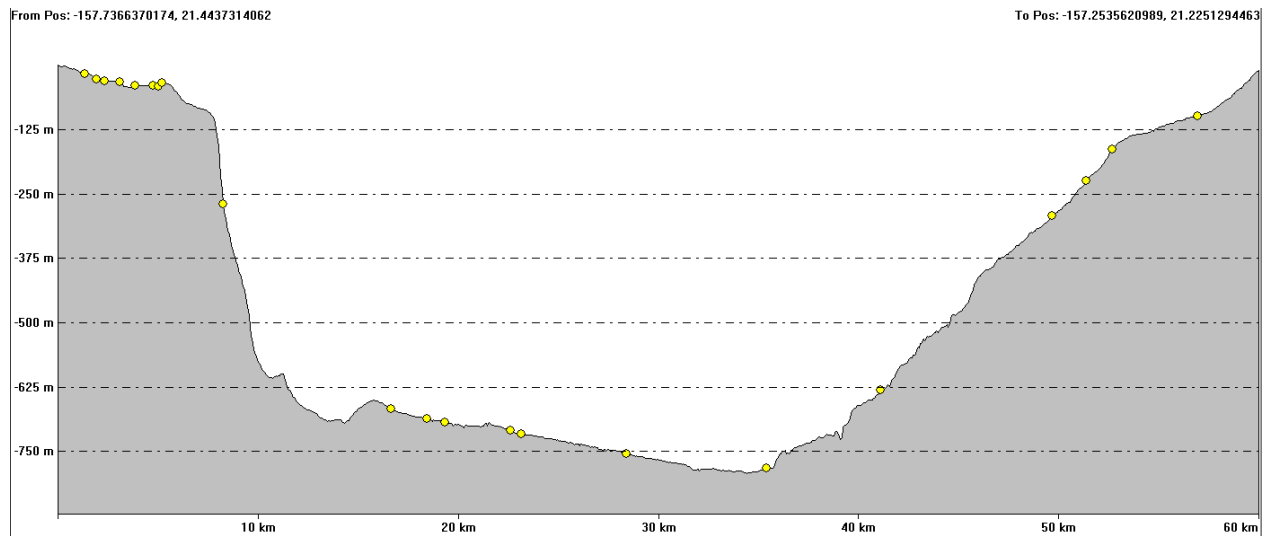

Figure 12: Bathymetric data for the cable route between Kaneohe and Molokai.

### **Kaneohe to Lanai**

The initial 60 kilometers of this route is identical to that above, from Kaneohe to NW Molokai, thus the sediment types are the same. The remaining 64 kilometers from Ilio Point on the NW corner of Molokai to the Lanai landing site, is mainly in water shallower than 100 meters, mostly 50 to 100 meters, and thus a mixture of living and dead reef and carbonate sands. Approximately 20 kilometers lies deeper than 125 meters, to a maximum depth of about 275 meters. This route is also swept by fast currents, and most fine grained material

is swept away except in the lee of obstacles. It would be reasonable to assume that most of it is consolidated sand and rubble.

Summary, Kaneohe to Lanai: (including estimates above for Kaneohe to Molokai):  
Living/dead reef: 64 kilometers. Consolidated sand and rubble: 40 kilometers.  
Unconsolidated sandy mud: 20 kilometers. See Figures 13 and 14.

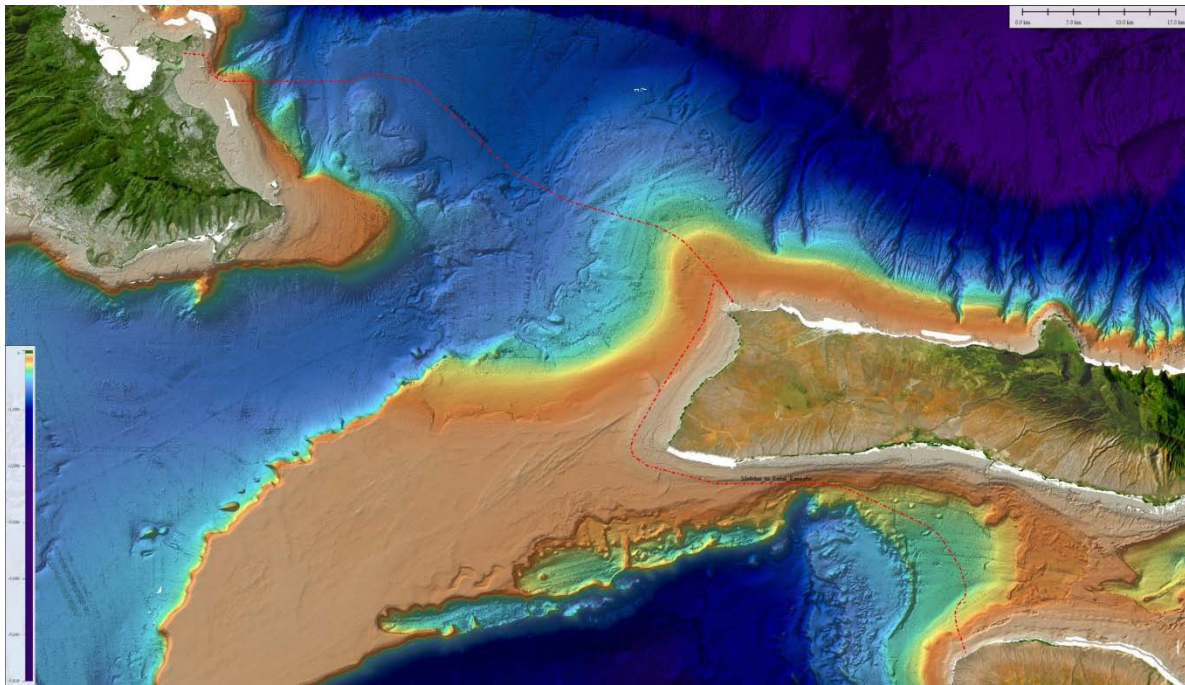

Figure 13: Route for Kaneohe to Lanai cables



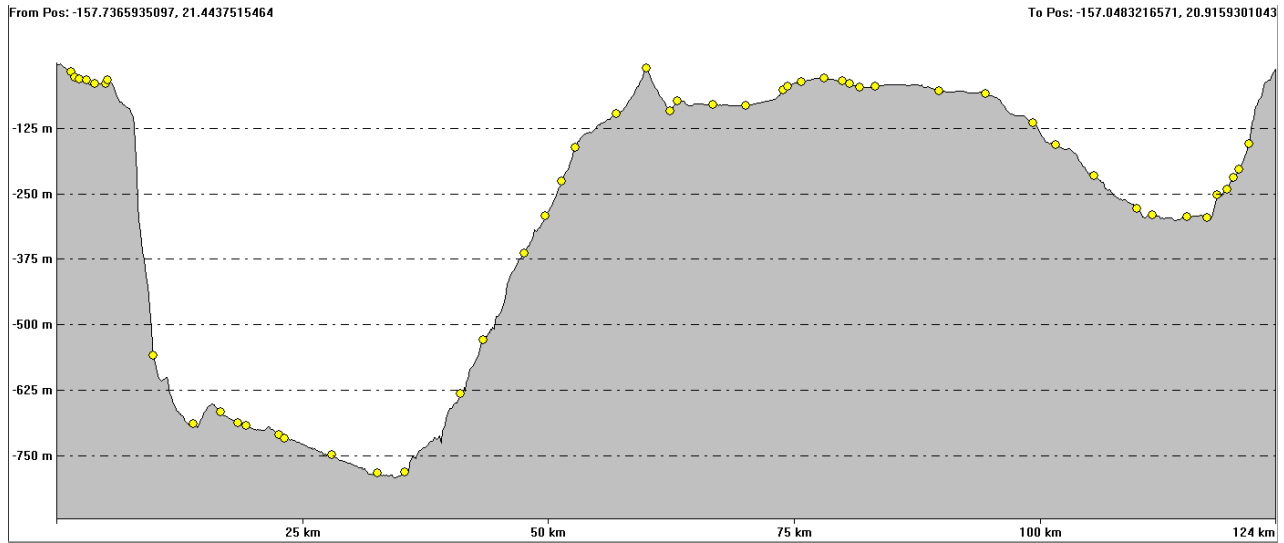

Figure 14: Bathymetric data for the cable route between Kaneohe and Lanai.

### **Pearl Harbor to Lanai**

This route is 126 km long. It begins with a nominal five kilometers in the dredged channel entering Pearl Harbor, assumed here to be hard ground dredged through living and dead reef. There is an additional 25 kilometers of less than 125 meters depth, including the section crossing the northern end of Penguin Bank, considered mostly to be living reef and carbonate sand, and the approach to the Lanai landing. The central channel region between Oahu and Penguin Bank includes about 55 kilometers deeper than 500 meters, deepest point slightly less than 700 meters, of which it is estimated that 35 kilometers is likely soft, unconsolidated sandy mud, and 20 kilometers, particularly along the base of Penguin Bank, is rubble and coarse debris shed from the bank with some reef outcrops predating island subsidence. There is 25 kilometers along the slope south of Molokai and crossing the channel between Molokai and Lanai, where depths range between 125 and 300 meters; as in previous sections, this current-swept region is mainly consolidated sand and coarse material, including reef debris. Of the remaining 16 kilometers, on the slopes south of Oahu and rising up Penguin Bank, it is estimated that perhaps 5 kilometers is soft unconsolidated sandy muds, while the remaining 11 kilometers is rubble or hard outcrops, particularly on the slope of Penguin Bank.

**Summary Pearl Harbor to Lanai:** 30 kilometers of living/dead reef. 56 kilometers of consolidated sand and rubble. 40 kilometers of unconsolidated sandy muds. Up to ten kilometers of the route, mostly across unconsolidated sediment south of Pearl and Honolulu Harbors, contains discarded munitions and other anthropogenic debris, some potentially quite hazardous. See Figures 15 and 16.

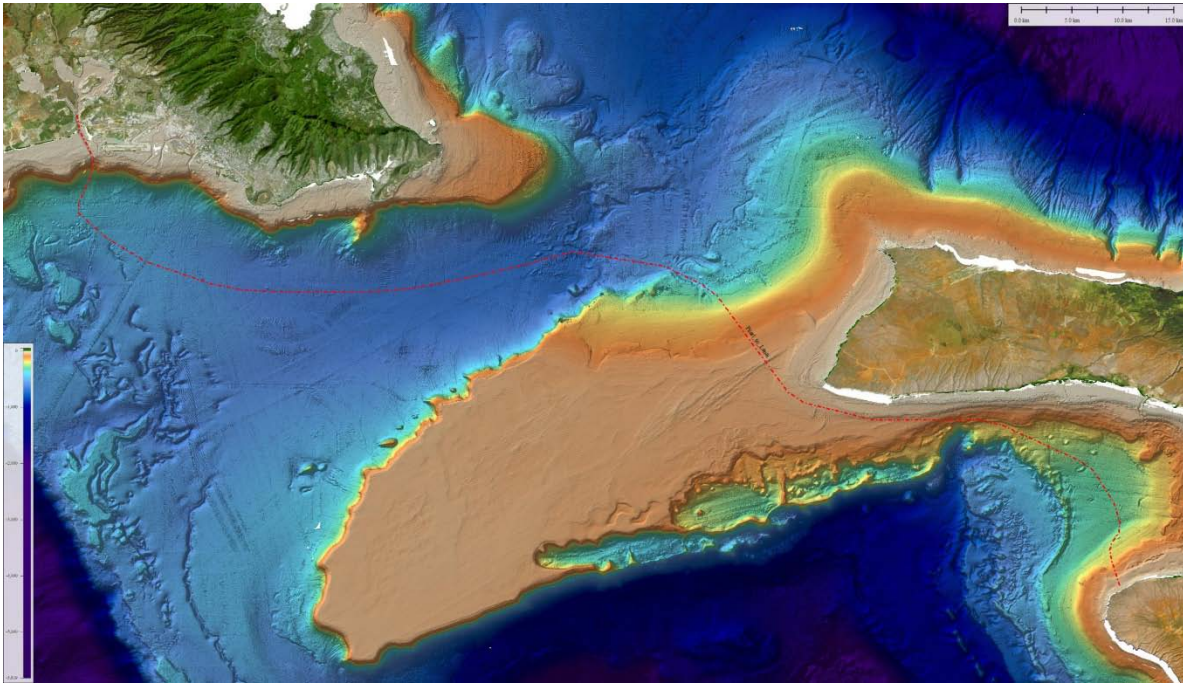

Figure 15: Route for Pearl to Lanai cables

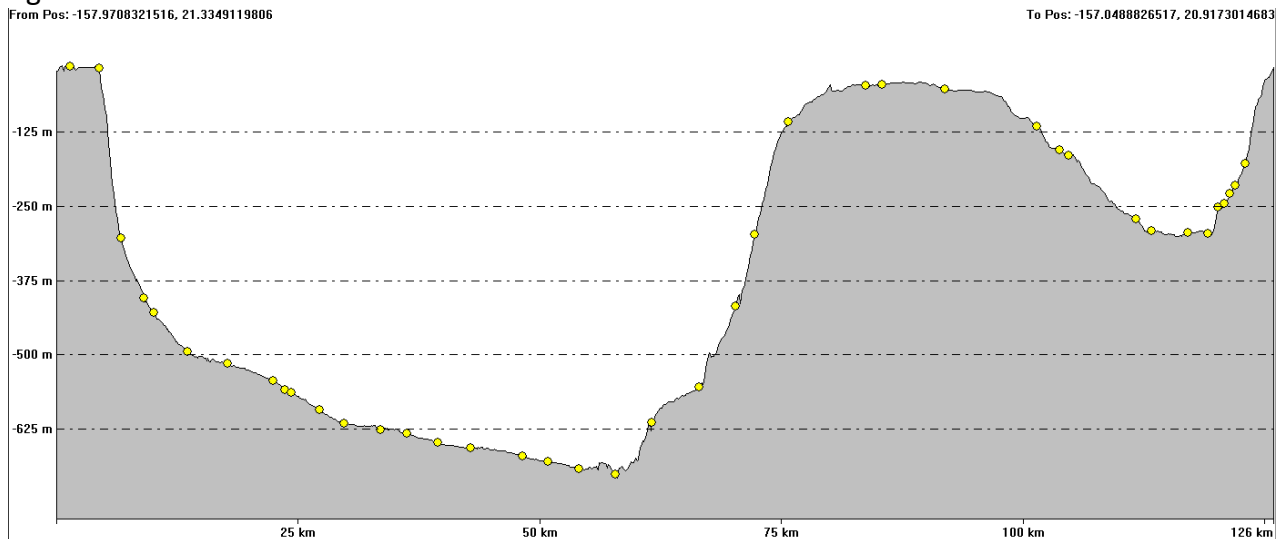

Figure 16: Bathymetric data for the cable route between Pearl and Lanai.

### **Pearl Harbor to Molokai**

This 87 kilometer route is the same as Pearl Harbor to Lanai for the first ~70 kilometers, then heads northeast up the slope to Ilio Point on the northwest corner of Molokai. The eastern portion is largely the western slope of Molokai and the approach to Ilio Point, neither of which is expected to have more than nominal amounts of unconsolidated sediment. It is inferred that most of the new stretch here on the approach to Molokai is consolidated sand and rubble, with 1-2 kilometers of living reef at the top of the slope.

**Summary, Pearl Harbor to NW Molokai:** 7 kilometers of living/dead reef. 40 kilometers of consolidated sand and rubble. 40 kilometers of unconsolidated sandy muds. Up to ten kilometers of the route, mostly across unconsolidated sediment of Pearl and Honolulu

Harbors, contain discarded munitions and other anthropogenic debris, some potentially quite hazardous. See Figures 17 and 18.

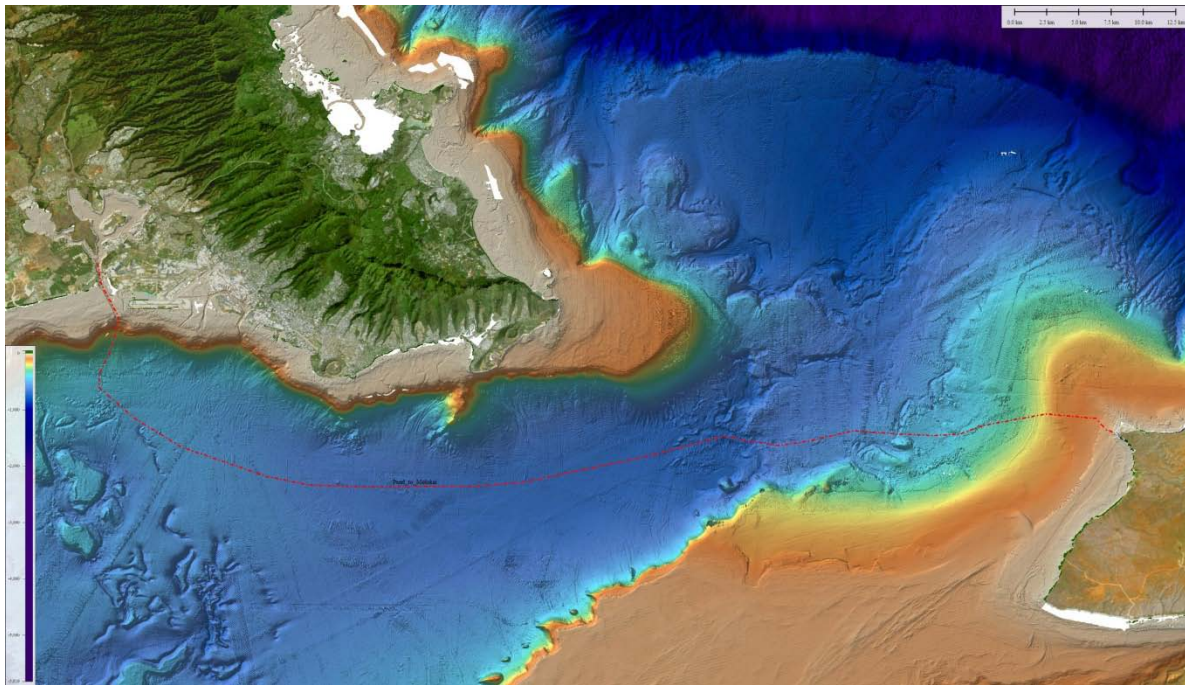

Figure 17: Route for Pearl to Molokai cables

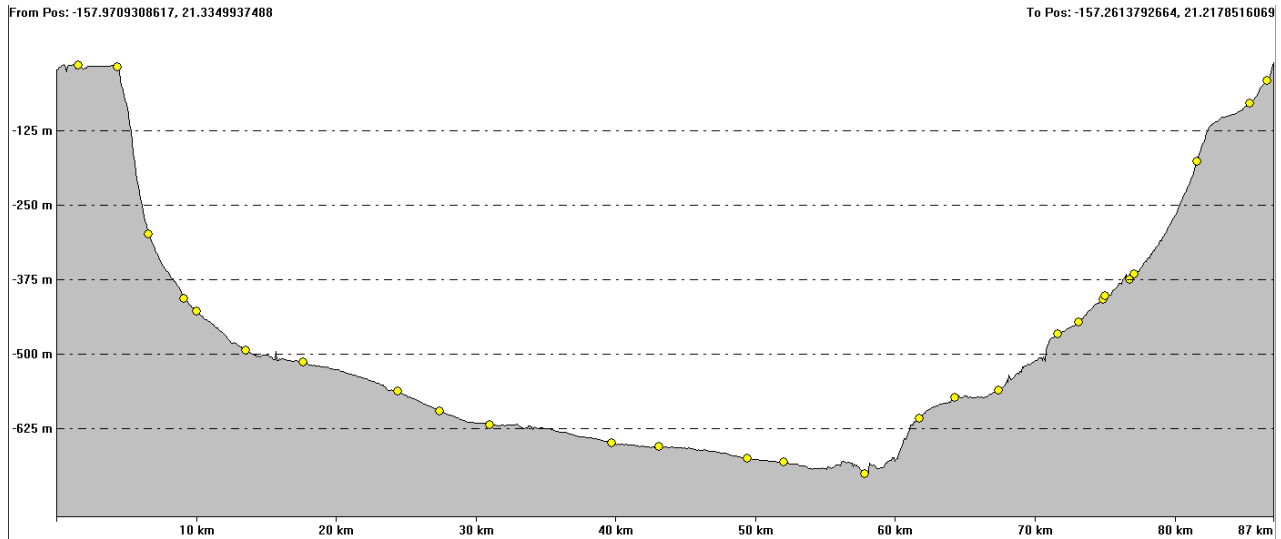

Figure 18: Bathymetric data for the cable route between Pearl and Molokai.

### **Molokai to Lanai**

The 64 kilometers from Molokai to the Lanai landing site, is mainly in water shallower than 100 meters, mostly 50 to 100 meters, and thus a mixture of living and dead reef and carbonate sands. Approximately 20 kilometers lies deeper than 125 meters, to a maximum depth of about 275 meters. This route is swept by fast currents, and most fine grained material is swept away except in the lee of obstacles. It would be reasonable to assume that most of it is consolidated sand and rubble.

Summary, Molokai to Lanai: Living/dead reef - 64 kilometers. See Figures 19 and 20.

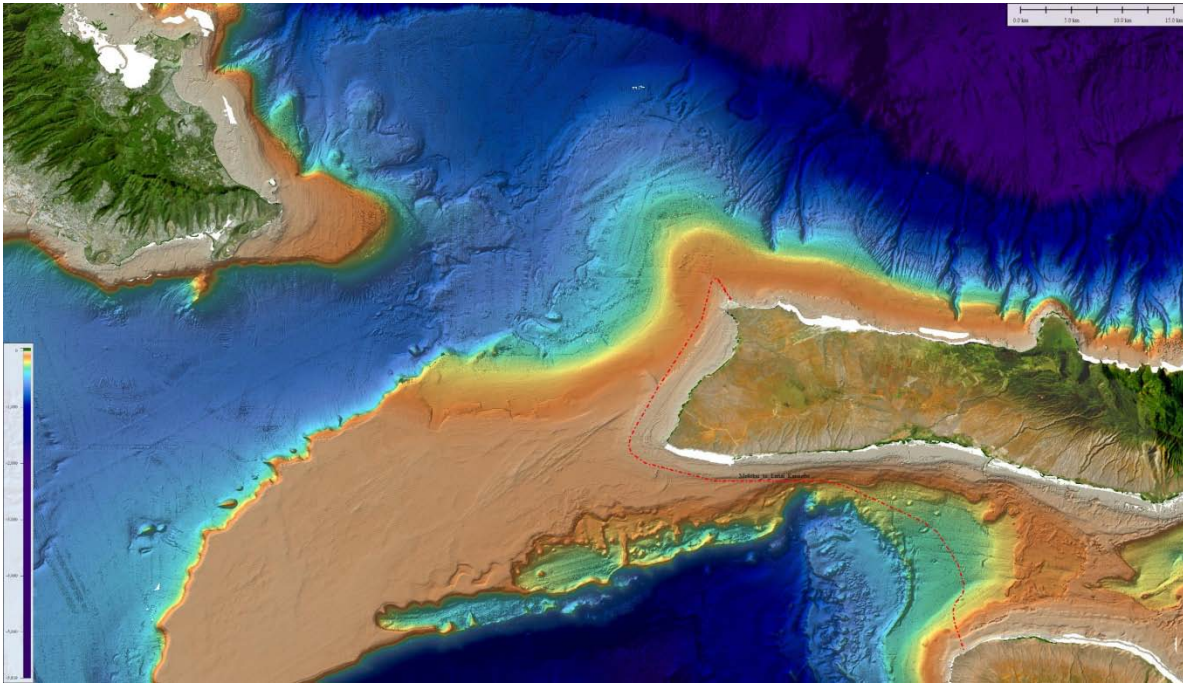

Figure 19: Route for Molokai to Lanai cables

From Pos: -157.2535620989, 21.2251294463

To Pos: -157.0483216571, 20.9159301043

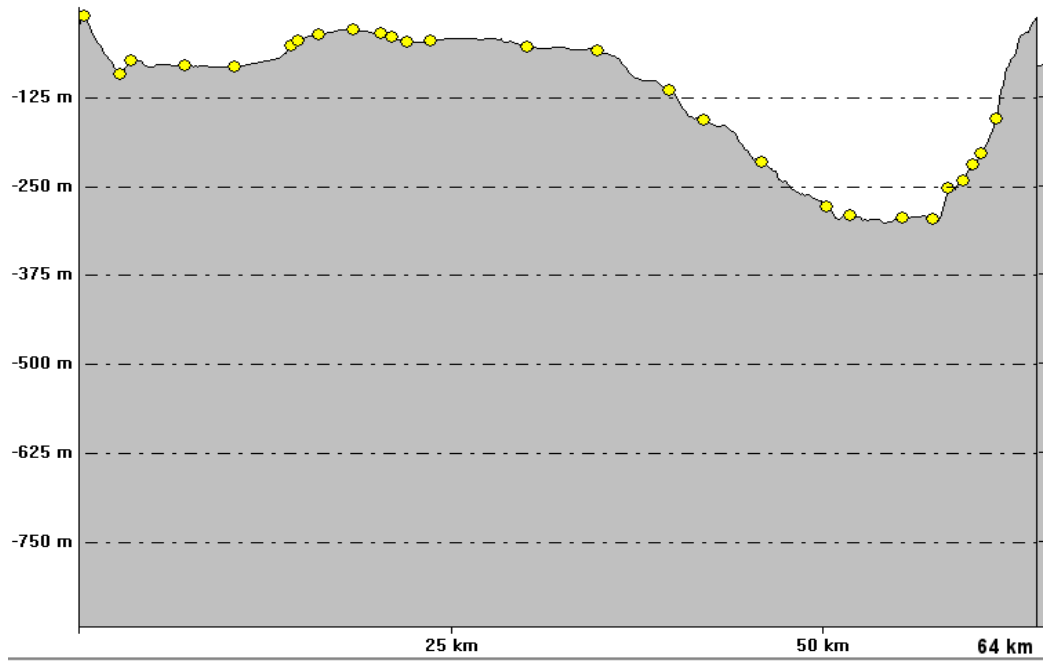

Figure 20: Bathymetric data for the cable route between Molokai and Lanai

---

**CABLE SUPPLIER'S NAME**

**Project: Oahu Wind Integration and Transmission Study (OWITS)**

**HVDC and AC Undersea Cables**

**CABLE BUDGET PRICING FORM**

**PRICING**

Firm lump sum prices are to be provided for to all labor, materials, equipment, required spares that includes seabed survey, cable design, manufacture, transportation, laying, splicing, burying in the sea bed, horizontal directional drilling to an on-shore transition station and a 1 km underground cable installation to an HVDC converter station (or AC substation), and testing and commissioning of the HVDC and AC cable options.

For the purpose of evaluation the budget price shall be broken down as follows:

DC Cable Option 1: Molokai to Kaneohe, three cables 60 km long, two rated at 150 kV and 1,333 amps and the third at 50 kV and 1,333 A as a metallic return.

- |    |  |          |
|----|--|----------|
| 1. | Basic cable cost                                 | \$ _____ |
| 2. | Seabed survey                                    | \$ _____ |
| 3. | Laying and burial of cable                       | \$ _____ |
| 4. | HDD, and termination 1 km from shore (both ends) | \$ _____ |
| 5. | Duty, based on a _____ % rate                    | \$ _____ |
| 6. | Insurance  | \$ _____ |
| 7. | Total  | \$ _____ |

Additional information for DC Cable Option 1

- |     |   |              |
|-----|---|--------------|
| 8.  | Time from order to in-service                   | Months _____ |
| 9.  | Losses in HV cable at rated voltage and current | MW _____     |
| 10. | Losses in HV cable at rated voltage and no load | MW _____     |
| 11. | 30 minute current overload rating               | Amps _____   |

12. Please provide Catalog numbers of each cable and copy of catalog information including weight/m, cross-sectional dimensions and materials
13. Please provide recommended burial depths in the seabed.

DC Cable Option 2: Molokai to Pearl, three cables 87 km long, two rated at 150 kV and 1,333 amps and the third at 50 kV and 1,333 A as a metallic return.

1.	Basic cable cost	\$ _____
2.	Seabed survey	\$ _____
3.	Laying and burial of cable	\$ _____
4.	HDD, and termination 1 km from shore (both ends)	\$ _____
5.	Duty, based on a _____% rate	\$ _____
6.	Insurance	\$ _____
7.	Total	\$ _____

Additional information for DC Cable Option 2

8.	Time from order to in-service	Months _____
9.	Losses in HV cable at rated voltage and current	MW _____
10.	Losses in HV cable at rated voltage and no load	MW _____
11.	30 minute current overload rating	Amps _____
12.	Please provide Catalog numbers of each cable and copy of catalog information including weight/m, cross-sectional dimensions and material.	
13.	Please provide recommended burial depths in the seabed.	

DC Cable Option 3: Molokai to Kaneohe, two cables 60 km long each rated at 150 kV and 667 amps. Molokai to Pearl, two cables 87 km long each rated at 150 kV and 667 amps.

1.	Basic cable cost	\$ _____
2.	Seabed survey	\$ _____
3.	Laying and burial of cable	\$ _____
4.	HDD, and termination 1 km from shore (both ends)	\$ _____
5.	Duty, based on a _____% rate	\$ _____
6.	Insurance	\$ _____
7.	Total	\$ _____



Additional information for DC Cable Option 3

8. Time from order to in-service Months \_\_\_\_\_
9. Losses in HV cable at rated voltage and current MW \_\_\_\_\_
10. Losses in HV cable at rated voltage and no load MW \_\_\_\_\_
11. 30 minute current overload rating Amps \_\_\_\_\_
12. Please provide Catalog numbers of each cable and copy of catalog information including weight/m, cross-sectional dimensions and material
13. Please provide recommended burial depths in the seabed.

DC Cable Option 4: Molokai to Kaneohe, two cables 60 km long each rated at 150 kV and 667 amps. Lanai to Pearl, two cables 126 km long with one rated at 150 kV and 1,333 amps and the other as a metallic return cable rated at 50 kV and 1,333 amps. Molokai to Pearl, two cables 64 km long each rated at 150 kV and 667 amps. The pole configuration between Lanai and Pearl is to accommodate a future second stage polar extension to Maui.

1. Basic cable cost \$ \_\_\_\_\_
2. Seabed survey \$ \_\_\_\_\_
3. Laying and burial of cable \$ \_\_\_\_\_
4. HDD, and termination 1 km from shore (both ends) \$ \_\_\_\_\_
5. Duty, based on a \_\_\_\_\_% rate \$ \_\_\_\_\_
6. Insurance \$ \_\_\_\_\_
7. Total \$ \_\_\_\_\_

Additional information for DC Cable Option 4

8. Time from order to in-service Months \_\_\_\_\_
9. Losses in HV cable at rated voltage and current MW \_\_\_\_\_
10. Losses in HV cable at rated voltage and no load MW \_\_\_\_\_
11. 30 minute current overload rating Amps \_\_\_\_\_
12. Please provide Catalog numbers of each cable and copy of catalog information including weight/m, cross-sectional dimensions and material.
13. Please provide recommended burial depths in the seabed.

DC Cable Option 5: Molokai to Kaneohe, two cables 60 km long each rated at 150 kV and 667 amps. Lanai to Kaneohe, two cables 120 km long each rated at 150 kV and 667 amps.

- |    |  |          |
|----|--|----------|
| 1. | Basic cable cost                                 | \$ _____ |
| 2. | Seabed survey                                    | \$ _____ |
| 3. | Laying and burial of cable                       | \$ _____ |
| 4. | HDD, and termination 1 km from shore (both ends) | \$ _____ |
| 5. | Duty, based on a _____% rate                     | \$ _____ |
| 6. | Insurance  | \$ _____ |
| 7. | Total  | \$ _____ |

Additional information for DC Cable Option 5

- |     |   |              |
|-----|---|--------------|
| 8.  | Time from order to in-service   | Months _____ |
| 9.  | Losses in HV cable at rated voltage and current   | MW _____     |
| 10. | Losses in HV cable at rated voltage and no load   | MW _____     |
| 11. | 30 minute current overload rating   | Amps _____   |
| 12. | Please provide Catalog numbers of each cable and copy of catalog information including weight/m, cross-sectional dimensions and materials |              |
| 13. | Please provide recommended burial depths in the seabed.   |              |

DC Cable Option 6: Molokai to Pearl, two cables 87 km long each rated at 150 kV and 667 amps. Lanai to Pearl, two cables 126 km long with each rated at 150 kV and 667 amps.

- |    |  |          |
|----|--|----------|
| 1. | Basic cable cost                                 | \$ _____ |
| 2. | Seabed survey                                    | \$ _____ |
| 3. | Laying and burial of cable                       | \$ _____ |
| 4. | HDD, and termination 1 km from shore (both ends) | \$ _____ |
| 5. | Duty, based on a _____% rate                     | \$ _____ |
| 6. | Insurance  | \$ _____ |
| 7. | Total  | \$ _____ |

Additional information for DC Cable Option 6

- |    |                               |              |
|----|-------------------------------|--------------|
| 8. | Time from order to in-service | Months _____ |
|----|-------------------------------|--------------|

9. Losses in HV cable at rated voltage and current MW \_\_\_\_\_
10. Losses in HV cable at rated voltage and no load MW \_\_\_\_\_
11. 30 minute current overload rating Amps \_\_\_\_\_
12. Please provide Catalog numbers of each cable and copy of catalog information including weight/m, cross-sectional dimensions and material
13. Please provide recommended burial depths in the seabed.

AC Cable Option: Molokai to Kaneohe, one three phase circuit 60 km long rated at 230 kV and 650 amps rms. Lanai to Pearl, one three phase circuit 126 km long rated at 230 kV and 700 amps rms.

1. Basic cable cost \$ \_\_\_\_\_
2. Seabed survey \$ \_\_\_\_\_
3. Laying and burial of cable \$ \_\_\_\_\_
4. HDD, and termination 1 km from shore (both ends) \$ \_\_\_\_\_
5. Duty, based on a \_\_\_\_\_ % rate \$ \_\_\_\_\_
6. Insurance \$ \_\_\_\_\_
7. Total \$ \_\_\_\_\_

Additional information for AC Cable Option

7. Time from order to in-service Months \_\_\_\_\_
8. Losses/phase at rated voltage and current MW \_\_\_\_\_
9. Losses/phase at rated voltage and no load MW \_\_\_\_\_
10. 30 minute current overload rating Amps \_\_\_\_\_
11. Please provide Catalog numbers of each cable and copy of catalog information including weight/m, cross-sectional dimensions and materials
12. Please provide recommended burial depths in the seabed.

**OFFER OF ALTERNATIVES**

The Cable Supplier shall provide budget prices on the work exactly as requested. However, the Cable Supplier is invited to

offer alternatives. If an alternative is offered, the Cable Supplier shall state clearly in what way the alternative differs from what has been requested, why such alternative work is offered. The prices for alternative work shall be set out in the same manner as for the work specified.

### **DELIVERY TIMES**

The Cable Supplier shall provide the delivery times from receipt of order until the cables have been tested and commissioned and made available for commercial operation.

### **EVIDENCE OF CABLE SUPPLIER'S ABILITY, EXPERIENCE AND PLANT**

The Cable Supplier is invited to provide evidence of ability and experience to supply the HVDC and AC cables as requested. The Cable Supplier shall include experience in providing HVDC and HVAC undersea cables as requested herein including their ratings, year of installation, Owner's contact name, phone number and email address.

### **WARRANTIES**

The Cable Supplier is invited to provide a written description of the performance and equipment warranties that would be offered, including budget prices.

### **OPERATION & MAINTENANCE SERVICE CONTRACTS**

The Cable Supplier is invited to provide a description of the O&M Service Contracts they could offer. Budget servicing rates are to be supplied.

### **REPAIR**

The Cable Supplier shall provide the expected repair time it will take after a cable fault has occurred. Note, that for a period of six months each year no repair activity may be possible due to whales resident in the whale sanctuary (See Figure 2).

### **ACCURACY OF BUDGET ESTIMATES**

The anticipated accuracy of budget estimates shall be provided.

# REPORT DOCUMENTATION PAGE

*Form Approved*  
OMB No. 0704-0188

The public reporting burden for this collection of information is estimated to average 1 hour per response, including the time for reviewing instructions, searching existing data sources, gathering and maintaining the data needed, and completing and reviewing the collection of information. Send comments regarding this burden estimate or any other aspect of this collection of information, including suggestions for reducing the burden, to Department of Defense, Executive Services and Communications Directorate (0704-0188). Respondents should be aware that notwithstanding any other provision of law, no person shall be subject to any penalty for failing to comply with a collection of information if it does not display a currently valid OMB control number.

**PLEASE DO NOT RETURN YOUR FORM TO THE ABOVE ORGANIZATION.**

<b>1. REPORT DATE (DD-MM-YYYY)</b> February 2011			<b>2. REPORT TYPE</b> Subcontract Report			<b>3. DATES COVERED (From - To)</b> 2008 - 2011		
<b>4. TITLE AND SUBTITLE</b> Oahu Wind Integration and Transmission Study (OWITS): Hawaiian Islands Transmission Interconnection Project					<b>5a. CONTRACT NUMBER</b> DE-AC36-08GO28308			
					<b>5b. GRANT NUMBER</b>			
					<b>5c. PROGRAM ELEMENT NUMBER</b>			
<b>6. AUTHOR(S)</b> Dennis Woodford					<b>5d. PROJECT NUMBER</b> NREL/SR-5500-50411			
					<b>5e. TASK NUMBER</b> SS101362			
					<b>5f. WORK UNIT NUMBER</b>			
<b>7. PERFORMING ORGANIZATION NAME(S) AND ADDRESS(ES)</b> Electranix Corporation 12 - 75 Scurfield Blvd Winnipeg, Manitoba R3Y 1G4 Canada					<b>8. PERFORMING ORGANIZATION REPORT NUMBER</b> LAM-9-99436-01			
<b>9. SPONSORING/MONITORING AGENCY NAME(S) AND ADDRESS(ES)</b> National Renewable Energy Laboratory 1617 Cole Blvd. Golden, CO 80401-3393					<b>10. SPONSOR/MONITOR'S ACRONYM(S)</b> NREL			
					<b>11. SPONSORING/MONITORING AGENCY REPORT NUMBER</b> NREL/SR-5500-50411			
<b>12. DISTRIBUTION AVAILABILITY STATEMENT</b> National Technical Information Service U.S. Department of Commerce 5285 Port Royal Road Springfield, VA 22161								
<b>13. SUPPLEMENTARY NOTES</b> NREL Technical Monitor: David Corbus								
<b>14. ABSTRACT (Maximum 200 Words)</b> This report provides an independent review included an initial evaluation of the technical configuration and capital costs of establishing an undersea cable system and examining impacts to the existing electric transmission systems as a result of interconnecting the islands.								
<b>15. SUBJECT TERMS</b> undersea cable; Maui; Lanai; Molokai; Hawaii Clean Energy Agreement; grid integration; operational impacts, transmission planning; Electranix; XLPE cable; voltage sourced converters								
<b>16. SECURITY CLASSIFICATION OF:</b>			<b>17. LIMITATION OF ABSTRACT</b> UL	<b>18. NUMBER OF PAGES</b>	<b>19a. NAME OF RESPONSIBLE PERSON</b>			
<b>a. REPORT</b> Unclassified	<b>b. ABSTRACT</b> Unclassified	<b>c. THIS PAGE</b> Unclassified			<b>19b. TELEPHONE NUMBER (Include area code)</b>			

Standard Form 298 (Rev. 8/98)  
Prescribed by ANSI Std. Z39.18