

Catalyst-Assisted Production of Olefins from Natural Gas Liquids: Prototype Development and Full-Scale Testing

New Process Produces Ethylene
More Efficiently and Reduces Coke
Formation

Ethylene, an important olefin, is a key building block in the production of numerous chemicals and polymers and the largest volume organic chemical produced in the United States and the world today. Ethylene also has one of the highest overall energy consumption totals compared to the production of other chemicals across the U.S. chemical industry. The production of ethylene from ethane is expected to grow significantly due to the exploitation of vast reserves of shale gas in the United States.

Most ethylene is produced through a 40-year-old process known as steam cracking. In this process, hydrocarbons are pyrolyzed at temperatures of 800°C–900°C and then cooled. Ethylene is separated from the resulting complex mixture by compression and distillation. Carbonaceous materials are produced as a by-product in the process and deposit on the internal surfaces of the coils. These coke deposits cause a number of undesirable side effects, including constricting the flow of ethylene through the furnace, forcing higher furnace temperatures to maintain performance, and eventually halting ethylene production to remove coke from the furnace walls.

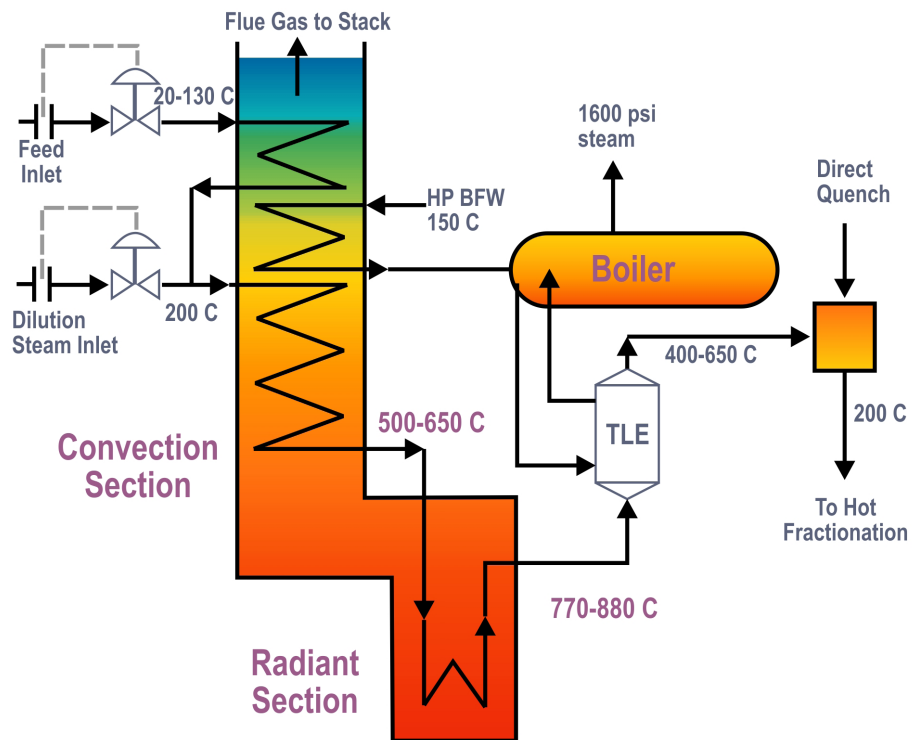

Typical ethylene production furnace. Photo courtesy of BASF Qtech

Using a conventional steam cracker, this project will develop and apply a novel catalytic coating on internal surfaces of the coils where ethane is converted at extremely high temperatures to ethylene. The catalyst contained in the coating catalyzes the oxidation of the carbon on the surface, greatly reducing coke formation and its associated problems.

Results from prototype tests using early generations of the catalytic coating and naphtha feedstock will serve as a good starting point, but this project will focus on ethylene produced from ethane feedstock. Researchers will eventually conduct full-scale prototype testing under real-world operating conditions.

Benefits for Our Industry and Our Nation

Catalyst-assisted production of olefins is expected to demonstrate a 6% reduction in overall plant energy consumption, with the potential of achieving a 10% reduction. Decoking downtime is expected to decrease significantly thereby reducing production costs while increasing ethylene productivity and the competitiveness of the U.S. chemical industry.

Applications in Our Nation's Industry

It will be possible to retrofit existing ethylene plants with this technology with little or no new capital investment. Additionally, this technology could also be tailored to produce catalyst and coating materials for applications in other extreme environmental conditions, such as energy nanomaterials for the methanol-hydrogen economy, materials for hydrogen storage, and materials for hydrogen manufacture.

Project Description

The project objective is to successfully manufacture prototype catalyst-coated furnace coils (tubes and fittings) and demonstrate their performance in the field under real-world conditions for the production of ethylene from ethane, while also minimizing the energy required for the process.

Barriers

Previous research provides a strong foundation for the proposed program, but cracking ethane feedstock presents its own specific challenges over naphtha, namely higher operating temperature and impurities. Barriers to overcome include the following:

- Producing catalyst coatings that meet laboratory-scale performance metrics that are also compatible with ethane furnace operating conditions.
- Obtaining the furnace coil alloy metallurgy necessary to manufacture coils that will provide satisfactory operating performance.

Pathways

Building on existing knowledge, the project will identify the combination of catalyst composition and catalyst thickness that has the potential to produce the greatest energy savings while allowing for satisfactory bonding of the catalytic coatings through the required decoking cycles. The manufacture of full-scale coils and installation in a commercial-scale furnace will allow researchers to collect and validate data in a relevant environment. Finally, researchers will conduct a full-scale field demonstration to demonstrate energy reduction and higher conversion and productivity.

Milestones

This project began in 2012.

- Catalyst Coating Manufacturing Technology Development (2013):
 - Verify welding of coated components after all coating-related heat treatments;
 - Achieve a minimum of a 2 times increase in internal surface area over uncoated tubular components and fittings; and
 - Demonstrate performance sustainability of the coated tube over at least 8 decoking cycles to simulate a commercial furnace.

- Prototype Trial Manufacturing (2014): Scale-up all manufacturing process technologies successfully developed in year 1 to apply catalyst coatings to sufficient tubes and fittings to retrofit the Project Furnace with coated prototype furnace coils. The coated coils will be installed in a commercial ethane steam cracker during a scheduled maintenance shutdown or “turnaround.”
- Field Demonstration Trial (2015): Achieve the following in the field demonstration of the ethane steam cracker unit: 3 – 10 fold increase in run lengths; 10° – 30°C reduction in tube metal temperature; and greater than 68% ethane conversions.

Commercialization

Industry partners will provide engineering and manufacturing expertise to focus on the installation and operation of the prototypes as well as performance evaluation. Once performance is verified and validated, Lyondell-Basell will serve as the starting point for technology deployment in the United States.

Project Partners

Lyondell Chemical Company
Houston, TX
Principal Investigator: Majid Keyvani
Email: majid.keyvani@lyondellbasell.com

Quantiam Technologies
Edmonton, Alberta, Canada

BASF Qtech
Iselin, NJ

For additional information, please contact

Dickson Ozokwelu
Technology Manager
U.S. Department of Energy
Advanced Manufacturing Office
Phone: (202) 586-8501
Email: Dickson.Ozokwelu@ee.doe.gov