

U.S. Department of Energy

Lake Charles Carbon Capture and Sequestration Project

Draft Environmental Impact Statement

April 2013
DOE/EIS-0464D



Office of Fossil Energy
National Energy Technology Laboratory

This page left blank intentionally.

COVER SHEET

Responsible Federal Agency: U.S. Department of Energy (DOE)

Title: Lake Charles Carbon Capture and Sequestration Project, Draft Environmental Impact Statement (DOE/EIS-0464D)

Location: Lake Charles, Louisiana located in Calcasieu Parish and West Hastings Oil Field, located in Brazoria County, Texas

Contact:

For further information about this Environmental Impact Statement, contact:

Pierina Fayish

U.S. Department of Energy

National Energy Technology Laboratory

P.O. Box 10940

Pittsburgh, PA 15236

412-386-5428

toll-free 1-888-322-7436, ext. 5428

LeucadiaEIS@NETL.DOE.GOV

For general information on the Department of Energy's process for implementing the National Environmental Policy Act, contact:

Carol Borgstrom, Director

Office of NEPA Policy and Compliance (GC-54)

U.S. Department of Energy

1000 Independence Avenue, SW

Washington, DC 20585-0103

(202) 586-4600 or leave message

at (800) 472-2756

Abstract:

This draft Environmental Impact Statement (EIS) provides information about the potential environmental impacts associated with the Department of Energy's (DOE) proposed action to provide financial assistance to Leucadia Energy, LLC (Leucadia) and with Leucadia's proposed Lake Charles Carbon Capture and Sequestration (CCS) project. DOE's proposed action would provide financial assistance to Leucadia under the Industrial Carbon Capture Sequestration (ICCS) Program to support construction and operation of Leucadia's Lake Charles CCS project. DOE proposes to provide Leucadia with up to \$261.4 million, which would constitute about 60 percent of the estimated \$435.6 million total development cost and capital cost of the project.

The Lake Charles CCS project would demonstrate the capture of carbon dioxide (CO₂) from an industrial facility for use in an existing, commercial enhanced oil recovery (EOR) operation in the West Hastings oil field. The industrial source of CO₂ would be a newly constructed gasification plant that converts petroleum coke into hydrogen gas, methanol, and other products. Lake Charles Clean Energy, LLC (an affiliate of Leucadia Energy, LLC) would build and own the gasification plant and the Lake Charles CCS project's proposed CO₂ capture and compression facilities. An affiliate of Denbury Onshore, LLC (Denbury) would construct, own and operate the new CO₂ pipeline connecting to the existing Green Pipeline. Denbury would use the captured CO₂ in its existing commercial EOR operation. Leucadia would jointly fund the research MVA program performed at the West Hastings oil field. Denbury and the University of Texas Bureau of Economic Geology (BEG) would design and implement the West Hastings Research MVA program. The research MVA will be conducted in conjunction with existing commercial EOR operations at the West Hastings oil field and will supplement regulatory requirements and Denbury's privately funded commercial monitoring activities. The Lake Charles CCS project would be designed to capture and sequester approximately 4.6 million tons of CO₂ per year that the facility would otherwise emit. The West Hastings research MVA program is aimed at providing an accurate accounting of approximately 1 million tons of stored CO₂ and a high level of confidence that the CO₂ will remain sequestered permanently in historic oil-producing geologic formations located approximately 6,500 feet below the land surface.

DOE is the lead federal agency responsible for preparation of this EIS. DOE prepared the EIS pursuant to the National Environmental Policy Act (NEPA) and in compliance with the Council on Environmental Quality (CEQ) implementing regulations for NEPA (40 Code of Federal Regulations [CFR] 1500 through 1508) and DOE NEPA procedures (10 CFR 1021). The EIS evaluates the potential environmental impacts of the Lake Charles CCS project as part of DOE's decision-making process to determine whether to provide Leucadia with financial assistance for the proposed project. This EIS also analyzes the no action alternative, under which DOE would not provide financial assistance for the Lake Charles CCS project.

Comment Period:

DOE encourages public participation in the NEPA process. Comments postmarked by June 24, 2013, will be addressed in the Final EIS, which will be used by DOE in its decision-making process for the proposed action. DOE will consider late comments to the extent practicable.

Table of Contents

<u>Chapter</u>	<u>Page</u>
Table of Contents	i
List of Tables.....	ix
List of Figures	xix
Acronyms and Abbreviations	xxi
Glossary	xxvii
Summary	1
S-1 DOE’s Proposed Action, Purpose, and Need.....	1
S-2 Leucadia’s Proposed Project.....	3
S-3 Affected Environment.....	20
S-4 Environmental Consequences.....	27
S-5 Potential Cumulative Impacts.....	36
S-6 Conclusions.....	36
1. Introduction.....	1-1
1.1 DOE’s ICCS Program.....	1-1
1.1.1 Legislative History.....	1-1
1.1.2 Project Selection Process	1-2
1.2 DOE’s Proposed Action.....	1-3
1.3 Purpose and Need for DOE Action.....	1-4
1.4 Leucadia’s Proposed Project.....	1-4
1.5 Scope of the Environmental Analysis.....	1-5
1.5.1 Scoping Process and Public Participation Activities	1-7
1.5.2 Resource Areas Considered and Issues Identified During the Scoping Process	1-8
1.5.3 Alternatives Considered.....	1-9
1.5.4 Incomplete and Unavailable Information	1-10
2. Proposed Action and Alternatives	2-1
2.1 DOE’s Proposed Action.....	2-1
2.2 Description of Leucadia’s Proposed Project.....	2-1
2.3 Project and Technology Descriptions	2-2
2.3.1 LCCE Gasification Plant (Connected Action).....	2-2
2.3.1.1 Major System Components.....	2-7

2.3.2	Lake Charles CCS Project	2-14
2.3.2.1	CO ₂ Capture and Compression	2-14
2.3.2.2	CO ₂ Pipeline.....	2-16
2.3.2.3	West Hastings Research MVA Program.....	2-19
2.4	Construction Plans	2-28
2.4.1	LCCE Gasification and Lake Charles CCS CO ₂ Capture and Compression	2-28
2.4.1.1	Resource Requirements	2-30
2.4.1.2	Outputs, Discharges, and Wastes.....	2-32
2.4.2	Lake Charles CCS Project CO ₂ Pipeline	2-33
2.4.2.1	Resource Requirements	2-35
2.4.2.2	Outputs, Discharges, and Wastes.....	2-35
2.4.3	West Hastings Research MVA Program.....	2-36
2.5	Operation Plans.....	2-36
2.5.1	LCCE Gasification Plant.....	2-36
2.5.1.1	Resource Requirements	2-37
2.5.1.2	Outputs, Discharges, and Wastes.....	2-41
2.5.2	Lake Charles CCS CO ₂ Capture and Compression	2-44
2.5.2.1	Resource Requirements	2-44
2.5.2.2	Outputs, Discharges, and Wastes.....	2-45
2.5.3	Lake Charles CCS Project CO ₂ Pipeline	2-45
2.5.3.1	Resource Requirements	2-46
2.5.3.2	Outputs, Discharges, and Wastes.....	2-46
2.5.4	West Hastings Research MVA	2-46
2.5.4.1	Resource Requirements	2-48
2.5.4.2	Outputs, Discharges, and Wastes.....	2-48
2.6	Alternatives.....	2-48
2.6.1	Alternatives to DOE’s Proposed Action.....	2-48
2.6.1.1	Alternatives Considered during the Selection Process	2-48
2.6.1.2	No Action Alternative.....	2-49
2.6.2	Project Alternatives under Consideration by the Applicant	2-49
	Alternate CO ₂ Pipeline Route.....	2-49
2.6.3	Project Alternatives Dismissed from Further Consideration by the Applicant.....	2-50
2.6.3.1	LCCE Gasification Plant.....	2-50
2.6.3.2	CCS Project.....	2-50
3.	Affected Environment	3-1
3.1	Introduction.....	3-1
3.2	Climate and Air Quality.....	3-2
3.2.1	Climate and Meteorology	3-2
3.2.2	Regional and Local Ambient Air Quality	3-4
3.2.3	Existing Emission Sources.....	3-6
3.3	Geology and Soils.....	3-7
3.3.1	Regional Geology	3-7
3.3.2	Stratigraphy and Structure	3-8
3.3.3	Mineral Resources	3-12

3.3.4	Seismology.....	3-14
3.3.5	Soil Classification and Description.....	3-14
3.3.6	Prime Farmland and Other Important Farmlands	3-23
3.4	Surface Water.....	3-23
3.4.1	Regional Hydrology.....	3-23
3.4.2	Surface Water Quality and Use.....	3-29
3.4.3	Wetlands	3-34
3.4.4	Floodplains.....	3-36
3.5	Groundwater	3-37
3.5.1	Regional Setting.....	3-37
3.5.2	Groundwater Quality and Use	3-39
3.6	Biology.....	3-40
3.6.1	Vegetation.....	3-40
3.6.2	Wildlife	3-44
3.6.3	Aquatic Ecology.....	3-46
3.6.4	Threatened and Endangered Species	3-47
3.6.5	Invasive Species.....	3-51
3.7	Cultural Resources.....	3-51
3.7.1	LCCE Gasification and Lake Charles CCS Project CO ₂ Capture and Compression Facilities	3-53
3.7.2	CO ₂ Pipeline.....	3-55
3.7.3	West Hastings Research MVA	3-56
3.8	Land Use.....	3-57
3.8.1	LCCE Gasification Plant and Lake Charles CCS CO ₂ Capture and Compression Facilities.....	3-57
3.8.2	Hastings Oil Field, Texas.....	3-66
3.9	Socioeconomics and Environmental Justice.....	3-67
3.9.1	Socioeconomics	3-67
3.9.1.1	Population and Housing.....	3-67
3.9.1.2	Economy and Employment.....	3-73
3.9.1.3	Fiscal	3-76
3.9.1.4	Community/Public Services.....	3-78
3.9.2	Environmental Justice.....	3-79
3.9.2.1	LCCE Gasification and CO ₂ Capture and Compression Facilities.....	3-80
3.9.2.2	CO ₂ Pipeline Route	3-81
3.9.2.3	West Hastings Research MVA	3-84
3.10	Traffic and Transportation	3-87
3.10.1	Regional and Local Roadway System	3-87
3.10.2	Waterway and Rail Transportation	3-93
3.10.3	Airports	3-94
3.11	Noise	3-94
3.12	Wastes and Materials	3-97
3.13	Human Health and Safety	3-100

4.	Environmental Consequences.....	4-1
4.1	Introduction.....	4-1
4.2	Climate and Air Quality.....	4-2
4.2.1	Factors Considered for Assessing Impacts.....	4-2
4.2.2	LCCE Gasification (Connected Action).....	4-3
4.2.2.1	Construction.....	4-3
4.2.2.2	Operation.....	4-4
4.2.3	Lake Charles CCS Project.....	4-8
4.2.3.1	CO ₂ Capture and Compression Facilities.....	4-8
4.2.3.2	CO ₂ Pipeline.....	4-9
4.2.3.3	West Hastings Research MVA.....	4-10
4.2.4	Conformity Analysis.....	4-11
4.3	Geology and Soils.....	4-13
4.3.1	Factors Considered for Assessing Impacts.....	4-13
4.3.2	LCCE Gasification Plant (Connected Action).....	4-14
4.3.2.1	Construction.....	4-14
4.3.2.2	Operation.....	4-17
4.3.3	Lake Charles CCS Project.....	4-18
4.3.3.1	CO ₂ Capture and Compression Facilities.....	4-18
4.3.3.2	CO ₂ Pipeline.....	4-18
4.3.3.3	West Hastings Research MVA.....	4-19
4.4	Surface Water, Floodplains, and Wetlands.....	4-24
4.4.1	Factors Considered for Assessing Impacts.....	4-24
4.4.2	LCCE Gasification (Connected Action).....	4-25
4.4.2.1	Construction.....	4-25
4.4.2.2	Operation.....	4-34
4.4.3	Lake Charles CCS Project.....	4-37
4.4.3.1	CO ₂ Capture and Compression Facilities.....	4-37
4.4.3.2	CO ₂ Pipeline.....	4-37
4.4.3.3	West Hastings Research MVA Program.....	4-44
4.5	Groundwater Impacts.....	4-48
4.5.1	Factors Considered for Assessing Impacts.....	4-48
4.5.2	LCCE Gasification (Connected Action).....	4-48
4.5.2.1	Construction.....	4-48
4.5.2.2	Operation.....	4-50
4.5.3	Lake Charles CCS Project.....	4-51
4.5.3.1	CO ₂ Capture and Compression Facilities.....	4-51
4.5.3.2	CO ₂ Pipeline.....	4-51
4.5.3.3	Alternative Route B.....	4-52
4.5.3.4	West Hastings Research MVA Program.....	4-53
4.6	Biological Resources.....	4-55
4.6.1	Factors Considered for Assessing Impacts.....	4-55
4.6.2	LCCE Gasification Plant (Connected Action).....	4-55
4.6.2.1	Construction.....	4-55
4.6.2.2	Operation.....	4-58
4.6.3	Lake Charles CCS Project.....	4-59
4.6.3.1	CO ₂ Capture and Compression Facilities.....	4-59

4.6.3.2	CO ₂ Pipeline.....	4-59
4.6.3.3	Alternative Route B	4-61
4.6.3.4	West Hastings Research MVA Program.....	4-61
4.7	Cultural Resources	4-63
4.7.1	Factors Considered for Assessing Impacts	4-63
4.7.2	LCCE Gasification (Connected Action)	4-65
4.7.2.1	Construction.....	4-65
4.7.2.2	Operation.....	4-65
4.7.3	Lake Charles CCS Project	4-65
4.7.3.1	CO ₂ Capture and Compression Facilities	4-65
4.7.3.2	CO ₂ Pipeline.....	4-65
4.7.3.3	West Hastings Research MVA	4-66
4.7.4	Compliance with Section 106 of the NHPA.....	4-66
4.7.4.1	Definition of Area of Potential Effects	4-66
4.7.4.2	Section 106 Consultation	4-67
4.8	Land Use	4-71
4.8.1	Factors Considered for Assessing Impacts	4-71
4.8.2	LCCE Gasification (Connected Action)	4-71
4.8.2.1	Construction.....	4-71
4.8.2.2	Operations	4-74
4.8.3	Lake Charles CCS Project	4-75
4.8.3.1	CO ₂ Capture and Compression Facilities	4-75
4.8.3.2	CO ₂ Pipeline.....	4-75
4.8.3.3	Alternative Route B	4-78
4.8.3.4	West Hastings Research MVA	4-78
4.9	Socioeconomics and Environmental Justice.....	4-80
4.9.1	Factors Considered for Assessing Impacts	4-80
4.9.2	LCCE Gasification Plant (Connected Action).....	4-81
4.9.2.1	Population and Housing Impacts	4-81
4.9.2.2	Economy and Income	4-82
4.9.2.3	Local Government Revenues and Expenditures	4-83
4.9.2.4	Community Services.....	4-84
4.9.2.5	Environmental Justice.....	4-85
4.9.3	Lake Charles CCS Project	4-85
4.9.3.1	CO ₂ Capture and Compression Facilities	4-85
4.9.3.2	CO ₂ Pipeline.....	4-85
4.9.3.3	West Hastings Research MVA	4-89
4.10	Traffic and Transportation	4-91
4.10.1	Factors Considered for Assessing Impacts	4-91
4.10.2	LCCE Gasification (Connected Action)	4-93
4.10.2.1	Construction.....	4-93
4.10.2.2	Operation.....	4-100
4.10.3	Lake Charles CCS Project	4-100
4.10.3.1	CO ₂ Capture and Compression Facilities	4-100
4.10.3.2	CO ₂ Pipeline.....	4-100
4.10.3.3	West Hastings Research MVA	4-102

4.11	Noise	4-103
4.11.1	Factors Considered for Assessing Impacts	4-103
4.11.2	LCCE Gasification (Connected Action)	4-106
4.11.2.1	Construction	4-106
4.11.2.2	Operation	4-112
4.11.3	Lake Charles CCS Project	4-113
4.11.3.1	CO ₂ Capture and Compression Facilities	4-113
4.11.3.2	CO ₂ Pipeline	4-114
4.11.3.3	West Hastings Research MVA	4-117
4.12	Waste Management	4-119
4.12.1	Factors Considered for Assessing Impacts	4-119
4.12.2	LCCE Gasification (Connected Action)	4-120
4.12.2.1	Construction	4-120
4.12.2.2	Operation	4-121
4.12.3	Lake Charles CCS Project	4-124
4.12.3.1	CO ₂ Capture and Compression Facilities	4-124
4.12.3.2	CO ₂ Pipeline	4-124
4.12.3.3	West Hastings Research MVA	4-125
4.13	Materials	4-127
4.13.1	Factors Considered for Assessing Impacts	4-127
4.13.2	LCCE Gasification (Connected Action)	4-128
4.13.2.1	Construction	4-128
4.13.2.2	Operation	4-130
4.13.3	Lake Charles CCS Project	4-135
4.13.3.1	CO ₂ Capture and Compression Facilities	4-135
4.13.3.2	Lake Charles CCS CO ₂ Pipeline	4-136
4.13.3.3	West Hastings Research MVA	4-140
4.13.4	Summary of Impacts	4-140
4.14	Human Health and Safety	4-142
4.14.1	Factors Considered for Assessing Impacts	4-142
4.14.2	LCCE Gasification Plant	4-143
4.14.2.1	Construction	4-143
4.14.2.2	Operation	4-144
4.14.3	Lake Charles CCS Project	4-145
4.14.3.1	CO ₂ Capture and Compression Facilities	4-145
4.14.3.2	CO ₂ Pipeline	4-145
4.14.3.3	West Hastings Research MVA Program	4-147
4.15	Accident Analyses	4-149
4.15.1	Factors Considered for Assessing Impacts	4-149
4.15.2	LCCE Gasification Plant	4-155
4.15.2.1	Storage, Handling, and Transport	4-156
4.15.2.2	Operation	4-165
4.15.3	Lake Charles CCS Project	4-167
4.15.3.1	CO ₂ Capture and Compression Facilities	4-168
4.15.3.2	CO ₂ Pipeline	4-169
4.15.4	Intentional Destructive Acts	4-172

4.16	Impacts of No Action.....	4-175
4.16.1	No Action Sub-Alternative 1	4-175
4.16.2	No Action Sub-Alternative 2	4-176
5.	Potential Cumulative Effects	5-1
5.1	Approach and Analytical Perspective.....	5-1
5.1.1	Background.....	5-1
5.1.2	Geographic Area of Project Impacts.....	5-1
5.1.3	Reasonably Foreseeable Future Development: Specific Actions and Trends.....	5-2
5.1.4	Analysis Methodology	5-5
5.2	Cumulative Effects of High Importance	5-18
5.2.1	Air Quality	5-18
5.2.2	Climate Change.....	5-18
5.2.2.1	Climate Change, GHGs, and the LCCE Gasification Plant....	5-22
5.2.3	Surface Water.....	5-23
5.3	Cumulative Effects of Intermediate Importance.....	5-24
5.3.1	Geology and Soils	5-25
5.3.2	Biology.....	5-26
5.3.3	Traffic and Transportation	5-27
5.3.4	Socioeconomics	5-28
6.	Applicable Regulatory Requirements and Permits	6-1
6.1	Federal Laws and Regulations	6-1
6.2	Applicable Executive Orders	6-5
6.3	State Laws, Regulations, and Agreements.....	6-6
6.4	Permits and Approval Status.....	6-8
7.	Irreversible and Irretrievable Commitment of Resources.....	7-1
7.1	Relationship Between Short-term Uses of the Environment and Long-term Productivity.....	7-2
8.	References	8-1
9.	Distribution List	9-1
10.	List of Preparers	10-1

- A Environmental Synopsis for the Lake Charles CCS Project**
- B US Army Corps of Engineers Permits issued to the Port of Lake Charles for the Gasification Site**
- C USFWS Consultations**
- D Section 106 Consultations**
- E Floodplain and Wetland Assessment**
- F Accident Analysis and ALOHA Modeling**
- G Denbury Lake Charles Pipeline Lateral 16" CO₂ Pipeline Public Risk and Pipeline Design Narrative**

List of Tables

<u>Table</u>		<u>Page</u>
S-1	Resource Consumption for Operation of LCCE Gasification and Lake Charles CCS CO ₂ Capture and Compression.....	16
S-2	Major Outputs, Discharges, and Wastes from Operation of the LCCE Gasification Plant and Lake Charles CO ₂ Capture and Compression (annual unless otherwise stated)	17
S-3	Summary of Unavoidable Environmental Impacts.....	28
S-4	Regional Projects Identified for Consideration in the Cumulative Impacts Analysis.....	38
2.3-1	Major Components of a Typical Class II Well Application	2-22
2.3-2	Proposed MVA Activities at West Hastings Research MVA Program (as of 10/2012).....	2-26
2.4-1	Hydrostatic Test Water Estimates for Each LCCE Gasification Plant Pipeline	2-31
2.4-2	Wastes Generated during Construction of LCCE Gasification and Lake Charles CO ₂ Capture and Compression.....	2-33
2.5-1	Resource Consumption for Operation of LCCE Gasification and Lake Charles CCS CO ₂ Capture (annual unless otherwise specified)	2-37
2.5-2	Storage of Water Treatment Chemicals for Operation of LCCE Gasification and Lake Charles CO ₂ Capture and Compression.....	2-41
2.5-3	Major Outputs, Discharges, and Wastes from Operation of the LCCE Gasification Plant and Lake Charles CO ₂ Capture and Compression (annual unless otherwise stated)	2-42
3.2-1	Precipitation and Temperature (T) Data for Lake Charles, Louisiana, Airport (1971-2000).....	3-3
3.2-2	Precipitation and Temperature (T) Data for Alvin, Texas (1971-2000).....	3-4
3.2-3	Active Ambient Air Quality Monitors	3-5
3.2-4	2008 Ambient Air Quality Data for Calcasieu Parish	3-5
3.2-5	Criteria Pollutant Emissions in Calcasieu Parish, Louisiana (2008)	3-6

3.2-6	Criteria Pollutant Emissions in Brazoria County, Texas (2008).....	3-7
3.3-1	Soil Series for Project Areas in Calcasieu Parish, Louisiana.....	3-16
3.3-2	Soil Series for Project Areas in Hastings Oil Field, Texas	3-16
3.4-1	Surface Water Quality and Use Designation	3-30
3.4-2	Wetlands within the Proposed CO ₂ Pipeline ROW	3-36
3.6-1	Vegetation and Land Cover Along the Water Supply and Hydrogen Pipelines	3-43
3.6-2	Vegetation and Land Cover Crossed by the CO ₂ Pipeline.....	3-43
3.6-3	Common Fauna in the Northern Humid Gulf Coastal Prairies Ecoregion	3-45
3.6-4	Finfish Species Potentially Occurring in the Northern Humid Gulf Coastal Prairie Ecoregion	3-46
3.6-5	Federal and State Protected Species Potentially Occurring in the Area	3-48
3.6-6	Federal Protected Species Potentially Occurring in Brazoria County	3-49
3.8-1	Land Use within a 1-Mile Radius of the LCCE Gasification Plant and Lake Charles CCS Project	3-58
3.8-2	Land Use within a 1-Mile Buffer along the Water Supply and Hydrogen Pipelines	3-64
3.8-3	Land Use within a 1-Mile-Wide Buffer along the CO ₂ Pipeline.....	3-65
3.8-4	Residences within 50 feet of the Construction Workspace of the Proposed CO ₂ Pipeline.....	3-66
3.9-1	Historic and Current Population (2000, 2010).....	3-67
3.9-2	Total Housing Units (2000, 2010)	3-71
3.9-3	Detailed Housing Statistics	3-71
3.9-4	Historic and Current Population (2000, 2010).....	3-72
3.9-5	Total Housing Units (2000, 2010)	3-72
3.9-6	Detailed Housing Statistics	3-72
3.9-7	Employment by Sector (2009)	3-73
3.9-8	Annual Average Labor Force Statistics (2010)	3-74

3.9-9	Income Statistics	3-74
3.9-10	Employment by Sector (2009)	3-74
3.9-11	Annual Average Labor Force Statistics (2010)	3-75
3.9-12	Income Statistics	3-75
3.9-13	Total Assessed Value (billions) (2007, 2008, 2009, 2010).....	3-76
3.9-14	Local Government Revenues (1,000s) (FY 2010).....	3-76
3.9-15	Local Government Expenditures (1,000s) (FY 2010)	3-77
3.9-16	Total Taxable Assessed Value and Property Tax Rates (2010).....	3-77
3.9-17	Local Government Revenues, by Source, for Fiscal Year Ending Sept. 30, 2010 (in 1,000s)	3-77
3.9-18	Local Government Expenditures, by Expense, for Fiscal Year Ending September 30, 2011 (in 1,000s)	3-78
3.9-19	Percent Minority and Low-Income Characteristics Within the Study Area	3-80
3.9-20	Percent Minority and Low-Income Characteristics within of the Study Area of the Proposed CO ₂ Pipeline.....	3-81
3.9-21	Percent Minority and Low Income Characteristics, Alternative CO ₂ Pipeline	3-83
3.9-22	Percent Minority and Low-Income Characteristics: West Hastings Research MVA Site	3-85
3.10-1	2010 Average Annual Daily Traffic (AADT) Counts	3-91
3.10-2	Level of Service Designations	3-92
3.10-3	2012 Estimated Level of Service on Roadways During Construction	3-92
3.11-1	Common Noise Levels.....	3-95
3.12-1	Industrial, Municipal, and Hazardous Waste Facilities Available for Use by the LCCE Gasification Plant.....	3-99
3.12-2	EPA-Regulated Contaminated Sites along the Proposed Pipeline Route.....	3-99
3.13-1	Occupational Injury and Fatality Rate Data For Related Industries	3-100
3.13-2	Population Characteristics of Sensitive Receptors Within 1 Mile of the LCCE Gasification Plant.....	3-102

3.13-3	Population Characteristics of Sensitive Receptors Within 0.5 Miles of the Proposed CO ₂ Pipeline.....	3-103
4.2-1	Construction Emissions LCCE Gasification Plant and Lake Charles CSS Project CO ₂ Capture and Compression Facilities (tons per year).....	4-3
4.2-2	Construction Emissions LCCE Gasification Water and Hydrogen Pipeline (tons)	4-4
4.2-3	Operation Criteria Pollutant Emissions for the LCCE Gasification Plant and Lake Charles CSS Project CO ₂ Capture and Compression Facilities (tons per year)	4-6
4.2-4	Operation Toxic Air Pollutant Emissions LCCE Gasification and Lake Charles CSS Project CO ₂ Capture and Compression Facilities (tons per year)	4-6
4.2-5	Air Dispersion Modeling Results LCCE Gasification.....	4-6
4.2-6	Indirect Emissions from Electricity Use in the CO ₂ Capture and Compression Facility	4-9
4.2-7	CO ₂ Pipeline Construction Emissions (tons).....	4-9
4.2-8	Calcasieu Parish Ozone Maintenance Plan Emission Budget (tons per day)	4-12
4.2-9	Comparison of 2014 Calcasieu Parish Ozone Maintenance Plan Emission Budget with LCCE Gasification and Lake Charles CSS Project Construction Emissions (tons per day)	4-12
4.2-10	Summary of Potential Impacts on Air Quality and Minimization Measures for LCCE Gasification Plant and Off-site Activities	4-12
4.2-11	Summary of Potential Impacts on Air Quality and Minimization Measures for Lake Charles CCS Project.....	4-13
4.3-1	Prime Farmland Soil Designations in Water Supply and Hydrogen Pipeline Routes (95-foot-wide buffer)	4-17
4.3-2	Prime Farmland Soil Designations in CO ₂ Pipeline Route (95-foot-wide buffer)	4-19
4.3-3	Prime Farmland Soil Designations in Alternative B Route (95-foot-wide buffer)	4-19
4.3-4	Summary of Impacts on Geology and Soils and Minimization Measures for LCCE Gasification Plant and Off-site Activities	4-23

4.3-5	Summary of Potential Impacts on Geology and Soils and Minimization Measures for Lake Charles CCS Project	4-23
4.4-1	Surface Water Crossings of the Water Supply Pipeline	4-28
4.4-2	Surface Water Crossings of the Hydrogen Pipeline	4-28
4.4-3	Potential Wetland Impacts by Segments for the Water Supply Pipeline.....	4-33
4.4-4	Potential Wetland Impacts by Segment for the Hydrogen Pipeline	4-33
4.4-5	Effluent Limitations for the LCCE Gasification Plant for Outfall 001 and 002.....	4-35
4.4-6	Surface Water Crossings of the CO ₂ Pipeline.....	4-37
4.4-7	Hydrostatic Test Water Information for the Lake Charles CO ₂ Pipeline	4-39
4.4-8	Collocation of the Proposed Lake Charles Pipeline Lateral Project with Existing Easements and Rights-of-Way	4-40
4.4-9	Summary of Potential Surface Water, Wetland, and Floodplain Impacts of the Proposed CO ₂ Pipeline Route	4-41
4.4-10	Total Wetland Impacts From the CO ₂ Pipeline to be Offset by Mitigation.....	4-42
4.4-11	Summary of Potential Surface Water, Wetland, and Floodplain Impacts of the Alternative CO ₂ Pipeline Route Compared to the Proposed Route, acres	4-43
4.4-12	Summary of Potential Impacts on Surface Water, Floodplains, and Wetlands and Minimization Measures for LCCE Gasification Plant and Off-site Activities.....	4-46
4.4-13	Summary of Potential Impacts on Surface Water, Floodplains, and Wetlands and Minimization Measures for Lake Charles CCS Project.....	4-47
4.5-1	Summary of Potential Impacts on Groundwater and Minimization Measures for LCCE Gasification Plant and Off-site Activities.....	4-54
4.5-2	Summary of Potential Impacts on Groundwater and Minimization Measures for Lake Charles CCS Project	4-54
4.6-1	Vegetation Impacts with the Water Supply and Hydrogen Pipeline Routes (acres).....	4-57
4.6-2	Vegetation Impacts for the CO ₂ Pipeline (acres).....	4-59

4.6-3	Summary of Potential Impacts on Biological Resources and Minimization Measures for LCCE Gasification Plant and Off-site Activities.....	4-62
4.6-4	Summary of Potential Impacts on Biological Resources and Minimization Measures for Lake Charles CCS Project	4-62
4.7-1	Criteria for the Determination of Adverse Effects on Historic Properties.....	4-64
4.7-2	Federally Recognized Native American Tribes Consulted for the Proposed Action.....	4-69
4.7-3	Summary of Potential Impacts on Cultural Resources and Minimization Measures for LCCE Gasification Plant and Off-site Activities.....	4-70
4.7-4	Summary of Potential Impacts on Cultural Resources and Minimization Measures for Lake Charles CCS Project	4-70
4.8-1	Land Cover/Land Use Impacts Associated with the Water Supply Pipeline Route.....	4-73
4.8-2	Land Cover/Land Use Impacts Associated with the Hydrogen Pipeline Route.....	4-73
4.8-3	Land Cover/Land Use Impacts Associated with the Proposed CO ₂ Pipeline Route.....	4-76
4.8-4	Land Cover/Land Use Impacts Associated with the Alternate Pipeline Route.....	4-78
4.8-5	Summary of Potential Impacts on Land Use and Minimization Measures for LCCE Gasification Plant and Off-site Activities	4-79
4.8-6	Summary of Potential Impacts on Land Use and Minimization Measures for Lake Charles CCS Project.....	4-79
4.9-1	Summary of Potential Impacts on Socioeconomics and Environmental Justice and Minimization Measures for LCCE Gasification Plant and Off-site Activities	4-90
4.9-2	Summary of Potential Impacts on Socioeconomics and Environmental Justice and Minimization Measures for Lake Charles CCS Project.....	4-91
4.10-1	LOS Criteria for Basic Freeway Segments at 70 mph.....	4-92
4.10-2	LOS Criteria for Multi-Lane Freeway Segments at 55 mph.....	4-93
4.10-3	LOS Criteria for Two-Lane Highway Segments at 45 mph	4-93

4.10-4	Peak One-Way Commuter, Shuttle, and Delivery Trip Distributions During Construction (per day)	4-94
4.10-5	Projected LOS of I-10 Segments during Construction using the HCM 2012 Basic Freeway Operational Methodology	4-95
4.10-6	Projected LOS of Local Multi Lane Highways during Construction Using the HCM Multi-Lane Highway Operational Methodology	4-95
4.10-7	Projected LOS of Local Two Lane Highway Segments during Construction Using the HCM Two-Lane Highway Operational Methodology	4-97
4.10-8	Summary of Projected LOS of Transportation Resources during Peak Construction of LCCE Gasification Plant and the Lake Charles CCS Project Capture and Compression Facilities	4-98
4.10-9	Summary of Potential Impacts on Traffic and Transportation and Minimization Measures for LCCE Gasification Plant and Off-site Activities	4-102
4.10-10	Summary of Potential Impacts on Traffic and Transportation and Minimization Measures for Lake Charles CCS Project.....	4-103
4.11-1	HUD Site Acceptability Standards	4-104
4.11-2	Site Preparation Noise Levels at Various Distances.....	4-107
4.11-3	Construction Noise Levels at Various Distances.....	4-107
4.11-4	Construction Noise from Typical Pipeline Construction Equipment and Activities.....	4-109
4.11-5	Typical HDD Equipment for Pipeline Construction.....	4-110
4.11-6	Estimated Sound Level Contribution of the Planned HDD Crossings for the Water Supply Pipeline	4-110
4.11-7	Estimated Sound Level Contribution of the HDD Crossings for the Hydrogen Pipeline	4-111
4.11-8	Typical Process Equipment Sound Levels.....	4-112
4.11-9	Equipment Sound Power Level Calculation for LCCE Gasification Plant to Achieve 58 dBA.....	4-113
4.11-10	Commercial and Residential Areas within 50 Feet of the Construction Workspace of the Proposed CO ₂ Pipeline	4-114

4.11-11	Estimated Sound Level Contribution of the Planned HDD Sites	4-115
4.11-12	Noise from Drill Rig Truck at Various Distances	4-118
4.11-13	Summary of Potential Noise Impacts and Minimization Measures for LCCE Gasification Plant and Off-site Activities.....	4-118
4.11-14	Summary of Potential Noise Impacts and Minimization Measures for Lake Charles CCS Project	4-119
4.12-1	Wastes Generated during Construction and Management Methods.....	4-120
4.12-2	Wastes Generated during Operation and Management Methods (annual unless otherwise stated)	4-122
4.12-3	Summary of Potential Waste Impacts and Minimization Measures for LCCE Gasification Plant and Off-site Activities.....	4-126
4.12-4	Summary of Potential Waste Impacts and Minimization Measures for Lake Charles CCS Project	4-127
4.13-1	Resource Consumption and Storage Capacity During Operation of the LCCE Gasification Plant.....	4-130
4.13-2	Products Generated During Operation of the LCCE Gasification Plant.....	4-131
4.13-3	Hazardous Materials Used During Operation of the Lake Charles CO ₂ Capture and Compression Facilities.	4-136
4.13-4	Summary of Potential Impacts on Materials and Minimization Measures for LCCE Gasification Plant and Off-site Activities	4-141
4.13-5	Summary of Potential Impacts on Materials and Minimization Measures for Lake Charles CCS Project.....	4-141
4.14-1	Summary of Potential Impacts on Human Health and Safety and Minimization Measures for LCCE Gasification Plant and Off-site Activities.....	4-148
4.14-2	Summary of Potential Impacts on Human Health and Safety and Minimization Measures for Lake Charles CCS Project.....	4-148
4.15-1	Chemicals of Potential Concern.....	4-150
4.15-2	Properties and Hazards Associated with Chemicals of Concern	4-151
4.15-3	Incident Rate and Accident Categories for Transport and Storage.....	4-156

4.15-4	Summary of Estimated Incident Probabilities for the LCCE Gasification Plant for Each Mode of Transport and Storage	4-157
4.15-5	Estimated Consequences of Aqueous Ammonia Release Scenarios	4-160
4.15-6	Estimated Consequences of Chlorine Release Scenarios	4-161
4.15-7	Estimated Consequences of Methanol Release.....	4-163
4.15-8	Estimated Consequences of Hydrogen Sulfide, Carbon Monoxide, and Hydrogen Release Scenarios for the LCCE Gasification Plant.....	4-166
4.15-9	Estimated Consequences of Hydrogen Sulfide, Carbon Monoxide, and Propylene Releases for Lake Charles CO ₂ Capture and Compression	4-169
4.15-10	Lake Charles CCS CO ₂ Pipeline Specifications	4-170
4.15-11	CO ₂ Pipeline , Hazardous Liquids, and Natural Gas Pipeline Incident Rate (1992 to 2011).....	4-170
4.15-12	Pipeline Segment Exposure Distance Summary.....	4-171
4.16-1	Comparison of No Action Alternatives with Environmental Impacts of the Proposed Project and Connected Action.....	4-177
5.1-1	Regional Projects Identified for Consideration in the Cumulative Impacts Analysis.....	5-6
5.1-2	Summary of Unavoidable Environmental Impacts.....	5-8
5.1-3	Indicators of Importance for Cumulative Effects Issues.....	5-15
5.1-4	Cumulative Effects Matrix.....	5-16
5.2-1	Summary of Surface Water Impacts for the Proposed Project and Connected Action.....	5-23
5.2-2	Summary of Cumulative Impacts on Wetlands	5-24
5.3-1	Summary of Potential Cumulative Impacts on Forest Habitat	5-27
6.3-1	Applicable Louisiana State Laws, Regulations, and Agreements	6-7
6.3-2	Applicable Texas State Laws, Regulations, and Agreements.....	6-8
6.4-1	Required Federal and State Permits and Approval Status	6-9

This page left blank intentionally.

List of Figures

<u>Figure</u>		<u>Page</u>
S-1	Lake Charles CCS Project Overall Location, Texas and Louisiana	5
S-2	Lurgi Rectisol [®] Acid Gas Removal System	9
S-3	Alternative and Preferred Pipeline Routes.....	11
1.1-1	Project Locations for ICCS Technology Area 1	1-2
1.5-1	NEPA Process Flow Chart.....	1-7
2.2-1	Lake Charles CCS Project Overall Location, Texas and Louisiana	2-3
2.3-1	LCCE Gasification Plan (Connected Action) Major Components	2-5
2.3-2	LCCE Gasification Plant Layout	2-9
2.3-3	LCCE Gasification Process Flow Diagram	2-11
2.3-4	Lurgi Rectisol [®] Acid Gas Removal System	2-15
2.3-5	Alternative and Preferred Pipeline Routes.....	2-17
2.3-6	Typical EOR Components and Process	2-21
2.3-7	Hastings Field Development Plan and Existing Utilities.....	2-23
2.5-1	LCCE Gasification Storm Water and Wastewater Outfalls.....	2-39
3.3-1	Regional Physiography for the Lake Charles CCS Project (Proposed Project) and LCCE Gasification Project (Connected Action)	3-9
3.3-2	Stratigraphic and Hydrostratigraphic Units in Southwestern Louisiana.....	3-10
3.3-3	Stratigraphic and Hydrostratigraphic Units in the Gulf Coast Basin in Texas	3-11
3.3-4	Cross-Section C-C' in the Gulf Coast Basin in Texas	3-13
3.3-5	Seismic Hazard Map for the Lake Charles CCS Project (Proposed Project) and LCCE Gasification Project (Connected Action)	3-15
3.3-6	Soil Series Map for LCCE Gasification Project and CO ₂ Capture and Compression Facilities.....	3-17

3.3-7	Soil Series Map for the Proposed CO ₂ Pipeline Route and Alternative	3-19
3.3-8	Soil Series Map for the Research MVA Site	3-21
3.4-1	Calcasieu River Watershed Location.....	3-25
3.4-2	Waterbodies and FEMA Floodplains.....	3-27
3.4-3	FEMA Floodplains within Vicinity of CO ₂ Injection and Research MVA	3-31
3.5-1	Operational, Demand, and Emergency Wells in the Chicot Aquifer Within 2 Miles of the CO ₂ Injection and Research MVA Site	3-41
3.8-1-A	Land Use Types, Calcasieu Parish, Louisiana	3-60
3.8-1-B	Land Use Types, Calcasieu Parish, Louisiana	3-62
3.8-2	Land Use Types, Brazoria County, Texas	3-69
3.10-1	LCCE Gasification Project (Connected Action) Roadway Functional Classifications and 2010 Traffic Counts.....	3-89
3.11-1	Sound Levels.....	3-96
4.4-1	Horizontal Direction Drilling Waterbody Crossing, Typical Construction.....	4-30
4.15-1	2010 Census Tracts and Blocks along the Proposed CO ₂ Pipeline	4-173
5.1-1	Other Projects Surrounding the LCCE Gasification Project.....	5-3

Acronyms and Abbreviations

°F	degrees Fahrenheit
µg/m ³	micrograms per cubic meter
AADT	annual average daily traffic
ACGIH	American Conference of Governmental Industrial Hygienists
ACHP	Advisory Council on Historic Preservation
AGR	acid gas removal
AIRFA	American Indian Religious Freedom Act of 1978, as amended
APE	area of potential effects
Ar	argon
ARPA	Archeological Resources Protection Act of 1979, as amended
ASU	air separation unit
ATWS	additional temporary workspaces
AZMI	above-zone monitoring interval
BCGCD	Brazoria County Groundwater Conservation District
BEG	(Texas) Bureau of Economic Geology
bgs	below ground surface
BMPs	best management practices
CCS	carbon capture and sequestration
CCSP	Climate Change Science Program
CEQ	Council on Environmental Quality
CFR	Code of Federal Regulations
CH ₄	methane
CO	carbon monoxide
CO ₂	carbon dioxide
CO ₂ e	carbon dioxide equivalent
COC	community of comparison

COS	carbonyl sulfide
CSM	conceptual site model
CWA	Clean Water Act
CY	cubic yard
dB	decibel
dba	A-weighted decibel
Denbury	Denbury Onshore, LLC
DO	dissolved oxygen
DOE	U.S. Department of Energy
DOT	(U.S.) Department of Transportation
EFH	Essential Fish Habitat
EIS	Environmental Impact Statement
EOR	enhanced oil recovery
EPA	(U.S.) Environmental Protection Agency
EPCRA	Emergency Planning and Community Right-to-Know Act
ESA	Endangered Species Act
FEMA	Federal Emergency Management Agency
FLAG	Federal Land Managers AQRV Workgroup
FLM	Federal Land Manager
FOA	funding opportunity announcement
FR	Federal Register
ft ³ /yr	cubic feet per year
GHG	greenhouse gas
GIS	Geographic Information System
gpm	gallons per minute
GTL	gas-to-liquid
H ₂ S	hydrogen sulfide
HAPs	hazardous air pollutants
HDD	horizontal directional drill
HUC	Hydrological Unit Code
HUD	(U.S.) Department of Housing and Urban Development
ICCS	Industrial Carbon Capture and Sequestration

IMCAL	Imperial Calcasieu Regional Planning and Development Commission
ISCST	Industrial Source Complex Short Term
LAAQS	Louisiana Ambient Air Quality Standards
Lake Charles CCS project	Leucadia Energy's Lake Charles Carbon Capture and Sequestration project
LAOSCO	Louisiana Oil Spill Coordinator's Office
LCCE	Lake Charles Clean Energy, LLC
LDEQ	Louisiana Department of Environmental Quality
LDOTD	Louisiana Department of Transportation and Development
LDWF	Louisiana Department of Wildlife and Fisheries
Leucadia	Leucadia Energy, LLC
LNG	liquefied natural gas
LOS	level of service
LPDES	Louisiana Pollutant Discharge Elimination System
LULC	Louisiana Land Use and Land Cover
MBTA	Migratory Bird Treatment Act
MCSF	million cubic feet per second
mg/L	milligrams per liter
mg/m ³	milligrams per cubic meter
MGD	million gallons per day
MMSCFD	million standard cubic feet per day
MOA	Memorandum of Agreement
MSA	Metropolitan Statistical Area
MSL	mean sea level
MVA	monitoring, verification, and accounting
MW	megawatts
N ₂	nitrogen
NAAQS	National Ambient Air Quality Standards
NAGPRA	Native American Graves Protection and Repatriation Act
NEI	National Emission Inventory
NEPA	National Environmental Policy Act of 1969, as amended

NH ₃	ammonia
NHL	National Historic Landmark
NHPA	National Historic Preservation Act of 1966, as amended
NIOSH	National Institute of Occupational Safety and Health
NO ₂	nitrogen dioxide
NOAA	National Oceanic and Atmospheric Administration
NOI	Notice of Intent
NO _x	nitrogen oxides
NPDES	National Pollution Discharge Elimination System
NRHP	National Register of Historic Places
NSA	noise-sensitive area
NWI	National Wetlands Inventory
NWP	Nationwide Permit
NWRC	National Wetlands Research Center
O.D.	outside diameter
O ₂	oxygen
O ₃	ozone
OPS	Office of Pipeline Safety
OSHA	Occupational Safety and Health Administration
P&A	plugged and abandoned
PAHs	polycyclic aromatic hydrocarbons
PCBs	polychlorinated biphenyls
PCN	Pre-Construction Notification
PHA	peak horizontal acceleration
PHMSA	Pipeline and Hazardous Materials Safety Administration
PM ₁₀	particulate matter smaller than 10 microns in diameter
PM _{2.5}	particulate matter smaller than 2.5 microns in diameter
ppm	parts per million
psig	pounds per square inch gauge
RRC	(Texas) Railroad Commission
RCRA	Resource Conservation and Recovery Act
RECAP	Risk Evaluation/Corrective Action Program

Recovery Act	American Recovery and Reinvestment Act of 2009
RFT	repeat formation test
ROI	region of influence
ROW	right-of-way
SAL	State Archaeological Landmark
SDWA	Safe Drinking Water Act
SHPO	State Historic Preservation Office(r)
SIP	state implementation plan
SO ₂	sulfur dioxide
SPCC	Spill Prevention, Control, and Countermeasures
SPL	sound pressure level
SRA	Sabine River Authority
SRD	Sabine River Diversion
SWPPP	Storm Water Pollution Prevention Plan
TA	temporarily abandoned
TAP	toxic air pollutant
TCEQ	Texas Commission on Environmental Quality
TCP	traditional cultural property
TDS	total dissolved solids
THC	Texas Historical Commission
TMDLs	total maximum daily loads
TPD	tons per day
TPDES	Texas Pollution Discharge Elimination System
TPY	tons per year
TRIP	Toxic Release Inventory Program
TXNDD	Texas Natural Diversity Database
UIC	underground injection control
UNEP	United Nations Environment Programme
USACE	U.S. Army Corps of Engineers
USC	United States Code
USCB	United States Census Bureau
USDW	underground source of drinking water

USFWS	U.S. Fish and Wildlife Service
USGM	U.S. Gulf of Mexico
USGS	U.S. Geological Survey
VOCs	volatile organic compounds
VSP	vertical seismic profile
WMO	World Meteorological Organization
WMP	Waste Management Plan
WSA	wet sulfuric acid
WSA	William Self Associates, Inc.
WSRC	Wild and Scenic Rivers Council
WWTP	wastewater treatment plant
ZLD	zero liquid discharge

Glossary

■ General

Industrial Carbon Capture and Sequestration (ICCS): Refers to a program of cost-shared collaborations between the federal government, through the DOE’s National Energy Technology Laboratory, and industry to increase investment in industrial carbon capture and sequestration projects. Under the ICCS funding opportunity, industrial firms proposed projects to meet their needs and those of their customers while furthering the national goals and objectives of the program.

Leucadia Energy, LLC (Leucadia): The Applicant awarded funding under the ICCS program. Leucadia Energy, LLC is an indirect, wholly owned subsidiary of Leucadia National Corporation. “Leucadia” is used throughout this document to refer to the Applicant and related entities, including Lake Charles Clean Energy.

Lake Charles Clean Energy, LLC (LCCE): Developer of the Lake Charles Clean Energy gasification plant that is the industrial source of CO₂ for the Lake Charles CCS project. Lake Charles Clean Energy, LLC is an indirect, wholly owned subsidiary of Leucadia National Corporation.

Lake Charles Clean Energy Gasification plant (LCCE Gasification plant): The proposed petroleum coke gasification facility that would produce methanol, hydrogen gas, and sulfuric acid. The facility would be located on an approximately 70-acre parcel of land in southern Calcasieu Parish, Louisiana, adjacent to the Lake Charles Harbor and Terminal District (Port of Lake Charles), on the west bank of the Calcasieu River.

Lake Charles CCS project: The Lake Charles Carbon Capture and Sequestration project, which would capture CO₂ from the LCCE Gasification plant and transport the CO₂ via a new connector pipeline to Denbury’s existing Green Pipeline, and jointly fund a research program for monitoring, verifying, and accounting for approximately 1 million tons per year of CO₂ injected for purposes of enhanced oil recovery at the West Hastings oil field, located south of Houston, Texas.

Denbury Onshore, LLC (Denbury): A subcontractor to the Applicant for funding under the ICCS program. Denbury is an independent oil and gas company and the largest oil and natural gas producer in both Mississippi and Montana. Denbury operates the largest reserves of carbon dioxide (CO₂) used for tertiary oil recovery east of the Mississippi River.

Green Pipeline: An approximately 325-mile-long, 24-inch-diameter CO₂ pipeline that extends westward from near Donaldsonville, Louisiana (south of Baton Rouge), to the West Hastings oil field in Texas (south of Houston). The Green Pipeline transports up to 800 million standard cubic feet per day (MMSCFD) of CO₂, which comes from both anthropogenic (man-made)

sources and natural sources (from the Jackson Dome, an underground formation containing natural CO₂).

geologic sequestration: A promising GHG mitigation approach that involves placing CO₂ where it has a high probability of being permanently stored. Storage is accomplished by injecting dense phase CO₂ through deep wells into deep geologic formations typically greater than 2,500 feet underground and isolated from the ground surface and drinking water sources by impermeable layers of rock. Underground formations typically considered for geologic sequestration and include: mature oil and gas reservoirs; deep saline formations; deep unmineable coal seams; oil and gas rich organic shales, and basalt formations.

Hastings oil field: A historical oil production area, including West Hastings and East Hastings, of approximately 25 square miles between Alvin and Pearland, Texas, where oil reserves are recovered with CO₂ enhanced oil recovery from sands in the Oligocene-age Marginlina, Frio, and Vicksburg formations, ranging in depths from 5,000 to 10,000 feet below ground surface (bgs). Denbury owns and operates an interest in the Hastings oil field.

West Hastings research monitoring, verification, and accounting (MVA) program: A program aimed at providing an accurate accounting of approximately 1 million tons of stored CO₂ per year and a high level of confidence that the CO₂ injected during the existing EOR operations will remain sequestered permanently in Fault Blocks B and C in the West Hastings oil field. The program would be implemented by Denbury and the Texas Bureau of Economic Geology (BEG) and would include monitoring for possible CO₂ migration through strata above the target EOR zones, particularly in an aquifer above the main cap rock layer, in shallower aquifers that could serve as underground sources of drinking water, and in soil at the ground surface.

purpose and need: A statement of goals and objectives fulfilled by taking action. It refers to the underlying reasons why an agency must take action and establishes the boundaries for reasonable alternatives that the agency must consider.

connected actions: Actions that are “closely related” to the proposed action and alternatives. Connected actions automatically trigger other actions, cannot or will not proceed unless other actions have been taken previously or simultaneously, or are interdependent parts of a larger action and depend on the larger action for their justification.

■ Air Quality

air quality: The cleanliness of the air as measured by the levels of pollutants relative to standards or guideline levels established to protect human health and welfare. Air quality is often expressed in absolute terms for individual criteria pollutants (e.g., measured air concentrations of a pollutant equaling or exceeding a specified value over a particular span of time or with the particular frequency) or in relative terms (e.g., a percentage of a standard -- air quality may be unacceptable if the level of one pollutant is 150% of its standard, even if levels of other pollutants are well below their respective standards).

greenhouse gas: Any of several gases that can absorb and emit infrared radiation in the atmosphere. Greenhouse gases include, but are not limited to, water vapor, carbon dioxide

(CO₂), methane (CH₄), nitrous oxide (N₂O), chlorofluorocarbons (CFCs), hydrochlorofluorocarbons (HCFCs), ozone (O₃), hydrofluorocarbons (HFCs), perfluorocarbons (PFCs), and sulfur hexafluoride (SF₆). Greenhouse gases contribute to the amount of heat energy trapped at the Earth's surface and in the lower atmosphere.

National Ambient Air Quality Standards (NAAQS): The concentrations of criteria pollutants and the lengths of exposure in the open air established by federal regulation above which adverse health and welfare effects may occur.

cumulative impact: The impact on the environment which results from the incremental impact of the action when added to other past, present, and reasonably foreseeable future actions regardless of what agency or person undertakes such other actions. Cumulative impacts can result from individually minor but collectively significant actions taking place over a period of time.

climate change: Climate change refers to any significant change in measures of climate (such as temperature, precipitation, or wind) lasting for an extended period (decades or longer). Climate change may result from natural factors and processes within the climate system or human activities that change the atmosphere's characteristics and the land surface.

global warming: An average increase in the temperature of the atmosphere near the Earth's surface and in the troposphere, which can contribute to changes in global climate patterns. Global warming can occur from a variety of causes, both natural and human induced. In common usage, "global warming" often refers to the warming that is believed to occur as a result of increased emissions of greenhouse gases from human activities.

■ Geology and Soils

enhanced oil recovery (EOR): Oil recovery by any means other than by natural fluid pressure or normal well pumping. Its purpose is to improve oil displacement or fluid flow in the reservoir toward producing wells or to add energy to the reservoir to aid production of oil. The dominant secondary process of oil recovery is "water flooding." The three major types of tertiary oil recovery are chemical flooding, miscible displacement (CO₂ injection or hydrocarbon injection), and thermal recovery.

prime farmland: Land that has the best combination of physical and chemical characteristics for producing food, feed, fiber, forage, oilseed, and other agricultural crops with minimum inputs of fuel, fertilizer, pesticides, and labor, and without intolerable soil erosion.

■ Water Resources

aquifer: Underground geologic formation composed of permeable layers of rock or sediment that holds or transmits water.

confining unit: A body of impermeable or distinctly less permeable material stratigraphically adjacent to one or more aquifers.

floodplain: Any land area susceptible to being inundated by flood waters from any source.

groundwater: Water below the ground surface in a zone of saturation within a geologic stratum that supplies wells and springs.

outfall: The discharge point of a waste stream into a body of water.

surface water: Water above the ground surface including wetlands, floodplains, lakes, bayous, and streams, and the watersheds and estuaries of which they are a part.

total maximum daily load (TMDL): The total quantity (or load) of a pollutant that a stream can carry and still conform to designated uses and water quality criteria. TMDL also refers to a regulatory process that states, territories, and authorized tribes use to determine allowable pollutant concentrations in streams.

underground source of drinking water (USDW): as defined in Title 40, Code of Federal Regulations (40 CFR), Section 144.3, an aquifer or part of an aquifer which: supplies any public water system, or contains a sufficient quantity of ground water to supply a public water system and currently supplies drinking water for human consumption or contains fewer than 10,000 milligrams/liter of total dissolved solids (TDS), and is not an exempted aquifer.

wetlands: Those areas that are inundated or saturated by surface or ground water at a frequency and duration sufficient to support, and that under normal circumstances do support, a prevalence of vegetation typically adapted for life in saturated soil conditions. Indicators of wetland include types of plants, soil characteristics, and hydrology of the area. Wetlands generally include swamps, marshes, bogs and similar areas.

■ Biological Resources

biological resources: The vegetation and wildlife that are part of ecosystems, including native, common, endangered, threatened and invasive species.

endangered species: Animals, birds, fish, plants, or other living organisms threatened with extinction by anthropogenic (man-caused) or natural changes in their environment throughout all or a significant portion of its range or territory.

threatened species: A species that is likely to become an endangered species within the foreseeable future throughout all or a significant part of its range.

■ Cultural Resources

Area of Potential Effect (APE): The geographic region that may be impacted as a result of the construction and operation of the proposed project or alternatives.

archaeological resources: Material remains of past activity.

cultural resources: Archaeological sites, historical sites (e.g., structures made during the period of written history), Native-American resources, and paleontological resources.

historical site: A site that is more than 50 years old.

■ Land Use

land use plan: A set of decisions that establish management direction for land within an administrative area, as prescribed under the planning provisions of FLPMA; an assimilation of land-use and plan-level decisions developed through the planning process outlined in 43 CFR 1600, regardless of the scale at which the decisions were developed.

■ Socioeconomics

stakeholder: A person, group, or organization that has direct or indirect interest in an organization because it can affect or be affected by the organization's actions, objectives, and policies

environmental justice: The fair treatment and meaningful involvement of all people regardless of race, color, national origin, or income with respect to the development, implementation, and enforcement of environmental laws, regulations, and policies. Fair treatment means that no group of people, including racial, ethnic, or socioeconomic groups, should bear a disproportionate share of the negative environmental consequences resulting from industrial, municipal, and commercial operations or the execution of Federal, state, local, and tribal programs and policies. Executive Order 12898 directs Federal agencies to make achieving environmental justice part of their missions by identifying and addressing disproportionately high and adverse effects of agency programs, policies, and activities on minority and low-income populations.

environmental justice area: The community of comparison (COC) approach that the federal government uses to define an environmental justice area analyzes the economic and racial factors of a potentially impacted community and compares the same factors to that of the county, state, or Nation.

census tract: A small, relatively permanent statistical subdivision of a county. Census tracts, which average about 4,000 inhabitants, are designed to be relatively homogeneous units with respect to population characteristics, economic status, and living conditions.

■ Transportation and Traffic

level of service (LOS): A scale that measures the quality of service of a roadway. Six levels of service are assigned letter designations ranging from A to F, with LOS A (free flow, little delay) representing the best operating conditions from the travelers' perspective and LOS F (congestion, long delays) representing the worst conditions.

■ Noise

ambient noise: Background noise associated with a given environment. Ambient noise is typically formed as a composite of sounds from many near and far sources, with no particular dominant sound.

dBA (A-weighted decibels): The unit of noise measurement is a decibel (dB). The most common weighting scale used is the A-weighted scale, which was developed to allow sound-level meters to simulate the frequency sensitivity of human hearing. Sound levels measured using this weighting are noted as dBA (A-weighted decibels; “A” indicates that the sound has been filtered to reduce the strength of very low and very high frequency sounds, much as the human ear does). The A-weighted scale is logarithmic, so an increase of 10 dB actually represents a sound that is 10 times louder. However, humans perceive the 10 dBA increase as twice as loud, not 10 times louder.

noise receptors: Locations where noise is modeled and/or measured. Noise receptors are defined as places where people are typically located, such as residences, hotels, commercial buildings, parks, etc. Usually, one noise receptor location is used to analyze an area unless the area is large and covers varying terrain and distances from the noise source under consideration. Primary consideration for the location of noise receptors is outdoor areas of frequent human use. For residential and other structures, this typically would be the outdoor area of frequent human use closest to the proposed project.

■ Wastes

construction wastes: Discarded materials generally considered to be not water soluble and non-hazardous in nature, including but not limited to steel, glass, brick, concrete, asphalt material, pipe, gypsum wallboard, and lumber, from the construction of a structure as part of a project. The term includes rocks, soils, tree remains and other vegetative matter which normally results from land clearing for a construction project; cardboard, paper, plastic, wood, and metal scraps from a construction project; unpainted, non-treated wood scraps and unpainted, non-treated wood pallets.

slag: A mixture of a glassy, silica-based material known as “frit” and carbon char, the proportions of which vary depending on operating conditions, gasifier, feed characteristics, etc. The two parts can be separated and concentrated into carbon-rich char and vitreous frit.

■ Materials

bentonite: a natural volcanic clay commonly added to water to make a thick drilling fluid, which transports drill cuttings along the bore hole better than water alone and which reduces losses of drilling fluids into the soil and rock surrounding the borehole. It is composed primarily of montmorillonite (a phyllosilicate containing sodium and calcium as the principal cations, in a layered structure of aluminum-hydroxyl silicate) with small amounts of amorphous silica.

best management practices (BMPs): Methods for preventing or reducing pollution impacts resulting from an activity. BMPs include non-regulatory methods designed to minimize harm to the environment.

petroleum coke (petcoke): A high-carbon, high-sulfur, solid residue from a petroleum refining (cracking) process. The quality of the coke is dependent upon the crude oil processed in the refinery. Petcoke can be used as fuel for electricity production and for anode production.

■ **Human Health and Safety**

chemicals of concern: materials used or generated during operation with recognized hazardous characteristics such as toxicity and flammability and have a potential to impact human health or the environment.

OSHA recordable incident: A work-related accident that results in lost time, work restriction, medical treatment or death and reported according the Occupational Safety and Health Administration requirements.

supercritical carbon dioxide (CO₂): CO₂ is a colorless, odorless gas that occurs naturally in Earth's atmosphere. In its supercritical phase (when both the temperature and pressure equal or exceed the critical point of 31°C and 73 atmospheres), CO₂ can expand to fill a container (like a gas) but has a density more like a liquid. At very high concentrations, CO₂ is an asphyxiant.

This page left blank intentionally.

Summary

The U.S. Department of Energy (DOE) prepared this Environmental Impact Statement (EIS) to analyze the potential environmental impacts of providing cost-shared funding to Leucadia Energy, LLC (Leucadia) to implement their proposed project and to inform the decision of whether to provide such funding. Projects funded under the Industrial Carbon Capture and Sequestration (ICCS) program are cost-shared collaborations between the government and industry to increase investment in clean industrial technologies, carbon capture and sequestration (CCS), and beneficial use projects. In Section 703 of the Energy Independence and Security Act of 2007 (Pub. L. 110–140), Congress directed DOE to “carry out a program to demonstrate technologies for the large-scale capture of carbon dioxide (CO₂) from industrial sources.”

DOE sought projects with technologies that have progressed beyond the research and development stage to a point of readiness for operation at a scale that, if successful, could be readily replicated and commercially deployed. DOE selected Leucadia Energy’s Lake Charles Carbon Capture and Sequestration project (Lake Charles CCS project) as one of three projects for funding. Leucadia’s Lake Charles CCS project involves the capture and sequestration of CO₂ from the Lake Charles Clean Energy (LCCE Gasification plant), a petroleum coke gasification plant to be constructed by Lake Charles Clean Energy, LLC, in Calcasieu Parish, adjacent to the Port of Lake Charles, Louisiana. The proposed project that would receive DOE’s co-funding would be designed and implemented to demonstrate the capture, transport, and permanent storage of approximately 1 million tons per year of CO₂. Leucadia’s LCCE Gasification plant would not receive co-funding from DOE.

Congress, through the Energy Independence and Security Act of 2007, directed DOE to expedite and carry out large-scale testing of CO₂ sequestration systems in a range of geologic formations, including the expansion of CO₂ EOR to new settings, while providing information on the cost and feasibility of deployment of sequestration technologies.

Two of the projects selected under the ICCS program--the proposed Lake Charles CCS project and the *Air Products and Chemicals, Inc. (Air Products) Demonstration of CO₂ Capture and Sequestration of Steam Methane Reforming Process Gas Used for Large Scale Hydrogen Production Project* (DOE/EA-1846)-- would contribute CO₂ derived from industrial processes to the existing Green Pipeline owned by Denbury Onshore, LLC (Denbury). Denbury would then sequester the CO₂ in a portion of the Hastings oil field in Texas through ongoing enhanced oil recovery (EOR) operations.

S-1 DOE’s Proposed Action, Purpose, and Need

DOE’s proposed action is to provide financial assistance to Leucadia for the Lake Charles CCS project. DOE proposes to provide Leucadia with up to \$261.4 million of cost-shared financial assistance. The financial assistance would apply to the planning, designing, permitting, equipment procurement, construction, startup, and demonstration of the CCS technology and a research monitoring, verification, and accounting (MVA) program that would be established to

provide high level of confidence that the CO₂ injected in a portion of West Hastings field during existing EOR operations will remain permanently sequestered. DOE's contribution of \$261.4 million would constitute about 60 percent of the total development and capital cost of the Lake Charles CCS project, which is estimated to be \$435.6 million (2010 dollars). The Lake Charles CCS project and the Air Products CCS project would jointly fund the research MVA program performed at the West Hastings Oil Field. The project would further the objective of the ICCS program by demonstrating an advanced technology that integrates CO₂ capture into an industrial source and by monitoring the sequestration of CO₂ in an underground formation.

The purpose for DOE's proposed action is to advance the ICCS program by providing financial assistance to projects that have the best chance of achieving the program's objectives as established by Congress. The principal need addressed by DOE's proposed action is to satisfy the responsibility Congress imposed on DOE to demonstrate the next generation of technologies that will capture CO₂ emissions from industrial sources and either sequester or beneficially use the CO₂.

Scope of the Environmental Analysis

This EIS identifies and analyzes the potential impacts of the proposed action: the co-funding of Leucadia's Lake Charles CCS project. Though DOE funds would only apply to the CCS project, DOE determined that the LCCE Gasification plant is a connected action in accordance with 40 CFR 1508.25 (a), and its impacts are analyzed in the EIS. This EIS also assesses the potential environmental impacts of project-related options and the DOE's no action alternative.

This EIS evaluates the environmental and social impacts of DOE providing financial assistance for the Lake Charles CCS project.

This EIS reflects the most current design information available. Because the Air Products CCS project is proceeding and the West Hastings research MVA program would be jointly funded by Air Products, some activities and impacts from the West Hastings MVA program have already occurred. In addition, some activities and impacts from the site preparation for the LCCE Gasification plant have already occurred. Site preparation performed under USACE permits No. DACW29-9-08 (May 30, 2008) and MVN-1998-03311-WY (August 18, 2008) issued to the Port of Lake Charles commenced prior to DOE's selection of Leucadia's project. These activities are evaluated as part of this EIS. The scope of this EIS does not include current commercial operations, specifically the Green Pipeline and existing EOR operations at the West Hastings oil field. Denbury began CO₂ injections in Block A of the West Hastings oil field on December 16, 2010 (APCI 2011). The injection rates and production volumes would not change as a result of the proposed project and the DOE's decision on the proposed action. DOE determined the scope of this EIS based on internal planning and analysis, consultation with federal and state agencies, and the public scoping process. DOE published a Notice Of Intent (NOI) to prepare an EIS for this proposed action in the Federal Register on April 29, 2011 (Federal Register Doc. 2011-10448). Following publication of the NOI, DOE notified the public and stakeholders of the Lake Charles CCS project in several ways: in newspaper notices published in the affected communities, 100 postcards to local, state, and federal elected officials and agencies with jurisdictional interest in the project; and posting on Regulations.gov, a federal government website. Two public scoping meetings were held on May 16 and 17, 2011. The first scoping meeting was held in Pearland, Texas, and the second meeting was held in Westlake, Louisiana.

During the scoping period, comments were received from private citizens, businesses, and nongovernmental organizations. A total of 229 comments were received; 109 comments were generated at the scoping meetings and 120 comments were received in the mail. The written and oral comments were reviewed and considered during the preparation of this DEIS. The environmental resource areas and issues identified prior to and during scoping that received the majority of comments included: the purpose of and need for the project, the project description, air quality, CO₂ capture and sequestration, socioeconomics, contamination of land and water resources, wetland and waterbody impacts, safety, alternatives, and cumulative impacts.

Alternatives Considered

DOE will evaluate the project as proposed by Leucadia, any design alternatives still under consideration by Leucadia, and DOE's no action alternatives. This EIS briefly describes alternatives previously considered by Leucadia in developing the proposed project; however, DOE did not analyze these alternatives because they are no longer under consideration by Leucadia and because they were not part of the proposal that Leucadia offered and DOE accepted.

Under the no action alternative, DOE would not provide funding to Leucadia. In the absence of financial assistance from DOE, Leucadia could reasonably pursue several options. Leucadia could build both the LCCE Gasification plant and the Lake Charles CCS project with funding from other sources. DOE assumes that if Leucadia builds the LCCE Gasification plant and Lake Charles CCS project in the absence of DOE cost-shared funding, the plant would include the same features, attributes, and impacts described for the proposed project and connected action. Alternatively, Leucadia could choose not to build all or parts of the LCCE Gasification plant and Lake Charles CCS project. For the purpose of making a meaningful comparison between the impacts of DOE providing and withholding financial assistance, DOE assumed that all or part of the LCCE Gasification plant and Lake Charles CCS project would not be completed without DOE funds. Therefore, the following sub-alternatives were identified and analyzed in the EIS:

1. Neither the LCCE Gasification plant nor the Lake Charles CCS project would be built, or
2. The LCCE Gasification plant would be built, but the captured CO₂ would be vented to the atmosphere and not sequestered in an ongoing EOR operation.

The ongoing commercial CO₂ EOR operations and the West Hastings research MVA program would continue under each of these no action options. In the absence of Leucadia's participation, Air Products would fund the entire non-DOE share of the research MVA program under a separate project agreement.

S-2 Leucadia's Proposed Project

Leucadia's proposed project would: (1) demonstrate advanced technologies that integrate the capture of CO₂ into an industrial source and (2) provide an accurate accounting of CO₂ stored and a high level of confidence that the CO₂ injected in a portion of West Hastings field during existing EOR operations will remain permanently sequestered. The Lake Charles CCS project would demonstrate the capture and sequestration of CO₂ from Leucadia's Lake Charles Clean Energy Gasification plant (LCCE Gasification plant). Figure S-1 illustrates the general locations

of the proposed Lake Charles CCS project, the LCCE Gasification plant (connected action), and the existing commercial EOR operations. The primary components of Leucadia's proposed project are:

1. LCCE Gasification Plant (the Connected Action)

The LCCE Gasification plant would use four General Electric quench gasifiers to convert petroleum coke into syngas. The syngas would be further processed to produce methanol, hydrogen gas, and sulfuric acid, as well as CO₂. The LCCE Gasification plant would provide raw syngas containing CO₂ to the Lake Charles CCS project, where the CO₂ would be separated from the syngas.

2. Lake Charles CCS CO₂ Capture and Compression

The CO₂ capture equipment would consist of two Lurgi Rectisol Acid Gas Removal (AGR) units in which CO₂ is separated from the process gas. The compression equipment would include two compressors that would pressurize the CO₂ to 2,250 pounds per square inch gauge (psig) for transport and geologic sequestration. Approximately 4.6 million tons per year of CO₂ would be captured from the LCCE Gasification plant.

3. Lake Charles CCS CO₂ Pipeline

Denbury, through an affiliate, would construct, own, and operate the proposed 11.9-mile-long CO₂ pipeline connecting to the existing Green Pipeline, which would transport the captured CO₂ to oil fields along the Gulf Coast, including the West Hastings oil field in Brazoria County, Texas. The proposed Lake Charles CCS CO₂ pipeline would begin at the proposed CO₂ meter station located at the fence line of the LCCE Gasification plant and would tie into the existing Green Pipeline at a location west of Buhler, Louisiana.

4. West Hastings Research MVA Program

Denbury and the Texas Bureau of Economic Geology (BEG) would jointly implement the West Hastings research MVA program aimed at providing: an accurate accounting of approximately 1 million tons of stored CO₂, and a high level of confidence that the CO₂ injected in a portion of West Hastings field during existing EOR operations will remain permanently sequestered. The research MVA activities would supplement Denbury's ongoing commercial monitoring activities and regulatory requirements performed for commercial CO₂ EOR and would provide additional information regarding the movement and confinement of CO₂.

Description of Technology and Location

LCCE Gasification Project (Connected Action)

The LCCE Gasification plant would consist of four General Electric Quench Gasifiers to convert petroleum coke into syngas and two trains of syngas processing to produce methanol, hydrogen gas, and sulfuric acid, as well as purified CO₂. The facility would be located on an approximately 70-acre parcel of land leased from the Lake Charles Harbor and Terminal District (Port of Lake Charles), on the west bank of the Calcasieu River adjacent to Bulk Terminal No. 1, in southern Calcasieu Parish, Louisiana.

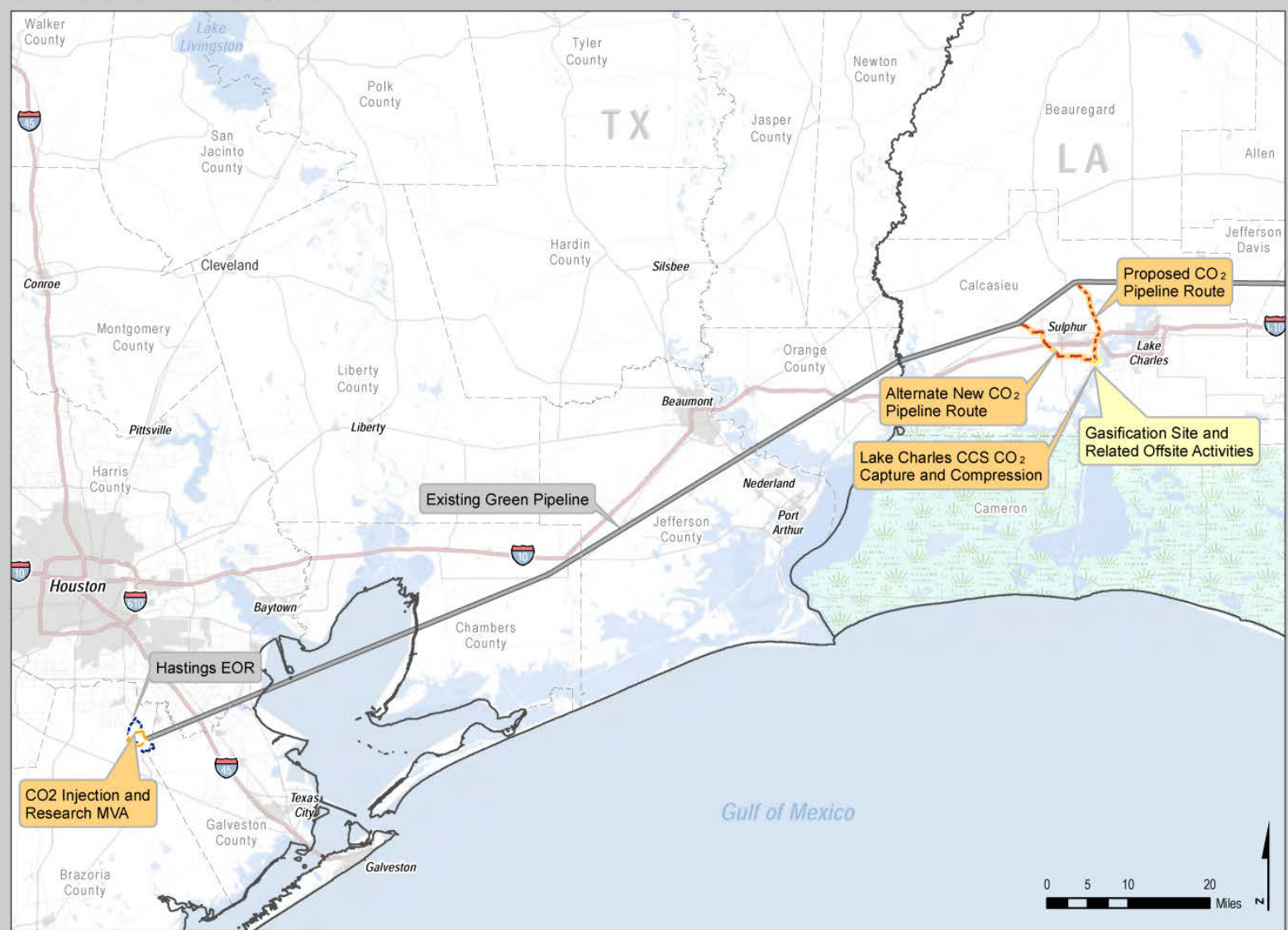

Figure S-1
Lake Charles CCS Project
Overall Location
 Texas and Louisiana

This page left blank intentionally.

Leucadia would purchase approximately 2.6 million tons of petcoke feedstock per year from marketing suppliers that supply, transport, and handle bulk petcoke. All of the petcoke feedstock purchased by Leucadia would originate from the Gulf Coast region, which produces approximately 58% of the U.S. petcoke supply. The Port of Lake Charles would transfer the petcoke from the Dry Bulk Terminal to the LCCE Gasification plant site via an elevated covered conveyor system. In the gasifier, the petcoke slurry and oxygen react, producing synthetic gas or “syngas” and heat. After cleaning in a scrubber column using water, the syngas consists primarily of H₂, CO, water, and CO₂, with small amounts of N₂ and hydrogen sulfide (H₂S), and trace amounts of methane (CH₄), carbonyl sulfide (COS), and ammonia. For the proposed project, a portion of the syngas would be reacted with water vapor over a catalyst, converting or “shifting” the CO to CO₂. The syngas would enter two Lurgi Rectisol Acid Gas Removal units (AGRs) to remove acid gases (H₂S, COS, and CO₂) from the syngas. The AGRs are part of the Lake Charles CCS project. The purified syngas from the AGRs would be fed into a methanol synthesis process, where H₂ and CO would react over a copper-based catalyst bed to produce AA-grade methanol. A portion of the purified syngas from the AGRs (after H₂S and CO₂ removal) would be fed to a hydrogen pressure swing absorption (PSA) unit, where hydrogen would be separated out and purified. Excess heat from plant processes would be used to generate steam, which would drive steam turbines to produce electric power. The electricity would be used to provide a significant portion of the energy needs for operations.

Petroleum coke, or “petcoke,” is a high-carbon, high-sulfur, solid residue from petroleum refining (cracking) process. Petcoke can be used as fuel for electricity production and for anode production. The majority of petcoke produced in the US is exported.

LCCE Gasification would require new utility linears and pipelines for delivery of materials and transport of products, including:

- 0.5 mile potable water line connecting to the City of Sulphur municipal water supply,
- 0.5 mile, 8-inch diameter natural gas pipeline connecting to Centerpoint Energy’s existing pipeline at Bayou D’Inde Road,
- 4 mile, 8-inch pipeline for water supply from the Sabine River Authority (SRA) via the Sabine River Diversion Canal,
- approximately 1 mile, 8-inch methanol pipeline to the off-site methanol and sulfuric acid storage area and a 12-inch diameter pipeline from the offsite storage area to the Port of Lake Charles,
- 8.5 mile hydrogen pipeline from LCCE Gasification to an existing hydrogen pipeline, and
- 0.5 mile electrical transmission line to obtain electricity for operation

Onsite storage would include six 550,000-gallon sulfuric acid tanks and six 1.6 million gallon methanol storage tanks. The offsite storage area would contain two 1.9 million gallon sulfuric acid storage tanks and four 7.5 million gallon methanol storage tanks. The storage area would likely be located within one mile of the LCCE Gasification plant site. Leucadia is in the process

of identifying and leasing a parcel of up to 40 acres required for the equipment laydown and storage area.

Lake Charles CCS CO₂ Capture and Compression

The Lake Charles CCS project would use two Lurgi Rectisol® AGRs to remove impurities from the syngas produced by the LCCE Gasification plant as shown in Figure S-2 (Leucadia 2012a). The AGRs would use chilled liquid methanol (-70 degrees F) as a gas-washing solvent to remove H₂S, COS, CO₂, and trace impurities that are by-products of syngas production. These 99% pure CO₂ streams would be routed to the CO₂ compressor. Leucadia would install two CO₂ gas compressors in parallel, one for each AGR unit. The compressors would compress the CO₂ gas streams from the AGRs to a pressure of approximately 2,250 psig for transport in a supercritical state, meaning the gas has flow properties like a liquid.

The supercritical liquid phase of CO₂ occurs at pressures greater than 72.9 atmospheres (1071.3psi) and temperatures of greater than 88 F (31.1 °C)

Lake Charles CCS CO₂ Pipeline

The proposed 11.9-mile-long CO₂ pipeline would connect to the existing Green Pipeline, which is owned and operated by affiliates of Denbury, for CO₂ transport to the Hastings Oil Field in Brazoria County, Texas. The proposed CO₂ pipeline would begin at the proposed CO₂ pipeline meter station located at the fence line of the LCCE Gasification plant and would tie into the existing Green Pipeline west of Buhler, Louisiana.

The proposed CO₂ pipeline route would be co-located along or within existing utility rights-of-way (ROWs) to the extent practicable, avoiding construction in greenfield areas to reduce potential environmental and socioeconomic impacts that could result from establishing new ROWs; and would avoid population centers and sensitive environmental resources. Figure S-3 shows the proposed pipeline route (preferred route) and two alternative routes. The pipeline would be located entirely within Calcasieu Parish and would require a temporary 95 foot corridor during construction that would parallel existing ROWs for transmission lines, roads, pipelines, railroads, and other linear features to the extent practicable. Denbury would maintain a permanent 50 foot ROW for operation of the pipeline.

The CO₂ pipeline would be designed, tested, and operated in accordance with applicable federal regulations. These include the U.S. Department of Transportation (DOT) regulations and the U.S. Department of Labor OSHA requirements, which were enacted to ensure adequate protection of the public and to help prevent pipeline accidents and failures. Denbury proposes to install mainline valves on both sides of each major waterbody crossing, including the Bayou d'Inde, the Sabine River Canal, and the Houston River (CH2M Hill 2011). Mainline valves would allow Denbury to stop the release of CO₂ should a puncture or rupture occur along the pipeline route. These valves, along with pipeline pressure monitoring equipment, would be monitored at all times during pipeline operation.

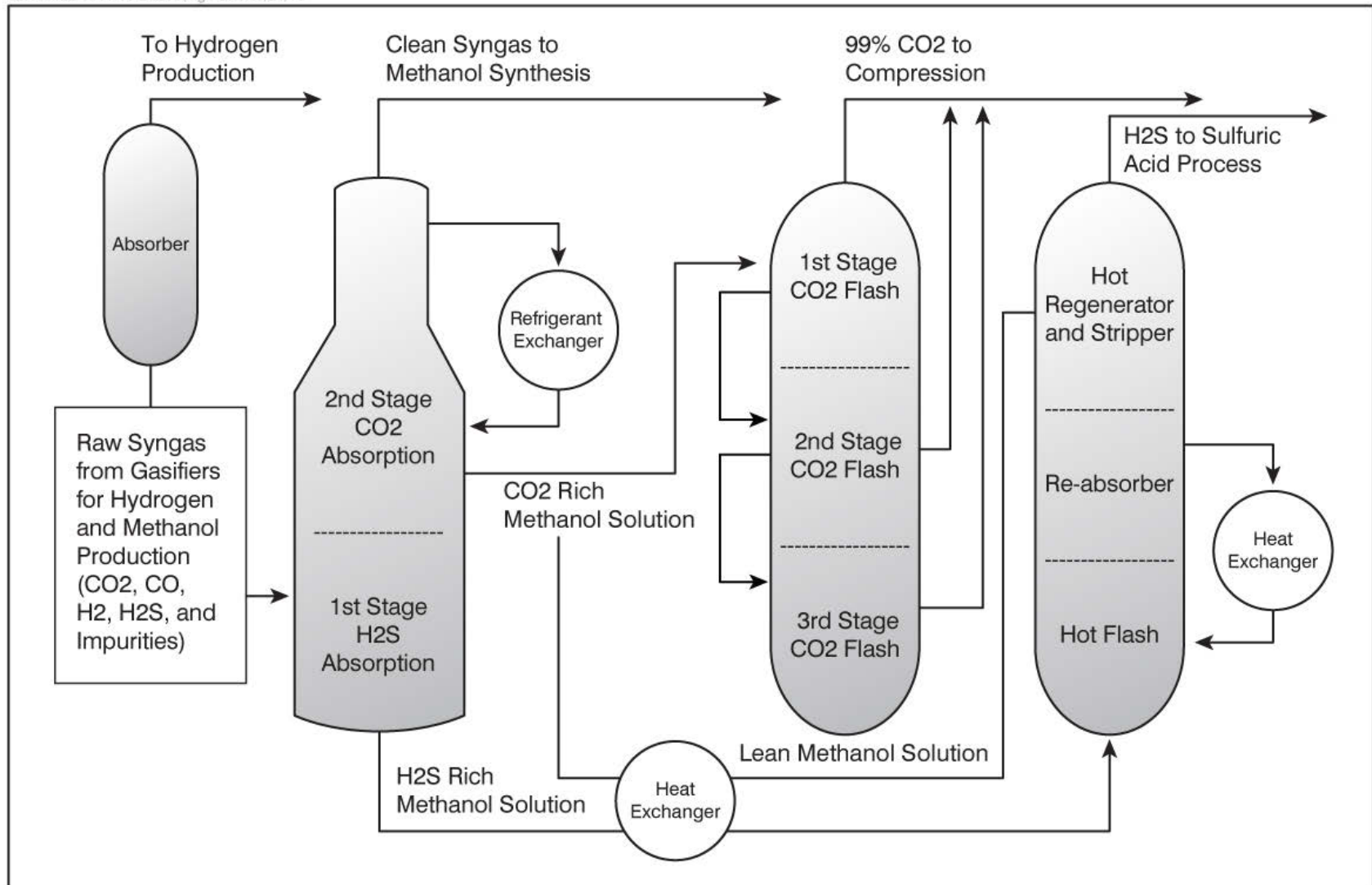
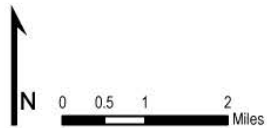
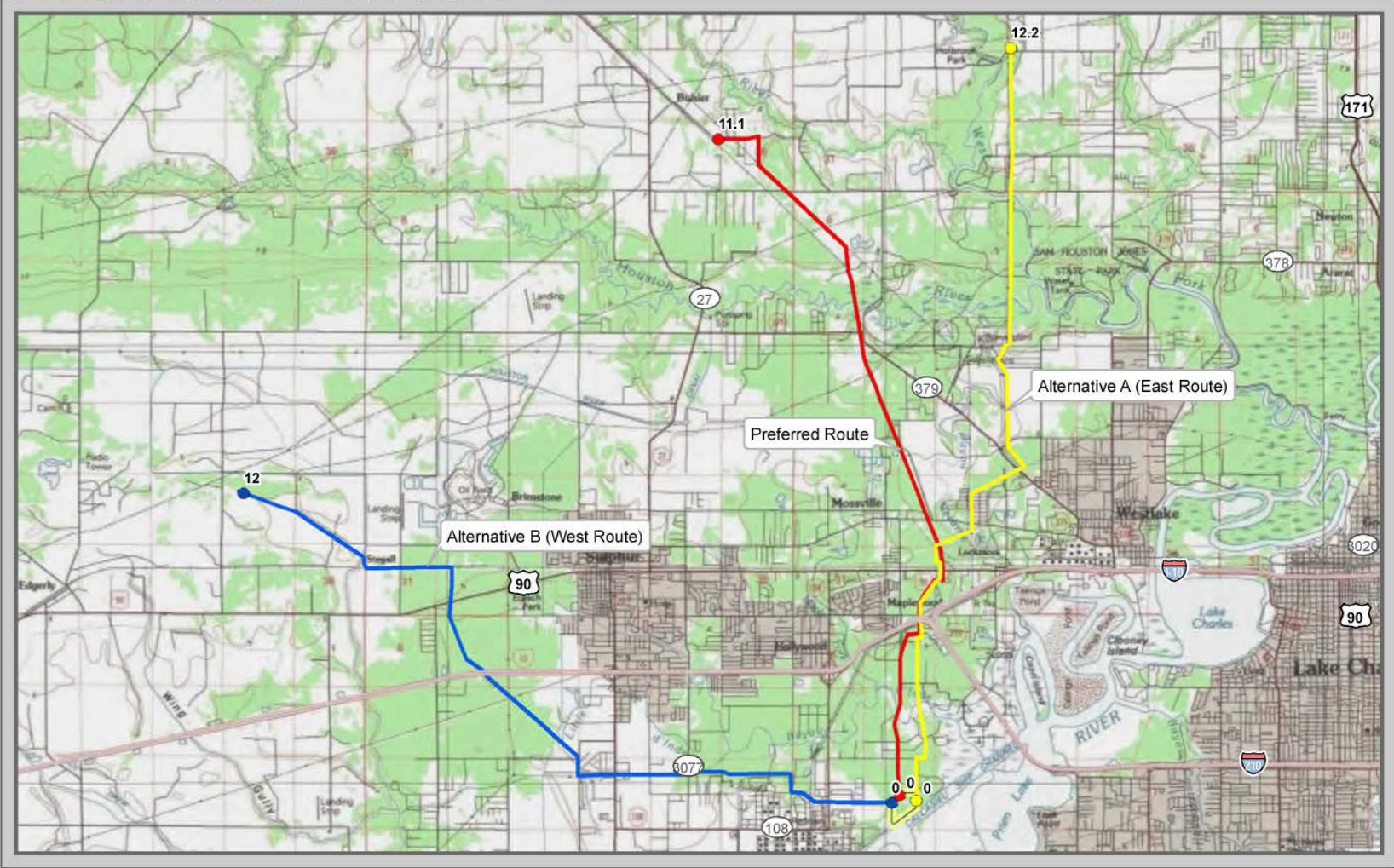

Figure S-2
Lurgi Rectisol[®] Acid Gas Removal System

This page left blank intentionally.



- Preferred Route Milepost
- Alternative A (East Route) Milepost
- Alternative B (West Route) Milepost
- Preferred Route
- Alternative A (East Route)
- Alternative B (West Route)
- LCCE Gasification Site and Related Offsite Activities

Figure S-3
Alternative and Preferred Pipeline Routes
Calcasieu Parish, Louisiana

This page left blank intentionally.

West Hastings Research MVA

The Hastings oil field is located between Alvin and Pearland, Texas, near State Highway 35, south of Houston. The Hastings oil field underlies approximately 25 square miles of rural farmlands, suburban areas, and residential neighborhoods. The research MVA program would be limited to a parcel of approximately 2.8 square miles within the West Hastings oil field. Denbury and the BEG would implement the research MVA program to supplement regulatory requirements and commercial monitoring activities performed for Denbury's ongoing commercial EOR activities.

Denbury owns an interest in the West Hastings oil field and is currently conducting commercial EOR activities. Denbury commenced CO₂ injections in Block A of West Hastings oil field on December 16, 2010 (APCI 2011). This CO₂ injection process, referred to as a tertiary flood or EOR, requires large volumes of nearly pure CO₂. Denbury estimates that EOR over the entire West Hastings field will yield between 60 and 90 million barrels of oil that was not previously considered recoverable (APCI 2011).

The U.S. oil and gas industry has more than 35 years of continuous experience in transporting and injecting CO₂ for enhanced oil recovery (EOR).

Construction Plans

LCCE Gasification Plant and Lake Charles CCS Project CO₂ Capture and Compression

Construction of the LCCE Gasification plant and the Lake Charles CCS project CO₂ Capture and Compression equipment would occur together. Construction would begin with foundation and civil engineering work, the fabrication and installation of underground piping and electrical conduits, and the fabrication and erection of structural steel and buildings. Activities at the peak of construction would include equipment installation, fabrication, installation of aboveground piping, hydro-testing, electrical installation, instrumentation loop checks, and pre-commissioning. The last phase of construction would include the completion of electrical installation, instrumentation checks, and pre-commissioning activities.

Site preparation activities for the LCCE Gasification plant including clearing and grading commenced in January 2010. In addition, site preparation work to raise the site elevations to above the local 100-year and 500-year base flood elevations commenced in November 2010. These activities were authorized by the US Army Corps of Engineers permits (Lake Charles Harbor & Terminal District Consent No. DACW29-9-08 [May 30, 2008] and MVN-1998-03311-WY [August 18, 2008]). Construction of the LCCE Gasification plant would begin in the first quarter of 2014 and take approximately 36 months to complete. Peak construction is expected to occur in month 18 and involve approximately 2,500 workers, of which 900 would be on the LCCE Gasification plant site.

The majority of the construction materials would consist of concrete, wood, fuel, and steel. Construction materials would be obtained from national, regional, and local sources. Leucadia would use up to six 40-passenger shuttle buses to transport the construction workers from the remote parking area(s) to the construction site, using multiple routes that would avoid railway crossings and high-volume commuter traffic routes. Vehicles that would be used on-site include dump trucks for hauling soil, stake trucks for hauling supplies, water trucks for watering roads, and passenger buses for transporting workers from parking areas to the construction zone. The

average number of dedicated on-site vehicles is estimated to be about 55 per day, with about 80 vehicles per day during peak activity (Leucadia 2011). Off-site construction vehicles would include concrete, asphalt, and equipment delivery trucks. During foundation work, 150 construction vehicles would enter and leave the site. Major components including the gasifier, AGR, and ASU would be transported from international locations via ocean-going vessels and delivered to the Port of Houston or the Port of New Orleans. Barges would transport equipment from the ports through the Intracoastal Waterway or the Gulf of Mexico into the Calcasieu River ship channel and be offloaded at the LCCE Gasification site. Conventional building supplies would be delivered by truck.

Construction would require water for dust control, concrete mixing, cleaning, sanitary use, and hydrostatic testing of pipelines. The City of Sulphur would upgrade an existing potable water pipeline to supply approximately 6,000 gallons per day to the LCCE Gasification plant. Approximately 682,000 gallons of water would be withdrawn from Bayou D'Inde, the Sabine Canal, and municipal sources for hydrostatic testing of the pipelines associated with LCCE Gasification (Leucadia 2012b). Leucadia would monitor and test discharges to properly characterize potential waste constituents prior to disposal under a Hydrostatic Test Discharge Permit.

Emissions produced during construction would consist of exhaust emissions from construction-related equipment and worker and delivery vehicles, and dust generated during soil-disturbing activities. Construction would generate typical construction wastes, such as equipment packaging, surplus materials, and empty containers, as well as small quantities of potentially hazardous waste. Solid wastes would be collected for disposal in a public landfill. Small quantities of potentially hazardous materials and wastes, such as fuels, oils, lubricants, and solvents, would be stored in appropriate containers in a secure location on site. Scrap and surplus materials and used lube oils would be recycled or reused to the maximum extent practicable. Leucadia, and its contractors, would be responsible for the proper handling and disposal of construction wastes. These requirements include waste minimization and the proper handling, storage, and disposal of hazardous and non-hazardous wastes.

Lake Charles CCS Project CO₂ Pipeline

Construction of the CO₂ pipeline would be completed by Denbury in the third quarter of 2014. Construction would include installation of the pipeline within the construction ROW, temporary use of pipe storage yards, and construction of the metering and valve facilities. Construction would progress along the linear route, and no location along the ROW would be impacted for more than 3 months. Standard pipeline construction would include surveying and staking of the ROW, clearing and grading, trenching, pipeline stringing and bending, welding and coating, lowering-in and backfilling, hydrostatic testing, and cleanup and restoration. Clearing and grading would generally be conducted in a single pass for a given pipeline spread (CH2M Hill 2010). Construction would require an average of approximately 100 workers, with the total number of construction workers reaching 250 at peak construction times.

Construction equipment would typically include excavators, as well as smaller equipment such as backhoes, dump trucks, compactors, compressors, and welding equipment. Work crews would operate at different points along the pipeline route and would park up to 50 vehicles at staging areas or at designated work locations along the pipeline route during the day. Approximately 20 pipeline inspectors would use up to 10 trucks daily to travel from one segment

of the pipeline to the next during construction. Access to the temporary and permanent pipeline ROWs and associated facilities would be through existing public and private roads to the extent practicable.

Water used for hydrostatic testing of the pipeline would be obtained from local waterbodies and municipal sources, and would be reused for subsequent pressure tests, if practicable. Denbury would use approximately 550,000 gallons of water for hydrostatic testing of the CO₂ pipeline. Denbury would monitor and test discharges to properly characterize potential contaminants prior to disposal under a Hydrostatic Test Discharge Permit.

Emissions produced during construction of the CO₂ pipeline would consist of exhaust emissions from construction-related equipment and dust generated during soil-disturbing activities. Wastes generated during construction of the proposed CO₂ pipeline would primarily consist of nonhazardous materials, including land clearing waste, packaging materials, general refuse, directional drilling fluids, and hydrostatic test water. Denbury would arrange for acceptable off-site disposal (e.g., at landfills, other construction areas needing fill material, etc.) of any debris that is not suitable for placement on the ROWs.

West Hastings Research MVA Program

Denbury currently performs CO₂ injection for EOR and ongoing commercial monitoring activities in the West Hastings oil field. As part of its commercial operations, Denbury constructed new facilities and drilled or reworked existing wells in the West Hastings oil field for CO₂ EOR, production of oil and gas, testing, water production, and brine disposal. As the West Hastings oil field is developed for commercial EOR, Denbury's ongoing EOR activities will include the reworking of existing and construction of new facilities as needed. Denbury's commercial EOR activities are an ongoing operation and are not evaluated in this DEIS.

Denbury would not drill any new wells or construct any new facilities for the West Hastings research MVA program. Denbury and BEG would conduct the West Hastings research MVA activities using existing wells for monitoring wells and access these wells from existing roads.

Operation

LCCE Gasification and Lake Charles CCS CO₂ Capture and Compression

Operation of the LCCE Gasification plant would include operation of the CO₂ Capture and Compression equipment. Since operations would continue after the expiration of the American Recovery and Reinvestment Act of 2009 (Recovery Act) funding, Leucadia would provide DOE with information necessary to determine whether the commercial-scale technology operations at the LCCE Gasification plant are making progress toward meeting the requirement of the funding opportunity announcement for the capture and sequestration of 75% of the CO₂ from the treated stream, comprising at least 10% of CO₂ by volume, which would otherwise be emitted to the atmosphere. The demand for CO₂ would be expected to continue for the life of the gasification plant, which is typically 30 years.

Operation would require 187 skilled operations and maintenance personnel. The workers would include a mix of plant operators, skilled craftsmen, managers, supervisors, engineers, and clerical workers. Approximately 196 vehicles would access the site daily for the purpose of worker transportation, deliveries of material, export of products, and removal of waste. Methanol would

be shipped from the methanol storage tanks to buyers using multiple modes of transportation, including trucks, railcars, barges, and ships. On average, the shipping of methanol would involve 8 to 10 trucks and 6 to 8 railcars per day, 10 to 30 barges per month (depending on the size of the barges), and approximately 1.5 ships per month (Leucadia 2012c).

During operation, process materials and chemicals would be used and stored at the site. Table S-1 summarizes the major resources required for operation of the LCCE Gasification plant.

Table S-1 Resource Consumption for Operation of LCCE Gasification and Lake Charles CCS CO₂ Capture and Compression

Resource	Quantity ¹
Petroleum coke	6,679 tons per day
Fluxant	200 tons per day
Aqueous ammonia	5,500 gallons per day
Natural gas	4.16 mmscf
Water	8,500 GPM
Power (from Entergy)	80 MW
Fuel (vehicles and equipment)	175 gallons per day

¹ Estimate based on full-load operation.

Key:

- GPM = gallons per minute
- MW = megawatts (continuous)

The primary materials used by LLCE Gasification are petcoke, fluxant, aqueous ammonia, water, and natural gas. Leucadia estimates that approximately 20% (0.5 million tons per year) of the petroleum coke (petcoke) will be locally produced petcoke already arriving at the Port of Lake Charles. The remaining 80% of the petcoke needed (approximately 2.1 million tons per year) would primarily come from other ports in the U.S. Gulf of Mexico (USGM) region. Leucadia identified sources of petroleum coke shipping from five USGM ports: Pascagoula, Mississippi; New Orleans, Louisiana; and Port Arthur, Houston, and Corpus Christi, Texas. Fluxant would be used to control and maintain the proper slag fluid temperature and viscosity on the walls of the gasifiers. The principal components of the fluxant are calcium and silica. Aqueous ammonia would be used to control emissions of nitrogen oxides in selective catalytic reduction equipment and the boilers used for onsite power generation. Natural gas would be used in various processes to preheat gasifier units, as a pilot fuel for the flare, as a supplementary fuel to the auxiliary boiler, and as a supplementary fuel for combusting vented gases. Leucadia would use process water for cooling tower makeup, operation (service water), and fire protection. The water supply from the Sabine River Authority would be treated to the required quality using a clarifier; additional treatment would depend on the use of the water. The LCCE Gasification plant would supply water to the Lake Charles CCS CO₂ Capture and Compression facility's cooling system as part of the ancillary services. Potable water would be supplied from the City of Sulphur. The LCCE Gasification plant would provide approximately 86 MW to the CO₂ Capture and Compression facilities based on an availability of 92.5% (Leucadia 2012c). The Lake Charles CCS project CO₂ Capture and Compression process uses methanol as a solvent to separate acid gases such as hydrogen sulfide and carbon dioxide from valuable feed gas streams. The methanol produced by LCCE Gasification would replenish any consumption of methanol in the capture system. In addition to regulatory requirements, Leucadia would follow the chemical suppliers' recommendations and procedures in storing and handling all materials and chemicals.

Table S-2 summarizes the major outputs, discharges, and waste from operation of the LCCE Gasification plant and Lake Charles CO₂ Capture and Compression equipment. The Lake Charles CCS project would be designed to achieve approximately 89 percent by weight CO₂ capture efficiency during steady-state operations.

Table S-2 Major Outputs, Discharges, and Wastes from Operation of the LCCE Gasification Plant and Lake Charles CO₂ Capture and Compression (annual unless otherwise stated)

Material	Quantity ¹
Outputs	
Methanol	4200 tons per day
Hydrogen, 99%	119 MSCF per day
Sulfuric acid	421,000 tons
Carbon dioxide (CO ₂)	5.2 M tons
Wastewater	
General industrial wastewater	412 gpm
Sanitary wastewater	13 gpm
Cooling tower blowdown	761 gpm
Air Emissions (tons)²	
Carbon dioxide CO ₂	642,400 ³
Particulate matter (PM ₁₀)	76
Sulfur dioxide (SO ₂)	132
Nitrogen oxide (NO ₂)	166
Carbon monoxide (CO)	524
Volatile organic compounds (VOCs)	14
Hydrogen sulfide	1
Sulfuric Acid	57
Methanol	9
Carbonyl sulfide	1
Ammonia	35
Wastes	
Gasifier slag	63,000 tons
Air filters for ASU	< 4,000 ft ³
Spent ASU molecular sieve and activated alumina	<1000 ft ³
Spent catalyst	<10,000 ft ³
Water treatment clarifier sludge filter cake (from treating river water)	<2,000 tons
Zero liquid discharge system solids	365 tons

1 The annual production quantities are based on estimated capacity factor and availability. Wastewater quantities based on average ambient conditions per the water balance diagram.

2 Annual emissions are based on the June 2012 air permit, except for CO₂.

3 With CO₂ capture system operating.

Key:

ASU = Air separation unit

ft³ = cubic feet

M = Million

MSCF = million standard cubic feet

The Louisiana Department of Environmental Quality (LDEQ) pollutant discharge elimination system permits (LA0124541 and AI No. 160213) define the wastewater discharge limitations for the LCCE Gasification plant during operation for two outfalls on the Calcasieu River. Industrial wastewater discharges would consist of non-contact cooling water blowdown from the circulating water system, reverse osmosis and demineralizer reject, and oil/water separator water

(plant and equipment drains). Leucadia would implement zero liquid discharge (ZLD) for the gasification process wastewater, resulting in no discharge of gasification process wastewater. Leucadia would collect and reuse storm water from the gasification equipment area.

Air emission limits for the LCCE Gasification plant during operation are set forth in the June 29, 2012, LDEQ air permit (PSD-LA-742 and 0520-00411-V0). The permit reflects potential CO₂ emissions without the Lake Charles CCS project operating. If CO₂ is not captured and compressed, each AGR unit would direct the CO₂ stream to a regenerative thermal oxidizer, which would thermally destruct greater than 99% of the residual CO, H₂S, COS, and methanol contained in the CO₂ stream before discharging it to the atmosphere.

The primary solid waste stream would be slag, which is formed in the gasifier at temperatures above the melting point of the feed materials. Slag is an inert glass-like material and a potentially marketable solid by-product. The physical form of slag is the result of gasifier operation at temperatures above the fusion, or melting, temperature of the mineral matter (DOE 2002). Leucadia would dispose of slag as a nonhazardous by-product or sell it to various commercial markets. Solids from the ZLD process, estimated to be less than 1 ton per day, may be characterized as hazardous waste due to heavy metal concentrations. Any wastes generated from operations or maintenance would be properly managed and disposed of off-site at an appropriately permitted facility.

Lake Charles CCS Project CO₂ Pipeline

Electricity for pipeline operations would be obtained from the existing electric distribution system adjacent to the proposed pipeline to power equipment, including main line valves. The meter station would obtain power from Denbury's existing electrical distribution system. During operation, the only waste would be that generated by clearing activities required to maintain the ROW in a condition accessible for vehicles. Any wastes generated from operations or maintenance would be properly managed and disposed of off-site at an appropriately permitted facility.

Denbury would operate and maintain the CO₂ pipeline in accordance with the federal DOT Safety Standards in 49 CFR 195. The safety standards specified in 49 CFR 195 require the pipeline operator to develop and implement an emergency plan working in conjunction with local fire departments and other agencies. Maintenance of the pipeline would include periodic visual inspections and routine pedestrian surveys, as necessary, in accordance with applicable regulatory requirements and Denbury's Operation and Maintenance Manual. The valve sites, meter station, and associated equipment could potentially emit fugitive gas with the same chemical composition as the CO₂ stream in the pipeline. Leak inspections and cathodic protection maintenance would be conducted in accordance with DOT requirements and Denbury's internal requirements. Pipeline markers and signs would be inspected and maintained or replaced, as necessary, to ensure that the pipeline location at critical points is clearly identified. Maintenance of the pipeline would include periodic vegetation mowing to allow for visual pipeline inspections.

West Hastings Research MVA Program

The primary components of the research MVA program would be reworking or recompleting of wells, installation of monitoring equipment, data collection and performance testing, computer modeling, and analysis of data. Most of the activities related to the West Hastings research

MVA program would be conducted at the existing West Hastings oil field in conjunction with ongoing, commercial EOR activities. Some analytical work, modeling, and other evaluation of the data would be performed at off-site locations, such as the BEG (Steve Walden Consulting and RDB Environmental Consulting 2010a). The research MVA program would use power to operate monitoring and computer equipment.

In 2012, Denbury converted one existing well in the Frio formation to a monitoring well and converted three existing wells to above zone monitoring wells in the Miocene formation. In 2013, Denbury would convert one existing well in the Frio formation to a monitoring well and two existing wells to above zone monitoring wells in the Miocene formation. The Frio monitoring wells would have permanently installed instrumentation that allows for continuous monitoring of reservoir (Frio) pressure and temperature, surface tubing pressure, and casing pressures. The Miocene monitoring wells would also have permanently installed instrumentation that allows for continuous monitoring of the above-zone conditions. All monitoring wells would be logged periodically with conventional downhole logs to check for the presence of CO₂. Additional data would be collected via seismic imaging, gravity surveys, and soil gas and groundwater monitoring efforts at selected existing well sites. CO₂ injection volumes would be continuously measured at each injection well and monitored remotely as part of the ongoing EOR operation.

After the West Hastings research MVA program is completed, commercial EOR activities would continue. Denbury's normal commercial EOR activities include recompletions and reconditioning of existing wells, well integrity testing, modeling and monitoring of the CO₂ during injection of CO₂ and production of oil, and monitoring of pressures within the field for purposes of management of the EOR process.

Emissions associated with the West Hastings research MVA activities would occur during reconditioning existing wells within the West Hastings oil field into monitoring wells. The emissions would include material handling (e.g., dirt moving) and emissions from internal combustion engines (gasoline and diesel) in mobile sources (off-road and on-road vehicles). Minimal quantities of drilling mud and associated wastes generated during reworking or recompleting operations would be landfarmed on-site in accordance with RRC regulations or disposed of in commercial disposal facilities.

Alternatives

Alternatives Considered during the Selection Process

DOE's alternatives to the Lake Charles CCS project consisted of the technically acceptable applications received in response to the *Funding Opportunity Announcement, Carbon Capture and Sequestration from Industrial Sources and Innovative Concepts for Beneficial CO₂ Use (DE-FOA-0000015)*. Prior to selection, DOE made preliminary determinations regarding the level of review required by NEPA based on potentially significant impacts identified in reviews of acceptable applications. Because DOE's proposed action is limited to providing financial assistance in cost-sharing arrangements to projects submitted by applicants in response to a competitive funding opportunity, DOE's decision is limited to either accepting or rejecting the project as proposed by the proponent, including its proposed technology and selected sites. DOE's consideration of reasonable alternatives is, therefore, limited to the technically acceptable applications and a no action alternative for each selected project.

No Action Alternative

Under the no action alternative, DOE would not provide funding to Leucadia. In the absence of financial assistance from DOE, Leucadia could reasonably pursue several options. Leucadia could build both the LCCE Gasification plant and the Lake Charles CCS project with funding from other sources. DOE assumes that if Leucadia builds the LCCE Gasification plant and Lake Charles CCS project in the absence of DOE cost-shared funding, the plant would include the same features, attributes, and impacts described for the proposed project and connected action. Alternatively, Leucadia could choose not to build all or parts of the LCCE Gasification plant and Lake Charles CCS project. For the purpose of making a meaningful comparison between the impacts of DOE providing and withholding financial assistance, DOE assumed that all or part of the LCCE Gasification plant and Lake Charles CCS project would not be completed without DOE funds. Therefore, DOE identified and analyzed the impacts of the following sub-alternatives:

1. Neither the LCCE Gasification plant nor the Lake Charles CCS project would be built, or
2. The LCCE Gasification plant would be built, but the captured CO₂ would be vented to the atmosphere and not sequestered in an ongoing EOR operation.

The ongoing commercial CO₂ EOR operations and the West Hastings research MVA program would continue under each of these no action options. In the absence of Leucadia's participation, Air Products would fund the entire non-DOE share of the research MVA program under a separate project agreement.

Project Alternatives Considered by the Applicant

Leucadia evaluated several technology components before selecting the most cost effective and appropriate designs, including conventional wastewater treatment technologies and the ZLD process for management of process wastewater; single-cylinder, between-bearing compressors and multi-cylinder, integrally geared compressors and Rectisol[®] and other sulfur-removal technologies, such as MDEA (methyl diethanolamine) and Selexol[™].

Denbury considered two alternative pipeline routes, Alternative A (East Route) and Alternative B (West Route), during the process of selecting the preferred pipeline route for the Lake Charles CCS project. Alternative pipeline routes A and B are shown on Figure S-3. Each of the routes originates at the LCCE Gasification plant and terminates at interconnect points on the existing Green Pipeline. Alternative A (East Route) was dismissed from further consideration. Alternative B (West Route) was carried forward for additional consideration.

S-3 Affected Environment

The affected environment is the geographic area that bounds the environmental, sociological, economic, or cultural resources potentially affected by the proposed project, the connected action, or the no action alternatives. In general, the affected environment for each of the 12 resource areas evaluated provides an overview of relevant information for both Louisiana and Texas before describing resource-specific information. Because the Air Products CCS project proceeded and the West Hastings MVA is jointly funded by Air Products and Leucadia, some

activities from the West Hastings MVA program have already occurred. Those activities which have already commenced are considered to be part of the existing environment for this analysis.

Climate and Air Quality

The LCCE Gasification plant and the Lake Charles CCS CO₂ Capture and Compression Facilities and CO₂ Pipeline are located within the same air quality control region in Calcasieu Parish. Calcasieu Parish is designated as attainment, or below standards for ambient air quality set for protection of public health. The parish was historically designated as in marginal nonattainment for the 1-hour ozone standard and requires a maintenance plan to ensure attainment. There are no Federal Class I areas within a 200-mile radius of the proposed project or connected action in Louisiana.

The West Hastings research MVA site is located in the Houston-Galveston Metropolitan Statistical Area (MSA) and Brazoria County. The entire MSA, including Brazoria County, is currently listed as a severe 8-hour ozone non-attainment area. With respect to Class I areas, the Caney Creek Wilderness Area (CACR1 Site) in Arkansas is located more than 611 kilometers (380 miles) from the West Hastings Research MVA site.

Geology and Soils

Generally, the surface of the West Gulf Coastal Plain in Louisiana consists of Quaternary (Pleistocene and Holocene) sediment deposited in or adjacent to rivers and deltas in a coastal-plain setting. Approximately 55% of the surface of the state consists of alluvium of the Mississippi and other rivers and tributaries, and coastal marsh deposits. The alluvium consists of sandy and gravelly channel deposits mantled by sandy to muddy natural levee deposits and organically rich muddy back swamp deposits. Coastal marsh deposits are chiefly mud and organic matter. The stratigraphic sequence in southwest Louisiana consists of unconsolidated deltaic and near-shore marine sediments. These sediments are characterized by clays and silty clays intersected by layers and lenses of silt and sand, and gravels. The project components are underlain by four silt loam soil series: Acadia silt loam, Basile and Guyton silt loams, Kinder-Messer silt loams, and Mowata-Vidrine silt loams.

The West Coastal Plain along the North Gulf Coast of Texas is characterized by nearly flat grasslands formed on Pleistocene- and Holocene-age deltaic sands, silts, and clays (Bureau of Economic Geology 1996). The stratigraphy and structure of the Hastings Oil Field is similar to that of the remainder of the southeastern Texas Coastal Plain in that it consists of a thick sequence of sedimentary strata that has been separated by faulting. The Frio Formation consists of interbedded sandy clays, sands, and sandstone (Chowdhury and Turco 2006), ranges in thickness from approximately 250 to 600 feet in the subsurface, and is approximately 6,600 feet below ground surface near the Hastings oil field. Underlying the Frio Formation is the Vicksburg Group, which is a regionally confining unit consisting primarily of marine clays and thinly bedded sandstones. The Anahuac Formation overlays the Frio Formation and serves as a stratigraphic seal and prevents the upward migration of hydrocarbons or other fluids. The project components are underlain by three soil types: the Bernard clay loam, Bernard-Edna complex, and Lake Charles clay.

The research MVA program will demonstrate the storage of CO₂ in the Frio Formation, which is approximately 6,600 feet below ground surface (bgs).

The area is generally seismically stable. The project area in Louisiana has a 2% probability of exceeding a peak horizontal acceleration (PHA) of 4% to 6% of gravity in 50 years, and that the project area in Texas has a 2% probability of exceeding a peak horizontal acceleration of 2% to 4% of gravity in 50 years.

Surface Water

The proposed project and connected action are located in the Calcasieu Estuary, which is divided into four major areas: Bayou Verdine, Bayou d'Inde, the Upper Calcasieu River, and the Lower Calcasieu River. Key waterbodies include the Calcasieu River, Prien Lake, the Calcasieu Ship Channel, the Houston River, Bayou Verdine, and Bayou d'Inde. The surface water resources along the proposed pipeline corridors include Bayou d'Inde, the Houston River, the SRD System Canal, and four perennial waterbodies and their associated marshes. Several segments of the Calcasieu River were placed on the Louisiana 2004 Section 303(d) list of impaired waterbodies that are monitored for elevated levels of mercury, copper, polychlorinated biphenyls (PCBs), and polycyclic aromatic hydrocarbons (PAHs) (USACE 2009). These impairments, along with elevated levels of fecal coliform bacteria and low dissolved oxygen, typically affect water use designations. In the area of the CO₂ pipeline, the West Fork Calcasieu River and the Houston River are classified as dystrophic waters, with seasonal dissolved oxygen criteria of 5 mg/L in winter and 3 mg/L in summer.

Floodplains

The Advisory Base Flood Elevation (ABFE) for the LCCE Gasification plant and the Lake Charles CCS project CO₂ Capture and Compression facilities site was 10 feet above mean sea level (MSL) prior to site preparation activities. The natural topographic elevations ranged from 2 feet to 11 feet above MSL. The proposed CO₂ pipeline route is located within 100-year floodplains of the Calcasieu River. At the West Hastings research MVA site, areas identified as Special Flood Hazard Areas inundated by 100-year floods (Zones A, AE, and AO) occur within short distances of Chigger Creek and Cowart Creek.

Wetlands

Wetlands in the area include emergent marshes, bald cypress swamps, and mixed forested wetlands associated with the floodplains of Bayou D'Inde and the Calcasieu River. Prior to site preparation, the LCCE Gasification plant site contained 26.2 acres of cypress-tupelo and emergent freshwater marsh, along with 2,200 linear feet of riverine shoreline (URS 2010). Based on the wetland delineation and USACE jurisdictional determination, the Port of Lake Charles received a permit to construct a facility on the 70-acre LCCE Gasification plant site. The Port of Lake Charles addressed wetland impacts through off-site mitigation banking of 26.2 acres of the wetlands through an agreement with Stream Wetland Services, LLC. No wetlands occur within the West Hastings Research MVA Program area.

Groundwater

The Chicot aquifer serves as the principal source of freshwater for industries and agriculture throughout most of Calcasieu Parish. The 700-foot sand (the Williana Formation) supplies drinking water to the City of Lake Charles as well as some farms and industrial plants in southern and central Calcasieu Parish. Although the majority of the population obtains drinking water from public supply wells, about 26,000 people in the parish obtain drinking water from private domestic wells (USCB 1993). About 3,200 private domestic wells in Calcasieu Parish are screened in the Chicot aquifer system and currently registered as operable (USGS 2011).

In Texas, this aquifer provides water to all or parts of 54 counties, including Brazoria County. In Brazoria County, Texas, the Evangeline and the Chicot aquifers are the only hydrologic units bearing fresh (less than 1,000 milligrams per liter dissolved solids) or slightly saline water (1,000-3,000 mg/l dissolved solids) (Sandeem and Wesselman 1973). The quality of groundwater from these wells is generally good, with total dissolved solids ranging from approximately 480 to 950 mg/L. A total of 65 wells are located within 2 miles of the site including public, industrial, irrigation, domestic, plugged or destroyed, dewatering, commercial, and unused. All groundwater wells are completed into the Chicot aquifer at depths ranging from approximately 20 to 800 feet.

Vegetation

The major vegetation communities of the Lake Charles region include coastal dunes and marshes, coastal prairie and grasslands, pine flatwoods and savannas, mixed wetland uplands and bottomland, and hardwood forests of the Gulf Coast Prairies and Marshes Ecoregion.

Approximately 388 acres of bottomland forest habitat and open marsh occur along the Calcasieu River floodplain about two miles to the southeast. Further south of the urban and agricultural developments associated with the towns of Carlyss and Prien, broad expanses of floodplain and forested habitat extend along both sides of the Calcasieu River. The land proposed for water supply and hydrogen pipeline routes supports native upland and wetland forest, marsh, and urban areas with a mix of non-native and ornamental vegetation. The land proposed for the CO₂ pipeline routes (primary and alternative) supports upland and wetland forest, urban vegetation, and marsh. The primary habitat types crossed by the water supply, hydrogen, and CO₂ pipeline routes are forested wetlands, evergreen forest, and shrub/scrub.

The proposed West Hastings Research MVA Program would be located in the Bluestem Grassland Vegetation Type of the Coastal Prairies of Oak-Prairie Wildlife District of the Gulf Coastal Plain province (TPWD 2011). Today, less than 1% of the native prairie remains, with much of the remainder converted to improved pasture or rice, sugarcane, forage, and grain crops.

Wildlife

The diverse habitats along the Calcasieu River and Bayou d'Inde support a wide variety of terrestrial wildlife in the Lake Charles region. The Cameron Prairie and Sabine National Wildlife Refuges (NWRs), located approximately 20 miles to the southeast and southwest of the project site, respectively, support more than 265 bird species. The most abundant include several species of ducks and geese, which spend the winter on area marshes and forested wetlands.

The vegetative communities of the West Hastings Research MVA area favor the presence of terrestrial wildlife that is tolerant of human disturbance and species that are more generalists in terms of habitat requirements.

Aquatic Ecology

Essential Fish Habitat in the Lake Charles region includes Bayou d'Inde, the Houston River and Calcasieu River, and their associated wetlands. The red drum (*Sciaenops ocellatus*) is managed under the EFH in the Gulf of Mexico and known to have a winter range that extends into the Calcasieu River (NOAA 2011).

The aquatic ecology of the West Hastings Research MVA site includes the two nearby streams of Cowart Creek and Chigger Creek and scattered stock tanks, or man-made ponds. No unique aquatic habitats occur within or near the boundaries of the West Hastings Research MVA site.

Threatened and Endangered Species

Four threatened and endangered species occur or are believed to occur within the Calcasieu Parish: red-cockaded woodpecker (*Picoides borealis*, state and federally endangered); Louisiana black bear (*Ursus americanus luteolus*, state and federally threatened), bald eagle (*Haliaeetus leucocephalus*, state threatened), and Sprague's pipit (*Anthus spragueii*, federal candidate species). No habitat conditions are present to support the listed threatened and endangered species near the LCCE Gasification plant; however, forested areas adjacent to the proposed pipelines routes may provide habitat for the red cockaded woodpecker.

In addition to the species identified above, one state-imperiled species, the old prairie crawfish (*Fallicambarus macneesei*); and nesting colonies of colonial wading bird species, which are protected by the Migratory Bird Treatment Act (MBTA), potentially occur in Calcasieu Parish (USFWS 2011). Field surveys conducted from mid-April through September 2011 did not identify burrows or presence of the old prairie crawfish along the route. The Great blue heron (*Ardea herodias*), yellow-crowned night heron (*Nycticorax nycticorax*), snowy egret (*Egretta thula*), and white ibis (*Eudocimus albus*) were observed along the CO₂ pipeline route during the 2011 field surveys conducted from mid-April through September.

Of the Texas and federally listed endangered or threatened species, none are likely to occur in the area of the West Hastings oil field.

Cultural Resources

No National Register of Historic Places (NRHP)-listed or NRHP eligible archaeological resources occur within a 0.5-mile radius of the LCCE Gasification plant and the Lake Charles CCS project CO₂ Capture and Compression facilities. Cultural resource surveys performed for the gasification plant site in 2009 identified Site 16CU29, a prehistoric shell midden site, dating to ca. 100 B.C. to A.D. 700 (Handly 2009). Results of the field assessment indicated that the area in the vicinity of the archaeological site appeared "to have been heavily impacted by storm surge associated with Hurricanes Rita (in 2005) and Ike (in 2008), as represented by the significant amount of debris that was deposited in the project area" (Handly 2009). The Louisiana SHPO concurred that Site 16CU29 was not NRHP-eligible and that no further investigations were necessary (Hutcheson 2009). A Phase IA cultural resources investigation within the APE for offsite activities associated with the LCCE Gasification plant, including the raw water, potable water, hydrogen, natural gas, and methanol and sulfuric acid pipelines, the electric transmission line, and the construction parking area, identified five previously recommended NRHP-eligible sites and four prehistoric shell midden sites. In August 2012, DOE submitted the reports for the Phase IA cultural resources investigations within the area of potential effects (APE) for the offsite activities to the Louisiana SHPO for review and comment (Fayish 2012). In January 2013, the Louisiana SHPO reviewed the Phase IA cultural resources investigations and concurred with the conclusions and recommendations of the report, including the conclusion that previously surveyed areas or areas that have been identified as disturbed areas do not require any further investigation. The Louisiana SHPO recommended that areas determined to have a high probability for the presence of archaeological resources should be tested according to the Louisiana SHPO's archaeological investigation standards for high

probability areas. No previously identified architectural resources that are listed or determined eligible for listing in the NRHP, including National Historic Landmarks, are located within the APE.

No NRHP-listed or NRHP eligible archaeological resources or historic properties occur within a 0.5-mile radius of the CO₂ pipeline. No previously identified historic properties that are listed on the NRHP, including National Historic Landmarks (NHLs), are located within the APE of the CO₂ pipeline. A Phase I cultural resources investigation of the APE identified one cultural resource, the Hardey Family Cemetery. The Hardey Family Cemetery is a small modern cemetery established in 1988 with two interments (Watkins and Futato 2011). The Louisiana SHPO reviewed the results of the Phase I cultural resources survey and concurred that if the proposed CO₂ pipeline was directionally drilled beneath the Hardey Family Cemetery, no historic properties would be impacted by the proposed CO₂ Pipeline and no further work would be necessary for the CO₂ Pipeline (Breux 2012).

No NRHP-listed or NRHP eligible archaeological resources occur within the APE for the West Hastings Research MVA.

Land Use

The LCCE Gasification plant site is zoned heavy industrial; adjoining and surrounding properties are occupied by refinery operations, chemical facilities, the Port of Lake Charles Bulk Terminal No. 1, and the Lake Charles Coke Handling Terminal. Land use in the vicinity is predominantly wetlands and developed areas, including heavy industrial and petrochemical development. Land use within a 1-mile radius consists primarily of herbaceous wetlands, open water associated with the Calcasieu River, high-intensity development, and woody wetlands. The closest identified residences are approximately 0.75 miles north of the site. Areas within the city of Lake Charles zoned for residential development are located approximately 1.2 to 1.8 miles to the east and southeast, across the Calcasieu River and Prien Lake.

Land use within 1 mile of the CO₂ pipeline consists primarily of developed industrial and residential areas, evergreen forest, and woody wetland areas. The proposed CO₂ pipeline route is located in a rural, sparsely populated area, and includes eight residences within 50 feet of the ROW.

Land uses within the Hastings Oil Field include farmland, rural development, and recreational, commercial, and residential areas. Land uses within the West Hastings Research MVA consist primarily of dedicated hay pasture, low-intensity development, cultivated crops, and shrub/grasslands, along with pockets of deciduous forest and wetlands. BP Pipelines, Conoco Phillips, Enterprise Products, Exxon Mobil GGS, Kinder Morgan, Tejas, Texas Eastern Transmission, TexCal Energy, and several other companies own and operate pipelines in the Hastings Oil Field.

Socioeconomics and Environmental Justice

The population of the city of Sulphur, Louisiana, was 20,410 in 2010, representing a decrease of approximately 0.5% since 2000. In contrast, the total population of Calcasieu Parish as a whole grew by approximately 5.0% since 2000. The city of Sulphur contains 9,053 housing units, of which 15.7% are vacant rental units and 1.6% are otherwise vacant. Per capita income in the city of Sulphur was \$23,450 in 2009 (USCB 2009). This amount is similar to the per capita income

in Calcasieu Parish (\$23,514) but greater than that of the State of Louisiana as a whole (\$22,535) (USCB 2009). The environmental justice analysis consists of the 22 census tracts within an approximately 1-mile radius of the LCCE Gasification plant and Lake Charles CCS project CO₂ Capture and Compression Facilities. Within the study area, 7.6% of the population lives below the poverty level, lower than the state (18.7%), parish (16.5%), and City of Sulphur (15.3%) levels. The population consists of 4.8% minorities, below the state (37.5%), parish (29.2%), and City of Sulphur (10.2%) levels. Therefore, the study area would not be considered an environmental justice area.

The environmental justice analysis within a 1-mile radius of the proposed CO₂ Pipeline route consists of 211 census block groups within Calcasieu Parish and the City of Sulphur. Within the study area, 13.2% of the population lives below the poverty level, lower than the state (18.7%), parish (16.5%), and City of Sulphur (15.3%) levels. The population consists of 18.6% minorities, below the state (37.5%) and parish (29.2%) levels, and above the City of Sulphur (10.2%) level. The study area as a whole is not considered an environmental justice area.

An analysis of the West Hastings research MVA site shows that the cities of Alvin and Pearland are significantly more densely populated than Brazoria County or the State of Texas (USCB 2010). The city of Pearland has 33,169 housing units, of which 12.2% are vacant rental units and 2.1% are otherwise vacant. The 2009 per capita income in the city of Alvin was \$21,001, which is less than the 2009 per capita income in Brazoria County and the State of Texas (USCB 2009). In contrast, per capita income in the city of Pearland is considerably higher at \$33,984 (USCB 2009). The environmental justice analysis consists of 259 census tracts within an approximately one-mile radius of the proposed West Hastings Research MVA site. Within the study area, 13.7% of the population lives below the poverty level, which is lower than the state (16%) and above the county (5%) levels. The population consists of 47.3% minorities, significantly above the state (29%) and county (30%) levels. Therefore, the West Hastings Research MVA study area is considered an environmental justice area.

Traffic and Transportation

Roadways near the project area that would be used for the transportation of personnel, materials, and equipment include Interstate 10 (I-10), State Highway 27, State Highway 1256 (Ruth Street), State Highway 108, and Bayou D'Inde Road. Interstate 10 would provide primary regional access to the site. State Highway 108, a four-lane minor arterial highway, would link the site to the I-10 corridor. Ruth Street, also a two-lane rural major collector, provides a north-south connection from Sulphur and communities to the north to I-10 and Highway 108. The roadways experience acceptable Level of Service (LOS), with the exception that I-10 exhibits a LOS of F from the I-210 through the I-10 interchange, and west along I-10 across the I-10 Calcasieu River Bridge to Lake Charles. The high volume of traffic utilizing the I-10 corridor reflects the presence of numerous multi-modal ports, refineries, and chemical plants located in southeastern Texas and southwestern Louisiana. State Highway 1256 (Ruth Street) exhibits an LOS of E, or extreme congestion, near Patch Street because Ruth Street transitions from a four-lane to a two-lane roadway in that vicinity.

Major roadways providing access to the West Hastings Research MVA site include State Highway 35, County Road 128, and State Highway 6. State Highway 35 is a paved, four-lane highway. These roadways generally experience relatively low traffic volumes and minor roadway congestion.

Noise

Existing dominant noise sources near the proposed site mainly consist of material delivery traffic on Bayou D'Inde Road, industrial operations along Bayou D'Inde Road and Cities Service Highway, rail traffic on the delivery rail line along Bayou D'Inde Road, and material-handling equipment associated with barge deliveries on the Calcasieu River. Sound level measurements indicated that L_{eq} of 60 dBA and L_{90} of 53 dBA were mostly dominated by the traffic noise (industrial/commercial trucks) on Bayou D'Inde Rd and noise from the industrial facilities around the area (ATCO 2012).

Background noise near the Hastings Oil Field reflects levels typical to rural farmlands, suburban areas, and residential neighborhoods, as well as historical oil operations. There are approximately 61 residences located in the West Hastings Research MVA program area within the existing commercial EOR operations area.

Human Health and Safety

The largest population area near the LCCE Gasification site is the city of Lake Charles, Louisiana, approximately 1 mile from the site, across the Calcasieu River. The next nearest large population areas, both with more than 50,000 residents, are the cities of Beaumont, Texas, and Lafayette, Louisiana, which are approximately 70 and 60 miles from the site, respectively. Smaller cities and communities within 2 miles of the project site include Sulphur, Prien, Carlyss, and Westlake, Louisiana. The proposed CO₂ pipeline would be located in a rural, sparsely populated area; eight residences were identified within 50 feet of the ROW.

The largest population areas near the West Hastings research MVA site are cities of Alvin and Pearland, which have populations of more than 25,000. Alvin and Pearland are located approximately 4 miles south and 3 miles north, respectively, from the West Hastings research MVA site, with outlying subdivisions and residential areas nearer to the site.

Wastes and Materials

No past hazardous materials or hazardous waste treatment, storage, or disposal facilities were identified at the LCCE Gasification plant site, and no hazardous materials or hazardous wastes are currently stored, treated, or disposed of at the site. Leucadia would assess the presence of past or current hazardous materials, non-hazardous waste, or hazardous waste treatment generation, storage, or disposal facilities at the equipment laydown and methanol and sulfuric acid storage area, and along the water supply and hydrogen pipeline routes prior to construction at these locations. Three EPA-regulated contaminated sites were identified along the proposed CO₂ pipeline route.

No hazardous waste sites or spills were identified within the West Hastings Research MVA site boundary (EPA 2011).

S-4 Environmental Consequences

DOE evaluated the potential impacts of the proposed action and the no action alternative in relation to the baseline conditions described in Chapter 3 and summarized above. Table S-3 summarizes the potential impacts on each resource area for the proposed project, alternative

Table S-3 Summary of Unavoidable Environmental Impacts

Resource Area	Lake Charles CCS Project (Proposed Action)				LCCE Gasification (Connected Action)
	CO ₂ Capture and Compression	Proposed CO ₂ Pipeline Route	Alternative CO ₂ Pipeline Route	West Hastings Research MVA	Gasification Plant Site and Off-site Activities
Climate and Air Quality	<i>Included in LCCE Gasification</i>	<p>Construction: Negligible Fugitive dust and vehicle and construction equipment emissions would be temporary and have negligible impacts on air quality.</p> <p>Operation: Negligible Vehicle emissions would have temporary, negligible impacts on air quality.</p>	<p>Construction: Same as proposed route</p> <p>Operation: Same as proposed route</p>	<p>Construction: Not applicable</p> <p>Operation: Negligible Fugitive dust and vehicle emissions would have temporary, negligible impacts on air quality.</p>	<p>Construction: Negligible Fugitive dust and vehicle and construction equipment emissions would be temporary and would not affect maintaining attainment with the ozone standard.</p> <p>Operation: Negligible For all criteria pollutants, maximum modeled concentrations would not cause or contribute to any violation of the ambient air quality standards. The transport of petroleum coke would result in a reduction in emissions during shipment of 0.5 million tons per year of petroleum coke diverted.</p>
Geology and Soils	<i>Included in LCCE Gasification</i>	<p>Construction: Minor Soil disturbance and stockpiling could be subject to erosion from both wind and water. Approximately 107 acres of prime farmland would be temporarily affected.</p> <p>Operation: Negligible Any areas of soil exposed during construction of the CO₂ pipeline would be returned to their original condition and usage.</p>	<p>Construction: Same as proposed route</p> <p>Operation: Same as proposed route</p>	<p>Construction: Not applicable</p> <p>Operation: Minor Approximately 4.6 million tons of CO₂ would be sequestered in a portion of the West Hastings oil field.</p>	<p>Construction: Negligible Soil disturbance and stockpiling could be subject to erosion from both wind and water. Approximately 32 acres and 79 acres of prime farmland would be temporarily affected by the water supply and hydrogen pipeline construction, respectively.</p> <p>Operation: Minor Minor spills or leaks from vehicles and material storage areas could impact soils.</p>

Table S-3 Summary of Unavoidable Environmental Impacts

Resource Area	Lake Charles CCS Project (Proposed Action)				LCCE Gasification (Connected Action)
	CO ₂ Capture and Compression	Proposed CO ₂ Pipeline Route	Alternative CO ₂ Pipeline Route	West Hastings Research MVA	Gasification Plant Site and Off-site Activities
Surface Water, Floodplains, and Wetlands	<i>Included in LCCE Gasification</i>	<p>Construction: Minor The proposed CO₂ pipeline would cross Bayou D'Inde and the Houston River using HDD construction methods. Pipeline route would potentially permanently impact 9.98 acres and temporarily impact 9.02 acres of wetland and permanently impact 14.98 acres and temporarily impact 13.23 acres of 100-year floodplain. Approximately 550,100 gallons of water for hydrostatic testing of the pipeline would be obtained from local water bodies or purchased from municipal supplies.</p> <p>Operation: Negligible Periodic maintenance and vehicle traffic would occur.</p>	<p>Construction: Minor The alternative CO₂ pipeline would cross two major waterbodies; impact 26.3 acres of wetland and permanently impact 16.67 acres and temporarily impact 14.57 acres of 100-year floodplain.</p> <p>Operation: Negligible Periodic maintenance and vehicle traffic would occur.</p>	<p>Construction: Not applicable</p> <p>Operation: Negligible Use of existing wells for groundwater monitoring may require dewatering of the wells; produced water would be re-injected into an existing disposal well.</p>	<p>Construction: Minor Construction may introduce contaminants to storm water runoff through excavation, material delivery and storage, concrete washout, waste generation, and equipment and vehicle use and storage. Wetland impacts were addressed through off-site mitigation banking of 26.2 acres of wetlands. Water required for construction of the parking area would include one water truck supplying an average of 2,000 gallon per day for 3 years. Additional floodplain and wetland impacts may occur at the 40-acre site of the equipment laydown area and methanol/sulfuric acid storage are dependent on the final location selected.</p> <p>The water supply pipeline would cross Bayou d'Inde and Bayou Verdine and impact 3.55 acres of wetlands. The hydrogen pipeline would cross Bayou d'Inde, the Sabine River Canal, and two additional waterbodies using HDD construction methods and impact 3.59 acres of wetlands. Hydrostatic testing of the water supply and hydrogen pipelines would approximately require approximately 193,600 and 412,890 gallons, respectively.</p> <p>Operation: Negligible Operation would use an annual average maximum of 8,500 GPM, or 12.2 million gallons per day of raw water from Sabine River. Wastewater, including cooling tower blowdown, water treatment reject, and plant drains and would be discharged as directed by the LDEQ LPDES Water Discharge Permit.</p>

Table S-3 Summary of Unavoidable Environmental Impacts

Resource Area	Lake Charles CCS Project (Proposed Action)			LCCE Gasification (Connected Action)	
	CO ₂ Capture and Compression	Proposed CO ₂ Pipeline Route	Alternative CO ₂ Pipeline Route	Gasification Plant Site and Off-site Activities	
Groundwater	<i>Included in LCCE Gasification</i>	<p>Construction: Negligible HDD would intersect the shallow unconfined aquifer of the Calcasieu River basin. Area impacted by construction is small compared to the greater than 2 million acres size of the shallow groundwater recharge area. Small, incidental drips and leaks of fuels or lubricants could occur from construction equipment or vehicles.</p> <p>Operation: Negligible Small, incidental drips and leaks of fuels or lubricants could occur during maintenance.</p>	<p>Construction: Same as proposed route</p> <p>Operation: Same as proposed route</p>	<p>Construction: Not applicable</p> <p>Operation: Negligible Small, incidental drips and leaks of fuels or lubricants could occur during maintenance.</p>	<p>Construction: Negligible HDD for the water supply and hydrogen pipelines would intersect the shallow unconfined aquifer of the Calcasieu River basin. Area impacted by construction is small compared to the greater than 2 million acres size of the shallow groundwater recharge area. Small, incidental drips and leaks of fuels or lubricants could occur from construction equipment or vehicles.</p> <p>Operation: Negligible Small, incidental drips and leaks of fuels or lubricants could occur from vehicle traffic.</p>
Biology	<i>Included in LCCE Gasification</i>	<p>Construction: Minor Pipeline construction would affect 10.21 acres of forest, 17.65 acres of scrub-shrub, and 2.1 acres of herbaceous grassland habitats. Biological surveys identified potential and confirmed colonial wading bird nesting area locations east of the proposed CO₂ pipeline corridor.</p> <p>Operation: Negligible Long-term maintenance of the hydrogen pipeline, if it occurs during the breeding season, could cause temporary noise and dislocation of colonial wading birds and species, if present in adjacent forested habitats</p>	<p>Construction: Minor Construction would involve five additional waterbody crossings, and impact 26.29 acres of wetland habitat (versus 2.87 acres for the proposed route). Potential habitat exists for the Crested caracara (Caracara cheriway).</p> <p>Operation: Negligible Long-term maintenance could cause temporary noise and dislocation of colonial wading birds and species, if present in adjacent forested habitats.</p>	<p>Construction: Not applicable</p> <p>Operation: Negligible Reworking of existing wells and use of existing roads would involve the temporary use of truck-mounted equipment.</p>	<p>Construction: Minor Approximately 70 acres of previously disturbed, industrial developed, open space land would be impacted. Clearing of the equipment laydown area could remove 40 acres of potential forested habitat. The water supply pipeline corridor would impact 18.47 and 62.74 acres, respectively of forest habitat potentially used by the red-cockaded woodpecker. Suitable habitat for colonial wading birds may be present along the pipeline route intersections with Bayou D'Inde and around the Houston River.</p> <p>Operation: Negligible Long-term maintenance of the hydrogen pipeline, if it occurs during the breeding season, could cause temporary noise and dislocation of colonial wading birds and species, if present in adjacent forested habitats.</p>

Table S-3 Summary of Unavoidable Environmental Impacts

Resource Area	Lake Charles CCS Project (Proposed Action)				LCCE Gasification (Connected Action)
	CO ₂ Capture and Compression	Proposed CO ₂ Pipeline Route	Alternative CO ₂ Pipeline Route	West Hastings Research MVA	Gasification Plant Site and Off-site Activities
Cultural Resources	<i>Included in LCCE Gasification</i>	<p>Construction: Minor Archaeological site 16CU73 would be destroyed. Directional drilling beneath the cemetery, at a minimum depth of 25 feet below the surface of the Hardey cemetery. Cemetery owners have indicated no objection.</p> <p>Operation: Minor The presence of the buried pipeline may alter the setting of the cemetery.</p>	<p>Construction: Not applicable No CR surveys done for alternative route. If alternative route selected as the preferred alignment for the CO₂ pipeline, Denbury would conduct CR surveys.</p> <p>Operation: Not applicable (see above)</p>	<p>Construction: Not applicable</p> <p>Operation: None</p>	<p>Construction: Minor Destruction of the portion of archaeological site 16CU29 that is within the APE during ground disturbance associated with clearing, site preparation, and building activities.</p> <p>Operation: None</p>
Land Use	<i>Included in LCCE Gasification</i>	<p>Construction: Negligible Construction would cause short term impacts to 50.62 acres of temporary ROW which would be restored to previous conditions and uses. 56.34 acres would be impacted long-term, including 8.27 acres of forested land with 2.98 acres of forested wetland.</p> <p>Operation: Negligible Operation of the CO₂ pipeline would require that the area remain clear of woody vegetation and development. Where the pipeline ROW crosses private property, operation of the CO₂ pipeline would restrict landowner uses within the permanent pipeline ROW. Occasional maintenance may require access to buried portions of the pipeline.</p>	<p>Construction: Negligible Construction would impact a total of 187 acres of land, including permanent impacts on 72 acres.</p> <p>Operation: Negligible Same as identified for the proposed route.</p>	<p>Construction: Not applicable</p> <p>Operation: Negligible The research MVA activities are consistent with the existing commercial EOR operation land use.</p>	<p>Construction: Minor The gasification plant would impact 70 acres of industrial property. The raw water pipeline would impact a total of 122 acres of land, including 24 acres of permanent ROW and 98 acres of temporary ROW. The hydrogen pipeline (excluding additional temporary workspace and contractor work sites not within the ROW) would impact a total of 77 acres of land, including 51 acres of permanent ROW and 26 acres of temporary ROW. Surrounding residents and businesses may experience temporary traffic congestion and increased noise and dust levels.</p> <p>Operation: Negligible Occasional maintenance may require access to buried portions of the water supply and hydrogen pipelines.</p>

Table S-3 Summary of Unavoidable Environmental Impacts

Resource Area	Lake Charles CCS Project (Proposed Action)			LCCE Gasification (Connected Action)	
	CO ₂ Capture and Compression	Proposed CO ₂ Pipeline Route	Alternative CO ₂ Pipeline Route	West Hastings Research MVA	Gasification Plant Site and Off-site Activities
Socioeconomics and Environmental Justice	<i>Included in LCCE Gasification</i>	<p>Construction: Minor Construction would require an average of 100 workers, with 250 workers at peak. Demand for temporary housing such as hotel/motel rooms, RV sites, and other rental properties would increase providing a benefit to local providers. The area as a whole is not considered an environmental justice area; however certain census tracts have significantly higher proportions of minority and/or Hispanic populations and populations below the poverty level.</p> <p>Operation: Negligible Two additional workers would be hired to maintain and operate the proposed pipeline route. The workers would be hired locally and would not impact the total population in the Greater Lake Charles area.</p>	<p>Construction: Same as proposed route</p> <p>Operation: Same as proposed route</p>	<p>Construction: Not applicable</p> <p>Operation: Negligible An additional 14 jobs for 4 months and seven operations jobs for up to 4 years would be created. Census tracts in the area have a significantly larger proportion of minority and/or Hispanic population than Brazoria County or Texas.</p>	<p>Construction: Minor Construction would temporarily increase employment in the region during the 36-month construction period and would require a peak of 900 workers on site and 2,500 in the surrounding area. The increase in demand for temporary housing would temporarily reduce vacancy rates for such properties throughout the region and would provide short-term economic benefits to owners of temporary housing in the region.</p> <p>Operation: Minor Operation would require 187 new permanent workers. Approximately 90% of these additional workers would be hired from the existing local labor market and 19 permanent workers would relocate to the area.</p>
Traffic and Transportation	<i>Included in LCCE Gasification</i>	<p>Construction: Minor On average, approximately 100 personnel and 10 trucks would access the pipeline route daily during construction.</p> <p>Operation: Negligible Periodic maintenance of the ROW would include mowing and occasional maintenance activities that may require access to buried portions of the utilities.</p>	<p>Construction: Same as proposed route</p> <p>Operation: Same as proposed route</p>	<p>Construction: Not applicable</p> <p>Operation: Negligible Approximately 14 additional personnel would access the West Hastings research MVA area.</p>	<p>Construction: Minor Approximately 900 workers would access the off-site construction parking area daily. Approximately 150 off-site construction vehicles would deliver concrete, asphalt, and equipment to the site daily during peak construction. Use of Ruth Street during peak construction would degrade LOS from E to F, which is the worst operating condition from a traveler's perspective.</p> <p>Operation: Negligible Approximately 187 personnel would access the site during operation. Approximately 81 one-way truck trips would access the site daily to remove waste materials or deliver materials.</p>

Table S-3 Summary of Unavoidable Environmental Impacts

Resource Area	Lake Charles CCS Project (Proposed Action)				LCCE Gasification (Connected Action)
	CO ₂ Capture and Compression	Proposed CO ₂ Pipeline Route	Alternative CO ₂ Pipeline Route	West Hastings Research MVA	Gasification Plant Site and Off-site Activities
Noise	<p>Construction: <i>Included in LCCE Gasification</i></p> <p>Operation: Negligible The compressors contribute 49 dBA at the nearest receptor location.</p>	<p>Construction: Minor Sound levels may exceed EPA and HUD guidelines at some residences during pipeline construction. HDD activities may need to be conducted in the evening or weekends within 165 feet of a residence or noise sensitive area, which is prohibited by Calcasieu Parish and Cameron Parish ordinances without a variance.</p> <p>Operation: Negligible Noise would be generated from equipment and vehicles used during pipeline inspection and maintenance activities.</p>	<p>Construction: Minor Impact similar to proposed route, 10 residences within 50 feet of the line instead of eight.</p> <p>Operation: Negligible Noise would be generated from equipment and vehicles used during pipeline inspection and maintenance activities.</p>	<p>Construction: Not applicable</p> <p>Operation: Negligible Sound levels from operation of a small drill rig and supporting equipment would most likely be imperceptible due to industrial setting.</p>	<p>Construction: Minor Potential sound level assuming two simultaneous pile driving operations at edge of site during plant construction (64 dBA) exceeds EPA day-night average guideline L_{dn} of 55 dBA and ambient background L_{eq} of 60 dBA. Sound level expected to be barely perceptible due to industrial setting.</p> <p>Sound levels from construction of the hydrogen and water supply pipelines may exceed EPA and HUD guidelines. For the water supply pipeline, HDD activities may need to be conducted in the evening or weekends within 165 feet of a residence or noise sensitive area, which is prohibited by Calcasieu Parish ordinances without a variance.</p> <p>Operation: Negligible Leucadia equipment estimated sound level at nearest noise receptor would exceed the EPA L_{dn} of 55 dBA but would not exceed the ambient background L_{eq} of 60 dBA.</p>

Table S-3 Summary of Unavoidable Environmental Impacts

Resource Area	Lake Charles CCS Project (Proposed Action)			LCCE Gasification (Connected Action)	
	CO ₂ Capture and Compression	Proposed CO ₂ Pipeline Route	Alternative CO ₂ Pipeline Route	West Hastings Research MVA	Gasification Plant Site and Off-site Activities
Wastes	<i>Included in LCCE Gasification</i>	<p>Construction: Negligible Following HDD operations, the bentonite slurry would be recycled, spread in upland areas as a soil supplement, if permitted, or removed and disposed of at a local permitted solid waste landfill.</p> <p>Operation: Negligible Waste generation would be limited to periodic ROW maintenance activities including mowing of ground cover, clearing of vegetation, maintenance of access and service roads, and servicing and monitoring of pipeline system components.</p>	<p>Construction: Same as proposed route</p> <p>Operation: Same as proposed route</p>	<p>Construction: Not applicable</p> <p>Operation: Negligible Produced water and light sediment would be pumped into trucks and hauled off site by a licensed contractor for disposal. Excess drilling mud would be collected and stabilized in steel tanks and transported off site to a designated local solid waste landfill per Denbury's current operating practices.</p>	<p>Construction: Negligible Assuming no recycling of construction waste, approximately 2,640 cubic yards of nonhazardous waste and small quantities of hazardous waste would be generated annually during the 3-year construction period, or less than 0.0002% of the available landfill capacity in Calcasieu Parish.</p> <p>Operation: Negligible Assuming no recycling, approximately 65,000 tons (75,000 cubic yards) of nonhazardous waste generated annually during operation represents 0.6% of the total landfill capacity in Calcasieu Parish. Approximately 1,500 cubic yards of potentially hazardous waste would be generated annually during operation, or less than 0.03% of the capacity of the hazardous waste landfills in Calcasieu Parish.</p>
Materials	<p>Construction: <i>Included in LCCE Gasification</i></p> <p>Operation: Negligible Methanol and propylene would</p>	<p>Construction: Minor Construction would require materials such as carbon steel pipe, valves, pumps, fittings, process materials, cathodic protection equipment, controls and monitoring systems. Also, fuel, lubricants, transmission fluids, and oils would be required for the operation and maintenance of equipment and vehicles.</p> <p>Operation: Negligible Supercritical CO₂, which flows like a liquid, would be transported via the pipeline. Fuel, lubricants, transmission</p>	<p>Construction: Same as proposed route</p> <p>Operation: Same as proposed route</p>	<p>Construction: Not applicable</p> <p>Operation: Negligible Materials used include fuels, oils, lubricants, corrosion inhibitors,</p>	<p>Construction: Minor Construction materials would consist of concrete, wood, fuel, and steel. Construction materials and specialized construction equipment are readily available from in-state and regional vendors and fabricators. Locally obtained materials would include crushed stone, sand, and lumber for the proposed facilities and temporary structures. Construction would require small volumes of commercially available chemicals, including paints and cleaners, and materials for operating and maintaining vehicles and equipment (lubricants, transmission fluids, oils).</p> <p>Operation: Negligible Petcoke, fluxant, fuel, aqueous ammonia, and chlorine would be the primary materials used. Operation would use or produce industrial</p>

Table S-3 Summary of Unavoidable Environmental Impacts

Resource Area	Lake Charles CCS Project (Proposed Action)			LCCE Gasification (Connected Action)	
	CO ₂ Capture and Compression	Proposed CO ₂ Pipeline Route	Alternative CO ₂ Pipeline Route	West Hastings Research MVA	Gasification Plant Site and Off-site Activities
	be the primary materials used. CO ₂ would be used or produced. Operation would occur as an integrated component of the LCCE Gasification plant.	fluids, and oils would be required for the operation and maintenance of equipment and vehicles used for routine maintenance and monitoring of the pipeline and pipeline system components.		ready-mix concrete, gravel fill, reinforcing steel, equipment rentals, piping, fittings, valves, and welding materials.	chemicals, including aqueous ammonia, methanol, sulfuric acid, hydrogen, and fuels.
Human Health and Safety	<i>Included in LCCE Gasification</i>	<p>Construction: Negligible An estimated 1.08 OSHA-recordable cases and 0.6 cases with days away would be anticipated during the construction of the CO₂ pipeline based on national incidence rates and 250 employees during the peak construction period. Based on fatality rates for construction and extraction sector, the fatality rate would be below one (0.01) and no fatalities would be expected. It is not expected that the public would be on site or be exposed to chemical or industrial hazards or contaminants that would exceed public health standards.</p> <p>Operation: Negligible An estimated 1.35 OSHA-recordable cases and 1.08 cases with days away would be anticipated during a 30-year life of the pipeline, based on national incidence rates and the estimated number of workers employed during operation of the pipeline.</p>	<p>Construction: Same as proposed route</p> <p>Operation: Same as proposed route</p>	<p>Construction: Not applicable</p> <p>Operation: Negligible Potential health impacts on workers would be typical of those for the ongoing commercial EOR operation and commercial MVA program.</p>	<p>Construction: Negligible An estimated 84 OSHA recordable cases and 46 cases with days away would be anticipated during construction based on national incidence rates and the estimated 900 construction workers employed during peak construction. The public would not have access to the constructions area. Vehicle emissions would not expose sensitive receptors to substantial pollutant concentrations.</p> <p>Operation: Negligible An estimated 62 OSHA-recordable cases and 34 cases with days away would be anticipated during operation based on national incidence rates and the estimated 187 workers employed during the 30-year life of the plant. Based on fatality rates for petroleum refineries, the fatality rate would be below 1 (0.02) and no fatalities would be expected. Air emissions of criteria pollutants and toxic air pollutants do not cause or contribute to any violation of the ambient air quality standards or expose sensitive receptors to substantial pollutant concentrations.</p>

pipeline, and the connected action for construction and operation. Where possible, DOE quantified the potential impacts associated with the proposed action and the connected action. In some cases, it is not possible to quantify impacts; in those cases, a qualitative assessment of potential impacts is presented. The following descriptors are used qualitatively to characterize impacts:

- **Beneficial:** impacts would improve or enhance the resource.
- **Negligible:** no apparent or measurable adverse impact expected or temporary impacts may not be measurable or are not perceptible.
- **Minor:** barely noticeable or measurable adverse impacts on the resource would be expected.
- **Moderate:** noticeable or measurable adverse impacts on the resource would be expected. Mitigation measures would usually be considered for these impacts,
- **Substantial impact:** potential adverse effects that could result in potentially significant impacts despite mitigation measures.

S-5 Potential Cumulative Impacts

DOE addressed the impacts of the Lake Charles CCS project and LCCE Gasification plant which, when added to the reasonably foreseeable impacts of other significant known or proposed projects within the geographic area in accordance with the cumulative impact requirements of NEPA (40 CFR 1508.7). The projects described in Table S-3 are specifically included in the cumulative impacts analysis. DOE identified three cumulative effects issues as having high importance: air quality, GHG emissions, and surface water; and three as having intermediate importance: geology and soils, biology, and traffic and transportation. Air quality is of high importance, not only because of air emissions, but because of the importance of climate change on a global scale. While individual emissions from the proposed project or connected action do not individually warrant a rating of high importance, the overall CO₂ emissions and their capture are important to the project's demonstration of an advanced technology that integrates CO₂ capture into an industrial source and by confirming the sequestration of CO₂ in an underground formations in conjunction with existing EOR operations.

As a result of the cumulative impacts analysis, DOE concluded that the other potential projects in the region would have impacts on most resources that would be substantially separated by distance from the potential impacts of the project. However, the proposed West Hastings Research MVA program could have incremental positive impacts of helping to ensure the long-term economic viability of CO₂ capture activities by confirming storage of CO₂ injected during EOR operations.

S-6 Conclusions

As with the development of any large industrial project, the construction and operation of the Lake Charles CCS project, including the CO₂ capture facility, associated infrastructure and pipelines, and injection and monitoring wells, would impact the surrounding environment. The project could have beneficial impacts to regional socioeconomics and reduce greenhouse gas emissions. During construction, the proposed project could have minor adverse impacts to soils,

surface water, biological resources, land use, noise levels, and traffic conditions; and could have negligible impacts on the remaining resource areas. The LCCE Gasification plant--the connected action-- could have minor adverse impacts to surface water, biological resources, cultural resources, land use, noise levels, and traffic; and could have negligible impacts on the remaining resource areas during construction. During operation, the Lake Charles CCS project--the proposed project-- could have minor adverse impacts to geology and soils, surface water, biological resources, cultural resources, land use, and traffic; and could have negligible impacts on the remaining resource areas. Socioeconomic impacts from additional jobs created would be minor and beneficial impacts

DOE's proposed action would further the objective of the ICCS program by demonstrating an advanced technology that integrates CO₂ capture into an industrial source and by monitoring the sequestration of CO₂ in an underground formation. The proposed action would advance the ICCS program by providing financial assistance to a project able to achieve the program's objectives as established by Congress: demonstrating the next generation of technologies that will capture CO₂ emissions from industrial sources and either sequester or beneficially use the CO₂. DOE believes that accelerated commercial use of these new or improved technologies will help to sustain economic growth, yield environmental benefits, and produce a more stable and secure energy supply. DOE also recognizes the controversies surrounding the continued dependence on fossil fuels and the need to address the associated environmental and climate change challenges related to their continued use. The Lake Charles CCS project would capture and geologically store approximately 4.6 million metric tons per year of CO₂ that would otherwise be emitted to the atmosphere. DOE considers the technological advancement and commercialization of CCS as an important component of maintaining energy supplies while minimizing environmental impacts associated with using fossil fuel resources.

Table S-4 Regional Projects Identified for Consideration in the Cumulative Impacts Analysis

Project (Owner)	Location	Distance from Site (miles)	Status	Description	Additional Information
Lake Charles Export LNG Terminal (Trunkline LNG)	Lake Charles, LA	5.3	Ongoing; FERC Pre-filing request submitted in March 2012	Trunkline LNG Company, a subsidiary of Southern Union Company, has filed a request with FERC to begin the pre-filing review process to build and operate a natural gas liquefaction project in Lake Charles, Louisiana. The project will take natural gas in its gaseous state and convert it into liquefied natural gas (LNG) for shipment to natural gas markets around the world.	http://www.panhandleenergy.com/lakeCharles/lc_regulatory.asp
Westlake Gas-to-Liquids Plant (Sasol)	Westlake, LA	3.75	Ongoing; feasibility study scheduled to be completed by March 2013	Sasol is conducting a study to evaluate the feasibility of constructing a gas-to-liquids (GTL) plant in Westlake, Louisiana, that would convert natural gas to diesel and jet fuel in a cost-efficient and environmentally friendly way.	http://www.sasolgtl.com/page.php?page=westlake_project
Sabine Pass LNG Export Terminal (Chenier Energy)	Cameron Parish, LA	46	Ongoing; FERC authorization issued on April 16, 2012	Cheniere Energy proposes to install liquefaction services at the Sabine Pass LNG receiving terminal in Cameron Parish, Louisiana. Adding liquefaction capabilities will transform the Sabine Pass terminal into a bi-directional facility capable of liquefying and exporting natural gas in addition to importing and regasifying foreign-sourced LNG. The Sabine Pass site can readily accommodate up to four LNG trains capable of processing approximately 2 billion cubic feet per day (Bcf/d) of natural gas.	http://www.cheniere.com/lng_industry/sabine_pass_liquefaction.shtml
Cameron LNG Export Terminal (Sempra Energy)	Cameron Parish, LA	47	Ongoing; FERC Pre-filing request submitted in April 2012	Cameron LNG is obtaining approval from DOE to export up to 12 million metric tons per year, or approximately 1.7 billions of cubic feet per day, of domestically produced liquefied natural gas (LNG) to all current and future Free Trade Agreement countries.	http://cameron.sempralng.com/liquefaction.html

Table S-4 Regional Projects Identified for Consideration in the Cumulative Impacts Analysis

Project (Owner)	Location	Distance from Site (miles)	Status	Description	Additional Information
Lake Charles Harbor and Terminal District	Calcasieu Parish, LA	0	Ongoing	The Port of Lake Charles is the 11 th largest seaport in the U.S. The principal cargoes moving through the port's terminals are bagged rice, flour, and other food products; forest products; aluminum; petroleum coke and other petroleum products; woodchips; barites; and rutile. The port identifies active development projects on its website.	http://www.portlc.com/AboutUs.asp
Hastings Oil Field	Brazoria County, TX	0	Ongoing	DOE awarded a financial assistance grant under the American Recovery and Reinvestment Act of 2009 in the form of a cooperative agreement with Air Products and Chemicals, Inc. (Air Products), as part of the Industrial Carbon Capture and Sequestration (ICCS) program. Air Products' proposed project involves an integrated carbon capture, transport, injection, sequestration, and monitoring program of approximately 1 million tons per year (tpy) of CO ₂ from Air Products' two H ₂ plants in Port Arthur, Texas, for use in CO ₂ EOR at the Hastings oil field.	
West Ranch Oil Field	East of Victoria in Jackson County, TX	100 miles SE	Ongoing	DOE selected NRG for a financial assistance award through a competitive process under the Clean Coal Power Initiative (CCPI) program to demonstrate CCS technologies at coal-fired power plants. NRG is authorized to design, construct, and operate a commercial-scale carbon dioxide (CO ₂) capture facility at its existing W.A. Parish Generating Station (Parish Plant) in Fort Bend County, Texas; deliver the CO ₂ via a new pipeline to the existing West Ranch oil field in Jackson County, Texas, for use in EOR operations; and demonstrate monitoring techniques to verify the permanence of geologic CO ₂ storage. The Draft EIS was issued by DOE.	http://www.netl.doe.gov/publications/others/nepa/deis_sept.html

This page left blank intentionally.

1. Introduction

The U.S. Department of Energy (DOE) prepared this Environmental Impact Statement (EIS) to analyze the potential environmental impacts of providing cost-shared funding to Leucadia Energy, LLC (Leucadia) to implement their proposed project and to inform DOE's decision of whether to provide such funding. The EIS was prepared in accordance with the National Environmental Policy Act (NEPA) of 1969, as amended (NEPA; 42 U.S.C. 4321 et seq.), Council on Environmental Quality (CEQ) regulations (40 CFR Parts 1500 to 1508), and DOE NEPA implementation procedures (10 CFR Part 1021).

The National Environmental Policy Act (NEPA) requires that federal agencies prepare a detailed statement of environmental impacts for **proposed actions** significantly affecting the human environment.

1.1 DOE's ICCS Program

Carbon dioxide (CO₂) is a greenhouse gas that is linked to global climate change. DOE's National Energy Technology Laboratory (NETL) oversees a program to develop technologies that capture and store or beneficially use CO₂ that would otherwise reside in the atmosphere for extended periods. These technologies for carbon capture and sequestration (CCS) have significant potential to reduce CO₂ emissions and thereby mitigate global climate change, while minimizing the economic impacts of the solution. The Industrial Carbon Capture and Sequestration (ICCS) program specifically targets technologies to reduce man-made (anthropogenic) CO₂ emissions from industrial sources.

Projects funded under the ICCS program are cost-shared collaborations between the government and industry to increase investment in clean industrial technologies, CCS, and beneficial use projects. Under the ICCS funding opportunity, industrial firms proposed projects to meet their needs and those of their customers while furthering the national goals and objectives of DOE. The successful development of advanced technologies and innovative concepts that reduce emissions of CO₂ is a key objective of the nation's effort to help mitigate the effects of climate change. The technologies included in the ICCS program have progressed beyond the research and development stage to a scale that can be readily replicated and deployed into commercial practice within the industry.

1.1.1 Legislative History

In Section 703 of the Energy Independence and Security Act of 2007 (Pub. L. 110-140), Congress directed DOE to "carry out a program to demonstrate technologies for the large-scale capture of carbon dioxide from industrial sources." Accordingly, DOE subsequently sought applications in a funding opportunity announcement (FOA) entitled "Carbon Capture and Sequestration from Industrial Sources and Innovative Concepts for Beneficial CO₂ Use" on June 8, 2009 (Financial Assistance Funding Opportunity Number DE-FOA-0000015, amended July 17, 2009). Congress appropriated funding for ICCS in the American Recovery and Reinvestment Act of 2009, Public Law 111-5 (Recovery Act) to stimulate the economy and reduce unemployment, in addition to furthering DOE's existing CCS objectives. Accordingly, special consideration was given to projects that promote job creation, job preservation, and economic recovery in an expeditious manner.

1.1.2 Project Selection Process

DOE’s two specific objectives identified in the FOA were Technology Area 1—Large-Scale CCS Projects from Industrial Sources; and Technology Area 2—Innovative Concepts for Beneficial CO₂ Use. Technology Area 1 focuses on the demonstration of advanced technologies that capture and sequester CO₂ emissions from industrial sources into underground formations or put the CO₂ to beneficial use in a manner that permanently prevents it from entering the atmosphere. Technology Area 1 includes expanding CO₂ use in enhanced oil recovery (EOR) and obtaining information on the cost and feasibility of deploying sequestration technologies. Under the FOA, DOE sought projects with technologies that have progressed beyond the research and development stage to a point of readiness for operation at a scale that, if successful, could be readily replicated and commercially deployed. The proposed Lake Charles Carbon Capture and Sequestration Project (Lake Charles CCS project) was one of three projects DOE selected under Technology Area 1, as shown on Figure 1.1-1. The proposed Lake Charles CCS Project and the Air Products and Chemicals, Inc. Demonstration of CO₂ Capture and Sequestration of Steam Methane Reforming Process Gas Used for Large Scale Hydrogen Production (DOE/EA-1846) project would both sequester CO₂ emissions in a portion of the Hastings oil field in Texas at an existing EOR operation.

Project Locations for ICCS Area 1 Large-Scale Industrial Carbon Capture & Sequestration



Figure 1.1-1 Project Locations for ICCS Technology Area 1

DOE initially selected 12 applicants who met the minimum eligibility requirements for the FOA and the objectives of the ICCS program. The initial selection process was followed by a project definition phase, in which applicants could further develop their plans. This project definition phase was followed by an opportunity for continuation applications and a second selection process. Eight applicants applied for a continuation of co-funding for their project.

For these eight applications, DOE documented the potential environmental consequences of each project that met the eligibility requirements in an environmental critique and summarized the results in a publicly available environmental synopsis (see Appendix A). DOE prepared this synopsis in accordance with DOE's NEPA regulations (10 CFR Part 1021). Through this review process, DOE considered both the potential environmental consequences and the ability of each project to meet the purpose of and need for action. DOE used the procedures established in its NEPA regulations, specifically those in 10 CFR 1021.216, to identify and consider the potential environmental impacts of the eligible projects in making its selections. The environmental critique and preliminary NEPA determinations for each project were provided to the selecting official for consideration during the selection process. DOE must complete a separate, independent, project-specific NEPA analysis for each of the three selected projects before making a final decision on funding, as described in Section 1.5.1 below.

1.2 DOE's Proposed Action

DOE's proposed action is to provide financial assistance to Leucadia for the Lake Charles CCS Project. DOE proposes to provide Leucadia with up to \$261.4 million of cost-shared financial assistance. The financial assistance would apply to:

- the planning, design, permitting, equipment procurement, construction, startup, and demonstration of the CCS technology,
- an 11.9-mile CO₂ pipeline connecting the plant to the existing Green Pipeline, and
- a research monitoring, verification, and accounting (MVA) program that would provide an accurate accounting of approximately 1 million tons of stored CO₂ and a high level of confidence that the CO₂ injected through the existing, commercial EOR process will remain sequestered permanently in a portion of the West Hastings oil field.

DOE's contribution of \$261.4 million would constitute about 60 percent of the total development and capital cost of the CCS project, which is estimated to be \$435.6 million (2010 dollars). The proposed project would further the objective of the ICCS program by demonstrating an advanced technology that integrates CO₂ capture into an industrial source and by confirming the sequestration of CO₂ in an underground formations in conjunction with existing EOR operations.

The Lake Charles CCS project would contribute significantly to a number of DOE program goals stated in the FOA, including the large scale capture and sequestering of over 4 million tons of CO₂ per year and performing research-focused MVA on over 1 million tons per year of CO₂. Because of the construction schedule of the LCCE Gasification plant, it would not be possible to complete a research MVA program of significant duration using CO₂ from LCCE prior to the September 30, 2015, deadline for expenditure of Recovery Act funds. Therefore, to ensure that adequate research MVA data is received, DOE would allow Leucadia to conduct the research MVA portion of the Lake Charles CCS Project starting in 2013 by monitoring CO₂ from alternate sources. Leucadia and Air Products would jointly fund the research MVA program performed at the West Hastings oil field. This research MVA program at the West Hastings oil field would consist of over 2 million tons/year of CO₂, with both Leucadia and Air Products receiving credit for at least 1 million tons/year and funding half of the non-DOE cost share. Upon operation of the Lake Charles CCS Project, Leucadia would provide DOE with

information necessary to determine whether the commercial-scale technology operations at the LCCE Gasification plant are making progress toward the capture and sequestration of 75% of the CO₂ from the treated stream, comprising at least 10% of CO₂ by volume, which would otherwise be emitted to the atmosphere.

1.3 Purpose and Need for DOE Action

The purpose and need for DOE action is to advance the ICCS program by providing financial assistance to projects that have the best chance of achieving the program's objectives as established by Congress: demonstrating the next generation of technologies that will capture CO₂ emissions from industrial sources and either sequester or beneficially use the CO₂. The proposed project was selected under the ICCS program as one in a portfolio of projects that would represent the most appropriate mix to achieve programmatic objectives and meet legislative requirements.

This proposed project would help DOE, through the ICCS Program, meet its congressionally mandated mission to expedite and carry out large-scale testing of CO₂ sequestration systems. The proposed project would demonstrate the use of advanced technologies to capture CO₂ emissions from an industrial source and sequester them as part of an enhanced oil recovery (EOR) operation. The project would also provide information on the cost and feasibility of deploying sequestration technologies. A successful demonstration of the Rectisol-based carbon-capture technology with beneficial use of the CO₂ at an existing oil field would also generate technical, environmental, and financial data from the design, construction, and operation of the CO₂ capture facility, pipeline, and CO₂ monitoring facilities at the oil field. These data would be used to evaluate whether the deployed technologies could be effectively and economically implemented at a commercial scale.

Congress, through the Energy Independence and Security Act of 2007, directed DOE to expedite and carry out large-scale testing of CO₂ sequestration systems in a range of geologic formations, including the expansion of CO₂ EOR to new settings, while providing information on the cost and feasibility of deployment of sequestration technologies.

1.4 Leucadia's Proposed Project

Leucadia's Lake Charles CCS Project involves the capture and sequestration of CO₂ from Lake Charles Clean Energy, LLC (LCCE Gasification plant), a petroleum coke gasification plant to be constructed in Calcasieu Parish, adjacent to the Port of Lake Charles, Louisiana. Leucadia's LCCE Gasification plant would not receive co-funding from DOE. The Lake Charles CCS Project includes:

- Capture and compression of approximately 4.6 million tons per year of CO₂ emissions at the LCCE Gasification plant;
- Transport of CO₂ via a new pipeline that will connect to the existing Green Pipeline and to existing EOR operations at the West Hastings oil field in Texas; and
- A research MVA program aimed at providing an accurate accounting of approximately 1 million tons of stored CO₂ and a high level of confidence that the CO₂

The Lake Charles CCS Project would demonstrate (1) advanced technologies that capture CO₂ and (2) permanent storage of a portion of the CO₂ injected as part of existing EOR operations.

will remain sequestered permanently in a portion of the West Hasting oil field through existing EOR operations.

Leucadia would capture and compress CO₂ from the LCCE Gasification plant. Denbury Onshore, LLC, is a subcontractor to Leucadia for the transport of CO₂ and for conducting the MVA activities.

Each of the components of the project is described in detail in Chapter 2, The Proposed Action and Alternatives.

1.5 Scope of the Environmental Analysis

NEPA requires all federal agencies to include, in every recommendation or report on proposals for major federal actions that may significantly affect the quality of the human environment, a detailed statement by the responsible agency describing: (1) the potential environmental impacts of the Proposed Action; (2) any adverse environmental effects that cannot be avoided should the proposal be implemented; (3) alternatives to the Proposed Action, including the alternative of taking no action; (4) the relationship between local short-term uses of the environment and the maintenance and enhancement of long-term productivity; and (5) any irreversible and irretrievable commitments of resources that would be involved in the Proposed Action should it be implemented. NEPA also requires consultations with agencies that have jurisdiction or special expertise with respect to any environmental impact involved, and that the detailed statement along with the comments and views of consulted governmental agencies be made available to the public (42 USC 4332).

DOE identified the scope of this EIS based on internal planning and analysis, consultation with federal and state agencies, and the public scoping process. This EIS identifies and analyzes the potential impacts of the proposed action: the co-funding of Leucadia's Lake Charles CCS Project. Though DOE funds would only apply to the CCS Project, DOE determined that the LCCE Gasification plant is a **connected action** in accordance with 40 CFR 1508.25 (a), and its impacts are analyzed in the EIS. This EIS also assesses the potential environmental impacts of project related options and DOE's no-action alternative.

This EIS identifies and analyzes the potential impacts of the most current design information available for the West Hastings research MVA program. As described in Section 1.1.1, DOE also selected for funding under the ICCS Program the Air Products' project: *Demonstration of CO₂ Capture and Sequestration of Steam Methane Reforming Process Gas Used for Large-Scale Hydrogen Production*. Air Products would capture CO₂ from existing hydrogen production plants, transport the CO₂ to the existing Green Pipeline and ultimately to the West Hastings oil field. Denbury is a subcontractor to Air Products and will share responsibility for conducting the research MVA activities. DOE completed an Environmental Assessment (EA) for the Air Products CCS project in June 2011, including the research MVA program that would be jointly funded by Leucadia and Air Products (DOE/EA 1846). In that EA, DOE described the existing environment and analyzed impacts to air quality, water resources, land use, geology and soils, biological resources, cultural resources, socioeconomics, environmental justice, and human health and safety. Since the release of the Air Products EA in 2011, Denbury completed additional design work and additional information is now available on the research MVA program. Because the Air Products ICCS project is proceeding and the West Hastings MVA would be jointly funded by Air Products, some activities and impacts from the West Hastings

MVA program have already occurred. This EIS reflects the most current design information available for the West Hastings research MVA program.

This EIS identifies and analyzes the potential impacts of the most current design information available for the LCCE Gasification plant. Some activities and impacts from the site preparation activities have already occurred and are also evaluated. A jurisdictional wetland determination was conducted by the USACE New Orleans District as part of a USACE permit approval for site development. Based on the wetland delineation and USACE jurisdictional determination, the Port of Lake Charles received a permit, issued on August 18, 2008, to construct a facility on the 70-acre LCCE Gasification plant site. The LCCE Gasification plant site contained 26.2 acres cypress-tupelo and emergent freshwater marsh, along with 2,200 linear feet of riverine shoreline (URS 2010). Cultural resource surveys performed in 2009 identified Site 16CU29, a prehistoric shell midden site, dating to ca. 100 B.C. to A.D. 700 (Handly 2009). Results of the field assessment indicated that the area in the vicinity of the archaeological site appeared “to have been heavily impacted by storm surge associated with Hurricanes Rita (in 2005) and Ike (in 2008), as represented by the significant amount of debris that was deposited in the project area” (Handly 2009). The Louisiana State Historic Preservation Office(r) (SHPO) concurred that Site 16CU29 was not eligible for the National Register of Historic Places (NRHP) and that no further investigations were necessary (Hutcheson 2009). Site preparation activities for the LCCE Gasification plant, including clearing and grading, began in January 2010.

The scope of this EIS does not include current commercial operations, specifically the Green Pipeline and existing EOR operations at the West Hastings oil field. The existing Green Pipeline is an approximately 325-mile, 24-inch-diameter CO₂ pipeline that originates in Jackson Dome, Mississippi, extends westward from near Donaldsonville, Louisiana (south of Baton Rouge), to the West Hastings oil field, and other locations in Texas (Denbury 2011a). The Green Pipeline transports CO₂ to the West Hastings oil field at volumes up to 800 million standard cubic feet per day (MMSCFD). This CO₂ is obtained from anthropogenic (man-made) sources and natural sources (the Jackson Dome, an underground structure containing CO₂) (Denbury 2011a). The Green Pipeline was constructed independent of the proposed project, and affiliates of Denbury would continue to operate the Green Pipeline regardless of DOE’s decision on the proposed action. Denbury uses CO₂ from the Green Pipeline for EOR operations at several oil fields along the southeast Texas Gulf Coast, including the West Hastings oil field (APCI 2011). The CO₂ from the Lake Charles CCS project would supplement or replace other anthropogenic CO₂ and naturally occurring CO₂ taken from the Jackson Dome and used for the existing EOR operation at the West Hastings oil field.

Denbury began CO₂ injections in Block A of the West Hastings oil field on December 16, 2010 (APCI, 2011). Denbury’s existing commercial EOR operations and associated commercial monitoring activities are independent of the proposed project and would occur regardless of the proposed project and DOE’s decision on the proposed action. The injection rates and production volumes would not change as a result of the proposed project and the DOE’s decision on the proposed action. Therefore, these commercial EOR operations and activities are not within the scope of this EIS.

The NEPA review process includes several opportunities for public input during the preparation of the Draft EIS and Final EIS and is summarized in the flow diagram shown on Figure 1.5-1. DOE has distributed the Draft EIS to interested parties and published a Notice of Availability

(NOA) in the Federal Register. A separate NOA was published by the EPA. Beginning with publication of the NOA, DOE established a 45-day public review and comment period on the Draft EIS. During this period, DOE plans to hold public hearings to solicit public comments on the Draft EIS. DOE will consider and respond to all substantive comments received on the Draft EIS, both individually and collectively. DOE will address those comments in a Final EIS, which will be distributed to the public and other stakeholders. Upon DOE’s publication and distribution of the Final EIS, the EPA will publish an NOA in the Federal Register, at which point DOE will observe a minimum 30-day waiting period before issuing an agency decision.

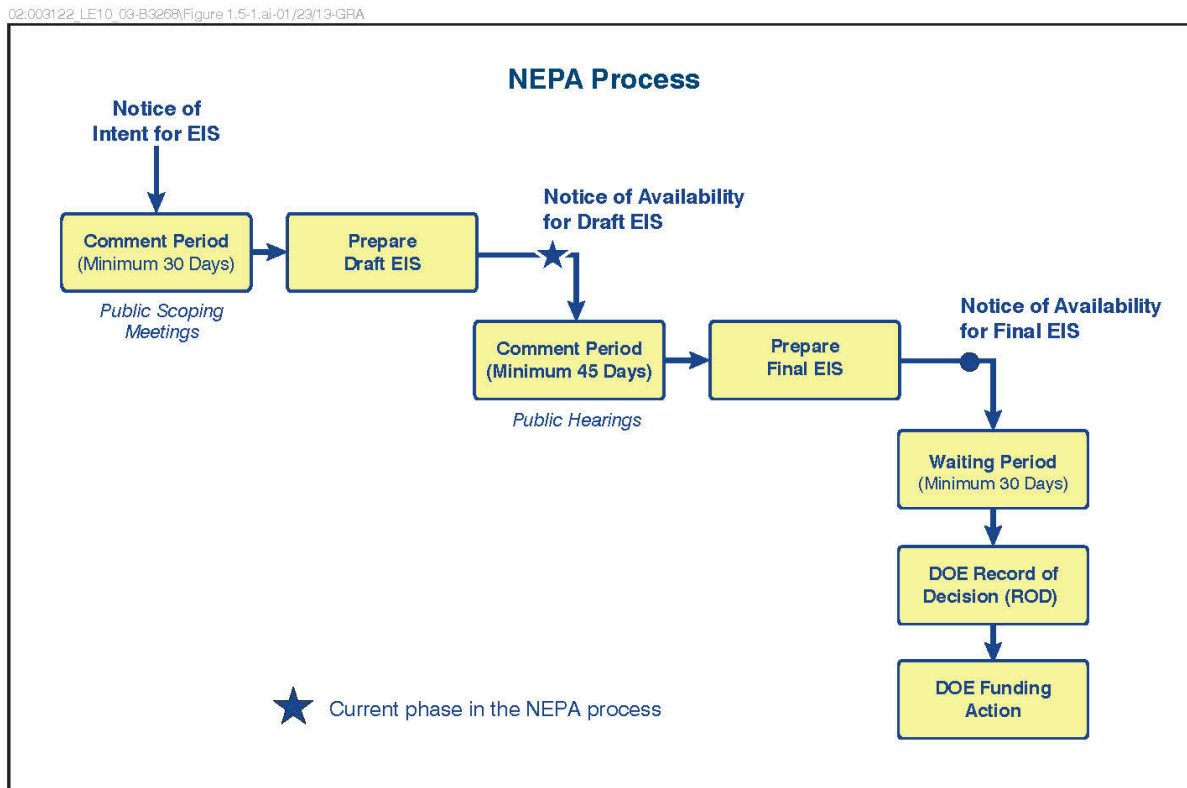

Figure 1.5-1 NEPA Process Flow Chart

Upon completion of the waiting period, DOE will publish a Record of Decision (ROD) in the Federal Register stating the agency’s decision whether to provide financial assistance for the Lake Charles CCS project and documenting any special requirements and mitigation measures, if necessary.

1.5.1 Scoping Process and Public Participation Activities

DOE published a Notice of Intent (NOI) to prepare an EIS for this proposed action in the Federal Register on April 29, 2011 (Federal Register Doc. 2011-10448). The NOI initially informed the public about DOE’s proposed action and Leucadia’s proposed project; announced the public scoping meetings; solicited comments for DOE’s consideration regarding the scope and content of the EIS; provided notice that the proposed project may involve impacts on floodplains and wetlands; and invited those agencies with jurisdiction by law or special expertise to participate as cooperating agencies in the preparation of this EIS.

Following publication of the NOI, DOE notified the stakeholders of the Lake Charles CCS Project through: (1) newspaper notices published in the affected communities on April 29, April 30, May 1, and May 8, 2011; (2) a mailing of 100 postcards on May 2, 2011, to local, state, and federal elected officials and agencies with jurisdictional interest in the project; and (3) posting of all public notifications on Regulations.gov, a federal government website.

The scoping period began with the publication of the NOI on April 29, 2011, and concluded on May 29, 2011. No late comments or requests to extend the comment period were received. Two public scoping meetings were held on May 16 and 17, 2011. The first scoping meeting was held in Pearland, Texas, and the second meeting was held in Westlake, Louisiana. The scoping meetings were a combination of open information exchange and formal public comment. DOE and third-party contractor staff were available for informal discussions with the public from 5:00 P.M. to 7:00 P.M. prior to the formal public comment session, which convened at 7:00 P.M.

1.5.2 Resource Areas Considered and Issues Identified During the Scoping Process

DOE initially identified the following environmental resource areas for consideration in the EIS. This list was not intended to be an all-inclusive or predetermined set of resources to be assessed for potential environmental impacts.

- Air quality resources
- Climate change
- Water resources
- Infrastructure and land use
- Solid wastes
- Ecological resources
- Floodplains and wetlands
- Transportation and traffic
- Historic and cultural resources
- Geology and soils
- Public health and safety issues
- Socioeconomics
- Environmental justice
- Noise
- Cumulative effects

During the scoping period, comments were received from private citizens, businesses, and nongovernmental organizations. A total of 229 comments were received; 109 comments were generated at the scoping meetings and 120 comments were received in the mail. DOE reviewed and evaluated the written and oral comments during the preparation of this DEIS. The environmental resource areas and issues identified prior to and during scoping that received the majority of comments included the following:

- **Purpose of and need for the project:** Commenters expressed concern that the CO₂ being captured would not generate enough economic benefit to justify the federal funds being used for the proposed project.
- **Description of the project:** Commenters were concerned with the change from the production of syngas to the production of methanol in the initial project description that was submitted to DOE. Several commenters expressed concern that Leucadia had neither defined the origin of the petroleum coke nor named the purchaser of the methanol. Commenters were concerned about the specific equipment and daily use of the equipment at the EOR operation, as well as the duration and extent of oil recovery operations.

- **Air quality:** Commenters were concerned with impacts of air emissions from the gasification plant, the transportation of petroleum coke, the expansion of EOR operations, and the ozone non-attainment status of Calcasieu Parish.
- **CO₂ capture and sequestration:** Commenters were concerned that capture and sequestration was not proven and were unclear on the amount of CO₂ that would be captured, and whether overall CO₂ emissions would be reduced, because the CO₂ would be used to produce more oil.
- **Socioeconomics:** Commenters expressed concern about using available local labor during construction and operation of the proposed project and ensuring that workers are paid a fair wage and the balance of environmental impacts with economic benefits.
- **Contamination of land and water resources:** Several commenters expressed concern about existing and potential water, soil, and air contamination in the area of the EOR operations and the Lake Charles gasification plant and the need to assess the current contamination before the proposed project moves forward. They also were concerned about a potential break in the existing Green Pipeline and subsequent CO₂ contamination of local drinking water.
- **Wetland and waterbody impacts:** Commenters expressed concern about impacts on wetlands from the expansion of the CO₂ EOR operation, as well as the loss of wetlands due to the construction of the LCCE Gasification plant and the proposed CO₂ pipeline. Commenters requested information on the water use and wastewater discharges from the LCCE Gasification plant and impacts to the Calcasieu River.
- **Safety:** Commenters expressed concern about potential health and safety risks from a rupture of the CO₂ pipeline and what constituents would be in the pipeline, from well failures in the EOR operation, and from induced earthquakes.
- **Alternatives:** Commenters expressed concern related to alternatives regarding the siting of the LCCE Gasification plant, the use of alternative technologies to reduce air pollution, and alternatives to the CCS technology design or operations to increase the percentage of CO₂ sequestered.
- **Cumulative impacts:** Commenters were concerned with the cumulative impacts of this project in combination with other projects along the existing Green Pipeline for which DOE may be providing funding, including noise, traffic, air quality, importation of petroleum coke, and the capacity of the Green Pipeline to accept additional CO₂.

1.5.3 Alternatives Considered

NEPA requires that an EIS evaluate the range of reasonable alternatives to an agency's proposed action. The range of reasonable alternatives encompasses those alternatives that would satisfy the underlying purpose and need for agency action. Projects included in the ICCS program are those that best demonstrate advanced CCS technologies that are ready for use at a demonstration scale. Once demonstrated, those technologies would be ready for deployment at a commercial scale.

DOE will evaluate the project as proposed by Leucadia, any alternatives still under consideration by Leucadia (e.g., alternative pipeline routes proposed for the project), and DOE's no action alternatives. This EIS briefly describes alternatives previously considered by Leucadia in developing the proposed project; however, DOE does not plan to further analyze these alternatives because they are no longer under consideration by Leucadia and because they were not part of the proposal that Leucadia offered and DOE accepted.

Under the no action alternative, DOE would not provide funding to Leucadia. In the absence of financial assistance from DOE, Leucadia could reasonably pursue several options. Leucadia could build both the LCCE Gasification plant and the Lake Charles CCS project with funding from other sources. DOE assumes that if Leucadia builds the LCCE Gasification plant and Lake Charles CCS project in the absence of DOE cost-shared funding, the plant would include the same features, attributes, and impacts described for the proposed project and connected action. Alternatively, Leucadia could choose not to build all or portions of the LCCE Gasification plant and Lake Charles CCS project. For the purpose of making a meaningful comparison between the impacts of DOE providing and withholding financial assistance, DOE assumed that all or part of the LCCE Gasification plant and Lake Charles CCS project would not be completed without DOE funds. Therefore, the following sub-alternatives were identified and analyzed in the EIS:

1. Neither the LCCE Gasification plant nor the Lake Charles CCS project would be built, or
2. The LCCE Gasification plant would be built, but the captured CO₂ would be vented to the atmosphere and not sequestered in an ongoing EOR operation.

The ongoing commercial CO₂ EOR operations and the West Hastings research MVA program would continue under each of these no action options. In the absence of Leucadia's participation, Air Products would fund the entire non-DOE share of the research MVA program under a separate project agreement.

1.5.4 Incomplete and Unavailable Information

CEQ regulations provide for the inclusion of uncertainties in the EIS analysis, and state that "(w)hen an agency is evaluating reasonably foreseeable significant adverse effects on the human environment in an EIS and there is incomplete or unavailable information, the agency shall always make clear that such information is lacking" (40 CFR 1502.22).

Generally, future permit applications would include detailed plans for minimizing potential impacts to environmental resources, particularly protected species and habitats, including wetlands and waterbodies. Agencies issuing permits would require mitigation to fully offset the impact.

Certain project components are still in design and therefore have not been fully surveyed in the field. These components include the LCCE Gasification plant construction laydown area and water supply and hydrogen pipeline corridors. Due to the lack of specific information on these areas, neither field studies to characterize the routes nor detailed assessments of impacts were possible. However, readily available information on area characteristics was assembled, and potential impacts were qualitatively assessed to the extent possible. The needs for access roads to support linear facilities construction have not been studied, so no assessment of potential impacts that would be associated with new or upgraded roads was possible for this EIS. Despite these

limitations, the existing characteristics of the unsurveyed areas and potential impacts within them because of project related construction would likely be similar to those described in greater detail for the surveyed areas due to similar topographical, ecological, and land use characteristics. Future construction areas would require further characterization of ecological and cultural resources. These further studies would occur closer in time to when construction would occur. For purposes of complying with NEPA, a qualitative assessment using the best information available has been made in this EIS.

This page left blank intentionally

2. Proposed Action and Alternatives

2.1 DOE's Proposed Action

DOE's proposed action is to provide approximately \$261.4 million in cost-shared financial assistance to Leucadia for the Lake Charles CCS project that would:

- Capture and compress CO₂ at the LCCE Gasification plant in Calcasieu Parish, Louisiana,
- Transport CO₂ via a new 11.9 mile-long pipeline that would connect to the existing Green Pipeline, which extends across Louisiana and into Texas, and
- Implement a research MVA program in a portion of the West Hastings oil field in Texas to demonstrate and study CO₂ sequestration through existing EOR operations.

The total cost of the project is approximately \$435.6 million.

As detailed in Section 2.2 below, Leucadia's proposed project would further the objective of DOE's ICCS program by demonstrating advanced technologies that integrate CO₂ capture at industrial sources and monitor the sequestration of CO₂ in underground formations.

This EIS evaluates the environmental and social impacts of DOE providing financial assistance for the Lake Charles CCS project.

2.2 Description of Leucadia's Proposed Project

Leucadia's proposed project would: (1) demonstrate advanced technologies that integrate the capture of CO₂ into an industrial source and (2) provide an accurate accounting of CO₂ stored and a high level of confidence in the permanent sequestration of a portion of the CO₂ injected during existing enhanced oil recovery (EOR) operations.

The Lake Charles CCS project would demonstrate the capture and sequestration of CO₂ from Leucadia's Lake Charles Clean Energy Gasification plant (LCCE Gasification plant). Leucadia would build, own and operate LCCE Gasification plant, a petroleum coke ("pet coke") gasification facility in Calcasieu Parish, adjacent to the Port of Lake Charles, Louisiana. The LCCE Gasification plant and the Lake Charles CCS project are described further below. Figure 2.2-1 illustrates the general locations of the Lake Charles CCS project, the LCCE Gasification plant -- the connected action, as described in Section 1.5-- and the existing commercial EOR operations. The primary components of Leucadia's proposed project are:

1. LCCE Gasification Plant (the Connected Action)

The LCCE Gasification plant would use four General Electric quench gasifiers to convert petroleum coke into syngas. The syngas would be further processed to produce methanol, hydrogen gas, and sulfuric acid, as well as CO₂. The LCCE Gasification plant would provide raw syngas containing CO₂ to the Lake Charles CCS project, where the CO₂ would be separated from the syngas.

2. Lake Charles CCS CO₂ Capture and Compression

The CO₂ capture equipment would consist of two Lurgi Rectisol® Acid Gas Removal (AGR) units in which CO₂ is separated from the process gas. The compression equipment would include two compressors that would pressurize the CO₂ to 2,250 pounds per square inch gauge (psig) for transport and geologic sequestration. Approximately 4.6 million tons per year of CO₂ would be captured from the LCCE Gasification plant.

3. Lake Charles CCS CO₂ Pipeline

Denbury, through an affiliate, would construct, own, and operate the proposed 11.9-mile-long CO₂ pipeline connecting to the existing Green Pipeline, which would transport the captured CO₂ to oil fields, including the West Hastings oil field, in Brazoria County, Texas. The proposed Lake Charles CCS CO₂ pipeline would begin at the proposed CO₂ meter station located at the fence line of the LCCE Gasification plant and would tie into the existing Green Pipeline at a location west of Buhler, Louisiana.

4. West Hastings Research MVA Program

Denbury and the Texas Bureau of Economic Geology (BEG) would jointly implement the West Hastings research MVA program aimed at providing: an accurate accounting of approximately 1 million tons of stored CO₂, and a high level of confidence that the CO₂ injected in a portion of West Hastings field during existing EOR operations will remain permanently sequestered.. The West Hastings research MVA program would monitor for possible CO₂ leakage through strata above the target EOR zones, particularly in an aquifer above the main cap rock layer, in shallower aquifers that could serve as underground sources of drinking water, and in soil at the ground surface. The West Hastings research MVA program would also measure and analyze several geophysical parameters in an effort to detect or map CO₂ movement. The West Hastings research MVA activities would supplement Denbury's ongoing commercial monitoring activities and regulatory requirements performed for commercial CO₂ EOR and would provide additional information regarding the movement and confinement of CO₂.

2.3 Project and Technology Descriptions

The following sections describe the components of Leucadia's LCCE Gasification plant and Lake Charles CCS project, including locations and an overview of major equipment and processes.

2.3.1 LCCE Gasification Plant (Connected Action)

LCCE Gasification would convert petroleum coke into syngas to produce methanol, hydrogen gas, and sulfuric acid, as well as CO₂. The LCCE Gasification plant would provide raw syngas containing CO₂ to the Lake Charles CCS project, where the CO₂ would be separated from the syngas. Figure 2.3-1 shows the location of the gasification plant and associated off-site facilities. The facility would be located on an approximately 70-acre parcel of previously undeveloped land leased from the Lake Charles Harbor and Terminal District (Port of Lake Charles). The parcel is located on the west bank of the Calcasieu River, adjacent to Bulk Terminal No. 1, in southern Calcasieu Parish, Louisiana. The area is zoned heavy industrial, and the proposed operations are compliant with this designation. Adjoining and surrounding properties are occupied by the Citgo Refinery, the City of Sulphur's wastewater treatment plant, Halliburton Energy Services, Louisiana Pigment Company, Basell USA, the Port of Lake Charles Bulk

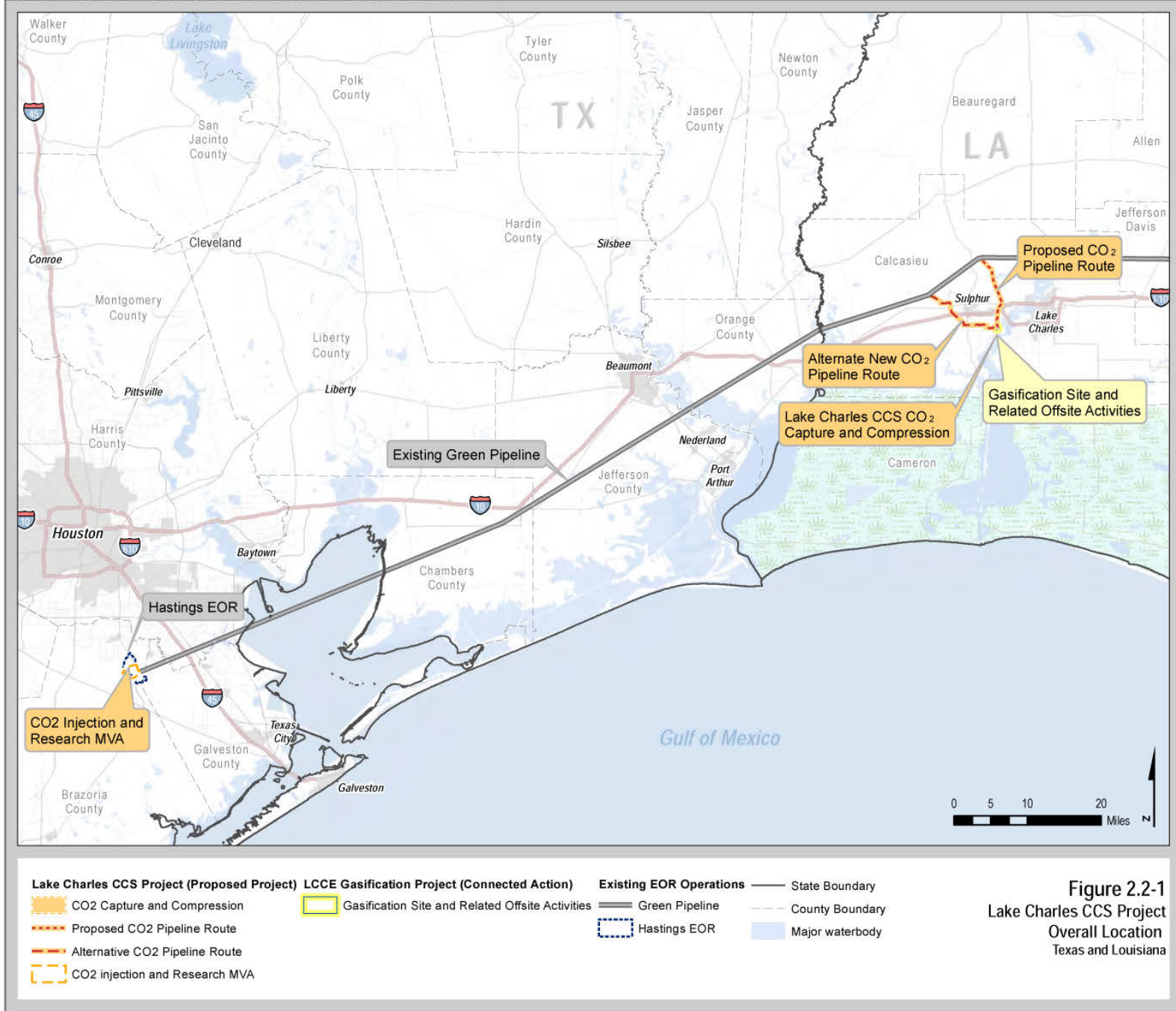
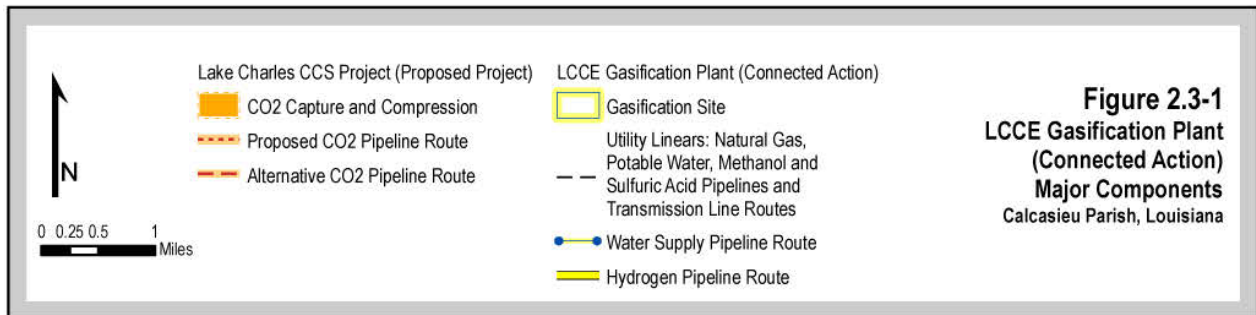
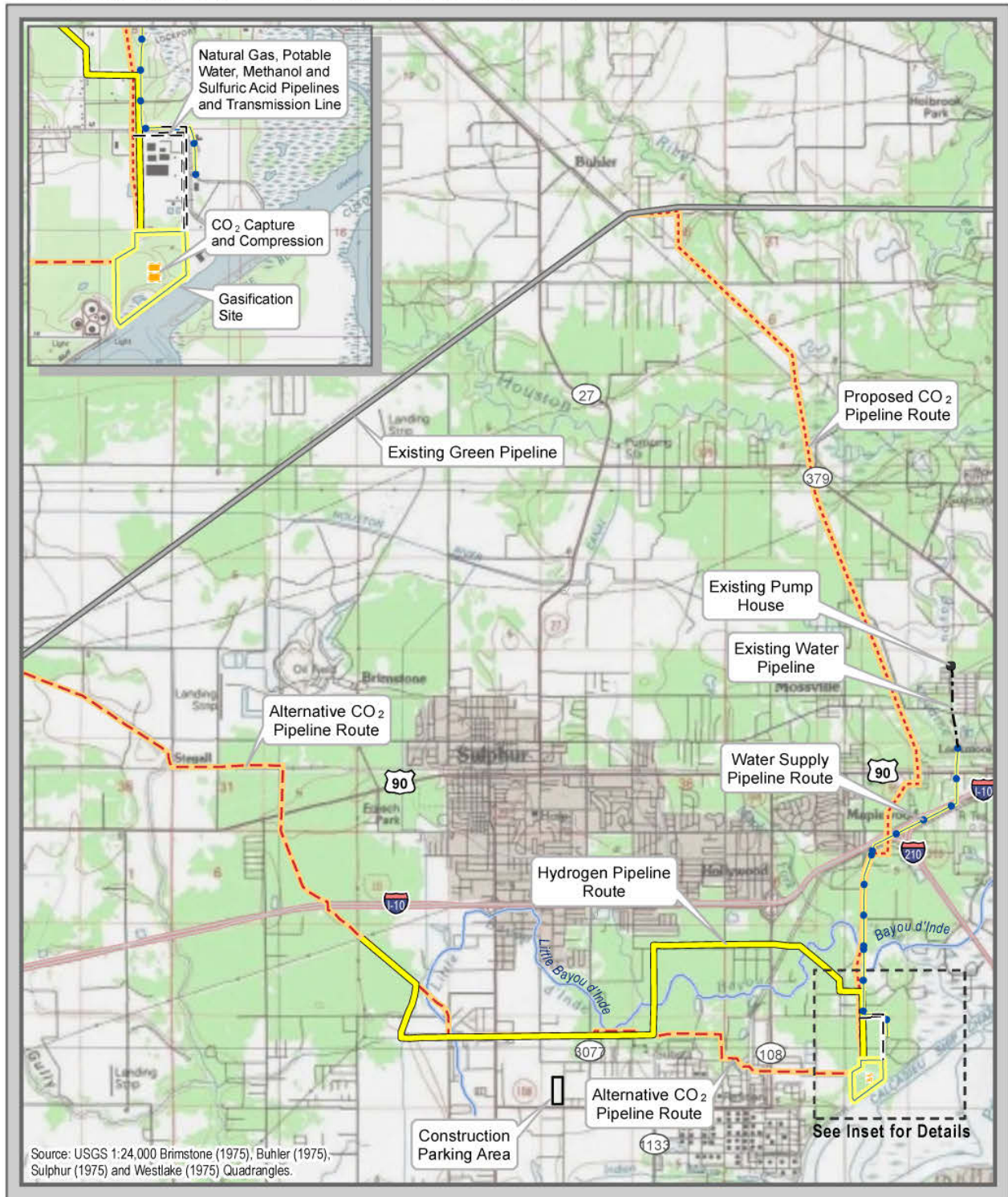

Figure 2.2-1
Lake Charles CCS Project
Overall Location
Texas and Louisiana

This page left blank intentionally.



This page left blank intentionally.

Terminal No. 1, and the Lake Charles Coke Handling Terminal (jointly owned and operated by ConocoPhillips and the CITGO Petroleum Corporation).

Leucadia selected the site based primarily on its access to petroleum coke and available land and proximity to customers for the products of LCCE Gasification (Leucadia 2012a). Leucadia previously obtained many of the necessary environmental permits and approvals for construction and operation of the LCCE Gasification plant; chapter 6 lists the federal and state permits required and received. LCCE Gasification would require new utility linears and pipelines for delivery of materials and transport of products. LCCE Gasification would include pipelines for potable water, natural gas, water supply, methanol, hydrogen gas and sulfuric acid, a transmission line to interconnect with the existing electric transmission system, and off-site storage of methanol and sulfuric acid. Leucadia selected the locations of the project components using siting criteria, including:

- Land ownership (public, private);
- Consistency with current land use;
- Proximity of the Port of Lake Charles to the gasification plant's major components;
- Proximity to the gasification facility for off-site components;
- Parcel size;
- Use of existing utility corridors;
- Avoidance of wetlands, streams, and floodplains;
- Minimization of the number of pipeline and linear stream crossings;
- Avoidance of sensitive habitats; and
- Avoidance of cultural resources.

2.3.1.1 Major System Components

Figure 2.3-2 provides the facility layout and identifies the locations of major components of the gasification process. The sections below describe these major system components.

Petcoke Receiving, Storage, Handling, and Feeding.

Leucadia would purchase approximately 2.6 million tons of petcoke feedstock per year from marketing suppliers that supply, transport, and handle bulk petcoke. The petcoke feedstock purchased by Leucadia would primarily originate from the Gulf Coast region, which produces approximately 58% of the U.S. petcoke supply.

Petroleum coke, or "*petcoke*," is a high-carbon, high-sulfur, solid residue from petroleum refining (cracking) process. Petcoke can be used as fuel for electricity production and for anode production. The majority of petcoke produced in the US is exported.

Leucadia's market suppliers would contract with marine transport companies to deliver petcoke to the existing Port of Lake Charles Dry Bulk Terminal, which is located on 71 acres at the Rose Bluff Cutoff on the Calcasieu Ship Channel, adjacent to the proposed LCCE Gasification plant site. The Dry Bulk Terminal has a 2,200-foot wharf and a 40-foot projected depth at dockside. The facility can accommodate two vessels for simultaneous loading or unloading. Petcoke purchased from suppliers in the Gulf Coast region would be transported to the Dry Bulk Terminal by ocean-going barges and inland barges. Harbor assist tugs would be used to guide the barges in for docking and unloading. Petcoke purchased from local suppliers in Louisiana and Texas could be transported to the Dry Bulk Terminal by railcar and truck.

The Port of Lake Charles would transfer the petcoke from the Dry Bulk Terminal to the LCCE Gasification plant site via an elevated covered conveyor system. Leucadia would store petcoke in feed bins, and conveyors would move the petcoke from the feed bins to the slurry preparation area. The petcoke, water, and fluxant would be mixed together in grinding mills to achieve the desired slurry concentration for the gasifier.

Gasification. Figure 2.3-3 shows the LCCE Gasification process flow diagram (Leucadia 2011a). The LCCE Gasification plant would consist of four GE gasifiers, three operating under normal conditions and one as a spare. During operation, the petcoke slurry and oxygen are injected into the gasifier reaction chamber.

The GE quench gasifier is a two section, refractory-lined vessel that operates at a temperature of approximately 2,500 degrees Fahrenheit (°F) and a pressure of approximately 1,000 psig. In the top section, the gasification zone, the petcoke slurry and oxygen gas react, producing syngas and heat. Oxygen is provided by an air separation unit (ASU) that separates atmospheric air into high purity oxygen gas (O₂), nitrogen gas (N₂), and small amounts of argon gas (Ar). The lower section of the gasifier is the quench chamber. Water quenches, or cools, the raw syngas and solids. The syngas that leaves the quench chamber is cleaned with water in a scrubber column to remove any particulates carried within the syngas from the quench chamber. Syngas enters the bottom of the scrubber vessel, and water enters the top of the scrubber vessel. Particulates are removed as the syngas rises up through the scrubber and comes in contact with the water. A blowdown stream (black water) containing fine slag and unreacted particles (char) is removed continuously from the quench chamber to limit solids accumulation. At the exit of the gasifier, the syngas consists primarily of H₂, CO, steam, and CO₂, with small amounts of N₂ and hydrogen sulfide (H₂S), and trace amounts of methane (CH₄), carbonyl sulfide (COS), and ammonia.

After leaving the scrubber column, the syngas enters the downstream processing for removal of acid gases and production of commercial-grade hydrogen gas and methanol. For the proposed project, a portion of the syngas would be reacted with water vapor over a catalyst, converting or “shifting” the CO to CO₂. The shifted syngas would be cooled, the water vapor would be condensed, and the water would be recycled for use in the gasifiers. Excess heat would be used to generate steam, which would drive steam turbines to produce electric power. The electricity would be used to provide a significant portion of the energy needs for operations.

The wastewater from the quench chamber would be treated to remove solids, and most of it would be recycled to the quench chamber along with condensed water from syngas scrubbing (Leucadia 2011b).

The syngas enters two Lurgi Rectisol® Acid Gas Removal units (AGRs) which would remove acid gases (H₂S, COS, and CO₂) from the syngas. The AGRs are part of the Lake Charles CCS project and are described in Section 2.3.2.1.

Methanol Production. The purified syngas from the AGRs would be fed into a methanol synthesis process, where H₂ and CO would react over a copper-based catalyst bed to produce AA-grade methanol. The impurities in the gas would be purged from the system to prevent the build-up of gases such as N₂, Ar, and CH₄. The purged gas stream would be used as fuel gas for LCCE Gasification (Leucadia 2011c).

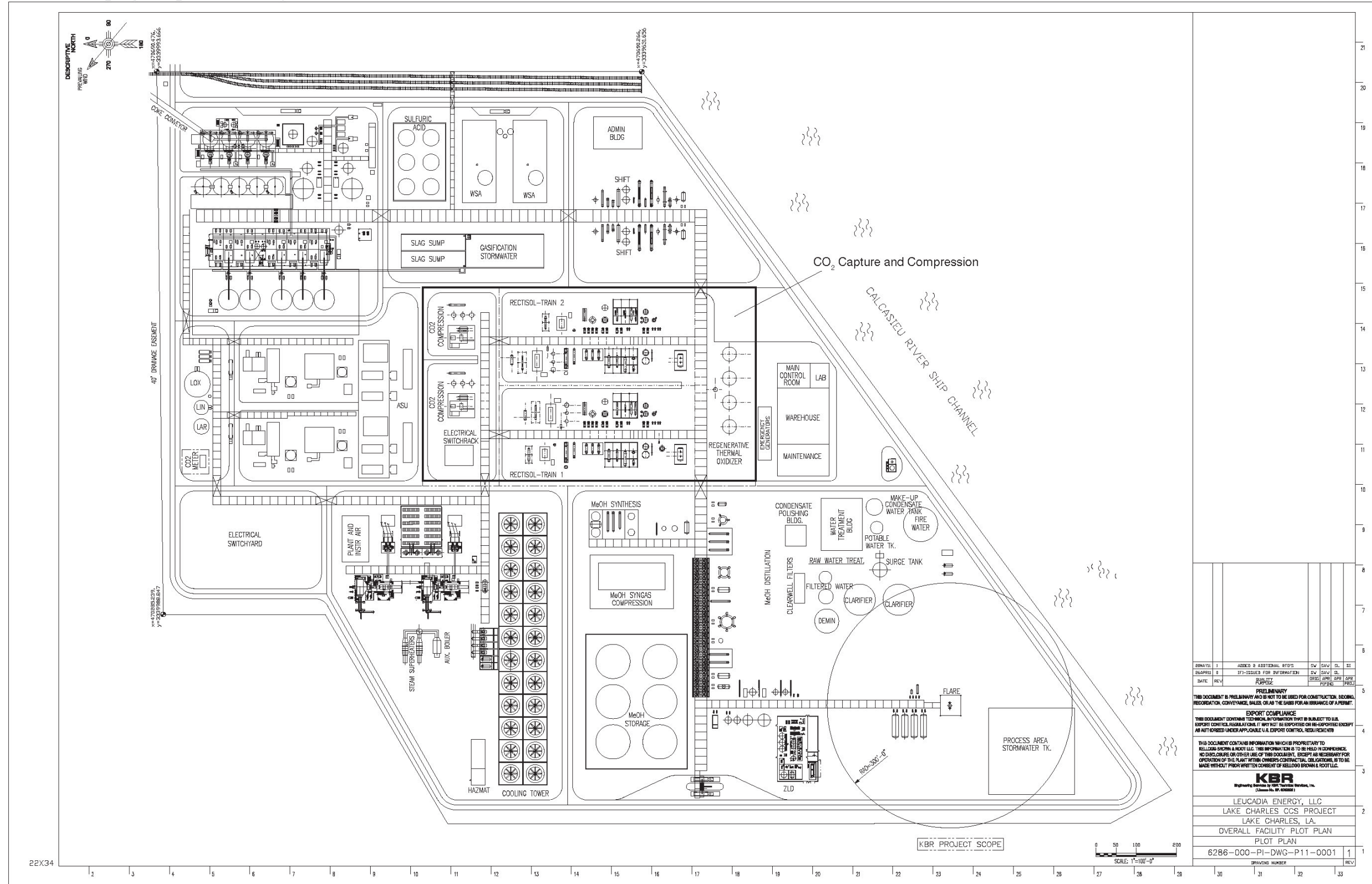

Figure 2.3-2
LCCE Gasification Plant Layout
 Calcasieu Parish, Louisiana

This page left blank intentionally.

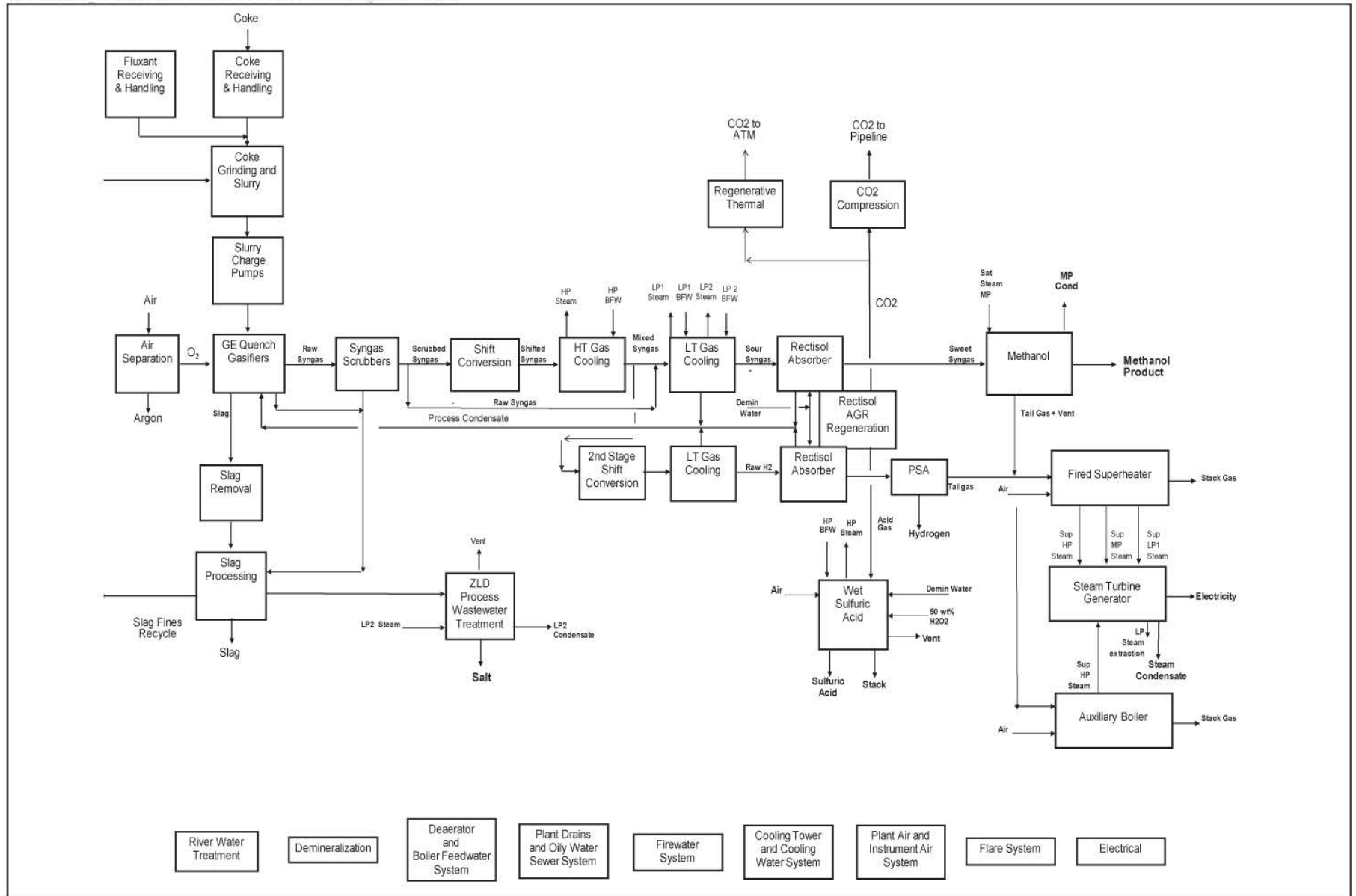

Figure 2.3-3
LCCE Gasification Process Flow Diagram

Hydrogen Gas Production. A portion of the purified syngas from the AGRs (after H₂S and CO₂ removal) would be fed to a pressure swing absorption (PSA) unit, where hydrogen gas would be separated out and purified (Leucadia 2012a). The purified hydrogen gas would be sent to the H₂ compression unit to meet the pipeline pressure requirement. The waste gases, or tail gas, would be burned as fuel (Leucadia 2011c).

Power Generation. Power would be produced primarily from excess heat and the combustion of waste gases. Excess heat would be recovered to produce electrical power, thereby reducing overall requirements for power. Heat energy would be recovered through a variety of exchangers that produce low, medium, and high pressure steam. Combustion of off-gases in the superheater would ensure proper steam conditions for the steam turbine (the auxiliary boiler also uses off-gases). The steam would expand, causing turbine blades to turn a shaft coupled to an electric generator. The LCCE Gasification plant would produce between 165 MW and 180 MW of power at design capacity for use throughout the plant, including the Lake Charles CCS project.

Methanol Storage, Handling, and Transport. Purified methanol would be transported to the off-site methanol and sulfuric acid storage area via a new 8-inch outside diameter (O.D.) pipeline installed in an existing right-of-way (ROW). Purified methanol would be transported by pipeline from the storage tanks to carrier vessels that would dock along the Calcasieu River at the Port of Lake Charles via a new 12-inch pipeline installed within an existing ROW.

The methanol storage area would be located a short distance from the LCCE Gasification plant site on the Port of Lake Charles. Leucadia is in the process of identifying a parcel of up to 40 acres required for storage. Leucadia would use the siting criteria described in Section 2.3.1 above to select the proposed site within 1 mile to minimize the methanol pipeline routes to and from the storage area.

Sulfur Recovery, Storage, Handling and Transport. The sulfide components of the acid gases from the AGR would be sent to a Haldor Topsoe wet sulfuric acid (WSA) unit. Haldor Topsoe's WSA process uses a catalyst to recover sulfur from hydrogen sulfide and other sulfur compounds as concentrated, commercial-grade sulfuric acid. The WSA process also produces steam, which can be used to produce electric power for operations. Sulfuric acid would be stored on-site adjacent to the WSA unit. Sulfuric acid would be transported to offsite storage tanks located at the methanol and sulfuric acid storage area via a new 8-inch pipeline installed in an existing ROW. Sulfuric acid would also be transported via pipeline from the offsite storage area to the Port of Lake Charles via a new 8-inch pipeline adjacent to the methanol pipeline and within an existing ROW.

Hydrogen Gas Pipeline. The proposed pipeline would transport hydrogen gas of 99% purity from LCCE Gasification via a new 8- or 12-inch pipeline approximately 8.5 miles long, with a maximum allowable operating pressure of 1,000 psig. Figure 2.3-1 shows the proposed hydrogen gas pipeline route. The pipeline route would cross six waterbodies, including Bayou d'Inde, and connect to an existing Air Products hydrogen pipeline. Approximately 99% of the hydrogen gas pipeline route follows existing ROWs (e.g., roadways, pipelines, railroads, transmission lines, and other linear features) and would use a 75-foot-wide temporary construction ROW and a 50-foot-wide permanent ROW.

The hydrogen pipeline would begin at an interconnection with an existing Air Products hydrogen pipeline in an existing utility ROW located south of Interstate 10, southwest of Sulphur, Louisiana. From the interconnection, the hydrogen pipeline would travel southeast in an existing utility corridor that intersects the Sabine River Authority freshwater diversion canal. The pipeline would continue south in an existing utility ROW, parallel to the right descending bank of the diversion canal and would then cross under Currie Drive. The pipeline would then continue southeast in an existing utility ROW and then turn due east and travel in an existing utility ROW, parallel to the right descending bank of the diversion canal and cross under Carlyss Drive. The pipeline would continue due east in the existing utility ROW and then would cross under Ruth Street. After crossing Ruth Street, the pipeline would continue to travel due east in an existing utility ROW and then would cross South Arizona Street, continuing due east and then turning due north, crossing the freshwater diversion canal. After crossing the canal, the pipeline would continue due north in an existing utility ROW, cross under Bayou d'Inde and continue north in an existing utility ROW. The pipeline would cross underneath Swisco Road and then would turn due east and travel parallel to the north side of Swisco Road, cross State Hwy 108 and then travel due east a short distance before crossing underneath two Union Pacific railroad tracks and then crossing Bayou d'Inde again. After crossing Bayou D'Inde, the pipeline would travel southeast in an existing utility corridor for approximately 0.5 miles, cross Bayou d'Inde Pass and continue south where the pipeline would enter an existing utility ROW and would terminate at the LCCE Gasification plant site.

Water Supply Pipeline. Leucadia would obtain water from the Sabine River Authority (SRA) via the Sabine River Diversion Canal. Leucadia would connect to the existing 20-inch raw water supply pipeline at Bayou Viridine and construct a new 4-mile-long, 8-inch pipeline from the tie-in point south to the LCCE Gasification plant. Figure 2.3-1 shows the proposed water supply pipeline route. The proposed route crosses one major waterbody, Bayou d'Inde. The pipeline would use a 50-foot-wide temporary construction ROW and a 50-foot-wide permanent ROW. Approximately 76% of the water supply pipeline route follows existing ROWs.

From the tie-in at the existing pump house, the pipeline would travel south in an existing utility ROW, crossing under three railroad tracks and U.S. Hwy 90. The pipeline would continue south in an existing utility ROW and cross under Interstate 10 and enter an existing utility ROW that runs parallel to Interstate 10. The pipeline would then travel southwest for approximately 1 mile and then would then enter an existing utility ROW and travel south, and would cross underneath Bayou d'Inde and then continue south across Bayou d'Inde Road and terminate at the LCCE Gasification plant site.

Natural Gas Pipeline. Leucadia would obtain natural gas from Centerpoint Energy via a new pipeline, approximately 0.5 mile-long and 8-inches in diameter, which would connect to Centerpoint Energy's existing pipeline at Bayou D'Inde Road. Figure 2.3-1 shows the natural gas pipeline route. The new natural gas pipeline would have a maximum operating pressure of 250 psig and would be constructed in the existing ROW on the south side of Bayou D'Inde Road, just north of the project site. The pipeline would then continue east on the south side of Bayou D'Inde Road within a presently maintained ROW, which contains rail, electric, oxygen gas, and nitrogen gas lines. At the eastern end of Bayou D'Inde Road, the natural gas line would cross under the Port of Lake Charles service road and the Union Pacific rail spur. It would then continue south within an existing ROW on the east side of the Port of Lake Charles service road

until reaching the Port of Lake Charles Bulk Handling Terminal. The proposed pipeline route involves no waterbody crossings.

Transmission Line. Leucadia would connect the LCCE Gasification plant to the Bayou d'Inde electrical substation located on Bayou d'Inde Road via a new approximately 0.5 mile electrical transmission line. The transmission line would be installed west of the LA Pigment facility in an existing ROW. Alternatively, Leucadia may install the transmission line east of the LA Pigment facility.

2.3.2 Lake Charles CCS Project

The Lake Charles CCS project would consist of the CO₂ capture and compression equipment, the CO₂ connector pipeline, and the West Hastings research MVA program. Leucadia would capture and compress CO₂ for sale to Denbury. The CO₂ would be transported through the 11.9-mile-long pipeline that a Denbury affiliate would construct, own, and operate. The CO₂ would be combined with CO₂ from other anthropogenic sources and from natural sources and delivered to EOR fields connected to the Green Pipeline, including the West Hastings oil field. Denbury would inject the CO₂ from the pipeline into the West Hastings oil field and conduct the research MVA on a portion of the West Hastings oil field representing the use of about 1 million tons of CO₂ per year in ongoing commercial EOR operations. Each component of the project is described separately below.

2.3.2.1 CO₂ Capture and Compression

The Lake Charles CCS project CO₂ capture and compression equipment would be located within the LCCE Gasification plant. The main components of the CO₂ capture and compression equipment would include AGRs, CO₂ compressors and enclosures, a custody transfer station, and ancillary equipment.

Major System Components

Acid Gas Removal Units. The Lake Charles CCS project would use two Lurgi Rectisol® AGRs to remove impurities from the syngas produced by the LCCE Gasification plant. The AGRs would use chilled liquid methanol (-70 degrees F) as a gas-washing solvent to remove hydrogen sulfide (H₂S), carbonyl sulfide (COS), CO₂, and trace impurities that are by-products of syngas production. The AGRs would produce CO₂ in the purity needed for sequestration or EOR (Lurgi 2010).

The AGR produces a high quality CO₂ gas stream of approximately 99 % purity, 0.67 % CO, and 0.32 % H₂, and 0.01% other trace constituents.

As shown in Figure 2.3-4, a portion of syngas stream would be directed to each of the two AGRs (Leucadia 2012d). Each of the two AGRs consists of a two-stage absorption process. In the first stage of the absorber, sulfur compounds are absorbed from the syngas into the methanol solvent. The methanol will be maintained at -70 degrees F using a propylene refrigerant compressor on each of the AGRs. The H₂S “rich” solvent exits the bottom of the absorbers and is sent to the H₂S stripping process. In the second stage of the absorption process, the CO₂ from the syngas is absorbed into the methanol solution. The clean syngas is sent to the methanol synthesis reactor. The CO₂ rich methanol solvent exits the bottom and is sent to the CO₂ Flash column. The CO₂ would be flash stripped from the methanol by pressure letdowns at three different levels. These

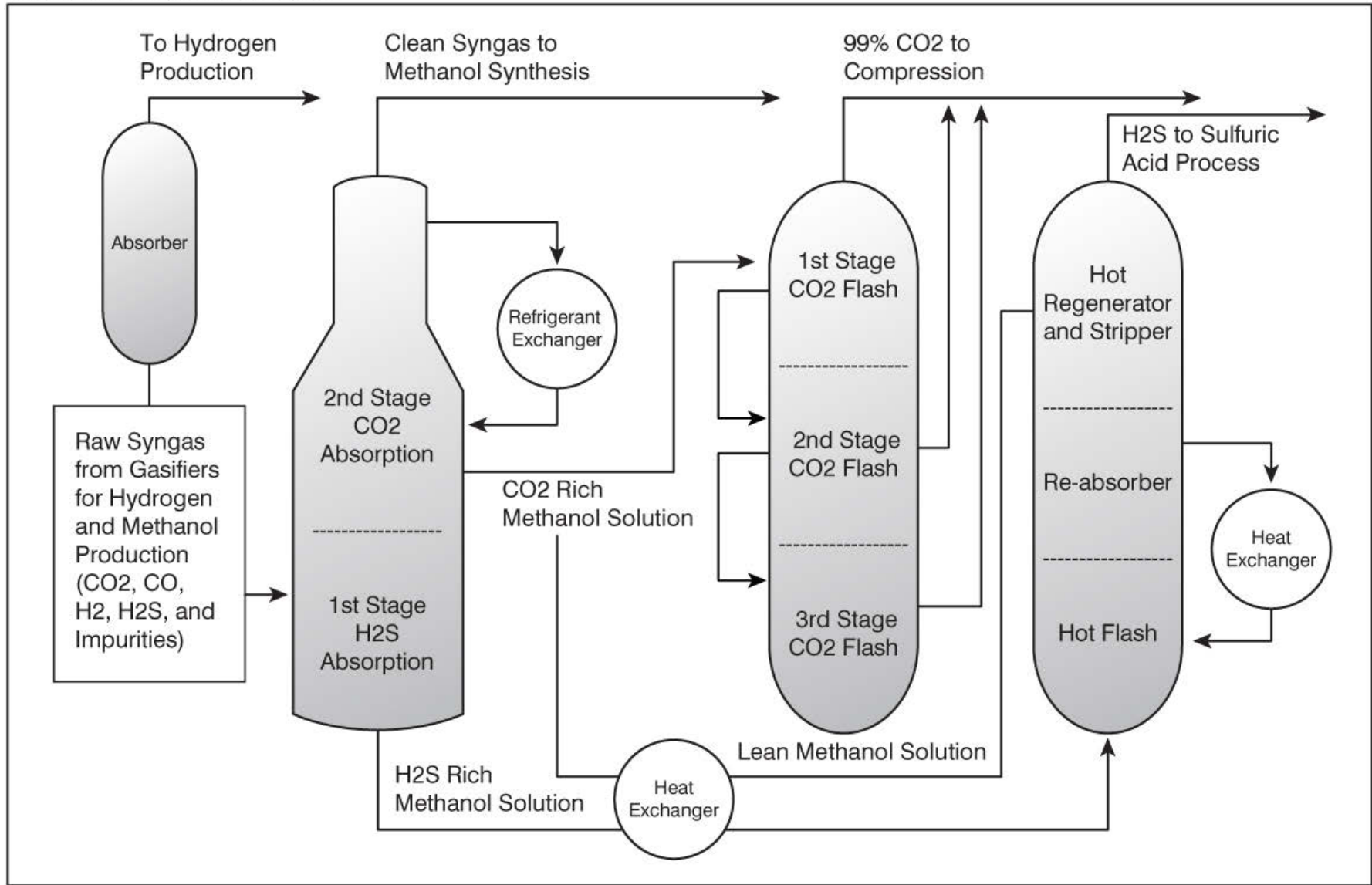

Figure 2.3-4
Lurgi Rectisol® Acid Gas Removal System

three 99% pure CO₂ streams would be routed to the CO₂ compressor (Leucadia 2011d). The H₂S is removed from the H₂S rich methanol in the hot regenerator and stripper column. The 45% H₂S gas from the stripper is sent to the WSA process for conversion to sulfuric acid. The methanol from the H₂S stripping process is recycled to the absorber columns.

CO₂ Compressors. Leucadia would install two CO₂ gas compressors in parallel, one for each AGR unit. The compressors would compress the three CO₂ gas streams from the AGRs to a pressure of approximately 2,250 psig for transport in a supercritical state, meaning the CO₂ gas has flow properties like a liquid. The selected compressors are multi-stage integral-gear centrifugal compressors driven by synchronous, fixed-speed electric motors and equipped with interstage cooling (using water), which would be chosen for this application because they are known to be reliable and efficient (Leucadia 2011d).

The supercritical liquid phase of CO₂ occurs at pressures greater than 72.9 atmospheres (1071.3 psi) and temperatures of greater than 88 °F (31.1 °C)

Custody Transfer Station. Leucadia would install a Custody Transfer Station within the LCCE Gasification site for transfer of the CO₂ to the CO₂ pipeline at the boundary of the LCCE Gasification. The custody transfer station would include two (each 100% redundant) orifice meters with associated instrumentation for producing custody-transfer requirements of the metered CO₂ from Leucadia to Denbury.

Ancillary Equipment. The unit-specific ancillary equipment and systems needed to support the CO₂ capture and compression facilities include electrical system switchgear to supply the AGRs and CO₂ compressors, load-commutated inverters for starting the compressors, a chilled water supply system, and two regenerative thermal oxidizers to allow venting of CO₂ when required (Leucadia 2012a).

2.3.2.2 CO₂ Pipeline

Figure 2.3-5 shows the proposed pipeline route (preferred route) and two alternative routes. Beginning at the LCCE Gasification plant, the proposed pipeline route would travel north in an existing utility ROW and would cross Bayou D'Inde Road and Bayou D'Inde and then continue north in an existing utility ROW running parallel to Bayou D'Inde Pass Road. The pipeline would continue northeast and cross underneath several roadways and Interstate 10 and then turn north in an existing utility ROW. The pipeline route would cross underneath U.S. Hwy 90 then travel parallel to existing rail lines in an existing ROW. The route would continue northwest and then cross underneath rail lines, High Hope Road and Bankens Road and terminate at an interconnect with the existing Green Pipeline (CH2M Hill 2011a).

Denbury sited the pipeline corridor to maximize the use of existing utility ROWs to the extent practicable and in accordance with applicable federal regulations. These regulations include 49 CFR 195, *Transportation of Hazardous Liquids by Pipeline*, which requires avoiding, to the extent practicable, areas containing private dwellings, industrial buildings, and places of public assembly. The pipeline would be located entirely within Calcasieu Parish and would require a temporary 95-foot corridor during construction that would parallel existing rights-of-way (ROWs) (transmission lines, roads, pipelines, railroads, and other linear features) to the extent practicable. Denbury would maintain a permanent 50-foot right-of-way (ROW) for operation of the pipeline. Additional temporary work space at road crossings, wetland and waterbody crossings, and at truck turnaround areas would also be required during construction. Denbury

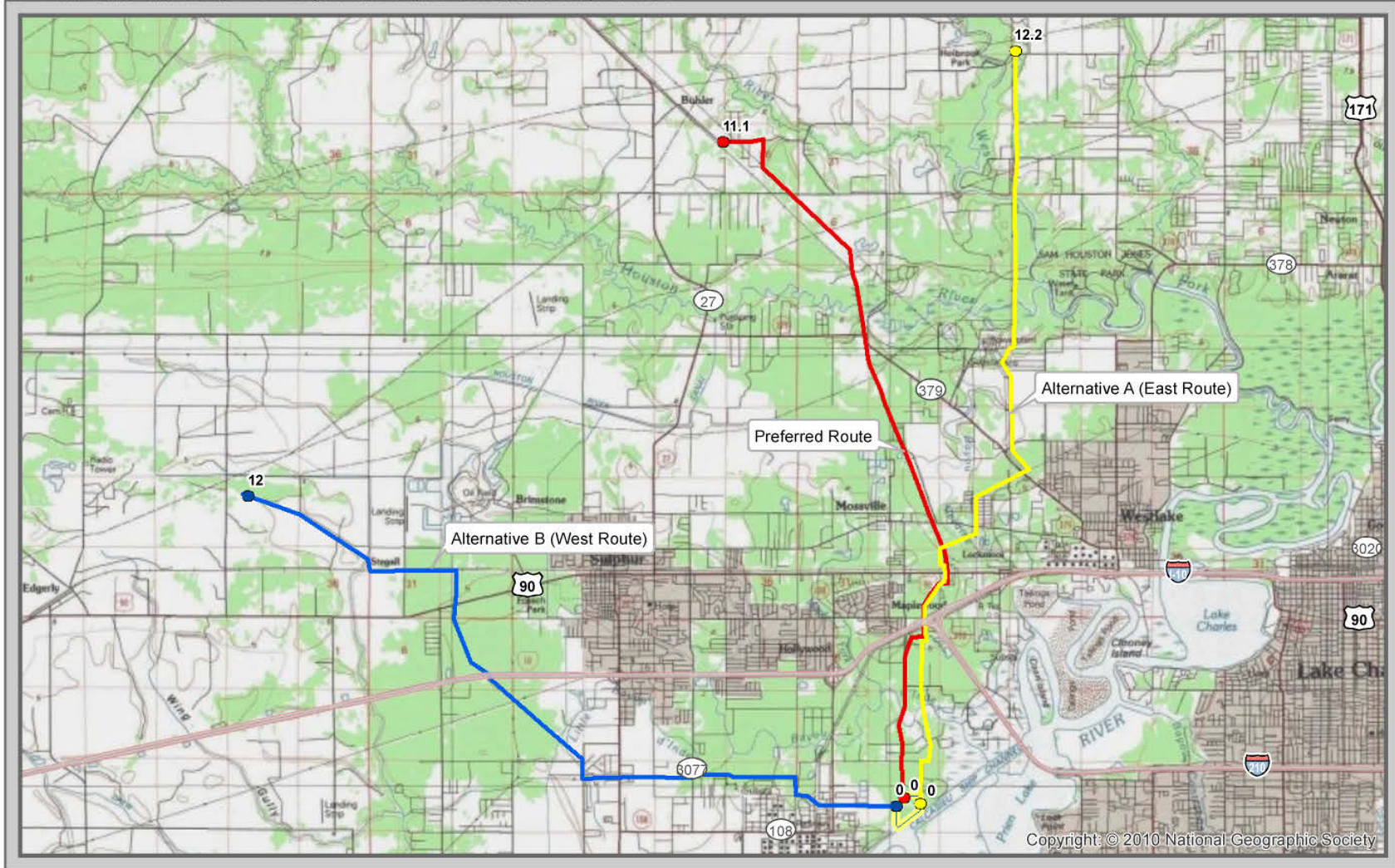

Copyright: © 2010 National Geographic Society

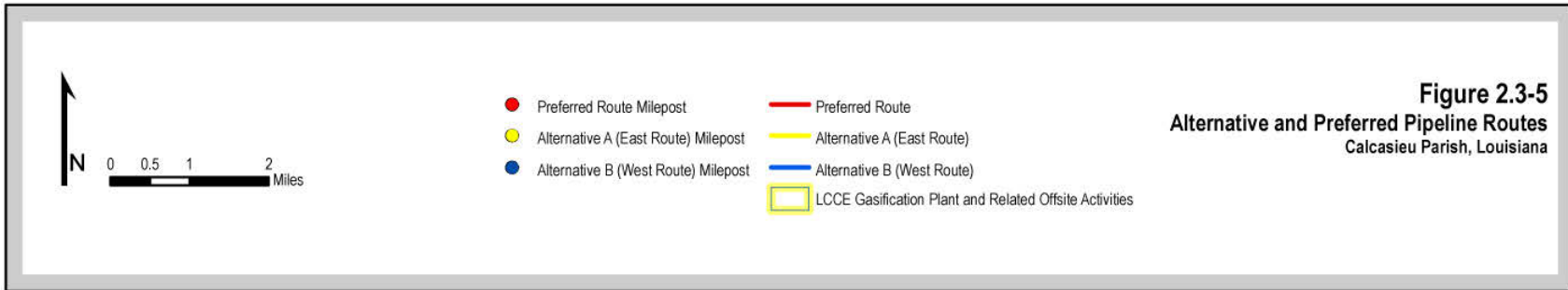

Figure 2.3-5
Alternative and Preferred Pipeline Routes
 Calcasieu Parish, Louisiana

This page left blank intentionally.

would utilize an upland open field near the Lake Charles Gasification Facility on the north side of Bayou D'Inde road as a pipe yard and would use an existing upland industrial storage yard located on U.S. Highway 90 and Walcot Road as a warehouse yard during construction of the CO₂ pipeline.

The main components of the proposed pipeline would include pipeline materials, controls, and monitoring systems. The pipeline would be constructed of carbon steel and approximately 16 inches in diameter. The pipeline would operate at pressures up to 2,360 psig. As currently designed, Denbury would bury all segments of the pipeline at a minimum of 36 inches below the ground surface or at greater depths based on site conditions and to minimize the possibility of damage to the pipeline. Segments under inland water bodies wider than 100 feet would be buried a minimum of 60 inches below the underwater natural bottom of the water body. Segments under drainage ditches, public roads, or railroads would be buried a minimum of 60 inches below the roadbed. Denbury may also use thicker walled pipe as well as timber or concrete mats to protect segments of the pipeline at road, railroad, water body, and foreign pipeline crossings. Cathodic protection would include an industry-standard application of a low voltage charge to the pipeline to counter the positive ions created by the corrosion process.

The pipeline would be installed below ground. Visible features along the route would be: (1) pipeline location markers (primarily positioned at road and stream crossings, fence lines, or in areas where the pipeline would be above the ground surface); (2) cathodic protection test posts located on each side of all road crossings and at waterbody crossings with main line valves; and (3) aboveground facilities (i.e., valves, launchers/receivers, and meter stations). Location posts, cathodic protection, and facilities would be located within the maintained ROW. Location posts would be approximately 4.5-foot tall and display the mileage as well as a cautionary statement such as, "In case of emergency or before digging, call (owner's name and telephone number)."

Denbury would install mainline isolation valves on both sides of each major water body crossing, including the Bayou d'Inde, the Sabine River Canal, and the Houston River (CH2MHill 2011a). These valves, along with pipeline pressure monitoring equipment, would be monitored at all times during pipeline operation.

Denbury would construct, own, and operate a meter station at the tie-in to the existing Green Pipeline. The meter station would require an approximately 75-foot by 50-foot permanent site, which would be located inside an existing Denbury facility at mile point 11.00.

2.3.2.3 West Hastings Research MVA Program

The West Hastings oil field is located between Alvin and Pearland, Texas, near State Highway 35, south of Houston. It underlies approximately 25 square miles of farmlands, suburban areas, and residential neighborhoods. The research MVA program would be limited to a parcel of approximately 2.8 square miles of the oil field.

Denbury and the BEG would implement a research MVA program to supplement regulatory requirements and commercial monitoring activities performed for Denbury's ongoing commercial EOR activities. This section describes the CO₂ sequestration in a portion of the West Hastings oil field through existing EOR operations.

CO₂ EOR presents an opportunity to store significant volumes of CO₂ from an industrial source that otherwise would be emitted to the atmosphere with the additional benefit that oil reservoirs would yield oil that otherwise would be difficult to obtain. From the beginning of CO₂ flooding in the early 1970s, the U.S. has been in the lead of technology and investment in the use of CO₂ for EOR. This established expertise and the existing regulatory framework for the injection of CO₂ in commercial EOR operations provide an opportunity for demonstrating long-term geologic sequestration. The United States Environmental Protection Agency (EPA) reports that EOR was used in 80 oil fields in the U.S. in 2008, including 45 sites in Texas (EPA 2010 *GTSD*). Currently, the majority of CO₂ injected for EOR is naturally occurring CO₂ obtained from geologic formations.

The U.S. oil and gas industry has more than 35 years of continuous experience in transporting and injecting CO₂ for enhanced oil recovery (EOR).

Figure 2.3-6 illustrates the typical CO₂ EOR components and process. A CO₂ injection well may be installed by drilling a new well or, as more commonly occurs in existing oil fields, by converting an existing oil production well or a water injection well to a CO₂ injection well. Before being used for CO₂ injection, a well undergoes evaluation, including examination of the condition of cement casings and mechanical integrity testing, and additional corrosion protection is added, if necessary. CO₂ is injected through a number of wells into the target reservoir, where the CO₂ then flows through the permeable space of the reservoir mixing with the oil to reduce its viscosity (resistance to flow) and causing the oil to swell slightly. The injected CO₂ also creates a pressure drive pushing fluids from the injector wells toward the production wells, where a mixture of oil, water, natural gas, and CO₂ is extracted. At the ground surface, these components are separated. The separated CO₂ stream is dehydrated, recompressed, and recycled into the target reservoir in a continuous process. With each cycle of CO₂ use, a portion becomes permanently trapped in the reservoir, such that it will not move further. At the end of the cycling, CO₂ remains in the reservoir in place of the recovered oil and natural gas. Produced wastewater is separated, processed, and re-injected in a water disposal well, often in the same reservoir (EPRI 1999).

The Stanolind Oil and Gas Company (later to become Amoco) first discovered oil at the Hastings oil field on December 23, 1934 (TSHA 2011b). Oil reserves are recovered from sands in the Oligocene-age Marginlina, Frio, and Vicksburg formations, ranging in depths from 5,000 to 10,000 feet below ground surface (bgs). In 1953, the Stanolind Oil and Gas Company drilled the deepest known well at the Hastings oil field to a depth of 13,024 feet bgs. Collectively, the Frio Deep-Seated Salt Dome fields are significant because their cumulative yields exceed those of any other producing formation in southeastern Texas. By 1982 the fields reported a combined cumulative production in excess of 2.3 billion barrels of oil, and at the end of 1993 the figure surpassed 2.4 billion barrels (TSHA 2011a). Denbury purchased an interest in the Hastings oil field in 2009.

As part of its commercial operations, Denbury constructed new facilities and drilled wells or reworked existing wells in the West Hastings oil field for injection of CO₂ for EOR, production of oil and gas, testing, water production, and brine disposal. Denbury commenced CO₂ injections in Block A of West Hastings oil field on December 16, 2010 (APCI, 2011). This CO₂ injection process, which is referred to as a “tertiary” or enhanced EOR (previous water floods were the secondary process of oil production after the primary production from simple pumping

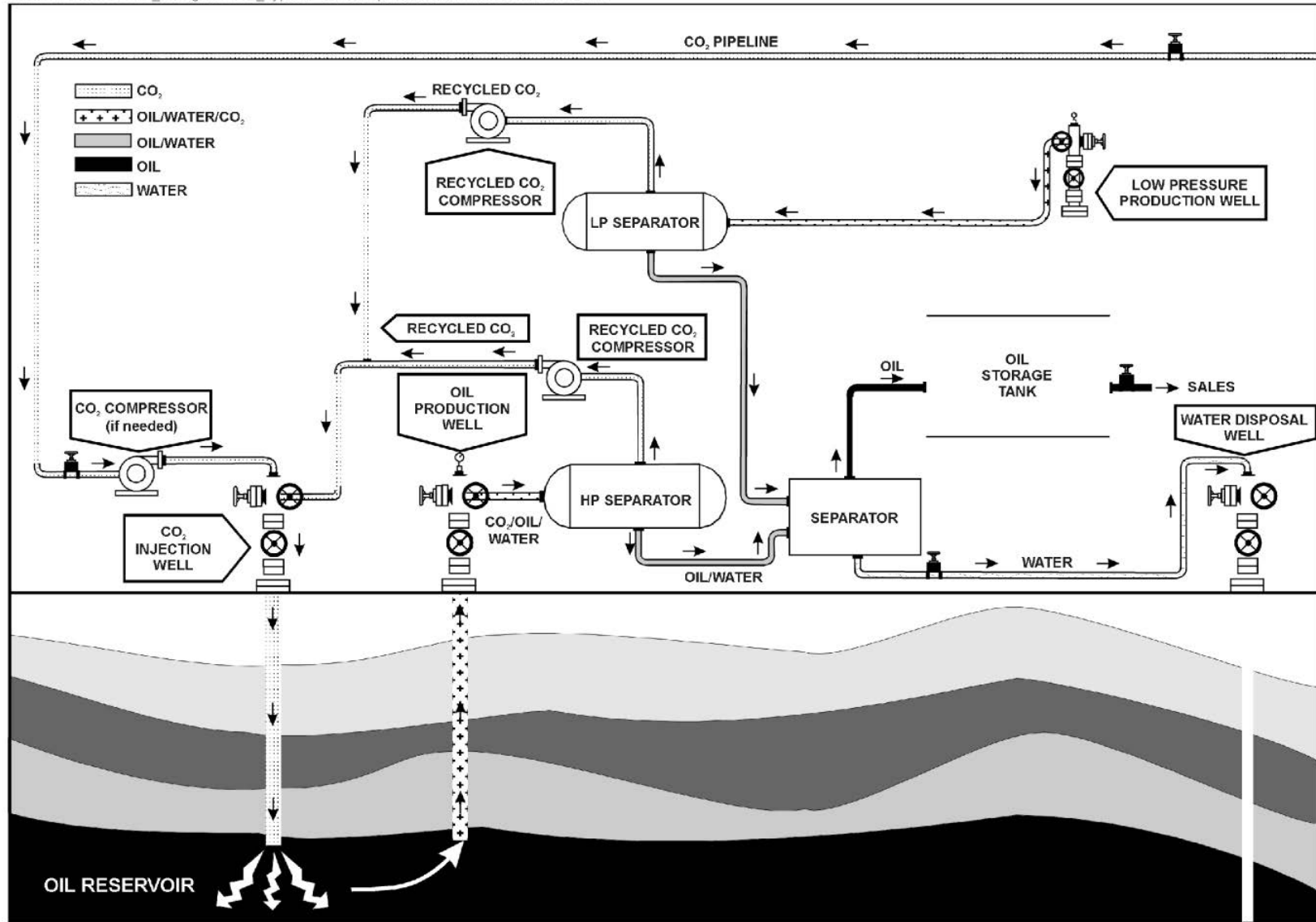

Source: Advanced Resources International (Modified from Getz, 1998)

Figure 2.3-6
Typical EOR Components and Process

had declined to non-economical levels), requires large volumes of CO₂. Denbury anticipates CO₂-based EOR will yield almost as much oil from a field considered to be depleted as was produced in each of the two preceding phases (primary oil production and water-flood EOR), estimating that the entire West Hastings oil field has between 60 and 90 million barrels of potential CO₂ recoverable oil (APIC 2011). The overall preliminary commercial development plan for the West Hastings oil field, including sites for CO₂ injection wells, oil production wells, and site utilities is shown in Figure 2.3-7. As the oil field is developed for commercial EOR, Denbury’s ongoing EOR activities will include the reworking of existing wells and construction of new facilities as needed. Denbury currently injects, on average, 0.52 to 0.64 metric tons of CO₂ for every barrel of oil recovered (Denbury 2011b). During Denbury’s operation, a de minimis amount of the CO₂ processed is emitted to the atmosphere, including CO₂ from EOR operations and CO₂ generated by combustion equipment (Denbury 2011c).

Denbury holds a Class II Non-Hazardous area permit for CO₂ injection in the West Hastings oil field from the Texas Railroad Commission (RRC), as authorized under the federal Underground Injection Control (UIC) Program. As the West Hastings oil field is further developed for EOR, new CO₂ injection wells would be authorized under the existing area permit or through a new permit issued under existing Class II requirements. As indicated in Table 2.3-1, applicants for Class II injection wells must address a variety of technical, geological, and hydrogeological requirements and standards for protection of underground sources of drinking water and the environment. The application requires a determination of the deepest depth of useable water, or underground source of drinking water (USDW) and includes a requirement to set casing through the USDW and cement back to the surface for the protection of the fresh water. In addition to specific well construction requirements to improve well integrity during operation and injection of CO₂ to the target formation, applicants must make best efforts to identify all wells within a 0.25-mile radius of the proposed injection well and provide evidence that all abandoned wells intersecting the injection formation have been properly plugged. The application also requires submission of a log of the intended injection well (or if a new well is proposed, the log from a nearby well) to provide reservoir characteristics to the RRC. The application must include the construction completion information of the intended well, including casing, liner, cement squeeze, tubing, packer, etc. Once a well has been drilled, it is subject to required periodic mechanical integrity testing to look for leaks through the annular space (i.e., space between well casing and tubing that conveys the injected CO₂). During operation of the well, injection pressures are maintained below the formation fracture pressure to avoid the initiation of new hydraulically-induced fractures.

Regulatory requirements for monitoring Class II wells during operation focus on injection pressure and volumes. Denbury’s EOR program includes Class II permit-required monitoring. Denbury’s commercial practices are further described below.

Table 2.3-1 Major Components of a Typical Class II Well Application

Area of Review Methods	Corrective Action Plan and Well Data
Maps of Well/Area of Review	Name and Depth of USDW
Geological Data on Injection and Confining Zones	Operating Data
Construction Procedures	Construction Details
Necessary Resources	Plugging and Abandonment Plan

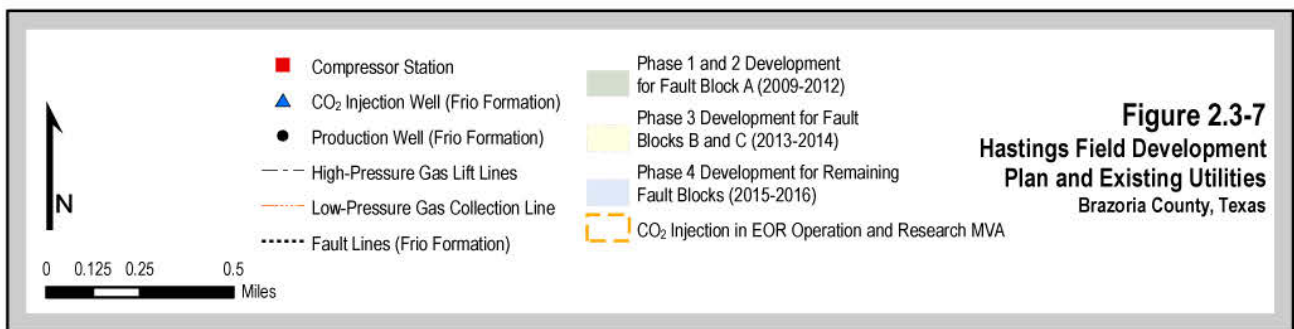
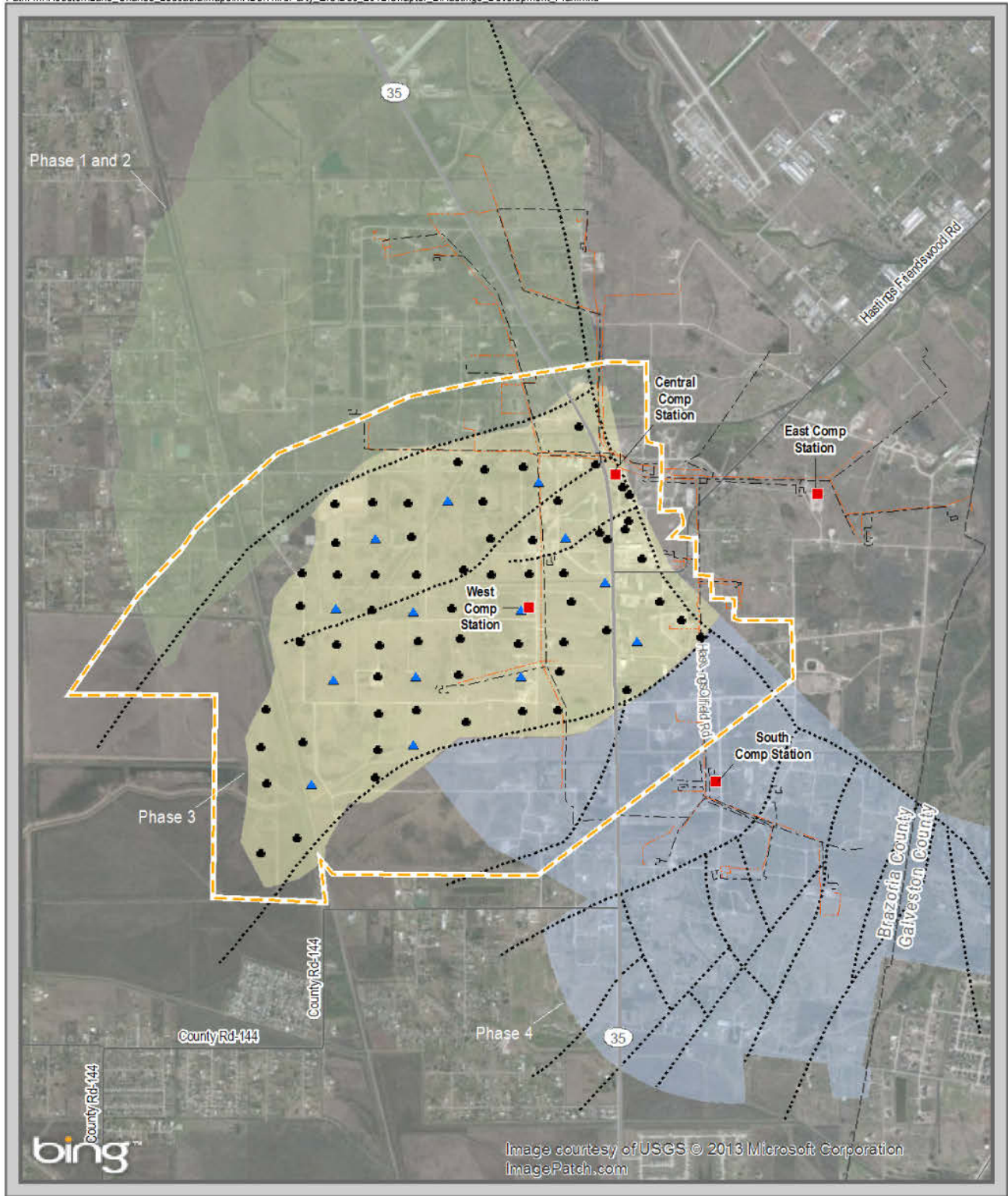

Figure 2.3-7
Hastings Field Development
Plan and Existing Utilities
 Brazoria County, Texas

This page left blank intentionally.

Denbury and BEG would develop and implement the West Hastings research MVA program to test, monitor, and measure the effectiveness of CO₂ sequestration in an ongoing commercial EOR operation. The proposed West Hastings research MVA program would independently test the performance of the CO₂ injection wells and the geologic containment capacity of Blocks B and C within the West Hastings oil field. The purpose of the research MVA program would be to provide an accurate accounting of approximately 1 million tons of stored CO₂ and a high level of confidence that the CO₂ will remain permanently sequestered. Fault Blocks B and C were chosen because they are relatively unaffected by past or current CO₂ EOR or sequestration activities. Denbury's commercial monitoring activities and the West Hastings research MVA program jointly would demonstrate through various techniques for well integrity, flood conformance, above zone monitoring, and fault monitoring that nearly all of the CO₂ injected for EOR is contained in the designated geologic reservoir.

Table 2.3-2 summarizes the specific components of the West Hastings research MVA program, as well as Denbury's existing monitoring activities for its ongoing commercial EOR operations. The major components of the West Hastings research MVA program are well integrity testing, fault monitoring, above-zone monitoring, CO₂ flood conformance testing, and soil gas monitoring. The well-integrity activities of the West Hastings research MVA program would include additional logging of idle wells for parameters such as temperature, noise, and cement bond and would employ techniques such as: ultrasonic imaging (to verify adequate performance), soil gas monitoring below the active soil zone, and groundwater monitoring in existing freshwater wells (APCI 2011). To further look for CO₂ leaks from existing wells, Denbury would partially plug and re-perforate selected wells for monitoring in a permeable zone above the CO₂ injection zones, use selected idle wells for supplemental logging and testing, and allow access to specific previously disturbed surface locations in the West Hastings oil field for drilling and testing of shallow groundwater wells and soil-gas monitoring holes (Steve Walden Consulting and RDB Environmental Consulting 2010a).

Normal commercial monitoring activities for CO₂ EOR consist of reservoir surveillance monitoring of the injected CO₂, referred to as flood conformance. This is accomplished using injection rate and pressure data, production rate and pressure, injection profile logging, and production profile logging. The surveillance data is analyzed, reviewed and, in many cases, incorporated into the numerical models used to interpret and predict CO₂ EOR performance, i.e., the effectiveness of oil production and CO₂ cycling. The West Hastings research MVA program, however, would employ several additional techniques to observe or infer the movement of CO₂ in the subsurface formations during the flood operation. These techniques would include annual vertical seismic profiling (VSP) surveys of the project site; surface and borehole gravity monitoring; real-time bottom hole pressure measurements, and additional or different reservoir modeling to interpret CO₂ migration (APCI 2011).

In addition, the West Hastings research MVA program would measure the fluid pressure profiles and geochemistry in a zone above the CO₂ injection zone (and above the main confining layer) to determine whether CO₂ is migrating past the confining layer as a result of the flood operation. This approach could detect CO₂ leaks from or around wells and CO₂ leaks through faults or other features. Activities would include establishing a profile of the current pressures above the injection zone in existing wells that are perforated at the appropriate interval; continued monitoring of the pressures above the injection zone; and sampling and analysis to determine geochemical parameters above the injection zone (APCI 2011).

Table 2.3-2 Proposed MVA Activities at West Hastings Research MVA Program (as of 10/2012)

Denbury Existing Commercial Operational Activities	MVA Program Activities
Integrity Testing	
Normal well review and remediation as needed prior to CO ₂ injection (CO ₂ flood) <ul style="list-style-type: none"> ■ Normal well surveillance and remediation procedure for active wells ■ Normal well surveillance and remediation procedure for plugged and abandoned (P&A) wells 	Additional surveillance of idle wells in/around the CO ₂ flood area via petrophysical logging (i.e., temperature logs) <ul style="list-style-type: none"> ■ Surveillance of P&A wells as needed via casing head gas monitoring to develop characterization data. Collect soil gas time lapse data for over two years at selected soil gas monitoring sites.
<ul style="list-style-type: none"> ■ Learning from experience in Fault Block A, and from well remediation in Fault Blocks B&C 	<ul style="list-style-type: none"> ■ Implement augmented near-surface soil gas/aquifer surveillance methods (methane, CO₂, noble gases/isotopes.)
<ul style="list-style-type: none"> ■ Additional surveillance of idle wells via petrophysical logging ■ Surveillance of P&A wells via casing head gas monitoring 	<ul style="list-style-type: none"> ■ Surveillance of P&A wells (groundwater monitoring plan via shallow [100-ft-deep] freshwater wells up-gradient & down-gradient). Verify depths and locations of wells.
<ul style="list-style-type: none"> ■ Surveillance of available and Denbury-owned water wells) 	<ul style="list-style-type: none"> ■ Sample available wells to obtain water chemistry and establish best test methods for testing rock CO₂/water interactions. Established methods would be used to complete wells in USDW interval and monitor for potential CO₂ migration
CO₂ Flood Conformance Monitoring	
Reservoir characterization <ul style="list-style-type: none"> ■ Normal Denbury approach to monitoring flood, including daily monitoring daily of pressure at well head, injection profiles, monitoring oil-producer well fluids at least monthly at test sites 	Additional reservoir modeling to confirm CO ₂ plume behavior <ul style="list-style-type: none"> ■ Augmented measures of conformance – Implement Annual vertical seismic profile (VSP) survey plan in Fault Blocks B&C
<ul style="list-style-type: none"> ■ Normal Denbury approach to flood implementation, e.g., if a well would not take the planned flood rate, acidize, reperforate, or inject at a higher rate in other parts of pattern 	<ul style="list-style-type: none"> ■ Augmented measures of conformance monitoring – Conduct surface and borehole gravity monitoring 3-4 times per year and gravity monitoring plan in Blocks B and C.
	<ul style="list-style-type: none"> ■ Augmented measures of conformance monitoring – Conduct repeat three-dimensional (3-D) seismic profiling
	<ul style="list-style-type: none"> ■ Augmented measures of conformance monitoring – Real-time monitoring of tubing pressure/increased intermittent monitoring of memory-gauge pressure to assess characteristics of the flood
	<ul style="list-style-type: none"> ■ Augmented measures of conformance monitoring - Collect natural geochemical tracers at wellheads
	<ul style="list-style-type: none"> ■ During first year of CO₂ flood, complete approximately two wells outside of flood phase area to monitor the possible migration of CO₂ and monitor elevation of pressure outside of completed injection patterns. Develop Blocks B&C phases from top of structure down-dip. Wells would become active in future phases of development.

Table 2.3-2 Proposed MVA Activities at West Hastings Research MVA Program (as of 10/2012)

Denbury Existing Commercial Operational Activities	MVA Program Activities
	<ul style="list-style-type: none"> ■ Augmented measures of conformance monitoring – Conduct time-lapse surveillance logging in approximately half of the selected injection wells in Block B and C well patterns every half year until flood begins to provide data for comparison with model predictions. Run spinner, temperature, and capacitance tool logs twice per year in oil producers and four times per year in injection wells for comparison with model predictions. Run tracer surveys on half of the injection wells twice per year. Run spinner, temperature, and capacitance tool logs twice per year in oil producers and four times per year in injection wells.
Above-Zone Monitoring Interval (AZMI) Monitoring	
<p>Identify idle or reentered wells that may need to be permanently decommissioned</p> <ul style="list-style-type: none"> ■ Identify wells with mechanical problems that are capable of being remediated and re-plug or remediate prior to start of injection. 	<p>Establish current pressure profile via repeat formation test (RFT)/perforate existing wells. Test, with the exception of wells completed in the Miocene units, to characterize the pressure field and select locations in the AZMI. Wells completed in the AZMI would be fitted with screens protecting any poorly consolidated Miocene formation materials from sanding over of well perforations. Evaluate pressures in Miocene wells to gauge containment. Install temperature monitoring equipment and monitor temperature changes.</p>
	<ul style="list-style-type: none"> ■ Install and maintain simple pressure gauges on completed monitoring wells ■ Conduct pressure interference testing to show hydrologic communication and area over which the AZMI provides evidence of containment BEG to collect/analyze pre-injection fluids and gases for geochemical samples. ■ Plug back idle/reenter wells in selected above-zone interval to create monitoring wells ■ Place instruments in plugged back idle/reentered wells in selected AZMI wells ■ If available, run one or more newly-developed tools may be used in a selected number of wells to identify permeability information relevant to potential CO₂ migration through fault zones and fluid changes in AZMI through casing prior to the Block B and C flood ■ Monitor temperature to evaluate potential for natural or anthropogenic fluid migration behind casing of wells. If temperature anomalies are identified, additional logging may be warranted. ■ Identify four wells below the USDW interval and monitor for potential CO₂ migration

Table 2.3-2 Proposed MVA Activities at West Hastings Research MVA Program (as of 10/2012)

Denbury Existing Commercial Operational Activities	MVA Program Activities
	<ul style="list-style-type: none"> ■ Geophysical Logging – Conduct time lapse surveillance logging program involving selected idle wells and fault monitoring wells (monitoring wells penetrating or in close proximity to a fault zone) to obtain data to compare to baseline data as field is flooded. ■ Perform normal well surveillance, including monitoring casing pressures in injection wells and oil producers. Repair wells where integrity has been compromised, if necessary.
Fault Monitoring	
<p>Characterization of main fault bounding eastern edge of West Hastings Field;</p> <ul style="list-style-type: none"> ■ Conduct well logging program in idle wells in Blocks B&C 	<p>Perforate and monitor zones adjacent to the fault in wellbores that intersect the fault plane. Install and maintain simple pressure gauges to monitor for pressure anomalies. Existing wells would be utilized where practicable.</p> <ul style="list-style-type: none"> ■ Augmented measures of conformance monitoring – Baseline VSP survey. Current plan is for five 3-D VSP surveys in Fault Blocks B and C to image CO₂ fill-up through reservoir and above/below reservoir and along faults. Seismic monitoring may include Baseline VSP survey plus four repeats in later portion of Phase 2 activities in coordination with gravity logging (Denbury/BEG-supported activity). ■ Logging-Time lapse surveillance program including 20 selected idle wells and fault monitoring to obtain data to compare to baseline data as field is flooded. Monitor for fluid/temperature changes in fault zone monitoring wells

Source: Denbury 2012.

Key:

- AZMI = Above-zone monitoring interval
- P&A = Plugged and abandoned
- RFT = Repeat Formation Test
- USDW = Underground Sources of Drinking Water
- VSP = Vertical Seismic Profile

2.4 Construction Plans

The sections below describe the construction methods, resources required, and outputs, discharges, and wastes associated with construction of the components of the proposed project and connected action.

2.4.1 LCCE Gasification and Lake Charles CCS CO₂ Capture and Compression

Construction of the LCCE Gasification plant and the CO₂ Capture and Compression facility would occur together. Construction would begin with foundation and civil engineering work, the fabrication and installation of underground piping and electrical conduits, and the fabrication and

erection of structural steel and buildings. Activities at the peak of construction would include equipment installation, fabrication, installation of aboveground piping, hydro-testing, electrical installation, instrumentation loop checks, and pre-commissioning. The last phase of construction would include the completion of electrical installation, instrumentation checks, and pre-commissioning activities.

Site preparation activities for the LCCE Gasification plant including clearing and grading commenced in January 2010. In addition, site preparation work to raise the site elevations to above the local 100-year and 500-year base flood elevations commenced in November 2010. The site's elevation will be raised approximately 11 feet above mean sea level (MSL) to minimize risks of flooding the site. These activities were authorized by the USACE permits (Lake Charles Harbor & Terminal District Consent No. DACW29-9-08 [May 30, 2008] and MVN-1998-03311-WY [August 18, 2008]) included in Appendix B.

Construction of the LCCE Gasification plant would begin in the first quarter of 2014 and take approximately 36 months to complete. Construction would be followed by a four to six month commissioning and start-up period to test that all process systems function properly and achieve project requirements. The number of construction workers would vary during the construction period, ranging from 15 to 900 persons during the various phases of construction. For both the LCCE Gasification plant and the Lake Charles Capture and Compression facilities, peak construction is expected to occur in month 18 and involve approximately 2,500 workers, of which 900 would be on the LCCE Gasification plant site. This estimate includes engineers, staff, consultants, site visitors, and construction personnel, but excludes shuttle and delivery drivers. The foundations for major pieces of equipment would likely overlay pile-driven reinforced-concrete piles. The driven concrete piles would serve as the load-support elements beneath a reinforced concrete pad for each major process unit. Leucadia would perform most construction activities during a single shift between 7:00 A.M. and 5:30 P.M., Monday through Friday. Additional hours or a second shift may be necessary to complete critical activities.

In addition to the LCCE Gasification plant site, construction would occur at other locations. Off-site construction activities would include the construction parking area, equipment laydown area/methanol and sulfuric acid storage area, and linears for hydrogen, natural gas, raw water, potable water, electricity, and methanol and sulfuric acid storage, as shown on Figure 2.3-1. The methanol and sulfuric acid storage area, utility routes, and pipeline routes were described in Section 2.3.1.1. The parking area for construction workers would be located approximately 3 miles from the site, as shown on Figure 2.3-1. The area is currently cleared. Leucadia would grade the parking area for storm water management and install a gravel cover suitable for parking. The equipment laydown area would be located a short distance from the LCCE Gasification plant site. Leucadia is in the process of identifying and leasing a parcel of up to 40 acres required for staging and laydown for materials and equipment. Leucadia would use the siting criteria described in Section 2.3.1 to select a proposed site within 1 mile of the LCCE Gasification plant. After construction, the equipment laydown area would be converted to the methanol and sulfuric acid storage area.

Standard pipeline construction would proceed in the manner of an outdoor assembly line and consist of specific activities that make up the linear construction sequence. These operations would include surveying and staking of the ROW, clearing and grading, trenching, pipeline

stringing and bending, welding and coating, lowering-in and backfilling, hydrostatic testing, and cleanup and restoration.

Construction techniques may include excavated trenching, boring, tunneling, and horizontal directional drilling (HDD). Typical pipeline construction equipment would include pipelayers, excavators, trenching machines, mobile cranes, bulldozers, motor graders, dump trucks, front-end loaders, portable welding rigs, radiographic inspection equipment, pipe bending machines, water pumps and filters, transport trucks, and crew vehicles. During pipeline construction, materials would be staged adjacent to the pipeline ROWs or trucked in as necessary. The construction method for installing the pipeline would depend on the aboveground activities being crossed. The HDD method requires two large staging areas, one on each side of the crossing (the entry point staging area and the exit point staging area). The procedure would involve drilling a pilot hole, which would then be successively reamed in to achieve the required diameter borehole. The prefabricated pipe segments would then be pulled back through the borehole in one continuous motion. The HDD process involves the use of a drilling fluid, also referred to as drilling mud, which is generally composed of 95 to 98 percent fresh water, 2 to 5 percent bentonite (a naturally occurring clay), and a small amount of extending polymer (polyacrylamide). The HDD operation is a closed system to minimize the discharge of drilling mud, fluids, and cuttings outside of the work area. Drilling mud that inadvertently exits at points other than the entry and exit points would be contained and collected by Denbury to the extent practicable.

During construction, construction safety policies and programs and emergency services would be coordinated with the local fire departments, police departments, paramedics, and hospitals. A first aid office would be provided on site for minor incidents. Trained and certified health, safety, and environmental personnel would be on-site to respond to and coordinate for emergencies. All temporary facilities would have fire extinguishers, and fire protection would be provided in work areas where welding work would be performed.

2.4.1.1 Resource Requirements

Construction Materials

The majority of the construction materials would consist of steel, concrete, wood, fuel, and steel. Locally obtained materials would include crushed stone, sand, and lumber for the proposed facilities and temporary structures (e.g., enclosures, forms, and scaffolding). Components of the facilities would also include concrete, ductwork, insulation, electrical cable, lighting fixtures, and transformers. Materials would be shipped from their point of origin by various means, including, rail, truck, barge, and ocean-going vessels.

Equipment and Vehicles

Major components including the gasifier, AGR, and ASU would be transported from international locations via ocean-going vessels and delivered to the Port of Houston or the Port of New Orleans. Barges would transport equipment from the ports through the Intracoastal Waterway or the Gulf of Mexico into the Calcasieu River ship channel and offloaded at the LCCE Gasification site. Conventional building supplies would be delivered by truck.

Construction equipment used on-site during foundation installation would typically include mobile pile-driving rigs and support trucks, cranes of various sizes, generators, tractors, and

excavators, as well as smaller equipment such as backhoes, dump trucks, compactors, compressors, forklifts, man-lifts, and welding equipment. The number and size of cranes to be used would vary over the course of construction, with small- to medium-sized cranes used to offload and erect equipment items such as heat exchangers, pumps, and compressors. During the erection of the gasifiers, one or more larger cranes would be employed.

Vehicles entering or on the site during construction would include worker shuttle buses and trucks transporting materials within and into the site. Leucadia would use up to six 40-passenger shuttle buses to transport the construction workers from the remote parking area(s) to the LCCE Gasification plant construction site using multiple routes that would avoid railway crossings and high-volume commuter traffic routes. On-site vehicles would include dump trucks for hauling soil, stake trucks for hauling supplies, and water trucks for watering roads. The average number of dedicated on-site construction vehicles is estimated to be about 55 per day, with about 80 vehicles per day during peak activity (Leucadia 2011d). Small vehicles (i.e., golf carts) represent about half of the vehicles that would be dedicated to the site. Vehicles from offsite would include concrete, asphalt, and equipment delivery trucks. During foundation work, 150 construction vehicles would enter and leave the site.

Water

During peak construction, an average of three water trucks would use a total of approximately 6,000 gallons of potable water per day for dust control, concrete mixing, cleaning, and sanitary use. The City of Sulphur would upgrade an existing potable water pipeline to supply approximately 20,000 gallons per day to the LCCE Gasification plant. Metered fire water would be provided by the City of Sulphur for fire protection. One water truck would use approximately 2,000 gallons of potable water per day for dust suppression at the off-site parking area.

Leucadia would use water for hydrostatic testing of pipelines. Hydrostatic testing is performed to determine whether a pipeline is capable of operating at design pressures; successful completion of the test demonstrates the integrity of the constructed system. Pipeline integrity is tested by capping pipeline segments with test manifolds, filling a capped segment with water, subjecting the water to pressure, and monitoring the pressure. Hydrostatic testing of the pipe is performed in multiple segments and will address the entire pipeline. Hydrostatic test water would be withdrawn from Bayou D’Inde, the Sabine Canal, and municipal sources. As shown in Table 2.4-1, approximately 682,000 gallons of water would be used for hydrostatic testing of the pipelines associated with LCCE Gasification (Leucadia 2012b).

Table 2.4-1 Hydrostatic Test Water Estimates for Each LCCE Gasification Plant Pipeline

Linear	Volume (Gallons)
Methanol and Sulfuric Acid Pipeline to Storage	55,050
Natural Gas	19,500
Potable Water	1,250
Water Supply	193,600
Hydrogen	412,890
Total	682,290

2.4.1.2 Outputs, Discharges, and Wastes

Storm Water and Wastewater

During construction, disturbed land is susceptible to erosion causing discharge of soil and other contaminants. The erosion and sedimentation control plan developed for the LCCE Gasification site includes a best management practices for storm water runoff from construction areas, including a storm water retention pond design to hold the 10-year 24-hour storm.

Leucadia would discharge hydrostatic testing water using energy dissipation and filtration devices and locate discharge points within well-vegetated upland areas adjacent to the construction corridor. Leucadia would monitor and test discharges to properly characterize the waste prior to disposal under a Hydrostatic Test Discharge Permit.

Air Emissions

Emissions produced during construction would consist of exhaust emissions from construction-related equipment and worker and delivery vehicles, and dust generated during soil-disturbing activities. Typical pollutants emitted in the exhaust of construction equipment include nitrogen dioxide (NO₂), sulfur dioxide (SO₂), carbon monoxide (CO), carbon dioxide (CO₂) volatile organic compounds (VOCs), and particulate material smaller than 10 microns and 2.5 microns in diameter (PM₁₀ and PM_{2.5}, respectively).

Wastes

Construction of the proposed project would generate typical construction wastes, shown in Table 2.4-2. The principal waste streams would include equipment packaging, used lube oils, surplus materials, and empty containers. Solid wastes would be collected for disposal in an off-site licensed waste disposal facility. Scrap and surplus materials and used lube oils would be recycled or reused to the maximum extent practicable. The estimated amount of solid waste that would be generated during construction is 2,640 cubic yards over 36 months, or approximately 2 standard 40-cubic-yard (CY) bins every month. Small quantities of potentially hazardous materials and wastes (e.g., fuels, oils, lubricants, and solvents) would be stored in appropriate containers in a secure location on site. Approximately 10 portable toilets would be maintained by a local contractor during construction.

Wastes generated during construction of the proposed pipelines associated with the LCCE Gasification plant would primarily consist of nonhazardous materials, including land clearing waste, packaging materials, general refuse, and HDD fluids. Drilling mud associated with HDD crossings would be land farmed, if possible, or disposed of in commercial disposal facilities.

Leucadia, and its contractors, would be responsible for the proper handling and disposal of construction wastes. These requirements include waste minimization and the proper handling, storage, and disposal of hazardous and non-hazardous wastes.

Table 2.4-2 Wastes Generated during Construction of LCCE Gasification and Lake Charles CO₂ Capture and Compression

Non-Hazardous Wastes	Potentially Hazardous Wastes
<ul style="list-style-type: none"> ■ Concrete, cinder blocks, drywall (sheetrock, gypsum, or plaster), masonry, asphalt and wood shingles, slate, and plaster ■ Forming and framing lumber, plywood, wood laminates, wood scraps, and pallets ■ Steel, stainless steel, pipes, rebar, flashing, aluminum, copper, brass, structural steel, and steel utility poles ■ Brick ■ Siding ■ Electrical wiring and conduit ■ Non-asbestos insulation ■ Wood, sawdust, brush, trees, stumps, earth, fill, rock, and granular materials ■ Treated wood, including lumber, posts, ties, decks, and utility poles 	<ul style="list-style-type: none"> ■ Waste paints, varnish, solvents, sealers, thinners, resins, roofing cement, adhesives, machinery lubricants, and caulk ■ Drums and containers that once contained the items listed above

2.4.2 Lake Charles CCS Project CO₂ Pipeline

Construction of the CO₂ pipeline would be completed by Denbury in the third quarter of 2014. Construction would include installation of the pipeline within the construction ROW, temporary use of pipe storage yards, and construction of the metering and valve facilities. Construction would progress along the linear route, and no location along the ROW would be impacted for more than 3 months.

Standard pipeline construction would proceed in the manner of an outdoor assembly line and consist of specific activities that make up the linear construction sequence. These operations would include surveying and staking of the ROW, clearing and grading, trenching, pipeline stringing and bending, welding and coating, lowering-in and backfilling, hydrostatic testing, and cleanup and restoration. Clearing and grading would generally be conducted in a single pass for a given pipeline spread (CH2M Hill 2010). Construction phase would require an average of approximately 100 workers, with the total number of construction workers reaching 250 at peak construction times.

Construction techniques may include excavated trenching, boring, tunneling, and HDD. Typical pipeline construction equipment would include pipelayers, excavators, trenching machines, mobile cranes, bulldozers, motor graders, dump trucks, front-end loaders, portable welding rigs, radiographic inspection equipment, pipe bending machines, water pumps and filters, transport trucks, and crew vehicles. During pipeline construction, materials would be staged adjacent to the pipeline ROWs or trucked in as necessary. The pipeline would cross Bayou D’Inde Road, Bayou D’Inde, several roadways, Interstate 10, U.S. Hwy 90, rail lines, High Hope Road, and Bankens Road and terminate at an interconnect with the existing Green Pipeline. The construction method for installing a pipeline depends on the aboveground activities being crossed. The typical depth for a road crossing is at least 5 feet below the road bed, and a river/stream crossing is least 20 feet below the road or stream/river bed. The pipeline would cross under Bayou D’Inde using the HDD installation method. Actual HDD depths would

depend on the length of the drill, the maximum allowed curvature of the pipe based on diameter and wall thickness, and the minimum clearance and depth required to avoid any obstructions. After crossing Bayou D'Inde, the pipeline route would progress north using conventional trenched construction methods and then cross under Interstate 10 using HDD installation method. The pipeline would be trenched in place and be buried with at least 3 feet of cover or 4 feet near any buildings located within 50 feet of the pipeline. The pipeline would cross under State Highway 90 using a horizontal bore. The route would also cross Houston River Road and the Houston River using the HDD installation method. Where the route would parallel an existing power transmission corridor for approximately 1.75 miles, construction includes installation of an alternating current (AC) mitigation technology in the trench to protect from stray current from the power transmission lines that could impact the integrity of the steel pipe.

In actively cultivated agricultural areas, Denbury would work with landowners prior to construction to identify irrigation pipelines or drain tiles within the construction ROW and would develop irrigation crossing standards that are satisfactory to the affected landowners. When working in residential areas, Denbury would coordinate with the appropriate landowners to develop the required site-specific measures. Disruptions would be minimized to the extent practicable. Homeowners or business owners would be notified in advance of construction activities and any scheduled disruptions of utilities. Cleanup would occur promptly following construction activities. After cleanup, a Denbury representative would contact landowners to confirm that the conditions of all landowner agreements have been met (CH2M Hill 2010).

Temporary and Permanent ROWs

Pipeline installation would require the use of temporary construction ROWs. Denbury would use, to the maximum extent practicable, existing roads to access the pipeline ROW and would construct temporary access roads in areas without existing access to the pipeline ROW. Where the pipeline lateral would parallel existing foreign pipelines or utility ROWs, Denbury's new permanent ROW would be 50 feet wide, abutting the adjacent existing ROW, and an additional 45 feet of temporary construction ROW would be located on the side opposite from the existing utility corridor. For the portion of the pipeline ROW that would not be adjacent to an existing foreign pipeline or utility corridor, the total construction ROW would be 95 feet wide, of which 50 feet would be new permanent ROW (CH2M Hill 2010).

Temporary Workspace and Aboveground Facilities

Construction activities for the proposed pipeline would require a temporary office/warehouse yard and a pipe storage yard. Both proposed sites were previously used for similar construction/industrial activities and land uses. Denbury would use the sites to store pipe and equipment for the proposed pipeline and to provide areas for contractor temporary office space. Denbury would use the warehouse and pipeyard on a temporary basis and, following construction, would restore the site as appropriate and in concurrence with landowner requests. The warehouse yard consists of a 12.4-acre site located at MP 3.3, and the pipeyard consists of a 6.9-acre site at MP 0.6 (CH2M Hill 2011b). Additional temporary workspace outside the 95-foot-wide temporary pipeline construction corridor would typically be required at specific locations, such as areas where special construction techniques would be used (e.g., at crossings of wetlands, waterbodies, roads, and railroads; HDD sites; and near electric transmission lines), at tie-ins with existing pipeline facilities, at pipeline crossings, and in areas where the storage of stripped topsoil is required. During the installation of aboveground facilities, Denbury would

confine construction activities and the storage of construction materials and equipment to the pipeline construction ROW or approved temporary workspace areas (CH2M Hill 2010).

2.4.2.1 Resource Requirements

Equipment and Vehicles

Construction equipment would typically include excavators, as well as smaller equipment such as backhoes, dump trucks, compactors, compressors, and welding equipment. Work crews would operate at different points along the pipeline route and would park up to 50 vehicles at staging areas or at designated work locations along the pipeline route during the day.

Approximately 20 pipeline inspectors would use up to 10 trucks to travel from one segment of the pipeline to the next daily during construction. Construction of the pipeline would not restrict traffic flow on roadways except for limited periods during pipeline installation underneath roadways. Access to the temporary and permanent pipeline ROWs and associated facilities would be through existing public and private roads to the extent practicable.

Water

Water would be used for hydrostatic testing of the pipeline. Hydrostatic testing of the pipe would be performed in multiple segments and would address the entire pipeline. Denbury would obtain hydrostatic test water from local waterbodies and municipal sources. Denbury would directly pump water from local waterbodies and use trucks to transport hydrostatic test water obtained from municipal sources to the proposed pipeline. Water used for hydrostatic testing would be reused for subsequent pressure tests, if practicable. Denbury would use approximately 550,000 gallons of water for hydrostatic testing of the CO₂ pipeline.

2.4.2.2 Outputs, Discharges, and Wastes

Storm Water and Wastewater

Pipeline trench excavation and HDD activities would disturb soils, which may then be collected in storm water runoff. For small projects, the limited size of the pipeline would not require storm water conveyances. Denbury would submit a Notice of Intent to discharge Construction Storm water (CSW-G) to the LDEQ if required. Denbury would develop and implement best management practices to minimize potential storm water runoff impacts on surface water during construction of the CO₂ pipeline.

Denbury would discharge hydrostatic testing water discharged using energy dissipation and filtration devices (CH2M Hill 2011b). Discharge points would be located within well-vegetated upland areas adjacent to the construction corridor. Denbury would monitor and test discharges to properly characterize the water prior to disposal under a Hydrostatic Test Discharge Permit.

Air Emissions

Emissions produced during construction of the CO₂ pipeline would consist of exhaust emissions from construction-related equipment and dust generated during soil-disturbing activities.

Typical pollutants emitted in the exhaust of construction equipment include NO₂, SO₂, CO, CO₂, VOCs, PM_{2.5}, and PM₁₀. Table 4.2-8 provides estimates of construction emissions for the CO₂ pipeline.

Wastes

Wastes generated during construction of the proposed CO₂ pipeline would primarily consist of nonhazardous materials, including land clearing waste, packaging materials, general refuse, and HDD fluids. Drilling mud associated with HDD crossings would be land farmed if possible or disposed in commercial disposal facilities. Denbury would arrange for acceptable off-site disposal (e.g., at landfills, other construction areas needing fill material, etc.) of any debris that is not suitable for placement on the ROWs.

2.4.3 West Hastings Research MVA Program

Denbury currently performs CO₂ injection for EOR and ongoing commercial monitoring activities in the West Hastings oil field. As part of its commercial operations, Denbury constructed new facilities and drilled or reworked existing wells in the West Hastings oil field for CO₂ EOR, production of oil and gas, testing, water production, and brine disposal. As the West Hastings oil field is developed for commercial EOR, Denbury's ongoing EOR activities will include the reworking of existing and construction of new facilities as needed. Denbury's commercial EOR activities are an ongoing operation and are not evaluated in this DEIS.

Denbury would not drill any new wells or construct any new facilities for the West Hastings research MVA program. Denbury and BEG would conduct the West Hastings research MVA activities using existing wells for monitoring wells and access these wells from existing roads.

2.5 Operation Plans

2.5.1 LCCE Gasification Plant

Leucadia would design the LCCE Gasification plant for continuous full-load operation, with capacity reduced during process or compressor maintenance cycles. As described in Section 1.2, although operations would commence after the expiration of the Recovery Act funding, Leucadia would provide DOE with information necessary to determine whether the commercial-scale technology operations at the LCCE Gasification plant are making progress toward the capture and sequestration of 75% of the CO₂ from the treated stream, comprising at least 10% of CO₂ by volume, which would otherwise be emitted to the atmosphere. The LCCE Gasification plant would continue to operate until decommissioned by Leucadia. The demand for CO₂ would be expected to continue for the life of the gasification plant, which is typically 30 years. The CO₂ capture, compression and connector pipeline facilities would continue operations for the life of the gasification plant or for the duration of the demand for CO₂ to be used in EOR within the region.

Operation of the LCCE Gasification plant would require 187 operations and maintenance personnel. The workers would include a mix of plant operators, skilled craftsmen, managers, supervisors, engineers, and clerical workers.

Gasifiers would be started using methanol to minimize SO₂ emissions (Leucadia 2012a). During start-up of each of the gasifiers, syngas would be vented and combusted in a flare (Leucadia 2011b). Initially, syngas from the gasifier would be vented to the flare, and the flare valve would be gradually closed as normal operating conditions commence. The cooled, shifted syngas would next flow through the AGR system and hydrogen production. It may be necessary to vent the CO₂ stream to the flare until the composition of the CO₂ stream has stabilized. The syngas from the AGRs would be fed into a methanol synthesis process to produce methanol. The

sulfide components of the acid gases from the AGR would be sent to the WSA unit to recover sulfur as concentrated, commercial-grade sulfuric acid.

If either CO₂ compressor is not operating (e.g., during maintenance cycles), its CO₂ stream would be redirected to one of the regenerative thermal oxidizers, which would thermally destruct greater than 99% of the residual CO, H₂S, COS, and methanol contained in the CO₂ stream before discharging it to the atmosphere. The LCCE Gasification Plant is permitted for continuous operation of the thermal oxidizers and release of the CO₂ stream to the atmosphere when one or both of the CO₂ compressors are not operating due to maintenance or repair (CH2M Hill 2010).

Approximately 81 vehicles would access the site daily to remove waste materials for disposal, export materials, or to deliver process materials, fuel, lubricants, and water and wastewater treatment materials. Methanol would be shipped from the methanol storage tanks to buyers using multiple modes of transportation, including trucks, railcars, barges, and ships. On average, the shipping of methanol would involve 8 to 10 trucks and 6 to 8 railcars per day, 10 to 30 barges per month (depending on the size of the barges), and approximately 1.5 ships per month (Leucadia 2012a).

2.5.1.1 Resource Requirements

Table 2.5-1 summarizes the major resources required for operation of the LCCE Gasification plant. These resources are described below.

Table 2.5-1 Resource Consumption for Operation of LCCE Gasification and Lake Charles CCS CO₂ Capture (annual unless otherwise specified)

Resource	Quantity ¹
Petroleum coke	6,679 tons per day
Fluxant	200 tons per day
Aqueous ammonia	5,500 gallons per day
Natural gas	4.16 mmscf
Water	8,500 GPM
Power (from Entergy)	80 MW
Fuel (vehicles and equipment)	175 gallons per day

¹ Estimate based on full-load operation.

Key:

GPM = gallons per minute
 MW = megawatts

Petroleum Coke

Petcoke is a by-product produced by the refining of crude oil, particularly for producing gasoline (OSHA 2011). Because of its high carbon content, petcoke is mainly used in power and cement plants worldwide. Leucadia estimates that approximately 20% (0.5 million tons per year) of the petroleum coke will be locally produced petroleum coke already arriving at the Port of Lake Charles. The remaining 80% of the petroleum coke needed (approximately 2.1 million tons per year) would primarily come from other ports in the U.S. Gulf of Mexico (USGM) region. Leucadia identified sources of petroleum coke shipping from five USGM ports of Pascagoula, Mississippi; New Orleans, Louisiana; and Port Arthur, Houston, and Corpus Christi, Texas.

Fluxant

Fluxant materials would be added to the gasifier fuel supply to control and maintain the proper slag fluid temperature and viscosity on the walls of the gasifiers. The principal components of the fluxant are calcium and silica, which are found in materials such as sand, limestone, coal-fired boiler ash, and recycled material such as asphalt, auto glass, and window glass. The selected material would be stored in piles or silos until fed into the petcoke feed conveyor system (Leucadia 2011g).

Aqueous Ammonia

Leucadia would use aqueous ammonia to control emissions of nitrogen oxides in selective catalytic reduction equipment on the WSA facility and the boilers used for onsite power generation. Aqueous ammonia would be stored on site in two 33,000 gallon tanks.

Natural Gas

Leucadia would use natural gas in various processes to generate heat and steam. Hot combustion gases would preheat individual gasifier units or cure refractory. When used in the thermal oxidizer, the natural gas would support destruction of gaseous waste streams from the AGR unit. Leucadia would also use natural gas as a pilot fuel for the flare, as a supplementary fuel to the auxiliary boiler, and as a supplementary fuel for combusting vented gases.

Water

Leucadia would use water for cooling tower makeup, operation (service water), and fire protection. Equipment throughout the process requires cooling, including the gasifier, AGRs, and compressors (Leucadia 2012a). LCCE Gasification would obtain water from the SRA's existing pump house on the Sabine River Diversion Canal and transport the water via a new water supply pipeline. The water would be treated to the required quality using a clarifier; additional treatment would depend on the use of the water. Potable water would be supplied from the City of Sulphur.

Power

Leucadia would purchase power from Entergy Louisiana, LLC, and generate power onsite. Steam generated from heat recovery would provide a significant portion of the energy needs of the LCCE Gasification plant (Leucadia 2012a). The LCCE Gasification plant would provide approximately 86 MW to the CO₂ capture and compression facilities based on an availability of 92.5% (Leucadia 2012c).

Fuel and Chemicals

In order to maintain operations, water treatment chemicals, diesel fuel for fire water pumps and emergency generators, and gasoline for plant vehicles would be handled or stored on-site. Water treatment chemicals that may be added during pretreatment of the raw water supply include aluminum sulfate (alum), sodium hypochlorite (bleach), and polymer flocculants. Chemicals that may be added to the cooling water include sulfuric acid, chlorine, sodium bisulfite, dispersant (proprietary), scale inhibitor (proprietary), and a non-oxidizing biocide (on an as needed basis). Chemicals that may be added during reverse osmosis/demineralization include citric acid, sodium hypochlorite, sodium hydroxide, trisodium phosphate (infrequent), ammonium hydroxide, sodium bisulfite, scale inhibitor (proprietary), sulfuric acid (only if LCCE generates

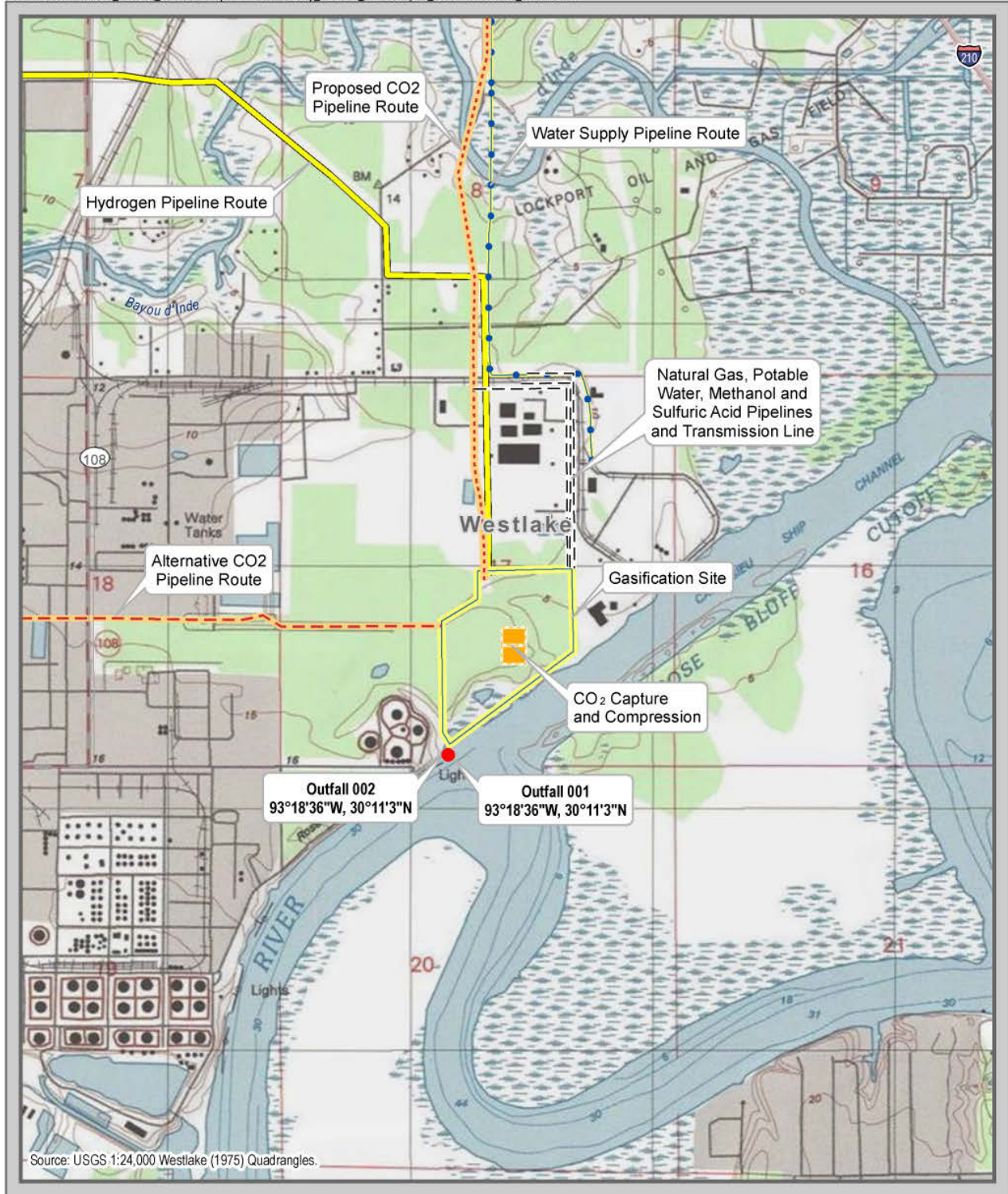

Source: USGS 1:24,000 Westlake (1975) Quadrangles.

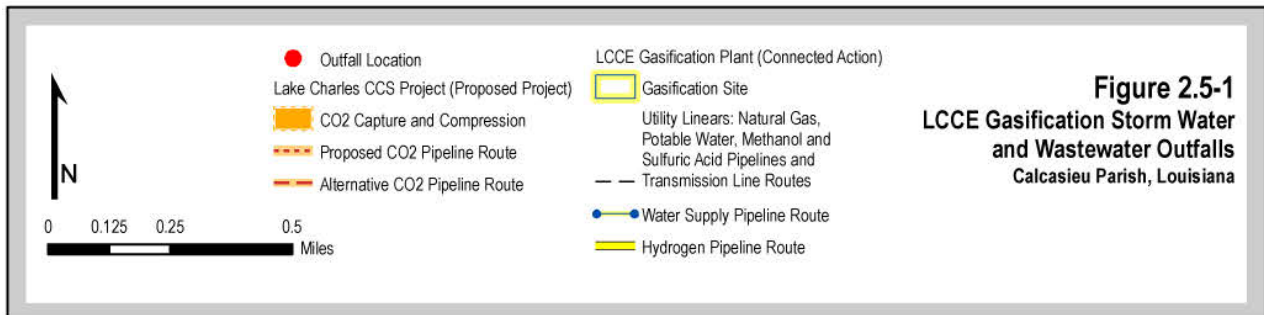

Figure 2.5-1
LCCE Gasification Storm Water and Wastewater Outfalls
 Calcasieu Parish, Louisiana

This page left blank intentionally.

mixed-bed resin on-site), and occasionally chemical additives to control pH and metals concentrations. Table 2.5-2 summarizes the types of storage for these materials. The tanks and totes would be aboveground storage tanks (ASTs) within curbed areas or with secondary containment with drains normally closed. Wash down water or materials collected from the curbed areas would be inspected prior to discharge or disposal.

Table 2.5-2 Storage of Water Treatment Chemicals for Operation of LCCE Gasification and Lake Charles CO₂ Capture and Compression

Name	Type of Storage
Aluminum Sulfate	Two 5000 gallon tanks
Polymer Flocc	400 gallon tote
Chlorine gas	1 ton cylinders
Polymer Flocc	200 gallon tote
Caustic Soda	5000 gallon tank
Sodium Bisulfite	400 gallon tote
Anti-Scale	400 gallon tote
Anti-Scale	3000 gallon tank
Bromide	5000 gallon tank

Diesel fuel, gasoline, and bulk lubricants would be stored in ASTs. Small amounts of specialty nonhazardous lubricants might be stored in smaller containers, such as 55-gallon drums. All ASTs and drum storage areas would be equipped with secondary containment to contain the 10-year, 24-hour rainfall event and spillage from leaks. ASTs would be inspected by staff routinely for leaks, corrosion, and other maintenance requirements in accordance with a site-specific spill prevention, control, and countermeasure (SPCC) plan.

There would be small amounts of paints, cleaners, adhesives, and other chemicals in spray cans stored on site for normal heavy equipment maintenance. Normally, less than 20 gallons of paint in pint, quart, gallon, or 5-gallon cans would be kept onsite. Spray cans of paints and cleaners would be kept in fireproof cabinets in the shop and would be completely used and decanted prior to disposal. Large vehicle and small rechargeable batteries would be recycled with a reputable battery recycler.

Leucadia would store and handle toxic or flammable materials in compliance with EPA and Occupational Safety and Health Administration (OSHA) regulations and the National Fire Protection Association’s “Guide on Hazardous Materials.” Leucadia would develop a SPCC Plan in compliance with federal and state regulations and worker safety programs to educate plant personnel regarding spill containment procedures. Secondary containment areas would be located throughout the site to isolate spills and any contaminated runoff from its surrounding area. Containment areas that contain oil would route spills and storm water runoff to the oily water separator for treatment prior to discharging off-site (Leucadia 2012a).

2.5.1.2 Outputs, Discharges, and Wastes

Table 2.5-3 summarizes the major outputs, discharges, and waste from operation of the LCCE Gasification plant. These outputs, discharges, and wastes are described below.

Table 2.5-3 Major Outputs, Discharges, and Wastes from Operation of the LCCE Gasification Plant and Lake Charles CO₂ Capture and Compression (annual unless otherwise stated)

Material	Quantity ¹
Outputs	
Methanol	4200 tons per day
Hydrogen, 99%	119 MSCF per day
Sulfuric Acid	421,000 tons
Carbon dioxide (CO ₂)	5.2 M TPY
Wastewater	
General industrial wastewater	412 GPM
Sanitary wastewater	13 GPM
Cooling tower blowdown	761 GPM
Air Emissions (tons per year)²	
Carbon dioxide CO ₂	642,400 ³
Particulate matter (PM ₁₀)	76
Sulfur dioxide (SO ₂)	132
Nitrogen oxide (NO ₂)	166
Carbon monoxide (CO)	524
Volatile organic compounds (VOCs)	14
Hydrogen sulfide	1
Sulfuric Acid	57
Methanol	9
Carbonyl sulfide	1
Ammonia	35
Wastes	
Gasifier slag	63,000 tons
Air filters for ASU	< 4,000 ft ³
Spent ASU molecular sieve and activated alumina	<1000 ft ³
Spent catalyst	<10,000 ft ³
Water treatment clarifier sludge filter cake (from treating river water)	<2,000 tons
Zero liquid discharge system solids	365 tons

- 1 The annual production quantities are based on estimated capacity factor and availability. Wastewater quantities based on average ambient conditions per the water balance.
- 2 Annual emissions are based on the June 2012 air permit, except for CO₂.
- 3 With CO₂ capture system operating.

Key:

- ASU = Air separation unit
- ft³ = cubic feet
- M = Million
- MSCF = million standard cubic feet

Methanol, Hydrogen, and Sulfuric Acid

Methanol, hydrogen, and sulfuric acid products are described in Section 2.3.1.1.

Storm Water and Wastewater

Leucadia would collect storm water, or rainfall runoff, from the gasification equipment area in a concrete storm water tank. The collected water would be reused (Leucadia 2011e). The tank would have a 1,000,000-gallon capacity to accommodate up to 6 inches of rainfall during a 24-

hour period. For process areas, Leucadia would collect the initial storm water runoff in a 125,000 gallon capacity tank, also for reuse. Storm water runoff from areas without potential for contamination from process areas would be directed to oil/water separators before discharge. Uncontaminated storm water collected from non-process areas, such as parking, would be discharged from on the west bank of the Calcasieu River to existing outfalls, as shown on Figure 2.5-1. Rainwater collected from secondary containment areas would be directed to oil/water separators before discharge.

Leucadia would implement zero liquid discharge (ZLD) for the gasification process wastewater, resulting in no discharge of gasification process wastewater. Wastewater generated in the gasification process would be treated and recycled to achieve ZLD through filtration, steam stripping, evaporation, and crystallization. Filtered solids and dewatered salts would be disposed of off-site at an approved disposal facility. Water in the stripper overhead stream containing most of the stripped ammonia would be condensed, and the ammonia-rich water would be used for either selective catalytic reduction of nitrogen oxides (NO_x) in the sulfuric acid plants or for petcoke slurry makeup water (Leucadia 2011f).

Industrial wastewater discharges would consist of non-contact cooling water blowdown from the circulating water system, reverse osmosis and demineralizer reject, and oil/water separator water (plant and equipment drains). The non-contact cooling water blowdown would discharge through Outfall 001 per the LDEQ pollutant discharge elimination system (LPDES) Permits (LA0124541 and AI No. 160213). On-site water treatment would consist of reverse osmosis and demineralization. Reverse osmosis and demineralizer reject water would discharge through Outfall 001. Water from the oil/water separator and equipment drains would discharge through Outfall 002 per the LPDES Permit. As shown on Figure 2.5-1, Outfalls 1 and 2 discharge to the Calcasieu River. Sanitary wastewater would be routed to the City of Sulphur municipal treatment system for treatment and disposal (Leucadia 2012a).

Air Emissions

Table 2.5-3 summarizes the emission limits for the LCCE Gasification plant during operation per the June 29, 2012, LDEQ air permit for the facility (PSD-LA-742 and 0520-00411-V0), except that CO₂ emissions reflect operation of the Lake Charles CCS project. The permit reflects emissions from operation of the pet coke handling and storage, gasifiers, cooling towers, process vents, flares, auxiliary boiler, thermal oxidizers, storage tanks, emergency generators, diesel pumps, and fugitive emissions. The permit includes maximum potential emission limits for criteria and hazardous pollutants from these sources. Criteria emissions means emissions from gasification of pet coke and fuel burning, which would include NO_x, VOC, CO, SO₂, and PM_{2.5}. Hazardous air emissions from the process include hydrogen sulfide, carbonyl sulfide, and ammonia.

If the Lake Charles CCS system is not operating, CO₂ would be vented to the atmosphere per the conditions of the LDEQ Air Permit for the LCCE Gasification plant. If CO₂ is not compressed and transported for use in EOR, each AGR unit would direct the CO₂ stream to a regenerative thermal oxidizer, which would thermally destruct greater than 99% of the residual CO, H₂S, COS, and methanol contained in the CO₂ stream before discharging it to the atmosphere. Fugitive emissions of gaseous compounds could be generated from the facilities due to leaks from equipment such as valves, compressor seals, and flanges or from storage tanks, including methanol and sulfuric acid. These emissions would be minimized by proper maintenance

practices. In addition, area gas detectors would be used to alert plant staff of fugitive gas emissions of hazardous air emissions.

Wastes

The primary solid waste stream would be slag, which is formed in the gasifier at temperatures above the melting point of the feed materials. The solid slag would consist of a wide range of particle sizes and would include some unreacted carbon. Slag is an inert glass-like material and a potentially marketable solid by-product. The physical form of slag is the result of gasifier operation at temperatures above the fusion, or melting, temperature of the mineral matter (DOE 2002). Slag would be conveyed from each gasifier to designated storage or disposal areas by trucks traveling on plant haul roads. Leucadia would dispose of slag as a nonhazardous by-product or sell it to various commercial markets.

Catalysts used in the CO₂ shift process in the AGR, methanation process, NO_x emission controls, and the Wet Sulfuric Acid process would be periodically removed and replaced. Catalysts may be disposed, or in some cases, regenerated. General office wastes (less than 100 cubic yards per year) would be disposed of in a permitted municipal or sanitary landfill by a licensed transporter. Solids from the ZLD process, estimated to be less than 1 ton per day (TPD) may be characterized as hazardous waste due to heavy metals concentrations and would be disposed off-site at a permitted disposal facility. Any wastes generated from operations or maintenance would be properly managed and disposed of off-site at an appropriately permitted facility.

2.5.2 Lake Charles CCS CO₂ Capture and Compression

Leucadia would design the Lake Charles CCS CO₂ Capture and Compression facilities for continuous full-load operation. Operation of the CO₂ Capture and Compression facilities would require 20 operations and maintenance personnel. If either CO₂ compressor is not operating (e.g., during maintenance cycles), its CO₂ stream would be redirected to one of the regenerative thermal oxidizers, which would thermally destruct greater than 99% of the residual CO, H₂S, COS, and methanol contained in the CO₂ stream before discharging it to the atmosphere.

2.5.2.1 Resource Requirements

The major resources required for operation of the Lake Charles CCS CO₂ Capture and Compression equipment are described below.

Methanol

The acid gas removal process uses methanol as a solvent to separate acid gases such as hydrogen sulfide and carbon dioxide from valuable feed gas streams. The methanol produced by LCCE Gasification would replenish any consumption of methanol in the AGR system and would be provided from the onsite methanol production tanks.

Propylene

Propylene is used as a refrigerant in the AGR to maintain the methanol at very cold temperatures. Propylene is an unsaturated organic compound having the chemical formula C₃H₆. Propylene is a byproduct of oil refining and natural gas processing. Propylene would be delivered once at start-up and used in a closed system.

Water

The LCCE Gasification plant would supply water to the Lake Charles CCS project CO₂ capture and compression facility's cooling system. The water consumed in the AGRs and CO₂ cooling system would comprise approximately 10% of the LCCE Gasification plant's raw water consumption and approximately 13% of the cooling tower capacity.

Power

As described above, Leucadia would purchase power from Entergy Louisiana, LLC, and generate power on-site. Simultaneous operation of both the LCCE Gasification plant and the CO₂ capture and compression facilities would require a net import of approximately 80 MW of electrical power.

2.5.2.2 Outputs, Discharges, and Wastes

Table 2.5-3 includes the major outputs, discharges, and waste from operation of the CO₂ capture and compression equipment. These outputs, discharges, and wastes are described below.

CO₂

The AGRs would be designed to achieve approximately 89% by weight CO₂ capture efficiency during steady-state operations. A portion of the remaining CO₂ would be converted to methanol and a portion would be vented to the atmosphere by the LCCE Gasification plant. The captured CO₂ would be transported to the Hastings oil field for sequestration in Denbury's ongoing commercial EOR operation.

Hydrogen Sulfide

The AGRs would produce a gas stream of approximately 45% hydrogen sulfide. The gas would be directed to the LCCE Gasification plant WSA Unit for conversion to sulfuric acid.

Storm Water and Wastewater

Leucadia would manage storm water from the CO₂ capture and compression equipment as described for the LCCE Gasification plant.

Wastes

The wastes produced by the Lake Charles CCS project CO₂ capture and compression facilities would include lubricating oils and filters commonly used in the operation of sophisticated rotating equipment. Typical waste would consist of one or two large canister oil filters changed once per year and replacement of 500 to 1,000 gallons of console oil every turnaround (3 years).

2.5.3 Lake Charles CCS Project CO₂ Pipeline

Denbury would design, operate, and maintain the CO₂ pipeline in accordance with the federal DOT Safety Standards in 49 CFR 195. The safety standards specified in 49 CFR 195 require the pipeline operator to develop and implement an emergency plan working in conjunction with local fire departments and other agencies. The emergency plan would: (1) identify personnel to be contacted, equipment to be mobilized, and procedures to be followed in response to a hazardous condition caused by the pipeline or associated facilities; (2) enable facility personnel to establish and maintain a liaison with the appropriate fire, police, and public officials to coordinate mutual assistance when responding to emergencies; and (3) establish a continuing education program to enable customers, the public, government officials, and those engaged in

excavation activities to recognize a CO₂ pipeline emergency and report it to appropriate public officials.

Operational testing would be performed on safety equipment to ensure proper function, and problems would be corrected immediately (CH2M Hill 2010). Maintenance of the pipeline would include periodic visual inspections and routine pedestrian surveys, as necessary, in accordance with applicable regulatory requirements and Denbury's Operation and Maintenance Manual. Post-construction surveys would identify erosion areas, exposed pipe, possible leaks, damaged or non-functional permanent erosion control measures, and other concerns that could potentially affect the environment and operation of the facilities. Leak inspections and cathodic protection maintenance would be conducted in accordance with DOT requirements and Denbury's internal requirements. Pipeline markers and signs would be inspected and maintained or replaced, as necessary, to ensure that the pipeline location at critical points is clearly identified. Maintenance of the pipeline would include periodic vegetation mowing to allow for visual pipeline inspections. ROW maintenance activities would normally be performed in late summer or early fall, during the driest season of the year. Regular maintenance activities for the new meter station and associated equipment would include calibration, inspection, and scheduled and routine maintenance.

2.5.3.1 Resource Requirements

Power

Electricity would be obtained from the existing electric distribution system adjacent to the proposed pipeline to power equipment, including main line valves without requiring upgrades or modifications. The meter station would obtain power from Denbury's existing electrical distribution system.

2.5.3.2 Outputs, Discharges, and Wastes

Air Emissions

The valve sites, meter station, and associated equipment on the CO₂ pipeline could potentially emit fugitive emissions. These emissions would have the same chemical composition as the CO₂ stream in the pipeline.

Wastes

During operation, the only waste would be that generated by clearing activities required to maintain the ROW in a condition accessible for vehicles. No solid or hazardous waste would be disposed of along the pipeline ROW. Any wastes generated from operations or maintenance would be properly managed and disposed of off-site at an appropriately permitted facility.

2.5.4 West Hastings Research MVA

The primary components of the research MVA program would be reworking or recompleting of wells, installation of monitoring equipment, data collection and performance testing, computer modeling, and analysis of data. Most of the activities related to the West Hastings research MVA program would be conducted at the existing West Hastings oil field in conjunction with ongoing, commercial EOR activities. Some analytical work, modeling, and other evaluations of the data would be performed at off-site locations, such as the BEG (Steve Walden Consulting and RDB Environmental Consulting 2010a).

In 2012, Denbury converted one existing well in the Frio formation to a monitoring well and converted two existing wells to above zone monitoring wells in the Miocene formation. In 2013, Denbury would convert one existing well in the Frio formation to a monitoring well and two existing wells to above zone monitoring wells in the Miocene formation. Depending on conditions at the existing well to be converted to a research MVA monitoring well, some site cleanup of vegetation at the existing well pad may be required prior to well conversion activities. Field work related to the well conversion activities would include fabrication and/or importation of temporary facilities and equipment (described below) placed at the ground surface within a previously disturbed area measuring approximately 150 feet by 150 feet in the immediate vicinity of each existing well to be converted. These temporary facilities and equipment would support activities required to convert existing wells to monitoring wells for the West Hastings research MVA program. Similar temporary facilities may be placed in the immediate vicinity of one or more existing wells, depending on the extent of any well conversion work required at each well (APCI, 2011)

All well conversion activities would be conducted on existing well pads using current access roads. Typically, the duration for conducting re-work/re-completion activities at a single well is on the order of approximately 3 to 4 weeks. Equipment which may be used to convert existing wells to monitoring wells for the West Hastings research MVA program includes workover rigs, portable pumps, portable steel tanks, and ancillary equipment. A workover rig is a mobile self-propelled rig used to perform remedial well work operations. These can include recompleting wells, adding perforations, downhole repairs, deepening and plugging back wells. Workover rigs are self-contained truck-mounted mobile units that travel between job sites on public roads. It typically consists of a large truck with a drawworks (large winch) and a telescoping mast built onto the bed and chassis. The truck is backed up to an existing well, the mast is raised and extended, and the work begins. At the conclusion of the work, the temporary facilities and equipment would be removed leaving only the existing access road and existing well pad around each wellhead.

Monitoring data would be obtained via existing wells. The Frio formation monitoring wells would have permanently installed instrumentation that allows for continuous monitoring of reservoir (Frio) pressure and temperature, surface tubing pressure, and casing pressures. The Miocene formation (AZMI) monitoring wells would also have permanently installed instrumentation that allows for continuous monitoring of the above-zone conditions. All monitoring wells would be logged periodically with conventional downhole logs to check for the presence of CO₂. Additional data would be collected via seismic imaging, gravity surveys, and soil gas and groundwater monitoring efforts at selected existing well sites. CO₂ injection volumes would be continuously measured at each injection well and monitored remotely as part of the ongoing EOR operation.

After the West Hastings research MVA program is completed, commercial EOR activities would continue. Denbury's normal commercial EOR activities include recompletions and reconditioning of existing wells, well integrity testing, modeling and monitoring of the CO₂ during injection of CO₂ and production of oil, and monitoring of pressures within the field for purposes of management of the EOR process.

2.5.4.1 Resource Requirements

The resources required for CO₂ injection in EOR are part of an ongoing operation and are not evaluated in this DEIS. The West Hastings research MVA program would use an existing power supply to operate monitoring and computer equipment.

2.5.4.2 Outputs, Discharges, and Wastes

Air Emissions

The primary emissions associated with the West Hastings research MVA activities would be from re-conditioning existing wells within the West Hastings oil field into monitoring wells. The emissions into the atmosphere from the well re-conditioning would occur from two general types of sources; emission from material handling (e.g., dirt moving) and emissions from internal combustion engines (gasoline and diesel) in mobile sources (off-road and on-road vehicles).

The material handling activities would result in emissions of fine particulate (particulate matter 2.5 microns or less, or PM_{2.5}). Site cleanup of existing well pads for the monitoring wells could include minor clean-up of overgrown weeds at the existing well pad. Other emissions may include entrained dust from construction equipment traveling on unpaved roads and surfaces in drilling areas (APCI 2011).

Mobile source emissions are separated into on-road (e.g., cars and trucks) and non-road emission categories. Emissions from these categories results from fuel combustion and as such would have emissions of NO_x, VOC, CO, SO₂, and PM_{2.5}. Non-road emissions result from the use of fuel in construction equipment (i.e., if any well pad enhancement is required) and the workover rig, if required. On-road vehicles would be used during the well conversion activities and would result in emissions of NO_x, VOC, CO, SO₂, and P M_{2.5}. On-road equipment may include heavy duty and light duty diesel vehicles, and heavy duty and light duty gasoline vehicles.

Wastes

Minimal quantities of drilling mud and associated wastes generated during the reconditioning of existing wells would be land farmed on-site in accordance with RRC regulations or disposed of in commercial disposal facilities. No other solid or hazardous waste would be produced during monitoring or testing operations during the West Hastings research MVA activities (Steve Walden Consulting and RDB Environmental Consulting 2010a).

2.6 Alternatives

2.6.1 Alternatives to DOE's Proposed Action

NEPA requires that agencies discuss reasonable alternatives to the proposed action. The purpose of and need for the federal action provide the context for defining reasonable alternatives.

2.6.1.1 Alternatives Considered during the Selection Process

DOE's alternatives to the Lake Charles CCS project consisted of the 83 technically acceptable applications received in response to the *Funding Opportunity Announcement, Carbon Capture and Sequestration from Industrial Sources and Innovative Concepts for Beneficial CO₂ Use (DE-FOA-0000015)*. The 83 applications were down-selected as discussed in Section 1.1.2 and this project was one of three selected from a field of eight proposed projects. Prior to selection, DOE made preliminary determinations regarding the level of review required by NEPA based on potentially significant impacts identified in reviews of acceptable applications. DOE conducted

these preliminary environmental reviews pursuant to 10 CFR §1021.216. These preliminary NEPA determinations and reviews were provided to the selecting official, who considered them during the selection process. A synopsis of the potential environmental consequences of the proposed projects is attached as Appendix A, in accordance with 10 CFR §1021.216(h).

Because DOE's proposed action is limited to providing financial assistance in cost-sharing arrangements to projects submitted by applicants in response to a competitive funding opportunity, DOE's decision is limited to either accepting or rejecting the project as proposed by the proponent, including its proposed technology and selected sites. DOE's consideration of reasonable alternatives is, therefore, limited to the technically acceptable applications and a no action alternative for each selected project.

2.6.1.2 No Action Alternative

Under the no action alternative, DOE would not provide funding to Leucadia. In the absence of financial assistance from DOE, Leucadia could reasonably pursue several options. Leucadia could build both the LCCE Gasification plant and the Lake Charles CCS project with funding from other sources. DOE assumes that if Leucadia builds the LCCE Gasification plant and Lake Charles CCS project in the absence of DOE cost-shared funding, the plant would include the same features, attributes, and impacts described. Alternatively, Leucadia could choose not to build all or parts of the LCCE Gasification plant and Lake Charles CCS project. For the purpose of making a meaningful comparison between the impacts of DOE providing and withholding financial assistance, DOE assumed that all or part of the LCCE Gasification plant and Lake Charles CCS project would not be completed without DOE funds. Therefore, the following sub-alternatives were identified and analyzed in the EIS:

1. Neither the LCCE Gasification plant nor the Lake Charles CCS project would be built, or
2. The LCCE Gasification plant would be built, but the captured CO₂ would be vented to the atmosphere and not sequestered in an ongoing EOR operation.

The ongoing commercial CO₂ EOR operations and the West Hastings research MVA program would continue under each of these no action options. In the absence of Leucadia's participation, Air Products would fund the entire non-DOE share of the research MVA program under a separate project agreement.

2.6.2 Project Alternatives under Consideration by the Applicant

Alternate CO₂ Pipeline Route

Two alternative pipeline routes, Alternative A (East Route) and Alternative B (West Route), and a preferred route were considered during the process of selecting the preferred pipeline route for the Lake Charles CCS project. Alternative pipeline routes A and B are shown on Figure 2.3-5. Each of the routes originates at the LCCE Gasification plant and terminates at interconnect points on the existing Green Pipeline. Alternative A (East Route) was dismissed from further consideration, as described below in Section 2.6.3.2 below.

Alternative B (West Route) originates at the LCCE Gasification plant and traverses a corridor south of Sulphur, Louisiana, in a westerly direction for approximately 5 miles. It then turns to the northwest for the remainder of the 11.6-mile-long route and terminates at the existing Green

Pipeline. The initial 5 miles of the West Route traverse an industrial area with little habitat that would support wildlife species (CH2MHill 2010). Alternative B (West Route) was carried forward for additional consideration.

2.6.3 Project Alternatives Dismissed from Further Consideration by the Applicant

2.6.3.1 LCCE Gasification Plant

Conventional Wastewater Treatment

Leucadia evaluated conventional wastewater treatment technologies and the Zero Liquid Discharge (ZLD) process for management of process wastewater. The ZLD process described in Section 2.5.1.3 would produce a wet sludge and is an alternative to conventional wastewater treatment that produces discharge water. The ZLD process eliminates the discharge of any gasification process wastewater to the environment.

2.6.3.2 CCS Project

CO₂ Capture

The AGR units would use Rectisol[®], the trade name for a methanol-based process that separates acid gases, such as H₂S, COS, and CO₂, from valuable feed gas streams. The Rectisol[®] offers a high level of sulfur removal compared to other technologies used for this purpose. Other sulfur-removal technologies, such as MDEA (methyl diethanolamine) and Selexol[™], which are commonly used in refinery and integrated gasification combined-cycle power applications, would not be able to achieve the level of CO₂ and sulfur removal required for the LCCE Gasification plant's methanation process.

CO₂ Compressors

Leucadia considered single-cylinder, between-bearing compressors and multi-cylinder, integrally geared compressors. The integrally geared compressor design was chosen based on efficiency and operating history.

CO₂ Pipeline Alternative Route

The East pipeline route originates at the Leucadia gasification facility and traverses a northerly route for the first 4 miles along a corridor east of Sulphur, Louisiana; it then turns to the northeast for approximately 2 miles before turning north again to its terminus at MP 12.2. The East route traverses industrial areas associated with the cities of Sulphur and Westlake for the first 6 miles before crossing more rural areas. The East route traverses Sam Houston Jones State Park at the Houston River crossing and again at the Calcasieu River. Sam Houston Jones State Park is predominantly pine-hardwood forest maintained in a natural state and is an attraction for birders, hikers, and fishermen. The East route terminates at the existing Green Pipeline. The East route was determined to be a potentially practicable alternative. However, based on an assessment of the environmental impacts that would be associated with the East route, Denbury concluded that the East Route would likely result in greater adverse impacts on perennial streams, wetlands, floodplains, and upland forest than the preferred pipeline route. Based on comparative desktop review of environmental features, the East route would contain nearly twice the number of perennial stream crossings as the preferred route and more 100-year floodplain impacts than any of the alternatives considered. Analysis also indicated that the East route contains 55.8 acres of wetlands (49.6 acres forested) within the construction corridor, compared

to 19.02 acres of wetlands (10.34 acres forested) on the proposed pipeline route (CH2M Hill 2011b).

Because the East route would cross more perennial streams, wetlands, floodplains, rivers, and public lands than the preferred pipeline route, the East route was eliminated from further consideration. Therefore, no further evaluation of the East route was performed.

This page left blank intentionally.

3. Affected Environment

3.1 Introduction

The affected environment is the geographic area that bounds the environmental, sociological, economic, or cultural resources potentially affected by the proposed project, the connected action, or the no-action alternatives. Given that the proposed project spans two states, this section provides an overview of relevant information for both Louisiana and Texas before describing resource-specific information. Generally, the affected environment includes the proposed LCCE Gasification plant, the CO₂ Capture and Compression facilities site, the CO₂ pipeline corridor, and the West Hastings research MVA program site.

The description of the existing environment for the LCCE Gasification plant and Lake Charles CCS CO₂ Capture and Compression facilities addresses all major components of construction and operation shown on Figure 2.3-1, including offsite activities associated with LCCE Gasification. Off-site activities include petcoke conveying from the Port, methanol storage and pipelines, sulfuric acid pipelines and storage, hydrogen pipeline, water supply pipeline, natural gas pipeline, electric transmission line, potable water line, construction equipment laydown area, and off-site construction parking. The existing environment for the LCCE Gasification plant and Lake Charles CCS CO₂ Capture and Compression facilities is described as a whole, except where a unique feature that is not common to the major components of construction and operation requires description. For the purpose of making a meaningful assessment of impacts, DOE used as the baseline the undisturbed land characteristics as documented at the proposed LCCE Gasification plant site. The clearing and grading of the site were performed in January 2010 in accordance with permits issued to the Port of Lake Charles, prior to project selection by DOE. These activities were considered as part of the resource area impacts evaluated in Chapter 4.

The extent of the geographic area described is generally unique for each resource, i.e., environmental, sociological, economic, or cultural depending on the extent of potential impacts on respective resources. Where possible, the extent of the geographic area is quantified; otherwise, it is illustrated with figures and described qualitatively, depending on the extent of potential impacts on respective resources.

This chapter is organized into sections for 12 resource areas, as listed below:

- Air Quality and Climate (Section 3.2)
- Geology and Soils (Section 3.3)
- Surface Water, Wetlands, and Floodplains (Section 3.4)
- Biological Resources (Section 3.5)
- Groundwater (Section 3.6)
- Cultural Resources (Section 3.7)
- Land Use (Section 3.8)
- Socioeconomic and Environmental Justice (Section 3.9)
- Traffic and Transportation (Section 3.10)
- Noise (Section 3.11)
- Wastes and Materials (Section 3.12)

■ Human Health and Safety (Section 3.13)

DOE used the best available information to describe the existing environment in the context of the project components. This includes prior DOE NEPA documents, data from federal and state agencies, and publicly available information. The description of the affected environment includes information directly related to the proposed project, the connected action, or the no-action alternatives that is necessary to assess or understand potential impacts. This information describes the baseline conditions from which environmental changes resulting from all alternatives will be identified and evaluated.

DOE evaluated the environmental impacts of the West Hastings research MVA program as part of the Environmental Assessment (EA) for the Air Products ICCS Project (DOE/EA-1846). In that EA, DOE described the existing environment and analyzed impacts on air quality, water resources, land use, geology and soils, biological resources, cultural resources, socioeconomics, environmental justice, and human health and safety. Since that document was released in 2011, additional design work has been completed, and additional detail is now available. This document reflects the most current design detail. Because the Air Products ICCS project proceeded and the West Hastings MVA is jointly funded by Air Products and Leucadia, some activities from the West Hastings MVA program have already occurred. Those activities which have already commenced are considered to be part of the existing environment for this analysis.

3.2 Climate and Air Quality

This section presents a synopsis of local climate and meteorological conditions at the sites in Louisiana and Texas and a review of existing air quality at both locations. Climate change impacts are an inherently cumulative effect, rather than a direct effect of the proposed project; therefore, a review of global, regional, and local greenhouse gas emissions and regulatory developments are discussed in Chapter 5, Cumulative Impacts.

3.2.1 Climate and Meteorology

Southwest Louisiana

The LCCE Gasification plant, the Lake Charles CCS project CO₂ Capture and Compression facilities, and CO₂ Pipeline are located within the same climate and meteorological regime in southwest Louisiana. The National Oceanic and Atmospheric Administration (NOAA) National Climatic Data Center provides annual maximum, minimum, and mean temperature and average precipitation data for the airport in Lake Charles, Louisiana (NCDC 2010a). Table 3.2-1 presents data for the period of record from 1971 to 2000. In addition to the data shown in Table 3.2-1, other pertinent weather data include:

- Annual average wind speed: 7.7 miles per hour,
- Prevailing wind direction: from the south (190 degrees),
- Maximum wind gust: 77 miles per hour, and
- Annual normal snowfall total: 0.3 inches.

Severe weather occasionally occurs in the area. The Lake Charles National Weather Service Office conducted a review of documented storms from 1886 through 1997 for a 150-mile radius around Lake Charles and provided findings in a 1998 report. During the 112 seasons studied, 71 tropical storms passed within the area, 34 of which were hurricanes. Of the 34 hurricanes, eight

were considered major (Categories 3 to 5 on the Saffir-Simpson Scale). This gives a frequency of one tropical storm through the area every 1.6 years, one hurricane every 3.3 years, and a major hurricane every 14 years. Since 1997 two major hurricanes have impacted the region causing severe damage: Hurricane Rita in 2005 and Hurricane Ike in 2008.

Table 3.2-1 Precipitation and Temperature (T) Data for Lake Charles, Louisiana, Airport (1971-2000)

	Jan	Feb	Mar	Apr	May	Jun	Jul	Aug	Sep	Oct	Nov	Dec	Year
Mean Precipitation (inches)	5.52	3.28	3.54	3.64	6.06	6.07	5.13	4.85	5.95	3.94	4.61	4.6	57.19
Mean Daily T (°F)	50.9	54.4	61.0	67.3	74.9	80.5	82.6	82.4	78.4	69.5	60.1	53.3	67.9
Normal Max T (°F)	60.6	64.5	71.3	77.4	84.1	88.9	91.0	91.3	87.7	80.5	70.6	63.3	77.6
Highest Daily Max T (°F)	82	83	90	95	99	102	102	107	105	94	87	82	107
Normal Min T (°F.)	41.2	44.3	50.8	57.2	65.7	72.1	74.3	73.6	69.1	58.6	49.7	43.3	58.3
Lowest Daily Min T (°F)	15	17	23	34	49	56	61	59	47	30	23	11	11

Source: NCDC 2010a

The historical tornado frequency for Lake Charles is near the Louisiana average for tornado activity and is 117% greater than the overall U.S. average. Approximately 76 tornadoes occurred in or near Lake Charles during the period from 1950 to 2003. Two notable events include: the February 12, 1971, Category 3 (maximum wind speeds of 158 to 206 mph) tornado that occurred 0.6 miles from the city center and caused approximately \$2.5 million in damage; and the April 17, 1973, Category 3 tornado that occurred 3.4 miles from the city center and caused between \$5,000 and \$50,000 in damage.

Texas Coastal Plains

The West Hastings research MVA site is located on the Texas Coastal Plains, a humid subtropical area near the Gulf of Mexico. Table 3.2-2 summarizes average climatic data for the National Weather Service station in Alvin, Texas, which is representative for the research MVA site (NCDC 2010b). In addition to the data shown in Table 3.2-2, other pertinent weather data include:

- Humidity is high; summer morning humidity values average over 90%, and afternoon values exceed 60%;
- Prevailing wind direction: from the south and southeast;
- Annual precipitation range: 30 to 60 inches.

Table 3.2-2 Precipitation and Temperature (T) Data for Alvin, Texas (1971-2000)

	Jan	Feb	Mar	Apr	May	Jun	Jul	Aug	Sep	Oct	Nov	Dec	Year
Avg. Precipitation (inches)	4.76	2.91	3.11	3.22	4.92	5.35	4.78	3.84	7.12	3.93	4.43	3.36	51.73
Mean Temp (°F)	52.7	55.9	62.5	68.5	75.5	80.7	82.7	82.7	78.7	70.6	62.2	54.9	69.0
Avg. High Temp (°F)	62.2	65.7	72.0	77.3	83.6	88.8	91.2	91.6	87.7	80.8	72.2	64.7	78.2
Avg. Low Temp (°F)	43.1	46.1	53.0	59.6	67.3	72.5	74.2	73.8	69.6	60.4	52.1	45.1	59.7

Source: NCDC 2010b

3.2.2 Regional and Local Ambient Air Quality

The Clean Air Act identifies “criteria pollutants” for which national ambient air quality standards (NAAQS) must be set, including sulfur dioxide (SO₂), particulate matter (PM₁₀ and PM_{2.5}), carbon monoxide (CO), and nitrogen dioxide (NO₂). State environmental agencies operate ambient air quality monitoring sites in accordance with the requirements of federal regulations and the EPA-approved Quality Assurance Program Plan. Air quality for a specific pollutant in a defined geographic area or region that meets or is better than the health standard is considered in “attainment.” Air quality that exceeds the health standard is considered in “nonattainment.”

Class I areas include areas of national or regional natural, scenic, recreational, or historic value and receive special air quality protection regulations. In these areas, ambient air is considered “pristine,” and almost no change from current air quality is allowed.

Criteria Pollutants
SO₂ (Sulfur Dioxide) - contributes to acid rain.
NO₂ (Nitrogen dioxide) – contributes to acid rain and formation of ozone.
O₃ (Ozone) - respiratory irritant.
PM_{2.5} and PM₁₀ (Respirable particulate) - inhalable, scatters sunlight, and reduces visibility.
CO (Carbon Monoxide) – affects oxygen absorption in lungs.
Pb (Lead) – can accumulate in blood, causing chronic health problems.

Calcasieu Parish, Louisiana

Calcasieu Parish is designated as an attainment area, meaning that it meets ambient air quality standards set for protection of public health. Table 3.2-3 provides information on the nearest monitoring sites in Calcasieu Parish, Louisiana, and Table 3.2-4 provides a summary of ambient monitoring data for the latest year available. The parish was historically designated as in marginal nonattainment for the 1-hour ozone standard. Air quality improved, and the parish was re-designated a maintenance area on May 2, 1997. However, under the rule implementing the 8-hour ozone standard (published on April 30, 2004), a maintenance plan is required to ensure that Calcasieu Parish maintains attainment with the 1-hour standard, even though a new 8-hour ozone standard was implemented.

Table 3.2-3 Active Ambient Air Quality Monitors

Monitoring Site	Location Coordinates	Pollutants Monitored
Carlyss 22-019-0002 Hwy 28 and Hwy 108	Latitude: 30.14 Longitude: -93.37	Ozone
Lake Charles McNeese University 22-019-0010 Common and E. McNeese	Latitude: 30.18 Longitude: -93.21	PM _{2.5}
Vinton 22-019-0009 2284 Paul Bellow Road	Latitude: 30.2383 Longitude: -93.58	PM _{2.5} , Ozone
Westlake 22-019-0008 2646 John Stine Road	Latitude: 30.26 Longitude: -93.28	PM _{2.5} , Ozone, SO ₂ , NO _x , VOCs
Lake Charles Lighthouse Lane SPECIAL3 Lighthouse Lane Bayou D'Inde Pass	Latitude: 30.22 Longitude: -93.31	VOCs

Source: 2009 Louisiana Annual Network Assessment, LDEQ AQ Assessment Division, May 30, 2009.

Table 3.2-4 2008 Ambient Air Quality Data for Calcasieu Parish

Pollutant	Concentration	NAAQS (statistic)
CO (8-hour) ¹	1.9 ppm	9 ppm (10 mg/m ³) (maximum)
CO (1-hour) ¹	2.9 ppm	35 ppm (40 mg/m ³) (maximum)
NO ₂ (Annual)	0.007 ppm	0.053 ppm (arithmetic mean)
NO ₂ (1-hour)	0.047 ppm	0.100 ppm (98 th percentile, 3-year average.)
Ozone (1-hr)	0.094 ppm	0.12 ppm (maximum)
Ozone (8-hr)	0.073 ppm	0.075 ppm (4 th highest daily maximum 8-hour, 3-year average)
SO ₂ (1-hr)	0.052 ppm	0.075 ppm (99 th percentile, 3-year average)
SO ₂ (3-hr)	0.01 ppm	0.5 ppm (maximum)
PM ₁₀ (24-hr) ²	61 µg/m ³	150 µg/m ³ (Not to be exceeded more than once per year, 3-year average)
PM _{2.5} (Annual)	9.32 µg/m ³	15 µg/m ³ (3-year average of annual arithmetic mean)
PM _{2.5} (24-hr)	20.9 µg/m ³	35 µg/m ³ (98 th percentile, 3-year average)

Source: EPA 2011a.

¹ Pollutant not monitored in Calcasieu Parish. Data from East Baton Rouge, closest CO monitoring site to Calcasieu Parish.

² Pollutant not monitored in Calcasieu Parish. Data averaged from West Baton Rouge monitor sites 1 and 2, closest PM₁₀ 24-hour monitoring site to Calcasieu Parish.

The maintenance plan submitted under Section 110(a)(1) of the Clean Air Act must provide control measures that work to continue to demonstrate attainment of the air quality standard (i.e., maintain attainment) for a period of 10 years after submittal and approval of the maintenance plan. Louisiana submitted the required Section 110(a)(1) maintenance plan. Calcasieu Parish has an effective date of designation for the 8-hour ozone standard of June 15, 2004, which means that maintenance must be demonstrated through 2014.

There are no Federal Class I areas within a 200-mile radius of the proposed project in Louisiana. The nearest Federal Class I area is the Breton National Wildlife Refuge (BRET1 Site), near Plaquemine Parish in southeast Louisiana, which is more than 354 kilometers (220 miles) from a portion of the site in Louisiana. The Wichita Mountains Wilderness Area in Oklahoma (WIMO Site) is more than 917 kilometers (570 miles) from the CO₂ Pipeline. *The Federal Land Managers AQRV Workgroup (FLAG) Phase I Report – Revised* (FLAG 2010) requires modeling of impacts from sources within 100 kilometers from a Class I area.

Brazoria County, Texas

The West Hastings research MVA site is located in Brazoria County, which is within the Houston-Galveston Metropolitan Statistical Area (MSA). The entire MSA, including Brazoria County, is currently listed as a severe 8-hour ozone non-attainment area. The Texas Commission on Environmental Quality (TCEQ) operates ambient air quality monitoring locations in the MSA, in addition to locations operated by local and private organizations. The air quality monitoring station nearest to the West Hastings research MVA site is at the Clear Brook High School in Friendswood, approximately 5.5 miles to the northeast (TCEQ 2010a). The monitor collects data on ozone and a suite of meteorological parameters. From 2006 to 2009, the station recorded several exceedances of the NAAQS for ozone. Other monitoring sites near the project area include the Manvel Croix Park station, which is approximately 8.5 miles west-northwest of the site, and the Mustang Bayou station, which is approximately 13.0 miles south-southeast of the site. These sites monitor for various nitrous oxides, as well as ozone and meteorological parameters.

With respect to Class I areas, the Caney Creek Wilderness Area (CACR1 Site) in Arkansas is located more than 611 kilometers (380 miles) from the West Hastings research MVA site.

3.2.3 Existing Emission Sources

The EPA’s National Emission Inventory (NEI) database contains criteria pollutant emission data for calendar year 2008, by county, throughout the United States. Emissions from all sources in a county or parish are summed by source type and reported in the NEI. Tables 3.2-5 and 3.2-6 show total criteria pollutant emissions by source type for Calcasieu Parish, Louisiana, and Brazoria County, Texas respectively.

Table 3.2-5 Criteria Pollutant Emissions in Calcasieu Parish, Louisiana (2008)

Source Type	Emissions(tons)				
	NO _x	VOCs	SO ₂	CO	PM _{2.5}
Industrial	7,539	10,324	17,435	5,550	3,064
Fuel combustion	18,246	553	27,702	5,209	1,680
Mobile	15,765	5,130	953	42,358	601
Dust	-	-	-	-	373
Miscellaneous	104	1,881	4	2,151	349
Fires	37	60	9	599	67
Agriculture	-	-	-	-	58
Solvent	-	8,517	-	-	1
Total	41,691	26,465	46,103	55,867	6,193

Source: EPA 2011b.

Table 3.2-6 Criteria Pollutant Emissions in Brazoria County, Texas (2008)

Source Type	Pollutant Emissions(tons)				
	NO _x	VOCs	SO ₂	CO	PM _{2.5}
Industrial	5,554	18,517	3,859	3,729	1,407
Fuel combustion	3,037	360	68	2,041	604
Mobile	13,004	3,462	1,279	32,456	562
Dust	-	-	-	-	3,732
Miscellaneous	289	1,407	12	8,423	1,143
Fires	-	-	-	-	-
Agriculture	-	-	-	-	-
Solvent	11	2,549	-	18	1
Total	21,895	26,295	5,218	46,667	7,449

Source: EPA 2011b.

3.3 Geology and Soils

3.3.1 Regional Geology

The proposed project areas lie within the Atlantic Plain Physiographic Division within the Coastal Plain Province in the West Gulf Coastal Plain Section (Fenneman and Johnson 1946; USGS 2003). Figure 3.3-1 shows the locations of the proposed project areas within the West Gulf Coastal Plain.

West Gulf Coastal Plain in Louisiana

Generally, the surface of the West Gulf Coastal Plain in Louisiana consists of Quaternary (Pleistocene and Holocene) sediment deposited in or adjacent to rivers and deltas in a coastal-plain setting. Approximately 55% of the surface of the state consists of alluvium of the Mississippi and other rivers and tributaries, and coastal marsh deposits. The alluvium consists of sandy and gravelly channel deposits mantled by sandy to muddy natural levee deposits and organically rich muddy back swamp deposits. Coastal marsh deposits are chiefly mud and organic matter. Approximately 20% of the state’s surface is occupied by Pleistocene terraces; the deposits associated with these terraces also consist of sand, gravel, and mud, which are underlain by raised, flat surfaces with varying degrees of tilt and dissection, depending on their relative ages. These surfaces are remnants of pre-existing floodplains and form terraces along both sides of major rivers in north Louisiana and coast-parallel belts in southern Louisiana. These surfaces were raised as the coastal plain tilted in response to down-warping of the crustal floor of the Gulf of Mexico, the result of the deposition of voluminous deltaic sediment ever farther into the Gulf through time (Louisiana Geological Survey 2011).

The processes that created the fluvial and deltaic sedimentary sequences that comprise the majority of the surface strata in Louisiana persist to the present time. Every several hundred years the lower Mississippi River has abandoned its course to form a new lobe of deltaic sediment. This occurs when the old river course has become longer and higher, and has a lower gradient or slope, than an alternative course because of the build-up of sediment deposited by the river and the subsidence of older lobes and adjacent areas (Aronow and Heinrich 2004).

West Coastal Plain along the North Gulf Coast of Texas

The West Coastal Plain along the North Gulf Coast of Texas is characterized by nearly flat grasslands formed on Pleistocene- and Holocene-age deltaic sands, silts, and clays (Bureau of Economic Geology 1996). The smooth, low-lying land surface slopes gently to the Gulf of Mexico. The Coastal Plain of Texas is dissected by numerous rivers, including the Brazos River near the project area. Most of the major rivers have broad alluvial valleys and deltaic plains and empty sediment loads directly into the Gulf of Mexico, whereas smaller rivers have narrow valleys and drain into estuaries or lagoons that are disconnected from the Gulf by onshore barrier islands or offshore bars. Differential erosion of softer and harder beds between the river valleys led to the formation of parallel low ridges and escarpments. Like the Coastal Plain of Louisiana, the Coastal Plain of Texas is underlain by a massive thickness of sediments that slope towards the Gulf of Mexico.

3.3.2 Stratigraphy and Structure

The subsurface stratigraphy and structure of the Louisiana and Texas coasts are the result of the deposition of massive amounts of sediment into the Gulf Coast Basin. The Gulf Coast Basin is characterized by numerous growth faults. A growth fault is a type of fault on which there were displacements at the same time as the sediments on either side of the fault were accumulating. Most growth faults are normal faults because such faults cause the basins in which sediments are deposited to subside. A growth fault is characterized by preserving greater vertical thicknesses of sedimentary horizons on the side of the fault that has been thrown down (Hancock and Skinner 2000). Growth faults in the Gulf Basin may develop from the buoyant rise of salt or shale, differential sediment loading, differential compaction, and free gravity sliding. Movement caused by the faulting may break the hydraulic conductivity of strata and produce barriers to fluid flow or conduits for cross-formational flow (Baker 1979).

Southwest Louisiana

The stratigraphic sequence in southwest Louisiana consists of unconsolidated deltaic and near-shore marine sediments. These sediments are characterized by clays and silty clays intersected by layers and lenses of silt and sand, and gravels. Figure 3.3-2 provides a listing of stratigraphic and hydrostratigraphic units of southwestern Louisiana.

Texas Coastal Plain

The stratigraphy and structure of the Hastings oil field is similar to that of the remainder of the southeastern Texas Coastal Plain in that it consists of a thick sequence of sedimentary strata that has been separated by faulting. Figure 3.3-3 provides a listing of stratigraphic and hydrostratigraphic units of southeastern Texas.

In the Hastings oil field, movement along the faults has created a barrier to subsurface fluid flow and subsequent accumulation of petroleum hydrocarbons. Such reservoirs, called stratigraphic traps, have the ability to store petroleum hydrocarbons for millions of years and are related to deep-seated salt formations. The West Hastings oil field consists of several isolated fault blocks where commercial EOR operations are being conducted or scheduled to be conducted. The Frio Formation in Fault Blocks B and C is the target reservoir for the proposed CO₂ sequestration in commercial EOR operations and research MVA activities.

The research MVA program will demonstrate the storage of CO₂ in the Frio Formation, which is approximately 6,600 feet below ground surface (bgs).

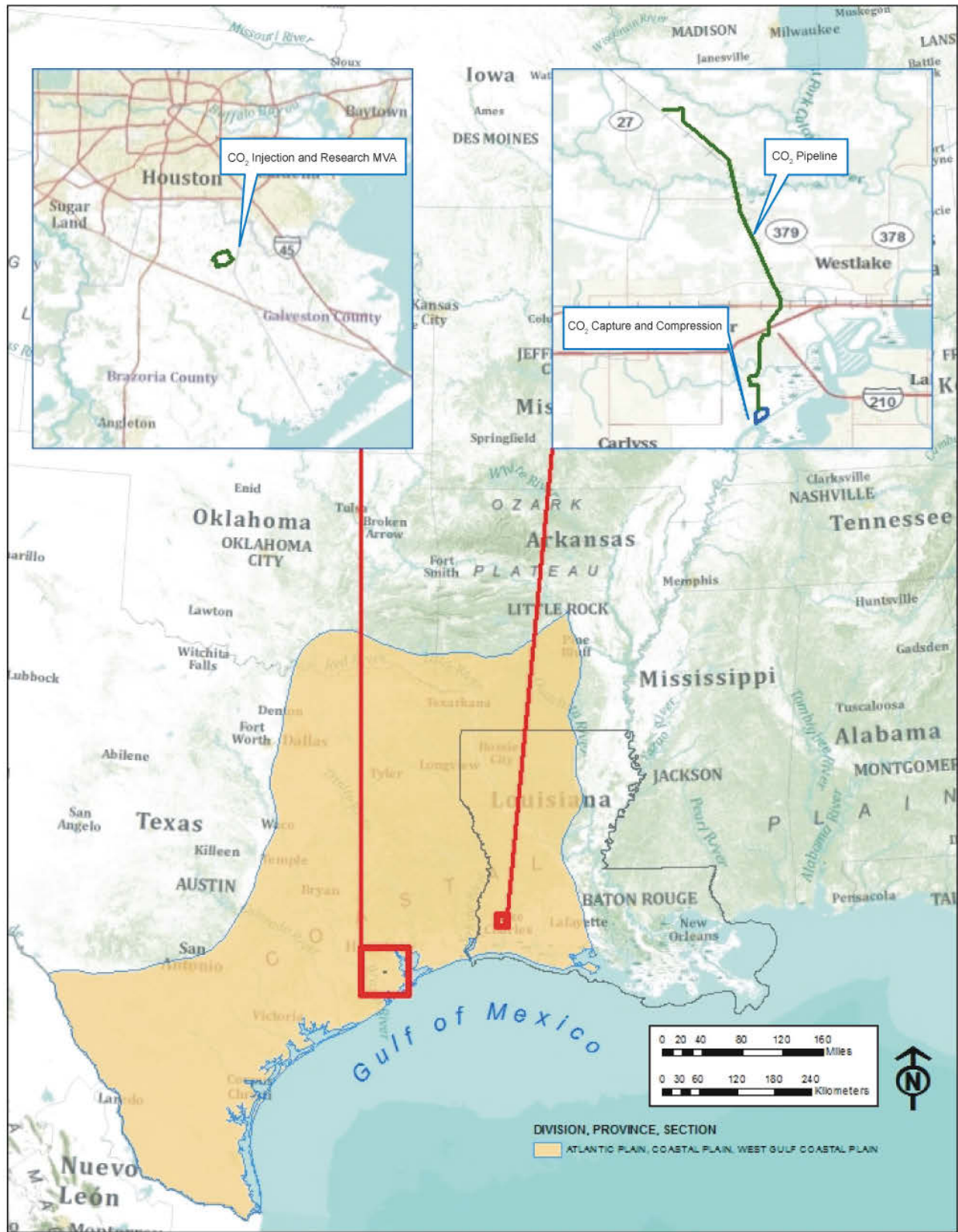

Figure 3.3-1
Regional Physiography for the
Lake Charles CCS Project (Proposed Project) and
LCCE Gasification Project (Connected Action)

System	Series	Stratigraphic Unit		Hydrostratigraphy		
				Southwestern Louisiana aquifer or confining unit		
Quaternary	Holocene	Alluvium		Shallow sand or surficial confining unit		
	Pleistocene	Unnamed Pleistocene deposits		Chicot aquifer system	"200-foot" sand Upper sand unit	
					"500-foot" sand "700-foot" sand Lower sand unit	
Tertiary	Pliocene	Blounts Creek Member		Evangeline aquifer		
	Miocene	Castor Creek Member		Castor Creek confining unit		
		Fleming Formation	Williamson Creek Member		Williamson Creek aquifer Dough Hills confining unit Carnahan Bayou aquifer	
			Dough Hills Member			
			Carnahan Bayou Member			
			Lena Member			
Oligocene	Catahoula Formation		Catahoula aquifer			

Figure 3.3-2
Stratigraphic and Hydrostratigraphic Units in Southwestern Louisiana
(modified from LGS 2000)

System	Series	Stratigraphic Units		Hydrostratigraphy
				Baker (1979)
Quaternary	Holocene	Alluvium		Chicot aquifer
	Pleistocene	Beaumont Clay		
		Lissie Formation	Montgomery Formation	
			Bentley Formation	
		Willis Sand		
Tertiary	Pliocene	Goliad Sand		Evangeline aquifer
	Miocene	Fleming Formation/ Lagarto Clay		Burkeville Confining System
		Oakville Sandstone		Jasper aquifer
		Oligocene	1 Catahoula tuff or sandstone	2 Upper part of Catahoula tuff
			2 Anahuac Formation	
			2 Frio Formation	
1 Frio Clay	2 Vicksburg Group equivalent			

1 = outcrop
2 = subsurface

SOURCE: Chowdhury and Turco, 2006

Figure 3.3-3
Stratigraphic and Hydrostratigraphic Units in the Gulf Coast Basin in Texas

Multiple sandstones within the Oligocene-age Frio Formation are productive within the West Hastings oil field and would be the target formation for CO₂ injection. Two sandstones of the upper Frio Formation were previously tested and found favorable for monitoring and for sequestration by the Texas Bureau of Economic Geology's Frio brine pilot test, east of Houston, Texas. The Frio Formation underlying the West Hastings oil field is composed of a number of sandstones separated by shales. The sandstones in the Frio Formation underlying the West Hastings Field are typical of most sandstones along the Texas and Louisiana Gulf Coast, where porosities are in the 28% to 32% range and permeabilities are high, in the 200 to 2,000 millidarcy (md) range (AIPC 2011).

Figure 3.3-4 shows a 120-mile-long geologic cross-section that extends from the Gulf of Mexico through Grimes, Montgomery, Harris, and Galveston counties. The proposed project is located approximately 2 to 3 miles west of Well No. 9 on the cross-section in northeast Brazoria County and is representative of the project area. The Frio Formation consists of interbedded sandy clays, sands, and sandstone (Chowdhury and Turco 2006) and ranges in thickness from approximately 250 to 600 feet in the subsurface. As shown in Figure 3.3-4, the top of the Frio Formation is approximately 6,600 feet below ground surface near the project area. Underlying the Frio Formation is the Vicksburg Group, which is a regionally confining unit consisting primarily of marine clays and thinly bedded sandstones. More importantly, the Anahuac Formation overlays the Frio Formation and serves as a stratigraphic seal and prevents the upward migration of hydrocarbons or other fluids. It is this sequence of stratigraphy that allows the Frio Formation to serve as a reservoir for petroleum hydrocarbons.

The Anahuac Formation is a regionally extensive mudstone that is approximately 900 feet thick near the project area, extending from approximately 5,700 to 6,600 feet below ground surface (bgs) (see Figure 3.3-4). The Anahuac Formation also serves as the confining layer (or seal) for existing injection disposal wells in the region. The seal properties of the Anahuac Formation were studied as part of the Frio Brine pilot study near Dayton, Texas which demonstrated that this formation serves as an excellent seal (AIPC 2011). The Catahoula Sandstone overlays the Anahuac Formation to a depth of approximately 4,800 feet bgs. The Fleming Formation overlays the Catahoula Sandstone to a depth of approximately 700 feet bgs. Occurring within the Fleming Formation is the Chicot-Evangeline aquifer, which is underlain by the Burkeville Confining System and the Jasper aquifer. The water quality in the upper portions of the Chicot-Evangeline aquifer qualifies it as an Underground Source of Drinking Water (USDW). However, because the concentration of total dissolved solids (TDS) in the Jasper aquifer exceeds 10,000 milligrams per liter (mg/L), it is not considered an USDW (LBG-Guyton Associates 2003). The Burkeville Confining System separates these two aquifers and contains a large percentage of silt and clay and is approximately 700 feet thick near the project area. The Burkeville Confining System also serves as a secondary confining unit to the Anahuac Formation.

3.3.3 Mineral Resources

Calcasieu Parish, Louisiana

Louisiana's mineral resources that are currently recovered or potentially recoverable near the proposed project include oil, gas, coal, salt, sand and gravel, gypsum, lime, and stone. Southern Louisiana is an active area for oil and gas production. The Louisiana Oil Spill Coordinator's

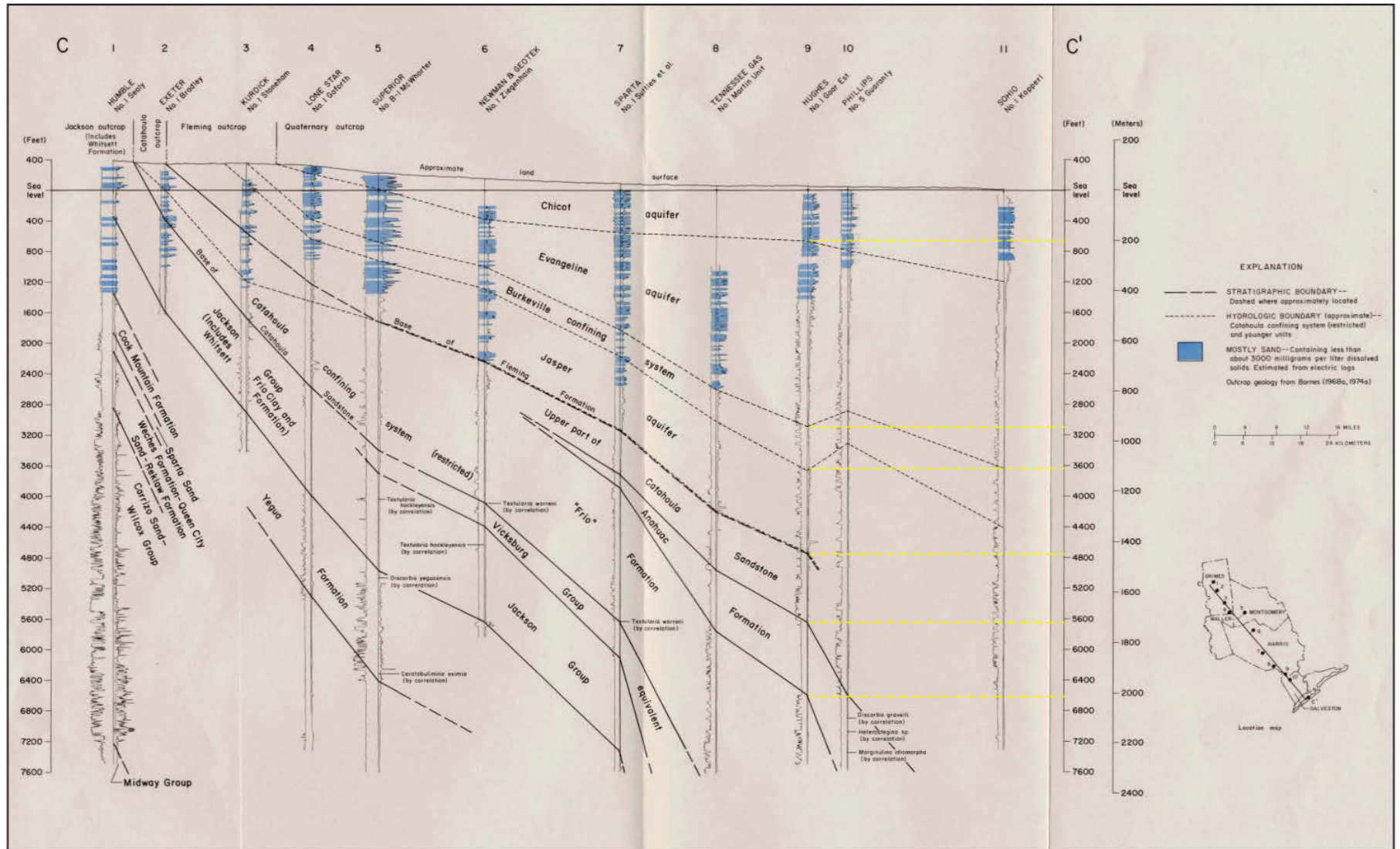

SOURCE: Baker, 1979

Figure 3.3-4
Cross-Section C-C' in the Gulf Coast Basin in Texas

Office (LAOSCO) database identifies oil and gas wells near the proposed project in Calcasieu Parish.

The closest major salt mine, Texas Brine Corp., is in northern Jefferson County, Texas. Sand and gravel operations are present in Calcasieu Parish, Louisiana.

Hastings Oil Field, Texas

The Hastings oil field is classified as a Frio Deep-Seated Salt Dome field. The Frio Deep-Seated Salt Dome fields occur south and southeast of Houston in Brazoria, Fort Bend, Harris, Galveston, and Chambers counties along the Texas coast. Located on domal structures, the fields are divided into small segments by closely spaced faults that block fluid communications in the subsurface.

The Hastings oil field, as described above, is compartmentalized into a set of contiguous, large-scale, fault-segregated geologic blocks. A subsurface fault exists within the Hastings oil field area, trending northwest-southeast along a line that approximately follows Texas Highway 35 between Pearland and Alvin. In 1958, the trace of this fault was selected as a line dividing the West Hastings and East Hastings oil fields. A series of cross faults further compartmentalize the West Hastings oil field into geologic areas (i.e., blocks) (AIPC2011).

3.3.4 Seismology

The magnitude of an earthquake is reported on the Richter scale and is a measurement of the amount of energy released at the source of a quake. This data is gathered on seismographic recordings from a worldwide network of seismological stations. A minor earthquake registering a magnitude 2 on the Richter scale is about the weakest felt by humans.

Although there are numerous faults in the Gulf Coast Basin, they are generally decoupled from the underlying crust, which reduces the likelihood that the faults can generate significant seismic ruptures that can cause damaging ground motion. The U.S. Geological Survey (USGS) National Seismic Hazard Map of 2008 indicates that southwestern Louisiana and the Texas Gulf Coast are in seismically stable areas (USGS 2011). Figure 3.3-5 shows that the project area in Louisiana has a 2% probability of exceeding a peak horizontal acceleration (PHA) of 4% to 6% of gravity in 50 years, and that the project area in Texas has a 2% probability of exceeding a peak horizontal acceleration of 2% to 4% of gravity in 50 years. PHA represents the maximum acceleration observed during shaking and is used for engineering design. (For context, buildings that are not earthquake-resistant undergo structural damage when the peak ground acceleration exceeds 10% g.) The risk of a seismic event occurring within the proposed MVA project area is therefore very low. The largest earthquake known to have occurred in Texas was a magnitude 5.80 earthquake, which occurred in 1931 near Valentine, Texas, over 600 miles west of the Hastings oil field (AIPC 2011).

3.3.5 Soil Classification and Description

Calcasieu Parish, Louisiana

The *Soil Survey of Calcasieu Parish, Louisiana* (Roy and Midkiff 1988) delineates and describes soils in the project areas in Louisiana. Figure 3.3-6 shows the LCCE Gasification plant and Lake Charles CO₂ Capture and Compression facilities on the delineated soil boundaries. The project

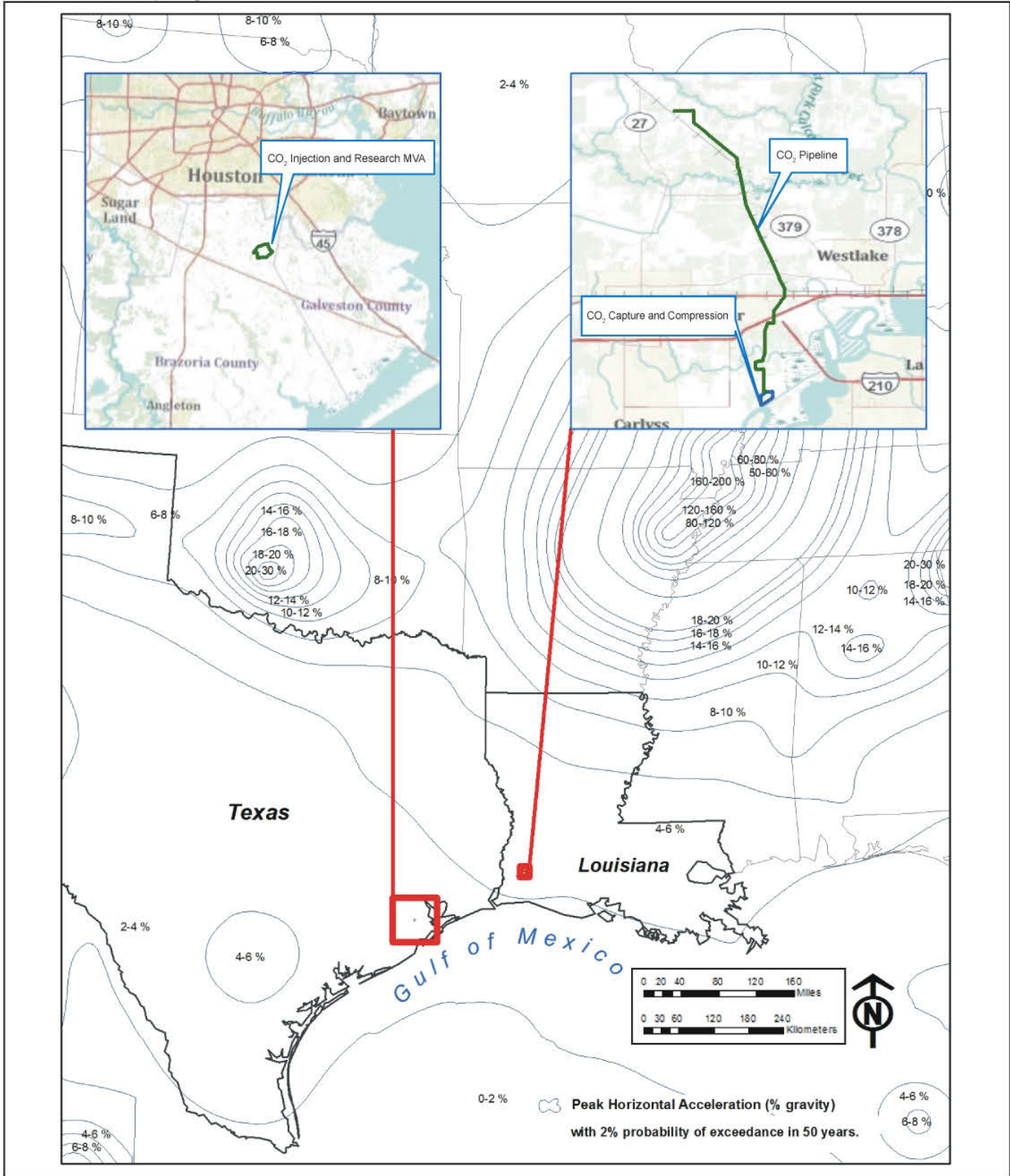

SOURCE: U.S. Geological Survey Earthquake Hazards Program

Figure 3.3-5
Seismic Hazard Map for the
Lake Charles CCS Project (Proposed Project) and
LCCE Gasification Project (Connected Action)

components are underlain by four silt loam soil series: Acadia silt loam (Ac), Basile and Guyton silt loams (BB), Kinder-Messer silt loams (Kd), and Mowata-Vidrine silt loams (Mt).

Figure 3.3-7 shows the proposed CO₂ pipeline route superimposed on the delineated soil boundaries. Table 3.3-1 lists the soil series that will be encountered by the proposed CO₂ pipeline in Calcasieu Parish. In addition to Ac, BB, Kd, and Mt soil types, the pipeline project components are also underlain by Arat mucky silt loam (AR), Brimstone silt loam (Bo), Clovelly muck (CO), Dumps (Dm), Guyton silt loam (Go), Guyton-Messer silt loams (GY), and Leton silt loam (Lt). Table 3.3-1 summarizes the characteristics of the soils potentially encountered in Calcasieu Parish.

Table 3.3-1 Soil Series for Project Areas in Calcasieu Parish, Louisiana

Soil Series	Map Unit Symbol	Hydric Soil	Slope	Hazard of Erosion	Prime Farmlands ¹
Acadia silt loam	Ac	N	1-3%	Slight	Yes
Arat mucky silt loam	AR	Y	0-1%	Slight	No
Basile and Guyton silt loams, frequently flooded	BB	Y	0-1%	Slight	No
Brimstone silt loam	Bo	Y	0-1%	Slight	No
Clovelly muck	CO	Y	0%	Very Severe	No
Dumps	Dm	-	-	-	No
Guyton silt loam, occasionally flooded	Go	Y	0-1%	Slight	No
Guyton-Messer silt loams	Gy	Y	0-1%/1-5%	Slight/Mod	Yes
Kinder-Messer silt loams	Kd	Y	0-1%/1-5%	Slight/Mod	Yes
Leton silt loam	Lt	Y	0-1%	Slight	Yes
Mowata-Vidrine silt loams	Mt	Y	0-1%	Slight	Yes

Key:

¹ As rated by the USDA Natural Resource Conservation Service.

Hastings Oil Field, Texas

The *Soil Survey of Brazoria County, Texas* (Crenwelge et al. 1981) delineates and describes soils in the project area in Texas. Figure 3.3-8 shows the West Hastings research MVA area on the delineated soil boundaries. The project components are underlain by three soil types: the Bernard clay loam, Bernard-Edna complex, and Lake Charles clay. Table 3.3-2 summarizes the characteristics of the soils potentially encountered in the project area in the Hastings oil field.

Table 3.3-2 Soil Series for Project Areas in Hastings Oil Field, Texas

Soil Series	Map Unit	Hydric Soil	Slope	Hazard of Erosion	Prime Farmland ¹
Bernard clay loam	7	Yes (2B3)	0-5%	Slight	Yes
Bernard-Edna complex	8	Yes (2B3)	0-5%	slight	Yes
Lake Charles clay	24	Yes (2B3)	0-1%	slight	Yes

Key:

¹ As rated by the USDA Natural Resource Conservation Service.

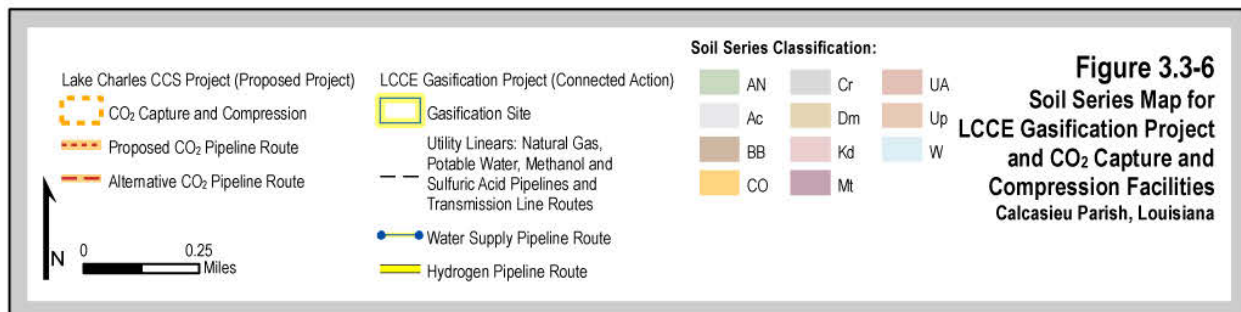
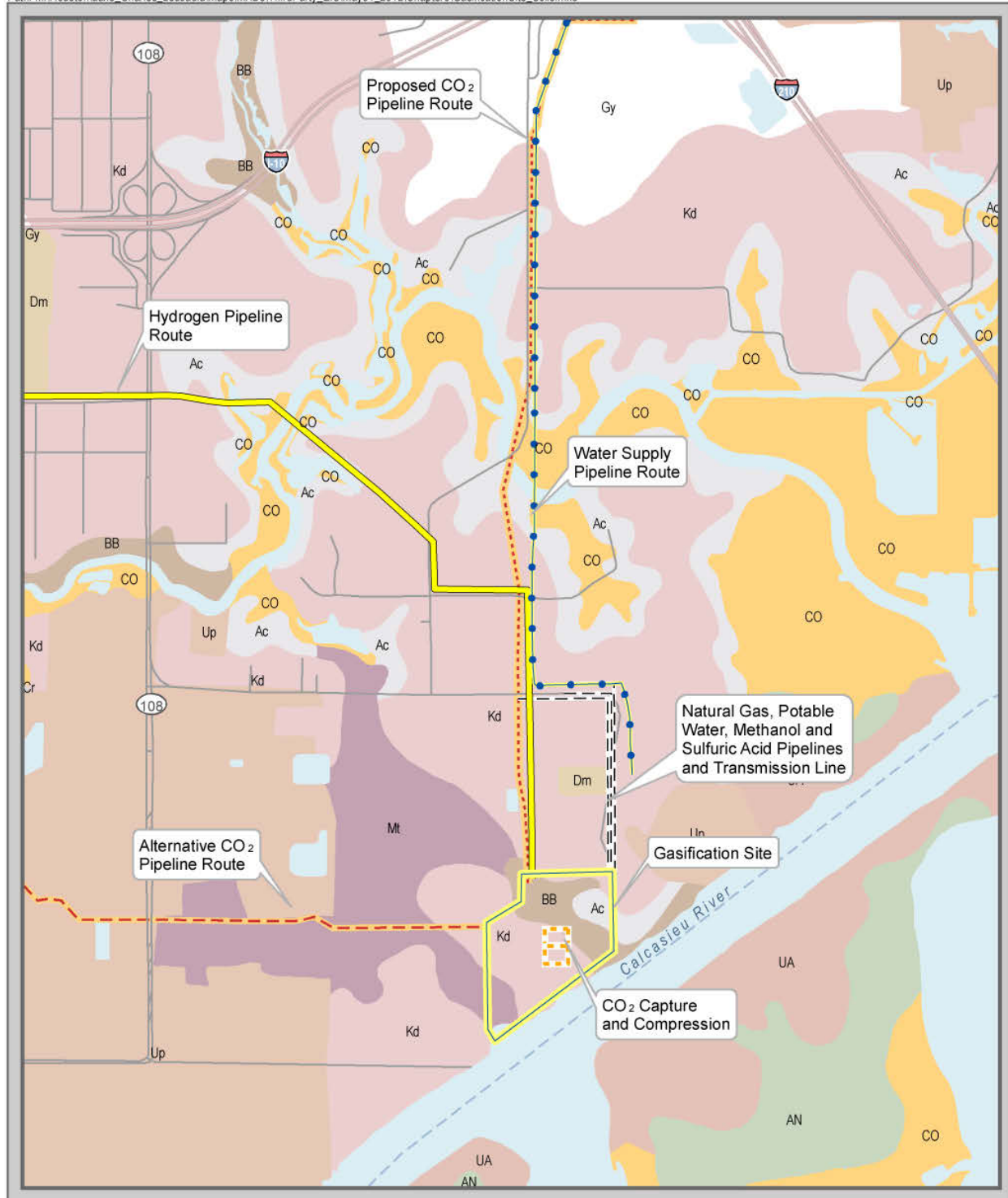

Source: USDA NRCS 2011.

This page left blank intentionally.

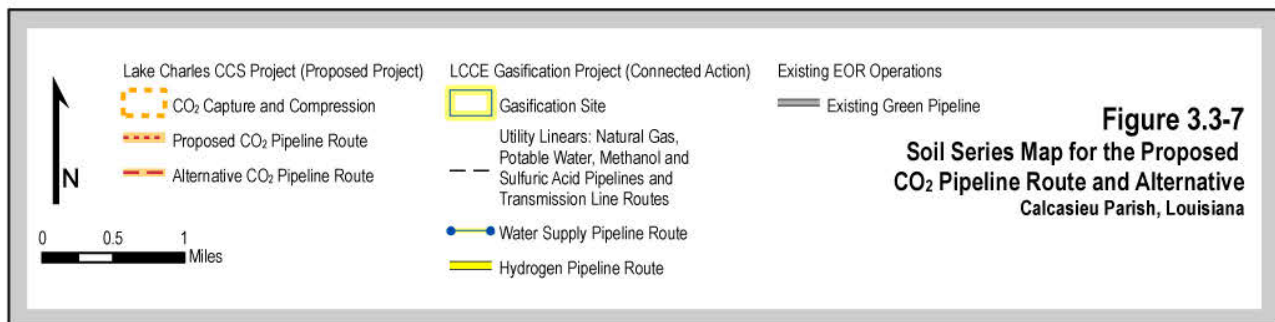
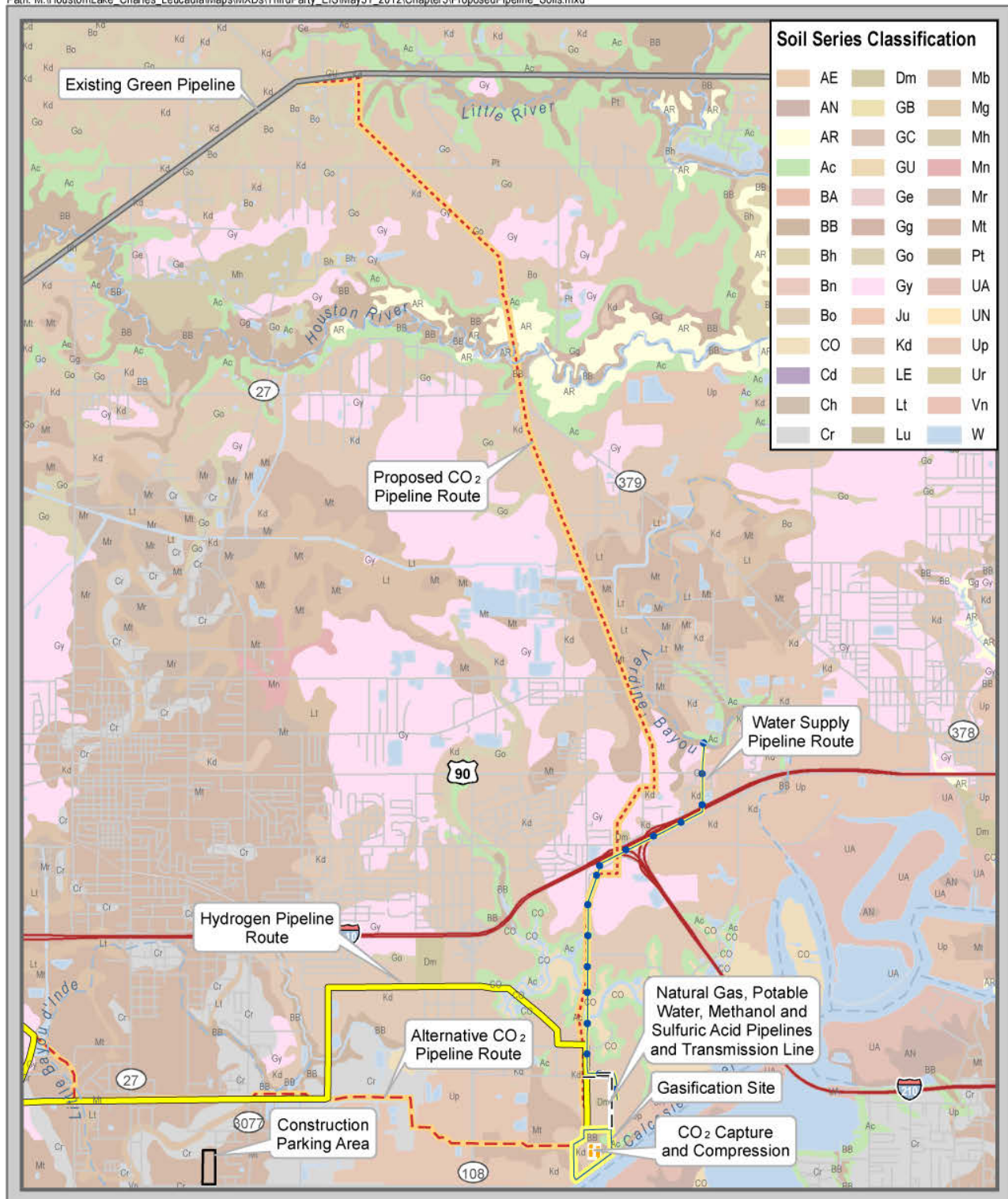

Figure 3.3-7
Soil Series Map for the Proposed
CO₂ Pipeline Route and Alternative
Calcasieu Parish, Louisiana

This page left blank intentionally.

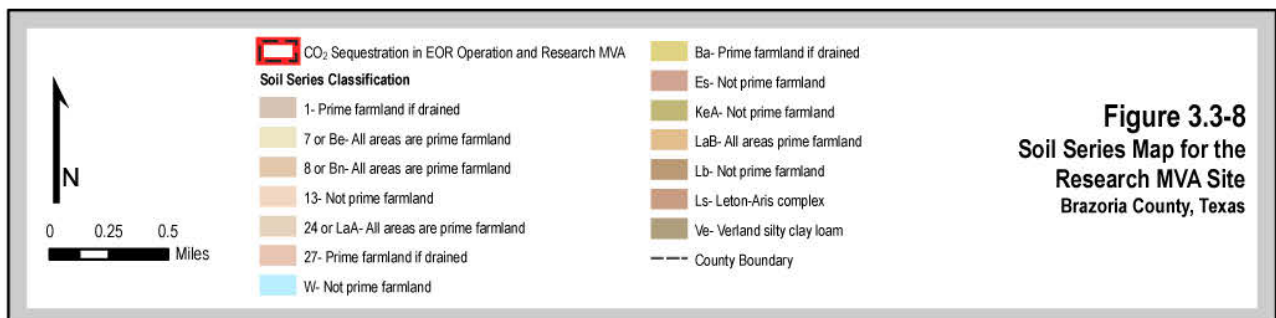
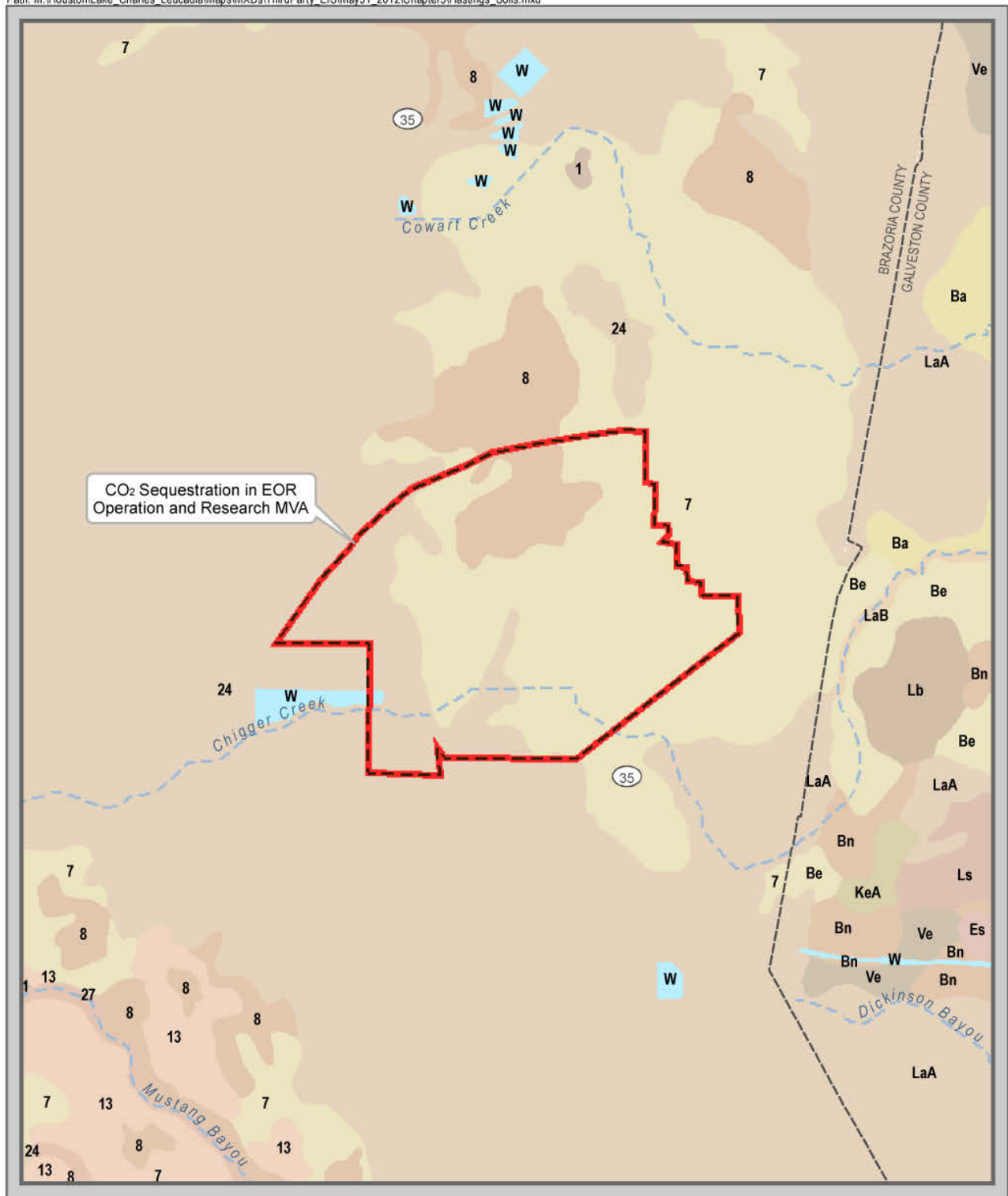

Figure 3.3-8
Soil Series Map for the
Research MVA Site
Brazoria County, Texas

This page left blank intentionally.

3.3.6 Prime Farmland and Other Important Farmlands

Calcasieu Parish, Louisiana

Roy and Midkiff (1988) identify soil types in Calcasieu Parish that meet the requirements for prime farmland except where the use is urban or built-up land. As shown on Figures 3.3-7 and 3.3-8, the proposed CO₂ pipeline passes through rural areas between the alluvial soils, which may be regarded as prime farmland. Table 3.3-1 identifies the soils meeting the requirements as prime farmland.

Hastings Oil Field, Texas

As identified in Table 3.3-2, the Bernard clay loam, Bernard-Edna complex, and Lake Charles clay soil types meet the requirements of prime farmland. However, although the soils are classified as prime farmland soil, they do not have the potential to support agriculture because of the existing oil field.

3.4 Surface Water

3.4.1 Regional Hydrology

The LCCE Gasification plant and the Lake Charles CCS CO₂ Capture and Compression facilities and CO₂ Pipeline are located in the Calcasieu River estuary and watershed in southwestern Louisiana; the West Hastings research MVA site is located in the watersheds of Chigger Creek and Cowart Creek in southeastern Texas.

Calcasieu River Watershed

The Calcasieu Estuary is a hydrological system where freshwater and saltwater mix and is comprised of the lower reach of the Calcasieu River as it enters the coastal plain; a series of low-lying, semi-inundated marsh areas interspersed with open-water lakes; and bayous that drain to the lower portions of the Calcasieu River watershed and estuary. Many open-water bodies of this estuary, such as Moss Lake, Prien Lake, and Lake Charles, were once freshwater but have become more saline due to numerous factors, including human alterations of the local hydrology. NOAA maintains a Calcasieu Estuary Watershed Database and Mapping Project for this area (NOAA 2011) and divided the estuary into four major areas: Bayou Verdine, Bayou d'Inde, the Upper Calcasieu River, and the Lower Calcasieu River.

The Calcasieu River drains southwestern Louisiana into the Calcasieu Lake and Estuary, and ultimately into the Gulf of Mexico. The Calcasieu River, which is approximately 200 miles in length, drains a 3,500-square-mile watershed within the larger Gulf of Mexico coastal plain shown in Figure 3.4-1. The proposed project would be located approximately in the middle of this watershed, about 29 miles inland from the Gulf.

Figure 3.4-2 shows key waterbodies in the vicinity of the project. The Calcasieu River consists of numerous meanders and a series of large, open-water lakes. The river is typified as a low-gradient stream, and flow volumes north of the project are reported to be 92 cubic feet per second (cfs) (USGS 2011). The river flows through a floodplain characterized by marshes and swamps; the floodplain is approximately 4 miles wide near the proposed site. Prien Lake is to the east. Portions of the Calcasieu River have been modified by the U.S. Army Corps of Engineers (USACE) to provide a deep-draft navigation channel around Prien Lake (USACE 1998). Known as the Calcasieu Ship Channel, this navigation channel extends from the Gulf, through Calcasieu Lake, and includes the river segment adjacent to the proposed LCCE

Gasification plant and Lake Charles CCS CO₂ Capture and Compression facilities site. The speed of the river's current at this location is below 0.1 m/s (USACE 2009). The Houston River, which is a smaller tributary of the Calcasieu River, flows west to east to the north of the site. The Houston River flows into the Calcasieu River at the city of Lake Charles, Louisiana. The Houston River watershed is 154 square miles in area within the Calcasieu River Watershed Basin.

Bayou Verdine, a small tributary of the Calcasieu River, flows into the upper Calcasieu Estuary. It originates in an agricultural area and then flows through both residential and industrial areas before joining the river at the Coon Island Loop.

Bayou d'Inde, a 9-mile-long, narrow, sinuous channel, occupies approximately 1,486 acres and is characterized by expanses of marsh and bald cypress swamp. This bayou is located southwest of Lake Charles, south of the Houston River, and approximately 1.3 miles north of the site. Bayou d'Inde drains through the city of Sulphur, Louisiana, before joining the Calcasieu River.

In the Calcasieu Estuary, fresh river water and saltwater from the Gulf of Mexico mix daily. The daily tides for this riverine-estuarine system have both diurnal and semidiurnal components but are primarily diurnal, resulting in a single high tide and single low tide per day. Spring tides vary by approximately 1.9 feet according to the USACE's Coastal Inlets Research Program and NOAA (NOAA 2011). Extreme changes in water levels sometimes occur as a result of storm surges from tropical systems and the passage of winter weather fronts. In addition, water levels are elevated above normal by surface runoff during intense rainfall events. See the floodplain discussion in Section 3.4.4 for further information on water levels.

The average monthly precipitation for southwestern Louisiana ranges from 3.5 to 6.1 inches, with an average annual total precipitation of 57 inches. Local surface drainage patterns have been altered over time by the straightened configuration of the Calcasieu Ship Channel and incremental area development associated with surrounding roads and industrial land uses. Surface flow from the LCCE Gasification plant and Lake Charles CCS project site has been diverted to either the drainage easement on the north or to a perimeter drainage conveyance system on the west side. Both drainage systems discharge storm water into the Calcasieu Ship Channel.

Water supply would be obtained from the Sabine River Diversion (SRD) System, which is operated by the Sabine River Authority in Louisiana. The SRD System was created in 1970 as part of a program to use impounded waters from the Toledo Bend Reservoir to deliver fresh raw water from the Sabine River to various industries located in the Lake Charles industrial area, for municipal water use, and for farm irrigation along the diversion route. The system consists of 35.2 miles of unlined, open channel canals; 4.42 miles of underground, cement-coated steel pipelines; five constant-level downstream control gates; and three pumping stations.

The SRD system operates automatically. As water is removed from the lower reaches of the system, the constant-level downstream control gates open and Pump Station 1 is activated to release water from the upper reaches of the Old River to replenish water in the downstream portion of the system. The system has been highly successful in slowing the depletion of groundwater reserves in the Chicot aquifer by continued growth of industry, agriculture, and municipal use in southwestern Louisiana. In recent years, nearly 20 billion gallons of diverted

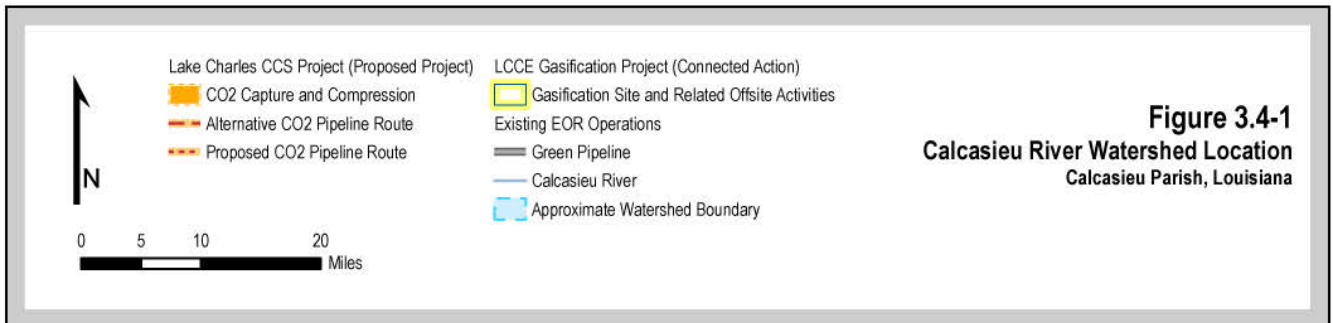
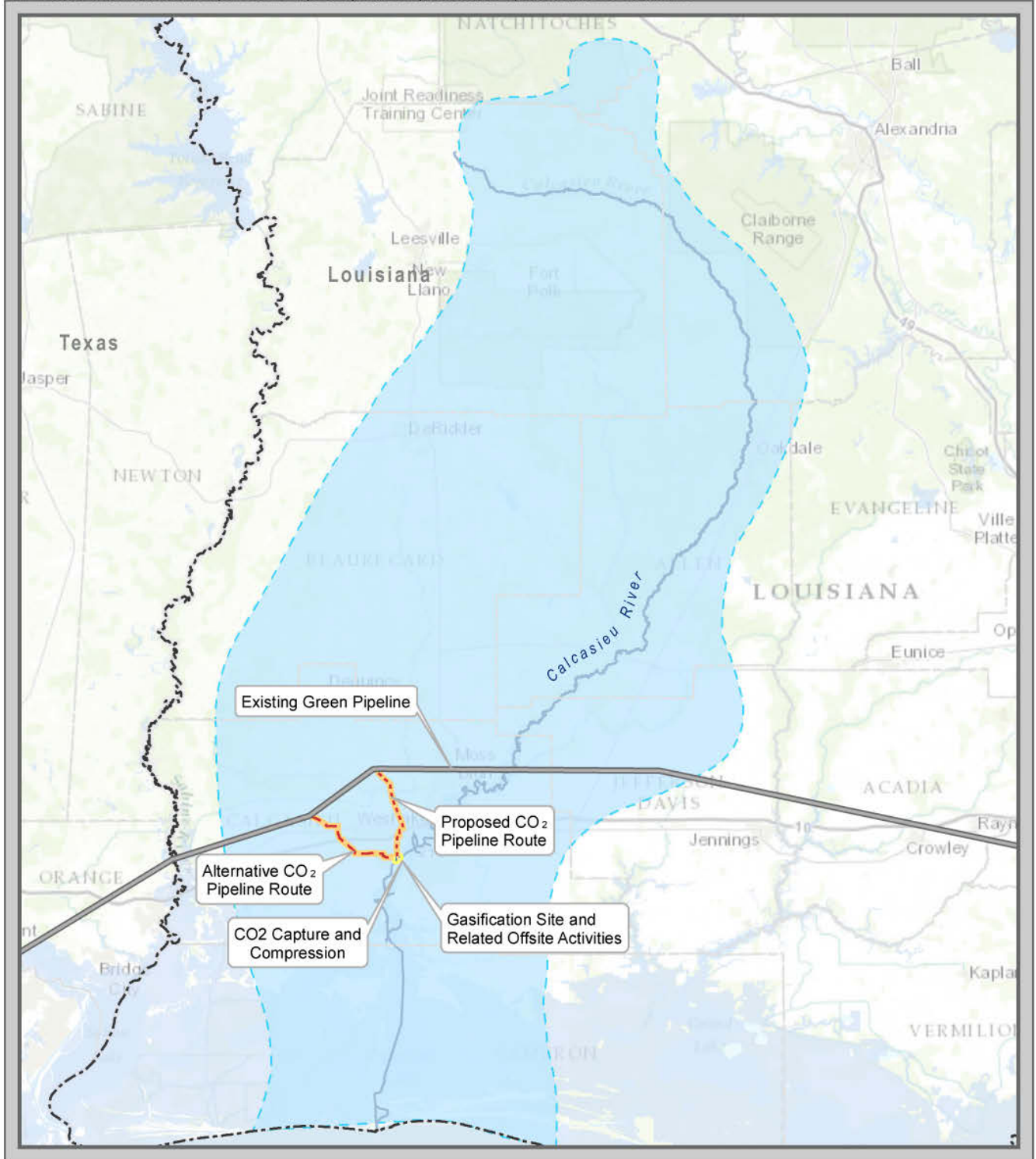

Figure 3.4-1
Calcasieu River Watershed Location
 Calcasieu Parish, Louisiana

This page left blank intentionally.

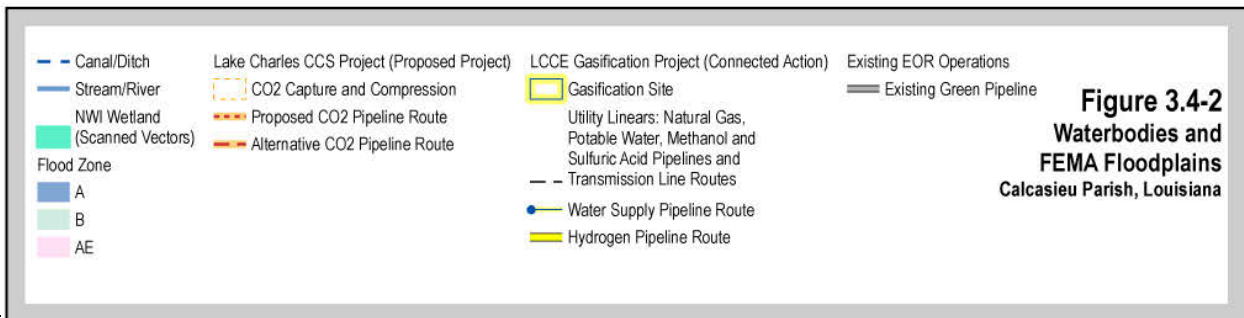
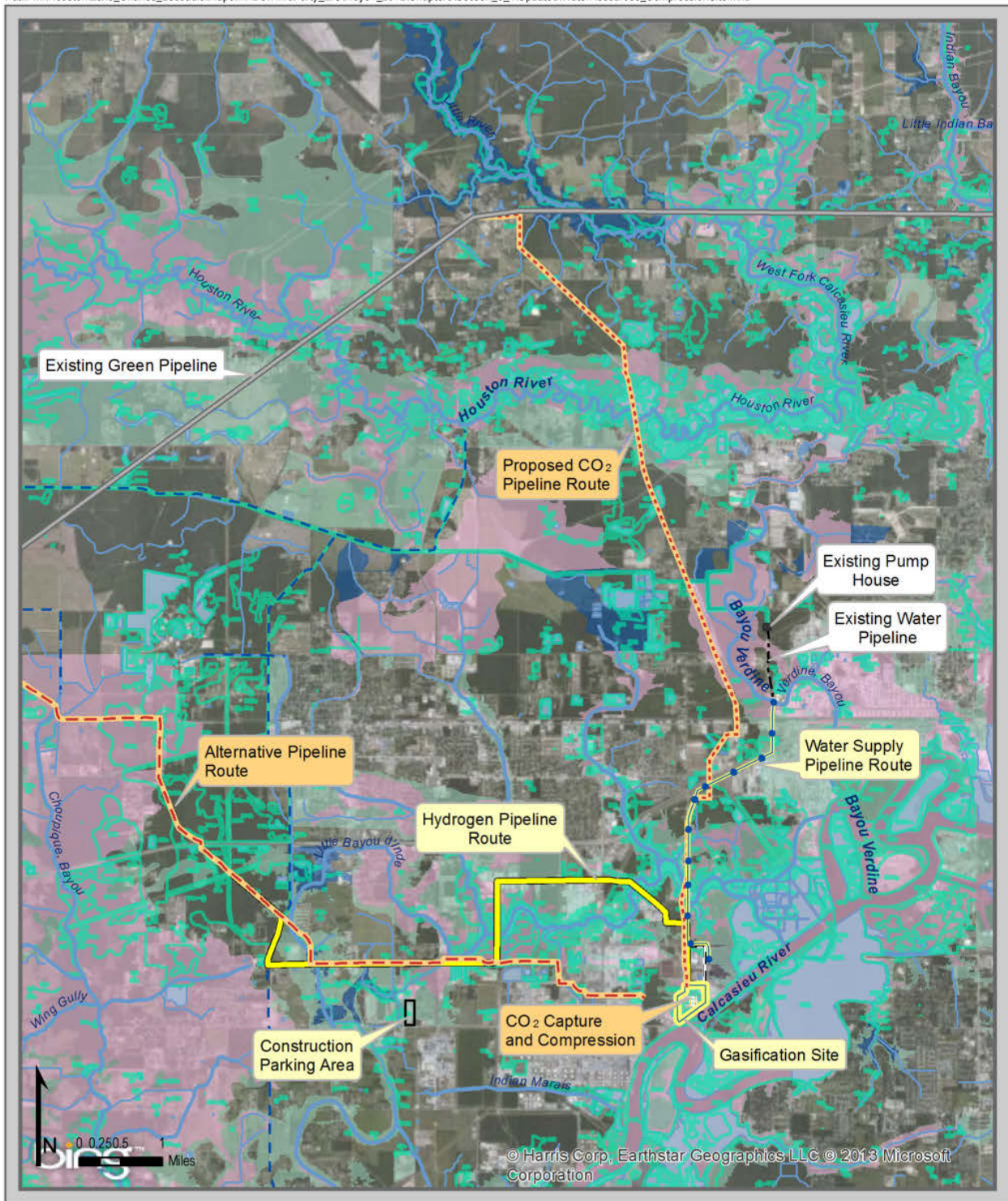

Figure 3.4-2
Waterbodies and
FEMA Floodplains
Calcasieu Parish, Louisiana

This page left blank intentionally.

water has been pumped through the SRD System each year, primarily for industrial use (SRA 2011).

CO₂ Pipeline Route

The proposed Lake Charles CCS Project CO₂ pipeline route is also located within the Calcasieu River watershed (see Figure 3.4-1). The surface water resources along the proposed route include Bayou d'Inde, the Houston River, the SRD System Canal, and four perennial waterbodies and their associated marshes. The proposed CO₂ pipeline route shares the same regional and project area hydrologic setting as described above.

Hastings Oil Field, Texas

The hydrologic setting of the Hastings oil field is the Texas gulf coastal plain and is influenced by its location in Brazoria County, Texas. The Gulf Coast is a nearly level, slowly drained plain. It is dissected by rivers and streams flowing into the Gulf of Mexico. The hydrologic setting in this area is influenced not by rivers but rather by direct precipitation, which annually averages approximately 30 to 60 inches, and surface runoff. Project area surface water features include Cowart Creek, which drains to the northeast from the Hastings oil field, and Chigger Creek, which drains to the southeast, with rectified drainage tributaries from the Hastings oil field area draining into each of these creeks (Coenco 1985). Cowart Creek and Chigger Creek together drain approximately 20,300 acres, which includes the Hastings oil field (Coenco 1985). Chigger Creek and Cowart Creek both flow into Clear Creek, a major tributary of Clear Lake and Galveston Bay along the Gulf of Mexico. Other hydrologic features of the project area are scattered, unnamed waterbodies, which are man-made stock tanks/ponds (see Figure 3.4-3).

3.4.2 Surface Water Quality and Use

Section 303(d) of the CWA requires states to identify and develop a list of impaired waterbodies. Impaired waterbodies are those that do not meet the water quality standards or designated uses set by the state. Section 305(b) of the CWA requires states to assess and report the quality of their waterbodies. The Section 305(b) Water Quality Report (LDEQ 2011) prepared by the LDEQ summarizes the monitoring data that characterizes the quality of waters in the Calcasieu River and Ship Channel (Water body LA-030301), the Houston River (Waterbody LA-030806), Bayou Verdine (Waterbody LA-030306), and Bayou d'Inde (Waterbody LA-030901), among other waters in the state. The designations for water quality and use for the relevant surface waters are summarized in Table 3.4-1. Surface water for industrial and public uses is described below.

Calcasieu River Watershed, Louisiana

Surface water quality in the project area is influenced by the surrounding industrial land uses. Storm water is discharged from the local surrounding industries, including the CITGO Tank Farm to the south. Discharges from the Basell Company, Louisiana Pigment Company, and City of Sulphur Wastewater Treatment facility had historically flowed to constructed ditches and through a natural drainage on the eastern portion of the site, or along a constructed drainage on the western boundary of the LCCE Gasification plant site (URS 2007; USACE 1998, 2009). Several shallow drainage ditches were located on this 70-acre site and provided for permitted discharges from three industrial facilities to the natural drainage on the site and then to the Calcasieu River and Ship Channel (LDEQ 2010).

Several segments of the Calcasieu River were placed on the Louisiana 2004 Section 303(d) list of waterbodies that are monitored for elevated levels of mercury, copper, polychlorinated biphenyls (PCBs), and polycyclic aromatic hydrocarbons (PAHs) (USACE 2009). These impairments, along with elevated levels of fecal coliform bacteria and low dissolved oxygen (DO), typically affect water use designations. The seven designated water uses for Louisiana waters are: Primary Contact Recreation, Secondary Contact Recreation, Fish and Wildlife Propagation, Drinking Water Supply, Oyster Propagation, Agriculture, and Outstanding Natural Resource Waters. The LDEQ sets Total Maximum Daily Loads (TMDLs) and regulates discharges of these contaminants through permits. The TMDL reflects the pollutant loading that a waterbody can assimilate without exceeding the water quality standard for that pollutant. Table 3.4-1 lists the parameters for which LDEQ set TMDLs. Each permit issued by the LDEQ reflects an evaluation of the cumulative contribution of contaminants compliance with applicable water quality standards.

Table 3.4-1 Surface Water Quality and Use Designation

Surface Waterbody	Water Quality Segment	303(d) list	Use Designation	Pollutants with TMDLs
Calcasieu River Estuary and Ship Channel (to Moss Lake)	La-30301	Yes	Partially meeting	Metals: copper and mercury Priority Organics Ammonia
Calcasieu River Estuary and Ship Channel (below Moss Lake)	La-030401	No		None
Houston River	La-030806	No	Partially meeting - Not supporting fish and wildlife propagation	Organic enrichment/ low DO, pH, salinity/TDS/chlorides, and sulfates.
Bayou d'Inde	La-030901	Yes	Not meeting	Priority organics: hexachlorobutadiene, PCBs, bromoform, tetrachloroethane, and hexachlorobenzene Metals: copper, nickel Non-Priority Organics Other Inorganics
Bayou Verdine	La-030306	Yes	Not meeting	Priority organics, including total phenols and ethylene dichloride Non-Priority Organics Metals: copper, mercury, and nickel

Source: LDEQ 2011.

The NOAA, on behalf of the USFWS, LDEQ, and Louisiana Department of Wildlife and Fisheries (LDWF), assessed hazardous substances present in sediments in Bayou Verdine and Coon Island Loop. The assessment identified damages and restoration requirements for this bayou (NOAA 2012a). The sediment contamination included heavy metals, PAHs, and volatile organic compounds (VOCs). These contaminants impacted primarily benthic resources,

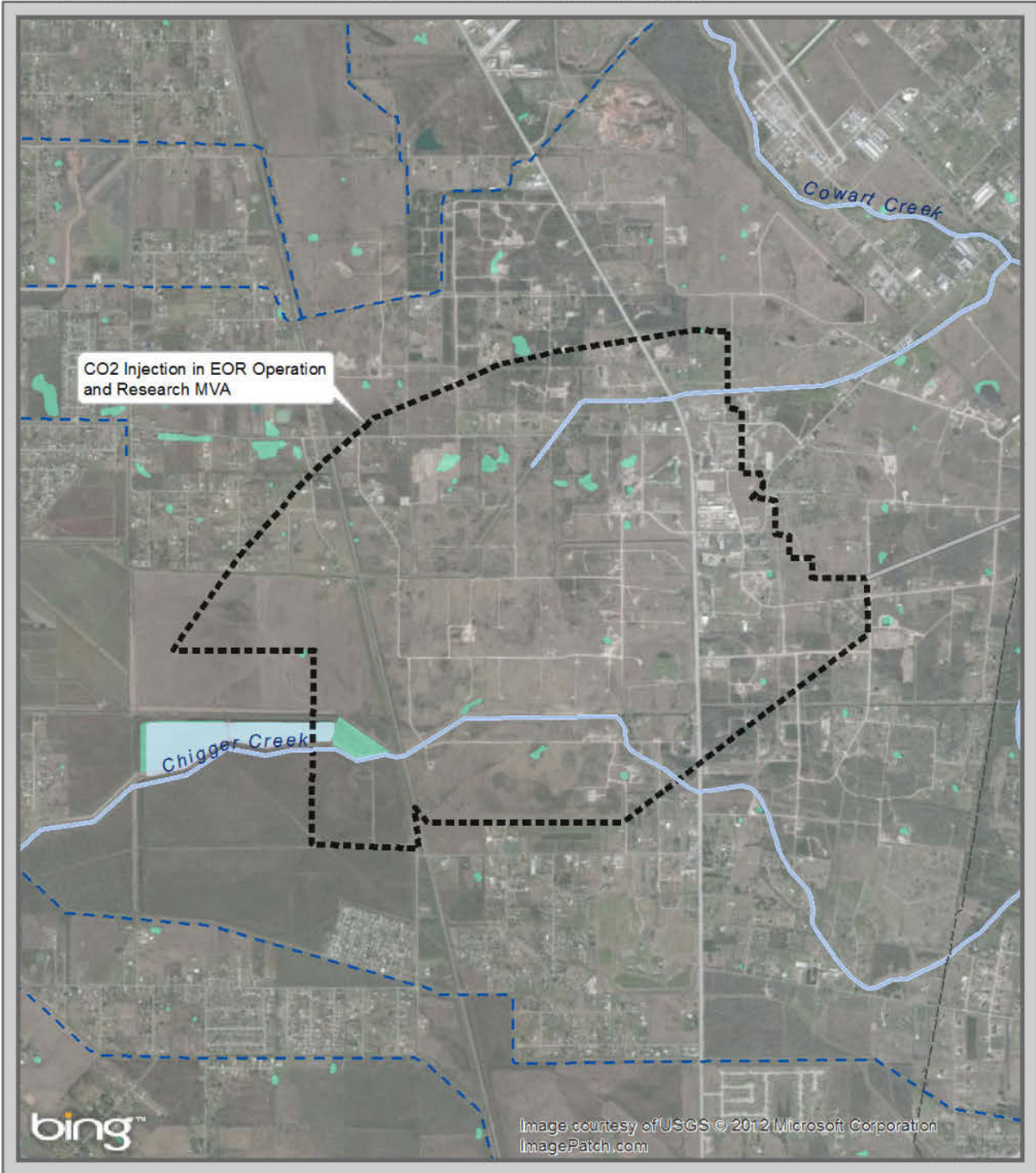

0 0.125 0.25 0.5
Miles







-  Canal/Ditch
-  Stream/River
-  NWI Wetland
-  Existing EOR Operations
-  Existing Green Pipeline
-  CO2 Injection in EOR Operation and Research MVA

Figure 3.4-3
FEMA Floodplains within Vicinity of
CO₂ Injection and Research MVA
Brazoria County, Texas

This page left blank intentionally.

including marine worms, blue crabs, bottom-dwelling fish and their habitat. Much of the contamination is due to historical releases from two refining facilities located along the bayou, which required cleanup and restoration (NOAA 2012b).

For waters primarily impacted by nonpoint sources, the LDEQ has developed the Nonpoint Source Pollution Management Plan. To address water quality concerns in this watershed, in 1999 the Calcasieu Parish Planning Division submitted a project to work with the City of Lake Charles and surrounding communities on nonpoint source problems associated with urban, home sewage, and hydro-modification. The EPA and NOAA also have the Coastal Nonpoint Pollution Control Program, which guides local watershed planning and management activities. The Coastal Management Division of the LDNR works in partnership with the LDEQ's Nonpoint Source Program to implement these management measures. Based on USGS stream flow data, the annual mean flow in the Sabine River is 2,060 cfs. Flow in the Calcasieu River ranges from 500 to 800 cfs above the project site to approximately 1,600 cfs below the project site (USGS 2011). However, water would be supplied to the LCCE Gasification plant and Lake Charles CCS CO₂ Capture and Compression facilities from the Toledo Bend Reservoir, an impounded segment of the Sabine River, through the existing SRA intake structure on the Sabine River Diversion Canal. The city of Sulphur would provide water for dust control during construction and for potable use during construction and operation of the LCCE Gasification plant. Sulphur's water supply system produces between 3 and 7 million gallons per day (City of Sulphur 2012).

Houston River Watershed

In the area of the CO₂ pipeline, the West Fork Calcasieu River and the Houston River are considered dystrophic (LDEQ 2000), indicating they are unable to support the dissolved oxygen (DO) standard set forth by the EPA and the LDEQ. The West Fork Calcasieu River and Houston River have been classified as dystrophic waters in Chapter 11 of the Louisiana Water Quality Regulations, with seasonal dissolved oxygen criteria of 5 mg/L in winter and 3 mg/L in summer. This designation was based upon a use attainability analysis that was approved by the EPA in 1986 and promulgated through the state.

The watershed area of the Houston River is sparsely populated, and land use is dominated by forestlands, agriculture, rangeland, wetlands, and five sewage treatment facilities. In 2001 the Houston River, Sub-segment 030806, was part of the 1999 ambient sampling monitoring program and was listed in the 2000 305(b) report because it was found to be "not supporting" its designated use of fish and wildlife propagation; it was "fully supporting" all other uses. The Houston River was subsequently scheduled for TMDL development with other listed waters in the Calcasieu River Basin. The suspected causes of impairment were organic enrichment/low DO, pH, salinity/TDS/chlorides, and sulfates. The suspected sources were natural sources, hydro-modification, and agriculture (LDEQ 2001).

Bayou d'Inde is on the 303(d) list for low DO and is the only Calcasieu River basin segment that does not meet its designated uses. Impairment of Bayou d'Inde results from industrial point sources, collection system failure, inflow and infiltration from urban runoff and storm sewers, land disposal, septic tanks, and contaminated sediments resuspension (LDEQ 2011). The bayou is listed as impaired due to elevated levels of mercury, copper, hexachlorobenzene, hexachlorobutadiene, and polychlorinated biphenyls (PCBs) in fish tissue, priority organic compounds, and tetrachloroethane (EPA 2011).

The Remedial Investigation Report by EPA and LDNR identified Bayou d'Inde as one of five Areas of Concern identified in the Calcasieu Estuary study area (Bayou d'Inde Group 2009). Major industrial development along this bayou began in 1920s (Bayou d'Inde Group 2009), eventually resulting in the need for corrective action and remediation of the bayou and adjacent marshes, including those within the proposed CO₂ pipeline route. The bayou and adjacent marshes contain hazardous substances, including PAHs, metals, PCBs, dioxins/furans, and other hazardous compounds released from facilities located along its shores, including from past spills and unpermitted discharges (Bayou d'Inde Group 2009). The LDEQ and the Bayou d'Inde Group (consisting of several of the facility operators) are working to further characterize Bayou d'Inde and its adjacent marshes and to determine what remedial actions should be implemented to address potential risks to human health and the environment. Based on wildlife toxicology studies conducted by the USGS Midwest Environmental Sciences Center along Bayou d'Inde, trace element and PAH concentrations were similar at upstream and downstream locations and at the reference area (Bayou d'Inde Group 2009).

Hastings Oil Field, Texas

Chigger Creek, which is recognized as Sub-segment 1101B by the TCEQ, is listed as an unclassified waterbody from its headwaters near CR 143, in Brazoria County at the Brazos River Authority Canal, to FM 528 and its confluence with Clear Creek Tidal. This creek is 12 miles in length and has a watershed area of approximately 45 square miles (TCEQ 2011a). TCEQ designated Chigger Creek for Contact Recreation and High Aquatic Life. Cowart Creek, recognized as Sub-Segment 1102A by the TCEQ, is an unclassified waterbody, or intermittent stream with perennial pools, from the confluence with Clear Creek in Galveston County to west of State Highway 35 in Brazoria County (TCEQ 2011a).

The TCEQ periodically monitors water quality in rivers and streams, including Cowart, Chigger, and Clear Creeks, and has detected impairments for bacteria concentrations in segments of Chigger Creek and Cowart Creek (TCEQ 2011b, 2011c). The bacterial impairments reported for segments of Chigger Creek and Cowart Creek in the West Hastings research MVA area primarily result from discharges of domestic wastewater and nonpoint-source runoff from agricultural areas (DOE 2011). The TCEQ plans to address these impairments through the TMDL process.

The public water supply in Brazoria County, Texas comes from groundwater (see Section 3.5).

3.4.3 Wetlands

Wetlands, which include swamps and marshes, are areas inundated or saturated by surface or groundwater at a frequency and duration sufficient to support, and that under normal circumstances do support, a prevalence of vegetation typically adapted for life in saturated soil conditions (USACE 1987). Wetlands exhibit the following three criteria: wetland hydrology, hydric soils, and support a predominance of hydrophytic vegetation (USACE 1987, 2007). Wetlands restore and maintain water quality by removing and retaining nutrients and pollutants contained in storm water runoff that would otherwise flow directly into the water column of a receiving open-water body. Wetlands provide habitat for a diversity of plants and animals, including fish, shellfish, waterfowl, shorebirds, wading birds, songbirds, and mammals. Wetlands provide flood control by retaining water that would otherwise flood nearby relatively higher areas, and depending upon their proximity to the coast, act as storm buffers by protecting surrounding inland areas on the Louisiana coastal plain from wave action.

LCCE Gasification Plant and Lake Charles CCS Project CO₂ Capture and Compression Facilities Site

As previously described, the Calcasieu Estuary includes many types of wetlands, such as semi-inundated marsh areas, open-water lakes, and bayous. Prior to site preparation, the LCCE Gasification plant site contained 26.2 acres cypress-tupelo and emergent freshwater marsh, along with 2,200 linear feet of riverine shoreline (URS 2010). A jurisdictional wetland determination was conducted by the USACE New Orleans District as part of a USACE permit approval for site development. Based on the wetland delineation and USACE jurisdictional determination, the Port of Lake Charles received a permit, issued on August 18, 2008, to construct a facility on the 70-acre LCCE Gasification plant site. The Port of Lake Charles addressed wetland impacts through off-site mitigation banking of 26.2 acres of the wetlands through an agreement with Stream Wetland Services, LLC. The construction parking area would occupy undeveloped land cleared of native vegetation and maintained by mowing. The area supports a grassy vegetative cover. The soil type mapped for this parcel is Mowata-Vidrine, a silt loam listed by the NRCS as a partially hydric soil. The area is flat with no open water features. The National Wetlands Inventory (NWI) map of this area shows no wetlands within this parcel.

The exact location of the equipment laydown and methanol and sulfuric acid storage area is uncertain; however, wetlands are present in the general vicinity of the LCCE Gasification plant site. If the site is located within an undeveloped location where the native forest is still intact, there is a high potential for wetlands to be present. Wetlands in the area include emergent marshes, bald cypress swamps, and mixed forested wetlands associated with the floodplains of Bayou D'Inde and the Calcasieu River.

The water supply pipeline route crosses Bayou d'Inde, an unnamed tributary of Bayou d'Inde, and Bayou Verdine (see Figure 3.4-2). The route crosses a broad, shallow forested depression, which is part of a tributary of Bayou D'Inde. The area contains both bald cypress swamp and emergent wetlands. The route also crosses the channel of Bayou D'Inde itself, as well as adjacent wetlands and open-water areas. On the north bank of Bayou D'Inde is a large shallow area of open water surrounded by emergent and scrub-shrub wetlands almost 1,000 feet in width. The south bank has an additional 250 feet of shallow depressional areas, with emergent wetlands and forested wetlands extending from the bank. The pipeline route also crosses an approximately 750-foot-wide riparian buffer of undeveloped forested wetland habitat associated with Bayou Verdine.

Along the hydrogen pipeline route, nearby surface waters include Bayou d'Inde, unnamed tributaries of Bayou d'Inde, the Houston River, and their associated wetlands (see Figure 3.4-2). A segment of the pipeline route crosses a freshwater canal and then traverses approximately 750 feet of undeveloped forest land. The forest appears to be a mixed pine/hardwood community that could support wetlands. Another segment of the route crosses Little Bayou D'Inde within an existing electric transmission ROW, where emergent wetlands may be present.

CO₂ Pipeline Route

Along the proposed CO₂ pipeline route, nearby surface waters include Bayou d'Inde, the Houston River and their associated wetlands, and the Sabine Diversion Canal (see Figure 3.4-2). Wetland data provided in this section was obtained from the Pre-Construction Notification (PCN) submitted to the USACE New Orleans District Regulatory Division in accordance with

General Condition 27 under Nationwide Permit (NWP) 12 - *Utility Line Activities*. A final determination of wetland impacts regarding the preferred route of the CO₂ pipeline is pending USACE evaluation; therefore, wetland impact acreages may change.

Denbury conducted field surveys to identify and delineate wetlands along the proposed CO₂ pipeline corridor beginning in April through September of 2011, in accordance with the 1987 USACE Wetlands Delineation Manual and the Regional Supplement to the USACE Wetland Delineation Manual: Atlantic and Gulf Coastal Plain Region. The USACE undertook a verification of the wetland delineation and determined wetland acreage within the proposed pipeline corridor. In addition, DOE reviewed background information, including soil survey maps, USGS topographic maps, and NWI maps to determine the potential locations of wetlands. Table 3.4-2 summarizes the wetlands within the preferred route of the proposed CO₂ pipeline. These quantities represent the wetlands delineated in the field by Denbury and the additional wetland areas identified by the USACE during their preliminary jurisdictional review of the project.

Table 3.4-2 Wetlands within the Proposed CO₂ Pipeline ROW

Wetland Type	Acreage
Emergent	8.23
Forested	10.34
Scrub-Shrub	0.45
Total wetlands	19.02

Source: Denbury 2013; USACE 2012

Hastings Oil Field, Texas

Several small, scattered wetlands occur in the area of the Hastings oil field according to the USFWS NWI (USFWS 2011) (see Figure 3.4-3). USFWS classifies these wetlands as palustrine emergent marsh, palustrine scrub-shrub, and forested/shrub wetlands (see Figure 3.4-3). Unlike river (riverine) or coastal flooding (estuarine) type wetlands, the hydrology of palustrine wetlands is sustained directly by precipitation. Palustrine wetlands may be permanently inundated or seasonally and temporarily wet, depending upon precipitation.

None of the proposed West Hastings research MVA program activities would occur within areas classified as wetlands by the NWI, since the proposed West Hastings research MVA program activities would be restricted to existing roads, work areas, and well sites.

3.4.4 Floodplains

Executive Order 11988, *Flood Plain Management*, requires that development in floodplains be avoided if practicable. A floodplain is any land area susceptible to inundation by floodwaters from any source. A 100-year flood is a flood having a 1% chance of being equaled or exceeded in magnitude in any given year. The 100-year floodplain is the area adjoining a river, stream, or watercourse covered by water in the event of a 100-year flood. Floods can be caused at any time by a variety of weather events, such as heavy thunderstorms, which can cause flashfloods (NCDC 2011).

These floodplains are mapped by the Federal Emergency Management Agency (FEMA) for insurance rate purposes and emergency response planning. These floodplains are assigned zone designations. Zone A indicates an area with a 1% annual chance of flooding and a 26% chance

of flooding over the life of a 30-year mortgage, and because detailed analyses are not performed for such area, no depths or base flood elevations are shown within these zones. Zone AE indicates the base floodplain where base flood elevations are provided. AE Zones are now used on new format Flood Insurance Rate Maps. Zone AO indicates river and stream flood hazard areas with a 1% or greater chance of shallow flooding each year, usually in the form of sheet flow, with an average depth ranging from 1 to 3 feet. These areas have a 26% chance of flooding over the life of a 30-year mortgage. Average flood depths derived from detailed analyses are shown within these zones. Floodplain encroachment is any man-made obstruction or filling in of the floodplain that displaces the natural passage of floodwaters.

Calcasieu Parish, Louisiana

Figure 3.4-2 shows the LCCE Gasification plant and the Lake Charles CCS project CO₂ Capture and Compression facilities site and related project components relative to the FEMA Flood Insurance Rate Map (effective June 1, 1983) and Rita Recovery Map (panel numbers LA-KK19 and LA-KK20). The Advisory Base Flood Elevation (ABFE) for the site was 10 feet above mean sea level (MSL). The natural topographic elevations ranged from 2 feet to 11 feet MSL. The LCCE Gasification plant and Lake Charles CCS CO₂ Capture and Compression facilities site would be filled to an elevation that is above the ABFE (Levingston Engineers, Inc. 2011).

The proposed CO₂ pipeline route is located in proximity to the floodplains of Bayou d'Inde, the Houston River, and the Calcasieu River, and much of the proposed CO₂ pipeline route is located within 100-year floodplains of the Calcasieu River and its tributaries (see Figure 3.4-2). Therefore, the proposed CO₂ pipeline route would experience flooding conditions similar to those of the LCCE Gasification plant and Lake Charles CCS CO₂ Capture and Compression facilities site.

Hastings Oil Field, Texas

FEMA conducted a floodplain survey in the vicinity of the Hastings oil field and developed Flood Insurance Rate Maps (FEMA 2010) for the area. Areas identified as Special Flood Hazard Areas inundated by 100-year floods (Zones A, AE, and AO) occur within short distances of Chigger Creek and Cowart Creek (see Figure 3.4-3). The southern approximately one-third of the project area, including the two potential well locations, are located within the 100-year floodplain of Chigger Creek.

3.5 Groundwater

3.5.1 Regional Setting

Groundwater in Calcasieu Parish, Louisiana is contained in a shallow, unconfined aquifer and the deeper, confined Chicot aquifer. Groundwater in the shallow aquifer is unconfined and occurs as shallow as 1 to 3 feet below ground surface (bgs) (Lovelace and Johnson 1996). Recharge to this shallow aquifer is from infiltration of surface waters from precipitation, marshes, river bed discharges, and impoundment leakage. Groundwater flow, fluctuation, and quality are generally influenced by surface water quantity and quality as it intercepts the shallow groundwater (Lovelace and Johnson 1996). The shallow water-bearing zones of the 10-, 20-, and 36-foot sands encountered above the Chicot aquifer are no longer considered potential sources of water supply, either potable or non-potable. According to the Louisiana Department of Transportation and Development, water wells in these shallow sands are not used or planned to be used, as drinking water sources. The USGS confirms that the shallow sands in this area (i.e., such as the upper sands, the most shallow water-bearing units) are not currently being

utilized, and are not planned to be utilized (USGS2011a). Drinking water sources in Calcasieu Parish are from groundwater wells that range in depth from 205 feet to 850 feet bgs (USGS 2011a, 2011b).

The Chicot aquifer is the primary source of groundwater for public supply, irrigation, and industrial use in the area. The potable groundwater is obtained from the “200-”, “500-”, and “700-foot” sands of this aquifer. The 500-foot sand (the Bentley Formation) is the most prolific water-producing sand of the Chicot aquifer and serves as the principal source of freshwater for industries and agriculture throughout most of Calcasieu Parish. The 700-foot sand (the Williana Formation) supplies drinking water to the City of Lake Charles, as well as some farms and industrial plants in southern and central Calcasieu Parish.

Natural groundwater flow within the sands of the Chicot aquifer is to the south, toward the Gulf of Mexico. However, substantial pumping of groundwater from these sands over the last several decades has significantly altered the local flow direction, forming cones of depression within the Lake Charles Industrial Area and eliciting concern about saltwater intrusion (Zack 1971).

The Evangeline aquifer generally exhibits total dissolved solids concentrations in excess of 10,000 mg/L, thus making it unsuitable for human consumption (Whitfield 1975).

CO₂ Pipeline Route

Groundwater in the area of the proposed CO₂ pipeline is the same as described above.

Hastings Oil Field, Texas

Brazoria County, Texas, groundwater resources in the Texas Gulf Coast are contained in the Gulf Coast aquifer system, which forms a wide belt along the Gulf of Mexico from Florida to Mexico. In Texas, this aquifer provides water to all or parts of 54 counties, including Brazoria County. Regionally, the Gulf Coast aquifer system is comprised of the following four generally recognized water-producing formations, from youngest to oldest:

- The Chicot-Evangeline aquifer, the uppermost groundwater-bearing component;
- The Burkeville confining system;
- The Jasper aquifer; and
- The Catahoula Formation, which contains groundwater in relatively restricted sand layers near an outcrop area northwest of the West Hastings oil field area.

The Gulf Coast aquifer is recharged primarily by precipitation. Streams and irrigation canals provide additional local sources of recharge (TWDB 2002). Reported recharge rates for the Gulf Coast aquifer range from approximately 0.0004 to 2 inches per year, depending on precipitation amounts, vegetation and land use, irrigation, and soil type (Scanlon et al. 2002).

3.5.2 Groundwater Quality and Use

Calcasieu Parish, Louisiana

The Chicot aquifer system is the principal source of drinking water in southwestern Louisiana and for Calcasieu Parish, Louisiana. Although the majority of the population obtains drinking water from public supply wells pumping from the "500-foot" sand, about 26,000 people in the parish obtain drinking water from private domestic wells (USCB 1993). About 3,200 private domestic wells in Calcasieu Parish are screened in the Chicot aquifer system and currently registered as operable (USGS 2011b). Of these wells, about 1,800 are screened in the 200-foot sand at depths between approximately 100 and 300 feet. Another 80 wells are screened in the shallow sand at depths between 16 and 145 feet. Many unregistered wells also may exist.

Approximately 70% of the 800 million gallons per day (MGD) withdrawn from the Chicot aquifer in southwest Louisiana is used for rice irrigation and aquaculture (Southern Regional Water Program 2011). Approximately 110 MGD were pumped from the Chicot aquifer system for all uses in Calcasieu Parish in 1995 (TPWD 2011). Pumping of groundwater from the Chicot aquifer is causing saltwater intrusion into groundwater (USGS 1989; Zack 1971).

Brazoria County, Texas

In Brazoria County, Texas, the Evangeline and the Chicot aquifers are the only hydrologic units bearing fresh (less than 1,000 mg/l dissolved solids) or slightly saline water (1,000-3,000 mg/l dissolved solids) (Sandeen and Wesselman 1973). The chemical quality of the water in these aquifers varies with location. Factors causing this variance include interconnection of the aquifers and the presence of salt domes in or near the aquifers (Verbeek et al. 1979).

The Evangeline aquifer, which contains freshwater to depths of more than 1,800 feet below sea level, has as much as 415 feet of sand containing freshwater. The shallower Chicot aquifer is divided into a lower unit and an upper unit. In the northern part of Brazoria County, the lower unit has 100 to 290 feet of sand containing freshwater. The upper unit has less than 100 feet of sand containing freshwater at most locations and less than 50 feet in much of the county. The Chicot is the only source of fresh groundwater in the southern parts of the county. The groundwater wells constructed in Brazoria County typically have total depths ranging from approximately 60 feet to 1,400 feet. The quality of groundwater from these wells is generally good, with total dissolved solids ranging from approximately 480 to 950 mg/L.

According to the Texas Water Development Board (TWDB), a total of 65 wells are located within 2 miles of the site including: public, industrial, irrigation, domestic, plugged or destroyed, dewatering, commercial, and unused (TWDB 2011). Most of these wells are for public use and are located in Brazoria County; four of the wells are located in Galveston County. All of these groundwater wells are completed into the Chicot aquifer at depths ranging from approximately 20 to 800 feet (TWDB 2011).

The Brazoria County Groundwater Conservation District (BCGCD) was created by Texas statute to maintain and protect the groundwater resources of Brazoria County (BCGCD 2008). The BCGCD proactively addresses groundwater issues by working with groundwater users to manage and plan for groundwater use. Municipal and irrigation uses in Texas from the Gulf Coast aquifer account for 90% of the total ground water pumped from the aquifer (Baker, 1979). Over 1.1 million acre-feet of groundwater are annually pumped from this aquifer in Texas.

Figure 3.5-1 identifies 34 operational, demand, and emergency-use wells located within 2 miles of the West Hastings research MVA site. These wells belong to 28 public water systems. All of these groundwater wells are completed into the Chicot aquifer at depths ranging from 100 to 674 feet (average 409 feet, median 375 feet).

3.6 Biology

3.6.1 Vegetation

Calcasieu Parish, Louisiana

The proposed LCCE Gasification plant and Lake Charles CCS CO₂ Capture and Compression facilities are located within the Gulf Coastal Plain physiographic province of southwestern Louisiana (Daigle et al. 2006). The major vegetation communities of this province include coastal dunes and marshes, coastal prairie and grasslands, pine flatwoods and savannas, and mixed upland and wetland bottomland hardwood forests (USGS 2011). These major vegetation communities transition with distance from the Gulf Coast, elevation changes inland, and proximity to river and stream systems. Since the site is located inland from the Gulf, it is within the ecosystem identified by the U.S. Fish and Wildlife Service (USFWS) as the Lower Mississippi River Ecosystem and by Louisiana Department of Fish and Wildlife (LDWF) as the Gulf Coast Prairies and Marshes Ecoregion. Based on information from the National Wetlands Research Center (NWRC) Louisiana Land Use and Land Cover (LULC) dataset, there were gradations of habitat: upland forest and grassland, forested riparian, bottomland swamp, and freshwater emergent marsh.

This ecosystem and ecoregion provide the primary wintering habitat for mid-continent waterfowl populations, breeding and migration habitat for migratory songbirds returning from Central and South America (they are within a major flyway for migratory birds), and habitat for numerous resident wildlife species described in Section 3.6.2 below.

Prior to development, the project site was occupied by upland mixed hardwood-pine forest on the higher elevations, with 26.2 acres of bottomland cypress-tupelo swamp and freshwater emergent marsh in the lower elevations on the central and eastern portions of the property (URS 2008). The upland forest was evenly distributed in a variety of ecological settings in Louisiana at the higher elevations, on mid and lower slopes, and at the heads of drainages along small, intermittent streams such as on the project site prior to development. Generally, acidic sandy loams, silt loams, and silty clays supported this plant community, with hydrology ranging from mesic-wet to dry-mesic. Loblolly pine (*Pinus taeda*) generally comprised 20% or more of the overstory, with various associated hardwood species consisting of oak (*Quercus* sp.), elm (*Ulmus* sp.), and hickory (*Carya* sp.). Depending upon the amount of sunlight, undergrowth would be substantial, ranging from woody shrubs to numerous herbaceous groundcover species. Historically, mixed hardwood-loblolly pine forest is estimated to have occupied 500,000 to 1,000,000 acres in Louisiana, with the same amount thought to remain today, primarily north and northeast of Calcasieu Parish (LDNR 2011). However, the older, more natural examples of this habitat are threatened by conversion to pine plantations, agriculture, or other land uses.

Within 5 miles of the site, a mix of wetland and upland habitats extends along the upper reach of the Calcasieu River, intermixed with developed residential and industrial areas. This area is dominated by urban vegetation, marsh, mixed wetland, upland pine forest, upland mixed forest,

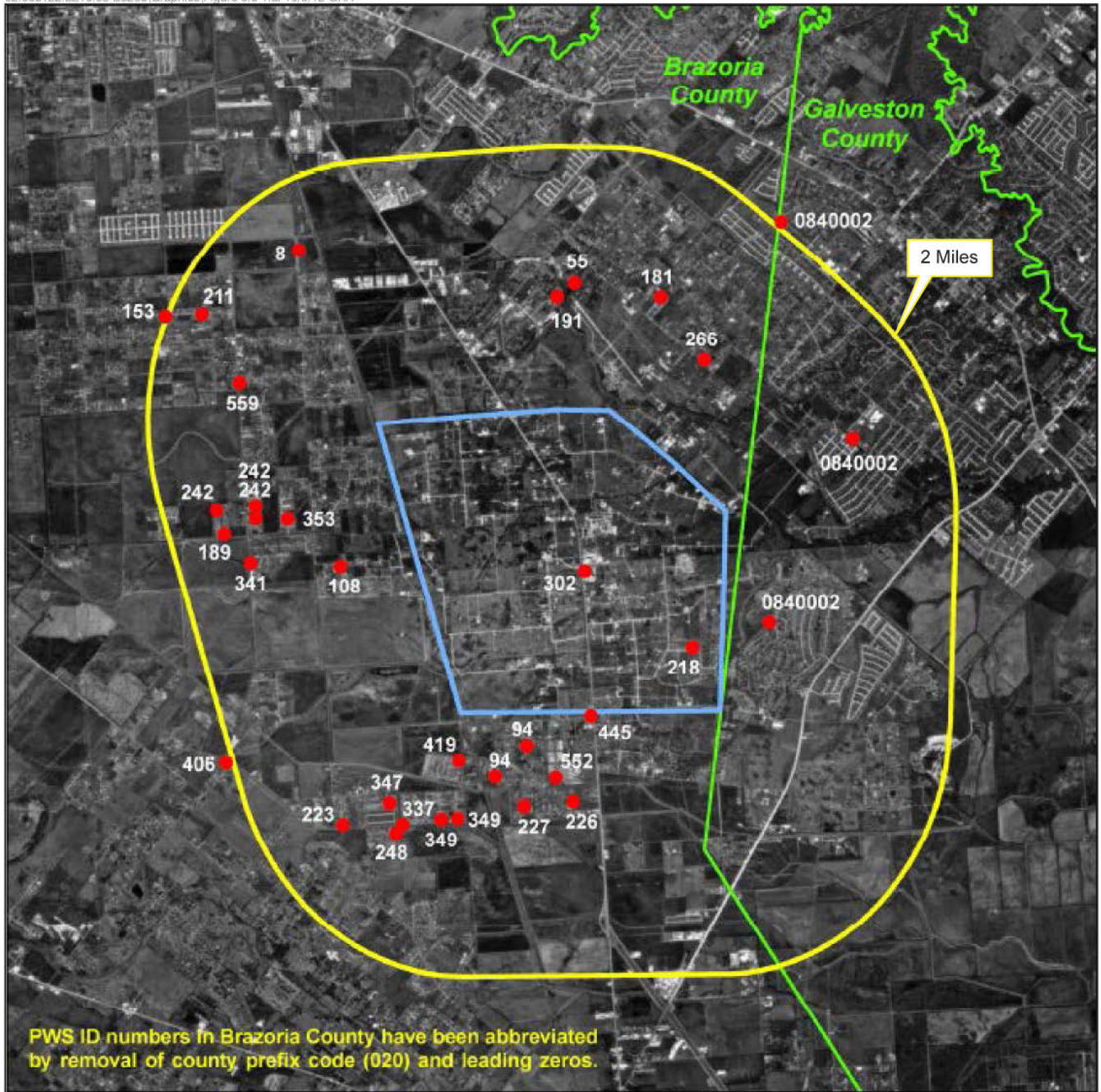

SOURCE: EIV Hastings Field

Figure 3.5-1
Operational, Demand, and Emergency Wells in the Chicot Aquifer Within 2 Miles of the CO₂ Injection and Research MVA Site

and forested wetland. Forested wetlands are divided into two types: bottomland hardwood forests and bald cypress/tupelo swamps (USFWS 2011a).

The bottomland hardwood forests occupy the broad floodplain areas that flank portions of the Calcasieu river system (USACE 1998). The bottomland hardwood forests are maintained by a natural hydrologic regime of alternating wet and dry periods generally following seasonal flooding events, which supports distinct assemblages of plants and animals associated with the particular landforms, hydric soils, and hydrologic regimes. These forest habitats are mixes of broadleaf deciduous, needle leaf deciduous, and evergreen trees and shrubs, and occupy approximately 275 acres adjacent to the 70-acre LCCE Gasification plant site. Within about a 2-mile radius, in an area south of Interstate 10, east of SH 108 (Cities Service Highway), and west of the Calcasieu River, forested habitat occupies approximately 530 acres. Forested habitats farther north and west of this site are restricted by local area development and agricultural land use to relatively narrow corridors along Bayou d'Inde and comprise approximately 2,000 acres. The larger unfragmented forested habitats are located to the north, along the Houston River.

Cypress/tupelo swamps are forested, alluvial habitats on intermittently exposed soils and are most commonly found along rivers and streams but also occur in back swamp depressions and swales. The soils are typically inundated or saturated by surface water or groundwater on a nearly permanent basis throughout the growing season, except during periods of extreme drought. Cypress/tupelo swamps have relatively low plant diversity. Bald cypress (*Taxodium distichum*) and water tupelo (*Nyssa aquatica*) are co-dominants. Common associates are swamp tupelo (*Nyssa biflora*), Drummond's red swamp maple (*Acer rubrum* var. *drummondii*), black willow (*Salix nigra*), pumpkin ash (*Fraxinus profunda*), green ash (*Fraxinus pennsylvanica*), planertree (*Planera aquatica*), water locust (*Gleditsia aquatica*), sweetspire (*Itea virginica*), and common buttonbush (*Cephalanthus occidentalis*). Undergrowth is often sparse because of low light intensity and extended wet periods. Cypress/tupelo swamps are found north of Calcasieu Lake and are often transitional between bottomland hardwood forest and riverine or freshwater marsh habitats. Approximately 388 acres of bottomland forest habitat and open marsh occur along the Calcasieu River floodplain about 2 miles to the southeast. Further south of the urban and agricultural developments associated with the towns of Carlyss and Prien, broad expanses of floodplain forested habitat extend along both sides of the Calcasieu River.

Freshwater marsh was observed on the site during wetland delineations performed in 2007. Freshwater marshes are found adjacent to forested wetlands along Bayou d'Inde, the Houston River, and other tributaries in the Calcasieu River basin above the tidal influence zone. Characteristic freshwater marsh plant species in this area are maidencane (*Panicum hemitomon*), spike sedge (*Eleocharis* spp.), alligatorweed (*Alternanthera philoxeroides*), saltmeadow cordgrass (*Spartina patens*), roseau cane (*Phragmites australis*), coon's tail (*Ceratophyllum demersum*), water hyacinth (*Eichhornia crassipes*), pickerelweed (*Pontederia cordata*), pennyworts (*Hydrocotyle* spp.), common duckweed (*Lemna minor*), and cattails (*Typha* spp.). Approximately 50 acres of freshwater marsh exist west and north of the site.

The construction parking area is an open mowed field supporting a grass cover. The exact location of the equipment laydown area and methanol/sulfuric acid storage area is uncertain; however descriptions of vegetation above are representative of the areas within 1 mile of the proposed project. The short linears for the utilities required for the proposed project would be located within existing utility ROWs, previously cleared of native forested vegetation.

The water supply and hydrogen pipeline routes support native upland and wetland forest, marsh, and urban areas with a mix of non-native and ornamental vegetation, as described above. The primary vegetation/habitat types crossed by the pipeline routes are developed/open space, woody wetlands, and shrub/scrub, summarized in Table 3.6-1.

Table 3.6-1 Vegetation and Land Cover Along the Water Supply and Hydrogen Pipelines¹

Land Cover Type	Water Supply Pipeline (acres)	Hydrogen Pipeline (acres)
Open Water	786.01	618.84
Developed, Open Space	573.93	1,321.07
Evergreen Forest	458.02	605.83
Mixed Forest	12.87	53.70
Shrub/Scrub	0	226.94
Grassland/Herbaceous	15.26	57.91
Pasture/Hay	17.38	841.67
Forested Wetlands	3,319.28	3,305.25
Emergent Herbaceous Wetlands	1,059.99	697.81
Total	6,242.74	7,729.02

¹ Acreage totals are based on the assumption of a 95-foot-wide ROW and land cover values from USGS 2006 NLCD (Fry et al. 2011).

CO₂ Pipeline Route

The routes proposed for the CO₂ pipeline supports upland and wetland forest, urban vegetation, and marsh similar to that described above. The primary vegetation/habitat types crossed by the connector pipeline route are forested wetlands, evergreen forest, and shrub/scrub, summarized in Table 3.6-2.

Table 3.6-2 Vegetation and Land Cover Crossed by the CO₂ Pipeline¹

Land Cover Type	Acres
Open Water	244.9
Developed, Open Space	444.6
Evergreen Forest	1,323.6
Mixed Forest	42.1
Shrub/Scrub	562
Grassland/Herbaceous	174.4
Pasture/Hay	217.6
Forested Wetlands	2,288
Emergent Herbaceous Wetlands	287.6
Total	5584.8

¹ Acreage totals are based on the assumption of a ½ mile buffer on either side of the pipeline centerline and land cover values from USGS 2006 NLCD (Fry et al. 2011).

Brazoria County, Texas

The proposed West Hastings research MVA program would be located in the Bluestem Grassland Vegetation Type of the Coastal Prairies of Oak-Prairie Wildlife District of the Gulf Coastal Plain province (TPWD 2011a). In pre-settlement times, this coastal tallgrass prairie covered approximately 9 million acres, of which 6.5 million were in Texas. This grassland was characterized by nearly 1,000 identified grass and forb plant species, including bushy bluestem (*Andropogon glomeratus*), slender bluestem (*Schizachyrium tenerum*), little bluestem, silver bluestem (*Bothriochloa saccharoides*), three-awn (*Aristida* spp.), buffalograss (*Bouteloua dactyloides*), bermudagrass (*Cynodon dactylon*), brownseed paspalum, single-spike paspalum (*Paspalum unispicatum*), smutgrass (*Sporobolus indicus*), sacahuista (*Nolina texana*), windmillgrass (*Chloris verticillata*), southern dewberry (*Rubus trivialis*), live oak (*Quercus virginiana*), mesquite (*Prosopis* spp.), huisache (*Acacia farnesiana*), baccharis (*Baccharis* spp.), and Macartney rose (*Rosa bracteata*) (USGS 2011; NPAT 2011). Today, less than 1% of the native prairie remains, with much of the remainder converted to improved pasture or rice, sugarcane, forage, and grain crops.

Historically, coastal prairie and grasslands terrestrial vegetation communities characterized the West Hastings research MVA area. However, since settlement and urbanization of the area, particularly with oil and gas production, the vegetation reflects a mix of remnant coastal prairie and grassland, urban vegetation, and scattered trees and shrubs.

3.6.2 Wildlife

Calcasieu River Watershed, Louisiana

The diverse habitats along the Calcasieu River and Bayou d'Inde support a wide variety of terrestrial wildlife. Table 3.6-3 lists common species in this ecoregion. Common mammals within the area include the Virginia opossum (*Didelphis virginiana*), nine-banded armadillo (*Dasypus novemcinctus*), coyote (*Canis latrans*), raccoon (*Procyon lotor*), white-tailed deer (*Odocoileus virginianus*), nutria (*Myocaster coypus*), muskrat (*Ondatra zibethicus*), and swamp rabbit (*Sylvilagus aquaticus*). Game species include squirrel, rabbit, and deer. Major furbearing species are raccoon, opossum, mink (*Neovison vison*), bobcat (*Lynx rufus*), and nutria. The harvesting of alligators (*Alligator mississippiensis*) and feral hogs (*Sus scrofa*) is also permitted. The wildlife that commonly occur in this region are capable of adapting to a variety of habitats.

More than half of the species of birds that occur in North America reside or spend a portion of their migration in Louisiana, given its location within one of the major bird migratory flyways (USFWS 2011b). At least 265 bird species have been recorded in the Cameron Prairie and Sabine National Wildlife Refuges (NWRs), which are located approximately 20 miles to the southeast and southwest of the project site, respectively. Of these 265 bird species, the most abundant include several species of ducks and geese, which spend the winter on area marshes and forested wetlands. In addition to migratory waterfowl, neotropical migratory birds use the area. Louisiana, located in the center of the migratory flyway, is used by birds crossing the Gulf of Mexico to and from the Yucatan peninsula during both the spring and fall migrations. Wintering ducks and geese arrive in November; Wilson's snipe (*Gallinago delicata*) and American woodcock (*Scolopax minor*) also arrive in the fall and spend the winter. The Cameron Prairie and Sabine NWRs provide nesting habitat for colonies of egrets, herons, cormorants (*Phalacrocorax* spp.), ibis, and anhingas (*Anhinga anhinga*). Roseate spoonbills (*Ajaia ajaja*) can be seen feeding from late summer to early winter. Among the more common water birds are

the laughing gull (*Larus atricilla*), royal tern (*Sterna maxima*), brown pelican (*Pelecanus occidentalis*), and black skimmer (*Rynchops niger*) (Ehrlich et al. 1988). Other birds commonly found in the marshes include the marsh wren (*Cistothorus palustris*), seaside sparrow (*Ammodramus maritimus*), red-winged blackbird (*Agelaius phoeniceus*), Wilson’s snipe, American woodcock, red-tailed hawk (*Buteo jamaicensis*), northern harriers (*Circus cyaneus*), and various species of sandpipers. Other migratory birds common to forested wetlands include Swainson’s warbler (*Limnothlypis swainsonii*), swallow-tailed kite (*Elanoides forficatus*), cerulean warbler (*Setophaga cerulean*), prothonotary warbler (*Protonotaria citrea*), Kentucky warbler (*Geothlypis formosa*), and yellow-billed cuckoo (*Coccyzus americanus*).

Off-site activities associated with the LCCE Gasification plant also reflect the diverse habitats along the Calcasieu River, Houston River, Bayou Verdine, and Bayou d’Inde. The terrestrial wildlife species that occur along the proposed pipeline routes and equipment laydown area are the same as described above. The proposed construction parking area would have limited wildlife species due to the routine mowing of this site. Resident birds, common insects, and soil fauna that can withstand the routine mowing would occasionally use the site.

Table 3.6-3 Common Fauna in the Northern Humid Gulf Coastal Prairies Ecoregion

Common Name	Scientific Name	Group
White-tailed deer	<i>Odocoileus virginianus</i>	Mammal
Beaver	<i>Castor Canadensis</i>	Mammal
Gray squirrel	<i>Sciurus carolinensis</i>	Mammal
Raccoon	<i>Procyon lotor</i>	Mammal
Bobcat	<i>Lynx rufus</i>	Mammal
Skunk	<i>Spilogale</i> sp. and <i>Mephitis</i> sp.	Mammal
Armadillo	<i>Dasyus novemcinctus</i>	Mammal
Mourning dove	<i>Zenaida macroura</i>	Avian
Wild turkey	<i>Meleagris gallopavo</i>	Avian
Bobwhite quail	<i>Colinus virginianus</i>	Avian
Red-tailed hawk	<i>Buteo jamaicensis</i>	Avian
Eastern bluebird	<i>Sialia sialis</i>	Avian
Green heron	<i>Butorides virescens</i>	Avian
American white pelican	<i>Pelecanus erythrorhynchos</i>	Avian
Great blue heron	<i>Ardea herodias</i>	Avian
Snowy egret	<i>Egretta thula</i>	Avian
Wood duck	<i>Aix sponsa</i>	Avian
Barred owl	<i>Strix varia</i>	Avian
Red-headed woodpecker	<i>Melanerpes erythrocephalus</i>	Avian
Copperhead snake	<i>Agkistrodon contortrix</i>	Reptile
Diamondback rattlesnake	<i>Crotalus</i> sp.	Reptile
Box turtle	<i>Terrapene</i> sp.	Reptile
Texas salamander	<i>Eurycea neotenes</i>	Amphibian
Great plains narrow-mouthed toad	<i>Gastrophryne olivacea</i>	Amphibian
Bullfrog	<i>Rana catesbeiana</i>	Amphibian

Source: TPWD 2011a, 2011c.

Hastings Oil Field, Texas

The vegetative communities of the West Hastings research MVA area favor the presence of terrestrial wildlife that is tolerant of human disturbance and species that are more generalists in

terms of habitat requirements. Common mammals likely to occur include Virginia opossum, nine-banded armadillo, Eastern cottontail (*Sylvilagus floridanus*), coyote, common raccoon, striped skunk (*Mephitis mephitis*), white-tailed deer, hispid cotton rat (*Sigmodon hispidus*), skinks (*Plestiodon* spp.), and several species of snake.

Common bird species likely to occur within the West Hastings oil field research MVA site include red-tailed hawk, killdeer (*charadrius vociferus*), mourning dove (*Zenaida macroura*), great horned owl (*Bubo virginianus*), red-bellied woodpecker (*Melanerpes carolinus*), northern flicker (*Colaptes auratus*), scissor-tailed flycatcher (*Tryannus forficatus*), blue jay (*Cyanocitta cristata*), American crow (*Corvus brachyrhynchos*), northern mockingbird (*Mimus polyglottos*), northern cardinal (*Cardinalis cardinalis*), eastern meadowlark (*Sternella magna*), grackles (*Quiscalus* spp.), and red-winged blackbird.

3.6.3 Aquatic Ecology

Calcasieu Estuary, Louisiana

The aquatic ecology of the region encompasses the interconnection between the Gulf of Mexico, the Calcasieu Estuary system, and adjacent marshes and forested wetlands (Pritchard 1967; LDWF 2011). The aquatic organisms in the region reflect this rich diversity of habitats and include fish, reptiles, and invertebrates. Many of the open-water species (finfish and shellfish) of the Gulf of Mexico depend on estuaries for portions of their life cycle (e.g., for reproduction, nursery areas, and food) and migrate from the Gulf into the open waters within the estuary such as the Calcasieu River and its tributaries (LA CWCS 2005). Common species include Gulf menhaden (*Brevoortia patronus*), killifish (*Fundulus* spp.), sheepshead minnow (*Cyprinodon variegatus*), mosquitofish (*Gambusia affinis*), silversides (*Menidia beryllina*), striped mullet (*Mugil cephalus*), Atlantic croaker (*Micropogonias undulatus*), spot (*Leiostomus xanthurus*), hardhead catfish (*Arius felis*), silver perch (*Bairdiella chrysura*), and hogchoker (*Trinectes maculatus*) (LDWF 2011).

Table 3.6-4 provides a list of the common finfish species that may occur in the immediate project area and likely to occur in Bayou d’Inde, the Houston River, the Calcasieu River, and the numerous unnamed tributary streams and open-water ponds within the Northern Humid Gulf Coastal Prairies ecoregion.

Table 3.6-4 Finfish Species Potentially Occurring in the Northern Humid Gulf Coastal Prairie Ecoregion

Common Name	Scientific Name
Largemouth bass	<i>Micropterus salmoides</i>
Black crappie	<i>Pomoxis nigromaculatus</i>
Bluegill	<i>Lepomis macrochirus</i>
Spotted sucker	<i>Minytrema melanops</i>
Red-eared sunfish	<i>Lepomis microlophus</i>
Channel catfish	<i>Ictalurus punctatus</i>
Black drum	<i>Pogonias cromis</i>
Alligator gar	<i>Atractosteus spatula</i>
White crappie	<i>Poxomis annularis</i>

Source LDWF 2011.

Essential Fish Habitat (EFH) includes “those waters and substrate necessary to fish for spawning, breeding, feeding, or growth to maturity” in the Magnuson-Stevens Fishery Conservation and Management Act, as amended, PL 104-208. This definition extends to habitat specific to an individual species or group of species, whichever is appropriate to a particular Fishery Management Plan. EFHs located within the immediate area are estuarine emergent wetlands, mud/sand/shell/rock substrates, and the estuarine water column. EFHs in the region include Bayou d’Inde, the Houston River and Calcasieu River, and their associated wetlands. Species managed under the EFH in the Gulf of Mexico include six shrimp species, red drum (*Sciaenops ocellatus*), 42 reef fish species, two stone crab species, two spiny lobster species, and seven coastal migratory pelagic species (NOAA 2011a, 2011b). With the exception of the red drum, none of these species occur within the project area’s water column. The red drum is known to have a winter range that extends into the Calcasieu River (NOAA 2011c).

Oyster resources are of particular economic and recreational importance in the Calcasieu Lake and estuary. LDWF designated Calcasieu Lake as a Public Oyster TONGING Area. The distribution of the eastern oyster (*Crassostrea virginica*) in Calcasieu Lake depends on several factors, including the suitability of the substrate and salinity. No oyster resources occur within the project area.

Offsite activities associated with the LCCE Gasification plant also reflect the Northern Humid Gulf Coastal Prairies ecoregion. The aquatic ecology and the open-water species found within Bayou Verdine, Bayou d’Inde, and the Houston River where the water supply and hydrogen pipelines would cross are the same as described above. The proposed site for the construction parking area has no open-water features.

CO₂ Pipeline Route

The terrestrial wildlife species that occur in the area of the LCCE Gasification site described above would also occur along the proposed CO₂ pipeline route. The aquatic ecology in the area of the LCCE Gasification site described above would also occur along the proposed CO₂ pipeline route.

Cowart and Chigger Creeks, Texas

The aquatic ecology of the West Hastings research MVA site includes the two nearby streams of Cowart Creek and Chigger Creek and scattered stock tanks, or man-made ponds. The two creeks flow eastward and are tributaries of Clear Creek. No unique aquatic habitats occur within or near the boundaries of the West Hastings research MVA site.

3.6.4 Threatened and Endangered Species

The ESA of 1973 provides a program for the conservation of threatened and endangered species and the habitats in which they are found. The ESA regulations prohibit the “take” (i.e., to harass, harm, pursue, hunt, shoot, wound, kill, trap, capture, or collect, or attempt to engage in any such conduct) of any listed species, as well as the destruction or modification of its “critical habitat” (i.e., habitat that is essential to the survival of the species). DOE sent coordination letters to the USFWS and LDWF on October 3, 2012 (Appendix C) regarding any records of occurrence or the potential for occurrence of ESA-protected species and their habitats. DOE also reviewed surveys and desktop studies performed on behalf of Leucadia and Denbury to characterize the presence and habitat of state and federally protected species.

Calcasieu Parish, Louisiana

A review of USFWS (2011c) and LDWF (2011) databases of threatened and endangered species for Calcasieu Parish identified the state- and/or federally listed species listed in Table 3.6-5 as occurring or believed to occur within the Parish.

Table 3.6-5 Federal and State Protected Species Potentially Occurring in the Area

Common Name	Scientific Name	Federal Status	State Status
Red-cockaded woodpecker	<i>Picoides borealis</i>	Endangered	Endangered
Louisiana black bear	<i>Ursus americanus luteolus</i>	Threatened	Threatened
Bald Eagle	<i>Haliaeetus leucocephalus</i>	Delisted	Threatened
Sprague's pipit	<i>Anthus spragueii</i>	Candidate	

Sources: USFWS 2011c; LDWF 2011.

The preferred habitat for the red-cockaded woodpecker is old-growth, fire-maintained pine woodlands with little to no mid-story vegetation. The preferred habitat for the Louisiana black bear is bottomland hardwood forests and large tracts of inaccessible forested areas (USFWS 1995). The Sprague's pipit occurs only in Louisiana during migration and winter; its preferred habitat is native upland prairie and coastal grasslands. Due to the lack of suitable habitat required by each of these species, there is a low likelihood that the red-cockaded woodpecker, Louisiana black bear, and Sprague's pipit occur at the project site.

The bald eagle is closely associated with large waterbodies and requires large trees for nesting and roosting. The undeveloped areas adjacent to and nearby the site support forested habitat, including forested wetlands that could potentially provide suitable nesting and foraging habitat for the bald eagle.

No designated critical habitats, state or federal parks, wildlife refuges, or wildlife management areas occur at or near the proposed project site (NBII 2011). No rare, threatened, or endangered species or critical habitats are known to exist at the project site or within 1 mile.

The state- and federally listed threatened and endangered species that could occur along the proposed water supply and hydrogen pipeline routes are the same as those described above for the area within 1 mile of the project site. The proposed construction parking area is routinely mowed and supports a grass cover. No habitat conditions are present to support the listed threatened and endangered species.

CO₂ Pipeline Route

The state- and federally listed threatened and endangered species that could occur in the area of the LCCE Gasification site described above could also occur along the proposed CO₂ pipeline route. In addition to the species identified in Table 3.6-5, consultations with the USFWS and LDWF identified additional biological resources along the CO₂ pipeline route: one state-imperiled species, the old prairie crawfish (*Fallicambarus macneesei*); and nesting colonies of colonial wading bird species, which are protected by the Migratory Bird Treatment Act (MBTA) and potentially occur in Calcasieu Parish (USFWS 2011c). The old prairie crawfish prefers wet meadow habitats, including ditches flooded by heavy rains, as well as sandy clay soils of roadside ditches (Hobbs and Robison 1989). While this habitat was identified as present along

the proposed CO₂ pipeline route during the field surveys conducted from mid-April through September 2011, no burrows were identified, nor was there any other indication that the old prairie crawfish was present along the route. In addition, this species may actually be extirpated from Calcasieu Parish (NatureServe 2011); therefore, it is unlikely that the old prairie crawfish occurs along the proposed CO₂ connector pipeline route.

Colonially nesting wading birds typically prefer a nesting habitat of snags and mature trees with large lateral limb structures near water, though some species prefer shrubby habitat (also near water). Suitable habitat is present along the proposed CO₂ pipeline route in the vicinity of Bayou d’Inde and the Houston River; therefore, colonial wading birds may occur. The Great blue heron (*Ardea herodias*), yellow-crowned night heron (*Nycticorax nycticorax*), snowy egret (*Egretta thula*), and white ibis (*Eudocimus albus*) were observed along the CO₂ pipeline route during the 2011 field surveys conducted from mid-April through September.

Brazoria County, Texas

A review of the USFWS list of threatened and endangered species known to occur or that could occur within Brazoria County (USFWS 2011d) identified five federally listed endangered species, three federally listed threatened species, and two delisted species, as summarized in Table 3.3-6. The West Indian manatee, the six listed turtle species, and the brown pelican are restricted to the Gulf and bay systems along the coastline of Brazoria County.

Table 3.6-6 Federal Protected Species Potentially Occurring in Brazoria County

Common Name	Scientific Name	Federal Status
Whooping crane	<i>Grus americana</i>	Endangered
West Indian manatee	<i>Trichechus manatus</i>	Endangered
Hawksbill sea turtle	<i>Eretmochelys imbricata</i>	Endangered
Leatherback sea turtle	<i>Dermochelys coriacea</i>	Endangered
Kemp’s ridley sea turtle	<i>Lepidochelys kempii</i>	Endangered
Piping plover	<i>Charadrius melodus</i>	Threatened
Green sea turtle	<i>Chelonia mydas</i>	Threatened
Loggerhead sea turtle	<i>Caretta caretta</i>	Threatened
Brown pelican	<i>Pelecanus occidentalis</i>	Delisted
Bald Eagle	<i>Haliaeetus leucocephalus</i>	Delisted

Source USFWS 2011d.

The whooping crane would occur only during its spring and fall migration between its wintering grounds at Aransas NWR in Aransas County, Texas, and its breeding grounds at Wood Buffalo National Park in Canada. The preferred stopover habitat for the whooping crane is large wetland complexes (>10 acres) that are adjacent to foraging areas such as croplands (Lewis 1995). Due to the lack of suitable stopover habitat, there is a low likelihood of the whooping crane occurring on the Hastings oil field.

The preferred wintering habitat of the piping plover is beaches and bayside mudflats or salt flats. These habitats are not present on the Hastings oil field.

The bald eagle is found year-round in Brazoria County. The West Hastings research MVA site lacks suitable habitat to support nesting or roosting individuals. The bald eagle could occur as a transient or during foraging, but this would likely be a rare occurrence.

A review of TPWD annotated county lists of rare species identified an additional 10 state-listed threatened or endangered species that occur or are believed to occur within Brazoria County (TPWD 2011b). The 10 species are the peregrine falcon (*Falco peregrinus*), reddish egret (*Egretta rufescens*), sooty tern (*Sterna fuscata*), white-faced ibis (*Plegadis chihi*), white-tailed hawk (*Buteo albicaudatus*), smooth pimpleback (*Quadrula houstonensis*), Texas fawnfoot (*Truncilla macrodon*), alligator snapping turtle (*Macrochelys temminckii*), Texas horned lizard (*Phrynosoma cornutum*), and timber/canebrake snake (*Crotalus horridus*).

The peregrine falcon occurs in Brazoria County both as a migrant across Brazoria county and as a winter resident along the coast. The preferred stopover and overwintering habitats for this species include wetlands, flooded fields, and coastlines because these habitats tend to support large populations of waterfowl or shorebirds which are their preferred prey. These habitats are not present on the West Hastings research MVA site.

The white-tailed hawk breeds in coastal grasslands and semi-arid brushland (Ehrlich et al. 1988), primarily south of Matagorda Bay, along the central and lower coasts of Texas (Lockwood and Freeman 2004). The West Hastings research MVA site is within the breeding range of the white-tailed hawk; however, the site does not contain suitable habitat to support nesting of the species. The white-tailed hawk could potentially occur as a transient individual, but this would likely be a rare event. The Texas horned lizard has a moderate likelihood of occurring in the sparsely vegetated open, arid, and semi-arid habitats on the site. The reddish egret, sooty tern, white-faced ibis, smooth pimpleback, Texas fawnfoot, alligator snapping turtle, and timber/canebrake snake would not occur within the site because the site does not support the required habitat and is outside these species' foraging range. The TPWD Wildlife Diversity Program provides data from the Texas Natural Diversity Database (TXNDD) on sensitive species or critical habitats. There are no known observations of federally or state-listed threatened, endangered, or rare species at or within 5 miles of the West Hastings research MVA site.

The small portions (less than 1%) of the site that are remnant prairie could provide habitat for a unique diversity of insects, including butterflies, dragonflies, and numerous kinds of bees, wasps, ants, grasshoppers, beetles, and praying mantis (NPAT 2011). The most conspicuous prairie insects are the butterflies and skippers, with more than 100 species found in the prairies of both Louisiana and Texas. The gulf fritillary (*Agraulis vanilla*), also known as the passionvine butterfly, is the most common butterfly species found in the Coastal Prairie. Monarchs (*Danaus plexippus*), whose larvae depend on the many milkweeds found in the Coastal Prairie, frequently visit the remnant prairies of both Texas and Louisiana. More than 100 different species of dragonfly that eat mosquitoes and other insects utilize the wet prairie remnants. More than a dozen plant species are listed as imperiled or critically imperiled in Texas, including the Texas windmill grass (*Chloris texensis*), coastal gay-feather (*Liatris bracteata*), and Correll's false dragon-head (*Physostegia correllii*). Cattle grazed the site for many years and the site was developed for oil production. It is therefore unlikely that these plant species are present, and the host of insect species would be present only transiently during butterfly migration.

3.6.5 Invasive Species

Southwest Louisiana

Invasive species are non-native species, either plants or animals, regulated as pests; injurious wildlife; and/or nonindigenous aquatic nuisance species known to cause environmental and economic damage (LDWF 2004). Invasive species of concern in Louisiana include the following: coyote, nutria, feral pigs, giant salvinia (*Salvinia molesta*), purple loosestrife (*Lythrum salicaria*), kudzu (*Pueraria montana* var. *lobata*), water hyacinth, cogon grass (*Imperata cylindrica*), Asian clam (*Corbicula fluminea*), zebra mussel (*Dreissena polymorpha*), Australian spotted jellyfish (*Phyllorhiza punctate*), rainbow smelt (*Osmerus mordax*), Rio Grande cichlid (*Cichlasoma cyanoguttatum*), boll weevil (*Anthonomus grandis*), Formosan termite (*Coptotermes formosanus*), Asian tiger mosquito (*Aedes albopictus*), and the *Aedes aegyti* mosquito (Tulane University 2011).

CO₂ Pipeline Route

The invasive species that could occur along the proposed CO₂ pipeline route are the same as described above.

Gulf Coast, Texas

The Texas Department of Agriculture publishes a list of invasive and noxious plant species in the Texas Administrative Code (4 TAC §19.300(a)). This list includes 26 plant species that are classified as noxious, including four that are also classified as invasive. In addition, the TPWD maintains a list of “harmful or potentially harmful fish, shellfish, and aquatic plants” under Title 31, Part 2, Chapter 57, Subchapter A, Rule §57.111. According to the Texas Invasive Plant and Pest Council, a partnership between several federal and Texas state agencies, the invasive plant species (regulated at the federal and/or state level) of most concern in the Gulf Coast Prairies and Marshes ecoregion include giant salvinia, Chinese tallow tree (*Triadica sebifera*), salt cedar (*Tamarix ramosissima*), deep-rooted sedge (*Cyperus enterianus*), Brazilian peppertree (*Schinus terebinthifolius*), common water hyacinth, and alligatorweed (Texas Invasive Plant and Pest Council 2011).

3.7 Cultural Resources

Section 106 of the National Historic Preservation Act (NHPA) and its implementing regulations at 36 CFR 800 (incorporating amendments effective August 5, 2004) “require federal agencies to take into account the effects of their undertakings on historic properties, and afford the Advisory Council on Historic Preservation a reasonable opportunity to comment on such undertakings.”

The National Historic Preservation Act of 1966 (16 USC 470), as amended, establishes a program for the preservation of historic properties throughout the nation.

For purposes of this EIS, cultural resources are:

- archaeological resources, including prehistoric and historic archaeological sites;
- architectural or built resources, including extant standing structures and cemeteries; or
- Native American resources, including Traditional Cultural Properties important to Native American tribes.

Historic properties are a subset of cultural resources and consist of “any prehistoric or historic district, site, building, structure, or object included in, or eligible for inclusion in, the National Register of Historic Places (NRHP) maintained by the Secretary of the Interior.” Historic properties can include “artifacts, records, and remains related to and located within such properties...[P]roperties of traditional religious and cultural importance to an Indian tribe or Native Hawaiian organization that meet National Register criteria” (36 CFR 800.16[1][1]) are also historic properties.

The criteria for determining whether a cultural resource is an historic property can be found in 36 CFR Part 80 and in Chapter II, “The National Register Criteria for Evaluation,” of National Register Bulletin 15, *How to Apply the National Register Criteria for Evaluation* (NPS 1990). A cultural resource is considered a historic property when:

“The quality of significance in American history, architecture, archeology, engineering, and culture is present in districts, sites, buildings, structures, and objects that possess integrity of location, design, setting, materials, workmanship, feeling, and association and:

- A. That are associated with events that have made a significant contribution to the broad patterns of our history; or
- B. That are associated with the lives of significant persons in our past; or
- C. That embody the distinctive characteristics of a type, period, or method of construction, or that represent the work of a master, or that possess high artistic values, or that represent a significant and distinguishable entity whose components may lack individual distinction; or
- D. That have yielded, or may be likely to yield, information important in history or prehistory.

The geographical area for evaluating the impacts and effects on cultural resources and historic properties, respectively, is referred to as the area of potential effects (APE). For archaeological resources, the APE is defined as all areas where ground would potentially be disturbed from new construction associated with the proposed project. For architectural resources, the APE is defined as a distance of 500 feet from the project components. For any new permanent aboveground project-related structures or facilities built for the project, the APE includes the footprint of these proposed facilities, as well as those areas within 500 feet of the proposed facility. The viewshed of any proposed new permanent aboveground project-related structures or facilities was not used to define the architectural APE, as the presence of existing industrial facilities adjacent to the project site generates a greater visual impact than the proposed new aboveground facilities, which would be considerably smaller than surrounding structures. DOE determined that the area of potential effects (APE) for the proposed project and connected action consist of the new project-related facilities associated with the Lake Charles CCS project and LCCE Gasification, which are located in Calcasieu Parish, Louisiana and in Brazoria County, Texas. The APE does not include the portion of the Green Pipeline that connects the proposed new facilities in Calcasieu Parish, Louisiana and Brazoria County, Texas because it is an existing

operating pipeline and no new project-related facilities are proposed along this portion of the pipeline. The APE in Calcasieu Parish, Louisiana includes the locations of the:

- CO₂ capture and compression facilities for the Lake Charles CCS Project on the west bank of the Calcasieu River;
- LCCE Gasification plant, also on the west bank of the Calcasieu River;
- offsite facilities associated with the LCCE Gasification plant including the proposed new methanol storage area, hydrogen pipeline, water supply pipeline, natural gas pipeline, co-located transmission line, potable water line, methanol pipeline, equipment laydown area, and offsite parking area.
- 11.9-mile long CO₂ pipeline transporting CO₂ to the existing Green Pipeline; or,
- the alternative 11.6-mile long alignment for the CO₂ pipeline that connects to the existing Green Pipeline.

The APE in Texas includes the location of the West Hastings Research MVA program at the existing Hastings oil field in Brazoria County, Texas.

A number of cultural resources investigations were conducted for the various components of the project. The results of these cultural resources investigations are discussed in greater detail below in Section 3.7.3. Appendix D contains the correspondence between Leucadia or its consultants, Denbury or its consultants, DOE and the Louisiana and Texas SHPOs.

3.7.1 LCCE Gasification and Lake Charles CCS Project CO₂ Capture and Compression Facilities

Archaeological Resources

Two previously recorded archaeological sites (16CU29 and 16CU30) are located within a 0.5-mile radius of the LCCE Gasification plant and the Lake Charles CCS Project's CO₂ Capture and Compression facilities. One site, Site 16CU30, is located outside the APE. Site 16CU30 is a historic archaeological site that was previously determined eligible for listing in the NRHP because of its potential to provide information associated with historic period homesteads along the Calcasieu River (Smith et al. 2001, as cited in Handly 2009).

The second site, 16CU29, is partially located within the APE. Site 16CU29 is a prehistoric shell midden site, dating to ca. 100 B.C. to A.D. 700 (Handly 2009). The portion of Site 16CU29 that is outside the APE for the proposed action was previously determined not eligible for listing in the NRHP, but it was suggested that intact cultural materials might be represented in the portion of the site that is within the APE, and additional testing was recommended to determine the NRHP-eligibility status of this portion of the site (Smith et al. 2001, as cited in Handly 2009).

In June 2009, URS Corporation conducted a field assessment of the portion of Site 16CU29 located within the APE (see Appendix D). The purpose of the field assessment was to evaluate the NRHP-eligibility of the portion of the site within the APE (Handly 2009).

Results of the field assessment indicated that the area in the vicinity of the archaeological site appeared "to have been heavily impacted by storm surge associated with Hurricanes Rita (in 2005) and Ike (in 2008), as represented by the significant amount of debris that was deposited in the project area" (Handly 2009). Evidence of the extensive shell midden that once comprised the

portion of the site outside the APE was not observed, and it appears “that the shell midden noted in 2001 has been eroded and/or redeposited from ... Site 16CU29 (possibly as a result of hurricane storm surges over that last four years)” (Handly 2009).

While the portion of Site 16CU29 within the APE was located again during the field assessment, the integrity of the site appeared to have changed since the 2001 recommendations for additional testing to determine NRHP-eligibility. The “intensive subsurface testing program suggests that the site has been disturbed and displays very low artifact densities” and that this indicated “that Site 16CU29 lacks depositional integrity and has limited research value” (Handly 2009).

Based on the results of the field assessment, URS recommended “that Site 16CU29 does not possess those qualities of significance as identified by the National Register Criteria for Evaluation (36 CFR 60.4[a-d]); that the site should not be considered eligible for listing in the NRHP and that no additional assessment of the site is warranted” (Handly 2009). The Louisiana SHPO concurred that Site 16CU29 was not NRHP-eligible and that no further investigations were necessary (Hutcheson 2009).

In March and May 2012, URS Corporation conducted Phase IA cultural resources investigations within the APE for offsite activities associated with the LCCE Gasification plant, including the raw water, potable water, hydrogen, natural gas, and methanol and sulfuric acid pipelines, the electric transmission line, and the construction parking area (see Appendix D). The purpose of the Phase IA investigations was to identify previously recorded cultural resources within the APE for these offsite facilities and determine the need for additional cultural resources investigations within the APE for these offsite facilities (Handly 2012; URS 2012).

Results of the Phase I cultural resources investigations within the APE for the offsite facilities identified ten previously recorded cultural resources, all archaeological sites, within 0.5 miles of the APE for the offsite facilities. Of these, five were previously recommended NRHP-eligible: one late 19th to early 20th century historic archaeological site (Site 16CU30) and four prehistoric shell midden sites (sites 16CU195, 16CU198, 16CU200 and 16CU 201) dating from AD 500 to 1100). None of these previously recorded cultural resources or historic properties was identified within the APE for the off-site facilities (Handly 2012, URS 2012).

In August 2012, DOE submitted the reports for the Phase IA cultural resources investigations within the APE for the offsite facilities as associated with the LCCE Gasification plant to the Louisiana SHPO for review and comment (Fayish 2012). In January 2013, the Louisiana SHPO reviewed the Phase IA cultural resources investigations within the APE for the off-site facilities as associated with the LCCE Gasification plant and concurred with the conclusions and recommendations of the report, including: the definition of the APE for the offsite facilities; the determination of areas with high, low and no probability for containing archaeological resources; and the conclusion that previously surveyed areas or areas that have been identified as disturbed areas do not require any further investigation. The Louisiana SHPO recommended that areas determined to have a high probability for the presence of archaeological resources should be tested according to the Louisiana SHPOs archaeological investigation standards for high probability areas (e.g., systematic shovel testing at 30 meter intervals) and all other areas (i.e., areas of moderate or low probability) should be tested according to the Louisiana SHPO’s archaeological investigation standards for low probability areas (e.g., systematic shovel testing at 50 meter intervals (Breux 2013).

Historic Resources

No previously identified architectural resources listed or determined eligible for listing in the NRHP, including National Historic Landmarks (NHLs), are located within the APE (NPS 2011a, 2011b; NRHP 2011). In addition, no standing structures or historic districts occur within the APE (LA CRT 2011). The cultural resources investigations conducted for the LCCE Gasification and Lake Charles CCS Project CO₂ Capture and Compression Facilities to date also have not identified any architectural resources within the APE (Handly 2009, 2012; URS 2012).

The Louisiana SHPO reviewed the results of cultural resources investigations for the LCCE Gasification plant and the Lake Charles CCS project CO₂ Capture and Compression facilities and concurred that no further cultural resources investigations were necessary within these portions of the APE (Hutcheson 2009).

In August 2012, DOE submitted the reports for the Phase IA cultural resources investigations within the APE for the offsite facilities as associated with the LCCE Gasification plant to the Louisiana SHPO for review and comment (Fayish 2012). To date, DOE received no response from the Louisiana SHPO regarding the Phase IA cultural resources investigations within the APE for the offsite facilities as associated with the LCCE Gasification plant.

Native American Resources

In August 2012, DOE initiated consultation with 13 federally recognized Native American tribes to identify Native American resources within the APE for the LCCE Gasification plant and Lake Charles CCS CO₂ Capture and Compression facilities (see Appendix D). In December 2012, the Choctaw Nation requested results of the archaeological site file search for the immediate area and any relevant cultural resources survey reports, as well as copies of State Historic Preservation Officer (SHPO) comments, which DOE provided (Thompson 2012, Fayish 2013). In March 2013, the Choctaw Nation requested additional information regarding Site 16CU29 (Thompson 2013).

3.7.2 CO₂ Pipeline

Archaeological Resources

Six previously recorded historic archaeological sites (16CU23, 16CU29, 16CU30, 16CU172, 16CU198, and 16CU201) are located within a 0.5-mile radius of the CO₂ Pipeline. All of these six sites are located outside the APE for the CO₂ pipeline (Watkins and Futato 2011).

Between April and September 2011, the University of Alabama's Office of Archaeological Research conducted a Phase I cultural resources investigation of the APE, including the pipeline corridor, three temporary work areas and eight access roads (see Appendix D). The purpose of the Phase I cultural resources investigation was to locate and identify any archaeological sites within the APE for the CO₂ pipeline; assess their significance; and provide recommendations for NRHP-eligibility (Watkins and Futato 2011).

One archaeological site, 16CU73 was identified during the Phase I cultural resources investigation within the APE for the CO₂ pipeline. Site 16CU73 is a sparse subsurface scatter of mid-20th century artifacts. The analysis of artifacts and the absence of structural remains suggest that the site represents a refuse scatter or trash dump and may be associated with a

nearby abandoned house and outbuilding that appear to date to the 1930s or 1940s. The University of Alabama's Office of Archaeological Research indicated that further testing of the site is not likely to yield further information about the site or the history of the area.

Based on the results of the Phase I archaeological investigation of Site 16CU73, the University of Alabama's Office of Archaeological Research recommended that the site was not NRHP-eligible and that no further investigation was needed (Watkins and Futato 2011). The Louisiana SHPO reviewed the results of the Phase I cultural resources survey within the APE for the CO₂ pipeline and concurred that Site 16CU73 was not eligible for the NRHP (Breux 2012).

Historic Resources

No previously identified historic properties that are listed on the NRHP, including NHLs, are located within the APE of the pipeline corridor (NPS 2011a, 2011b; NRHP 2011). In addition, no standing structures or historic districts were identified (LA CRT 2011).

Between April and September 2011, the University of Alabama's Office of Archaeological Research conducted a Phase I cultural resources investigation of the APE, including the pipeline corridor, three temporary work areas, and eight access roads (see Appendix D). The purpose of the Phase I cultural resources investigation was to locate and identify any cultural resources within the APE; assess their significance; and provide recommendations for NRHP-eligibility (Watkins and Futato 2011).

One cultural resource, the Hardey Family Cemetery, was identified during the Phase I cultural resources investigation within the APE for the CO₂ pipeline. The Hardey Family Cemetery is a small modern cemetery established in 1988 and has two interments (Watkins and Futato 2011). As currently designed, the proposed alignment of the CO₂ pipeline will cross the Hardey Family Cemetery. The Louisiana SHPO reviewed the results of the Phase I cultural resources survey and concurred that if the proposed CO₂ pipeline was directionally drilled beneath the Hardey Family Cemetery, no historic properties would be impacted by the proposed CO₂ pipeline and no further work would be necessary for the CO₂ Pipeline (Breux 2012).

Native American Tribes

In August 2012, DOE initiated consultation with 13 federally recognized Native American tribes to identify Native American resources within the APE for the LCCE Gasification plant and Lake Charles CCS project including the CO₂ pipeline (see Appendix D). In December 2012, the Choctaw Nation requested results of the archaeological site file search for the immediate area and any relevant cultural resources survey reports, as well as copies of State Historic Preservation Officer (SHPO) comments, which DOE provided (Thompson 2012, Fayish 2013). In March 2013, the Choctaw Nation requested additional information regarding Site 16CU29 (Thompson 2013).

3.7.3 West Hastings Research MVA

Archaeological Resources

In October 2011, WSA conducted a cultural resources sensitivity assessment of the APE for the West Hastings research MVA, consisting of records and literature search, to determine whether previously identified archaeological resources were present within the APE; determine the extent of previous and existing disturbance and development within the APE; and evaluate the potential

sensitivity of the APE for unidentified archaeological resources. The results of the records and literature search by WSA indicated that there are no recorded archaeological sites, cemeteries, NRHP properties, State Archaeological Landmarks (SALs), or historical markers within the APE for the West Hastings research MVA. Because the Hastings oil field is a highly disturbed landscape due to decades of exploration and production for oil and is characterized by the presence of numerous oil pipelines, wells, and support infrastructure, WSA concluded that the potential for intact undisturbed soil profiles with archaeological sensitivity within the APE was limited, if not entirely absent (Karbula 2011).

As a result of the records and literature search, WSA concluded that the APE for the West Hastings research MVA had a low probability for containing NRHP-eligible historic properties in the APE and that no archeological survey of the West Hastings research MVA area was needed (Karbula 2011). The Texas SHPO reviewed the report for the cultural resources sensitivity assessment of the APE for the research MVA, concurred with the conclusions of the report, and indicated that the research MVA portion of the proposed project could proceed without further consultation with the Texas SHPO, provided that no significant archaeological deposits were encountered during development activities within the APE (Wolfe 2011). Since the research MVA activities are jointly conducted with Leucadia and Air Products, it should be noted that a similar conclusion was documented for the Air Products project. (APCI 2011)

Historic Resources

No previously identified architectural resources that are listed in the NRHP, including NHLs, were located within the APE for the West Hastings research MVA (NPS 2011a, 2011b; NRHP 2011). In addition, no neighborhood surveys, historical markers, NRHP properties or districts, cemeteries, museums, historic county courthouses, military sites, or buildings that are SALs were identified within the APE (THC 2011). The cultural resources sensitivity assessment conducted for the APE did not identify any architectural resources within the APE (Karbula 2011). The Texas SHPO reviewed the report for the cultural resources sensitivity assessment of the APE for the West Hastings research MVA, concurred with the conclusions of the report, and did not indicate any concerns regarding architectural resources (Wolfe 2011).

Native American Tribes

August 2012, DOE initiated consultation with 13 federally recognized Native American tribes to identify Native American resources within the APE for the LCCE Gasification and Lake Charles CCS project including the West Hastings research MVA location (see Appendix D). In December 2012, the Choctaw Nation requested information for the LCCE Gasification site, which DOE provided (Thompson 2012, Fayish 2013). To date, DOE received no responses from these tribes with respect to the West Hastings research MVA site.

3.8 Land Use

3.8.1 LCCE Gasification Plant and Lake Charles CCS CO₂ Capture and Compression Facilities

The proposed LCCE Gasification plant and Lake Charles CCS CO₂ Capture and Compression facilities would be located on a 70-acre site in central Calcasieu Parish, Louisiana, along the right descending bank of the Calcasieu River and southwest of the Lake Charles Harbor and Terminal District. Land use in the site vicinity is predominantly wetlands and developed areas, including heavy industrial and petrochemical development as shown in Figure 3.8-1. Land use

within a 1-mile radius consists primarily of herbaceous wetlands, open water associated with the Calcasieu River, high-intensity development, and woody wetlands as summarized in Table 3.8-1.

The CO₂ Capture and Compression facilities would be located within the property of the LCCE Gasification plant site, which is cleared and currently under development. Each of the two AGR units would occupy an area of approximately 500 feet by 300 feet. Each of the two compression buildings would occupy an area of approximately 80 feet by 140 feet. No additional land would be used or disturbed outside of the project site for construction of the CO₂ Capture and Compression facilities. All land within the LCCE Gasification plant site is zoned for heavy industrial use. The existing Bayou D'Inde Road would be used during construction and operation to provide access to the CO₂ Capture and Compression facilities.

Off-site activities associated with the LCCE Gasification plant included within the 1-mile radius evaluated above include the equipment laydown area, methanol and sulfuric acid storage area, methanol and sulfuric acid pipeline linears and utilities. The proposed raw water pipeline would include approximately 4 miles of 50-foot-wide permanent pipeline ROW. The proposed hydrogen pipeline would include approximately 8.5 miles of 50-foot-wide permanent ROW. The proposed routes parallel existing ROWs (transmission lines, roads, pipelines, railroads, and other linear features) to the extent practicable. The USGS National Land Cover Dataset (2006) identifies land use crossed by the proposed pipeline routes. Table 3.8-2 summarizes land uses within a 1-mile buffer along the routes.

Table 3.8-1 Land Use within a 1-Mile Radius of the LCCE Gasification Plant and Lake Charles CCS Project¹

Land Use Type	Area (acres)
Open water	430.85
Developed, open space	38.28
Developed, low intensity	221.72
Developed, medium intensity	140.60
Developed, high intensity	253.13
Barren Land, rock/sand/clay	4.00
Evergreen Forest	9.15
Mixed Forest	0.03
Shrub/scrub	0
Grassland/herbaceous	0
Pasture/hay	1.68
Cultivated crops	0
Woody wetlands	448.89
Emergent herbaceous wetlands	462.14
Total	2,010.46

¹ Acreage totals are based on the assumption of a 1 mile radius from the center of the LCCE Gasification plant and land cover values from the USGS 2006 NCLD (Fry et al. 2011).

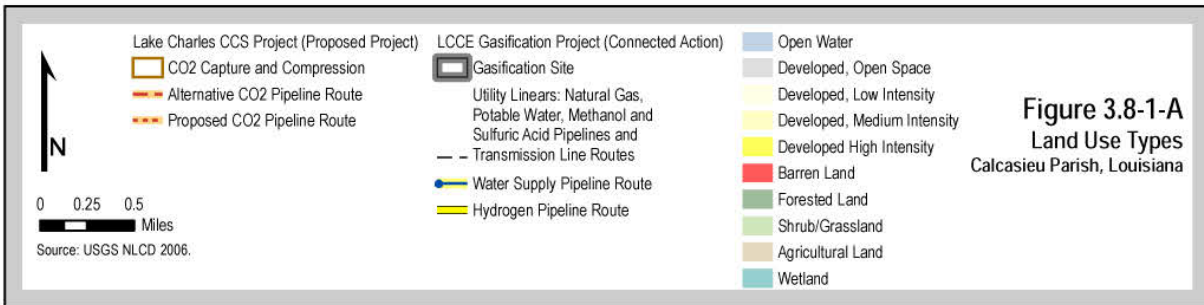
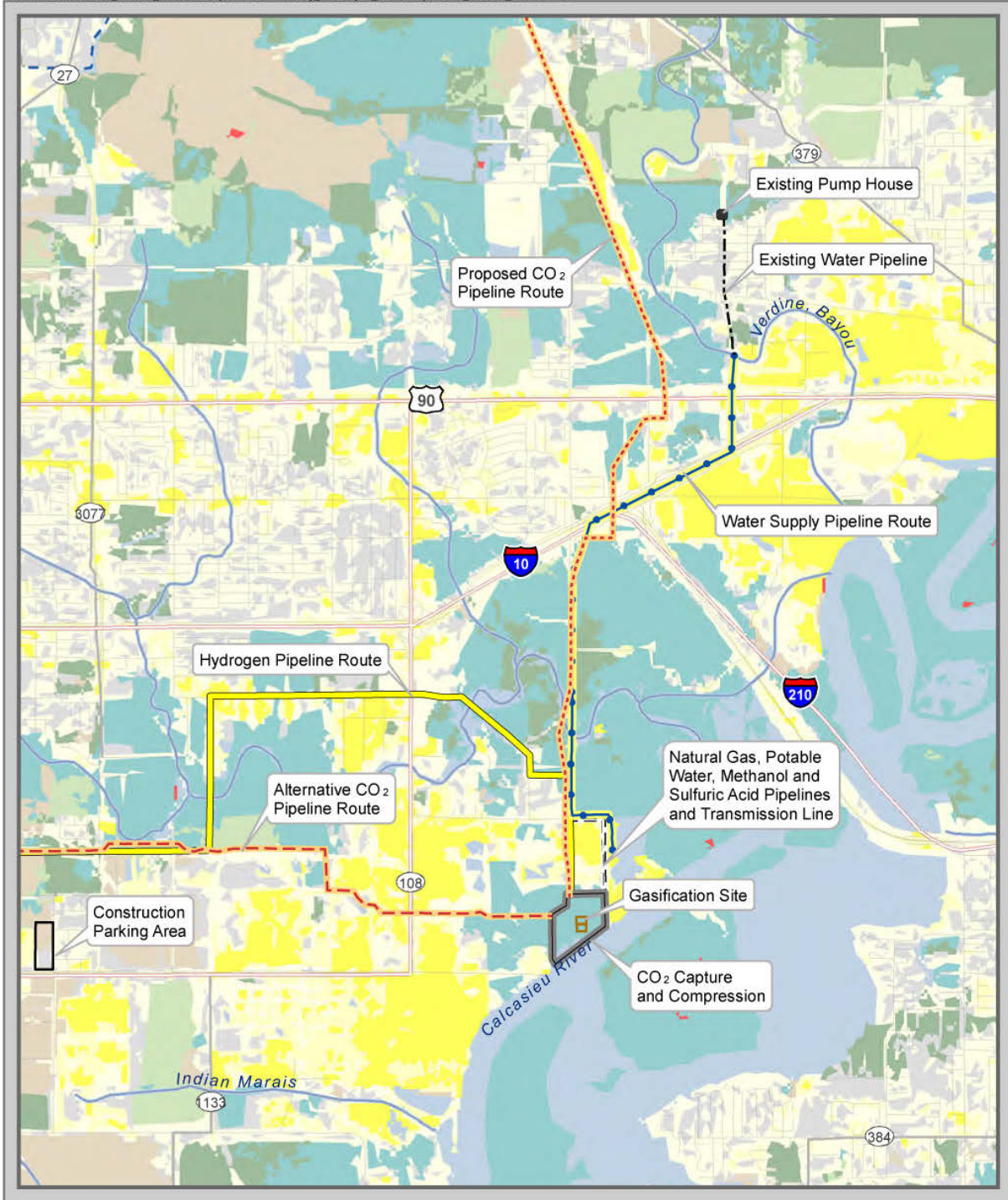

This page left blank intentionally.

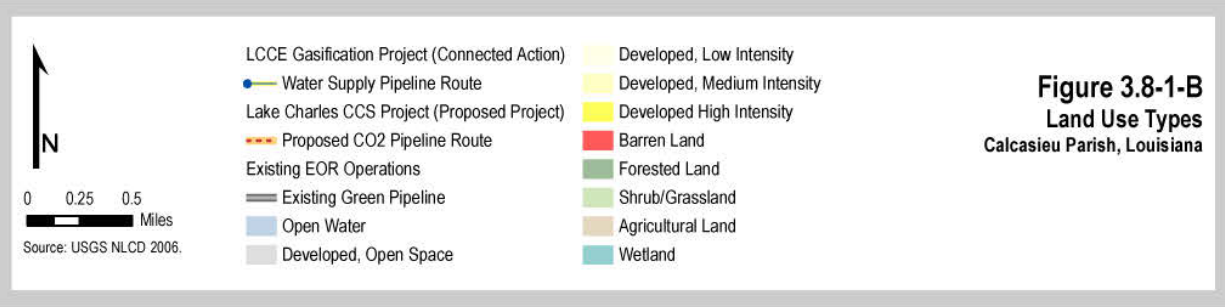
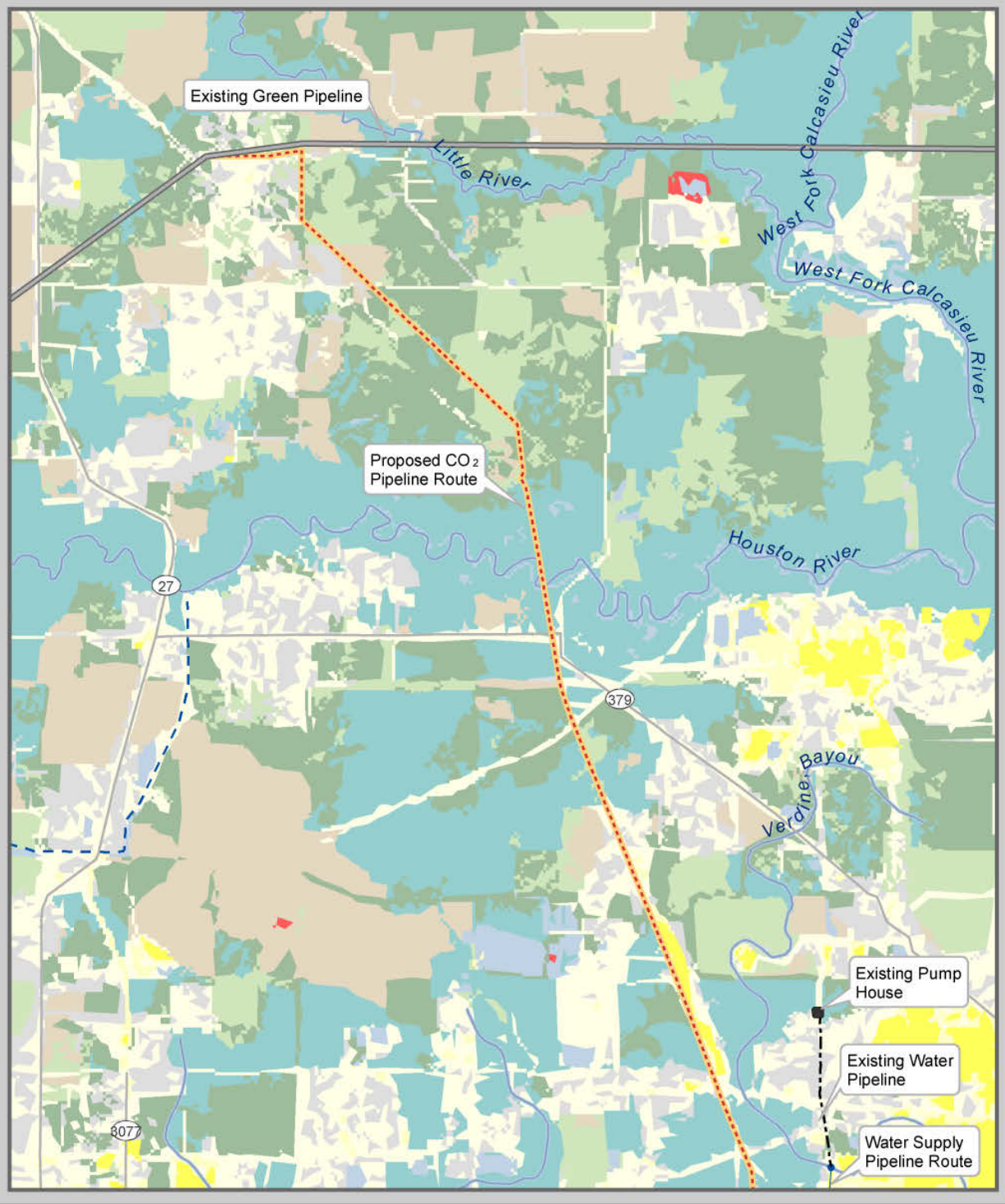

This page left blank intentionally.

Table 3.8-2 Land Use within a 1-Mile Buffer along the Water Supply and Hydrogen Pipelines¹

Land Cover Type	Water Supply Pipeline (acres)	Hydrogen Pipeline (acres)
Open Water	160.2	289.4
Developed, Open Space	149.5	615.8
Developed, low intensity	675.3	1,237.1
Developed, medium intensity	292.3	331.8
Developed, high intensity	394.5	261.4
Barren Land, rock/sand/clay	0.00	1.1
Deciduous forest	15.3	7.4
Evergreen Forest	152.8	360.2
Mixed Forest	2.2	38.9
Shrub/Scrub	0.00	151.0
Grassland/Herbaceous	5.1	40.0
Pasture/Hay	0.2	461.3
Cultivated crops	0.00	98.8
Woody Wetlands	877.9	1,712.8
Emergent Herbaceous Wetlands	262.9	118.5
Total	2,988.2	5,725.5

¹ Acreage totals are based on the assumption of a ½ mile buffer on either side of the pipeline centerline and land cover values from USGS 2006 NLCD (Fry et al. 2011).

Additional workspace areas and construction and storage yards would be located along the permanent pipeline ROW during construction and subsequent operation and maintenance. Leucadia would develop the specific location of temporary workspaces during detailed design.

Residential and Commercial Properties

The closest identified residences are approximately 0.75 miles north of the site. Areas within the city of Lake Charles zoned for residential development are located approximately 1.2 to 1.8 miles to the east and southeast, across the Calcasieu River and Prien Lake.

The proposed water supply pipeline route crosses two railroads and three roads (including interstate highways, U.S. highways, and state highways). The proposed hydrogen pipeline route crosses one railroad, 10 roads (including interstate highways, U.S. highways, and state highways), and 1 known pipeline. The majority of the pipeline routes would be adjacent to existing ROWs for linear features such as railroads, canals, roadways, transmission lines, and other pipelines.

No national parks, national wildlife refuges, publicly owned lands, or recreational areas are located within 1 mile of the proposed water supply or hydrogen pipelines (NPS 2011; USFWS 2011; LSLO 2011; USDA 2011). The proposed pipeline route does not cross any National Wild and Scenic Rivers designated by the Wild and Scenic Rivers Council (WSRC) (WSRC 2010) or State of Louisiana-designated Natural and Scenic Rivers (LDWF 2011). The pipeline routes do not cross public lands or other protected natural areas. The proposed routes do not cross any designated scenic highways (National Scenic Byways Program 2010).

CO₂ Pipeline Route

Large population areas within the 50-mile (80-km) region of influence (ROI) of the proposed CO₂ pipeline include the cities of Lake Charles and Lafayette, Louisiana, and Beaumont and Port Arthur, Texas. Smaller cities and communities immediately surrounding the project site include Sulphur, Prien, and Iowa, Louisiana.

The proposed CO₂ pipeline would include approximately 11.9 miles of 50-foot-wide permanent pipeline ROW. Land use primarily includes developed industrial and residential areas, evergreen forest, and woody wetland areas. The proposed route parallels existing ROWs (transmission lines, roads, pipelines, railroads, and other linear features) to the extent practicable.

DOE used the USGS National Land Cover Dataset (2006) to identify land use for areas crossed by the proposed pipeline route. Table 3.8-3 lists land uses within a 1-mile buffer along the CO₂ pipeline corridor.

Additional workspace areas and construction and storage yards would be located along the permanent pipeline ROW during construction and subsequent operation and maintenance. Construction activities for the proposed project would require two construction/storage yards of approximately 5 acres and 8 acres, and a temporary office. Denbury would develop the specific location of temporary workspaces during detailed design. The 1 mile buffer area described above would include these areas.

Table 3.8-3 Land Use within a 1-Mile-Wide Buffer along the CO₂ Pipeline¹

Land Use Type	Acres
Open water	244.9
Developed, open space	444.6
Developed, low intensity	1,399.3
Developed, medium intensity	244.3
Developed, high intensity	189.2
Evergreen forest	1,323.6
Mixed forest	42.1
Shrub/scrub	562
Grassland/herbaceous	174.4
Pasture/hay	217.6
Cultivated crops	62.8
Woody wetlands	2,288
Emergent herbaceous wetlands	287.6
Total	7,474.2

¹ Acreage totals are based on the assumption of a ½ mile buffer on either side of the pipeline centerline and land cover values from USGS 2006 NLCD (Fry et al. 2011).

Residential and Commercial

The proposed CO₂ pipeline is located in a rural, sparsely populated area including eight residences within 50 feet of the ROW (see Table 3.8-4). According to the Calcasieu Parish Planning and Development Department, the proposed project is compatible with Calcasieu Parish’s future land use plan and comprehensive plan (Wallace 2011).

Table 3.8-4 Residences within 50 feet of the Construction Workspace of the Proposed CO₂ Pipeline

Residence	MP	Distance to ROW	Direction
Residence 1	4.3	45 feet	Northeast
Residence 2	5.5	40 feet	Northeast
Residence 3	5.5	40 feet	Northeast
Residence 4	5.5	38 feet	Northeast
Residence 5	5.6	48 feet	Northeast
Residence 6	10.3	35 feet	East
Residence 7	10.4	50 feet	East
Residence 8	10.8	50 feet	North

Source: CH2M Hill 2011.

Utility Crossing

The proposed CO₂ pipeline route crosses six railroads, 19 roads (including interstate highways, U.S. highways, and state highways), eight transmission lines, and no known pipelines. The majority of the pipeline route would be adjacent to existing ROWs for linear features such as railroads, canals, roadways, transmission lines, and other pipelines.

No national parks, national wildlife refuges, publicly owned lands, or recreational areas are located within 1 mile of the proposed pipeline (NPS 2011; USFWS 2011; LSLO 2011; USDA 2011). The proposed pipeline route does not cross any National Wild and Scenic Rivers designated by the Wild and Scenic Rivers Council (WSRC) (WSRC 2010) or State of Louisiana-designated Natural and Scenic Rivers (LDWF 2011). The pipeline route does not cross public lands or other protected natural areas. The proposed pipeline route does not cross any designated scenic highways (National Scenic Byways Program 2010).

3.8.2 Hastings Oil Field, Texas

The proposed West Hastings research MVA site is located in the northeast corner of Brazoria County, Texas, within the Hastings oil field. The Hastings oil field occupies a 25-square-mile area located between Pearland and Alvin, Texas. Land uses within the Hastings oil field include farmland, rural development, and recreational, commercial, and residential areas. The West Hastings research MVA activities would occur within a 2.8-square-mile portion of the Hastings oil field, along State Highway 35. The area contains approximately 80 active, 100 inactive, and 110 P&A wells, as well as a number of temporarily abandoned (TA) wells. The West Hastings research MVA activities would be consistent with existing and future commercial oil and gas operations in the area.

The USGS National Land Cover Dataset (2006) identifies land uses within the 2.8-square-mile site as primarily dedicated hay pasture and developed open space, as shown in Figure 3.8-2. In addition, areas of low-intensity development, cultivated crops, and shrub/grasslands occur within the 2.8-square-mile site, along with pockets of deciduous forest and wetlands. Developed land uses are concentrated along State Highway 35. An extensive network of large oil and gas pipelines exists in this part of the Texas North Gulf Coastal area and many run within a few miles of the project area. BP Pipelines, Conoco Phillips, Enterprise Products, Exxon Mobil GGS, Kinder Morgan, Tejas, Texas Eastern Transmission, TexCal Energy, and several others own and operate pipelines in the Hastings oil field. A large network of smaller gathering

pipelines also services the existing well sites in the Hastings Field. In addition, high- and low-pressure gas collection lines, production water and saltwater lines, and power lines service the area.

A spur of the Burlington Northern (Atchison Topeka and Santa Fe) Railroad intersects the project area to the west. A large high-power transmission line is located southwest of the project site.

3.9 Socioeconomics and Environmental Justice

3.9.1 Socioeconomics

This section describes the existing social and economic characteristics of the City of Sulphur, Calcasieu Parish and Brazoria County, Texas. The proposed LCCE Gasification plant and Lake Charles CCS Capture and Compression facilities and associated offsite activities would be located in the City of Sulphur and Calcasieu Parish, Louisiana. The proposed CO₂ pipeline would be located within the City of Sulphur and Calcasieu Parish, Louisiana and is within the areas described below for the LCCE Gasification plant. The proposed West Hastings research MVA site is located between the cities of Alvin and Pearland in Brazoria County, Texas.

3.9.1.1 Population and Housing

Calcasieu Parish, Louisiana

Table 3.9-1 shows the population levels, recent growth rates, and population density statistics (i.e., persons per square mile) in 2000 and 2010 for the communities potentially impacted by the proposed LCCE Gasification plant and Lake Charles CO₂ Capture and Compression facilities and CO₂ Pipeline. Based on data from the 2000 and 2010 U.S. Censuses, the population of the city of Sulphur, Louisiana, decreased by approximately 0.5%, or 0.05% per year. In contrast, the total population of Calcasieu Parish as a whole grew by approximately 5.0% during the past decade, or 0.5% per year; and the total population of the State of Louisiana grew by 1.4% between 2000 and 2010, or 0.14% per year.

Table 3.9-1 Historic and Current Population (2000, 2010)

Geographic Area	Year	Total Population	Percent Change (2000-2010)	Population Density	Land Area (square miles)
State of Louisiana	2000	4,468,976	-	102.6	43,561.85
	2010	4,533,372	1.4	104.1	
Calcasieu Parish	2000	183,577	-	171.4	1,071.12
	2010	192,768	5.0	180.0	
City of Sulphur	2000	20,512	-	2,043.0	10.04
	2010	20,410	(0.5)	2,032.9	

Source: USCB 2000, 2010.

With a population density of approximately 2,033 persons per square mile, the city of Sulphur is significantly denser than its corresponding parish and state. The population density in Calcasieu Parish is approximately 180 persons per square mile, while the population density in the State of Louisiana is approximately 104 persons per square mile.

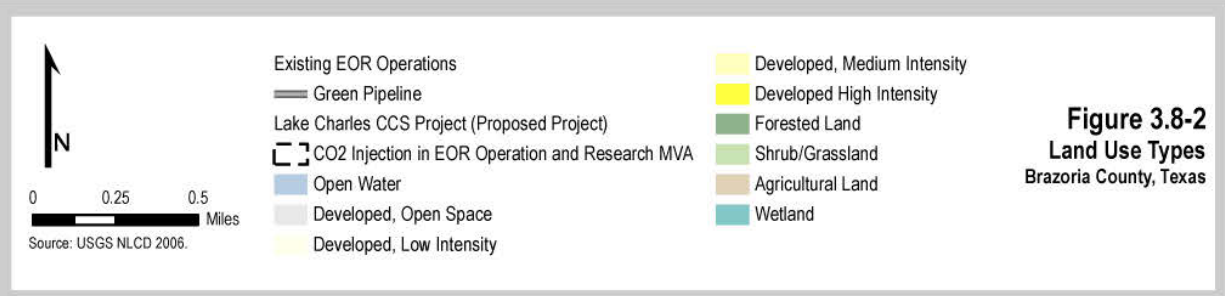
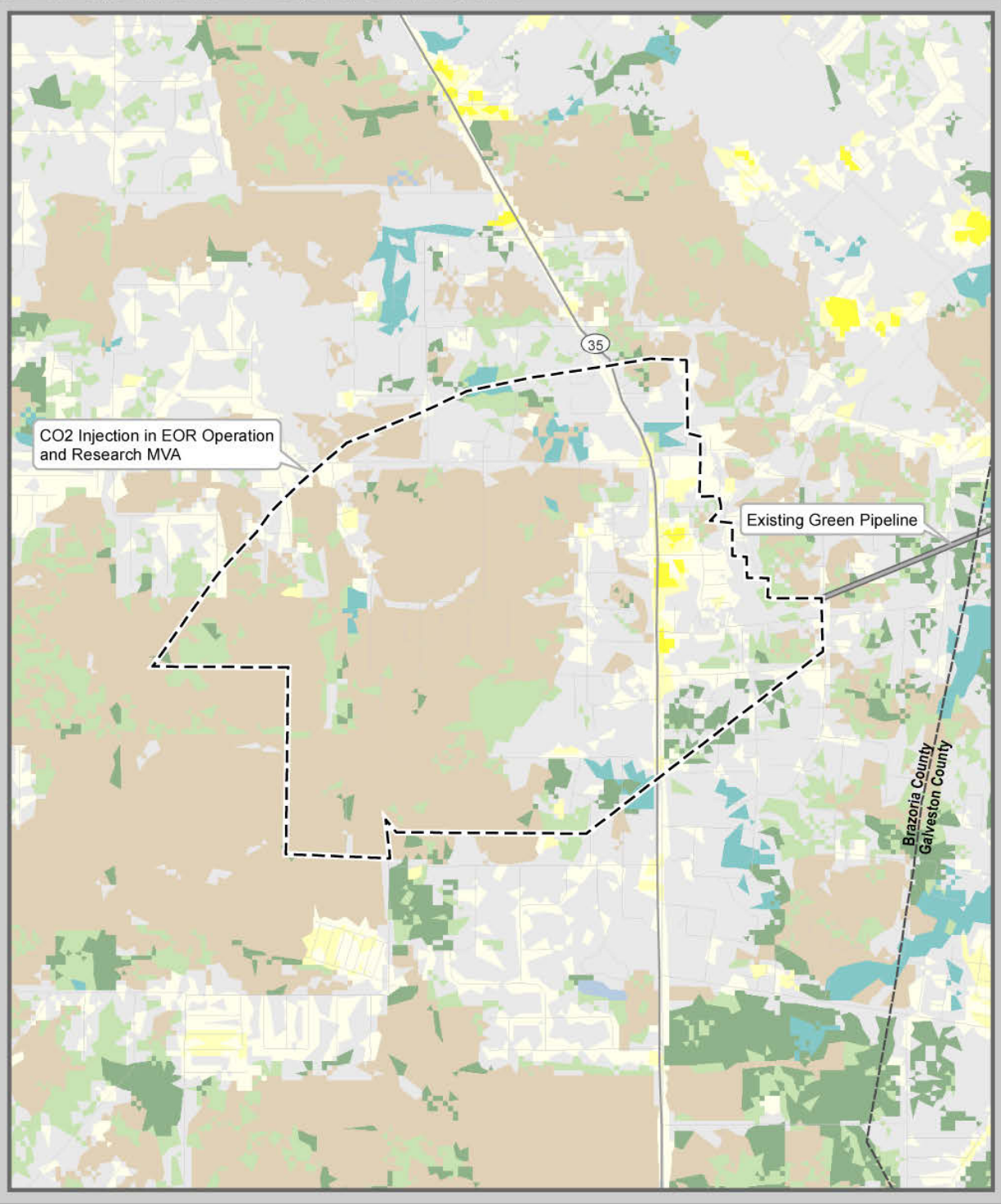

This page left blank intentionally.

The housing stock in the city of Sulphur, Calcasieu Parish, and the State of Louisiana experienced some growth over the past decade. As shown in Table 3.9-2, the stock number of housing units in the city of Sulphur increased by approximately 4.5% from 2000 to 2010. In comparison, the total housing stock in Calcasieu Parish increased by approximately 8.0%, and the total housing stock in the State of Louisiana increased by approximately 6.4% during the same period.

Table 3.9-2 Total Housing Units (2000, 2010)

Geographic Area	Total Housing Units (2000)	Total Housing Units (2010)	Percent Change (2000-2010)
State of Louisiana	1,847,181	1,964,981	6.4
Calcasieu Parish	75,995	82,058	8.0
City of Sulphur	8,665	9,053	4.5

Source: USCB 2000, 2010.

Table 3.9-3 shows the 2010 occupancy and vacancy statistics for housing stock in the city of Sulphur, Calcasieu Parish, and the State of Louisiana. The city of Sulphur housing rates are similar to owner-occupied housing rates in Calcasieu Parish and the State of Louisiana. In 2010, the city of Sulphur had a homeowner vacancy rate and a rental vacancy rate slightly greater than the parish wide rates.

Table 3.9-3 Detailed Housing Statistics

Geographic Area	Total Housing Units	Occupied Units			Vacant Units		
		Total	Owner Occupied	Renter Occupied	Total	Homeowner Vacancy Rate	Rental Vacancy Rate
State of Louisiana	1,964,981	1,728,360	1,162,299	566,061	236,621	1.8%	10.5%
Calcasieu Parish	82,058	73,996	51,533	22,463	8,062	1.4%	11.6%
City of Sulphur	9,053	8,099	5,484	2,615	954	1.6%	15.7%

Source: USCB 2010.

Brazoria County, Texas

The West Hastings research MVA would occur between the cities of Alvin and Pearland, in Brazoria County, Texas. Table 3.9-4 shows the population levels, recent growth rates, and population density statistics (i.e., persons per square mile) in 2000 and 2010 for these communities. Based on the 2000 and 2010 U.S. Censuses, the total population in these areas increased significantly in the past decade. Rapid population growth has occurred throughout the region, with the city of Pearland experiencing the most dramatic increase in its total population.

Table 3.9-4 also shows population densities in the various geographic areas in the affected region. With respective population densities of approximately 1,475 and 2,320 persons per square mile, the cities of Alvin and Pearland are significantly more densely populated than the county or state (USCB 2010).

Table 3.9-4 Historic and Current Population (2000, 2010)

Geographic Area	Year	Total Population	Percent Change (2000-2010)	Population Density (persons per square mile)	Land Area (square miles)
City of Alvin	2000	21,413	-	1,303.3	16.43
	2010	24,236	13.2	1,475.1	
City of Pearland	2000	37,640	-	957.0	39.33
	2010	91,252	142.4	2,320.2	
Brazoria County	2000	241,767	-	174.4	1,386.40
	2010	313,166	29.5	225.9	
State of Texas	2000	20,851,820	-	79.6	261,797.12
	2010	25,145,561	20.6	96.0	

Source: USCB 2000, 2010.

According to data collected by the U.S. Census Bureau, the region has experienced significant growth in its housing stock from 2000 to 2010. As shown in Table 3.9-5, the total number of housing units increased by approximately 14.3% in the city of Alvin from 2000 to 2010 (USCB 2000, 2010). However, this level of growth is relatively marginal when compared to Brazoria County and the State of Texas as a whole.

Table 3.9-5 Total Housing Units (2000, 2010)

	Total Housing Units (2000)	Total Housing Units (2010)	Percent Change (2000-2010)
State of Texas	8,157,575	9,977,436	22.3
Brazoria County	90,628	118,336	30.6
City of Alvin	8,442	9,645	14.3
City of Pearland	13,922	33,169	138.2

Source: USCB 2000, 2010.

Table 3.9-6 shows 2010 occupancy and vacancy statistics for the city of Alvin, the city of Pearland, Brazoria County, and the State of Texas. Relatively fewer housing units are owner-occupied in the city of Alvin than in Brazoria County and the State of Texas as a whole. In contrast, there are relatively more owner-occupied housing units in the city of Pearland than in the county and state. The area experienced low homeowner vacancy rates.

Table 3.9-6 Detailed Housing Statistics

Geography	Total Housing Units	Occupied Units			Vacant Units		
		Total	Owner Occupied	Renter Occupied	Total	Homeowner Vacancy Rate	Rental Vacancy Rate
State of Texas	9,977,436	8,922,933	5,685,353	3,237,580	1,054,503	2.1%	10.8%
Brazoria County	118,336	106,589	79,477	27,112	11,747	2.1%	13.4%
City of Alvin	9,645	8,742	4,978	3,764	903	2.3%	11.2%
City of Pearland	33,169	31,222	24,861	6,361	1,947	2.1%	12.2%

Source: USCB 2010.

3.9.1.2 Economy and Employment

Calcasieu Parish, Louisiana

The economy of Calcasieu Parish and much of southwestern Louisiana revolves around the chemical and oil refining industries. The location of the Port of Lake Charles, with its proximity to the Gulf of Mexico, is an important economic stimulus in the area. Casinos and other entertainment venues also are large employers in the region.

Table 3.9-7 presents total employment by industry sector for the city of Sulphur, Calcasieu Parish, and the State of Louisiana. The largest employment sectors in the city of Sulphur are educational, health, and social services (20.8%) and construction (16.6%) (USCB 2009). Educational, health, and social services also represents the largest employment sector in Calcasieu Parish (21.1%) and the State of Louisiana (22.5%).

Table 3.9-7 Employment by Sector (2009)

Sector	City of Sulphur		Calcasieu Parish		State of Louisiana	
	Total Employment	Employment as a % of Total	Total Employment	Employment as a % of Total	Total Employment	Employment as a % of Total
Agriculture, Forestry, Fishing, Hunting, and Mining	165	1.9%	2,268	2.7%	85,146	4.4%
Construction	1,475	16.6%	9,074	10.9%	169,537	8.8%
Manufacturing	979	11.0%	8,508	10.2%	164,376	8.5%
Wholesale Trade	257	2.9%	2,066	2.5%	61,559	3.2%
Retail Trade	985	11.1%	9,641	11.6%	232,214	12.0%
Transportation and Warehousing, Utilities	199	2.2%	4,123	4.9%	99,702	5.1%
Information	101	1.1%	1,435	1.7%	32,794	1.7%
Finance, Insurance, Real Estate, and Renting/Leasing	337	3.8%	4,022	4.8%	108,413	5.6%
Professional, Scientific, Management, Administrative, and Waste Management Services	875	9.9%	6,199	7.4%	159,691	8.2%
Educational, Health, and Social Services	1,840	20.8%	17,614	21.1%	435,577	22.5%
Arts, Entertainment, Recreation, Accommodation and Food Services	952	10.7%	10,122	12.1%	181,588	9.4%
Other services (except Public Administration)	350	3.9%	4,451	5.3%	99,479	5.1%
Public Administration	349	3.9%	3,880	4.7%	106,606	5.5%

Source: USCB 2009.

Table 3.9-8 presents labor force statistics for Calcasieu Parish and the State of Louisiana. (Data were not available from the U.S. Bureau of Labor Statistics for the city of Sulphur.)

Table 3.9-8 Annual Average Labor Force Statistics (2010)

Geography	Civilian labor force			
	Total	Employed	Unemployed	Percent Unemployed
State of Louisiana	2,081,675	1,926,492	155,183	7.5%
Calcasieu Parish	92,162	85,699	6,463	7.0%

Source: U.S. Bureau of Labor Statistics 2011.

As shown in Table 3.9-9, per capita income in the city of Sulphur was \$23,450 in 2009 (USCB 2009). This amount is similar to the per capita income in Calcasieu Parish (\$23,514) but greater than that of the State of Louisiana as a whole (\$22,535) (USCB 2009).

Table 3.9-9 Income Statistics

Geographic Area	2009 Per capita Income	2010 Median Household Income
State of Louisiana	\$22,535	\$43,362
Calcasieu Parish	\$23,514	\$43,460
City of Sulphur	\$23,450	\$45,534

Source: USCB 2009, 2011.

Brazoria County, Texas

The regional economy is strongly affected by the oil and gas and petrochemical industries and the site's proximity to Houston, Texas. Table 3.9-10 presents total employment, by industry, within the city of Alvin, the city of Pearland, Brazoria County, and the State of Texas. The city of Alvin has a fairly diversified economy, with no one sector employing more than 20% of the city's employed labor force. The largest employment sectors in the city of Alvin are educational, health, and social services (18.3%) and manufacturing (15.2%) (USCB 2009). All other sectors represent less than 15% of the city's total employed labor force. The two largest employment sectors in the city of Pearland are educational, health, and social services (26.0%) and professional, scientific, management, administrative, and waste management (13.1%). The educational, health, and social services sector also is the largest employment sector in Brazoria County (20.7%), with manufacturing being the next most important industry sector (USCB 2009).

Table 3.9-10 Employment by Sector (2009)

Sector	State of Texas		Brazoria County		City of Alvin		City of Pearland	
	Total Employed	% of Total	Total Employed	% of Total	Total Employed	% of Total	Total Employed	% of Total
Agriculture, Forestry, Fishing, Hunting, and Mining	306,509	2.8%	3,714	2.8%	261	2.5%	1,214	3.1%
Construction	979,269	9.0%	14,718	10.9%	969	9.4%	1,936	4.9%
Manufacturing	1,074,433	9.9%	18,945	14.0%	1,568	15.2%	4,081	10.3%
Wholesale Trade	377,095	3.5%	4,578	3.4%	305	3.0%	2,037	5.2%
Retail Trade	1,261,440	11.6%	13,114	9.7%	1,464	14.2%	3,825	9.7%

Table 3.9-10 Employment by Sector (2009)

Sector	State of Texas		Brazoria County		City of Alvin		City of Pearland	
	Total Employed	% of Total	Total Employed	% of Total	Total Employed	% of Total	Total Employed	% of Total
Transportation and Warehousing, Utilities	616,763	5.7%	7,082	5.3%	495	4.8%	2,259	5.7%
Information	243,574	2.2%	2,050	1.5%	342	3.3%	742	1.9%
Finance, Insurance, Real Estate, and Renting/Leasing	755,300	7.0%	6,948	5.2%	599	5.8%	2,435	6.2%
Professional, Scientific, Management, Administrative, and Waste Management Services	1,134,321	10.4%	14,192	10.5%	903	8.8%	5,166	13.1%
Educational, Health, and Social Services	2,193,568	20.2%	27,973	20.7%	1,887	18.3%	10,245	26.0%
Arts, Entertainment, Recreation, Accommodation, and Food Services	893,441	8.2%	8,555	6.3%	905	8.8%	1,911	4.8%
Other services (except Public Administration)	566,112	5.2%	6,784	5.0%	441	4.3%	1,802	4.6%
Public Administration	459,139	4.2%	6,198	4.6%	174	1.7%	1,801	4.6%

Source: USCB 2009.

Table 3.9-11 presents labor force statistics for the city of Pearland, Brazoria County, and the State of Texas. The 2010 average annual unemployment rate in the city of Pearland was lower than both the unemployment rates in Brazoria County and the State of Texas (U.S. Bureau of Labor Statistics 2011).

Table 3.9-11 Annual Average Labor Force Statistics (2010)

Geography	Civilian labor force			
	Total	Employed	Unemployed	Percent Unemployed
State of Texas	12,136,384	11,141,903	994,481	8.2
Brazoria County	148,943	135,559	13,384	9.0
City of Pearland	46,408	43,290	3,118	6.7

Source: U. S. Bureau of Labor Statistics 2011.

Note: Data was not reported by the Bureau of Labor Statistics for the city of Alvin.

As shown in Table 3.9-12, the 2009 per capita income in the city of Alvin was \$21,001, which is less than the 2009 per capita income in Brazoria County and the State of Texas (USCB 2009). In contrast, per capita income in the city of Pearland is considerably higher at \$33,984 (USCB 2009).

Table 3.9-12 Income Statistics

Geographic Area	2009 Per capita Income	2010 Median Household Income
State of Texas	\$24,318	\$49,585
Brazoria County	\$27,208	\$66,221
City of Alvin	\$21,001	\$46,260
City of Pearland	\$33,984	\$85,090

Source: USCB 2009, 2011.

3.9.1.3 Fiscal

Calcasieu Parish, Louisiana

Table 3.9-13 presents the total assessment of all property in Calcasieu Parish and the State of Louisiana for the year 2010. Excluding homestead exemptions, total assessment in Calcasieu Parish was approximately \$1.8 billion (Louisiana Tax Commission 2010). The parish accounted for nearly 4.6% of the total assessed value of property in the State of Louisiana. In recent years, total assessed value in Calcasieu Parish grew at a faster rate than in the State of Louisiana as a whole. Between 2007 and 2010, total assessed value in Calcasieu Parish increased by approximately 28.6%, while total assessed value in the State of Louisiana increased by 22.8% during the same period (Louisiana Tax Commission 2010).

Table 3.9-13 Total Assessed Value (billions) (2007, 2008, 2009, 2010)¹

	2007	2008	2009	2010
State of Louisiana	\$32.0	\$36.4	\$38.1	\$39.3
Calcasieu Parish	\$1.4	\$1.6	\$1.7	\$1.8

Source: Louisiana Tax Commission 2010.

¹ Excludes Homestead Exemption.

The millage rate is the amount per \$1,000 that is used to calculate taxes on property. The 2009 millage rate in Calcasieu Parish was \$113.1 per assessed thousand; the statewide weighted average was \$106.2 per assessed thousand (Louisiana Tax Commission 2009).

Local government revenues and expenditures for the City of Sulphur and Calcasieu Parish are shown on Tables 3.9-14 and 3.9-15. Sales tax receipts were the largest funding source for the City of Sulphur. This tax accounted for approximately, \$11.9 million of the City's \$25.8 million in total revenue in 2010, or 46%.

Public safety, which includes spending on police and fire services, was the single largest expense for the City of Sulphur during fiscal year 2010. In contrast, public works spending and spending on general government were the largest expenditure categories for Calcasieu Parish during fiscal year 2010 (See Table 3.9-15).

Table 3.9-14 Local Government Revenues (1,000s) (FY 2010)

	City of Sulphur	Calcasieu Parish
Fees, fines and charges for services	\$7,290	\$13,665
Grants and Contributions (operating and capital)	\$1,813	\$30,690
Property Taxes	-	\$32,879
Sales taxes	\$11,894	\$31,935
Gaming revenues	-	\$10,412
Other taxes, investment income and other revenues	\$4,848	\$4,273
Total	\$25,845	\$123,854

Source: City of Sulphur, Department of Finance 2010; Calcasieu Parish, Division of Finance 2010.

Table 3.9-15 Local Government Expenditures (1,000s) (FY 2010)

Categories	City of Sulphur	Calcasieu Parish
General Government	\$3,468	\$26,903
Public Safety	\$9,895	\$17,659
Public Works	-	\$39,138
Streets and Parks	\$5,291	-
Cultural and Recreation	-	\$3,228
Sanitation	-	\$5,620
Health and Welfare	-	\$13,459
Other	\$8,877	\$7,536
Total	\$27,531	\$113,543

Source: City of Sulphur, Department of Finance 2010; Calcasieu Parish, Division of Finance 2010.

Brazoria County, Texas

Brazoria County and the cities of Alvin and Pearland all generate revenues through a tax on real property. The total taxable assessed value in 2010 in the county and cities is shown in Table 3.9-16.

Table 3.9-16 Total Taxable Assessed Value and Property Tax Rates (2010)

Geographic Area	Total Taxable Assessed Value (in millions)	Property Tax Rate (expressed as \$/1,000 of assessed value)
Brazoria County	\$11,738	\$4.26286
City of Alvin	\$922	\$8.03600
City of Pearland	\$484	\$6.65100

Source: Brazoria County 2011; City of Alvin 2011; City of Pearland 2011.

Local government revenues and expenditures for the cities of Alvin and Pearland and Brazoria County are shown on Table 3.9-17 and 3.9-18. Property taxes were the largest single revenue source for Brazoria County. Expenditures on public transportation (19.5%), corrections (16.5%), and public safety (12.3%) accounted for nearly half of all of Brazoria County's expenses in 2010. Public safety and water and sewer expenditures were the largest single expenses for the City of Alvin during the same period. Water and sewer, public safety, and public services/works were the largest expenditures for the City of Pearland during FY 2010.

Table 3.9-17 Local Government Revenues, by Source, for Fiscal Year Ending Sept. 30, 2010 (in 1,000s)

Source	Brazoria County	City of Alvin	City of Pearland
Property Taxes	\$86,026	\$7,529	\$32,963
Sales and Use Taxes	\$15,539	\$5,165	\$13,578
Charges for Services	\$21,774	\$11,275	\$40,798
Grants and Contributions	\$31,354	\$715	\$45,225
Other Taxes	0	\$1,823	\$5,426
Other Revenue Sources	\$2,589	\$288	\$2,160
Total	\$157,282	\$26,795	\$140,150

Source: Brazoria County 2011; City of Alvin 2011; City of Pearland 2011.

Table 3.9-18 Local Government Expenditures, by Expense, for Fiscal Year Ending September 30, 2011 (in 1,000s)

Expense	Brazoria County	City of Alvin	City of Pearland
General Government	\$9,795	\$3,398	\$13,439
Public Safety	\$17,113	\$7,923	\$24,268
Public Services/Works	\$3,998	\$1,763	\$23,978
Community Services	0	\$2,739	\$3,323
Cultural, Parks and Recreation	\$8,466	\$1,403	\$7,699
Water and Sewer	0	\$5,684	\$27,157
Public Transportation	\$27,266	0	0
Sanitation/Solid Waste	0	\$1,841	\$7,089
Corrections	\$23,051	0	0
Public Assistance/Health and Welfare	\$12,978	0	0
Other	\$36,810	\$447	\$13,738
Total	\$139,477	\$25,198	\$120,691

Source: Brazoria County 2011; City of Alvin 2011; City of Pearland 2011.

3.9.1.4 Community/Public Services

Calcasieu Parish, Louisiana

Public safety and emergency services are provided to the area surrounding the LCCE Gasification plant and Lake Charles CCS Capture and Compression facilities by the City of Sulphur and Calcasieu Parish. Public safety/police protection would be provided to the project area by the Calcasieu Parish Sheriff’s Office and the City of Sulphur Police Department. The Calcasieu Parish Sheriff’s Office has 176 patrol officers and additional police and civilian personnel who staff other divisions (Calcasieu Parish Sheriff’s Office 2011). In 2010 the Sulphur Police Department had 42 police officers and 25 civilian personnel.

Fire and emergency services are provided by a combination of professional and volunteer departments spread throughout the parish. There are 16 fire departments (six volunteer fire departments, eight fire departments with both volunteer and professional firefighters, and two professional fire departments) in Calcasieu Parish. Included in this number are the Sulphur Fire Department, which is staffed by 33 professional firefighters; two volunteer fire departments in the City of Sulphur; the Carlyss Volunteer Fire Department, which has six paid firefighters and 25 volunteers; and the Houston River Volunteer Fire Department, which has 10 volunteer firefighters (Louisiana Interagency Coordination Center 2011).

The proposed CO₂ pipeline would be located within the City of Sulphur and Calcasieu Parish, Louisiana, with the same public services as described above for the LCCE Gasification plant and Lake Charles CCS Capture and Compression facilities.

Brazoria County, Texas

Public safety and emergency services are provided by Brazoria County and the cities of Alvin and Pearland. Public safety/police protection is provided by the Brazoria County Sheriff’s Department, the Alvin Police Department, and the Pearland Police Department. The Alvin Police Department has a staff of 69 personnel, including 44 sworn police officers and 25 civilian personnel (Alvin Police Department 2011). In 2010 the Pearland Police Department was staffed by 177 employees, in four divisions, including 123 sworn police officers and 54 civilian personnel (Pearland Police Department 2011).

Fire protection is currently provided to Brazoria County by 27 volunteer and professional fire departments located throughout the county (Brazoria County Fire Fighters Association 2011). The city of Alvin is served by the Alvin Volunteer Fire Department, which is staffed by five paid support staff and 70 volunteers. The department operates three fire stations located in primarily residential areas of the city (Alvin Volunteer Fire Department 2011). The City of Pearland Fire Department is a combined professional/volunteer organization, which operates six fire stations and a public safety training facility in the city of Pearland. The fire department has 65 volunteers, which are used to supplement the work of the paid firefighters (Pearland Fire Department 2011).

3.9.2 Environmental Justice

Environmental justice refers to a federal policy established by Executive Order 12898 (59 *Federal Register* [FR] 7629), under which each federal agency identifies and addresses, as appropriate, disproportionately high and adverse human health or environmental effects of its programs, policies, and activities on minority or low-income populations.

Since the states of Louisiana and Texas have not defined the criteria for an environmental justice area, this analysis will rely on the community of comparison (COC) approach that the federal government uses to define an environmental justice area. The COC approach analyzes the economic and racial factors of a potentially impacted community and compares the same factors to that of the county and/or state level. According to 15 US Code § 689 (3), the U.S. Department of Housing and Urban Development (HUD) defines a low-income community as a census tract having a poverty rate that is greater than 20%, among other indicators. Consideration of the potential consequences of a proposed project for environmental justice requires three main components:

- A demographic assessment of the affected community to identify whether minority or low-income populations that may be potentially affected are present;
- An assessment of all potential impacts identified to determine whether any would result in a significant adverse impact on the affected environment; and
- An integrated assessment to determine whether any disproportionately high and adverse impacts exist for minority and low-income groups present in the study area.

The CEQ guidance document *Environmental Justice: Guidance Under the National Environmental Policy Act* directs that a minority population should be identified where the percentage of minorities in an affected area either exceeds 50% or is meaningfully greater than in the general population of the larger surrounding area (CEQ 1997). A minority population is a group of individuals identified or recognized as African-American, Asian American/Pacific Islander, Native American, or Hispanic. Hispanic refers to ethnicity and language, not race. For the purposes of this analysis, the State (Texas or Louisiana) and the respective County/Parish will be used as the COC to determine whether a minority or low-income population could be disproportionately impacted by project activities. The analysis will compare the percentages of minority population, Hispanic population, and percentage below the poverty level for individual census tracts within the associated study area against the same indicators for the State, County/Parish, and the appropriate township/city. Census tracts that have poverty, minority, and/or Hispanic population rates that are higher than that of the COC will be identified in order to determine a potential environmental justice area.

3.9.2.1 LCCE Gasification and CO₂ Capture and Compression Facilities

The study area for this environmental justice analysis consists of the 22 census tracts within an approximately 1-mile radius of the LCCE Gasification plant and Lake Charles CCS Project CO₂ Capture and Compression facilities. The study area is located entirely within Calcasieu Parish and the City of Sulphur. Census tracts included within the study area have a combined total population of 772 persons (USCB 2010).

The 2010 U.S. Census data analysis identified whether the study area contains populations living below the poverty level, and minority and/or Hispanic populations compared to the Parish and state levels. Within the study area, 7.6% of the population lives below the poverty level, 4.8% of the population consists of minorities, and 3.2% of the population is of Hispanic origin, which indicates that the area does not represent an environmental justice concern. These percentages are significantly below the state, parish, and city levels. In the State of Louisiana, 18.7% of the population lives below the poverty level, 37.5% of the population consists of minorities, and 4.2% of the population is of Hispanic origin. In Calcasieu Parish, 16.5% of the population lives below the poverty level, 29.2% of the population consists of minorities, and 2.6% of the population is of Hispanic origin. In the city of Sulphur, 15.3% of the population lives below the poverty level, 10.2% of the population consists of minorities, and 3.4% of the population is of Hispanic origin. Therefore, the study area would not be considered an environmental justice area.

To further determine presence of individual environmental justice areas, each individual census tract and census block group within the study area was reviewed against the COC. This analysis considers the study area, Census Tract 32, and Block Group 1075, which is within both the study area and Census Tract 32. In Census Tract 32, 6.8% of the population lives below the poverty level, 7.7% of the population consists of minorities, and 2.5% of the population is of Hispanic origin. All are significantly below the city, parish, and state levels (see Table 3.9-19). The analysis uses poverty rate for the associated census tract when poverty data is not available at the census block group level. Census block groups within the study area exhibit lower percentages of population living below the poverty level, minority population, or Hispanic population. Therefore, no environmental justice areas occur within the study area.

Table 3.9-19 Percent Minority and Low-Income Characteristics Within the Study Area

Geography	Total Population (2010)	Percent of Population below the Poverty Level (2009)¹	Percent Minority (non-white) Population (2010)	Percent Hispanic (2010)
State of Louisiana	4,533,372	18.7	37.5	4.2
Calcasieu Parish	192,768	16.5	29.2	2.6
City of Sulphur	20,410	15.3	10.2	3.4
Study Area	772	7.6	4.8	3.2
Census Tract 32	2,167	6.8	7.7	2.5
Block Group 1075)	41	NA	2.4	0.0
Census Tract 18.01	10,041	5.3	11.9	2.5
Block Group 2003	715	NA	5.0	3.2

Source: USCB 2009, 2010.

¹ Population below the poverty level is not available for census block groups; therefore, the percent population below the poverty level for study area consists of data for respective census tracts.

3.9.2.2 CO₂ Pipeline Route

The study area for this environmental justice analysis consists of 211 census block groups within a 1-mile radius, or 0.5 mile on each side of the centerline of the proposed CO₂ pipeline route within Calcasieu Parish and the City of Sulphur. The study area has a total population of 7,147 persons (USCB 2010).

Table 3.9-20 identifies the census tracts within the study area with populations living below the poverty level and minority and/or Hispanic populations at higher percentages than the parish and state levels. Within the study area, 13.2% of the population lives below the poverty level, 18.6% of the population consists of minorities, and 2.3% of the population is of Hispanic origin. These rates are significantly lower than for the State of Louisiana, where 18.7% of the population lives below the poverty level, 37.5% of the population consists of minorities, and 4.2% of the population is of Hispanic origin; and lower than for Calcasieu Parish, where 16.5% of the population lives below the poverty level, 29.2% of the population consists of minorities, and 2.6% of the population is of Hispanic origin. In the city of Sulphur, 15.3% of the population lives below the poverty level, 10.2% of the population consists of minorities, and 3.4% of the population is of Hispanic origin. Therefore, the study area as a whole is not considered an environmental justice area.

Table 3.9-20 identifies the census tracts within the study area with a percentage of the population living below the poverty level and/or a percentage of minority and/or Hispanic populations greater than for the city, parish, or state. Census Tracts 23, 31.02, and 32 include percentages of the population living below the poverty rate or consisting of minorities and/or Hispanic origin less than the corresponding percentages for the city, parish, and state. However, in Census Tract 27, 21.5% of the population lives below the poverty level, which is higher than the percentages for the city, parish, and state. Also in Census Tract 27, 14.4 % of the population consists of minorities and 2.4% consists of persons of Hispanic origin, which is below the corresponding percentages for the city, parish, and state.

Table 3.9-20 Percent Minority and Low-Income Characteristics within of the Study Area of the Proposed CO₂ Pipeline

Geography	Total Population (2010)	Percent of Population below the Poverty Level (2009) ¹	Percent Minority (non-white) Population (2010)	Percent Hispanic (2010)
State of Louisiana	4,533,372	18.7	37.5	4.2
Calcasieu Parish	192,768	16.5	29.2	2.6
City of Sulphur	20,410	15.3	10.2	3.4
Study Area	7,147	13.2	18.6	2.3
Census Tract 23	2,835	11.5	5.5	1.8
Block Group 1027	136	NA	30.9	2.2
Block Group 1034	27	NA	44.4	0
Block Group 1110	49	NA	44.8	0
Census Tract 27	8,352	21.5	14.4	2.4
Block Group 1016	99	NA	70.7	0
Block Group 1017	36	NA	75	0
Block Group 1020	538	NA	26.8	4.3
Block Group 1035	55	NA	89	1.8

Table 3.9-20 Percent Minority and Low-Income Characteristics within of the Study Area of the Proposed CO₂ Pipeline

Geography	Total Population (2010)	Percent of Population below the Poverty Level (2009) ¹	Percent Minority (non-white) Population (2010)	Percent Hispanic (2010)
Block Group 1059	55	NA	89.1	0
Block Group 2012	44	NA	20.5	0
Block Group 2024	83	NA	19.2	0
Block Group 2034	18	NA	50	5.6
Block Group 2039	95	NA	94.7	1.1
Block Group 2040	72	NA	85	0
Block Group 2043	41	NA	87.8	0
Block Group 2044	27	NA	85.2	0
Block Group 2045	82	NA	85.4	8.5
Block Group 2047	29	NA	75	0
Census Tract 31.02	2,282	5.9	9.5	2.3
Block Group 1001	61	NA	24.6	1.6
Block Group 1020	115	NA	25.2	8.7
Block Group 1021	46	NA	32.6	8.7
Census Tract 32	2,167	6.8	7.7	2.5
Block Group 1067	24	NA	25	8.3
Block Group 1148	184	NA	19.6	4.3
Block Group 2014	214	NA	28.0	2.3

Source: USCB 2009, 2010.

¹ Population below the poverty level is not available for census block groups; therefore, the percentage of population below the poverty level for the study area consists of data for respective census tracts.

A total of 23 individual census block groups (only block groups with at least a population greater than 10 people) within the study area contain higher populations of minorities and/or Hispanic origin than corresponding percentages for the city, parish, and state. Since poverty data is not available at the census block group level, the poverty rate for the associated census tract is used for the COC analysis. Within Census Tracts 23, 31.02, and 32, there are nine census block groups within the study area with a minority and/or Hispanic population at greater than the city, parish, and/or state levels. These census block groups are in census tracts with a percent of the population below the poverty level below the levels in the COCs. Within Census Tract 27, 14 census block groups include areas with significantly higher rates of minority and/or Hispanic populations. Therefore these 14 census block groups may represent an environmental justice area in the vicinity of the proposed CO₂ pipeline route.

Alternative CO₂ Pipeline

The study area for the alternative CO₂ pipeline environmental justice analysis consists of 138 census block groups within a 1-mile radius (0.5 mile on each side of the centerline) of the route entirely within Calcasieu Parish and the City of Sulphur. The study area has a total population of 7,801 persons (US Census 2010).

The 2010 U.S. Census data analysis determined whether the study area populations living below the poverty level and minority and/or Hispanic populations occur at higher percentages than the

parish and state levels. Within the study area, 11.3% of the population lives below the poverty level, 10.9% of the population consists of minorities, and 2.6% of the population is of Hispanic origin. These rates are significantly lower than for the State of Louisiana, where 18.7% of the population lives below the poverty level, 37.5% of the population consists of minorities, and 4.2% of the population is of Hispanic origin. The rates are also lower than those for Calcasieu Parish, where 16.5% of the population lives below the poverty level, 29.2% of the population consists of minorities, and 2.6% of the population is of Hispanic origin. In the city of Sulphur, 15.3% of the population lives below the poverty level, 10.2% of the population consists of minorities, and 3.4% of the population is of Hispanic origin. Therefore, the study area as a whole is not considered an environmental justice area.

To further determine whether individual environmental justice areas are present in the vicinity of the project site, census data for individual census tracts and census block groups within the study area were reviewed against the COC. Table 3.9-21 identifies the census tracts within the study area that had a percentage of the population living below the poverty level and/or a percentage of minority and/or Hispanic populations greater than for the city, parish, or state.

The study area crosses Census Tracts 18.01, 27, 29, 32 33, and 34. In Census Tracts 18.01, 29, 32, 33 and 34, the percentages of the population living below the poverty rate or consisting of minorities and/or Hispanic origin are less than the corresponding percentages for the city, parish, and state. However, in Census Tract 27, the percentage of the population living below the poverty level is 21.5%, which is higher than the percentages for the city, parish, and state. Also in Census Tract 27, the percentages of the population consisting of minorities (14.4%) or Hispanic origin (2.4%) are below the corresponding percentages for the city, parish, and state.

There are a total of 25 individual census block groups (only block groups with at least a population greater than 10 people) within the study area that have higher populations of minorities and/or people of Hispanic origin. The analysis uses poverty rate for the associated census tract when poverty data is not available at the census block group level. Census Tracts 18.01, 29, 32, 33 and 34 contain 18 census block groups with a minority and/or Hispanic population at greater than the city, parish and/or state levels. These census block groups are in census tracts with a percent of the population below the poverty level below the levels in the COCs. Census Tract 27 contains 14 census block groups with significantly higher rates of minority and/or Hispanic populations. Therefore, these 14 census block groups may represent an environmental justice area in the vicinity of the alternative pipeline route.

Table 3.9-21 Percent Minority and Low Income Characteristics, Alternative CO₂ Pipeline

Geography	Total Population (2010)	Percent of Population below the Poverty Level (2009)¹	Percent Minority (non-white) Population (2010)	Percent Hispanic (2010)
State of Louisiana	4,533,372	18.7	37.5	4.2
Calcasieu Parish	192,768	16.5	29.2	2.6
City of Sulphur	20,410	15.3	10.2	3.4
Study Area	7,801	11.3	10.9	2.6
Census Tract 18.01	10,014	7.8	12.8	2.5
Block Group 2003	726	NA	8.1	3.2
Census Tract 27	8,352	21.5	14.4	2.4
Block Group 3012	30	NA	13.3	13.3

Table 3.9-21 Percent Minority and Low Income Characteristics, Alternative CO₂ Pipeline

Geography	Total Population (2010)	Percent of Population below the Poverty Level (2009) ¹	Percent Minority (non-white) Population (2010)	Percent Hispanic (2010)
Block Group 3018	15	NA	13.3	13.3
Block Group 4023	29	NA	17.2	0.0
Block Group 4027	110	NA	11.8	0.0
Block Group 4030	42	NA	14.3	0.0
Block Group 4031	33	NA	18.1	0.0
Block Group 4033	27	NA	14.8	0.0
Census Tract 29	2,086	3.9	6.0	3.2
Block Group 2022	103	NA	10.7	2.9
Census Tract 32	2,167	6.8	7.7	2.5
Block Group 1108	162	NA	27.8	16.7
Census Tract 33	4,800	12.1	10.9	1.7
Block Group 1012	14	NA	35.7	28.7
Block Group 1017	56	NA	12.5	0.0
Block Group 1018	51	NA	11.8	9.8
Block Group 1019	36	NA	30.6	0.0
Block Group 1030	26	NA	11.5	11.5
Block Group 1033	147	NA	19.7	11.5
Block Group 2000	511	NA	65.9	1.2
Block Group 2002	42	NA	28.6	0.0
Block Group 2011	14	NA	35.7	0.0
Block Group 2021	59	NA	13.6	5.1
Block Group 2026	159	NA	7.5	6.9
Block Group 3031	18	NA	16.7	5.6
Block Group 3035	133	NA	5.3	5.3
Census Tract 34	4,619	5.1	3.7	1.8
Block Group 2003	28	NA	3.6	3.6
Block Group 2016	560	NA	7.5	3.6

Source: USCB 2009, 2010.

¹ Population below the poverty level is not available for census block groups; therefore, the percentage of population below the poverty level for the study area consists of data for respective census tracts.

3.9.2.3 West Hastings Research MVA

The study area for this environmental justice analysis consists of 259 census tracts within an approximately one-mile radius of the proposed West Hastings research MVA site. The study area has a total population of 8,016 persons (USCB 2010).

The 2010 U.S. Census data analysis identified census tracts within the study area with populations living below the poverty level and minority and/or Hispanic populations present at percentages higher than the county and state levels. Within the study area, 13.7% of persons live below the poverty level, 47.3% of persons are minorities, and 51.4% are persons of Hispanic origin. In Texas, 16% of the population lives below the poverty level. However, the study area reflects significantly greater percentages of minority and Hispanic populations than Texas, where 29% of the population consists of minorities and 32% consists of persons of Hispanic origin.

The percentages for the study area are also greater than for Brazoria County, where 5% live below the poverty level, 30% of the population consists of minorities, and 28% are persons of Hispanic origin. Therefore, the West Hastings research MVA study area is considered an environmental justice area.

Table 3.9-22 identifies the census tracts and census block groups within the study area with either percentages of population living below the poverty level and/or had percentages of minority and/or Hispanic populations greater than the city, county, or state levels. The study area crosses five census tracts (Census Tracts 6602, Census Tract 6603, Census Tract 6609, Census Tract 6610 and Census Tract 6611). All census tracts live below the poverty rate or contain percentages of minorities and/or Hispanic populations higher than the city, county, and/or state levels. However, Census Tracts 6609, 6610, and 6611 all have percentages of population living below the poverty level and percentages of minority and Hispanic populations that are above the city, county, and state levels.

A total of 68 individual census block groups (i.e., block groups with a population greater than 10 people) within the study area contain higher rates of minority and/or Hispanic populations than the city, parish, and/or state levels or rates of minority population above 50%. The analysis uses poverty rate for the associated census tract when poverty data is not available at the census block group level. Within Census Tracts 6602 and 6603, 20 census block groups exceed the city, parish, and/or state levels for percentages of minority and/or Hispanic population and fall below the poverty level. Within Census Tracts 6609, 6610, and 6611, 48 census block groups exceed the rates of minority and/or Hispanic populations. Therefore, these 68 census block groups may represent an environmental justice area in the vicinity of the West Hastings research MVA site.

Table 3.9-22 Percent Minority and Low-Income Characteristics: West Hastings Research MVA Site

Geography	Total Population (2010)	Percent of Population below the Poverty Level (1999)¹	Percent Minority (non-white) Population (2010)	Percent Hispanic (2010)
State of Texas	25,373,947	16	29	32
Brazoria County	313,166	12.5	30	28
City of Alvin	24,236	13.8	21	1.0
City of Pearland	86,706	4.0	38	21
Study Area	8,022	13.7	47.3	51.4
Census Tract 6602	5,638	7.2	19.4	20.5
Block Group 1010	27	NA	37.0	37.0
Block Group 1012	73	NA	52.1	52.1
Block Group 1014	33	NA	45.5	45.5
Block Group 1027	10	NA	20.0	20.0
Block Group 1065	52	NA	59.6	59.6
Block Group 1077	127	NA	49.6	46.5
Block Group 1092	16	NA	25	6.3
Block Group 1094	42	NA	57.1	54.7
Block Group 1095	15	NA	53.3	26.7
Block Group 1099	21	NA	47.6	47.6
Block Group 2024	64	NA	35.9	35.9
Block Group 2035	39	NA	41.0	41.0
Block Group 2053	47	NA	19.1	14.9

Table 3.9-22 Percent Minority and Low-Income Characteristics: West Hastings Research MVA Site

Geography	Total Population (2010)	Percent of Population below the Poverty Level (1999)¹	Percent Minority (non-white) Population (2010)	Percent Hispanic (2010)
Census Tract 6603	9,536	7.1	21.2	19.7
Block Group 2001	22	NA	27.2	4.5
Block Group 2002	601	NA	25.6	17.9
Block Group 2004	39	NA	35.8	25.6
Block Group 2008	86	NA	18.6	18.6
Block Group 2009	35	NA	17.1	14.2
Block Group 2010	24	NA	20.8	20.8
Block Group 2011	91	NA	20.9	7.7
Census Tract 6609	6,806	21.2	34.0	53.0
Block Group 3011	11	NA	36.4	27.7
Block Group 3016	30	NA	56.7	56.7
Block Group 3017	957	NA	73.5	71.5
Block Group 3018	36	NA	69.4	61.1
Block Group 3020	36	NA	86.1	86.1
Block Group 3021	14	NA	85.7	78.5
Block Group 3022	42	NA	76.2	76.2
Block Group 3023	81	NA	86.4	86.4
Block Group 3024	61	NA	80.3	80.3
Block Group 3025	115	NA	74.8	74.8
Block Group 3027	10	NA	100	100
Block Group 3028	31	NA	100	100
Block Group 3029	30	NA	93.3	93.3
Block Group 3082	21	NA	23.8	23.8
Block Group 3091	10	NA	60.0	40.0
Block Group 3094	53	NA	54.7	54.7
Block Group 3098	23	NA	82.6	82.6
Block Group 3101	84	NA	88.1	82.1
Block Group 3027	26	NA	61.5	53.8
Block Group 4014	790	NA	68.2	62.9
Block Group 4016	46	NA	32.6	17.4
Block Group 4017	66	NA	72.7	71.2
Block Group 4018	60	NA	66.7	48.3
Block Group 4025	40	NA	95.0	95.0
Block Group 4031	77	NA	92.2	92.2
Block Group 4034	20	NA	80.0	35.0
Block Group 4035	21	NA	57.1	57.1
Block Group 4045	243	NA	73.3	71.6
Block Group 4048	34	NA	94.1	94.1
Block Group 4049	27	NA	81.4	81.4
Census Tract 6610	6,432	17.6	30.4	38.1
Block Group 2000	457	NA	22.5	20.8
Block Group 3000	21	NA	47.6	47.6
Block Group 3001	134	NA	58.2	54.5
Block Group 3003	23	NA	73.9	73.9
Block Group 3004	120	NA	61.7	60.8

Table 3.9-22 Percent Minority and Low-Income Characteristics: West Hastings Research MVA Site

Geography	Total Population (2010)	Percent of Population below the Poverty Level (1999)¹	Percent Minority (non-white) Population (2010)	Percent Hispanic (2010)
Block Group 3005	151	NA	57.6	52.9
Block Group 3007	47	NA	31.9	27.7
Block Group 3008	56	NA	67.9	67.9
Block Group 3010	43	NA	79.1	79.1
Block Group 3012	742	NA	53.8	48.5
Block Group 3015	84	NA	86.9	86.9
Block Group 3019	94	NA	95.7	95.7
Block Group 3020	45	NA	51.1	45.0
Block Group 3021	72	NA	41.7	38.9
Block Group 3022	88	NA	31.8	26.1
Block Group 3040	12	NA	75.0	75.0
Block Group 3072	46	NA	41.3	41.3
Census Tract 6611	3,175	21.3	24.6	41.4
Block Group 2004	49	NA	34.7	26.5

Source: USCB 2009, USCB 2010.

¹ Population below the poverty level is not available for census block groups; therefore, the percentage of population living below the poverty level for study area consists of data for respective census tracts.

3.10 Traffic and Transportation

3.10.1 Regional and Local Roadway System

Lake Charles, Louisiana

DOE identified and reviewed national, statewide, and regional transportation plans to determine the existing conditions of transportation systems within the project area. Transportation plans reviewed include:

- National Interstate 10 Freight Corridor Study (Wilbur Smith Associates 2002)
- Louisiana Statewide Transportation and Infrastructure Plan 2003 (LDOTD 2003)
- Vision Calcasieu 2009 (ICPJ 2009)
- Lake Charles Urbanized Area Metropolitan Transportation Plan 2009-2034 (IMCAL 2009)

In 2009, the Imperial Calcasieu Regional Planning and Development Commission (IMCAL) produced the Metropolitan Transportation Plan 2034 (MTP 2034) to provide a baseline picture of all infrastructure facilities for the various modes of transportation in the Lake Charles Urbanized Area. DOE used data from the MTP 2034 to describe the existing transportation infrastructure in the Lake Charles Urbanized Area.

The proposed project would utilize the Lake Charles Urbanized Area transportation system, which includes federal and state highways, local roads, rail lines, and port facilities in the cities of Lake Charles, Westlake, Sulphur, and Carlyss, Louisiana. This transportation system would

potentially be used for worker commutes and delivery of materials during fabrication, construction, and operation. DOE used the Louisiana Department of Transportation and Development (LDOTD) Statewide Transportation plan (2003), the official LDOTD District 7 Control Section map (LDOTD 2012a) and the LDOTD District 7 Functional Classification Map (LDOTD 2012b) to assess the structure, functional classification, and operating conditions of the regional and local roadway system. The LDOTD assigns functional classifications to roadways in Louisiana to describe the hierarchical arrangement and interaction between various roadways. Classification is based on each roadway's functional role in the overall network, including traffic movement and access (LDOTD 2003, 2012b). Principal arterial systems are major roadways that carry the majority of trips entering and leaving an urban or rural area as well as a majority of through movements desiring to bypass central metropolitan areas (IMCAL 2009). Principal arterials provide high levels of travel mobility to a large geographic area. Minor arterial street systems interconnect with and augment principal arterial systems and provide service to trips of moderate length at a lower level of travel mobility than principal arterials. Minor arterials also serve a smaller geographic area than principal arterials. DOE used LDOTD functional classification data to assess the functional classification and characteristics of roadways near the project area that would be used for the transport of personnel, materials, and equipment. These roadways include Interstate 10 (I-10), State Highway 27, State Highway 1256/Ruth Street, State Highway 108, and Bayou D'Inde Road (LDOTD 2012a; IMCAL 2009).

Figure 3.10-1 shows the functional classification of transportation infrastructure in Lake Charles Urbanized area in the vicinity of the Lake Charles CCS project and the LCCE Gasification project. The Interstate 10 (I-10) corridor, which runs east-west from Florida to California, passes through the city of Lake Charles, connecting the city with Sulphur and Vinton, Louisiana, and eventually crosses the Louisiana-Texas state border to the west (LDOTD 2003). To the east lie the towns of Iowa and Jennings. Interstate 10, a principal arterial highway located approximately 3 miles north of the LCCE Gasification plant site, would provide primary regional access to the site. Near the project area, I-10 has six travel lanes, three in each direction, and a posted speed limit of 60 mph. State Highway 108, a four-lane minor arterial highway, would be the primary arterial highway linking the gasification plant site to the I-10 corridor. Highway 108 travels east-west and is the primary east-west roadway south of I-10, providing access from Vinton to Sulphur, Louisiana. State Highway 27, a two-lane rural major collector, runs north-south through Calcasieu Parish. State Highway 27 provides direct access from Beauregard Parish (to the north) and Cameron Parish (to the south) to I-10 and State Highway 108. Ruth Street, also a two-lane rural major collector, provides a north-south connection from Sulphur and communities to the north to I-10 and Highway 108. The LCCE Gasification plant is located on Bayou D'Inde Road, a two-lane local street that connects directly to Highway 108, which connects to I-10. Bayou D'Inde Road provides access to the LCCE Gasification plant and Lake Charles CCS CO₂ Capture and Compression facilities, construction equipment laydown area, methanol and sulfuric acid pipelines storage areas, and utilities. Interstate 10, Highway 90, State Highway 27, and State Highway 108 would provide access to the water supply and hydrogen pipelines, and existing local roadways and ROWs would provide access along the length of the routes during construction and operation. Temporary access roads would be constructed along the proposed ROW as necessary, although the existing road network would be used for access as available.

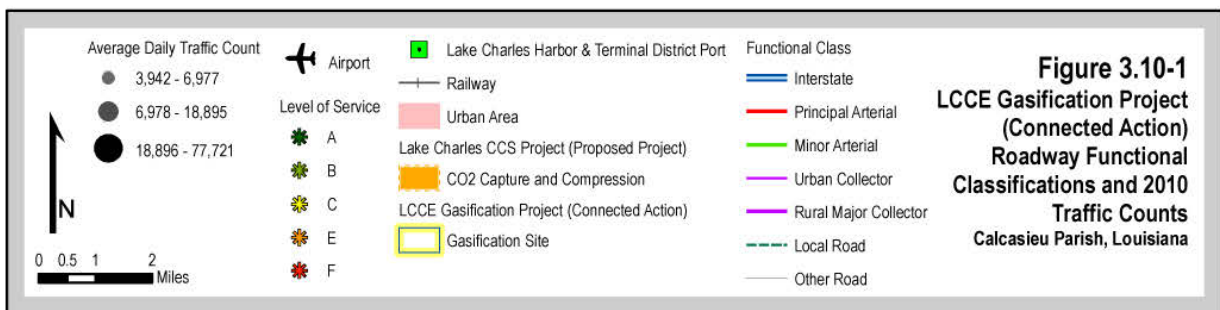
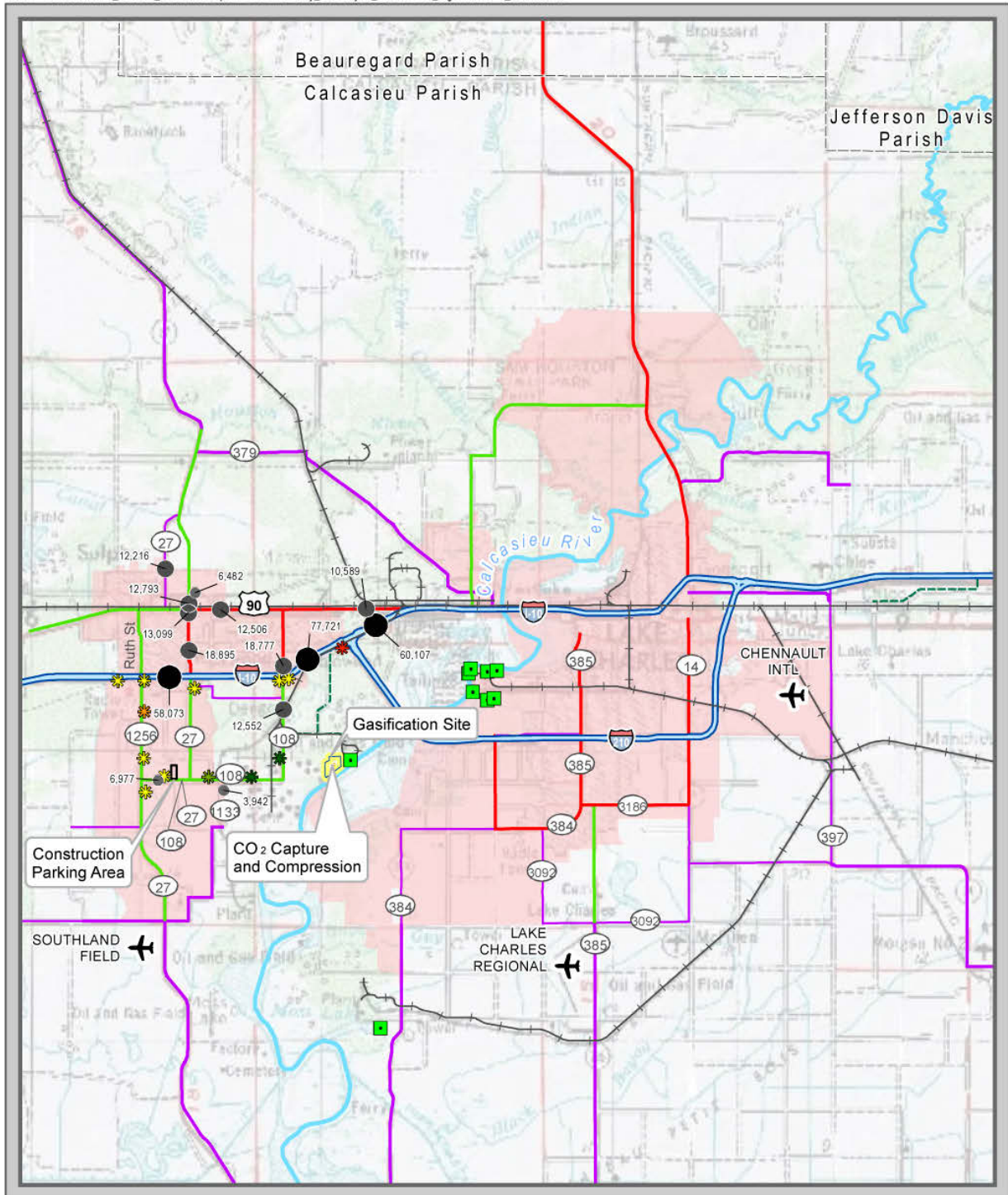

This page left blank intentionally.

Annual Average Daily Traffic (AADT) is the total volume of traffic passing a point or segment of a highway facility in both directions for 1 year divided by the number of days in the year.

To assess existing traffic volumes, DOE obtained the 2010 Average Annual Daily Traffic (AADT) volumes for roadways in the vicinity of the proposed project from the LDOTD AADT Database (LDOTD 2010) AADT volumes are listed in Table 3.10-1 and also shown in Figure 3.10-1.

Table 3.10-1 2010 Average Annual Daily Traffic (AADT) Counts

Roadway Name	Milepost	2010 AADT
Interstate 10	20.7	37,434
Interstate 10	21.68	58,073
Interstate 10	24.78	77,221
Interstate 10	26.41	60,107
State Highway 108	85.82	18,777
State Highway 108	84.86	12,552
State Highway 27/108	80.68	6,977
State Highway 1256 – Ruth Street	80.76	16,256
State Highway 1256 – Ruth Street	80.53	12,191
State Highway 27 south	79.46	12,204
Bayou D’Inde Road	not available	not available

Source: LDOTD Estimated Annual Average Daily Traffic Counts Website. LDOTD 2010.

Interstate 10 is the major principal arterial in the region and experiences heavy automobile and truck volumes between the Texas State line and the City of Lake Charles (Wilbur Smith Associates 2002; IMCAL 2009). The high volume of traffic utilizing the I-10 corridor reflects the presence of numerous multi-modal ports, refineries, and chemical plants located in southeastern Texas and southwestern Louisiana (Wilbur Smith 2002; LDOTD 2003). Traffic volumes on Highway 108 and Bayou D’Inde Road are typical of industrial areas. Bayou D’Inde Road generally experiences relatively low traffic volumes and minor roadway congestion. Higher traffic volumes occur during the peak commuting hours.

Quality of service describes how well a transportation facility or service operates from a traveler’s perspective. Quality of service can be assessed in a number of ways, including directly observing factors perceivable by and important to travelers, surveying travelers, tracking complaints and compliments about roadway conditions, forecasting traveler satisfaction by using models derived from past traveler surveys, and observing services not directly perceived by travelers that effect measures they can perceive (TRB 2010). Level of Service (LOS) is a scale that measures the quality of service of a roadway. Six levels of service are assigned letter designations ranging from A to F, with LOS A (free flow, little delay) representing the best operating conditions from the travelers perspective and LOS F (congestion, long delays) representing the worst conditions (TRB 2010). For signalized intersections, LOS is calculated based on the ratio of the measured demand volume of a roadway to its given design capacity. For controlled intersections, LOS is based on average vehicular delay. For freeways, LOS is based on the ratio of demand on a roadway capacity of that roadway. The six LOS designations are summarized in Table 3.10-2.

No LOS standards currently exist in Calcasieu Parish; however, LOS designations of A, B, or C, are typical of “good” operating conditions. DOE contacted the LDOTD to obtain estimates of the 2012 LOS for roadways within the project area. These estimates were developed for planning purposes only and should not be used as a reference for the design or construction of transportation infrastructure. Table 3.10-3 shows the estimated 2012 baseline LOS for selected roadways within the project and the IMCAL transportation model projected future LOS conditions for the year 2014. Figure 3.10-1 shows the 2012 baseline LOS for roadways within the project area in Calcasieu Parish (LDOTD 2012c; IMCAL 2009).

Table 3.10-2 Level of Service Designations

Level of Service	Traffic Conditions
A	Little or no congestion or delay
B	Slight congestion or delay
C	Moderate congestion or delay
D	Substantial congestion or delay
E	Extreme congestion or delay
F	Roadway failure and gridlock

Source: TRB 2010.

Table 3.10-3 2012 Estimated Level of Service on Roadways During Construction

Roadway	2012 Estimated LOS ¹	Project 2014 LOS ²
Interstate 10: Highway 1256 to the I-210 Interchange	C	C/D
Interstate 10: I-210 Interchange East to Lake Charles	F	F
State Highway 108 at I-10	C	C
State Highway 108 west to State Highway 1133	A	B
State Highway 108 west to State Highway 27	B	B
State Highway 27 at I-10	C	C
State Highway 27/ State Highway 108 west	C	C
State Highway 27 south	C	C
State Highway 1256/Ruth Street at I-10	C	E
State Highway 1256/Ruth Street south at Patch Street	E	E
State Highway 1256 south at State Highway 27/108	C	C
Bayou D’Inde Road	not available	C

¹ Source: LDOTD 2012c. LOS estimates in this table were developed for planning purposes only and should not be used for the design or construction of roads or any other transportation infrastructure.

² Source: IMCAL 2009. LOS forecasts were based on transportation demand model volume to capacity (v/c) ratios and are for informational and planning purposes only.

In Southwest Louisiana, I-10 generally exhibits an acceptable LOS of C from the Texas state line to Westlake, Louisiana, just before the I-210 interchange (Wilbur Smith 2002; LDOTD 2003). The Calcasieu River divides the city of Lake Charles from the cities of Westlake and Sulphur. The I-10 and I-210 bridges are the only two bridges in the region that provide east-west access across the Calcasieu River between Lake Charles and Sulphur (IMCAL 2009). Between the cities of Westlake and Lake Charles, I-10 exhibits a LOS of F from the I-210 through the I-10 interchange, and west along I-10 across the I-10 Calcasieu River Bridge to Lake Charles. This poor level of service is caused by several factors, including (Wilbur Smith 2002; LDOTD 2003; IMCAL 2009):

- The design of the I-10 Calcasieu River Bridge (lack of adequate shoulders);
- The limited east-west connectivity caused by the lack of Calcasieu River crossings;
- The high volume of passenger car and freight truck traffic traveling between Lake Charles and the Texas state line; and
- Merging of vehicles at the I-10 and I-210 interchange.

These factors lead to substantial congestion along the I-10 corridor between Lake Charles and Sulphur. State Highway 108 operates at an LOS of A south of I-10 and at an LOS of B between State Highway 108 south and Areno Road. This high LOS is attributable to the fact that these segments of State Highway 108 have four lanes, are divided, and have minimal interruption from traffic lights, stop signs, and driveways.

State Highway 1256/Ruth Street exhibits an LOS of E near Patch Street because at this point Ruth Street transitions from a four-lane to a two-lane roadway. At LOS E, Ruth Street is operating at capacity; there is no room for traffic to maneuver, causing drivers to experience a poor quality of service during morning and afternoon hours when traffic volume is at its peak. The other roadways in the project area exhibit an LOS of C or better, indicating acceptable traffic conditions. Based on historical LOS data for the state and the projected LOS for roadways in the Lake Charles Urbanized Area, the LOS for the majority of the roadways within the project area currently operate at LOS C and are projected to continue to operate at these levels or degrade due to urban development.

CO₂ Pipeline Route

Interstate 10, Highway 90, State Highway 27, and State Highway 108 will provide access to the CO₂ pipeline, and existing local roadways and ROWs will provide access along the length of the pipeline corridor during construction and operation. Table 3.10-1 summarizes average daily traffic counts for these roads. Temporary access roads will be constructed along the proposed pipeline ROW as necessary, although the existing road network would be used for access as available.

Hastings Oil Field, Texas

Major roadways include State Highway 35, County Road 128, and State Highway 6. State Highway 35 runs north-south to the east of the West Hastings research MVA site; County Road 128 runs east-west to the north, and State Highway 6 runs east-west to the south. State Highway 35 and County Road 128 provide direct access to the West Hastings research MVA site. State Highway 35 is a paved, four-lane highway. County Road 128 is a paved, two-lane road. Traffic volumes are typical of rural areas. These roadways generally experience relatively low traffic volumes and minor roadway congestion.

3.10.2 Waterway and Rail Transportation

Lake Charles, Louisiana

The Lake Charles Harbor and Terminal District (Port of Lake Charles) in southwestern Louisiana encompasses 203 square miles and extends from the Ship Channel through Calcasieu

Parish (Port of Lake Charles 2011). The Port of Lake Charles includes two marine terminals (City Docks and Bulk Terminal No. 1) and two industrial parks (Industrial Canal and Industrial Park East). The Port of Lake Charles is the 11th largest seaport in the U.S. and accommodates 5 million tons of cargo annually at its public facilities (Port of Lake Charles 2011). Port of Lake Charles facilities, shown in Figure 3.10-1, are adjacent to the LCCE Gasification plant site and would provide barge and ship access for delivery of major equipment and export of methanol and sulfuric acid. Cargo rail service is provided by the Union Pacific Railroad. According to the Federal Railroad Administration, rail spurs also are located adjacent to the LCCE Gasification plant site.

3.10.3 Airports

Lake Charles, Louisiana

The major service airports in the area include Lake Charles Regional Airport, Lake Charles Chennault International Airport, Southland Field-West Calcasieu Airport, and Reynolds Airport (general aviation airport). The airport nearest to the project is the Southland Field-West Calcasieu Regional Airport, which is located 5 miles south of Sulphur, Louisiana. On average, the airport supports 54 aircraft operations per day (AIRNAV 2011a). The Lake Charles Regional Airport provides air travel for southwestern Louisiana and is located approximately 17 miles southeast of the LCCE Gasification plant site. The airport averages 153 operations per day. Lake Charles' Chennault International Airport is a fully operational airport located approximately 16 miles east of the gasification plant. Chennault averages 55 aircraft operations per day. Airports in the project area are shown on Figure 3.10-1.

Hastings Oil Field, Texas

Commercial service airports in the vicinity include Pearland Regional Airport and Houston Hobby Airport. Pearland Regional Airport is located approximately 1.3 miles north of the Hastings oil field and supports an average of 239 aircraft operations per day (AIRNAV 2011b). Houston Hobby Airport, a commercial aviation facility in Houston, is located approximately 18 miles north of the Hastings oil field and supports an average of 550 aircraft operations per day (AIRNAV 2011c).

3.11 Noise

Noise is defined as any unwanted sound. Sound is defined as any pressure variation that the human ear can detect. Humans can detect a wide range of sound pressures, but experience only the pressure variations occurring within a particular set of frequencies as sound. However, the acuity of human hearing is not the same at all frequencies. Humans are less sensitive to low frequencies than to mid-frequencies, and so noise measurements are often adjusted (or weighted) to account for human perception and sensitivities.

The unit of noise measurement is a decibel (dB). The most common weighting scale used is the A-weighted scale, developed to allow sound-level meters to simulate the frequency sensitivity of human hearing. Sound levels measured using this weighting are noted as dBA (A-weighted decibels; "A" indicates that the sound has been filtered to reduce the strength of very low and very high frequency sounds, much as the human ear does). The A-weighted scale is logarithmic, so an increase of 10 dB actually represents a sound 10 times louder. However, humans perceive the 10 dBA increase as twice as loud, not 10 times louder.

Various descriptors commonly used to evaluate sound pressure levels over time include:

- Equivalent Sound Level, or L_{eq} , is the average of the sound energy over time. The L_{eq} integrates fluctuating sound levels over a period of time to express them as a steady-state sound level.
- Day-Night Average Sound Level, or L_{dn} , is equivalent to a 24-hour L_{eq} , but with a 10-dBA penalty added to nighttime noise levels (10:00 p.m. and 7:00 a.m.) to reflect the greater intrusiveness of noise experienced during this time.
- L_{90} indicates the sound level that is exceeded 90% of the time during a sound measurement period. This is a commonly used metric for evaluating community noise in residential environments.
- L_{max} is the maximum instantaneous noise level during a specific period of time.

Figure 3.11-1 shows some typical sources and weighted sound levels. Table 3.11-1 presents sound pressure levels (SPLs) that are characteristic for the land use described.

Table 3.11-1 Common Noise Levels

Description	Sound Pressure Level (dBA)
Rural area at night	30
Quiet Suburban area at night	40
Typical suburban area	50
Typical urban area	60

Source: Cowan 1994.

The decrease in sound level caused by the distance from any single noise source normally follows the inverse square law, i.e., the SPL changes in inverse proportion to the square of the distance from the sound source. In a large, open area with no obstructive or reflective surfaces, the SPL from a point source of noise drops off at a rate of 6 dB with each doubling of distance away from the source at distances greater than 50 feet. Temperature, humidity, and the frequency of the sound affect the sound energy absorbed in the air. This attenuation can be up to 2 dB over 1,000 feet. The drop-off rate varies with both terrain conditions and the presence of obstructions in the sound propagation path.

Noise sources that affect the environment include mobile sources such as automobiles, buses, trucks, aircraft, and trains, or stationary sources such as machinery or mechanical equipment associated with industrial and manufacturing operations or building heating, ventilating, and air-conditioning systems. Sources of construction noise include both mobile sources (e.g., trucks, bulldozers, etc.) and stationary sources (e.g., compressors, pile drivers, power tools, etc.).

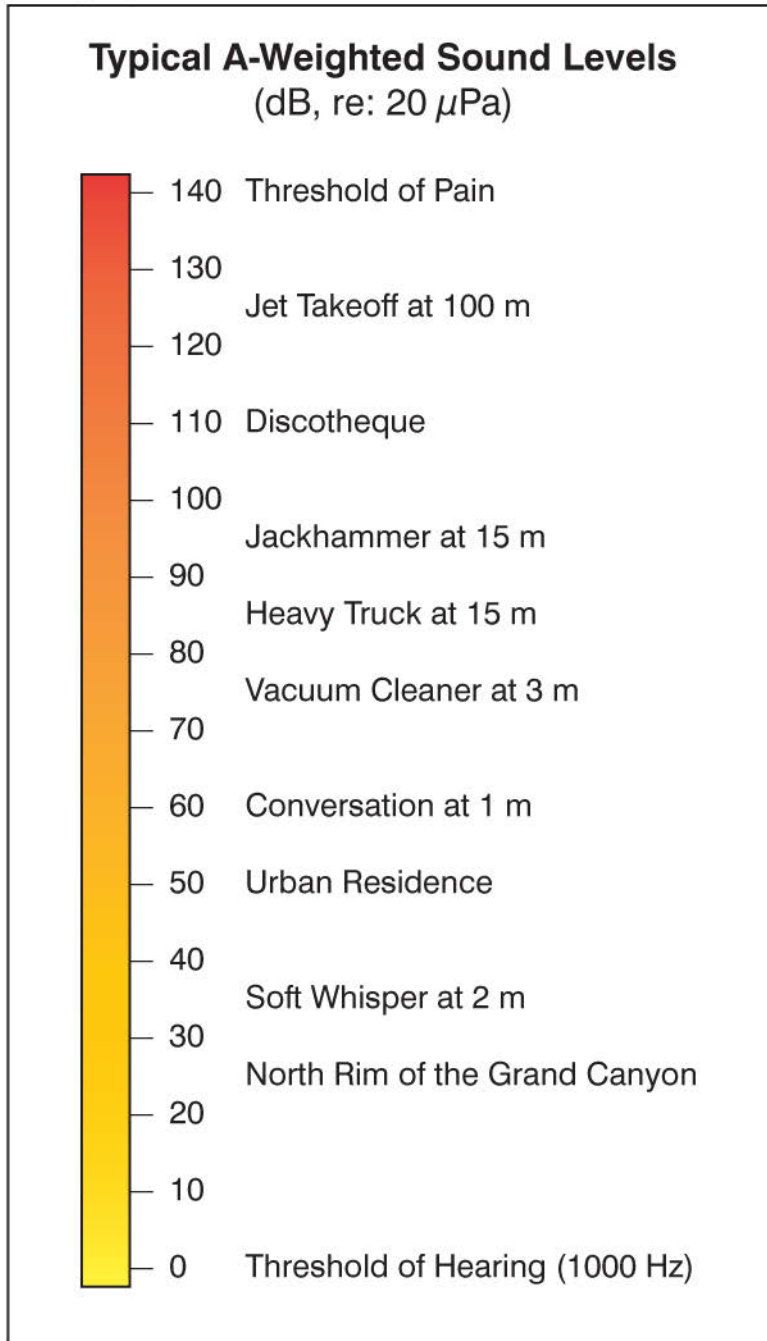

United States Department of Labor Occupational Safety and Health Administration. 2011. Occupational Noise Exposure. Available online at: <http://www.osha.gov/SLTC/noisehearingconservation/>. Accessed on November 22, 2011.

Figure 3.11-1 Sound Levels

Lake Charles, Louisiana

Existing dominant noise sources in the vicinity of the proposed site mainly consist of material delivery traffic on Bayou D'Inde Road, industrial operations along Bayou D'Inde Road and Cities Service Highway, rail traffic on the delivery rail line along Bayou D'Inde Road, and material-handling equipment associated with barge deliveries on the Calcasieu River. ATCO performed an environmental noise study to establish the baseline noise conditions at residential areas in the vicinity of the LCCE Gasification plant. Sound level measurements indicated that L_{eq} of 60 dBA and L_{90} of 53 dBA were mostly dominated by the traffic noise (industrial/commercial trucks) on Bayou D'Inde Rd and noise from the industrial facilities around the area (ATCO 2012).

Off-site activities associated with the LCCE Gasification plant addressed in the noise evaluation include portions of the methanol and sulfuric acid pipeline linears, and site utilities. The proposed water supply and hydrogen pipeline routes parallel existing ROWs (transmission lines, roads, pipelines, railroads, and other linear features) to the extent practicable. Surrounding land uses consist primarily of developed industrial and residential, forested upland and wetland areas, and pasture/agriculture areas. Existing noise levels along the proposed routes would be expected to range from approximately 45 dBA in the undeveloped and agricultural portions of the route to approximately 75 dBA when passing through industrialized areas. At potential residential noise receptors, noise levels of approximately 60 dBA would be expected due to the receptors' proximity to the industrial areas (ATCO 2012).

CO₂ Pipeline Route

Hoover & Keith, Inc., performed an environmental noise study to establish the baseline noise conditions at noise sensitive areas within 0.5 miles of either the planned HDD entry or HDD exit site along the CO₂ pipeline route. At each sound measurement location, the L_{eq} SPLs were measured and L_{dn} levels were calculated based on these levels. The calculated L_{dn} ranged from 41.9 to 61.7 dBA (Hoover & Keith 2012).

Hastings Oil Field, Texas

Background noise in the vicinity of the Hastings oil field reflects rural farmlands, suburban areas, and residential neighborhoods, as well as historical oil operations. A large portion of the West Hastings research MVA area is dedicated to pasture hay and cultivated crops. The majority of the remaining area is in open space and low-intensity development. There are approximately 61 residences located in the West Hastings research MVA program area within the Hastings oil field. As an active commercial EOR site, existing noise levels would be expected to range from 45 dBA to 65 dBA, depending on proximity to highways, agricultural activities, well reworking/reconditioning/conversion, and pumping activities.

3.12 Wastes and Materials

This section presents information on contaminated sites, existing waste and waste disposal facilities, and materials as they relate to construction and operation of the LCCE Gasification plant in Calcasieu Parish, Louisiana, and the portion of the Lake Charles CCS project in Calcasieu Parish, Louisiana, and Brazoria County, Texas.

Lake Charles, Louisiana

Historical sampling at the LCCE Gasification plant and Lake Charles CCS CO₂ Capture and Compression facilities site indicated the presence of elevated levels of constituents considered

not naturally occurring (URS 2008). LDEQ records indicate that releases from the Sulphur wastewater treatment plant (WWTP) may have migrated along the northern boundary ditch between the property and the Sulphur WWTP property, as well as in the ditch that flows into the Calcasieu Ship Channel on the eastern boundary of the property. In addition, the Himont Ditch, a large channel constructed in the late 1950s, discharged wastewater from the Basell facility to the west of the property, along with possible discharges from the LA Pigment facility on the northern side of the property.

On behalf of Leucadia, URS conducted a further investigation and evaluation of the previously reported sediment impacts in accordance with the Louisiana Risk Evaluation/Corrective Action Program (RECAP) regulations. On April 14 to 16, 2008, URS collected 18 sediment samples from the drainage ditches adjacent to the LCCE Gasification plant and Lake Charles CCS CO₂ Capture and Compression facilities. In two samples, naphthalene and beryllium were detected at concentrations exceeding the LDEQ RECAP soil screening levels protective for groundwater. The LDEQ issued a summary justification stating that no further response was required to address the exceedance, since the levels of beryllium and naphthalene were below the RECAP Management Option-1 standards (LDEQ n.d.).

The Toxic Release Inventory Program (TRIP), administered by the EPA under Section 313 of the Emergency Planning and Community Right-to-Know Act (EPCRA), requires the EPA and individual states to annually collect data on releases and transfers of certain toxic chemicals from industrial facilities and make these data available to the public via the TRI Program. A review of the TRIP database identified two separate sites providing TRI data within the Millennium Power property, located near the project site.

Table 3.12-1 describes the existing solid waste disposal facilities within the regional vicinity of the site and their capacities. There are currently no permitted Type I Non-Hazardous Industrial Solid Waste or Type II Non-Hazardous Municipal Solid Waste landfills in Calcasieu Parish. Waste Management, Inc. operates a waste management transfer station in Sulphur, Louisiana, where collected wastes are staged prior to being transported to permitted landfills in other parishes. There are two non-hazardous waste facilities in the vicinity of the proposed project and one permitted hazardous waste facility. Waste Management's permitted Lake Charles Hazardous Waste Treatment and Disposal facility, described in Table 3.12-1, is located in the vicinity of the site and is permitted to treat and dispose of hazardous waste.

No hazardous or nonhazardous solid wastes are currently stored, treated, or disposed of at the site, and no existing or past hazardous or nonhazardous waste treatment, storage, or disposal facilities were identified at the LCCE Gasification plant site or the CO₂ Capture and Compression facilities site. Leucadia would assess the presence of past or current hazardous materials, non-hazardous waste, or hazardous waste treatment generation, storage, or disposal facilities at the equipment laydown and methanol and sulfuric acid storage area when the location is selected. Prior to construction, Leucadia would assess the water and hydrogen pipeline routes to determine the presence and location of known or suspected environmental conditions and regulated sites within or along the route.

Table 3.12-1 Industrial, Municipal, and Hazardous Waste Facilities Available for Use by the LCCE Gasification Plant

LDEQ A.I. Number	Name	Parish	Permit Number	Type	Remaining Capacity (cubic yards)	Remaining Time (Years)	Ownership
12389	Jefferson Davis Parish Sanitary Landfill	Jefferson Davis Parish	P-0100-R1	I, II	7,400,000	27	Public
52277	Timberlane Landfill	Allen Parish	P-0039	I, II	8,158,970	32.42	Private
12233	Waste Management Transfer Station	Calcasieu Parish	TPU-019-1708	I, II	N/A	N/A	Private
40072	Chaney Trucking C&D Landfill	Calcasieu Parish	P-0394	III	212,427	12	Private
67860	Krause & Managan	Calcasieu Parish	P-0336	III	1,600,000*	N/A	Private
134011	McManus C&D Landfill	Calcasieu Parish	P-0421	III	2,100,000*	15	Private
742	Waste Management Lake Charles Public Waste Facility	Calcasieu Parish	LAD000777201 PER20110025	CHWL	N/A	N/A	Private

Source: LDEQ 2010.

Notes:

Type I Landfill – Non-Hazardous Industrial Solid Waste.

Type II Landfill – Non-Hazardous Municipal Solid Waste.

Type III Landfill – Construction and Demolition Debris, including exempt wood waste.

CHWL – Commercial Hazardous Waste Landfill.

*Not used in FY 2011.

CO₂ Pipeline Route

A review of known or suspected environmental conditions along the proposed CO₂ pipeline route identified three EPA-regulated contaminated sites, listed in Table 3.12-2 (CH2M Hill 2011). No evidence of past or current facilities that generate, treat, store, or dispose of hazardous materials, non-hazardous waste, or hazardous waste was identified along the proposed CO₂ pipeline route.

Table 3.12-2 EPA-Regulated Contaminated Sites along the Proposed Pipeline Route

Site Name	MP	Distance to Workspace (feet)
Millennium Power	0.4	740
Millennium Power	0.5	910
Millennium Power	1.3	210

Hastings Oil Field

The Hastings oil field has a long history of activity, starting with primary oil production and progressing to a secondary water flood and pressure maintenance program (THSA 2011), and the current commercial EOR activities. No hazardous waste sites or spills were identified within the West Hastings research MVA site boundary (EPA 2011). Denbury is reconverting or reworking

a number of wells in the Hastings oil field that will be used for the West Hastings MVA program, commercial injection of CO₂, production of oil and gas, and produced water disposal. Denbury uses a closed-loop drilling system and disposes of drilling mud and associated wastes generated during drilling at an approved commercial disposal facility.

3.13 Human Health and Safety

This section describes the existing characteristics of the area of the LCCE Gasification plant in Calcasieu Parish, Louisiana, and the portion of the Lake Charles CCS project in Calcasieu Parish, Louisiana, and Brazoria County, Texas, as they relate to human health. Human health and safety typically considers the potential hazards to workers and the public. This section presents information on populations that could be exposed to potential hazards during construction or operation of the proposed project or connected action.

Lake Charles, Louisiana

The area surrounding the LCCE Gasification plant and Lake Charles CCS project is primarily used for heavy industrial operations. Adjoining and surrounding properties are occupied by the Citgo refinery, the City of Sulphur wastewater treatment plant, Haliburton, Louisiana Pigment Company, Basell USA, the Port of Lake Charles Bulk Terminal No. 1, and the Lake Charles Coke Handling Terminal (jointly owned and operated by ConocoPhillips and CITGO Petroleum Corporation).

The U.S. Bureau of Labor Statistics (USBLS) provides data on workplace incidents for various industries. Table 3.13-1 presents occupational injury and fatality data for non-residential construction, oil and gas pipeline construction, natural gas pipeline transportation, and petroleum refineries. The rates are expressed in terms of injuries/illnesses per 100 worker-years (or 200,000 hours) for total recordable cases and total cases with lost work day, days away, job transfer or restriction. Fatalities are based on 100,000 workers.

Table 3.13-1 Occupational Injury and Fatality Rate Data For Related Industries

Industry (NAICS code)	2011 Average Annual Employment (thousands)	Total Recordable Case Rate (per 100 workers)	Total Cases with days away from work, job transfer, or restriction	Fatality Rate Per 100,000 FTE Workers
Non-residential construction (2362)	650.4	3.1	1.7	3.8
Oil and gas pipeline and related structures construction (23712)	101.0	1.3	0.7	11.5
Pipeline Transportation (486)	41.7	1.5	1.2	7.3
Petroleum Refineries (32411)	69.9	1.1	0.6	2.7

No schools, churches, or hospitals are located within 2 miles of the LCCE Gasification plant or Lake Charles CCS CO₂ Capture and Compression facilities. The nearest residential zoned area is approximately 1 mile to the east, across the Calcasieu River and Prien Lake. However, a few

residences are located approximately 0.75 miles north of the proposed site and north of the Louisiana Pigment plant. The largest population area near the project site is the city of Lake Charles, Louisiana, approximately 1 mile from the site, across the Calcasieu River. The next nearest large population areas, both with more than 50,000 residents, are the cities of Beaumont, Texas, and Lafayette, Louisiana, which are approximately 70 and 60 miles from the site, respectively. Smaller cities and communities within 2 miles of the project site include Sulphur, Prien, Carlyss, and Westlake, Louisiana (www.city-data.com 2011).

Table 3.13-2 provides a summary of the population and sensitive receptor information from the 2010 U.S. Census for the census tracts located within 1 mile of the LCCE Gasification plant. Sensitive receptors include young children, the elderly, and those living in poverty (inadequate access to healthcare).

CO₂ Pipeline Route

The proposed CO₂ pipeline would transport supercritical CO₂ from the LCCE Gasification Project to the existing independent Green Pipeline. The proposed route is located in a rural, sparsely populated area; eight residences were identified within 50 feet of the ROW.

Table 3.13-3 provides a summary of the population and sensitive receptor information from the 2010 U.S. Census for the census tracts located within 1 mile of the CO₂ pipeline corridor. One school and a church are located near the eastern limit of the ROW. No other sensitive receptors are located within the 1 mile pipeline corridor.

Hastings Oil Field, Texas

As part of ongoing commercial EOR activities, Denbury currently injects CO₂ for commercial EOR at the Hastings oil field. The cities of Alvin and Pearland are located approximately 4 miles south and three miles north, respectively, of the Hastings oil field. These cities have populations of more than 25,000 and are located approximately 4 miles south and three miles north, respectively from the West Hastings research MVA site, with outlying subdivisions and residential areas nearer to the site. Land use within Hastings oil field includes farmland, rural development, and recreational, commercial, and residential areas. Commercial development is concentrated along State Highway 35.

Table 3.13-2 Population Characteristics of Sensitive Receptors Within 1 Mile of the LCCE Gasification Plant

Geography	Total Population (2010)	Percent of Population below the Poverty Level (2009) ¹	Population Density (2010)	Percent Children under 5 years old (2010)	Percent Adults 65 and older (2010)
State of Louisiana	4,533,372	18.7	104.9	6.9	12.3
Calcasieu Parish	192,768	16.5	181.2	7.1	12.9
City of Sulphur	20,410	15.3	2042.8	7.6	14.3
Study Area	772	7.6	148.1	4.4	11.5
Census Tract 32	2,167	6.8	29.7	7.4	9.5
Block Group 1065	4	NA	2.2	0.0	100
Block Group 1075	41	NA	86.4	9.8	7.3
Block Group 1077	3	NA	1.35	0.0	33.3
Census Tract 18.01	10,014	5.3	250.4	7.2	8.4
Block Group 2003	715	NA	645	4.2	11.2
Block Group 2017	9	NA	5.6	0.0	11.1

Source: USCB 2009, 2010.

¹ Population below the poverty level is not available for census block groups; therefore, the percent population below the poverty level for study area consists of data for respective census tracts.

Table 3.13-3 Population Characteristics of Sensitive Receptors Within 0.5 Miles of the Proposed CO₂ Pipeline

Geography	Total Population (2010)	Percent of Population below the Poverty Level (2009) ¹	Population Density (per sq mile) (2010)	Percent Children under 5 years old (2010)	Percent Adults 65 and older (2010)
State of Louisiana	4,533,372	18.7	104.9	6.9	12.3
Calcasieu Parish	192,768	16.5	181.2	7.1	12.9
City of Sulphur	20,410	15.3	2042.8	7.6	14.3
Study Area	5,629	13.2	1,352	6.5	12.4
Census Tract 23	2,835	11.5	29.8	6.6	14.0
Block Group 1001	43	NA	109.9	9.3	7.0
Block Group 1020	107	NA	11.4	3.7	15.0
Block Group 1027	132	NA	85.7	9.1	6.8
Block Group 1028	63	NA	36.7	0.0	28.6
Block Group 1029	27	NA	578.8	3.7	18.5
Block Group 1033	78	NA	153.0	7.7	14.1
Block Group 1034	20	NA	2248	10	0.0
Block Group 1035	49	NA	210.8	6.1	4.0
Block Group 1036	4	NA	1269	0.0	0.0
Block Group 1037	5	NA	181.5	0.0	0.0
Block Group 1039	15	NA	43.7	6.7	6.7
Block Group 1098	701	NA	250.6	5.3	8.6
Block Group 1102	164	NA	164.2	12.2	4.9
Block Group 1107	103	NA	2947	0.0	9.3
Block Group 1108	12	NA	34.5	16.7	0.0
Block Group 1109	26	NA	30.1	7.7	7.7
Block Group 1110	48	NA	18.7	2.1	31.3
Block Group 1120	48	NA	233.0	14.6	8.3
Block Group 2012	44	NA	44.9	4.5	13.6
Block Group 2014	3	NA	100.5	0.0	0.0
Census Tract 27	8,352	21.5	111.4	7.0	10.3
Block Group 1001	43	NA	109.9	9.3	7.0
Block Group 1005	3	NA	215.4	0.0	0.0
Block Group 1013	43	NA	113.2	4.7	9.3
Block Group 1016	99	NA	111.3	6.1	13.1
Block Group 1020	508	NA	86.8	9.6	7.3

Table 3.13-3 Population Characteristics of Sensitive Receptors Within 0.5 Miles of the Proposed CO₂ Pipeline

Geography	Total Population (2010)	Percent of Population below the Poverty Level (2009) ¹	Population Density (per sq mile) (2010)	Percent Children under 5 years old (2010)	Percent Adults 65 and older (2010)
Block Group 1059	55	NA	122.4	3.6	21.8
Block Group 2012	44	NA	44.9	4.5	13.6
Block Group 2014	3	NA	100.5	0.0	0.0
Block Group 2017	157	NA	1032	1.3	17.2
Block Group 2018	61	NA	200.6	8.2	13.1
Block Group 2022	67	NA	1116	6.0	22.4
Block Group 2024	81	NA	50.9	11.1	9.9
Block Group 2029	6	NA	40.9	16.7	16.7
Block Group 2032	22	NA	7192		
Block Group 2033	119	NA	2125	10.9	9.2
Block Group 2034	18	NA	4153	5.6	5.6
Block Group 2035	6	NA	1100	0.0	33.3
Block Group 2037	8	NA	67.9	0.0	0.0
Block Group 2039	81	NA	214.1	4.9	18.5
Block Group 2040	71	NA	218.4	11.3	11.3
Census Tract 31.02	2,282	5.9	2,479	6.6	11.5
Block Group 1001	61	NA	652.5	6.6	18.0
Block Group 1002	20	NA	4872	5.0	5.0
Block Group 1003	29	NA	4205	3.4	6.9
Block Group 1004	25	NA	2755	8.0	0.0
Block Group 1005	54	NA	3833	5.6	7.4
Block Group 1011	144	NA	1737	4.9	11.1
Block Group 1012	72	NA	6595	8.3	9.7
Block Group 1013	82	NA	3535	4.9	11.0
Block Group 1014	41	NA	1320	2.4	19.5
Block Group 1015	112	NA	556.8	8.0	10.7
Block Group 1016	57	NA	5644	7.0	17.5
Block Group 1017	51	NA	4010	2.0	13.7
Block Group 1018	44	NA	3648	4.5	22.7
Block Group 1022	93	NA	3431	7.5	12.9
Block Group 1023	83	NA	5852	7.2	2.4

Table 3.13-3 Population Characteristics of Sensitive Receptors Within 0.5 Miles of the Proposed CO₂ Pipeline

Geography	Total Population (2010)	Percent of Population below the Poverty Level (2009)¹	Population Density (per sq mile) (2010)	Percent Children under 5 years old (2010)	Percent Adults 65 and older (2010)
Census Tract 32	2,167	6.8	29.7	7.4	9.5
Block Group 1011	114	NA	1,737	4.9	11.1
Block Group 1015	112	NA	557	8.0	10.7
Block Group 1016	2	NA	27.3	0.0	100
Block Group 1018	54	NA	30.4	3.7	18.5
Block Group 1065	4	NA	2.2	0.0	100
Block Group 1067	21	NA	596	2.4	4.8
Block Group 1075	41	NA	86.4	9.8	7.3
Block Group 1077	3	NA	1.4	0.0	33.3
Block Group 1114	25	NA	83.3	8.0	16.0
Block Group 1147	59	NA	4,246	8.5	1.7
Block Group 1148	181	NA	1,881	10.5	3.3
Block Group 2039	81	NA	214	4.9	18.5

Source: USCB 2009, 2010.

¹ Population below the poverty level is not available for census block groups; therefore, the percentage of population below the poverty level for the study area consists of data for respective census tracts.

This page left blank intentionally.

4. Environmental Consequences

4.1 Introduction

This chapter describes the potential direct and indirect environmental impacts that would likely result from the proposed project and connected action described in Chapter 2. The principal alternatives are the proposed project and connected action, as modified by design and operating standards or required mitigation, and the no-action alternative. This chapter also considers project design alternatives and the potential impacts or effects of these alternatives as well as mitigation measures that may be considered by DOE. This chapter is organized as follows:

- Air Quality and Climate (Section 4.2)
- Geology and Soils (Section 4.3)
- Surface Water, Wetlands, and Floodplains (Section 4.4)
- Groundwater (Section 4.5)
- Biological Resources (Section 4.6)
- Cultural Resources (Section 4.7)
- Land Use (Section 4.8)
- Socioeconomic and Environmental Justice (Section 4.9)
- Traffic and Transportation (Section 4.10)
- Noise (Section 4.11)
- Waste Management (Section 4.12)
- Materials (Section 4.13)
- Human Health and Safety (Section 4.14)
- Accident Analyses (Section 4.15)

Each section of this chapter addresses potential impacts on that environmental resource area relative to the baseline conditions described in Chapter 3.

The scope of this EIS includes the construction and operation of the LCCE Gasification plant, including related off-site activities, and the Lake Charles CCS project. The construction laydown area, which would be converted to the methanol and sulfuric acid storage area for operation, would be located a short distance from the LCCE Gasification plant site. Leucadia is in the process of identifying and leasing a parcel of up to 40 acres using the siting criteria described in Section 2.3.1. To minimize the length of the methanol and sulfuric acid pipeline route, the selected storage site would be within 1 mile of the LCCE Gasification plant. DOE used knowledge of the area in the vicinity of the LCCE Gasification plant site to evaluate potential impacts (e.g., zoning, floodplains, air quality) of the equipment laydown area. Thus, the exact location of the equipment laydown and methanol/sulfuric acid storage area would have minor relevance to the evaluation of reasonably foreseeable adverse impacts on the environment.

Where possible, DOE quantified the potential impacts associated with the proposed action and the connected action. In some cases, it is not possible to quantify impacts; in those cases, a qualitative assessment of potential impacts is presented. The following descriptors are used qualitatively to characterize impacts:

- **Beneficial:** impacts would improve or enhance the resource.

- **Negligible:** no apparent or measurable adverse impact expected or temporary impacts may not be measurable or are not perceptible.
- **Minor:** barely noticeable or measurable adverse impacts on the resource would be expected.
- **Moderate:** noticeable or measurable adverse impacts on the resource would be expected. Mitigation measures would usually be considered for these impacts.
- **Substantial impact:** potential adverse effects that could result in potentially significant impacts despite mitigation measures.

4.2 Climate and Air Quality

4.2.1 Factors Considered for Assessing Impacts

DOE assessed air pollutant emissions generated by construction and operation activities for potential impacts on air quality based on the potential direct or indirect consequences of the proposed project or connected action. Potential direct or indirect consequences include the following:

- Emissions of criteria air pollutants or hazardous air pollutants;
- Changes in air quality related to the National Ambient Air Quality Standards (NAAQS) or Louisiana Ambient Air Standards;
- Increases in ground-level concentrations of hazardous air pollutants;
- Reduction in visibility and increase in regional haze in Class I areas;
- Deposition of nitrogen and sulfur in Class I areas;
- Conflict with or obstruction of implementation of applicable air quality management plans;
- Emissions of greenhouse gases;
- Solar loss, fogging, icing, or salt deposition on nearby residences;
- Discharge of odors to the air; or
- Net increases of any criteria pollutant for which the region of the proposed action is considered non-attainment under an applicable federal or state ambient air standard.

Because climate change impacts are an inherently cumulative effect rather than a direct effect of the proposed project, a review of global, regional, and local greenhouse gas emissions and regulatory developments are discussed in Chapter 5, “Cumulative Impacts.”

4.2.2 LCCE Gasification (Connected Action)

4.2.2.1 Construction

4.2.2.1.1 Gasification Plant

Emissions produced during construction primarily consist of exhaust emissions from construction-related equipment and dust generated during soil-disturbing activities. The estimate of construction emissions is based on the type of equipment, size, fuel type, and duration of use required to construct the LCCE Gasification plant and the Lake Charles CCS project CO₂ capture and compression facilities. The estimate uses emission factors from the EPA Emission Factor document AP-42, and includes emissions from non-road equipment and vehicles; on-road vehicles associated with construction, such as worker commuting vehicles (e.g., passenger cars and pick-up trucks/SUVs); medium-size delivery trucks; and tractor-trailer trucks as described in Section 2.4.1.1. Table 4.2-1 summarizes these emission estimates.

Table 4.2-1 Construction Emissions LCCE Gasification Plant and Lake Charles CSS Project CO₂ Capture and Compression Facilities (tons per year)

Emission Source	Pollutant					
	NO _x	SO ₂	CO	VOCs	PM ₁₀ /PM _{2.5}	CO ₂
Construction Equipment	351	23	76	29	25	13,112
Worker Vehicles	11	NP	138	14	>0.1	NP
Delivery Vehicles	0.6	NP	0.2	>0.1	>0.1	NP
Total	363	23	214	43	25	13,112

Source: Leucadia Energy 2011.

Key:

- CO = carbon monoxide
- CO₂ = carbon dioxide.
- NO_x = nitrogen oxides
- NP = not provided
- PM₁₀/PM_{2.5} = particulate matter smaller than 10 microns/2.5 microns in diameter
- SO₂ = sulfur dioxide
- VOCs = volatile organic compounds

Air pollutant emissions from construction of the off-site pipelines and CO₂ pipelines would likely occur simultaneously for a three month period and overlap with the LCCE Gasification plant and Lake Charles CCS project 40 month construction and commissioning schedule.

In addition, due to the dispersed nature of the mobile sources during construction period, it is not expected that emissions would concentrate in a specific area and expose sensitive receptors to substantial pollutant concentrations. Construction would not result in a significant increase in CO₂ emissions to the atmosphere; the emissions are temporary and would cease after completion of construction and estimated annual CO₂ emissions are well below comparative thresholds for permitting stationary sources for GHGs. Leucadia would operate and maintain construction equipment in accordance with manufacturers' recommendations. Leucadia would use best management practice (BMPs) to control the dust generated by construction activities with dust-suppression techniques (e.g., application of water to exposed soil). Therefore, the potential emissions from construction of the LCCE Gasification plant and the CCS project would result in a temporary and negligible impact on air quality.

4.2.2.1.2 Off-Site Activities

Emissions due to construction of the parking area for construction-related vehicles; the areas for equipment laydown and methanol/sulfuric acid storage; and linears for natural gas, potable water, electricity transmission, sulfuric acid, and methanol pipelines are included in the emission estimates shown in Table 4.2-1.

Construction of the water supply and hydrogen pipelines would require use of equipment similar to equipment used for constructing the CO₂ pipeline (see Section 4.2.3.2.1 below). Construction emissions would have direct impacts on air quality during periods of construction. However, emissions are temporary, would not affect any one area for more than a day or two since the pipeline construction spread will proceed along the pipeline right-of-way, and the emissions would cease after construction is completed. The emission estimates for water and hydrogen pipeline construction were based on their lengths relative to the length of the CO₂ pipeline and its construction emissions. The water pipeline would be 4 miles long; the hydrogen pipeline would be 8.5 miles long. Table 4.2-2 shows estimated emissions for construction of the water and hydrogen pipelines. To minimize potential emissions, Leucadia would operate and maintain construction equipment in accordance with manufacturers’ recommendations. Leucadia would also control the dust generated with dust-suppression techniques such as application of water to exposed soil.

Table 4.2-2 Construction Emissions LCCE Gasification Water and Hydrogen Pipeline (tons)

Activity	NO _x	SO _x	VOCs	CO	PM ₁₀ /PM _{2.5}	CO ₂ e	HAPs
Water Pipeline	40	0.6	2.7	8.6	245	3,080	0.07
Hydrogen Pipeline	86	1.2	5.7	18	521	6,544	0.15

Criteria pollutants, GHG and hazardous air pollutant emissions for construction-phase combustion estimated by ratio of pipeline length to length of CO₂ pipeline and emission s provided by Denbury for the CO₂ pipeline (see Section 4.2.3.2.1).

Key:

- CO = carbon monoxide
- CO₂e = carbon dioxide equivalent
- HAPs = hazardous air pollutants
- NO_x = nitrogen oxides
- PM₁₀/PM_{2.5} = particulate matter smaller than 10 microns/2.5 microns in diameter
- SO₂ = sulfur dioxide
- VOCs = volatile organic compounds

4.2.2.2 Operation

4.2.2.2.1 Gasification Plant

Leucadia received the initial Title V and PSD permit for Lake Charles Cogeneration, LLC on June 22, 2009. A minor modification was made to the Title V and PSD permit effective December 30, 2010. This modification incorporated a change in the process from producing synthetic natural gas to producing methanol. The Title V and PSD permit were also modified to reflect the addition of hydrogen production to the facility design. The modified permit was effective as of June 29, 2012 (PSD-LA-742 and 0520-00411-V0). Tables 4.2-3 and 4.2-4 summarize the criteria and toxic air pollutant (TAP) emission values based on the initial permit and the two subsequent modifications. An estimate of greenhouse gas (GHG) emissions was included in the second modified permit to demonstrate an overall decrease in CO₂ emissions with the design modifications.

The LDEQ reviewed the emissions shown in Tables 4.2-3 and 4.2-4 as part of the air permit application review process conducted under Louisiana air permitting regulations. In addition, the LDEQ reviewed and approved the air quality modeling protocols and impact modeling performed by Leucadia. Leucadia completed air dispersion modeling in support of the initial air permit application for criteria pollutants and TAPs (H₂SO₄, H₂S and COS). The modeling used AERMOD, an approved EPA dispersion model for the criteria pollutants and Industrial Source Complex Short Term (ISCST) model for the TAPs. For all criteria pollutants, maximum modeled concentrations in ambient air due to the proposed facility emissions were below (i.e., better than) federal and Louisiana ambient air standards. Modeling was not repeated for the first or second permit modifications because potential emissions did not change or were lower. Ammonia emissions were modeled for the second permit modification because of the increase in potential emissions. Table 4.2-5 summarizes the dispersion model results for criteria pollutants and TAPs from the current Title V and PSD permit (June 29, 2012). The LDEQ concluded that the proposed emissions, when dispersed into the atmosphere, would not cause or contribute to any violation of the Louisiana ambient air standards. All maximum ground-level concentrations are below PSD modeling significance levels, indicating that, in accordance with EPA New Source Review guidance, refined analyses for PSD increment consumption is not required.

Table 4.2-3 also presents an estimate of GHG emissions for the LCCE Gasification plant and the Lake Charles CCS project CO₂ capture and compression facilities. CO₂ would be generated during the production of hydrogen and methanol. The CO₂ is separated out with the following approximate percentage distribution: 89% captured and compressed in the CO₂ compressor; 3% captured/converted to methanol; 3% emitted to the atmosphere through the tailgas (combustor) stack; and 5% emitted to the atmosphere through the WSA acid gas stack. The permit value for CO₂e reflects that the 89% CO₂ captured in the AGR process is vented through a regenerative thermal oxidizer instead of being captured.

Leucadia assessed the potential for Class I area impacts by first evaluating the distance from the facility to the nearest Class I area. The nearest Class I area is the Breton National Wildlife Refuge; the distance to Breton from the facility is approximately 400 kilometers (249 miles). This distance is well beyond the 100-kilometer (62-mile) distance threshold noted in the EPA guidance document "Draft New Source Review Workshop Manual" (October 1990) and also beyond a 200-kilometer (124-mile) threshold distance that is applied to larger emission sources on a case-by-case basis. Leucadia also indicated in its initial Title V and PSD permit application study that the Federal Land Manager (FLM) was notified of the project. LDEQ advised Leucadia that no further action was required with regards to Class I areas. Because the distance between the LCCE Gasification plant and the nearest Class 1 area is four times the distance threshold, a reduction in regional visibility, increase in regional haze, and increases in nitrogen and sulfur deposition in the nearest Class I area would be highly unlikely.

Table 4.2-3 Operation Criteria Pollutant Emissions for the LCCE Gasification Plant and Lake Charles CSS Project CO₂ Capture and Compression Facilities (tons per year)

Emission Source	NO _x	SO ₂	CO	CO ₂ e	VOCs	PM/PM ₁₀	PM _{2.5}
LCCE Gasification	166	132	524	5,840,387	14	76 (see note)	69 (see note)

Source: Leucadia Energy 2011, 2012 PSD-LA-742 and 0520-00411-V0 to construct and operate a new facility pursuant to the prevention of significant deterioration regulations and state preconstruction and Part 70 operating permit.

Note: Initial and first minor modification Title V and PSD permits did not count sulfuric acid emissions as condensable particulates in PM₁₀ and PM_{2.5} totals. For the second permit modification, sulfuric acid emissions were included as condensable particulates in PM₁₀ and PM_{2.5} totals. CO₂e was not reported in the initial Title V and PSD permit because regulations requiring inclusion were not in place. CO₂e emissions also were not reported in the first permit modification; however, the second permit modification provided values “before and after” modification for comparison.

Key:

- CO = carbon monoxide
- CO₂e = carbon dioxide equivalent
- NO_x = nitrogen oxides
- PM₁₀/PM_{2.5} = particulate matter smaller than 10 microns/2.5 microns in diameter
- SO₂ = sulfur dioxide
- VOCs = volatile organic compounds

Table 4.2-4 Operation Toxic Air Pollutant Emissions LCCE Gasification and Lake Charles CSS Project CO₂ Capture and Compression Facilities (tons per year)¹

Emission Source	Sulfuric Acid	Methanol	Carbonyl Sulfide	Ammonia	Hydrogen Sulfide	Other ²	Total ³
LCCE Gasification	57	9	1	35	1	<0.01	102

¹ As defined in LAC 33:III, Chapter 51, Regulated Toxic Air Pollutants (TAP).

² Includes benzene, toluene, ethyl benzene, xylenes, n-hexane and cumene.

³ Total may not match due to rounding.

Table 4.2-5 Air Dispersion Modeling Results LCCE Gasification

Pollutant	Averaging Period	Calculated Maximum Ground-Level Concentration (µg/m ³)	PSD Modeling Significance Level (µg/m ³)	NAAQS (µg/m ³)	Louisiana AAS (µg/m ³)
PM/PM ₁₀	24 hour	2.63	5	150	-
	Annual	0.44	1	50	-
SO ₂	3 hour	24.05	25	1300	-
	24 hour	4.65	5	365	-
	Annual	0.64	1	80	-
NO _x	Annual	0.95	1	100	-
CO	1 hour	81.87	2,000	40,000	-
	8 hour	50.1	500	10,000	-
H ₂ SO ₄	8 hour	13.36	-	-	23.8
H ₂ S	8 hour	14.72	-	-	330
COS	8 hour	0.107	-	-	582
NH ₃	8 hour	7.91	-	-	640

Source: Lake Charles Clean Energy LLC Air Permit 0520-00411-V2, June 29, 2012; Lake Charles Cogeneration, LLC, Title V and PSD Study (September 2008).

Key:

- µg/m = micrograms per cubic meter
- AAS = ambient air standards

Solar loss, fogging, icing, or salt deposition on nearby residences could be associated with operation of the cooling tower. The Title V and PSD permit requires mist eliminators for the cooling tower to minimize drift of water droplets that would otherwise lead to solar loss, create fogging, and result in salt deposition. Given the location of the project in the warm climate along the Gulf Coast, icing conditions are highly unlikely to occur. In addition, the permit requires opacity to be less than or equal to 20% except for an allowance of exceeding 20% opacity for no more than one 6-minute period per 60-minute interval.

Leucadia's Title V permit incorporates by reference the Louisiana Administrative Code Title 33 (Environmental Quality), Part III (Air), Chapter 29 (Odor Regulations). Thus, compliance with the Title V permit would minimize the impact of any odor emissions on locations beyond the facility boundary.

Leucadia would operate in accordance with the Title V and PSD air permit (June 29, 2012) and any subsequent modifications. In issuing the permit, LDEQ determined that the proposed emissions would not cause or contribute to any violation of the NAAQS or Louisiana ambient air standards or expose sensitive receptors to substantial pollutant concentrations. Therefore, the potential emissions from operation of the LCCE Gasification plant and the Lake Charles CCS project would result in a minor impact on air quality.

4.2.2.2.2 Off-Site Activities

Use of the construction parking area would cease when construction is completed. Vehicles used for operation and maintenance would produce negligible emissions at the equipment laydown and methanol/sulfuric acid storage area, the natural gas, potable water, electricity transmission, sulfuric acid and methanol linears, and the water supply and hydrogen pipelines and would have negligible impacts on air quality.

DOE also considered the emissions impacts from transport of approximately 2.6 million tons per year of petroleum coke to the LCCE Gasification plant. Leucadia estimates that approximately 20% (0.5 million tons per year) of the petroleum coke will be locally sourced (i.e., come from locally produced petroleum coke already arriving at the Port of Lake Charles). Transport of petroleum coke from local sources to the Port of Lake Charles would not change as a result of construction of the LCCE Gasification plant. The only change would be the diversion at the Port of Lake Charles of 0.5 million tons per year of petroleum coke for use by LCCE Gasification rather than being shipped elsewhere. The transport of petroleum coke in this case will not result in additional emissions; instead, emissions from vessels due to shipment of 0.5 million tons per year of petroleum coke to other ports would be eliminated.

The remaining 80% of the petroleum coke needed for the LCCE Gasification plant (approximately 2.1 million tons per year) would primarily come from other ports in the U.S. Gulf of Mexico (USGM) region. The petroleum coke used by the LCCE Gasification plant from other ports in the USGM would not result from increased petroleum coke production but instead would divert petroleum coke from shipments normally destined for overseas ports. Leucadia identified sources of petroleum coke shipping from five USGM ports and the distance between the Port of Lake Charles and the ports as follows:

- Pascagoula, Mississippi (360 nautical miles)
- New Orleans, Louisiana (294 nautical miles)
- Port Arthur, Texas (70 nautical miles)
- Houston, Texas (137 nautical miles)
- Corpus Christi, Texas (271 nautical miles)

These five ports routinely ship petroleum coke as part of existing normal commerce to foreign ports. The coke is currently loaded onto ocean-going vessels, escorted from each port with the use of tug boats until the vessels can make way on their own propulsion systems. Petroleum coke would be loaded onto barges and moved to the LCCE Gasification plant using conventional (harbor) tugs and ocean-going tugs. By diverting shipment of the petroleum coke from foreign ports to the Port of Lake Charles and reducing the length of the trip, emissions from vessels will be reduced. For example, Leucadia estimated that shipping 2.1 million tons of petroleum coke to LCCE Gasification instead of shipping to foreign ports will reduce CO₂ transport emissions by approximately 95% (from approximately 100,000 tons of CO₂ per year to approximately 5,000 tons of CO₂ per year(Leucadia 2012x).

Petroleum coke received at the Port of Lake Charles would be transferred to the Port's material handling system. The Port of Lake Charles would be used for petroleum coke and bulk handling transport needs and petcoke would be transferred to the LCCE Gasification plant via a state-of-the-art conveyor system to storage silos. Dust emissions associated with transport within the LCCE Gasification plant site are regulated by the Title V permit. Dust emissions associated with handling the petroleum coke within the boundaries of the Port of Lake Charles would be the responsibility of the Port and would be regulated by any air operating permit governing operations at the Port.

4.2.3 Lake Charles CCS Project

4.2.3.1 CO₂ Capture and Compression Facilities

4.2.3.1.1 Construction

Emissions from construction of the CO₂ capture and compression facility are included in the overall construction emission estimate for the LCCE Gasification plant (connected action) shown in Table 4.2-1.

4.2.3.1.2 Operation

Pumps and compressors within the CO₂ capture and compression facility would be electrically driven and generate no direct emissions to the atmosphere. Ancillary systems supporting the CO₂ capture and compression facility that are within the LCCE Gasification plant will generate direct emissions. Emissions from these ancillary systems are included in the LCCE Gasification emission inventory and air permit, as summarized in Tables 4.2-3 and 4.2-4. The inclusion of these emissions with the Title V and PSD permit regulating the facility subjects them to various emission limits and compliance requirements. In addition, the emissions were included in the dispersion modeling analysis, the results of which are summarized in Table 4.2-5. The Lake Charles CCS CO₂ Capture and Compression equipment is estimated to use approximately 705,000 megawatt-hours per year (MWh/year) of electricity for this purpose (Leucadia 2012). Indirect emissions associated with the generation of this quantity of electricity are shown in Table 4.2-6.

Table 4.2-6 Indirect Emissions from Electricity Use in the CO₂ Capture and Compression Facility

Electric Use (MWh)	NO _x (tpy)	SO ₂ (tpy)	CO ₂ e (tpy)
705,000	423	564	355,320
Emission factors (2007)	1.2 lbs/MWh	1.6 lbs/MWh	1,008 lbs/MWh

Emission factors from: USDOE EIA eGRID 2010 version 1.1, Year 2007 Summary Tables, (created May 2011).

Key:

- CO₂e = carbon dioxide equivalent
- NO_x = nitrogen oxides
- SO₂ = sulfur dioxide
- Tpy = tons per year
- Lbs/MWh = pounds per megawatt-hour

4.2.3.2 CO₂ Pipeline

4.2.3.2.1 Proposed Route

Construction

Emissions generated during construction of the pipeline would occur primarily from the use of bulldozers, cranes, backhoes, tractor-trailer trucks, dump trucks, and pickup trucks and, at certain locations, drilling equipment that would be used to install pipe. Table 4.2-7 provides estimates of construction-related air pollutant emissions during construction of the CO₂ pipeline. PM emissions from dust generated by soil disturbance and equipment movement over unpaved surfaces during the construction phase were estimated using EPA AP-42 emission factors for heavy construction operations (EPA AP-42, Chapter 13.2.3). Approximately three months would be required to build the pipeline, and 187 acres would be disturbed. The combustion equipment emissions estimates are based on equipment ratings, quantity, and type of equipment, and duration of use.

Table 4.2-7 CO₂ Pipeline Construction Emissions (tons)

Activity	NO _x	SO _x	VOCs	CO	PM ₁₀ /PM _{2.5}	CO ₂ e	HAPs
Equipment Exhaust	112	1.6	7.5	24	6.7	8,546	0.2
Dust	-	-	-	-	673	-	-
Total	112	1.6	7.5	24	680	8,546	0.2

Notes:

1. Criteria pollutant emissions for construction-phase combustion provided by Denbury.
2. PM emissions from construction-phase dust were estimated using AP-42, Chapter 13.2.4
3. GHG emissions were estimated using methodologies provided in API Compendium of Greenhouse Gas Emissions Methodologies for the Oil and Natural Gas Industry, August 2009.
4. HAP emissions from construction equipment combustion were estimated using AP-42, Chapter 3, for internal combustion, and Table 3.3-1 for diesel fuel.

Key:

- CO = carbon monoxide
- CO₂e = carbon dioxide equivalent
- HAPs = hazardous air pollutants
- NO_x = nitrogen oxides
- PM₁₀/PM_{2.5} = particulate matter smaller than 10 microns/2.5 microns in diameter
- SO₂ = sulfur dioxide
- VOCs = volatile organic compounds

The emissions from construction of the Lake Charles CCS CO₂ pipeline may coincide in time with construction of the LCCE Gasification plant water supply and hydrogen pipelines. In addition, due to the dispersed nature of the mobile sources during the construction period, it is not expected that emissions would concentrate in a specific area and expose sensitive receptors

to substantial pollutant concentrations. Denbury would implement BMPs to minimize dust emissions during construction of the CO₂ pipeline using typical dust-control techniques, including:

- Watering, chemical stabilization, or reduction of surface wind speed with windbreaks or source enclosures;
- Minimizing mud/dirt carryout on paved roads
- Cleaning up spills on paved and unpaved travel surfaces.

Proper maintenance of the combustion equipment is the most effective method to minimize combustion emissions from construction equipment. Denbury would operate and maintain construction equipment in accordance with manufacturers' recommendations and Louisiana regulations. Reducing equipment engine idle time and using lower-emission fleet vehicles can also reduce emissions. The construction emissions will have temporary and negligible impacts on air quality as the pipeline construction spread proceeds along the pipeline right-of-way. The emissions would cease after construction is completed.

Operation

The pipeline would be underground throughout its length, and no stationary point emission sources would be associated with pipeline operation. Aboveground facilities would consist of a valve site and meter station. Vehicles used during inspections and maintenance would produce a negligible amount of emissions. Denbury would operate and maintain vehicles in accordance with manufacturers' recommendations. Fugitive emissions would occur during routine pipeline operation, primarily due to minor leaks from pipeline flanges and valves at the valve site and meter station. Fugitive emissions of CO₂ from the pipeline would be below applicable regulatory thresholds.

4.2.3.2.2 Alternative Route B

The air quality impacts from construction of the CO₂ pipeline along Alternative Route B would be similar to those of the proposed CO₂ pipeline route. The alternative pipeline route is 0.3 miles shorter than the proposed route but the ROW is the same as the proposed route and therefore emissions would be essentially the same as for the proposed pipeline.

4.2.3.3 West Hastings Research MVA

Implementation of the West Hastings research MVA program would use drilling equipment (workover rig) to plug back, recondition, and recomplete existing wells as described in Section 2.4.3, perform downhole log surveys, and install monitoring sensors. The emissions from the well reconditioning and downhole surveys would occur from two general types of sources: material handling and burning of fuel by mobile sources (APCI 2011). Preparing a pre-existing well pad for the MVA wells could involve activities such as site grubbing and clearing. Other emissions may include entrained dust from equipment traveling on unpaved roads and unpaved surfaces in existing well pad areas (APCI 2011). Material-handling activities would result in emissions of PM_{2.5}.

Mobile source emissions would result from the burning of fuels (gasoline and diesel) during the use of vehicles and equipment (e.g., the workover rig). These emissions would include NO_x,

VOCs, CO, SO₂, and PM_{2.5}. On-road vehicles including heavy- and light-duty vehicles would be used during well conversion activities and during enhancement of existing well pads. These activities would occur for approximately three to four weeks at each well location. The plugging, reconditioning, and recompleting of existing wells for the West Hastings research MVA program would result in temporary, negligible impacts on air quality.

4.2.4 Conformity Analysis

Section 176 of the 1990 federal Clean Air Act amendments required the EPA to promulgate rules to ensure federal actions conform to the appropriate state implementation plan (SIP). These rules, known together as the General Conformity Rule (40 CFR 93.150-165), require any federal agency responsible for an action in a nonattainment area or air quality planning area subject to a maintenance plan to determine whether the action conforms to the applicable SIP or is exempt from the General Conformity Rule requirements. The General Conformity Rule applies only to emissions caused by federal actions that occur in a federal nonattainment area or an area subject to a maintenance plan during the 10-year period of the maintenance plan (see Section 3.2.2 for more information on these designations). Further, only emissions that equal or exceed the General Conformity Rule's *de minimis* thresholds would require the need for a General Conformity determination. A federal action includes the action of providing funding for a project. By rule, any portion of an action that includes stationary sources permitted under the prevention of significant deterioration (PSD) program does not require a General Conformity determination (40 CFR 93.153 (d) (1)). The LCCE Gasification plant, which includes the Lake Charles CCS project, requires a permit under the PSD program and is therefore exempt from a General Conformity determination for the operations phase. DOE evaluated the impact of construction phase emissions from the proposed project (Lake Charles CCS project) that DOE would fund and the connected action (LCCE Gasification plant) that DOE would not fund, because together they make a complete air emission source.

As described in Section 3.2.2, Calcasieu Parish has an effective date of designation for the 8-hour ozone standard of June 15, 2004, and a maintenance plan effective through 2014. After 2014, Calcasieu Parish would be expected to remain in compliance and there would be no obligation for an additional maintenance plan or conformity analysis. The plan effective through 2014 contains emission projections on a ton-per-day (tpd) basis for VOCs and NO_x. The plan presents an attainment emission inventory based on the year 2002, since 2002 is one of three years during which ambient monitoring demonstrated that ozone levels had attained the NAAQS. The LDEQ determined that these emission levels will maintain attainment of the ozone standard (LDEQ 2007). The emissions from the plan for the attainment demonstration year (2002) and the final plan year (2014) are shown in Table 4.2-8.

DOE evaluated the impact of construction of the LCCE Gasification plant and the Lake Charles CCS project in 2014, the final year of the LDEQ maintenance plan. Table 4.2-9 compares the construction emission estimates shown in Table 4.2-1 assuming an equal daily distribution of the annual emissions with the projected emission inventory for Calcasieu Parish for 2014. Total NO_x emissions would increase 1.9% and total VOC emissions would increase 0.5% above the projected 2014 values, as shown in Table 4.2-9. These increases in emissions from construction are negligible and would not obstruct maintaining attainment with the ozone standard.

Table 4.2-8 Calcasieu Parish Ozone Maintenance Plan Emission Budget (tons per day)

Source Type	2002		2014	
	NO _x	VOCs	NO _x	VOCs
Point	92.02	22.27	107.67	25.51
Non-Point	16.73	13.88	18.62	15.63
Non-Road Mobile	8.26	4.73	6.96	4.08
On-Road Mobile	16.34	8.71	5.69	3.71
Total (tons per day)	133.35	49.59	138.94	48.93

Source: LDEQ 2012.

Key:

NO_x = nitrogen oxides
VOCs = volatile organic compounds

Table 4.2-9 Comparison of 2014 Calcasieu Parish Ozone Maintenance Plan Emission Budget with LCCE Gasification and Lake Charles CSS Project Construction Emissions (tons per day)

Sources	Calcasieu Parish 2014		LCCE and Lake Charles CCS 2014		Percent Increase	
	NO _x	VOCs	NO _x	VOCs	NO _x	VOCs
Point	107.67	25.51	0.00	0.00	0.0%	0.0%
Non-Point	18.62	15.63	0.00	0.00	0.0%	0.0%
Non-Road Mobile	7.96	4.2	2.71	0.23	34.0%	5.6%
On-Road Mobile	5.69	3.71	0.00	0.00	0.0%	0.0%
Total (tpd)	139.94	49.05	2.71	0.23	1.9%	0.5%

4.2.5 Summary of Impacts

Tables 4.2-10 and 4.2-11 present summaries of the air quality impacts and minimization measures for the LCCE Gasification plant and the Lake Charles CCS project.

Table 4.2-10 Summary of Potential Impacts on Air Quality and Minimization Measures for LCCE Gasification Plant and Off-site Activities

Potential Impacts	Minimization Measure(s)
<p>Construction: Negligible Fugitive dust and vehicle and construction equipment emissions would be temporary and would not affect maintaining attainment with the ozone standard.</p>	<p>Leucadia would use BMPs including dust suppression techniques to control the dust generated by construction activities. Leucadia would operate and maintain construction equipment in accordance with manufacturers' recommendations and state regulations.</p>
<p>Operation: Negligible For all criteria pollutants, maximum modeled concentrations would not cause or contribute to any violation of the ambient air quality standards. The transport of petroleum coke would result in a reduction in emissions during shipment of 0.5 million tons per year of petroleum coke diverted.</p>	<p>Leucadia would operate the plant in accordance with the June 29, 2012, approved air permit and any subsequent modifications.</p>

Table 4.2-11 Summary of Potential Impacts on Air Quality and Minimization Measures for Lake Charles CCS Project

Potential Impacts	Minimization Measure(s)
<p>Construction and Operation of the CO₂ Capture and Compression Facilities: Negligible Included in the LCCE Gasification plant (see Table 4.2-10)</p>	<p>Included in the LCCE Gasification plant (see Table 4.2-10)</p>
<p>Construction of the CO₂ Pipeline or Alternative Pipeline: Negligible Fugitive dust and vehicle and construction equipment emissions would be temporary and have negligible impacts on air quality.</p>	<p>Denbury would implement BMPs including dust suppression techniques to minimize dust emissions during construction of the CO₂ pipeline.</p> <p>Denbury would operate and maintain construction equipment in accordance with manufacturers' recommendations and state regulations.</p>
<p>Operation of the CO₂ Pipeline or Alternative Pipeline: Negligible Vehicle emissions would be temporary and have negligible impacts on air quality.</p> <p>Fugitive emissions of CO₂ from the pipeline would be below applicable regulatory thresholds for permitting.</p>	<p>Denbury would operate and maintain vehicles in accordance with manufacturers' recommendations.</p>
<p>Operation of the West Hastings research MVA program: Negligible Fugitive dust and emissions from vehicles would have temporary, negligible impacts on air quality.</p>	<p>Denbury would operate and maintain vehicles in accordance with manufacturers' recommendations.</p>

4.3 Geology and Soils

4.3.1 Factors Considered for Assessing Impacts

DOE assessed the potential for impacts on geology based on whether the proposed project or connected action would directly or indirectly:

- result in local seismic destabilization (induced seismicity) and damage to structures;
- cause or be damaged by geologic-related events (e.g., earthquakes, landslides, mine subsidence, sinkholes);
- reduce the value of mineral resources or render them inaccessible;
- alter unique geologic features or landforms;
- result in the migration of CO₂ outside of the confining zone; or
- cause a measureable ground heave or upward vertical displacement of the ground surface resulting in impacts on structures or other surface or underground features.

DOE assessed the potential for impacts on physiography and soils based on whether the proposed project or connected action would directly or indirectly:

- temporarily or permanently disturb soils during the construction process;
- disturb soils with significant potential for surface erosion or on land surfaces with slopes in excess of 8 percent; or
- disturb soils listed as prime farmland or farmland of statewide importance.

The analysis of potential impacts also took into consideration design and operating practices that would be implemented to reduce erosion and soil disturbance, and whether any measures would be taken to avoid or minimize potential impacts on sensitive soils or soils listed as prime farmland or farmland of statewide importance. Potential impacts on soil from wastes and hazardous materials are discussed in Sections 4.12 (Waste Management) and 4.13 (Materials).

4.3.2 LCCE Gasification Plant (Connected Action)

4.3.2.1 Construction

4.3.2.1.1 Gasification Plant

Geology

Construction activities would include pile driving, which causes ground vibrations. Pilings would be driven approximately 40 to 50 feet into the ground or to sufficient depths in the ground to ensure that the buildings are adequately supported. No geologic hazards exist at the LLCE Gasification plant site that would impact the project or that would become more hazardous or be aggravated as a result of pile driving. The Gulf Coast, including the project area, is within Seismic Zone 0, the lowest seismic hazard category, according to the Uniform Building Code's Seismic Risk Map (ICBO 1997). The risk of a significant seismic event in this zone is minimal, and no activities during construction would result in seismic destabilization. Landslides or other slope failure impacts during construction or facility operations are considered unlikely due to the regional planar topography and absence of karst geology. Construction activities would not impact the value of mineral resources or render them inaccessible. Overall, construction would cause no or negligible impacts on geology.

Soils

With respect to soils, construction would involve grading the site, raising the site elevation with fill material, excavating for building foundations, compaction, creation of impermeable surfaces, and trenching to install necessary linear infrastructure. Soil disturbance and stockpiling could be subject to erosion from both wind and water. The site is underlain by silt loam soils. The identified soil types (Ac, BB, Kd, and Mt) are not susceptible to surface erosion and possess slopes well under 8 percent. As a result of these characteristics, construction activities would result in no or negligible impacts related to disturbance of soils with potential for surface erosion, or disturbance of soils on land surfaces with slopes in excess of 8 percent. Soil types Ac, Kd, and Mt meet the requirements for prime farmland. However, the site is in an industrial area of Calcasieu Parish; therefore, no impact on prime farmland would occur.

A National Pollution Discharge Elimination System (NPDES) General Permit for Storm Water Discharges from Construction Activities would be required for activities that result in a total land

disturbance equal to or greater than 1 acre and where discharges enter surface waters or a separate municipal storm sewer system. The purpose of the General Permit is to minimize discharges of pollutants in storm water discharges using control measures that reflect best engineering practices. In addition to using a SWPPP, dischargers must minimize pollutants in storm water by using appropriate erosion and sediment control BMPs and control measures for other pollutants such as litter, construction debris, and construction chemicals that could be exposed to storm water. Typical BMPs include the use of site access controls such as fencing, silt fencing, sediment barriers, and washdown areas to remove soil from vehicles before they exit the site. The SWPPP must (1) identify potential sources of pollution that may reasonably be expected to impact the quality of storm water discharges from the construction site, (2) describe the practices that would be implemented to reduce pollutants in storm water discharges associated with construction activities, and (3) describe the practices that would be used to retain sediment on-site to the maximum extent practicable.

Leucadia submitted a Notice of Intent (NOI) CSW-G and obtained a Storm Water General Permit Associated with Construction Activity from the LDEQ for the gasification site. Leucadia also prepared a site-specific SWPPP. Leucadia would use a combination of erosion and sediment control measures designed to prevent the mobilization of soil particles by construction and capture of those particles that do become mobilized and entrained in storm water. The erosion and sedimentation control plan developed for the LCCE Gasification site includes a storm water retention pond design to hold the 10-year, 24-hour storm. Leucadia would conduct construction activities in accordance with required federal and state permits and would implement BMPs stipulated in the permits, including silt fencing, sediment barriers, and washdown areas to remove soil from vehicles before they exit the site. As a result, construction of LCCE Gasification would cause no or negligible impacts on soil.

4.3.2.1.2 Off-Site Activities

Geology

The off-site activities identified on Figure 2.3-1 would occur within the Gulf Coast of Louisiana, where the risk of a seismic event is minimal (Seismic Zone 0). No off-site construction activities would result in seismic destabilization, and no geologic hazards exist that would impact the project or that would become more hazardous or be aggravated as a result of the off-site construction activities. Landslides or other slope failure impacts are considered unlikely due to the regional planar topography and absence of karst geology. No off-site activities would impact the value of mineral resources or render them inaccessible. In summary, construction of the off-site components of the LCCE Gasification plant would have negligible impacts on geology.

Soils

The parking area for construction workers would be located on an existing cleared and graded site in an industrial area. The site would be covered with gravel to minimize soil erosion from vehicle traffic and the use of the area for parking would be terminated after construction. Therefore, the impacts on soil in the construction parking area would be negligible and temporary.

The equipment laydown area would likely require grading prior to use and additional grading and excavating for shallow foundations, as it would be converted to the methanol and sulfuric acid tank storage area. Soils in the areas are not susceptible to surface erosion and possess slopes

well under 8 percent. Based on these characteristics, construction of the equipment laydown area would result in negligible impacts related to disturbance of soils on land surfaces with slopes in excess of 8 percent. Construction activities would disturb soil and have the potential to impact surface water through erosion from storm water runoff. Leucadia would obtain an NPDES General Permit for Storm Water Discharges from Construction Activities for preparation of the equipment laydown area and installation of the storage tanks. As described above, compliance with the permit and applicable regulations requires preparation of an SWPPP and the implementation of BMPs to minimize erosion and off-site transport of soils. Leucadia would conduct construction activities in accordance with required federal and state permits and implement mitigation measures stipulated in the permits such that construction of the equipment laydown and storage area would have negligible impacts on soil.

For natural gas, potable water, transmission, sulfuric acid, methanol, water supply, and hydrogen linears, construction activities with potential to impact soil include clearing and grading of the ROW, trenching, backfilling, and restoration for pipeline linears, and excavating for transmission line poles. Soils in the area are not susceptible to surface erosion and possess slopes well under 8 percent. Based on these characteristics, construction activities would result in negligible impacts related to disturbance of soils with potential for surface erosion, or disturbance of soils on land surfaces with slopes in excess of 8 percent.

Based on typical pipeline construction practices, DOE anticipates that more than 1 acre would be disturbed during construction of the required linears. Leucadia would submit a Notice of Intent (NOI) CSW-G to LDEQ to obtain an NPDES General Permit for Storm Water Discharges from Construction Activities prior to construction of the linears. As described above, compliance with the permit and applicable regulations requires preparation of a SWPPP and the implementation of BMPs to minimize erosion and off-site transport of soils. Leucadia would conduct activities in accordance with required federal and state permits and implement mitigation measures stipulated in the permits such that construction of the off-site linears would have negligible impacts on soil.

The proposed water supply and hydrogen pipeline routes pass through areas with soil types considered to be prime farmland, as shown on Figure 3.3-7 and in Table 4.3-1 below. Construction would progress along the route, and no location along the ROW would be disturbed for more than 3 months. In actively cultivated agricultural areas, Leucadia would contact landowners prior to construction to identify procedures for disturbance and restoration satisfactory to the affected landowners. Since the water supply and hydrogen pipelines would be located below the surface, impacts on prime farmland would be temporary and negligible, as surface conditions would be restored to their original condition and use.

Table 4.3-1 Prime Farmland Soil Designations in Water Supply and Hydrogen Pipeline Routes (95-foot-wide buffer)

Soil Type	Water Supply Route (acres)	Hydrogen Route (acres)
Ac	3.6	3.3
Gy	11.2	13.7
Kd	17.5	37.2
Lt		1.9
Mt		22.6
Total	32.3	78.8

4.3.2.2 Operation

Geology

As described previously, the project would be located within the Gulf Coast of Louisiana, where the risk of a seismic event is minimal (Seismic Zone 0). No operational activities would result in seismic destabilization, and no geologic hazards exist that would impact the project or that would become more hazardous or be aggravated as a result of operations. Landslides or other slope failure impacts are considered unlikely due to the regional planar topography and absence of karst geology. Operation would not impact the value of mineral resources or render them inaccessible. Operation of the LCCE Gasification plant would have negligible impacts on geology.

Soils

Operating activities would not disturb or expose soils. Areas not covered by impermeable surfaces would be landscaped and maintained. Pathways would be constructed to discourage foot traffic on unpaved areas, thereby protecting the remaining vegetation from disturbance and the soils from erosion. Minor spills or leaks from vehicles and material storage areas could impact soils. The proposed containment of fuel and chemical storage areas would minimize the potential for spills of fuel, oil, and chemicals to impact soils. The operation of the LCCE Gasification plant would have minor impacts on soils.

For natural gas, potable water, transmission, sulfuric acid, methanol, process water supply, and hydrogen pipelines, any areas of soil exposed during construction would be returned to their original condition and use. Minor spills or leaks from vehicles used during inspections and maintenance activities could impact soils. Proper maintenance of vehicles used for inspection and maintenance would minimize the potential for leaks. Overall, operation of the pipelines would have negligible impacts on surrounding soils.

Leucadia would submit a Notice of Intent (NOI) CSW-G and obtain a Storm Water General Permit Associated with Industrial Activity to the LDEQ. Leucadia would also prepare a site-specific SWPPP and conduct operation activities in accordance with required federal and state permits such that operation of the LCCE Gasification plant would have negligible impacts on soil.

4.3.3 Lake Charles CCS Project

4.3.3.1 CO₂ Capture and Compression Facilities

The CO₂ capture and compression facilities would occupy approximately 3.6 acres in the central portion of the approximately 70-acre LCCE Gasification plant site. Impacts on geology and soils from overall construction and operation of the LCCE Gasification plant include impacts from construction of the CO₂ capture and compression facilities.

4.3.3.2 CO₂ Pipeline

4.3.3.2.1 Proposed Route

Construction

The CO₂ pipeline would be constructed in the same manner as the raw water supply and hydrogen pipelines described above. No geologic hazards exist that would impact the pipeline construction or that would become more hazardous or be aggravated as a result of construction activities. The risk of seismic events is minimal because the area is within the lowest seismic hazard category (Zone 0) according to the Uniform Building Code's Seismic Risk Map (ICBO 1997). Because they are not coupled to the underlying crust and have historic low seismicity, faults along the Gulf Coast of Louisiana are generally unable to generate seismic ruptures sufficient to cause damaging ground motion (USGS 1998). No activities during construction would result in seismic destabilization. Landslides or other slope failure impacts during construction or facility operations are considered unlikely due to the regional planar topography and absence of karst geology. Pipeline construction would not impact the value of mineral resources or render them inaccessible. Overall, pipeline construction would have negligible impacts on geology.

Stockpiled and disturbed soils could be subject to erosion from both wind and water. Soil types present along the route are not susceptible to surface erosion and possess slopes that are well under 8 percent. Based on these characteristics, construction activities would have minor impacts on soils.

Denbury would submit a Notice of Intent (NOI) CSW-G to obtain an NPDES General Permit for Storm Water Discharges from Construction Activities. As described above, compliance with the permit and applicable regulations requires preparation of a SWPPP and the implementation of BMPs such as silt fencing, sediment barriers, and washdown areas to remove soil from vehicles before they exit the site to minimize erosion and off-site transport of soils. Denbury would conduct activities in accordance with required federal and state permits and implement mitigation measures stipulated in the permits such that construction of the CO₂ pipeline would have minor impacts on soil.

The proposed pipeline route passes through rural areas with soil types considered to be prime farmland, as shown on Figure 3.3-7 and in Table 4.3-2 below. Construction would progress along the route, and no location along the ROW would be disturbed for more than 3 months. In actively cultivated agricultural areas, Denbury would contact landowners prior to construction to identify irrigation pipelines or drain tiles within the construction ROW. Denbury would also develop irrigation crossing standards satisfactory to the affected landowners. Since the CO₂ pipeline would be located below the surface, impacts on prime farmland would be minor and temporary, as surface conditions would be restored to their original condition and use after construction.

Table 4.3-2 Prime Farmland Soil Designations in CO₂ Pipeline Route (95-foot-wide buffer)

Soil Type	Temporary Impacts (acres)
Ac	9.0
Gy	24.0
Kd	57.6
Lt	0.3
Mt	16.6
Total	107.4

Operation

Any areas of soil exposed during construction of the CO₂ pipeline would be returned to their original condition and usage. Minor spills or leaks from vehicles used during inspections and maintenance activities could impact soils. Proper maintenance of vehicles used for inspection and maintenance would minimize the potential for oil or fluid leaks. Potential leaks of CO₂ are discussed and modeled in Section 4.15. Overall, operation of the CO₂ pipeline would have negligible impacts on surrounding soils.

4.3.3.2 Alternative Route B

Construction

Alternative Route B is slightly shorter than the proposed route. Except for length, there are no significant differences in geology and soil characteristics between the two routes. Alternative Route B passes through rural areas with soil types considered to be prime farmland, as shown on Figure 3.3-7 and in Table 4.3-3 below. Rural and residential properties crossed by the pipeline would be addressed by Denbury in the same manner as previously described for the proposed route. As with the proposed pipeline route, there would be no impacts related to geology during construction of the pipeline along Alternative Route B. Measures to minimize soil erosion during construction of the pipeline along Alternative Route B would be the same as along the proposed pipeline route.

Table 4.3-3 Prime Farmland Soil Designations in Alternative B Route (95-foot-wide buffer)

Soil Type	Temporary Impacts (acres)
Gy	43.2
Kd	1.6
Lt	4.8
Mt	33.3
Total	82.9

Operation

Impacts and mitigation related to geology and soil during operation of the Alternative Route B pipeline would be the same as for the proposed pipeline route.

4.3.3.3 West Hastings Research MVA

During well reconversion activities, it is anticipated that workover rigs, ancillary equipment, and temporary facilities would be fabricated at and/or transported to each well location. At the

conclusion of the well conversion work, the equipment and temporary facilities would be removed, leaving only the existing access road and existing well pad around each injection wellhead (APCI 2011). Therefore, soil disturbance from well reconversion activities would generally be limited to previously disturbed soils within existing well pads. Existing access roads would be used to the extent practicable to access construction areas within the West Hastings oil field; therefore, soil impacts related to access roads would be negligible.

As part of the proposed project, Denbury would conduct research MVA activities at a portion of the West Hastings oil field to monitor the potential impacts of injection and sequestration of the injected CO₂ and to assess the effectiveness of EOR for long-term geologic storage of anthropogenic CO₂. The West Hastings research MVA activities would supplement privately funded, ongoing monitoring activities conducted in conjunction with Denbury's ongoing commercial EOR operations. As part of its commercial operations, Denbury currently reworks wells in the West Hastings oil field for injection of CO₂, production of oil and gas, testing, water production, and produced water disposal. The wells used for monitoring would be existing wells and accessed using existing roads.

As described in Table 2.3-2, the major components of the research MVA program at the West Hastings oil field include the following:

- **Well Integrity Testing.** The research MVA program would extend the existing commercial well integrity program at the West Hastings oil field by utilizing experimental logging tools to monitor potential CO₂ migration out of the targeted Frio storage reservoir. A range of groundwater and surface monitoring technologies would be used to monitor idle and P&A wells for potential evidence of upward migration of injected CO₂. Research MVA activities would include the use of augmented near-surface soil gas/aquifer surveillance methods and evaluation and use of data obtained at other soil gas testing projects to develop final soil gas monitoring strategies.
- **CO₂ Flood (Injection) Conformance Testing.** A combination of monitoring methods (e.g., geophysical, seismic, and gravity) would be used to gather additional data to assist in developing a model to simulate the movement and location of the injected CO₂.
- **Above-Zone Monitoring.** Approximately five wells would be reconditioned to measure the pressure in the deepest Miocene-age geologic reservoir to determine the extent of the pressure seal that exists. Above-zone monitoring interval (AZMI)-related research activities would include the use of high-temperature monitoring devices and pressure gauges to monitor the potential migration of CO₂.
- **Fault Monitoring.** Temperature and/or pressure data would be collected from wells that penetrate mapped faults in the West Hastings oil field sequestration area to evaluate whether CO₂ flow can be identified through the faults, and to confirm confinement of injected CO₂ flow within the Frio storage reservoir.

The proposed research MVA program for the West Hastings oil field is designed to provide a means to demonstrate and study CO₂ sequestration in a portion of the West Hastings oil field through existing EOR operations. The research activities included in the MVA program would supplement privately funded, ongoing monitoring activities conducted in conjunction with

Denbury's commercial EOR operations. Potential impacts on geologic resources related to this demonstration and study could result from the following:

- Seismic events or subsidence related to CO₂ injection;
- CO₂ migration through a permeable zone in the caprock;
- CO₂ migration through improperly plugged and abandoned wells or unknown wells; and
- CO₂ migration through an existing injection, production, or monitoring well.

However, DOE expects adverse impacts on geologic resources at the West Hastings oil field to be unlikely and negligible to minor due to the nature of the site and the activities being conducted. Injection of CO₂ into geologic formations produces thermal and pressure stresses with the potential to impact the physical and mechanical properties of geologic formations. The potential for impacts on geology and for the sequestration of CO₂ are related to whether these stresses result in seismic instability, alter geologic features, or result in the migration of CO₂ outside the confining zone. The West Hastings research MVA program would occur in a seismically stable area (Seismic Zone 0). None of the proposed West Hastings research MVA activities would produce vibrations or forces that would result in seismic destabilization, and no geologic hazards exist that would impact the project or that would become more hazardous or be aggravated as a result of the research MVA activities. Landslides or other slope failure impacts are considered unlikely due to the regional planar topography and absence of karst geology.

As discussed in Section 3.3.2, the regionally extensive Anahuac Formation, a thick, shale-rich unit, overlays the Frio Formation and has an average thickness of about 300 feet in the Brazoria County area (Swanson1 2009). This formation is sufficiently impermeable to confine and prevent the vertical migration of injected fluids (i.e., CO₂ and/or produced water) and displaced fluids. The Burkeville Confining System, which has a reported thickness of 300 to 500 feet (TDWR 1979), overlies the Anahuac Formation and is below the Chicot-Evangeline Aquifer. This confining system would further reduce the potential for any migrating injected or displaced fluids to reach overlying geologic units during or following EOR and/or produced-water disposal operations. Operations associated with the research MVA program would be temporary and would not result in permanent changes in geologic or soil conditions. In most cases, MVA activities would be conducted in or around existing idle or P&A wells owned by Denbury. The drilling of small-diameter, shallow subsurface (i.e., less than approximately 20 feet in depth) boreholes, and their subsequent use for soil-gas testing, would likely use small, temporary, truck-mounted equipment that would result in negligible impacts on soils over and above levels already observed as a result of ongoing commercial activities at the West Hastings oil field. The research activities undertaken as part of the MVA program associated with this project would not involve the removal or injection of any materials that would result in geologic subsidence (APCI 2011).

Leakage from one or more previously plugged and abandoned wells, oil-producing wells, injection wells, or observation wells might occur if any casing and/or cement placed in or around a well were to leak. To minimize the potential for impacts associated with casings or annular seals of wells in the proposed injection area, Denbury conducts well integrity testing prior to commercial EOR operations and corrects deficiencies prior to the use of such wells. These

improvements to existing wells would result in a beneficial impact on geological resources by reducing the chance of leakage due to improperly sealed wells.

All activities related to the commercial operations at the Hastings oil field would be permitted by the Texas RRC and implemented for the independent commercial EOR operations (Denbury 2011). The CO₂ injection wells would be operated in accordance with the Class II well permits issued by the RRC pursuant to the federal UIC of the Safe Drinking Water Act (SDWA). Class II well monitoring requirements, as well as Denbury's commercial practices, focus on injection pressure and volumes to avoid impacts on geology and the potential for migration of CO₂ to outside the confining zone. Denbury tests production wells at least twice per month to determine oil, water, and CO₂ production volumes; measures the CO₂ or water injected daily; and monitors tubing and casing pressures on all wells daily.

As indicated in Table 2.3-2, research MVA activities in the West Hastings oil field would include back-plugging of selected wells for above-zone monitoring, supplemental logging and testing of selected idle wells, drilling and testing of groundwater and soil-gas wells, and the performance of downhole seismic tests. Therefore, the proposed project may result in minor to negligible impacts on geologic resources. However, because CO₂ migration outside the target geologic units (i.e., within the Frio Formation) is unlikely, the potential for these types of impacts to occur due to the proposed research MVA activities is expected to be very low. Ongoing monitoring and modeling would provide an accurate accounting of approximately 1 million tpy of stored CO₂ and a high level of confidence that the CO₂ injected through the existing, commercial EOR process will remain sequestered permanently in a portion of the West Hastings oil field.

While operation of the proposed injection wells would necessarily alter conditions within the target geologic units, DOE expects overall impacts on these geologic resources to be negligible to minor. In addition, DOE expects the injection of CO₂ to beneficially impact the production of oil and gas from the Frio Formation sand units within the West Hastings oil field. More specifically, the use of CO₂ for EOR activities would be expected to induce the migration of additional hydrocarbon fluids present within the target geologic units (i.e., oil and gas that would otherwise be trapped in the formation) toward the oil production wells within the oil field, boosting oil production rates over those currently achieved. Furthermore, the presence of infrastructure for CO₂ floods may also make oil production from other geologic units at the field more feasible, resulting in an indirect beneficial impact on the value of these geologic resources.

4.3.4 Summary of Impacts

Tables 4.3-4 and 4.3-5 present summaries of the geology and soils impacts and minimization measures for the LCCE Gasification plant and the Lake Charles CCS project.

Table 4.3-4 Summary of Impacts on Geology and Soils and Minimization Measures for LCCE Gasification Plant and Off-site Activities

Potential Impacts	Minimization Measure(s)
<p>Construction: Negligible Soil disturbance and stockpiling could be subject to erosion from both wind and water.</p> <p>Approximately 32 acres and 79 acres of prime farmland would be temporarily affected by the water supply and hydrogen pipeline construction, respectively.</p>	<p>Leucadia would obtain a NPDES General Permit for Storm Water Discharges from Construction Activities, and would conduct construction and operation activities in accordance with required federal and state permits to minimize soil erosion.</p> <p>Leucadia would restore surface conditions to their original condition and use following pipeline construction.</p>
<p>Operation: Minor Minor spills or leaks from vehicles and material storage areas could impact soils.</p>	<p>Leucadia would implement BMPs and their SPCC plan, as necessary, during operation of the plant.</p>

Table 4.3-5 Summary of Potential Impacts on Geology and Soils and Minimization Measures for Lake Charles CCS Project

Potential Impacts	Minimization Measure(s)
<p>Construction and Operation of the CO₂ Capture and Compression Facilities: Negligible Included in the LCCE Gasification plant (see Table 4.3-4)</p>	<p>Included in the LCCE Gasification plant (see Table 4.3-4)</p>
<p>Construction of the CO₂ Pipeline or Alternative Pipeline: Minor Soil disturbance and stockpiling could be subject to erosion from both wind and water. Approximately 107 acres of prime farmland would be temporarily affected.</p>	<p>Any areas of soil exposed during construction of the CO₂ pipeline would be returned to their original condition and use.</p> <p>Denbury would obtain an NPDES General Permit for Storm Water Discharges from Construction Activities, and would conduct construction and operation activities in accordance with required federal and state permits and would implement mitigation measures stipulated in the permits such that soil erosion would be minor.</p>
<p>Operation of the CO₂ Pipeline or Alternative Pipeline: Negligible Any areas of soil exposed during construction of the CO₂ pipeline would be returned to their original condition and usage prior to operation.</p>	<p>No minimization measures would be necessary.</p>
<p>Operation of the West Hastings Research MVA program: Minor Approximately 4.6 million tons of CO₂ would be sequestered in a portion of the West Hastings oil field.</p>	<p>To minimize the potential for impacts related to casing or annular seal issues associated with wells in the proposed injection area, Denbury would conduct a well integrity testing program prior to EOR operations and would correct deficiencies prior to the use of such wells. CO₂ migration from the target geologic units is unlikely, but ongoing monitoring and modeling would provide an accurate accounting of approximately 1 million tpy of stored CO₂ and a high level of confidence that the CO₂ injected through the existing, commercial EOR process will remain sequestered permanently.</p>

4.4 Surface Water, Floodplains, and Wetlands

4.4.1 Factors Considered for Assessing Impacts

The DOE assessed the potential for impacts on surface water resources--which include wetlands and floodplains-- during the construction and operation of the Lake Charles CCS project and connected action. In addition, DOE evaluated the potential impacts of the proposed project and connected action in accordance with the Clean Water Act, as amended (33 U.S.C. §1251 et seq.); the Safe Drinking Water Act, as amended (42 U.S.C. § 300f et seq.); the Rivers and Harbors Act of 1899 (33 USC 403); 10 CFR 1022 (Compliance with Floodplain and Wetland Environmental Review Requirements); Executive Orders 11988 (Floodplain Management) and 11990 (Protection of Wetlands); and the applicable state and local regulations identified in Chapter 6.

EO 11988 requires federal agencies, while planning their actions, to avoid to the extent possible adverse impacts associated with the modification of floodplains and to avoid support of floodplain development when there is a practicable alternative. EO 11990 requires that federal agencies, while planning their actions, consider alternatives to affecting wetlands, if applicable, and limit adverse impacts to the extent practicable if they cannot be avoided. EO 11990 (Protection of Wetlands) and 11988 (Floodplain Management) require, among other things, that the DOE notify appropriate government agencies (e.g., the USACE for wetlands and FEMA for 100-year floodplains) and interested parties of a proposed action affecting wetlands; conduct a wetlands assessment to evaluate the impacts of that action on wetlands in an EA or EIS; consider alternatives that would avoid or minimize impacts on wetlands; design or modify the action to minimize potential impacts on wetlands; and allow for public review and comment of the analysis. Floodplains and wetlands impacts are summarized in Appendix E, Floodplains and Wetlands Assessment.

Factors considered for assessing impacts to surface water, floodplains, and wetlands were based on whether the proposed project or connected action would directly or indirectly:

- change surface water availability for current uses;
- degrade surface water quality by increasing erosion, increasing sedimentation, or introducing contaminants;
- violate any applicable federal, state, or regional water quality standards or discharge limitations;
- alter potential infiltration rates that could affect (substantially increase or decrease) the volume of surface water that flows downstream;
- conflict with applicable storm water or regional water quality management plans;
- increase the potential for floods;
- conflict with applicable flood management plans or ordinances;
- conflict with the Federal Emergency Management Agency's (FEMA's) national standard for floodplain management (i.e., maximum allowable increase of water surface elevation of 1 foot for a 1 percent annual chance [100-year recurrence interval] flood event); or

- fill wetlands or reduce the value of wetlands

Surface water impacts address impacts to surface water focusing on water quality and availability for use as a resource. Floodplain impacts were assessed for the placement of fill material or structures in a floodplain in a manner that would expose people or structures to increased levels of flood hazards or fail to comply with FEMA's national standard for floodplain management. For wetland impacts, three types of potential impacts could occur:

1. Direct wetland loss by placement of fill material and/or structures (fill material is defined by the applicable regulatory agencies [USACE and EPA] as "*...in both the Corps' and EPA's regulations as material placed in waters of the U.S. where the material has the effect of either replacing any portion of a water of the United States with dry land or changing the bottom elevation of any portion of a water.*" [Federal Register, Volume 67, Number 90])
2. Wetland type conversions where project activities would cause changes to the vegetation community of the wetland, i.e. convert forested wetland to emergent wetland.
3. Temporary wetland disturbances, which are considered temporary due to construction-related activities that are followed by restoration.

DOE utilized field surveys conducted in 2007 by the Port of Lake Charles and a jurisdictional wetland determination conducted by the USACE New Orleans District as part of a 2008 USACE permit approval for LCCE Gasification site development, conducted in 2011 along the proposed and alternative pipeline routes, and a desk top survey of USFW NWI mapping of the Hastings oil field site to locate and delineate wetlands in areas that would be affected by the project or connected action. DOE assessed impacts to wetlands and floodplains primarily by using GIS to calculate impact acreages for reported wetlands and mapped floodplains and also relied on flood hazard analysis undertaken in 2012 by the Calcasieu Parish Police Jury Engineering Department. Baseline environmental data (i.e., wetlands and floodplains locations) were overlaid with project features to determine the locations and areal extents of potential wetland and floodplain impacts.

4.4.2 LCCE Gasification (Connected Action)

4.4.2.1 Construction

4.4.2.1.1 Gasification Plant

Surface Water

Leucadia would purchase water for the LCCE Gasification plant construction from the City of Sulphur for dust control, concrete mixing, sanitary uses, cleaning, hydrostatic testing of pipes, and fire protection. During the 3-year construction period, Leucadia would use approximately 6,000 gallons of water per day. The City of Sulphur obtains its potable water from the Chicot Aquifer. The City shares use of the Chicot aquifer with other cities and water supply corporations. The City's water plants produce between 3 and 7 million gallons per day (Sulphur 2012a). The water volumes used during construction would be less than 1 percent of the daily current available supply from the City of Sulphur. Therefore, the 3-year construction period would not decrease the water supply in the area. No significant decrease in the local availability of water would occur as a result of construction of the LCCE Gasification plant.

Construction activities have the potential to introduce contaminants to storm water runoff through excavation, material delivery and storage, concrete washout, waste generation, and equipment and vehicle use and storage. As storm water runoff moves across the site surfaces, it picks up sediment particles or soil, but also collects oil and grease, and residue from materials used on the site as well as fuels, grease, and lubricants incidentally leaked from vehicles and equipment or accidentally spilled. Storm water from the site would discharge directly to the Calcasieu River Ship Channel via existing outfalls. Leucadia submitted an NOI for a NPDES General Permit for Storm Water Discharges From Construction Activities to LDEQ and prepared a SWPPP. The General Permit and the Calcasieu Parish Police Jury Code of Ordinances, Division 4 - Storm Water Discharges from Construction Activities require that storm water discharges not exceed specified TMDL levels in current water quality standards. The SWPPP must include a description of all pollution control measures, or BMPs, that would control erosion, sedimentation, and pollutants in storm water discharges. The SWPPP must describe measures to minimize, to the extent practicable, the tracking of sediments off-site by vehicle onto paved surfaces, the generation of dust, and the proper maintenance of vehicles and equipment during construction to reduce the risk of spills and accidental exposure and to protect water quality. The SWPPP must include descriptions of construction and waste materials expected to be stored on-site, including a description of controls and practices to minimize exposure of the materials to storm water, and spill prevention and response practices. Leucadia would conduct activities in accordance with required federal and state permits and would comply with the water quality standards and discharge limitations stipulated in the permits such that surface water impacts from storm water runoff would be minor and would not degrade surface water quality by increasing erosion or sedimentation, or by introducing contaminants.

Construction of the LCCE Gasification plant would not alter the navigability of the Calcasieu River. However, because the LCCE Gasification plant is located along the Calcasieu Ship Channel, a federally maintained channel, any activity within the channel may need to undergo Coast Guard review. During the final design process, a description and map of the facility, including a letter of intent, would be sent to the Coast Guard for approval and clearance.

Floodplains

In compliance with the Executive Order 11988 (Floodplain Management), DOE evaluated whether the LCCE Gasification plant construction conflicts with applicable local flood management plans or ordinances, or with FEMA's national standard for floodplain management. As described in in Section 3.4.3.1, prior to development by Leucadia, USACE issued a permit to construct to the Port of Lake Charles for the Lake Charles Cogeneration project. The permit process includes analysis of the foreseeable impacts the proposed work would have on many factors, including navigation, general environmental concerns, wetlands, economics, fish and wildlife values, land use, floodplain values, and the needs and welfare of the people. The application requirements include a project description with supporting engineering drawings and documents that clearly and accurately document the location and footprint of facility components and any impacts to the Waters of the US, including floodplains, due to construction and/or operation of a project. Subsequently, Lake Charles Clean Energy, LLC received a waiver from undertaking a drainage impact analysis based on documentation submitted to the Calcasieu Parish Police Jury Division of Engineering and Public Works (Conner 2012). Therefore, construction of the site would not conflict with applicable flood management plans or ordinances and would not increase the potential for floods. The 70-acre site is negligible compared to the

2,240,000 acre watershed area of the Calcasieu River, and the increase in the volume of site runoff would not significantly increase flow volumes downstream.

Wetlands

As described in 3.4.3.1, prior to development by Leucadia, the site contained 26.2 acres cypress-tupelo and emergent freshwater marsh, along with 2,200 linear feet of riverine shoreline (URS 2010). Based on the wetland delineation and USACE jurisdictional determination, the Port of Lake Charles received a permit August 18, 2008 to construct a facility on the 70-acre site. Site preparation activities for the LCCE Gasification Plant including clearing and grading commenced in January 2010. Wetland impacts were addressed through off-site mitigation banking of 26.2 acres of wetlands through an agreement between the Port of Lake Charles and Stream Wetland Services, LLC. A total of 116,791 acres of wetlands in the Calcasieu-Sabine Basin has converted to open water since 1932 (USGS, 2007). The Calcasieu sub-basin lost 37,238 acres of land between 1933 and 1990, with an average annual acreage loss of 0.5 percent (LCWCRTF 1993). The wetlands filled as a result of the LCCE Gasification construction is less than 1 percent of the wetlands remaining in either the Bayou D'Inde watershed or the larger Calcasieu sub-basin watershed.

4.4.2.1.2 Off-Site Activities

Surface Water

Water required for construction of the parking area would include one water truck supplying an average of 2,000 gallon per day, for 3 years. This water would be purchased from the City of Sulphur. This is a negligible volume of water and would not affect local water availability compared to available capacity of 3 to 7 million gallons per day. Vehicle traffic to and from the construction parking area would have the potential to create short-term, direct impacts on surface water quality through erosion and equipment drips and leaks that would be entrained in storm water runoff. Given the average monthly precipitation of 3 to 6 inches, runoff generated monthly ranges from 54,450 cubic feet (408,375 gallons) to 108,900 cubic feet (816,750 gallons). Land cover change has been shown to increase runoff and downstream peak flows. The gravel surfacing of the parking area underlain with compacted soils would allow approximately 50% infiltration of storm water to continue and reduce runoff compared to an impervious surface which discharges 100% runoff. Permeable parking surfaces have been shown to reduce pollutant concentrations in runoff as compared to impervious asphalt parking areas (Balades 1995; EPA 1999).

The location of a 40-acre off-site area that would be used for equipment laydown during construction and methanol/sulfuric acid storage during operation has not been finalized. It is projected that this area would be located within approximately 1 mile of the LCCE Gasification plant site. Because the proposed project site is adjacent to the Calcasieu River, proximate to the Bayou D'Inde, and within the upper reaches of the Calcasieu River Estuary, the laydown and storage area that is selected may contain wetlands. Leucadia would perform a survey of the site to identify wetlands and protected habitat to determine whether adverse impacts on wetlands could be avoided or minimized. Leucadia's site selection criteria include avoiding locations with wetlands. Leucadia would coordinate with the local floodplain administrator to avoid any likelihood of impacts on local flooding. The USACE regulates the discharge of dredged, excavated, or fill material into U.S. waters (e.g. rivers, streams, bayous, and wetlands), and the placement of structures in navigable waters such as may result from construction of the

equipment laydown area and methanol/sulfuric acid storage area. Requirements under the applicable regulations include identifying waters of the U.S., including wetlands; assessing the potential impacts on waters of the U.S.; modifying plans to first avoid impacts, then minimize impacts, or finally, to fully mitigate for unavoidable impacts. The regulations also require obtaining authorization through preconstruction notification, a Nationwide Permit, or an Individual Permit, depending on the level of impact. If a water body is determined to be a water of the U.S. (jurisdictional) and the construction impacts on wetlands exceed the applicable thresholds, Leucadia would obtain the necessary USACE permit. If applicable, the USACE permit would address whether mitigation for wetlands impacts would be required.

Storm water runoff generated monthly on average from a 40-acre site could be between 435,600 cubic feet (3.2 million gallons) to 871,200 cubic feet (6.5 million gallons). Construction of the methanol and sulfuric acid tank storage area would likely require grading, filling, and excavating for shallow foundations. Preparation of the equipment laydown area would involve clearing and grading, which have the potential to cause soil erosion and impact surface water quality from storm water runoff carrying sediment or soil, but also collecting oil and grease from vehicles and equipment or material storage areas, and residue from materials used on the site.

The natural gas, potable water, transmission linears shown on Figure 2.3-1 would be collocated within existing utility ROWs on the east side of Bayou D'Inde Road. Although the routes of the methanol and sulfuric acid pipelines are not finalized, the same types of surface water impacts would occur as for other linears. Construction activities with potential to impact surface water through storm water runoff include clearing and grading of the ROW, trenching, backfilling, and restoration for pipelines and excavations for transmission line poles, which have the potential to cause soil erosion and impact surface water quality from storm water runoff carrying sediment or soil, but also collecting oil and grease from vehicles and equipment. The potential alternative route for the transmission line on the west side of Louisiana Pigment is within an open corridor in an existing industrial area that would be cleared and graded for the CO₂ pipeline.

Construction of the water supply and hydrogen pipeline would include site clearing, grading, trenching, backfilling, and restoration activities. The raw water and hydrogen pipelines would cross the surface waters as shown in Tables 4.4-1 and 4.4-2, respectively.

Table 4.4-1 Surface Water Crossings of the Water Supply Pipeline

Description	Type	Length (feet)
Bayou D'Inde	HDD	3500
Bayou Verdine	Span	100

Table 4.4-2 Surface Water Crossings of the Hydrogen Pipeline

Description	Type	Length (feet)
Unnamed Tributary 1	Wet/Dry	250
Unnamed Tributary 2	Wet/Dry	250
Sabine River Canal	HDD	350
Bayou D'Inde	HDD	350
Drainage Ditch- Near Carbide Drive	Wet/Dry	100
Bayou D'Inde Tributary	HDD	550

Pipeline crossings of surface waters avoid or minimize potential impacts through various crossing methods. A field assessment would be made prior to construction at each crossing to determine the presence of water as well as determine the velocity and sensitivity of the surface water at the time of construction which in turn would determine the trenching method to be employed (e.g., wet or dry trenching). A wet crossing would typically apply to small perennial streams, field and roadside ditches, and intermittent or ephemeral streams. The stream should be small enough to enable the equipment to be worked from the banks. A backhoe would open a temporary trench within the flowing stream; the pipe would be placed and the trench backfilled as quickly as possible to minimize impacts. A wet crossing would also typically be used in surface waters greater than 50 feet wide. A pipeline trench would be opened within the flowing stream using a backhoe or dragline, and the pipe would be pulled or floated into place. Flow in these streams would most likely be sufficient to inundate the trench and allow for a natural downstream flow to continue. Sufficient downstream flow should be maintained during construction. Following installation of the pipe, the trench would be backfilled and stream bottom restored. A dry crossing would typically apply to surface waters less than 30 feet wide, including perennial streams (with flow) less than 30 feet in width with downstream water users or with listed species present in the stream. Stream flow may be channeled into one or multiple flume pipes to convey water across the trench and maintain downstream flow, or alternatively, a dam-and-pump arrangement may be used to temporarily convey the stream water around the construction area. The trench would be excavated from under the flume pipe, the pipeline would be threaded under the flume, the trench would be backfilled, and the flume pipe would be removed to restore natural downstream flow. The horizontal directional drilling (HDD) method of crossing would apply to specially designated stream crossings, such as crossing Bayou D'Inde. Figure 4.4-1 illustrates a typical HDD construction method. The HDD method involves using specialized equipment to install pipelines beneath the surface water, i.e. wetlands or waterways, which potentially minimizes environmental impacts. However, a potential exists for environmental impacts, such as turbidity and deposition of drilling muds, which can accidentally occur from the inadvertent back up of drilling muds during the drilling process. These potential impacts are reported immediately and cleaned up typically with full restoration as part of an HDD failure contingency plan and/or drilling mud disposal plan. The applicability of this method is subject to a variety of site-specific physical and engineering factors and specified in the actual permit to be obtained for pipeline installation. Therefore, this method is applicable to water bodies with conditions determined to be suitable and after extensive assessment and permitting for both environmental and engineering considerations.

Leucadia proposes to cross specially designated perennial waterbodies, including wetlands, using the HDD method; and to cross other surface waters using wet and dry crossing as described above, with conventional pipeline crossing techniques, potentially including both wet and dry trenching methods, which include full restoration of a site after construction. Potential surface

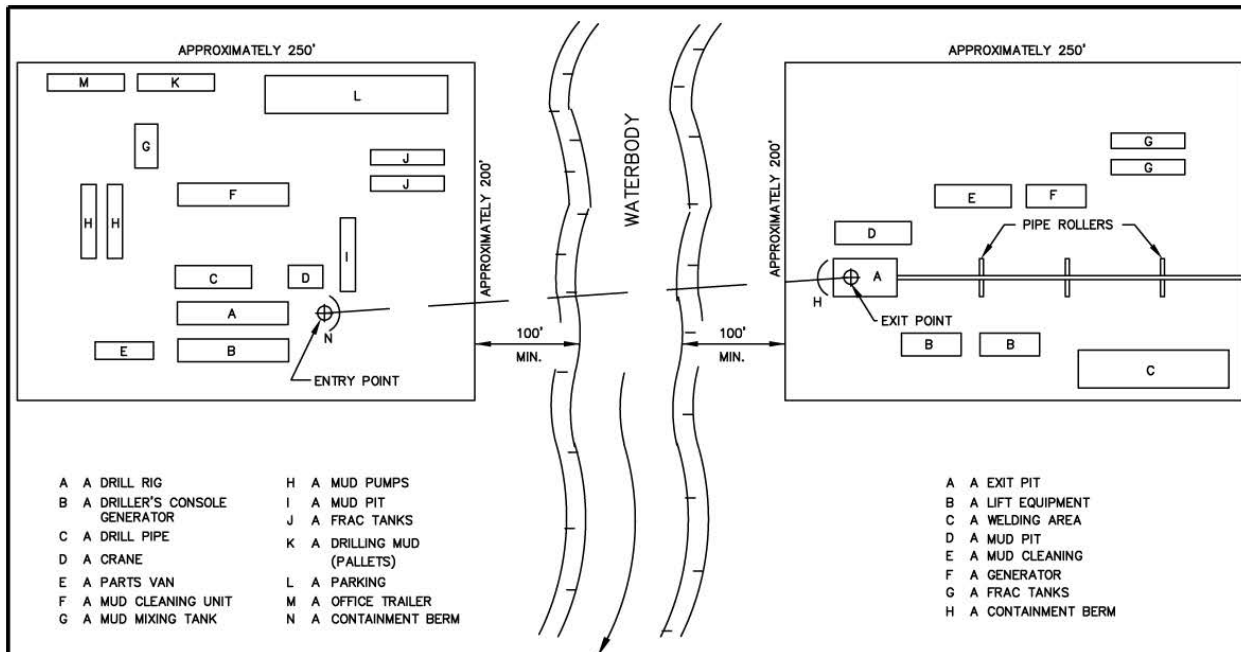

- | | | |
|---------------------------------|-----------------------------|----------------------|
| A A DRILL RIG | H A MUD PUMPS | A A EXIT PIT |
| B A DRILLER'S CONSOLE GENERATOR | I A MUD PIT | B A LIFT EQUIPMENT |
| C A DRILL PIPE | J A FRAC TANKS | C A WELDING AREA |
| D A CRANE | K A DRILLING MUD (PALLETES) | D A MUD PIT |
| E A PARTS VAN | L A PARKING | E A MUD CLEANING |
| F A MUD CLEANING UNIT | M A OFFICE TRAILER | F A GENERATOR |
| G A MUD MIXING TANK | N A CONTAINMENT BERM | G A FRAC TANKS |
| | | H A CONTAINMENT BERM |

PLAN

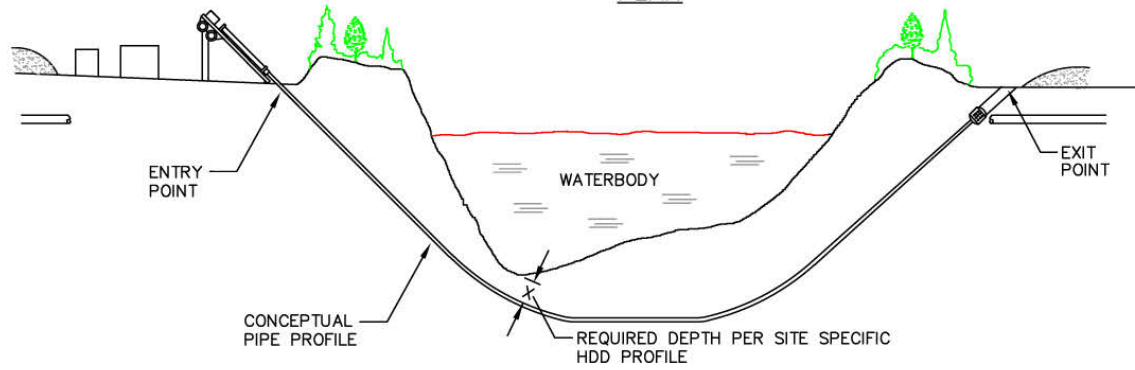

PROFILE

NOTES:

1. SET UP DRILLING EQUIPMENT A MINIMUM OF 100 FEET FROM THE EDGE OF THE WATERBODY. DO NOT CLEAR OR GRADE WITHIN THE 100 FOOT ZONE.
2. ENSURE THAT ONLY BENTONITE BASED DRILLING MUD IS USED. DO NOT ALLOW THE USE OF ANY ADDITIVES TO THE DRILLING MUD WITHOUT THE APPROVAL OF COMPANY'S INSPECTOR.
3. INSTALL SUITABLE DRILLING MUD TANKS OR SUMPS TO PREVENT CONTAMINATION OF WATERBODY.
4. INSTALL BERMS DOWNSLOPE FROM THE DRILL ENTRY AND ANTICIPATED EXIT POINTS TO CONTAIN ANY RELEASE OF DRILLING MUD.
5. DISPOSE OF DRILLING MUD IN ACCORDANCE WITH THE APPROPRIATE REGULATORY AUTHORITY REQUIREMENTS.

REVISIONS						NO.	DESCRIPTION	DATE	BY	CHK.	APPR.
0	ISSUE FOR USE	5-18-2012									

DRAWN BY:	
CHECKED BY:	
REVIEWED BY:	
APPROVED BY:	
PROJECT MANAGER:	

<p>Figure 4.4-1 Horizontal Direction Drilling Waterbody Crossing, Typical Construction</p>		PROJECT NUMBER	DRAWING NUMBER	REV.
SCALE: NONE			TYP-015	0

water impacts that could result from construction of pipeline crossings using trenching methods include temporary stream diversion/piping flows around the crossing, increased localized turbidity and sedimentation during streambed disturbance, and the removal of stream bank vegetation. Temporary impacts could extend downstream, depending on flow and mixing conditions. Pipeline installation can also result in temporary erosion and sedimentation, and accidental spills of lubricants and/or chemicals. The accidental release of fuels, lubricants, and coolants used by heavy equipment during pipeline installation could cause an impact to water quality. Leucadia would design an SPCC plan to minimize the potential for impacts to surface waters during construction. Access roads would be required for pipeline installation. Where practicable, previously existing access roads would be used during construction and returned to original or better condition upon completion of the pipeline installation. New access roads constructed specifically for the pipeline installation would be removed, the surface graded to original contours, and the land restored to its original condition and use, unless otherwise requested by the landowner or unless the roads would be required for ongoing maintenance access to the ROW during pipeline operations. Temporary erosion-control measures would be removed upon final stabilization and installation of permanent erosion-control measures.

Prior to being placed in service, all components in the high-pressure pipeline systems require hydrostatic testing to USDOT standards in 49 C.F.R. Part 192. Pipeline segments and newly completed pipelines are hydrostatically tested with clean water. Leucadia would purchase water from Bayou D'Inde, the Sabine Canal, and municipal sources for hydrostatic testing of pipes. Test water is recycled during the pipeline installation/testing process and ultimately discharged to a permitted discharge point which is generally not waters of the U.S., including wetlands. The test water is generally discharged within the construction ROW through an energy-dissipating device and otherwise managed in compliance with applicable NPDES permit conditions. The hydrostatic test water would be discharged only after analytical testing results demonstrate that the hydrostatic test water meets discharge requirements. Hydrostatic testing of the water supply and hydrogen pipelines would require approximately 193,600 and 412,890 gallons, respectively.

Leucadia would conduct activities in accordance with the required Hydrostatic Test Discharge Permit and would implement mitigation measures stipulated in the permit such that impacts on surface water availability and surface water quality would be temporary and negligible.

Based on typical pipeline construction practices, DOE anticipates that more than 1 acre would be disturbed during construction of the required linears.. Leucadia would submit a Notice of Intent (NOI) CSW-G to LDEQ to obtain an NPDES General Permit for Storm Water Discharges from Construction Activities prior to construction of the linears. The SWPPP and BMPs, described in 4.4.1.2.2, control surface and subsurface slope drainage, minimize slope erosion, and minimize or prevent channel erosion at stream crossings. Leucadia would perform construction in accordance with required federal and state permits and implement BMPs specified in the SWPPP to avoid erosion and sedimentation such that surface water impacts would be temporary and minor.

Floodplains

The proposed construction parking area is located within the 100-year floodplain of the Calcasieu River. However, any filling would consist of approximately 4 to 6 inches of gravel for a level firm surface and would not raise elevation within the floodplain, cause impacts to increase the potential for floods, conflict with applicable flood management plans or ordinances,

nor conflict with the Federal Emergency Management Agency's (FEMA's) national standard for floodplain management. Therefore, negligible impacts to the floodplain would occur as a result of the construction parking area.

Construction of the equipment laydown area could potentially impact 40 acres of 100-year floodplain of Bayou D'Inde and/or Calcasieu River. DOE assumed 100% floodplain coverage to assess the maximum disturbance, since the site has not been selected. Leucadia anticipates that the site would be filled or elevated above the floodplain which would divert flood waters. However, flood waters are conveyed in this vicinity through the designated floodway of the Calcasieu Ship Channel and River which drains the 2.24 million-acre Calcasieu watershed. This designated floodway below the project site extends 8 miles along the ship channel and encompasses 3,976 acres from Coon Island to the outflow of Moss Lake, includes Lake Prien, Moss Lake, the Calcasieu Ship Canal, and the old channel of the Calcasieu River. Once the site is selected, the USACE would require permits for construction that would ensure there is no conflict with applicable local flood management plans or ordinances or FEMA national standard for floodplain management.

The proposed natural gas, potable water, sulfuric acid, and methanol linears would be installed below ground within the 100-year floodplain of Bayou D'Inde and Calcasieu River. Because natural gas and potable water lines would be installed below grade, no floodplain filling would occur. The transmission line pole footings would also be below grade and would have no effect on the floodplain. There would be no measurable infiltration rates that could increase downstream volumes as a result of installation when compared to the drainage already being handled from the 2.24 million acres of the Calcasieu watershed.

The water supply and hydrogen pipelines would be installed below ground within the 100-year floodplain of Bayou D'Inde and Calcasieu River. Given the 95 foot permanent pipeline ROW and the temporary construction ROW, no measurable alteration of infiltration rates would be expected to occur. Therefore, no substantial decrease in the volume of surface water that flows downstream would result. Because the pipelines would be buried, fill above the existing ground elevations would not occur and there would be no permanent effect on surface storm water flow patterns or flooding and/or conflict with applicable local storm water management plans. Pipeline construction permitted under the USACE permit and local building permits would not alter a floodway or floodplain or otherwise impede or redirect flows in a manner that would increase the potential for floods or impacts on human health, the environment, or personal property, nor would construction conflict with applicable local flood management plans or parish ordinances. Therefore, the permitted pipeline would not impact the floodplain or conflict with FEMA's national standard for floodplain management.

Wetlands

No wetlands are present within the location proposed for the off-site construction parking area. An open water feature is present immediately west of the proposed location and is a man-made borrow pit for sand and would be classified as a non-jurisdictional open water pond. Local drainage patterns and site grading should direct any runoff from the parking area and not result in direct impacts to this open water feature. A potential wetland is present approximately 700 feet southeast of the proposed parking area. However, the parking area is physically separated from this potential wetland by LA 108. Therefore no impacts to wetlands would occur from the

construction parking area. There are no wetlands present within the locations proposed for the off-site natural gas, potable water, transmission, sulfuric acid, and methanol linears.

Construction of the equipment laydown area could potentially result in the filling of up to 40 acres of wetlands. DOE assumed 100% wetland coverage to assess the maximum disturbance, since the site has not been selected. If avoidance is not practicable, the USACE would require permits for filling and mitigation to offset the filling or reduction in value of wetlands. The Bayou D’Inde watershed is approximately 8,640 acres in size and has approximately 2,583 acres of forest remaining, of which approximately half is forested wetland. Calcasieu River watershed below the site is approximately 706,752 acres and a majority of it is open water and wetlands, particularly south of Moss Lake. A total of 116,791 acres of wetlands in the Calcasieu-Sabine Basin have converted to open water since 1932 (USGS 2007). A loss of 40 acres of wetlands within the Bayou D’Inde watershed would represent less than 3 percent of the wetlands present within the watershed. In addition, the USACE would require compliance with the “no net loss” policy through replacement of wetlands to offset the loss from the proposed construction. Therefore, minor impacts on wetlands would be expected.

For the water supply and hydrogen pipeline routes, a desktop review identified potential wetlands using the U.S. Fish and Wildlife Service’s National Wetlands Inventory (NWI) maps, the U.S. Department of Agriculture’ Soil Survey of Calcasieu Parish for indications of wetlands (hydric) soils, and regional aerial photographs. Tables 4.4-3 and 4.4-4 summarize the potential wetland impacts that may result from construction of the raw water supply and hydrogen pipelines. The estimate of wetland impacts assumes the use of an open-lay construction method; however, in some cases, HDD would be used for construction, and wetland impacts would be reduced or avoided.

Table 4.4-3 Potential Wetland Impacts by Segments for the Water Supply Pipeline

Segment	Length (feet)	Square Feet	Acres
2	5	500	0.01
7	45	4,500	0.1
8	1,500	150,000	3.44
Total			3.55

Source: URS 2012.

Note: The potential impact estimate is based on the use of an open-lay construction method and is a worst-case estimate.

Table 4.4-4 Potential Wetland Impacts by Segment for the Hydrogen Pipeline

Segment	Length (feet)	Square Feet	Acres
4	25	2,500	0.06
6	15	1,500	0.07
8	36	3,600	0.08
10	85	8,500	0.08
12	770	77,000	1.8
16	650	65,000	1.5
Total			3.59

Source: URS, 2012

Note: The potential impact estimate is based on the use of an open-lay construction method and is a worst-case estimate.

As described in Section 2.3.1, Leucadia selected the route for the water supply and hydrogen pipeline routes using siting criteria including use of existing utility corridors, avoidance of wetlands, streams and floodplains, and minimizing the number of pipeline and linear stream crossings. For the wetland impacts that cannot be avoided, the USACE regulates, under Sections 9 and 10 of the Rivers and Harbors Act and Section 404 of the Clean Water Act, discharges of dredged, excavated, or fill material into U.S. waters (rivers, streams, and bayous), including associated wetlands, and the placement of structures in navigable waters such as that associated with construction of pipelines. Requirements under the applicable regulations include identifying waters of the U.S., including wetlands; assessing the potential impacts on waters of the U.S.; and modifying plans to first avoid impacts, then minimize impacts, or finally, to fully mitigate for unavoidable impacts. The regulations also require obtaining permits, either through preconstruction notification, a Nationwide Permit, or an Individual Permit, depending on the level of impact. For segments of the pipelines with the potential to impact wetlands, a site-specific survey would be required to quantify any potential wetland impacts.

If a water body crossed by the pipeline is determined to be a water of the U.S. (jurisdictional) and the construction impacts on wetlands exceed the applicable thresholds, Leucadia would obtain the necessary USACE Permits and perform construction in accordance with required federal and state permits. Leucadia would comply with standards or mitigations stipulated in the permits such that impacts on wetlands would be minor. Alternatively, Leucadia could implement HDD construction methods and avoid wetland impacts, and no mitigation would be necessary. Minor impacts on wetlands from construction of the water supply and hydrogen pipelines would be expected.

4.4.2.2 Operation

4.4.2.2.1 Gasification Plant

Surface Water

The City of Sulphur will upgrade an existing potable water pipeline to supply approximately 3,000 gallons per day to the LCCE Gasification plant. Leucadia contracted with the Sabine River Authority (SRA) to purchase an annual average maximum of 8,500 GPM, or 12.2 million gallons per day of raw water from Sabine River. The Toledo Bend Reservoir, an area of 185,000 acres with a controlled storage capacity of 4,477,000 acre-feet, or 1,448 million gallons, feeds the Sabine River Diversion Canal (SRA 2013). Because this large volume of water is available from the reservoir and the purpose of the canal is to supply water to industries, the LCCE Gasification plant's withdrawal would be expected to have no or negligible impact on water availability and local water use.

The treated waste water discharges from the LCCE Gasification plant consists of non-contact cooling water blowdown, water treatment reject and regeneration water, and water from oil/water separators (plant and equipment drains). Wastewater discharges would be directed to either Outfall 001 or Outfall 002 as directed by the LDEQ LPDES Water Discharge Permit LA0124541 and AI No. 160213. Wastewater discharge limits are summarized in Table 4.4-5.

Table 4.4-5 Effluent Limitations for the LCCE Gasification Plant for Outfall 001 and 002

Parameter	Daily Max (mg/L)		Monthly Average (mg/L)	
	001	002	001	002
Flow	Monthly Estimate	Monthly Estimate	NA	2,500
Oil & Grease	15	20	NA	1,500
Total Organic Carbon	50	50	NA	3,600
Total Suspended Solids	NA	100	NA	30
pH	9	9	6	6
Total Mercury	Report only	Report only	NA	77,000
Total Copper	Report only	Report only	NA	65,000
Floating Solids or Visible Foam	Trace	Trace	Trace	Trace
Material Toxic to Aquatic Organisms	None	None	None	None
Total				

Source: LPDES Permit LA0124541

Key:
NA = Not Applicable

Material handling and storage areas, parking areas, rooftops, and access roads would be exposed to storm water. Storm water exposed to these areas could contain pollutants. The site design incorporates confinement levees and treatment features to minimize the potential for contamination of surface storm water. The storm water collection system would be designed to capture a 100-year storm event. The storm water discharges would include non-process area storm water, post-first-flush storm water from process areas, non-contact (uncontaminated) area storm water, and secondary containment area storm water. Secondary containment areas would be located throughout the site to isolate spills and any contaminated runoff. Rainwater collected from containment areas would be directed to oil/water separators before discharge. Any storm water runoff would discharge via existing permitted outfalls to the Calcasieu Ship Channel.

Leucadia would obtain an NPDES General Permit for Storm Water Discharges from Industrial Activities during operation. The Application for an LPDES permit provides information necessary for LDEQ to develop LPDES permit effluent limitations based on technical evaluations of promulgated effluent guidelines, existing effluent quality, receiving water conditions, and waste load allocations to meet Louisiana water quality standards.

Leucadia would conduct activities in accordance with required federal and state permits and would comply with water quality standards and discharge limitations stipulated in the permits such that surface water impacts from storm water runoff would be minor and would not degrade surface water quality by increasing erosion or sedimentation, or by introducing contaminants.

Floodplains and Wetlands

Operation would not increase the potential for floods; alter a floodway or floodplain or otherwise impede or redirect flows such that human health, the environment, or personal property could be affected; nor conflict with applicable local or FEMA flood management plans or ordinances. Therefore, no floodplain impacts would be anticipated as a result of operations. Operations would not result in any additional wetland fills.

4.4.2.2.2 Off-Site Activities

Once construction is completed, Leucadia would terminate use of the construction parking area. Therefore, no impacts on surface water, floodplains, or wetlands would occur.

Surface Water

Material handling and storage activities, such as loading of trucks from the storage tanks, would be exposed to storms and flooding events. Storm water exposed to these activities could contain soil or pollutants. If required, Leucadia would obtain an NPDES General Permit for Storm Water Discharges from Industrial Activities during operation. Leucadia would operate in accordance with required federal and state permits and implement BMPs specified in the SWPPP to limit exposing storm water to pollutants such that surface water quality impacts would be minor. There is the potential for surface water contamination to occur during maintenance activities should an accidental spill occur, however, the implementation of BMPs and an SPCC plan would reduce or avoid possible impacts. The potential risk of an accidental spill from material handling and storage during operation is addressed in Section 4.15.

Following construction, the areas for natural gas, potable water, transmission, sulfuric acid, methanol, water supply, and hydrogen linears would be restored. Any areas of soil exposed during construction would be returned to their original condition or would be revegetated. The potential alternative route for the transmission line on the west side of Louisiana Pigment is also an industrial area, which would be returned to its original condition or revegetated after construction.

Routine operation of the linears would not be expected to impact surface water resources. Occasional maintenance may require access to buried portions of the utilities; however, BMPs such as strategic placement of silt fencing and temporary drainage controls would be used to avoid any indirect impacts (e.g., sedimentation and turbidity) on adjacent surface waters. There is also the potential for surface water contamination to occur from accidental spills or vehicle leaks during maintenance activities; however, the implementation of BMPs and an SPCC plan would reduce or avoid potential impacts. The potential risk of an accidental release from the pipelines is addressed in Section 4.15.

Floodplains and Wetlands

Following construction, the only aboveground features that would be in the floodplain would be the methanol and sulfuric acid storage tanks. No new structures would be installed during operation. Therefore, no impacts to floodplains would occur during operations.

Due to the relatively narrow width of the permanent pipeline ROW (approximately 50 feet), no measurable alteration of infiltration rates would occur during pipeline maintenance activities. Therefore, no substantial decrease in the volume of surface water that flows downstream would result. Because the pipelines would be buried, fill above the existing ground elevations would not occur. There would be no permanent effect on surface storm water flow patterns or flooding or conflict with applicable local storm water management plans.

4.4.3 Lake Charles CCS Project

4.4.3.1 CO₂ Capture and Compression Facilities

4.4.3.1.1 Construction

The construction of the LCCE Gasification plant includes construction of the Lake Charles CCS project CO₂ capture and compression facilities. Since the impacts are not severable, the effects on surface water, floodplains, and wetlands for the CO₂ capture and compression facilities are described in Section 4.4.2.1.1.

4.4.3.1.2 Operation

Surface Water

The LCCE Gasification plant would supply water to the Lake Charles CCS project CO₂ capture and compression facilities. The CO₂ capture and compression facilities require approximately 10%, or 1.2 MGD of the LCCE Gasification plant's raw water consumption. Because the LCCE Gasification plant's withdrawal would have no or negligible impact on the surface water availability as described in Section 4.4.2.1.1, the CO₂ capture and compression facilities would have no or negligible impact on the use of surface waters or surface water quality.

Floodplains and Wetlands

Operations would not result in additional structures in the floodplain, filling of wetlands, or alteration of infiltration rates that would increase volumes downstream. Operations would be similar to those described in Section 4.4.2.2.1.

4.4.3.2 CO₂ Pipeline

4.4.3.2.1 Proposed Route

Construction

Surface Water. Pipeline construction has the potential to impact surface water quality through temporary erosion and sedimentation, hydrostatic testing of the pipeline before placing the pipeline into service, and by accidental spills of lubricants and/or chemicals used during pipeline construction. Potential surface water impacts resulting from pipeline construction would occur during pipeline crossing of surface waters. The CO₂ pipeline would cross the surface waters listed in Tables 4.4-6.

Table 4.4-6 Surface Water Crossings of the CO₂ Pipeline

Description	Type	Length (feet)
Bayou D'Inde	HDD	1400
Houston River	HDD	4200

Denbury would use HDD to cross the Bayou D'Inde and the Houston River to minimize environmental impacts. However, a potential exists for environmental impacts, such as turbidity and deposition of drilling muds, which can accidentally occur from the inadvertent back up of drilling muds during the drilling process. These potential impacts are reported immediately and cleaned up, typically with full restoration as part of an HDD failure contingency plan and/or drilling mud disposal plan. The applicability of this method is subject to a variety of site-specific physical and engineering factors and specified in the actual permit to be obtained for pipeline installation. Therefore, this method is applicable to water bodies with conditions determined to

be suitable and after extensive assessment and permitting for both environmental and engineering considerations. These impacts would be temporary and could extend downstream, depending on flow and mixing conditions.

BMPs, including a combination of stabilization and structural erosion and sediment control methods, would reduce these temporary impacts by controlling sedimentation and turbidity and restoring stream crossings to their original grade to stabilize stream banks following construction. Key aspects of the BMPs are to control surface and subsurface slope drainage, minimize slope erosion, and minimize or prevent channel erosion at stream crossings. Specific types of structural BMPs include installing temporary control structures such as sediment traps and filter fences. Effective drainage and erosion control would also further minimize impacts on surface waters. The accidental release of fuels, lubricants, and coolants used by heavy equipment during pipeline installation could cause an impact to water quality. An SPCC plan, however, would minimize the potential impact of spills of hazardous materials and would minimize the potential for impacts to surface waters during construction.

Denbury applied for USACE permits for the CO₂ pipeline to cross waters of the U.S., including associated wetlands. The USACE is reviewing the application. Prior to pipeline construction, an NPDES General Permit a Storm Water Discharges from Construction Activities from LDEQ and a SWPPP would be required when more than 1 acre of land is disturbed. Prior to being placed in service, all components in the high-pressure pipeline systems require hydrostatic testing to USDOT standards, in accordance with 49 CFR Part 192. Hydrostatic test water would be tested, and if necessary, filtered prior to discharge. Test water is freshwater and would be tested for contaminants and discharged using energy-dissipation and filtration devices. Discharge points would be permitted and located within well-vegetated upland areas within the construction corridor. Depending on the segment location, water used for hydrostatic testing of the pipeline would be obtained from four water bodies or purchased from municipal supplies, as shown in Table 4.4-7 below. To minimize water use impacts, Denbury would limit withdrawal rates of water from flowing streams to the lesser of 10 percent of the stream's flow at the time of withdrawal or to the withdrawal permit stipulations. Therefore, no decrease in the local water supply or water quality would occur in the proposed action area. No changes in the availability of surface water for current or future uses are anticipated as a result of pipeline construction.

Floodplains. Due to the relatively narrow nature of the permanent pipeline ROW and the temporary construction ROW, no alteration of infiltration rates would be expected. Therefore, no substantial decrease in the volume of surface water that flows downstream would result. The proposed route would permanently impact 14.98 acres and temporarily impact 13.23 acres of 100-year floodplain (CH2M Hill 2011).

Denbury would comply with the terms of the applicable permits such that pipeline construction would not significantly alter storm water discharges, nor would it adversely affect the floodplain. Because the pipeline would be buried, it would not have a permanent effect on surface storm water flow patterns or flooding and would not conflict with applicable local storm water management plans.

Table 4.4-7 Hydrostatic Test Water Information for the Lake Charles CO₂ Pipeline

Segment	Test Location	MP	Length (feet) ^a	Volume (gallons)	Potential Water Source(s) ^b	Potential Discharge Site(s) ^c
Mainline						
Mainline	Bayou d'Inde	0.0	43,079	408,906	Bayou d'Inde	Bayou d'Inde
HDD Segments						
LA Pigment	Bayou d'Inde	0.3	3,400	31,273	Bayou d'Inde	Bayou d'Inde
Bayou d'Inde	Bayou d'Inde	1.0	1,400	12,877	Bayou d'Inde	Bayou d'Inde
I-10	I-10 HDD Exit Point	2.5	1,100	10,118	Municipal Water Source – Trucked-In	Upland Land Disposal at site
Sabine Canal	Sabine Canal	5.5	750	6,899	Sabine Canal	Sabine Canal
Hardey Cemetery	Cemetery HDD Exit Point	5.6	275	2,529	Municipal Water Source – Trucked-In	Upland Land Disposal at site.
Houston River	Houston River	7.4	4,200	38,632	Houston River	Houston River
Bankens Road	Bankens Road HDD Enter Point	9.5	1,750	16,097	Municipal Water Source – Trucked-In	Upland Land Disposal at site.
Napoleon Road/Kansas City Railroad	Napoleon Road HDD Enter Point	3.6	500	4,959	Municipal Water Source – Trucked-In	Upland Land Disposal at site.
Kansas City Railroad	Railroad HDD Exit Point	8.1	300	2,759	Municipal Water Source – Trucked-In	Upland Land Disposal at site.
High Hope Road	High Hope Road HDD Enter Point	8.6	500	4,959	Municipal Water Source – Trucked-In	Upland Land Disposal at site.
Road Bore						
12 Road Bore Crossings ^d	Road Crossings	Unknown	1,100	10,100	Municipal Water Source – Trucked-In	Upland Land Disposal at site.
Total			58,354	550,108		

^a Lengths adjusted as necessary to include effects of route variances. Actual test segment lengths and their water source and water discharge locations would be determined during the detailed design phase and noted in the Pipeline Hydrostatic Test Plan.

^b Withdrawal rates of water from flowing streams would be limited to the lesser of 10 % of the stream's flow at the time of withdrawal or to the withdrawal permit stipulations.

^c After testing is completed, water typically would be discharged back to the water source or to an approved upland location within the same watershed or to a location required by permit.

^d The 12 HDD bore crossings are typically much shorter (usually 40 to 50 feet) and would require only about 400-500 gallons of water for hydro-testing, which could be trucked in and disposed of on land. The two longest HDD bores are 225 and 360 feet and would require about 2,000 to 4,000 gallons, which also could be trucked in and disposed of on land.

Pipelines permitted and constructed under the USACE permit and local building permits are prohibited from altering a floodway or floodplain or otherwise impeding or redirecting flows in a manner that would increase the potential for floods or impacts on human health, the environment, or personal property, nor would construction conflict with applicable local flood management plans or parish ordinances. Therefore, the permitted pipeline would not conflict with FEMA's national standard for floodplain management.

Wetlands. Denbury applied for USACE permits to cross waters of the U.S., including associated wetlands. The USACE is reviewing the application. Construction of the proposed pipeline across wetlands would result in short-term disturbances to wetland hydrology and, where new permanent ROW is required, long-term disturbance in the form of functional conversion from forested or scrub-shrub wetlands to emergent wetlands. Impacts from in-stream disturbances would occur during construction and restoration activities at each pipeline crossing of a water body. A majority of the route would be collocated within existing utility easements, as identified in Table 4.4-8 below.

Table 4.4-8 Collocation of the Proposed Lake Charles Pipeline Lateral Project with Existing Easements and Rights-of-Way

County/State/Owner	Begin Milepost	End Milepost	Total Miles Paralleled	Type of Easement	Width of Existing Easement (feet)	Direction from Existing Easement	Width Used for Temporary Construction Easement (feet) ^a
Gulf States Utilities	0.5	0.8	0.3	Power Line	75 ^b	West	0
Calcasieu Parish	1.4	2.0	0.6	Road (Bayou D'Inde Pass / Prater Road)	55 ^c	East	0
Shell Pipeline Easement	2.5	2.9	0.4	Pipeline	30 ^b	East	0
Petrologistics Easement	2.9	3.3	0.4	Pipeline	25 ^b	Northwest	0
Air Products Easement	3.9	4.5	0.6	Pipeline	30 ^b	Southwest	0 to 25
Kansas City Railroad	4.5	5.6	1.1	Railroad	100 ^c	Southwest	0 to 7
Beauregard Electric	5.6	6.8	1.2	Power Line	55 ^c	Southwest	30 to 50
Kansas City Railroad	6.8	7.4	0.6	Railroad	100 ^c	Southwest	0 to 20
Air Products Easement	7.4	7.5	0.1	Pipeline	35 ^b	East	11 to 14
Air Products Easement	7.6	7.7	0.1	Pipeline	35 ^b	East	7 to 10
Kansas City Railroad	7.7	8.1	0.4	Railroad	100 ^c	West	25 to 35
Entergy Easement	8.4	10.1	1.7	Power Line	100 ^b	Southwest	0
Calcasieu Parish	10.7	11.1	0.4	Road (Bankens Road)	60 ^c	North	0 to 11
Total Pipeline Miles Paralleled			7.9^d				

Source: CH2M Hill 2011.

- ^a Width is based on the potential of overlap with the existing easement. Consultations and legal agreements with existing easement owners would be finalized prior to construction.
- ^b Easement width was estimated based on the county's tax lot/parcel data set.
- ^c Existing easement width was estimated from the maintained corridor width detailed on aerial photography.
- ^d Not all listed easement/ROW calculations are counted toward the total collocation length of the project. Where the proposed project route is collocated with two or more additional ROWs, due to collocation of two or more landowners at one time, only one easement/ROW collocation is counted toward the total collocation length of the Denbury project.

Denbury proposes to use open-cut pipeline crossing techniques on a majority of the stream crossings: minor waterbodies would be crossed using conventional open-cut crossing techniques, including both wet and dry trenching methods, followed by restoration. All major waterbodies would be crossed using HDD techniques (CH2M Hill 2011). HDD techniques limit the impact to waterbodies, although a potential exists for environmental impacts, such as turbidity and deposition of drilling muds, which can accidentally occur from the inadvertent back up of drilling muds during the drilling process. These potential impacts are reported immediately and cleaned up typically with full restoration as part of an HDD failure contingency plan and/or drilling mud disposal plan. As shown in Table 4.4-9, two major waterbody crossings and 19 minor waterbody crossings have been identified by Denbury (Denbury 2013). Therefore, with the use of HDD techniques and restoration following conventional open-cut crossing techniques, no impacts on waterbodies are likely to occur during pipeline construction. Section 4.4.2.1.2 describes these crossing methods for pipelines.

Table 4.4-9 Summary of Potential Surface Water, Wetland, and Floodplain Impacts of the Proposed CO₂ Pipeline Route

	Proposed
Number of major waterbody crossings	2
Number of minor waterbody crossings	19
Permanent wetland impact (acres) ^a	4.00
Total long-term temporary wetland impacts (acres) ^b	6.79
Permanent floodplain impact (acres) ^c	14.98

Source: Denbury 2013; USACE 2012

^a Permanent wetland impact occurs when a wetland is converted to an upland feature, or when a forested or scrub-shrub wetland types is converted permanently to an emergent wetland.

^b Temporary clearing impact allows revegetate back to forested/scrub-shrub wetlands within the temporary construction ROW.

^c Floodplain impacts also include additional 13.23 acres of temporary impacts

The CO₂ pipeline ROW contains a total of 19.02 acres of wetlands, of which 10.34 acres are forested wetlands, 8.23 acres are emergent wetlands, and 0.45 acre is scrub-shrub wetland. During pipeline installation, some of these wetlands would be impacted, either permanently or temporarily, by construction activities. A permanent wetland impact is when a wetland is converted to an upland feature, or when a forested or scrub-shrub wetland is converted permanently to an emergent wetland. A temporary wetland impact is when a wetland, regardless of type, is allowed to revegetate to its preconstruction type. Construction of the CO₂ pipeline along the proposed route would temporarily impact approximately 6.79 acres of wetlands and permanently impact 4.00 acres of wetlands, as shown in Table 4.4-9. Approximately 3.80 acres of forested wetland and 0.20 acre of scrub-shrub wetland, or a total of 4.00 acres would be permanently converted into emergent wetland within the permanent ROW by construction and operation of the pipeline. Approximately 6.54 acres of forested wetland and 0.25 acre of scrub-shrub wetland, or a total of 6.79 acres, would be temporarily cleared during construction but allowed to revegetate to forested and scrub-shrub wetlands in the long term following construction. To minimize impacts on waters of the U.S., including wetlands, the corridor would be reduced to 75 feet from 95 feet, and consist of 50 feet of permanent ROW and 25 feet of temporary ROW through wetlands.

Denbury would perform construction in accordance with required federal and state permits and would comply with standards or mitigations stipulated in the permits such that impacts on wetlands would be minor. Denbury would, depending on location-specific restrictions, available space, and regulatory constraints that may exist, implement minimization measures to minimize impacts on surface water from pipeline construction activities (CH2M Hill 2011). Denbury’s minimization measures include the following:

- Strip topsoil separately, stockpile for re-use during restoration, and place soils derived from construction work at locations of smaller water body crossings within the pipeline construction ROW at least 10 feet from the water’s edge and separated with silt fencing, or in additional specified work areas separated from the surface water body.
- Maintain the minimum required buffer distance from water bodies during refueling of construction equipment, or, when this cannot be achieved, the construction contractor would employ secondary containment methods and would establish other appropriate spill prevention and cleanup measures to minimize the potential for any accidental spill-related impacts.
- Adhere to the following guidelines when in proximity to any major water bodies or delineated wetlands for which additional temporary workspace would be necessary for staging:
 - Locate additional staging areas, additional soil storage areas, or other additional work areas at least 50 feet away from the water’s edge, unless the adjacent upland area is cultivated cropland or other disturbed land, in which case the buffer may be less;
 - Minimize the clearing of vegetation between any additional required staging/storage areas and the water body or within the ROW of the pipeline; and
 - Establish and clearly mark buffer areas separating water bodies from designated refueling and staging areas.

Mitigation for impacts on waters of the U.S., including wetlands, would include on-site restoration of wetlands temporarily impacted by construction, and the purchase of mitigation credits from approved wetland mitigation banks in the affected watersheds (i.e., the Lower Calcasieu watershed (Hydrological Unit Code [HUC] 08080206) and the West Fork Calcasieu watershed (HUC 08080205) (CH2M Hill 2011). Wetlands temporarily cleared for construction would be restored to pre-existing contours and hydrology and allowed to revegetate to pre-construction existing conditions. To compensate for long-term temporary impacts and permanent conversion of forested and scrub-shrub wetlands to emergent wetlands, Denbury would purchase credits from wetland mitigation banks approved by the USACE in the affected watershed areas. Table 4.4-10 summarizes CO₂ pipeline construction impacts expected to be offset by mitigation.

Table 4.4-10 Total Wetland Impacts From the CO₂ Pipeline to be Offset by Mitigation

Wetland Type	Permanent Conversion to PEM Wetland (acres) ^a	Long-Term Temporary (acres impacted) ^b
Forested	3.80	6.54
Scrub-Shrub	0.20	0.25
Total Impacts to be Offset by Mitigation	4.00	6.79

Operation

Surface Water. Normal operation of the pipeline corridor would generally not affect surface waters. Occasional maintenance activities may require access to buried portions of the utilities; however, BMPs such as strategic placement of silt fencing and temporary drainage controls would be used to avoid any indirect impacts (e.g., sedimentation and turbidity) on adjacent surface waters. Surface water impacts also could result from an accidental spill during maintenance activities; however, the implementation of BMPs and an SPCC plan would reduce or prevent such impacts.

Floodplains and Wetlands. No floodplain impacts are anticipated from preferred CO₂ pipeline operations. Due to the relatively narrow nature of the permanent pipeline ROW, no measurable alteration of infiltration rates would occur during pipeline maintenance activities. Therefore, no substantial decrease in the volume of surface water that flows downstream would result. Because the pipeline would be buried, it would not result in a fill above the existing ground elevations, have a permanent effect on surface storm water flow patterns or flooding, nor conflict with applicable local storm water management plans. No wetland fills would occur as a result of normal CO₂ pipeline operations.

4.4.3.2.2 Alternative Route B

Construction

Surface Water. Table 4.4-11 summarizes the surface water impacts of the alternative and proposed CO₂ pipeline routes. Construction along the alternative pipeline route would utilize the same construction means described above for the proposed route to avoid or minimize impacts on navigable waters, wetlands, water quality, and supply. Impacts resulting from construction of the pipeline along the alternative route would be similar to those discussed above for the proposed route. The alternative route would involve two major waterbody crossings and nine perennial waterbody crossings (versus two major water body crossing and 19 minor perennial streams crossings for the proposed route).

Table 4.4-11 Summary of Potential Surface Water, Wetland, and Floodplain Impacts of the Alternative CO₂ Pipeline Route Compared to the Proposed Route, acres

	Alternative	Proposed
Number of major water body crossings	2	2
Number of minor water body crossings	9	19
Total wetlands in ROW	55.8	19.02
Total Permanent and Temporary Wetland Impacts	26.29	10.79
Floodplain Permanent Impact	16.67	14.98
Floodplain Temporary Impact	14.57	13.23

Source: CH2M Hill 2011; Denbury 2013; USACE 2012

Floodplains. Construction of the alternative CO₂ pipeline would result in 16.67 acres of permanent floodplain impacts and 14.57 acres of temporary floodplain impacts (verses 14.98 acres of permanent impacts and 13.23 acres of temporarily impacts on the 100-year floodplain for the preferred route) (CH2M Hill 2011). Due to the relatively narrow nature of the permanent pipeline ROW and the temporary construction ROW, no alteration of infiltration rates would be expected. Therefore, no substantial decrease in the volume of surface water that flows downstream would result. However, construction within the 100-year floodplain would require same process as described in Section 4.4.3.2.1 for construction of the preferred CO₂ pipeline route.

Wetlands. The alternative pipeline route contains 55.8 acres of wetlands (49.6 acres forested) within the construction corridor (CH2M Hill 2011). The alternative route would impact 26.29 acres of wetland (versus 4.00 acres of permanent conversion of forested wetland to emergent wetland for the proposed route).

Operation

Operation of the pipeline along the alternative route would be the same as described above for proposed pipeline route and would result in the same level and type of impacts as described above in Section 4.4.2.2.1.2.

4.4.3.3 West Hastings Research MVA Program

Surface Water

The research MVA activities would occur at an ongoing commercial EOR operation in the West Hastings oil field. As described in Section 2.4.3, construction activities would be limited to well reconversion/reconstruction activities. All MVA activities would be temporary. Field work related to reworking of wells would involve the use of a workover rig and temporary facilities and improvements placed on the well pad ground surface within an area measuring approximately 150 by 150 feet in the immediate vicinity of each existing well pad. The impact from potential spills related to tanks (temporary steel tanks for holding wellbore fluids) would be negligible, since the existing drill pads are bermed and designed to contain fluids. Therefore, the MVA activities would not involve the removal or injection of any materials that would result in changes in surface water availability or runoff or result in significant effluent releases.

Floodplains

The research MVA project area includes Cowart Creek, which drains to the northeast, and Chigger Creek, which drains to the southeast. The West Hastings research MVA project area is shown on FEMA FIRM Panels 48039C0135I (revised September 22, 1999), 48039C0045J (revised September 22, 1999), 48039C0065J (revised September 22, 1999), and 48039C0175I (revised September 22, 1999). Areas identified as Special Flood Hazards inundated by the 100-year floods (Zones A, AE, and AO) occur within 100 to 2,000 feet of Chigger Creek and Cowart Creek. The southern approximately one-third of the research MVA area, including two proposed well locations, is located within the 100-year floodplain of Chigger Creek. However, MVA activities would not increase the potential for floods, alter a floodway or floodplain, or otherwise impede or redirect flows such that human health, the environment, or personal property could be affected.

Wetlands

The NWI indicates that several wetlands are present within the West Hastings oil field MVA area, mainly in the vicinity of Chigger Creek. Proposed wells would be located outside of wetland areas, and BMPs would be used to prevent runoff from entering wetlands outside of construction areas (APCI 2011). Therefore, no infill of wetlands or reduction in wetland value would result.

All activities related to the on-going commercial operations at the West Hastings oil field will be permitted by the RRC and implemented for Denbury's commercial EOR operations. The on-going commercial EOR activities and associated monitoring will be completed by Denbury regardless of the implementation of the DOE-funded research MVA activities. The use of existing wells for groundwater monitoring may require dewatering of the wells. The volume of water (fresh and/or saline) produced from dewatering would be less than or comparable to that associated with Denbury's current commercial EOR operations. Water from dewatering of wells would be captured from the wells, transported by truck, and re-injected into Class II wells operated by Denbury at the Hastings oil field.

Drilling mud and associated wastes are also generated during drilling operations and are land farmed on site in accordance with RRC's regulations (Texas Administrative Code Title 16 Rule 3.8). Denbury currently applies a series of BMPs and policies in its ongoing EOR operations in the Hastings oil field in order to minimize waste generation and minimize the discharge of pollutants in storm water runoff. Denbury's *Waste Management/Minimization Plan* proscribes practices and policies for the proper management and minimization of each type of waste stream generated by Denbury. The disposal methods described above would not involve discharges that could affect surface water quality.

4.4.4 Summary of Impacts

Tables 4.4-12 and 4.4-13 present summaries of the surface water, floodplains, and wetlands impacts and minimization measures for the LCCE Gasification plant and the Lake Charles CCS project.

Table 4.4-12 Summary of Potential Impacts on Surface Water, Floodplains, and Wetlands and Minimization Measures for LCCE Gasification Plant and Off-site Activities

Potential Impacts	Minimization Measure(s)
<p>Construction: Minor Construction may introduce contaminants to storm water runoff through excavation, material delivery and storage, concrete washout, waste generation, and equipment and vehicle use and storage. Wetland impacts were addressed through off-site mitigation banking of 26.2 acres of wetlands. Water required for construction of the parking area would include one water truck supplying an average of 2,000 gallon per day for 3 years. Additional floodplain and wetland impacts may occur at the 40-acre site of the equipment laydown area and methanol/sulfuric acid storage are dependent on the final location selected.</p> <p>The water supply pipeline would cross Bayou d’Inde and Bayou Verdine and impact 3.55 acres of wetlands. The hydrogen pipeline would cross Bayou d’Inde, the Sabine River Canal, and two additional waterbodies using HDD construction methods and impact 3.59 acres of wetlands. Hydrostatic testing of the water supply and hydrogen pipelines would approximately require approximately 193,600 and 412,890 gallons, respectively.</p>	<p>Leucadia would obtain a NPDES General Permit for Storm Water Discharges from Construction Activities and would conduct activities in accordance with the required federal and state permits and would comply with the water quality standards and discharge limitations stipulated in the permits.</p> <p>Leucadia also would follow their SWPPP and BMPs to control erosion, sedimentation, and pollutants in storm water discharges.</p> <p>Leucadia would conduct pipeline construction activities in accordance with the required Hydrostatic Test Discharge Permit</p> <p>Leucadia would prepare an SPCC plan to minimize the potential for impacts to surface waters during construction of the water supply and hydrogen pipelines. Any existing roads used during construction of the pipelines would be returned to original condition. New access roads would be removed and the land restored to original condition.</p> <p>If a water body crossed by the pipelines is determined to be a water of the U.S. (jurisdictional) and the construction impacts on wetlands exceed the applicable thresholds, Leucadia would obtain the necessary USACE permits and perform construction in accordance with the required federal and state permits.</p>
<p>Operation: Negligible Operation would use an annual average maximum of 8,500 GPM, or 12.2 million gallons per day of raw water from Sabine River. Wastewater, including cooling tower blowdown, water treatment reject, and plant drains and would be discharged as directed by the LDEQ LPDES Water Discharge Permit.</p>	<p>Leucadia would conduct activities in accordance with required federal and state permits and would comply with water quality standards and discharge limitations stipulated in the permits.</p>

Table 4.4-13 Summary of Potential Impacts on Surface Water, Floodplains, and Wetlands and Minimization Measures for Lake Charles CCS Project

Potential Impacts	Minimization Measure(s)
<p>Construction and Operation of the CO₂ Capture and Compression Facilities: Negligible Included in the LCCE Gasification plant (see Table 4.4-12)</p>	<p>Included in the LCCE Gasification plant (see Table 4.4-12)</p>
<p>Construction of the CO₂ Pipeline: Minor The CO₂ pipeline would cross Bayou D'Inde and the Houston River using HDD construction methods. Pipeline route would potentially permanently impact 9.98 acres and temporarily impact 9.02 acres of wetland and permanently impact 14.98 acres and temporarily impact 13.23 acres of 100-year floodplain. Approximately 550,100 gallons of water for hydrostatic testing of the pipeline would be obtained from local water bodies or purchased from municipal supplies</p>	<p>Denbury would obtain a NPDES General Permit for Storm Water Discharges from Construction Activities when more than 1 acre of land would be disturbed. Denbury would conduct activities in accordance with the required federal and state permits.</p> <p>Denbury would implement measures to minimize impacts on surface water from pipeline construction activities including stockpiling and reuse of topsoil, maintaining the required buffer distance from water bodies during refueling of equipment, employment of secondary containment techniques, if necessary, locating additional storage areas at least 50 feet away from the water's edge, and minimizing the clearing of vegetation.</p>
<p>Construction of the Alternative Pipeline: Minor The alternative CO₂ pipeline would cross two major waterbodies; impact 26.3 acres of wetland and permanently impact 16.67 acres and temporarily impact 14.57 acres of 100-year floodplain.</p>	<p>The same minimization measures would be used as described above.</p>
<p>Operation of the CO₂ Pipeline or Alternative Pipeline: Negligible Periodic maintenance and vehicle traffic would occur.</p>	<p>Denbury would implement BMPs and their SPCC plan, as necessary, during maintenance activities.</p>
<p>Operation of the West Hastings research MVA program: Negligible Use of existing wells for groundwater monitoring may require dewatering of the wells; produced water would be re-injected into an existing disposal well.</p>	<p>No minimization measures would be necessary.</p>

4.5 Groundwater Impacts

4.5.1 Factors Considered for Assessing Impacts

DOE assessed the potential for impacts on groundwater based on whether the proposed project or connected action would directly or indirectly cause:

- A decrease in the quality of the groundwater used by existing water rights holders;
- Depletion of groundwater supplies on a scale that would affect available capacity;
- Interference with groundwater recharge;
- Conflict with established water rights, allocations, or regulations protecting groundwater for future beneficial uses; or
- Conflict with regional or local aquifer management plans or the goals of governmental water authorities.

As part of the NEPA compliance process, DOE also evaluated the potential impacts of the proposed action and its alternatives in accordance with the Safe Drinking Water Act (SDWA), as amended (42 U.S.C. § 300f et seq.) and state and local regulations, ordinances, and programs. The Safe Drinking Water Act programs include the Sole Source Aquifer Program, the Wellhead Protection Program, and the Underground Injection Control Program. The Safe Drinking Water Act Amendments of 1986 created the Wellhead Protection Program. Created in 1989, Wellhead Protection is a voluntary program designed to protect the quality of public drinking water supplies obtained from community water wells. A "Drinking Water Protection Area" is the surface and subsurface area surrounding a water well. "Wellhead Protection Areas" are now more commonly referred to as "Drinking Water Protection Areas." LDEQ implements the Wellhead Protection Program through its Drinking Water Protection Program. LDEQ delineates an area around a wellhead called a "drinking water protection area." This area around the well ranges in radius from 1,000 feet to 1 mile, depending on the well depth.

This analysis considers impacts to both shallow, unconfined groundwater and the deeper, confined Chicot aquifer (see Section 3.5). Groundwater in the shallow unconfined aquifer is 1 to 3 feet bgs. Drinking water sources in the Chicot aquifer range from 205 feet to 850 feet bgs. Groundwater will not be used as water source during construction activities. Therefore, the proposed construction would not deplete groundwater supplies that would affect available capacity.

4.5.2 LCCE Gasification (Connected Action)

4.5.2.1 Construction

4.5.2.1.1 Gasification Plant

There would be no onsite discharge to groundwater during the construction process. The fill material and gravel surfaces installed during construction would provide a confining layer that would directly or indirectly protect the shallow unconfined groundwater aquifer. The addition of impermeable surfaces over the 70-acre site, including internal roads, equipment foundations, and buildings would further separate surface activities from the surrounding shallow groundwater aquifer.

The 70-acre site is small compared with the larger recharge area of the shallow sand aquifer, which is the 2-million-plus acre infiltration area of the Calcasieu River basin, surrounding marshes, river bed discharges, and open water body leakage from nearby Prien Lake. Leucadia would use surface water from the City of Sulphur and would not use groundwater during construction. The Chicot aquifer would be protected from any surface construction activities by its depth (more than 200 feet bgs) and the intervening clay layer.

Leucadia would prepare a site-specific SWPPP as described in Section 4.4.2.1.1., including measures to reduce the risk of spills and protect groundwater quality from all construction activities. Leucadia would also follow the requirements and procedures outlined in the SPCC Plan for storage of petroleum products, such as fuel. Storm water runoff from construction would occur in compliance with an LPDES construction general permit. Petroleum-based materials and wastes generated during construction would be stored in accumulation areas within secondary containment to prevent spills and unintentional releases to groundwater. As such, impacts on groundwater resources from construction of the LCCE Gasification plant are expected to be negligible.

4.5.2.1.2 Off-Site Activities

Off-site activities would not use groundwater. Construction activities would be separated from the Chicot aquifer groundwater by the extent of its 200 to more than 700-foot depth. Off-site construction activities would not decrease groundwater quality in the Chicot aquifer, deplete groundwater supply on a scale that would affect capacity, or conflict with established water rights or local and regional groundwater management plans.

Off-site activities would involve clearing and excavation activities. Excavations associated with construction of linears would be trenched to depths of less than 6 feet and may intersect the shallow unconfined aquifer (at 1 to 3 feet bgs). Construction techniques using HDD would also intersect the shallow unconfined aquifer. The area of each off-site activity is small compared with the larger recharge area of the shallow sand aquifer, which is the 2-million-plus acre infiltration area of the Calcasieu River basin. Off-site construction activities would result in temporary, negligible impacts on groundwater recharge.

Construction staff would use the construction parking area for personal vehicles during the 40 month construction period. The gravel surface of the construction parking area would be less permeable than the current vegetative cover on the site; however, its permeability would allow approximately 50% infiltration of storm water into the shallow sand aquifer because open-graded crushed stone of all sizes has a 38 to 40% void space, allowing for substantial subsurface water storage and would be laid on a relatively flat slope, generally 5% or flatter (MDE 2000). During construction, incidental drips and leaks of oil, lubricants, and fuel from construction staff vehicles could occur. Contact with gravel and compacted soil reduces the migration of these contaminants and reduces the potential to affect shallow groundwater quality. No hazardous materials would be stored at the construction parking area. Leucadia would follow the requirements and procedures outlined in the SPCC Plan for all proposed construction activities. Storm water runoff from construction would occur in compliance with an LPDES construction general permit.

Construction activities for the equipment laydown area would be similar to the construction parking area, except that fewer vehicles would use the site during the 40 month construction and commissioning period.

Construction of the natural gas, potable water, electric transmission, sulfuric acid, and methanol lines would typically require excavations to depths of less than 6 feet and may intersect the shallow unconfined aquifer that occurs 1 to 3 feet bgs. Construction techniques using HDD would also intersect the shallow unconfined aquifer. These construction activities, occurring over an approximate period of one to two months, may expose groundwater to surface runoff and by mixing sediments with the shallow groundwater. Small, incidental hazardous material or petroleum spills may occur during the pipeline construction process. Each linear would be approximately 0.5 miles in length and each involve approximately 1.5 acres for a total of approximately 6 acres being affected during construction. The 6 acres impacted by construction is extremely small compared to the greater than 2 million acres size of the Calcasieu River basin, which is the extent of the shallow groundwater recharge.

Construction of the water supply and hydrogen pipelines would involve site clearing, trenching, and backfilling of soil once the pipelines are installed below the ground surface. Construction, occurring over an approximate period of three months, would typically require trenching to depths of less than six feet and may intersect the shallow unconfined aquifer that occurs 1 to 3 feet below ground surface. As described in Section 4.4.2.1.2, HDD would be used where pipelines cross designated water bodies. HDD drilling fluids, consisting of bentonite, a naturally occurring clay, and various polymers and additives, depending upon the contractor, would comply with National Sanitation Foundation's NSF/ANSI Standard 60, as safe and meeting acceptable levels of impurities. These construction activities could expose groundwater to surface runoff and mixing of sediments with the shallow groundwater. Incidental drips and leaks from construction equipment and/or vehicles or spills of material or petroleum products could occur during construction.

The water supply pipeline would affect approximately 24 acres of land. The hydrogen pipeline would affect approximately 77 acres of land. The 101 acres impacted by construction is small compared to the greater than 2 million acres size of the shallow groundwater recharge area. Leucadia would follow the requirements and procedures outlined in the SPCC plan for all proposed construction activities. The pipeline construction contractor(s) would manage any fuels and lubricants in accordance with the project-specific SPCC Plan, which would require immediate cleanup of incidental spills. Storm water runoff from construction would occur in compliance with an LPDES construction general permit. Leucadia would implement BMPs for storing and handling of all fuels, lubricants, etc. and proper maintenance of vehicles and equipment during construction to reduce incidental drips and leaks. Spills would be cleaned up immediately before they could reach the groundwater.

Construction of the off-site activities would result in temporary, negligible impacts on groundwater quality.

4.5.2.2 Operation

4.5.2.2.1 Gasification Plant

Operation of LLCE Gasification would not require groundwater from either the shallow sand aquifer or Chicot Aquifer. During operation, there is a potential that small amounts of

petroleum, oil, or lubricants could be spilled on soil from maintenance activities and vehicles. Leucadia would develop and implement an SPCC plan to address storage, use, and handling of petroleum products and promptly address spills as required. Leucadia would operate under an LPDES permit(s) and have storm water management measures in place, as described in Sections 4.4.2.2.1 and 4.4.2.2.2, such that normal operations would not result in impacts to groundwater.

4.5.2.2.2 Off-Site Activities

Off-site activities will not use groundwater during operation. Operating activities would be separated from the Chicot aquifer groundwater by the extent of its 200 to more than 700- foot depth and the confining geologic layer. Operation of the off-site areas would not decrease groundwater quality in the Chicot aquifer, deplete groundwater supply on a scale that would affect capacity, or conflict with established water rights or local and regional groundwater management plans.

Occasional maintenance activities may require access to buried portions of the linears or pipelines. Petroleum-based chemicals or fuels would not be used or stored along the proposed route except during maintenance activities. Small, incidental spills of petroleum-based chemicals (e.g., fuels and lubricants) could occur during maintenance. A leak or a spill from the hydrogen pipeline would quickly vaporize. A leak or a spill from the water supply pipeline would allow surface water to infiltrate to groundwater. A leak or spill from the methanol or sulfuric acid pipeline would pool in the area around the leak.

Leucadia would develop and implement an SPCC plan to address storage, use, and handling of hazardous materials and promptly address spills as required. Leucadia and its subcontractors would perform maintenance activities in accordance with Leucadia's SPCC plan to ensure that the potential for spills is minimized, and that any inadvertent spills are remediated quickly and effectively without affecting local groundwater resources. Leucadia would implement BMPs such as strategic placement of silt fencing and temporary drainage controls to avoid indirect impacts on groundwater. Impacts on groundwater quality during operation of the off-site areas would be negligible.

4.5.3 Lake Charles CCS Project

4.5.3.1 CO₂ Capture and Compression Facilities

The CO₂ capture and compression facilities would be constructed and operated within the LCCE Gasification plant site. Construction and operation impacts would be as described above for the LCCE Gasification plant.

4.5.3.2 CO₂ Pipeline

4.5.3.2.1 Proposed Route

Construction

No groundwater would be used during construction of the CO₂ pipeline. The CO₂ pipeline would not be located within the recharge area of the Chicot aquifer. Construction of the CO₂ pipeline would not decrease groundwater quality in the Chicot aquifer, deplete groundwater supply on a scale that would affect capacity, or conflict with established water rights or local and regional groundwater management plans.

Construction activities, occurring over an approximate period of three months, would involve clearing and excavation activities. Excavations associated with construction of the CO₂ pipeline include trenching to depths of less than 6 feet and deeper for HDD and may intersect the shallow unconfined aquifer (at 1 to 3 feet bgs). As described above, HDD drilling muds consist of inert bentonite clay and various polymers and additives that would be certified safe according to NSF/ANSI Standard 60 and would not result in adverse impact to the environment if accidentally discharged during drilling. Construction activities could expose groundwater to surface runoff and mixing of sediments with the shallow groundwater. Incidental drips and leaks from construction equipment and/or vehicles or spills of material or petroleum products could occur during construction.

The area impacted by construction is small compared to the greater than 2 million acres size of the shallow groundwater recharge area. No water supply wells are present within 150 feet of the pipeline corridor. Denbury would follow the requirements and procedures outlined in the SPCC plan for all proposed construction activities. The pipeline construction contractor(s) would manage any fuels and lubricants in accordance with the project-specific SPCC plan, which would require immediate cleanup of incidental spills. Denbury would implement BMPs for storing and handling of all fuels, lubricants, etc. and proper maintenance of vehicles and equipment during construction to reduce incidental drips and leaks. Spills would be cleaned up immediately before they could reach the groundwater. Construction of the CO₂ pipeline would result in temporary, negligible impacts on groundwater quality.

Operation

Occasional maintenance activities may require access to buried portions of the pipeline. Petroleum-based chemicals or fuels would not be used or stored along the proposed pipeline route except during maintenance activities. Small, incidental spills of petroleum-based chemicals (e.g., fuels and lubricants) could occur during maintenance. Denbury and its subcontractors would perform maintenance activities in accordance with Denbury's SPCC Plan to ensure that the potential for spills is minimized, and that any inadvertent spills are remediated quickly and effectively without affecting local groundwater resources. Denbury would implement BMPs such as strategic placement of silt fencing and temporary drainage controls to avoid indirect impacts on groundwater. Operation of the CO₂ pipeline would have negligible impacts to groundwater.

4.5.3.3 Alternative Route B

Construction

Construction of the CO₂ pipeline along alternative route B would utilize the same methods and require the same permits and BMPs as described in Section 4.5.3.2.1 above. Therefore, construction of the CO₂ pipeline using the alternative route would not decrease groundwater quality in the Chicot aquifer, deplete groundwater supply on a scale that would affect capacity, or conflict with established water rights or local and regional groundwater management plans. Construction of the CO₂ pipeline along the alternative route B would result in temporary, negligible impacts on groundwater quality.

Operation

Operation and maintenance of alternative route B would utilize the same methods and follow the same permit and BMPs as described in Section 4.5.3.2.2. No impacts on groundwater would occur during operation of the CO₂ pipeline in the alternative route.

4.5.3.4 West Hastings Research MVA Program

As described in Section 2.4.3, activities would be limited to well reconversion/reconstruction and monitoring activities. Well reconversion/reconstruction of an existing cased well would not impact groundwater because the casing would not be disturbed or destroyed. As explained in Section 3.3.2, the Frio Formation is several thousand feet below the Chicot-Evangeline USDW with the intervening Burkeville Confining System and Catahoula Confining System acting as a confining layer. Accidental spills of fuel, fuel constituents, and other materials onto the ground surface may occur and could potentially impact shallow groundwater resources. Potential impacts to groundwater through infiltration of fluids accidentally spilled or discharged to the ground surface would be avoided or minimized by using BMPs described in Denbury's *Waste Management/Minimization Plan*.

Denbury would examine existing water wells in the West Hastings oil field area for use as groundwater monitoring wells to eliminate the need for additional well drilling. As described in Section 2.4.3, the West Hastings MVA research activities would be conducted in accordance with Denbury's *Waste Management/Minimization Plan* and BMPs and other policies used by Denbury during normal oil exploration, development, and production operations to comply with all applicable regulations and minimize potential impacts.

A stratigraphic and hydrogeologic cross section of the Gulf Coast region (Baker 1979) and information from Denbury indicates that the top of the Frio Formation is approximately 6,600 feet bgs in the area of the West Hastings oil field where research MVA activities would occur. The Evangeline and Chicot aquifers are separated from the Frio Formation by two confining layers, the Burkeville confining system and Catahoula confining system, as described in Section 3.3.2. The groundwater wells constructed in Brazoria County typically have total depths ranging from approximately 60 feet to 1,400 feet. The USDW in the Hastings oil field area is in the subsurface zone at depths of 1,650 feet bgs (Hovorka 2010). As discussed in Section 4.3.3.3, migration of geologically stored CO₂ outside of the confining geologic formations and into groundwater would be unlikely due to the confining nature of the site geology and the distance to the USDW. Denbury's ongoing commercial MVA program and the research MVA program are designed to detect CO₂ migration.

4.5.4 Summary of Impacts

Tables 4.5-1 and 4.5-2 present summaries of the groundwater impacts and minimization measures for the LCCE Gasification plant and the Lake Charles CCS project.

Table 4.5-1 Summary of Potential Impacts on Groundwater and Minimization Measures for LCCE Gasification Plant and Off-site Activities

Potential Impacts	Minimization Measure(s)
<p>Construction: Negligible Horizontal directional drilling for the water supply and hydrogen pipelines may intersect the shallow unconfined aquifer of the Calcasieu River basin. The area impacted by construction is small compared to the greater than 2 million acres size of the shallow groundwater recharge area.</p> <p>Small, incidental drips and leaks of fuels or lubricants could occur from construction equipment or vehicles.</p>	<p>HDD drilling muds consisting of bentonite clay and various polymers and additives would be certified safe according to NSF/ANSI Standard 60.</p> <p>Leucadia would prepare a SWPPP to reduce the risk of spills and protect groundwater quality from all construction activities.</p> <p>Leucadia would operate under an LPDES permit(s). Leucadia would manage spills in accordance with their SPCC Plan and BMPs, such that spills would be cleaned up immediately before they could reach groundwater.</p>
<p>Operation: Negligible Small, incidental drips and leaks of fuels or lubricants could occur from vehicle traffic.</p>	<p>Leucadia would manage spills in accordance with their SPCC Plan.</p>

Table 4.5-2 Summary of Potential Impacts on Groundwater and Minimization Measures for Lake Charles CCS Project

Potential Impacts	Minimization Measure(s)
<p>Construction and Operation of the CO₂ Capture and Compression Facilities: Negligible Included in the LCCE Gasification plant (see Table 4.5-1)</p>	<p>Included in the LCCE Gasification plant (see Table 4.5-1)</p>
<p>Construction of the CO₂ Pipeline or Alternative Pipeline: Negligible Horizontal directional drilling may intersect the shallow unconfined aquifer (1 to 3 feet bgs) of the Calcasieu River basin. The area impacted by construction is small compared to the greater than 2 million acres size of the shallow groundwater recharge area.</p> <p>Small, incidental drips and leaks of fuels or lubricants from construction equipment or vehicles could occur during construction.</p>	<p>HDD drilling muds consisting of bentonite clay and various polymers and additives would be certified safe according to NSF/ANSI Standard 60.</p> <p>Denbury would manage spills in accordance with their SPCC Plan, which would require immediate cleanup of incidental spills. Denbury would also implement BMPs for storage and handling of all fuels, lubricants, etc. to reduce incidental drips and leaks.</p>
<p>Operation of the CO₂ Pipeline or Alternative Pipeline: Negligible Small, incidental drips and leaks of fuels or lubricants could occur during maintenance.</p>	<p>Denbury would manage spills in accordance with their SPCC Plan, which would require immediate cleanup of incidental spills. Denbury would also implement BMPs such as strategic placement of silt fencing and temporary drainage controls.</p>
<p>Operation of the West Hastings research MVA program: Negligible Small, incidental drips and leaks of fuels or lubricants could occur during maintenance.</p>	<p>Denbury would manage spills in accordance with their SPCC Plan.</p>

4.6 Biological Resources

4.6.1 Factors Considered for Assessing Impacts

The DOE assessed the potential for impacts on biological resources based on whether the proposed project or connected action would directly or indirectly:

- cause a violation of the Endangered Species Act (ESA), the Migratory Bird Treaty Act (MBTA), the Bald and Golden Eagle Protection Act, or Executive Order 13186, Responsibilities of Federal Agencies to Protect Migratory Birds;
- conflict with applicable management plans for wildlife and/or wildlife habitat, including aquatic communities;
- result in a substantial long-term loss of threatened or endangered species and/or their habitat;
- degrade biological habitat or interfere with the movement of native or migratory terrestrial or aquatic species;
- encroach on or degrade critical or protected habitat; or
- change the existing local plant or wildlife diversity or substantially alter the local plant and wildlife populations.

This evaluation examines impacts on vegetation, wildlife, aquatic biology, and threatened and endangered species, including impacts from invasive species. The examination uses field studies and desktop analyses performed for the proposed project, published reports, and Geographic Information System (GIS) analysis to determine the maximum extent of potential impacts on vegetation communities and wildlife habitat. Quantitative estimates of potential impacts were calculated using GIS and land cover data. Qualitative assessments were made based on the potential effects to species and habitats from expected attributes of the project.

4.6.2 LCCE Gasification Plant (Connected Action)

4.6.2.1 Construction

4.6.2.1.1 Gasification Plant

Prior to site preparation, the site was occupied by 43.8 acres of upland mixed hardwood-pine forest on the higher elevations, with 26.2 acres of bottomland cypress-tupelo swamp and freshwater emergent marsh in the lower elevations. Leucadia consulted with the Louisiana Department of Fisheries and Wildlife regarding the potential effects on state or federal parks, wildlife refuges, scenic streams, or wildlife management areas at the site, and none were identified (Lester 2009). Therefore, construction would not encroach on or degrade critical or protected habitat.

As described in Section 1.5, the Port of Lake Charles received a USACE Section 404 permit to proceed with site development which included fill of 26.2 acres of wetlands on the site and bulkhead of 2,200 linear feet of riverine shoreline. The loss of 70 acres of wooded habitat, including 26.2 acres of cypress-tupelo forested and emergent freshwater marsh wetlands would alter the local drainage pattern, and affect upland and wetland-dependent plant and wildlife diversity. As described in Section 3.6, threatened or endangered species, including bald eagle, do not occur on the site, nor provide suitable habitat for such species. Therefore, construction

would not result in a substantial long-term loss of threatened or endangered species or their habitat.

Currently, the upper Calcasieu River watershed encompasses approximately 30,710 acres, 3,463 acres of which are deciduous forested wetland and 2,757 acres are mixed forested wetland, totaling 6,220 acres of forested wetland. Within this greater Calcasieu River watershed, the Bayou D'Inde watershed has approximately 2,583 acres of forest remaining. Of this remaining forest in the Bayou D'Inde watershed, in which the proposed project and connected action are located, the forest is already fragmented by Cities Service Highway (SH 108). The proposed project and connected action are contained within an approximately 1,740-acre forested area. The loss of 70 acres within the 1,740 acres of forested area represents 4% of the total area. As described in Section 3.6.2, many migratory birds have been recorded in the area. Because these species need between 7,000 to 100,000 acres to maintain viable nesting populations, this remaining forest tract may not provide the desirable extent of undisturbed forest. However, a larger unbroken forest is located 7 miles to the north along the Houston River corridor and is available for these species. The Houston River corridor watershed is 100,480 acres (40,192 ha) in size and dominated by forested cover (LaDEQ 2001). Therefore, the loss of 70 acres of vegetation within the greater Calcasieu watershed and habitat area would have negligible impacts on biology.

4.6.2.1.2 Off-Site Activities

The proposed construction parking area is mowed on a regular basis and does not provide native plant and wildlife habitat; therefore, construction of the gravel parking area would not substantially alter local flora or fauna. Threatened or endangered species are not present in this area, nor is there any critical habitat for such species. Construction of the parking area would have negligible impacts on biological resources.

Construction of the 40-acre equipment laydown and methanol/sulfuric acid storage area would likely involve clearing and grading, which have the potential to permanently remove native vegetation and wildlife habitat. Conversion of the equipment laydown area to the methanol and sulfuric acid tank storage area would likely require grading and excavating for shallow foundations. Open, undeveloped land in close proximity to the LCCE Gasification site would likely contain forested wetlands that would be cleared by construction. The likely site for the equipment laydown area is contained within an approximately 1,740-acre forested area. The 40 acres within the 1,740 forested area represents a 2.3% loss. There would be a potential to impact local biological resources including interfering with local wildlife movement, changing local plant and animal diversity, and altering local plant and animal populations. Permits required for site development would require a survey of biological resources, quantification of potential impacts, and mitigation, if applicable. Although the final site is not known, it is likely that construction of the equipment laydown and methanol/sulfuric acid storage area would have the potential for minor impacts on biological resources.

The natural gas, potable water, electric transmission (both primary and alternative), sulfuric acid and methanol linears would be constructed within existing maintained ROWs. Therefore, alteration of native local flora and fauna has already occurred and would not occur as a result of this proposed construction. The linears do not contain wetlands or habitat conditions to support threatened and endangered species within a maintained utility ROW. Threatened or endangered species do not use these ROWs. Construction would temporarily change the existing local plant

cover within the ROW, however, following ROW restoration, no long-term impacts to local wildlife diversity or substantial alteration of the local floral and faunal populations would result. No other direct impacts on biological resources would result from construction of these linears.

Construction of the water supply and hydrogen pipelines would require clearing, grading, trenching, backfilling, and restoration. Waterbody crossings have the potential to impact upland and wetland forest vegetation, including bottomland hardwood forests and bald cypress/tupelo swamps, and local resident and migratory terrestrial and aquatic wildlife species. As summarized in Table 4.6-1, the water supply and hydrogen pipelines would impact 18.47 and 62.74 acres of vegetation, respectively. The pipelines were sited as much as practicable within existing utility ROWs to minimize impacts to native plant and wildlife resources. Approximately 76% of the water supply pipeline route and 99% of the hydrogen pipeline route follows existing ROWs. The proposed pipeline routes would cross Bayou Verdine, local drainage tributaries to Bayou Verdine, Bayou D’Inde, and the Houston River and there would be temporary impacts during construction to biological resources due to site clearing, soil excavation, equipment noise, and the presence of humans.

Table 4.6-1 Vegetation Impacts with the Water Supply and Hydrogen Pipeline Routes (acres)

Vegetation Type	Water Supply Route	Hydrogen Route
Evergreen forest	3.35	9.17
Mixed forest	0	0.46
Shrub/scrub	0	17.63
Grassland/herbaceous	0	2.48
Pasture/hay	0	2.88
Cultivated crops	0	0
Woody wetlands	12.76	26.06
Emergent herbaceous wetlands	2.36	4.06
Total	18.47	62.74

Suitable habitat for colonial wading birds may be present along the pipeline route intersections with Bayou D’Inde and around the Houston River. Great blue herons (*Ardea herodias*), yellow-crowned night herons (*Nyctanassa violacea*), snowy egrets (*Egretta thula*), and white ibis (*Eudocimus albus*) could likely be present at these locations. Construction of Segments 1, 4, 6, 8, 10, 12, 16 and 18 of the hydrogen pipeline and segment 8 of the water supply pipeline would potentially impact the aquatic ecology of encountered wetlands and water bodies crossed from the removal of vegetation and disturbances from construction equipment. However, these construction impacts to biological resources associated with wetland and waterbodies would be temporary and avoided or minimized if the HDD construction method is utilized.

Resident wildlife species that use undeveloped portions of the proposed pipeline routes, including birds, would likely relocate to available suitable habitat during construction activities. Migratory birds that use undeveloped forested portions in or adjacent to the proposed pipeline routes would utilize available alternative habitat. Approximately 388 acres of bottomland forest habitat and open marsh occur along the Calcasieu River floodplain about 2 miles to the southeast. Further south of the urban and agricultural developments associated with the towns of Carlyss and Prien, broad expanses of floodplain forested habitat extend along both sides of the

Calcasieu River. Approximately 50 acres of freshwater marsh exist west and north of the site along the Calcasieu Ship Channel and Bayou D'Inde.

As described in Section 3.6.4, the presence of the red-cockaded woodpecker (*Picoides borealis*, state and federally endangered); Louisiana black bear (*Ursus americanus luteolus*, state and federally threatened); bald eagle (*Haliaeetus leucocephalus*, state threatened); and Sprague's pipit (*Anthus spragueii*, federal candidate species) would be unlikely to occur at the site. However, the red-cockaded woodpecker and the bald eagle could potentially be present in the immediate vicinity and specifically in large undeveloped forested areas and forested wetlands adjacent to proposed pipeline routes and waterbody crossings. Construction of Segments 1, 8, 11, 12, 15, 16, and 17 of the hydrogen pipeline and Segment 7 and 8 of the water supply pipeline could temporarily and indirectly impact the red-cockaded woodpecker since forest is adjacent to these segments and this species may reside in larger tracts of undeveloped forested land adjacent to the ROW. Segment 10 of the hydrogen pipeline is forested. Construction in segment 10 would potentially directly impact red-cockaded woodpecker if this species is present within this forest.

Construction of the water supply and hydrogen pipelines would result in the conversion of existing forest to maintained open grassland and would affect the local wildlife communities using these forested habitats, specifically local resident and migratory terrestrial species. Leucadia avoided and minimized adverse impacts on biological resources by locating the pipeline corridors within or adjacent to existing utility ROWs to the extent practicable. As Leucadia finalizes the design of the pipeline corridors and applies for required regulatory approvals for potential wetland impacts, some variations in the route may occur. Prior to construction of the pipelines, federal and state permitting requirements would require site-specific surveys, identification of wetlands and threatened and endangered species habitat, and mitigation, if applicable. Leucadia would perform construction in accordance with required federal and state permits and would comply with standards or mitigations stipulated in the permits such that impacts on vegetation and wildlife would be minimized. Overall, the loss of forested habitat itself would have a minor impact on wildlife and migratory bird species as abundant, comparable habitat is available in the vicinity.

Noise generated by construction activities would also likely cause wildlife species to avoid the construction area. Overall, the disturbances from construction would be temporary, and impacts to wildlife from construction noise would be temporary and minor.

4.6.2.2 Operation

Once in operation, the LCCE Gasification plant and related off-site activities would have no or negligible impacts on biological resources. Long-term maintenance of the water supply and hydrogen pipelines involves routine mowing to prevent invasive species from becoming established and forested species from becoming re-established. Long-term maintenance of the hydrogen pipeline, if it occurs during the breeding season, could cause noise and dislocation of colonial wading birds and species in adjacent forested habitats if determined to be present. However, the impact would be temporary and minor since resident terrestrial species have the ability to relocate. Therefore, within the ROW routine maintenance performed could have temporary, negligible impacts on local wildlife populations from noise and human or vehicle movement. Maintained ROW would not provide suitable habitat for migratory bird species.

4.6.3 Lake Charles CCS Project

4.6.3.1 CO₂ Capture and Compression Facilities

The CO₂ capture and compression facilities would be constructed and operated on approximately 8.6 acres within the larger 70-acre LCCE Gasification plant site. There would be no additional impacts associated with construction and operation of these facilities beyond those discussed in Section 4.6.2.

4.6.3.2 CO₂ Pipeline

4.6.3.2.1 Proposed Route

Construction

During the course of construction of the CO₂ pipeline, forest would be removed and replaced with herbaceous grass cover within the maintained ROW, which would result in reduced forest area and fragmentation of contiguous forest. As summarized in Table 4.6-2 0.91 acres of forested and scrub-shrub wetlands would be permanently converted into emergent wetlands within the permanent ROW by the construction and operation of the pipeline, while 1.96 acres of forested (woody) wetlands would be cleared during construction but allowed to revegetate to forested wetlands following construction. This would result in some incremental degradation of habitat and could affect the movement of native or migratory terrestrial or aquatic species that require unbroken forest cover. Removal of native vegetation and soil disturbance has the potential to introduce new or invasive species to an area or substantially expand extant populations of invasive species.

Table 4.6-2 Vegetation Impacts for the CO₂ Pipeline (acres)

Vegetation Type	Potential Impacts
Evergreen forest	10.21
Shrub/scrub	17.65
Grassland/herbaceous	2.1
Woody wetlands	1.96
Emergent herbaceous wetlands	0.91
Total	32.83

Aquatic biological resources associated with open-water bodies and wetlands traversed by the pipeline ROW could be disturbed by construction activities. These impacts could include loss of wetland area and function. The loss of habitat results in the loss of flora and fauna individuals, however this would have a negligible impact on the overall populations as large habitat areas remain in the vicinity, as described in Section 4.6.2.1.1, and the majority of wildlife has the ability to relocate. The use of the HDD method could result in an inadvertent discharge of drilling fluids (muds and lubricants). Inadvertent discharge of drilling muds would result in covering an area with a relatively thin layer of mud. The drilling muds would consist of clays, in situ site soils, and non-toxic materials. Denbury would employ BMPs during construction, with monitoring and prompt cleanup response, if required. Therefore, any potential impact from an inadvertent discharge would be temporary.

Site-specific biological surveys did not identify any federally or state-protected species (CH2M Hill 2011). The surveys did, however, identify suitable habitat for colonial wading birds on the pipeline corridor at Bayou d'Inde and around the Houston River. Great blue herons (*Ardea*

herodias), yellow-crowned night herons (*Nyctanassa violacea*), snowy egrets (*Egretta thula*), and white ibis (*Eudocimus albus*) were present at these locations.

Denbury consulted with the Louisiana Department of Wildlife and Fisheries (LDWF), the Louisiana Natural Heritage Program, and the USFWS regarding construction of the CO₂ pipeline. The Louisiana Natural Heritage Program indicated that only the bald eagle (*Haliaeetus leucocephalus*) was known to occur in Calcasieu Parish (CH2M Hill 2011). The USFWS stated that no records of species federally listed as threatened or endangered or critical habitats were known to occur within 1 mile of the proposed CO₂ pipeline corridor (CH2M Hill 2011). The USFWS noted that bald eagles, which are protected under the Bald and Golden Eagle Protection Act, nest in southern Louisiana from October through mid-May. The USFWS also noted that the pipeline would be located in an area where colonial wading birds could be present and recommended that a qualified biologist inspect the work areas for the presence of undocumented nesting colonies during the nesting season. The LDWF recommended that surveys of suitable nesting areas be conducted no more than two weeks before construction begins to determine whether breeding colonies are present. In addition, the USFWS recommended informing on-site personnel of the need to identify colonial wading birds and their nests, and avoid affecting them during the breeding season. USFWS also noted that clearing of forested habitat may result in direct, indirect, and cumulative impacts on migratory birds. Additional consultation would be necessary if nesting colonies are identified within 400 meters of construction work areas. The biological surveys conducted by CH2M Hill identified potential and confirmed colonial water bird nesting area locations east of the CO₂ pipeline corridor (CH2M Hill 2011).

The LDWF indicated that the Old Prairie crawfish (*Fallicambarus macneesei*) also may occur in the pipeline area. This species is listed as endangered in the State of Louisiana due to a restricted home range, development, and the oil industry. It occurs in wet meadow habitats, including ditches flooded by heavy rains, or in complex burrows carved in the sandy-clay soils of roadside ditches. The presence of the Old Prairie crawfish was confirmed in a developed area west of the project corridor (CH2M Hill 2011). Project surveys identified emergent wetland habitat, which can be considered habitat for the Old Prairie crawfish, within the project corridor at multiple locations. However, no burrows were identified, and there were no other indications that the Old Prairie crawfish occurred within the pipeline construction workspace.

Denbury sited the CO₂ pipeline maximizing the use of existing ROWs to minimize impacts to biological resources. Denbury would obtain necessary permits and implement associated BMPs in compliance with federal and state permits to further minimize potential impacts. Denbury would conduct site-specific surveys of suitable nesting areas no more than two weeks before construction begins to determine whether nesting by migratory birds or colonial waterbirds is present. In addition, Denbury would implement awareness training for on-site personnel to migratory bird issues and identify colonial wading birds and their nests, and avoid affecting them during the breeding season. With the proposed design and compliance with applicable permits, construction of the CO₂ pipeline would have minor impacts to biological resources.

Operation

Long-term maintenance of the pipeline would involve routine mowing to prevent forested species from becoming reestablished. If ROW maintenance occurs during the breeding season, minor impact on local resident wildlife population could occur. Minor impact could be from noise and dislocation. However, the impact would be temporary and minor since resident

terrestrial species have the ability to relocate. It is unlikely any migratory bird species would utilize a routinely maintained ROW for nesting. Therefore, within the ROW routine maintenance performed could have temporary, negligible impacts on local wildlife populations from noise and human and vehicle movement. Maintained ROW would not provide suitable habitat for migratory bird species. Therefore, it is unlikely any impact to migratory birds would occur from maintenance operations along the pipeline corridor.

4.6.3.3 Alternative Route B

Construction of the pipeline along alternative route B would use the same construction methods to avoid or minimize impacts on terrestrial vegetation, wildlife, and aquatic ecology. Impacts resulting from construction would be similar to those discussed above. As described in Section 4.4.3.2.2, the proposed alternative route B would affect 5 additional minor water body crossings and 54.89 additional wetland acres. The alternative route would impact 26.29 acres of wetland habitat (versus 2.87 acres for the proposed route). Approximately 0.91 acres of forested and scrub-shrub wetlands would be permanently converted into emergent wetlands within the permanent ROW by the construction and operation of the pipeline, while 1.96 acres of forested wetlands would be cleared during construction but allowed to revegetate to forested wetlands following construction.

Four species listed as endangered or threatened by the USFWS are shown by the Louisiana Natural Heritage Program as potentially occurring in Calcasieu Parish, including the red-cockaded woodpecker (*Picoides borealis*, state and federally endangered); red wolf (*canus rufus*, federally endangered, assumed extirpated); bald eagle (*Haliaeetus leucocephalus*, state threatened); and the crested caracara (*Caracara cheriway*, federally threatened). The only species for which potential habitat exists in the area of the CO₂ pipeline is the crested caracara (*Caracara cheriway*). Ecological field surveys were not performed to verify the suitability of habitat and potential presence of Crested caracara. There are no known occurrences of federal or state protected aquatic species in the vicinity of the alternative Route B (CH2M Hill 2011).

Impacts on terrestrial vegetation and wildlife during operation, including T&E species and invasive species, would be the same as indicated in Section 4.6.2.2.2.

4.6.3.4 West Hastings Research MVA Program

Activities related to the reworking of existing wells would be confined to existing roads and well pads in the West Hastings oil field. The activities would involve the temporary use of truck-mounted equipment, which would result in no or negligible impacts on biological resources. No new or invasive species would be introduced to the area, and the populations of existing invasive species would not substantially expand.

The research MVA impacts on plant and animal species would be of a relatively short duration and small spatial extent. Larger and more mobile wildlife would be capable of avoiding direct mortality from well conversion or monitoring activities. Since the area was previously disturbed, no habitat fragmentation or changes in land use would occur. The plant and animal species found in this type of habitat are common and widespread and no rare species are expected to occur (APCI, 2011). Negligible impacts on aquatic ecology, terrestrial vegetation, or wildlife, including T&E species are expected as a result of the research MVA activities.

4.6.4 Summary of Impacts

Tables 4.6-3 and 4.6-4 present summaries of the biological resources impacts and minimization measures for the LCCE Gasification plant and the Lake Charles CCS project.

Table 4.6-3 Summary of Potential Impacts on Biological Resources and Minimization Measures for LCCE Gasification Plant and Off-site Activities

Potential Impacts	Minimization Measure(s)
<p>Construction: Minor Approximately 70 acres of previously disturbed, industrial developed, open space land would be impacted. Clearing of the equipment laydown area could remove 40 acres of potential forested habitat. The water supply pipeline corridor would impact 18.47 and 62.74 acres, respectively, of forest habitat potentially used by the red-cockaded woodpecker. Suitable habitat for colonial wading birds may be present along the pipeline route intersections with Bayou D’Inde and around the Houston River.</p>	<p>To obtain a permit to construct the equipment laydown area, Leucadia would perform a survey of biological resources, quantification of potential impacts, and mitigation, if applicable.</p> <p>Leucadia located pipelines along existing ROWs to the extent practicable. As design of pipeline corridors are finalized, Leucadia would perform site-specific surveys and mitigation, if applicable, in accordance with federal and state permitting requirements.</p> <p>Impacts to biological resources associated with wetland and waterbodies along the pipeline route would be temporary and avoided or minimized by use of the HDD construction method.</p>
<p>Operation: Negligible Long-term maintenance of the hydrogen pipeline, if it occurs during the breeding season, could cause temporary noise and dislocation of colonial wading birds and species, if present in adjacent forested habitats.</p>	<p>No minimization measures would be necessary.</p>

Table 4.6-4 Summary of Potential Impacts on Biological Resources and Minimization Measures for Lake Charles CCS Project

Potential Impacts	Minimization Measure(s)
<p>Construction and Operation of the CO₂ Capture and Compression Facilities: Minor Included in the LCCE Gasification plant (see Table 4.6-3)</p>	<p>Included in the LCCE Gasification plant (see Table 4.6-3).</p>
<p>Construction of the CO₂ Pipeline: Minor Pipeline construction would affect 10.21 acres of forest, 17.65 acres of scrub-shrub, and 2.1 acres of herbaceous grassland habitats. Biological surveys identified potential and confirmed colonial wading bird nesting area locations east of the CO₂ pipeline corridor.</p>	<p>Denbury located the pipeline along existing ROWs to the extent practicable. Denbury would obtain necessary federal and state permits, and associated site-specific surveys and mitigation, if necessary, prior to construction. During construction, Denbury would implement BMPs to minimize impacts to biological resources.</p>
<p>Construction of the Alternative Pipeline: Minor Construction would involve five additional waterbody crossings, and impact 26.29 acres of wetland habitat (versus 2.87 acres for the proposed route). Potential habitat exists for the Crested caracara (Caracara cheriway).</p>	<p>Denbury located the pipeline along existing ROWs to the extent practicable. Denbury would obtain necessary federal and state permits and implement associated BMPs to minimize impacts.</p>

Table 4.6-4 Summary of Potential Impacts on Biological Resources and Minimization Measures for Lake Charles CCS Project

Potential Impacts	Minimization Measure(s)
<p>Operation of the CO₂ Pipeline or Alternative Pipeline: Negligible Long-term maintenance of the pipeline, if it occurs during the breeding season, could cause temporary noise and dislocation of colonial wading birds and species, if present in adjacent forested habitats.</p>	<p>No minimization measures would be necessary.</p>
<p>Operation of the West Hastings research MVA program: Negligible Reworking of existing wells and use of existing roads would involve the temporary use of truck-mounted equipment, which would result in no or negligible impacts. Since the area was previously disturbed, no habitat fragmentation would occur. There are no rare species expected in this type of habitat.</p>	<p>No minimization measures would be necessary.</p>

4.7 Cultural Resources

4.7.1 Factors Considered for Assessing Impacts

DOE evaluated the potential impacts of the proposed action and its alternatives on cultural resources (including resources listed in, or determined eligible for listing in, the NRHP) that are within the APE for the proposed action. DOE assessed the potential for impacts on cultural resources based on whether the project would directly or indirectly:

- cause the potential for loss, isolation, or alteration of an archaeological resource eligible for NRHP listing;
- cause the potential for loss, isolation, or alteration of the character of a historic site or structure eligible for NRHP listing, or introduce visual, audible, or atmospheric elements that would adversely affect a historic resource eligible for NRHP listing;
- cause the potential for loss, isolation, or alteration of resources that may be of cultural or religious significance to Native American tribes, including graves, remains, and funerary objects, or introduce visual, audible, or atmospheric elements that would adversely affect the resources; or
- cause the potential for loss, isolation, or alteration of a cemetery.

As part of the NEPA compliance process and in accordance with Section 106 of the NHPA, the DOE also evaluated the potential impacts of the proposed action and its alternatives to determine the effects of the project on historic properties (those resources that are listed in, or determined eligible for listing in, the NRHP). The effects determination made pursuant to Section 106 of the NHPA is based on the application of the criteria for adverse effects listed in 36 CFR 800.5(1) and (2) (see Table 4.7-1). The effects determination is presented in terms of whether such impacts would result in a finding of (1) no historic properties affected (also known as no effect

on historic properties); (2) no adverse effect on historic properties; or (3) adverse effect on historic properties (36 CFR 800.5(d):

- A finding of no historic properties affected (or no effect on historic properties) is generally made when no historic properties are located within the APE for the proposed action, or when a proposed action would have no effect on historic properties that are located within the APE.
- A finding of no adverse effect on historic properties is generally made when historic properties are located within the APE, and the proposed action would have an effect on those historic properties, but the effect would not be considered adverse based on the application of the criteria for adverse effects.
- A finding of adverse effect on historic properties is made when historic properties are located within the APE, the proposed action would have an effect on those historic properties, and the effect would be adverse based on the application of the criteria for adverse effects.

Table 4.7-1 Criteria for the Determination of Adverse Effects on Historic Properties

Criteria of Adverse Effect
An adverse effect is found when an undertaking may alter, directly or indirectly, any of the characteristics of a historic property that qualify the property for inclusion in the National Register in a manner that would diminish the integrity of the property's location, setting, materials, workmanship, feeling, or association. Consideration shall be given to all qualifying characteristics of a historic property, including those that may have been identified subsequent to the original evaluation of the property's eligibility for the National Register. Adverse effects may include reasonably foreseeable effects caused by the undertaking that may occur later in time, be farther removed in distance or cumulative (36 CFR 800.5[a][1]).
Examples of Adverse Effect
Adverse effects on historic properties include but are not limited to: <ul style="list-style-type: none"> ■ Physical destruction of or damage to all or part of the property; ■ Alteration of a property, including restoration, rehabilitation, repair, maintenance, stabilization, hazardous material remediation and provision of handicapped access, that is not consistent with the Secretary's Standards for the Treatment of Historic Properties (36 CFR Part 68) and applicable guidelines; ■ Removal of the property from its historic location; ■ Change of the character of the property's use or of physical features within the property's setting that contribute to its historic significance; ■ Introduction of visual, atmospheric, or audible elements that diminish the integrity of the property's significant historic features; ■ Neglect of a property which causes its deterioration, except where such neglect and deterioration are recognized qualities of a property of religious and cultural significance to an Native American tribe or Native Hawaiian organization; ■ Transfer, lease, or sale of property out of federal ownership or control without adequate and legally enforceable restrictions or conditions to ensure long-term preservation of the property's historic significance (36 CFR 800.5[a][2]).

Source: ACHP 2004.

4.7.2 LCCE Gasification (Connected Action)

4.7.2.1 Construction

Construction of the gasification plant would disturb a portion of one cultural resource that is located within the APE. This direct, negative impact would result from the destruction of the portion of archaeological site 16CU29 that is within the APE during ground disturbance associated with clearing, site preparation, and building activities. As discussed above in Section 3.7.1, the Louisiana SHPO has previously concurred with the determination that Site 16CU29 was not NRHP-eligible and that no further investigations were necessary (Hutcheson 2009). Therefore, construction would have a minor impact on cultural resources.

Construction of the parking area for construction vehicles and the linears for natural gas, potable water, transmission, sulfuric acid and methanol pipelines; the raw water pipeline; and the hydrogen pipeline would have no impacts on any previously identified or recorded cultural resource because none have been identified within the APE. When the area to be used for equipment laydown and methanol/sulfuric acid storage has been finalized, the location will be assessed for potential impacts on cultural resources.

4.7.2.2 Operation

Operation of the gasification plant would have no impacts on cultural resources or historic properties. The construction parking area would not be used for operational activities. Therefore, no impacts on cultural resources would occur from use of the construction parking area. Operation of the natural gas, potable water, transmission, sulfuric acid and methanol pipelines, and operation of the raw water and hydrogen pipelines would have no impacts on any previously identified or recorded cultural resource because none have been identified within the APE.

4.7.3 Lake Charles CCS Project

4.7.3.1 CO₂ Capture and Compression Facilities

The impacts that would result from construction and operation of the CO₂ capture and compression facilities would be the same as those for the LCCE Gasification plant (see Section 4.7.2.1 and 4.7.2.2).

4.7.3.2 CO₂ Pipeline

4.7.3.2.1 Proposed Route

Construction

Construction of the CO₂ pipeline would result in direct, permanent negative impacts on one cultural resource, archaeological site 16CU73 identified within the APE. These impacts would result from destruction of the site during ground disturbance associated with clearing, site preparation, and building activities.

Construction of the CO₂ pipeline also has the potential to result in direct, permanent, negative impacts on the Hardey Family Cemetery. Direct, permanent, negative impacts may occur during ground disturbance associated with clearing, site preparation, and building activities. Denbury proposes to avoid the direct impacts by directionally drilling beneath the cemetery to avoid physical disturbance of the two interments (Watkins and Futato 2011). It is possible that directional drilling beneath the Hardey Family Cemetery may result in indirect, permanent, negative impacts on the cemetery because the presence of the buried pipeline could alter the

setting of the cemetery. However, cemetery owners have indicated no objection to construction of the proposed pipeline if there are no surface operations and if the proposed pipeline is bored and installed below the Hardey Family cemetery using a HDD method at a depth of at least 25 feet below the surface of the cemetery (Hardey and Hardey 2012). Therefore, construction would have a minor impact on cultural resources associated with the CO₂ pipeline.

Operation

Operation of the CO₂ pipeline would have no impacts on cultural resources or historic properties that are archaeological resources. The single archaeological resource identified within the APE, Site 16CU73, would no longer be present because construction activities would destroy it.

Operation of the CO₂ pipeline may result in indirect, permanent, negative impacts on the Hardey Family Cemetery if the CO₂ pipeline is installed beneath the cemetery using directional drilling. Rerouting the CO₂ Pipeline around the cemetery would avoid indirect permanent, negative impacts on the Hardey Family Cemetery. However, cemetery owners have indicated no objection to construction of the proposed pipeline if there are no surface operations and if the proposed pipeline is bored and installed below the Hardey Family cemetery using HDD method at a depth of at least 25 feet below the surface of the cemetery (Hardey and Hardey 2012). The presence of the buried pipeline may alter the setting of the cemetery. Therefore, construction would have a minor impact on cultural resources associated with the CO₂ pipeline.

4.7.3.2.2 Alternative Route B

Construction

If alternative route B is selected as the preferred alignment for the CO₂ pipeline, Denbury would conduct cultural resources investigations to identify cultural resources and historic properties within the APE for alternative route B. The evaluation of impacts resulting from construction of the pipeline along alternative route B on cultural resources pursuant to NEPA would be based on the results of these cultural resources investigations.

Operation

Pursuant to NEPA, Denbury would evaluate the impacts on cultural resources resulting from operation of the pipeline along alternative route B based on the results of cultural resources investigations performed by Denbury prior to construction.

4.7.3.3 West Hastings Research MVA

Operation of the West Hastings research MVA program would have no impacts on cultural resources because none were identified within the MVA area. There are no historic properties as defined by the NHPA identified on the Texas Archeological Site Atlas or the National Register of Historic Places within one mile of the Hastings research area components in Brazoria County (APCI 2011).

4.7.4 Compliance with Section 106 of the NHPA

This section summarizes the DOE's compliance with Section 106 of the NHPA.

4.7.4.1 Definition of Area of Potential Effects

The APE for an undertaking is defined as the geographic area or areas within which the proposed action may directly or indirectly cause alterations in the character or use of historic properties, if

such properties exist (36 CFR 800.16(d)). For the purposes of compliance with Section 106 of the NHPA, the DOE defined the APE as all the areas that are included within the boundaries of the proposed action. The APE in Louisiana (specifically in Calcasieu Parish) includes the following proposed project facility locations: the Lake Charles CCS project locations (including the carbon capture and compression location and the CO₂ pipeline route); and the LCCE Gasification plant location (including the gasification plant facilities property and the off-site facility locations for the raw water supply, potable water supply, hydrogen, natural gas, methanol, and sulfuric acid pipelines; the electric transmission line; the construction parking area; and the as yet undetermined locations for the equipment laydown area and the methanol and sulfuric acid storage area (see Figure 2.3-4). The APE in Texas (specifically in Brazoria County) consists of the MVA area, including the injection sites (see Figure 2.3-6).

4.7.4.2 Section 106 Consultation

The DOE consulted with the Louisiana and Texas State Historic Preservation Officers (SHPOs), 13 federally recognized Native American tribes, seven other potential interested parties, and the ACHP (see Appendix D). The sections below summarize the results of Section 106 consultations.

4.7.4.2.1 State Historic Preservation Officers (SHPOs)

Section 106 consultation for the proposed action was initiated by the DOE with the Louisiana and Texas SHPOs in accordance with 36 CFR Part 800 on August 15, 2012 (see Appendix D). The purpose of this consultation was to introduce the proposed action to the SHPOs, to obtain concurrence on the APE for the proposed action, to concur with additional parties that would be consulted with as part of the Section 106 process, and to identify any issues or concerns regarding the identification of cultural resources or historic properties that may be located within the APE (Fayish 2012a, 2012b). As part of the initiation of consultation, DOE also submitted the following two reports for the off-site activities associated with the LCCE Gasification plant for the Louisiana SHPO's review and comment: the Phase IA cultural resources survey report for the linears for the raw water and hydrogen pipelines and the construction parking area (Handly 2012) and the Phase IA cultural resources desktop assessment for the potable water, natural gas, methanol, and sulfuric acid pipelines and the electric transmission line (URS 2012). The Louisiana SHPO reviewed the information provided, concurred with the definition of the APE for the proposed action and concurred with recommendations for the off-site activities associated with the LCCE Gasification plant. For remaining areas, the Louisiana SHPO agreed that the field methodology outlined in the report is an appropriate measure to identify any potential historic properties; agreed with the high probability areas determination and that those areas should be surveyed as such; indicated that all remaining areas should be tested according to the Louisiana SHPO's low probability standards; and agreed to review the report upon completion of fieldwork (Breux 2013).

DOE has noted that, as part of an air permit application, Lake Charles Cogeneration, LLC, previously consulted with the Louisiana SHPO regarding the presence of cultural resources on the property where the carbon capture and compression facility (a component of the Lake Charles CCS project) and the gasification plant (a component of the LCCE Gasification plant) are located (Maley 2008). This consultation, which was not conducted pursuant to Section 106 of the NHPA or its implementing regulations at 36 CFR Part 800, identified the boundaries of the gasification plant property (which is within the APE for the current proposed action), and requested the identification of any known archaeological sites or historic structures located

within 1,000 feet of the property that are listed in, or determined eligible for listing in, the NRHP.

The Louisiana SHPO's response to Lake Charles Cogeneration, LLC, indicated that one known archaeological resource, Site 16CU29, was located within the Lake Charles gasification facility property and requested a Phase I survey be conducted (Hutcheson 2008). URS Corporation conducted a field assessment of Site 16CU29 on behalf of Lake Charles Cogeneration, LLC, in 2009 and concluded that Site 16CU29 was not eligible for listing in the NRHP and that no further archaeological investigations were warranted (Handly 2009). The Louisiana SHPO concurred with these findings (Hutcheson 2009). Section 3.7.2.2 discusses the results and conclusions of the cultural resources investigations for the LCCE Gasification plant site.

DOE has noted that Denbury previously consulted with the Louisiana SHPO regarding the results of the Phase I cultural resources survey for the proposed CO₂ pipeline (a component of the Lake Charles CCS project). This consultation, which was not conducted pursuant to Section 106 of the NHPA or its implementing regulations at 36 CFR Part 800, consisted of the submittal of the Phase I cultural resources survey report to the Louisiana SHPO for review and comment. The Phase I cultural resources survey report identified the location of the CO₂ pipeline (which is within the APE for the current proposed action) and presented the results of a Phase I cultural resources survey to identify archaeological and architectural resources. Two cultural resources were identified at the proposed CO₂ pipeline location: one historic archaeological site (16CU73) and one modern cemetery (the late 20th century Hardey Cemetery). Both cultural resources were recommended as not eligible for inclusion in the NRHP, and directional drilling was recommended to avoid impacts on the Hardey Cemetery during pipeline construction (Watkins and Futato 2011). Section 3.7.2 discusses the results and conclusions of the cultural resources investigations for the CO₂ pipeline in detail.

The Louisiana SHPO provided the following comments on the results of Watkins and Futato's 2011 Phase I cultural resources survey: (1) a request for preparation of a site form for the Hardey Cemetery, as recent legislative acts have given the Louisiana SHPO regulatory responsibility for many cemeteries and the SHPO is making an effort to record all cemeteries that are encountered during project investigations; (2) concurrence that archaeological site 16CU73 is not NRHP-eligible; and (3) concurrence that if the pipeline is directionally drilled under the Hardey Cemetery, no historic properties would be impacted by the project and no further work is necessary (Breux 2012).

DOE has noted that Denbury Onshore, LLC's consultant, William Self Associates, Inc. (WSA), previously consulted with the Texas Historical Commission (THC) on the West Hastings research MVA area (Karbula 2011). This consultation, which was conducted consistent with Section 106 of the NHPA and its implementing regulations at 36 CFR Part 800, identified the boundaries of the research MVA property (which is within the APE for the current proposed action); presented the results of a records and literature search for previously recorded cultural resources and historic properties and previously conducted surveys within the MVA property; and requested concurrence on the determination that the MVA area has a low probability for containing NRHP-eligible historic properties and that no archeological survey of the MVA areas is needed for the proposed action. Section 3.7.2.2 discusses the results and conclusions of the records and literature search for the MVA area in detail.

The Texas SHPO’s response to WSA indicated that they concur that the MVA area has a very low probability for containing NRHP-eligible properties and/or for formal designation as a State Archaeological Landmark. The Texas SHPO indicated the West Hastings research MVA may proceed without consultation with the Texas SHPO, provided development activities within the MVA do not encounter significant archaeological deposits (Wolfe 2011).

As noted above, the DOE initiated Section 106 consultation with the Texas SHPO for the West Hastings MVA Research area on August 15, 2012 (Fayish 2012b). On September 7, 2012, the Texas SHPO indicated that no historic properties would be affected (Wolfe 2012).

4.7.4.2.2 Federally Recognized Native American Tribes

In accordance with 36 CFR Part 800, on August 16, 2012, DOE initiated Section 106 consultation with 13 federally recognized Native American tribes in Louisiana, Texas, and other states that, for ancestral or historical reasons, may have an interest in the locations of the proposed action (see Table 4.7-2 and Appendix D). The purpose of this consultation was to introduce the proposed action to the tribes, determine whether the tribes were interested in participating in the consultation process as Section 106 consulting parties, and identify any issues or concerns regarding cultural resources of interest to the tribes, including, but not limited to, archaeological resources, properties of traditional religious or cultural importance, or traditional cultural properties (TCP)s. DOE consulted with federally recognized Native American tribes consistent with DOE 1230.2, *American Indian Tribal Government Policy*; AIRFA; EO 13007 *Indian Sacred Sites*; and EO 13175 *Consultation and Coordination with Indian Tribal Governments*. To date, the Choctaw tribe responded to the Section 106 consultation letter for the proposed action with a request for copies of the reports prepared and a project status.

Table 4.7-2 Federally Recognized Native American Tribes Consulted for the Proposed Action

Tribe	Section 106 Consultation for proposed action	Response Summary
Alabama Coushatta Tribe of Texas	August 16, 2012	No response to date
Caddo Nation	August 16, 2012	No response to date
Chitimacha Tribe of Louisiana	August 16, 2012	No response to date
Choctaw Nation of Oklahoma	August 16, 2012	Requested reports; requested additional information for site 16CU29
Coushatta Tribe of Louisiana	August 16, 2012	No response to date
Jena Band of Choctaw Indians	August 16, 2012	No response to date
Alabama Coushatta Tribe of Texas	August 16, 2012	No response to date
Mississippi Band of Choctaw Indians	August 16, 2012	No response to date
Quapaw Tribe of Oklahoma	August 16, 2012	No response to date
Seminole Nation of Oklahoma	August 16, 2012	No response to date
Seminole Tribe of Florida	August 16, 2012	No response to date
Tunica-Biloxi Tribe of Louisiana	August 16, 2012	No response to date
Ysleta Del Sur Pueblo of Texas	August 16, 2012	No response to date

4.7.4.2.3 Other Consulting Parties

In accordance with 36 CFR Part 800, on August 17, 2012, DOE initiated Section 106 consultation with seven other consulting parties or parties that may have a potential interest in the proposed action (see Appendix D). These parties included: Calcasieu Parish Police Jury,

Calcasieu Historical Preservation Society, Imperial Calcasieu Museum, the Archives Department of McNeese State University Library, Brazoria County Engineering Department, Brazoria County Historical Commissioner, and Brazoria County Historical Museum. To date, none of these consulting parties have responded to the Section 106 consultation letter for the proposed action.

4.7.4.2.4 Advisory Council on Historic Preservation (ACHP)

In accordance with 36 CFR Part 800, Section 106 consultation will be initiated by DOE with the ACHP. The purpose of this consultation will be to inform the ACHP of the proposed action and its effect on historic properties and provide the ACHP with the results of consultations with the SHPOs, federally recognized Native American tribes, and other consulting parties.

4.7.5 Summary of Impacts

Tables 4.7-3 and 4.7-4 present summaries of the cultural resources impacts and minimization measures for the LCCE Gasification plant and the Lake Charles CCS project.

Table 4.7-3 Summary of Potential Impacts on Cultural Resources and Minimization Measures for LCCE Gasification Plant and Off-site Activities

Potential Impacts	Minimization Measure(s)
<p>Construction: Minor Destruction of the portion of archaeological site 16CU29 that is within the APE during ground disturbance associated with clearing, site preparation, and building activities. The Louisiana SHPO has previously concurred with the determination that this site was not NRHP-eligible and that no further investigations were necessary.</p>	No minimization measures would be necessary.
<p>Operation: None</p>	

Table 4.7-4 Summary of Potential Impacts on Cultural Resources and Minimization Measures for Lake Charles CCS Project

Potential Impacts	Minimization Measure(s)
<p>Construction and Operation of the CO₂ Capture and Compression Facilities: Minor Included in the LCCE Gasification plant (see Table 4.7-3)</p>	Included in the LCCE Gasification plant (see Table 4.7-3)
<p>Construction of the CO₂ Pipeline: Minor Archaeological site 16CU73 would be destroyed.</p> <p>The Hardey Family Cemetery may be impacted, but cemetery owners have indicated no objection if there are no surface operations and directional drilling is used beneath the cemetery, at a minimum depth of 25 feet below the surface.</p>	No minimization measures would be necessary

Table 4.7-4 Summary of Potential Impacts on Cultural Resources and Minimization Measures for Lake Charles CCS Project

Potential Impacts	Minimization Measure(s)
<p>Construction of the Alternative Pipeline: Not applicable No CR surveys have been done for the alternative pipeline route. If alternative route B is selected as the preferred alignment for the CO₂ pipeline, Denbury would conduct cultural resources investigations.</p>	<p>Not applicable at this time.</p>
<p>Operation of the CO₂ Pipeline: Minor The presence of the buried pipeline may alter the setting of the cemetery. Cemetery owners have indicated no objection.</p>	<p>No minimization measures would be necessary.</p>
<p>Operation of the West Hastings research MVA program: None There are no historic properties within 1 mile of the Hastings research area.</p>	<p>Not applicable.</p>

4.8 Land Use

4.8.1 Factors Considered for Assessing Impacts

The potential effects of the construction and operation activities were evaluated to determine consistency with existing and future land use and zoning, and whether these activities would be compatible with surrounding land uses. Potential land use impacts include alterations to the current land use or zoning. DOE assessed the potential for impacts on land use based on whether the proposed project or connected action would:

- conflict with land uses within the subject properties,
- conflict with land uses within the adjacent properties, or
- result in land use restrictions on adjacent properties.

To assess impacts, local and state land use plans and zoning regulations were reviewed. Proposed land uses were compared with existing land uses for short-term and long-term compatibility.

4.8.2 LCCE Gasification (Connected Action)

4.8.2.1 Construction

4.8.2.1.1 Gasification Plant

Construction of the LCCE Gasification plant would not conflict with current and future land use plans and/or zoning ordinances of Calcasieu Parish. As noted in Section 3.8.1, the site is zoned for heavy industrial use. Construction would have temporary impacts on the surrounding properties. A residential zoned area is located southeast of the site across the Calcasieu River, and several residences are located approximately 0.75 miles north of the site. Surrounding residents and businesses may experience temporary traffic congestion and increased noise and dust levels. However, impacts on residences would be negligible due to the distance between the residential areas and the construction site. Analyses of dust and noise impacts are presented in

Sections 4.2 (Climate and Air Quality) and 4.11 (Noise). Construction activities would not restrict land use on adjacent properties or displace any residents or businesses.

4.8.2.1.2 Off-Site Activities

Construction of the parking area would result in the permanent conversion of the existing vegetative land cover to a gravel-covered area. The construction parking area would be within an existing industrial use area and no special land uses would be affected. Construction would not conflict with current or future land use plans and/or zoning ordinances of Calcasieu Parish. Construction would have temporary impacts on surrounding properties. Residential development is located directly east of the construction parking area. Surrounding residents and businesses may experience temporary traffic congestion and increased noise and dust levels.

Leucadia would determine the exact location of the equipment laydown area and methanol/sulfuric acid storage area as design progresses. Land use within 1 mile of the site is predominantly wetlands and developed areas, including heavy industrial and petrochemical development, as shown on Figure 3.8-1-A. Therefore, development of approximately 40 acres for the equipment laydown and methanol/sulfuric acid storage area would likely be consistent with the heavy industrial zoning classification of the area.

Permanent land disturbance would result from the excavation of pipeline trenches and clearing and grading within the construction ROW for the natural gas, potable water, electric transmission, sulfuric acid, and methanol linears. The use of temporary staging areas and access routes to the linears would have short-term impacts on land use. The linears would be located along existing utility ROWs, reducing impacts on surrounding land uses and properties. Construction would not impact special land uses such as recreation areas, public lands, historical sites, and protected waterbodies. Surrounding residents and businesses may experience temporary traffic congestion and increased noise and dust levels. However, impacts on residences would be negligible because the linears would be located in existing industrial utility corridors on properties zoned for heavy industrial use and would be located a minimum of 1 mile from the nearest residential area. Given that Leucadia would construct the linears in existing utility ROWs in an area zoned for heavy industrial uses, construction of the linears would avoid the development of new utility ROWs and would result in negligible impacts on surrounding properties.

For the water supply and hydrogen pipelines, permanent land disturbance would result from the excavation of pipeline trenches, clearing and grading, and construction of the metering and valve facilities within the construction ROW. Short-term impacts on land use would result from the use of temporary staging areas, warehouse yards, and access routes to the pipelines. The water supply pipeline would require a 50 to 250 foot-wide construction ROW and a 50 foot-wide permanent ROW. The width of the construction ROW would vary based on the width of existing ROW along the route and the need to accommodate waterbody or roadway crossings. The remaining ROW would share a common ROW corridor with two newly installed pipelines. Construction of the raw water pipeline would impact a total of 122 acres of land, including 24 acres of permanent ROW and 98 acres of temporary ROW. The hydrogen pipeline would require a 50 to 250 foot-wide construction ROW and a 75 foot-wide permanent ROW. Additional temporary workspaces would be required at road, railroad, pipeline, and waterbody crossings, and at equipment turnaround areas. Construction of the hydrogen pipeline (excluding additional temporary workspace and contractor work sites not within the ROW) would impact a

total of 77 acres of land, including 51 acres of permanent ROW and approximately 26 acres of temporary ROW.

DOE estimated the total potential acres of permanent and temporary impacts on land cover based on the expected ROW widths, as summarized in Tables 4.8-1 and 4.8-2.

Table 4.8-1 Land Cover/Land Use Impacts Associated with the Water Supply Pipeline Route

Land Cover/Land Use	Temporary Impacts (acres)	Permanent Impacts (acres)
Open water	1.55	0.82
Developed, open space	0.96	0.53
Developed, low intensity	12.81	6.28
Developed, medium intensity	10.82	5.66
Developed, high intensity	1.49	0.76
Evergreen forest	3.35	2.14
Mixed forest	0.00	0.00
Shrub/scrub	0.00	0.00
Grassland/herbaceous	0.00	0.00
Pasture/hay	0.00	0.00
Cultivated crops	0.00	0.00
Woody wetlands	12.76	6.81
Emergent herbaceous wetlands	2.36	1.23
Total	46.10	24.23

Table 4.8-2 Land Cover/Land Use Impacts Associated with the Hydrogen Pipeline Route

Land Cover/Land Use	Temporary Impacts (acres)	Permanent Impacts (acres)
Open water	0.38	0.15
Developed, open space	10.24	5.66
Developed, low intensity	45.49	24.13
Developed, medium intensity	7.13	3.74
Developed, high intensity	1.83	0.90
Evergreen forest	9.17	4.46
Mixed forest	0.46	0.23
Shrub/scrub	17.63	9.31
Grassland/herbaceous	2.48	1.38
Pasture/hay	2.88	1.52
Cultivated crops	0.00	0.00
Woody wetlands	26.06	13.42
Emergent herbaceous wetlands	4.06	2.17
Total	127.81	67.24

Leucadia co-located the raw water supply and hydrogen pipelines along existing ROW corridors to the extent practicable to reduce impacts on surrounding land uses and properties.

Approximately 76% of the water supply pipeline route and 99% of the hydrogen pipeline route follow existing ROWs. Construction would temporarily impact existing residences in close proximity to the proposed pipeline routes. Temporary impacts may include disruption of lawns; removal of fences, and accessory structures; removal of ornamental shrubs; loss of shade trees;

cutting of streets, driveways, and sidewalks; disruption of household utilities; altered traffic patterns; and noise, dust, and general annoyance associated with construction activities. Temporary visual impacts would result due to construction and ground disturbance. Impacts on cropland would be temporary, and active cropland would revert to pre-construction use for the full width of the ROWs. Construction would not impact special land uses such as recreation areas, public lands, historical sites, and protected waterbodies.

Leucadia would implement pipeline construction BMPs as measures to minimize impacts on land use during construction. Depending on location-specific restrictions, available space, or regulatory constraints that may exist, these measures would include the following:

- Use specialized construction methods, such as stovepipe and drag-section construction.
- Notify homeowners or business owners in advance of construction activities and any scheduled disruptions of utilities.
- Provide alternative ingress and egress, to the extent practicable, for properties impacted during construction.
- Restore sidewalks, driveways, roads, fences, and other structures removed during construction as soon as practicable.
- Maintain mature trees and landscaping within the construction work areas unless the trees and landscaping interfere with installation techniques or present unsafe working conditions.
- Develop irrigation crossing standards in actively cultivated agricultural areas and repair damages to irrigation pipelines or drain tiles within the construction ROW to the landowner specifications or to preconstruction conditions.
- Perform wetland mitigation as required by applicable permits.

The permanent ROWs would be maintained with vegetation, and land use within the permanent pipeline easements would be restricted. Maintenance of the 50 foot-wide permanent ROWs would prevent the growth of trees and bushes. As Leucadia finalizes the design of the pipeline corridors and applies for required regulatory approvals for potential impacts, some variations in the routes may occur. Leucadia would avoid or minimize potential impacts by locating pipelines along existing ROWs to the maximum extent practicable. Construction of the raw water supply and hydrogen pipelines would have temporary and minor impacts on existing uses of adjacent land.

4.8.2.2 Operations

4.8.2.2.1 Gasification Plant

Operation of the LCCE Gasification plant would be consistent with current land use plans and zoning ordinances of Calcasieu Parish. The facility would be located within an existing industrial site, and the proposed LCCE Gasification plant would be visually compatible with the existing industrial landscape surrounding the site. Several of the surrounding businesses are industrial process facilities with similar operating methods. Operation of the LCCE Gasification

plant would be compatible with the surrounding industrial use properties and would have no or negligible impacts on surrounding land uses.

4.8.2.2.2 Off-Site Activities

Leucadia would determine the exact location of methanol/sulfuric acid storage area as design progresses. As described previously, the construction equipment laydown area would be converted to the methanol and sulfuric acid storage area during operation. Use of approximately 40 acres for the methanol and sulfuric acid storage area during operation is expected to be consistent with the heavy industrial zoning classification in the area.

Occasional short-term maintenance of the utility linears would require access to ROWs and, in some cases, the buried portions of the linears. Leucadia would coordinate with property owners or the owners of the existing ROW before performing maintenance and would use the appropriate pipeline construction measures described above to avoid or minimize impacts on adjacent land uses.

Occasional maintenance may require access to buried portions of the waters supply and hydrogen pipelines. Leucadia would coordinate with property owners to minimize potential disturbances to ongoing operations from maintenance access to the pipeline ROW. Leucadia would use pipeline construction measures described above to avoid or minimize impacts on adjacent land uses. Leucadia would revegetate the ROW and adjacent properties to pre-construction conditions to the extent practicable and mow and maintain the pipeline ROW, as necessary. Pigging stations would be temporarily installed at each end of the pipelines to clean and dry the pipelines and to perform pipeline integrity verification.

Operation of the off-site activities associated with LCCE Gasification plant would be compatible with the surrounding industrial use properties and would have negligible impact on surrounding land uses.

4.8.3 Lake Charles CCS Project

4.8.3.1 CO₂ Capture and Compression Facilities

Construction and operation of the CO₂ Capture and Compression Facilities would occur within the proposed LCCE Gasification plant site. Construction of the CO₂ Capture and Compression facilities would not use or disturb additional land. Construction impacts and minimization measures would be the same as those discussed for the LCCE Gasification plant. Construction and operation of the CO₂ Capture and Compression Facilities would result in a negligible land use impact.

4.8.3.2 CO₂ Pipeline

4.8.3.2.1 Proposed Route

Construction

Permanent land disturbance would result from excavation of pipeline trenches, clearing and grading, and construction of the metering and valve facilities within the construction ROW. Short-term impacts on land use would result from the use of temporary staging areas, warehouse yards, and access routes to the pipeline. The pipeline would require a 95 foot-wide construction ROW with additional temporary workspaces at road, railroad, pipeline, and waterbody crossings, and at equipment turnaround areas. Construction activities for the

proposed pipeline would include use of the 12.4 acre site for the warehouse yard and the 6.9-acre site for the pipe storage yard, also shown on Figure 2.3-4. Following construction, the pipeline construction ROW, storage yards, and additional temporary workspaces would be re-graded and restored to previous conditions and uses.

Construction of the pipeline (excluding additional temporary workspaces and contractor work sites not within the ROW) would cause short term impacts to 50.62 acres of temporary ROW and long term impacts to 56.34 acres of permanent ROW. Following construction, approximately 50.62 acres of land within the temporary ROW would be restored to previous conditions and uses. Table 4.8-3 summarizes the total acres of permanent and temporary impacts on land cover and land use. Construction of the CO₂ pipeline would result in the permanent conversion of 8.27 acres of forested land, including 2.98 acres of forested wetland (CH2M HILL 2011b). Small areas of other land cover (i.e., scrub/shrub, pasture, and herbaceous grassland) within the construction ROW could potentially be permanently impacted. No special land uses such as recreation areas, public lands, historical sites, or protected waterbodies would be impacted by construction activities. Impacts would be temporary, and active cropland would be allowed to revert to preconstruction use for the full width of the ROW.

Table 4.8-3 Land Cover/Land Use Impacts Associated with the Proposed CO₂ Pipeline Route

Land Cover/Land Use	Temporary Impacts (acres)	Permanent Impacts (acres)	Total Acres
Open water	0.27	0.24	0.51
Developed, open space	4.56	5.14	9.7
Developed, low intensity	22.08	25.12	47.2
Developed, medium intensity	3.63	4.03	7.66
Developed, high intensity	0.70	0.96	1.66
Evergreen forest	4.68	5.08	9.76
Mixed forest	0.24	0.21	0.45
Shrub/scrub	8.41	9.24	17.65
Grassland/herbaceous	0.94	1.16	2.1
Pasture/hay	1.25	1.38	2.63
Cultivated crops	0.00	0.00	0
Woody wetlands	2.98	2.80	5.78
Emergent herbaceous wetlands	0.88	0.98	1.86
Total	50.62	56.34	106.96

Use of the warehouse yard and pipe storage yard would have short-term, minimal impacts on land use. Both sites have previously been used for similar construction/industrial activities and land uses. The warehouse and pipe storage yards would be used on a temporary basis, and following construction would be restored as appropriate and in concurrence with landowner requests.

The CO₂ pipeline corridor would primarily border undeveloped land and areas of low-intensity development. Construction would temporarily impact existing residences in proximity to the pipeline corridor. Surrounding residents and businesses may experience temporary traffic congestion and increased noise and dust levels. Analyses of dust and noise impacts are presented in Sections 4.2 (Climate and Air Quality) and 4.11 (Noise). Temporary impacts may include disruption of lawns; removal of fences and accessory structures; removal of ornamental shrubs; loss of shade trees; cutting of streets, driveways, and sidewalks; altered traffic patterns; and

noise, dust, and general annoyance associated with construction activities. Temporary visual impacts would result due to construction and ground disturbance. Long-term impacts would result from the permanent conversion of land cover along the CO₂ pipeline ROW. Construction would eliminate forested areas within the permanent, 50-foot-wide ROW. Within the permanent ROW, no trees or bushes would be permitted. Where the pipeline ROW crosses private property, landowners would not be allowed to construct or place any structures (including houses, tool sheds, garages, guy wires, catch basins, swimming pools, trailers, leach fields, septic tanks, or any other objects not easily removable) within the permanent pipeline ROW.

Denbury would avoid or minimize adverse impacts on land use by locating the proposed CO₂ pipeline within or adjacent to existing utility ROWs with compatible land uses to the extent practicable. Denbury would implement pipeline construction BMP's and applicable regulatory requirements as mitigation measures to minimize impacts on land use during construction. Depending on location-specific restrictions, agreements with landowners, available space, or regulatory constraints that may exist, these minimization measures would include the following:

- Use specialized construction methods, such as stovepipe and drag-section construction.
- Notify homeowners or business owners in advance of construction activities and any scheduled disruptions of utilities.
- Provide alternative ingress and egress, to the extent practicable, for properties impacted during construction.
- Restore sidewalks, driveways, roads, fences, and other structures removed during construction as soon as practicable.
- Develop irrigation crossing standards in actively cultivated agricultural areas and repair damages to irrigation pipelines or drain tiles within the construction ROW to the landowner specifications or to preconstruction conditions.
- Perform wetland mitigation as required by applicable permits.

Final permits or landowner agreements may require changes or additional mitigation measures. Construction of the CO₂ pipeline would be compatible with existing uses of land along the proposed route for utility corridors and would result in a negligible impact on land use to accommodate the ROW for the proposed CO₂ pipeline.

Operation

Operation of the CO₂ pipeline would require that the ROW corridor remain clear of woody vegetation and development. Where the pipeline ROW crosses private property, operation of the CO₂ pipeline would require that landowners not construct or place any structures (including houses, tool sheds, garages, guy wires, catch basins, swimming pools, trailers, leach fields, septic tanks, or any other objects not easily removable) within the permanent pipeline ROW. Occasional maintenance may require access to buried portions of the pipeline. Denbury would use pipeline construction BMPs and minimization measures, described in the previous section, to avoid or minimize impacts on adjacent land uses and residences. The pipeline ROW would be revegetated to preconstruction conditions to the extent practicable and would be mowed and

maintained as necessary. Following maintenance activities that disturb property, Denbury would contact landowners to confirm that the conditions of all land agreements have been met. Operation of the pipeline would have temporary, negligible impacts on surrounding land uses during maintenance activities.

4.8.3.3 Alternative Route B

Construction of the CO₂ pipeline along the alternative route would utilize the same construction means to avoid or minimize impacts on land uses within the construction ROW and adjacent properties. Impacts resulting from construction along the alternative pipeline route would be similar to those discussed in Section 4.8.3.2.1. Construction along the alternative CO₂ pipeline route would impact a total of 187 acres of land, compared to 107 acres for the proposed route. Of this total, permanent impacts would occur on 72 acres, compared to 56 acres for the proposed route. Following construction, approximately 115 acres of land would be restored to previous conditions and uses (CH2M Hill 2010). Table 4.8-4 summarizes the total acres of permanent and temporary impacts on land cover and land use within the construction boundaries for the alternative route.

Table 4.8-4 Land Cover/Land Use Impacts Associated with the Alternate Pipeline Route

Land Cover/Land Use	Temporary Impacts (acres)	Permanent Impacts (acres)	Total Acres
Open water	0.01	0	0.01
Developed, open space	3.8	22.4	26.2
Developed, low intensity	20.7	25.6	46.3
Developed, medium intensity	3.3	3.6	6.9
Developed, high intensity	1	0.9	1.9
Evergreen forest	4.3	2.9	7.2
Mixed forest	0.8	1.3	2.1
Shrub/scrub	2.2	1.5	3.7
Grassland/herbaceous	0	0.2	0.2
Pasture/hay	9.8	29.9	39.7
Cultivated crops	0.7	1.6	2.3
Woody wetlands	25.6	25.1	50.7
Total	72.21	115.0	187.21

Operational impacts for the alternative CO₂ pipeline route would be the same as identified for the proposed pipeline route, resulting in no additional or different impacts.

4.8.3.4 West Hastings Research MVA

The research MVA activities would occur within unincorporated areas of Brazoria County, Texas and zoning and land use regulations are not applicable. The West Hastings research MVA activities are consistent with the existing commercial EOR operation land use and would have negligible impact on land use in the immediate or surrounding areas.

4.8.4 Summary of Impacts

Tables 4.8-5 and 4.8-6 present summaries of the land use impacts and minimization measures for the LCCE Gasification plant and the Lake Charles CCS project.

Table 4.8-5 Summary of Potential Impacts on Land Use and Minimization Measures for LCCE Gasification Plant and Off-site Activities

Potential Impacts	Minimization Measure(s)
<p>Construction: Minor The gasification plant would impact 70 acres of property zoned heavy industrial. The raw water pipeline would impact a total of 122 acres of land, including 24 acres of permanent ROW and 98 acres of temporary ROW. The hydrogen pipeline (excluding additional temporary workspace and contractor work sites not within the ROW) would impact a total of 77 acres of land, including 51 acres of permanent ROW and 26 acres of temporary ROW. Surrounding residents and businesses may experience temporary traffic congestion and increased noise and dust levels.</p>	<p>Leucadia would construct the linears in existing industrial utility corridors on properties zoned for heavy industrial use. The linears would be located a minimum of 1 mile from the nearest residential area.</p> <p>Leucadia would collocate approximately 76% of the raw water supply and 99% of the hydrogen pipelines along existing ROW corridors to reduce impacts on surrounding land uses and properties. Leucadia would revegetate the ROWs and adjacent properties to pre-construction conditions and maintain the ROWs.</p> <p>Leucadia would use BMPs including dust suppression techniques to control the dust generated by construction activities.</p>
<p>Operation: Negligible Occasional maintenance may require access to buried portions of the water supply and hydrogen pipelines.</p>	<p>Leucadia would coordinate with property owners to minimize disturbance to ongoing operations. Leucadia would revegetate the ROW and adjacent properties, if necessary.</p>

Table 4.8-6 Summary of Potential Impacts on Land Use and Minimization Measures for Lake Charles CCS Project

Potential Impacts	Minimization Measure(s)
<p>Construction and Operation of the CO₂ Capture and Compression Facilities: Minor Included in the LCCE Gasification plant (see Table 4.8-5)</p>	<p>Included in the LCCE Gasification plant (see Table 4.8-5)</p>
<p>Construction of the CO₂ Pipeline: Negligible Construction would cause short term impacts to 50.62 acres of temporary ROW, which would be restored to previous conditions and uses. There would be long-term impacts to 56.34 acres, including 8.27 acres of forested land with 2.98 acres of forested wetland.</p>	<p>Denbury would locate the proposed pipeline within or adjacent to existing utility ROWs with compatible land uses to the extent practicable. Denbury would implement pipeline construction BMPs and applicable regulatory requirements to minimize impacts on land use during construction.</p> <p>Following construction, Denbury would regrade and restore the pipeline construction ROW, storage yards, and ATWS to previous conditions and uses.</p>
<p>Construction of the Alternative Pipeline: Negligible Construction would cause short term impacts to 187 acres of land, including permanent impacts on 72 acres.</p>	<p>The same minimization measures would be used as described above.</p>

Table 4.8-6 Summary of Potential Impacts on Land Use and Minimization Measures for Lake Charles CCS Project

Potential Impacts	Minimization Measure(s)
<p>Operation of the CO₂ Pipeline or Alternative Pipeline : Negligible Operation of the CO₂ pipeline would require that the area remain clear of woody vegetation and development. Where the pipeline ROW crosses private property, operation of the CO₂ pipeline would restrict landowner uses within the permanent pipeline ROW. Occasional maintenance may require access to buried portions of the pipeline.</p>	<p>Denbury would implement pipeline construction BMPs and applicable regulatory requirements to minimize impacts on land use during construction.</p> <p>Following any construction activities during maintenance, Denbury would regrade and restore the pipeline construction ROW to previous conditions and uses.</p>
<p>Operation of the West Hastings research MVA program: Negligible The research MVA activities are consistent with the existing commercial EOR operation land use.</p>	<p>No minimization measures would be necessary.</p>

4.9 Socioeconomics and Environmental Justice

4.9.1 Factors Considered for Assessing Impacts

DOE evaluated the potential impacts of the proposed project and connected action on social and economic conditions and the potential effects on environmental justice communities. The analysis considered the following factors:

- generate a substantial increase in local/regional employment or income levels during either the construction or operations phases,
- result in supply of or demand for temporary or permanent housing in the region,
- result in permanent or temporary changes in the local population or demographic characteristics,
- generate an additional demand on community services that could not be accommodated with existing facilities,
- result in an increase in local government expenditures that would create a tax burden on local residents that would not be offset by additional revenues generated by the proposed action; or
- cause a significant and disproportionately high and adverse effect on minority or low-income populations.

This section evaluates the following resources: population and housing, economy and employment, local government services and fiscal impacts, community and public services, and environmental justice.

4.9.2 LCCE Gasification Plant (Connected Action)

As described previously, the LCCE Gasification plant includes the Gasification plant and off-site activities. Some off-site activities, such as the construction parking and equipment laydown area, involve only construction, whereas some activities, such as the utility linears, storage areas, and water pipeline, involve both construction and operation. The off-site activities are included in the evaluations below since Leucadia would complete the construction simultaneously and as a complete project.

4.9.2.1 Population and Housing Impacts

Construction

Construction of the proposed LCCE Gasification plant and Lake Charles CO₂ Capture and Compression facilities is not expected to result in a substantial migration of new residents to the Greater Lake Charles area. The construction phase of the project would require an average of 500 full-time equivalent (FTE) workers dedicated to construction at the site for approximately 36 months. An FTE worker is defined as one worker working eight hours per day for 260 days per year, or several workers working a total of 2,080 hours in a year. At peak construction, a maximum of 900 workers would be required on site at any given time. The average and maximum employment estimates equal, respectively, approximately 0.2% and 0.4% of the total population of Calcasieu Parish. Approximately 95% of the construction workers would be expected to be hired locally and are assumed to currently reside in Calcasieu Parish or would commute from other nearby population centers. The remaining 5% of the construction workers needed to complete this project would require specialized skills and are expected to be hired from outside the region. Therefore, it is estimated that a maximum of 45 transient workers from outside the region would temporarily relocate to Calcasieu Parish during construction of the proposed LCCE Gasification plant and CO₂ capture and compression facilities. Given the temporary nature of the construction work, it is assumed that these transient workers would not be accompanied by members of their households.

Therefore, at peak construction, the additional workers from outside the region would represent an in-migration of only 45 persons, or approximately 0.02% of the 2010 total population of Calcasieu Parish. Construction is expected to have only a minor, temporary impact on local population levels and is not expected to have any long-term impact on local population levels.

The construction phase is not expected to have an impact on the housing market in the Greater Lake Charles area. As described above, because of its short-term nature, the construction phase would not result in large-scale migration of new residents to the region and would not substantially impact the demand for housing in the region. The supply of housing would not be expected to be impacted by this project.

However, the addition of 45 transient workers would create a small, short-term increase in the demand for temporary housing, such as rental properties, hotel/motel rooms, and RV camp sites in local population centers. The increase in demand for temporary housing would temporarily reduce vacancy rates for such properties throughout the region and would provide short-term economic benefits to owners of temporary housing in the region. No existing residential housing units would be directly impacted by construction.

Operation

The migration of permanent workers into the Greater Lake Charles area is expected to occur as a result of the operational phase of the proposed LCCE Gasification plant and Lake Charles CO₂ Capture and Compression facilities. Leucadia estimates that the operational phase would require a total of 187 new permanent workers at the facility and approximately 90% of these additional workers would be hired from the existing local labor market. The remaining 10% of these new operational workers would require specialized skills and are expected to be hired from outside the region, resulting in the relocation of approximately 19 permanent workers to the area. All operational employees are assumed to be permanent residents and would relocate to the region with members of their households. Since the households of permanent operational employees are expected to be of similar size as households currently residing in Calcasieu Parish, each permanent worker is assumed to be accompanied by an average of 2.55 household members (U.S. Census 2010). Given this assumption, the 19 relocating workers are expected to increase the total population of the region by approximately 48 persons, or approximately 0.02% of the total population of Calcasieu Parish, during the operational phase of the proposed project.

Assuming that each additional permanent worker would require one permanent housing unit, an estimated 19 additional housing units would be required in the region during the operational phase of the proposed project. Given the availability of housing in the City of Sulphur and Calcasieu Parish described in Section 3.9.1.1, the region has more than enough housing units to accommodate new permanent workers. Therefore, the impact on the supply or price of permanent housing units in the City of Sulphur and Calcasieu Parish will be negligible. Operation is not expected to directly impact any existing residential units.

4.9.2.2 Economy and Income

Construction

Construction of the proposed LCCE Gasification plant and Lake Charles CO₂ Capture and Compression facilities is expected to have a positive, short-term impact on the economies of communities within the Greater Lake Charles area. The approximately \$2 billion (2010 dollars) project would inject substantial income into the regional economy. Approximately 30% of all materials needed to complete the plant and facilities are expected to be purchased in the local economy, and nearly 90% of all construction contracts are expected to be sourced out of the Greater Lake Charles area. As described above, construction of the proposed project is expected to temporarily increase employment in the region during the 36-month construction period and would require an average of 500 workers. During peak construction periods, this figure is expected to reach 900 workers, or 1.0% of the total civilian labor force in Calcasieu Parish.

In addition to the direct expenditures and employment impacts, the proposed project would also generate additional indirect and induced economic benefits from the increased economic activity. A portion of the wages paid to construction workers is anticipated to be spent locally, particularly since a large majority of these workers are expected to be recruited from the local labor force. Furthermore, increased revenues from material purchases and construction contracts would inject funds into the regional economy. As the overall demand for goods and services in the region increase, merchants may respond by increasing employment at their operations and/or purchasing more goods and services from their providers. These providers may then, in turn, increase employment in their establishments and/or spend a portion of their income in the region, thus “multiplying” the positive economic impacts of the original increase in construction

spending. These “multiplier” effects would continue on until all of the original funds have left the region’s economy through either taxes, savings, or through purchases from outside the region. Since construction expenditures are temporary in nature, the positive economic impacts would be short-term and would last only during the construction period.

Operation

Operation of the proposed LCCE Gasification plant and Lake Charles CO₂ Capture and Compression facilities is expected to have a positive, long-term impact on the economies of communities within the Greater Lake Charles area. As described above, the operation of the proposed project is expected to increase permanent employment at the facility by 187 permanent workers, or approximately 0.2% of the total civilian labor force in Calcasieu Parish. Annual payroll for operational workers is expected to be approximately \$16 million. Furthermore, the proposed project is expected to incur \$54.5 million in annual operational costs, with approximately \$21.8 million of this total being used to procure local goods and services. This injection of \$36.8 million each year into the regional economy for payroll and other operations and maintenance costs would have direct positive economic impacts on the regional economy. Because these costs would recur annually, the positive economic impacts associated with the operation of the plant and capture and compression facilities would occur as long as the activity at the facilities continues.

As described previously for the construction phase of the project, this direct injection of funds would generate additional positive indirect and induced economic impacts. As the amount of funds in the regional economy expands, local merchants and service providers would see an increase in their sales. In response to the increase in demand for their goods and services, these merchants/service providers may increase their employment and/or increase the demand for goods and services from their local providers, thereby increasing the positive economic impact of the initial injection of funds into the regional economy.

4.9.2.3 Local Government Revenues and Expenditures

Construction

Construction of the proposed LCCE Gasification plant and Lake Charles CO₂ Capture and Compression facilities could have a minor, positive fiscal impact on local government entities within the Greater Lake Charles area. As described above, the proposed project would increase demand for goods and services in the region. While Leucadia will likely request a sales tax exemption under the Louisiana Department of Revenue’s Machinery & Equipment sales tax exemption rule, the added economic activity in the region resulting from the construction could result in local government entities experiencing an increase in sales tax receipts.

Local government expenditures are not expected to increase as a result of construction of the proposed project. During the 36-month construction period, a maximum of 45 transient workers are expected to temporarily relocate to the area. As discussed in previous sections, this increase in total population would be minor given the relative size of Calcasieu Parish. Therefore, construction of the proposed project would not substantially increase the demand for governmental services, resulting in a negligible impact on total expenditures of local government entities.

Operation

Operation will have a positive fiscal impact on local government entities within the Greater Lake Charles area. As described above, operation of the proposed project would increase income in the regional economy and thus would increase the overall demand for goods and services in the region. In addition, nearly 40% of all operations and maintenance costs are expected to be spent in the regional economy, further increasing the sales of goods and services in the regional economy. As a result, local government entities in the region would experience an increase in sales tax receipts due to this additional economic activity within their jurisdictions.

Local government expenditures are not expected to increase as a result of the operation of the proposed project. During operations, approximately 19 permanent workers are expected to relocate to the area with members of their households. As discussed in previous sections, this increase in population will be minor relative to the total population of Calcasieu Parish. Therefore, the operation will not increase the demand for governmental services, resulting in a negligible impact on the total expenditures of local government entities.

4.9.2.4 Community Services

Construction

During construction, the proposed LCCE Gasification plant and Lake Charles CO₂ Capture and Compression project is expected to have a minor, temporary impact on community services in Calcasieu Parish. Local police and fire departments, as well as health care providers, could be called upon to provide services in the unlikely event of a construction-related emergency. Local police departments also may be called upon to assist in traffic management to support the mobilization of people and materials to the construction site. Potential issues, such as the designation of detours to accommodate oversized loads and traffic management at intersections within the Greater Lake Charles area, would likely arise during the construction phase of the project. It is expected that services such as the issuance of special permits (e.g., due to load and width limits) and traffic enforcement would be required.

Solid waste generated by construction activities would also place temporary demands on local solid waste facilities and recycling centers. The waste materials produced during construction would be transported to solid waste transfer stations and refuse centers for recycling or disposal. Nonhazardous wastes would be hauled to local sanitary landfills. Hazardous wastes generated during construction would be sent to a permitted treatment or disposal facility.

As described in Section 2.4.1.1, approximately 6,000 gallons of water would be used daily for dust control, concrete mixing, sanitary uses, cleaning, and fire protection during construction. This increase in demand for water would have a minor, temporary impact on municipal water supplies during the construction period.

These increases in the demand for emergency services, solid waste disposal, and water supply are expected to be met by existing community services and facilities and are not expected to require additional expenditures by local service providers.

As previously noted in Section 4.9.2.1.1, no substantial in-migration of workers is expected during the construction phase. An estimated 45 transient workers are expected to relocate to the area during the construction phase of the project. These workers are not expected to

substantially increase the demand for community services and facilities. Furthermore, any in-migration experienced by communities within the Greater Lake Charles area would be temporary in nature and could be accommodated by existing facilities.

Operation

Operation is not expected to have an impact on the provision of community services in Calcasieu Parish. Local emergency providers, as well as municipal water and wastewater providers, would serve the gasification plant. However, the increase in demand resulting from operation of the plant and capture and compression facilities is expected to be minimal.

In addition, as described in Section 4.9.2.1.1, operation of the plant is expected to result in the relocation of approximately 48 persons (i.e., operations workers and their family members) to the Greater Lake Charles area. This number is approximately 0.02% of the regional population; therefore, no impacts on community facilities or the provision of community services are expected.

4.9.2.5 Environmental Justice

Environmental justice impacts are defined as disproportionately high and adverse human health or environmental effects on minority and/or low-income populations. The COC analysis of the study area within 1 mile of the LCCE Gasification plant described in Section 3.9.2.1 and in Table 3.9-19 did not identify any potential environmental justice areas. Therefore, there are no environmental justice impacts.

4.9.3 Lake Charles CCS Project

4.9.3.1 CO₂ Capture and Compression Facilities

Construction of the Lake Charles CO₂ Capture and Compression facilities and the socioeconomic and environmental justice evaluations and impacts is included in the overall construction and operation of the LCCE Gasification plant.

4.9.3.2 CO₂ Pipeline

4.9.3.2.1 Proposed Route

Population and Housing Impacts

Construction. Construction of the proposed route is not expected to result in large-scale migration of new residents to the Greater Lake Charles area. The construction phase would occur within a 3 to 4-month period and would require an average of approximately 100 workers, with the total number of construction workers reaching 250 at peak construction times. These positions are considered temporary and are not expected to have a long-term impact on local population levels. Local workers would be hired to the maximum extent practicable to further reduce the number of transient workers needed to complete the pipeline route.

There would be a short-term, minor impact on the regional housing market during the construction phase of the proposed pipeline. The influx of an average of 100 transient workers for 3 months would increase the demand for temporary housing such as hotel/motel rooms, RV sites, and other rental properties. However, the expected increase in demand for temporary housing units represents only 0.1% of the housing stock in the Greater Lake Charles area and only 2.8% of the available rental housing units in the area in 2010. Impacts may be more acute

during peak construction periods when the construction workforce reaches its maximum. However, given the short duration of the construction period these impacts are expected to be temporary and relatively minor.

Operation. During the operational phase, only two additional permanent jobs are anticipated to be required to maintain and operate the proposed pipeline route. It is anticipated that these operational workers would be hired locally and would, therefore, not impact the total population in the Greater Lake Charles area. Likewise, operation of the proposed pipeline route would not have an impact on the demand or supply of housing in the Calcasieu Parish. Eight existing residences are located within 50 feet of the proposed pipeline ROW.

Operation of the proposed pipeline is not expected to have an impact on the values of properties in the vicinity of the pipeline ROW. There are several aspects to assessing potential property value impacts due to the presence of CO₂ pipeline easements and associated facilities. Both short- and long-term potential impacts, as well as the likelihood of catastrophic events, need to be considered to address stakeholder concerns. Short-term potential impacts include low-probability accidents, while long-term potential impacts include the perceived risks from living in proximity to these facilities under a normal operating environment.

A literature search of technical economic journals was completed to determine the impacts on the housing market from the operation of the proposed pipeline. The search did not uncover any studies relating to the impact of carbon dioxide pipelines on nearby property values. However, the literature review did provide studies that examined long-term impacts of natural gas pipelines on property values. Most of the studies relied on actual arm's-length sales transfer data for residential properties in close proximity to these facilities. The following is a condensed summary of one of these studies.

The Interstate Natural Gas Association of America Foundation commissioned a comprehensive property value impact study of four natural gas pipeline areas in 2001. The study examined four separate geographically diverse areas traversed by natural gas and petroleum product pipelines. Paired sales analysis, descriptive statistics, and linear regression analysis were applied to sales transfers near these facilities to assess impacts. The conclusions were based on the cumulative results of the four case studies and indicated no significant impact on the sales price of properties located along the natural gas pipelines. Pipeline size (diameter) and the product carried by a pipeline did not have any significant impact on sales prices. Furthermore, there was no discernible impact on the demand for properties located along these facilities, nor did the presence of these facilities impede development of properties in the surrounding area. The researchers concluded that the study's results would apply to other market situations involving pipelines in other regions of the country (INGAA 2001).

Economy and Employment

Construction. Construction of the proposed pipeline would have a moderate short-term positive impact on the economies of local communities within the Greater Lake Charles area. Approximately \$17.2 million would be spent to build the proposed pipeline, with approximately 35% of this total being spent directly in the local economy. An average of 100 construction workers would be needed for 3 months to construct the pipeline, and at peak construction periods, this figure could grow to 250 workers. To the maximum extent practicable, local

construction workers would be utilized. Calcasieu Parish and other surrounding communities would benefit directly from the increase in employment and earnings resulting from this construction, as well as indirectly from the increased economic activity that would occur in the region. These positive economic impacts would last only as long as the construction phase and would, therefore, be short-term in nature.

Operation. Unlike the construction phase, the benefits from operating the proposed route would be long-term in nature and would last as long as the pipeline is in operation. During the operational phase, an additional \$0.5 million is expected to be spent annually on operational and maintenance activities of the proposed pipeline. As previously noted, approximately two additional permanent workers would be employed by the pipeline company to operate and maintain the lateral. Portions of the operating costs/payroll expenses would be spent in the local economy and would also have the same multiplier, or spin-off, impact described in previous sections. Although these benefits are expected to be less than those during the construction phase, they would extend throughout the useful life of the proposed pipeline.

Local Government Revenues and Expenditures

Construction. Construction of the proposed pipeline would have a positive fiscal impact on the local governments traversed by the pipeline. As described above, the proposed pipeline would increase the demand for goods and services in the region economy. While Denbury would likely request a sales tax exemption under the Louisiana Department of Revenue's Machinery & Equipment sales tax exemption rule, the added economic activity in the region resulting from the construction could result in local government entities experiencing a slight increase in sales tax receipts.

Local government expenditures are not expected to increase as a result of the construction of the proposed pipeline. During the 3-month construction period, an average of 100 transient workers are expected to temporarily relocate to the area. As discussed in previous sections, this increase in total population would be minor relative to the size of the population of Calcasieu Parish. Therefore, construction of the proposed pipeline route would not substantially increase the demand for governmental services, resulting in a negligible impact on total expenditures of local government entities.

Operation. In the State of Louisiana, companies owning pipelines are responsible for paying ad valorem (property) taxes to the local governments traversed by the line. Property taxes are assessed on the value of the real estate, the line value, and on all other property (Louisiana Tax Commission 2009). Typically for ad valorem tax purposes in the State of Louisiana, the total assessed value of pipeline infrastructure is 15% of the property's fair market or use value.

If the total construction cost, including land acquisition costs, of the proposed pipeline is \$17.2 million, then completion of the proposed pipeline is expected to increase the ad valorem tax base in the city of Sulphur by a total of approximately \$1.1 million and in Calcasieu Parish by a total of approximately \$3.9 million. In addition, local government entities in the region would experience an increase in sales tax receipts as a result of the additional economic activity that would occur within their jurisdictions.

Local government expenditures are not expected to increase as a result of operation of the proposed pipeline. During the operational phase of the proposed pipeline, two additional permanent jobs would be created. Even if these employees relocate to the region with members of their households, the impact would still be negligible.

Community and Public Services

Construction. Construction of the proposed CO₂ pipeline is not expected to have an impact on community services and facilities in the region. Similar to the impacts described above for the LCCE Gasification plant and capture and compression facilities, construction of the CO₂ pipeline could temporarily increase the demand for emergency services, traffic control measures, solid waste disposal facilities, and municipal water supply services. However, given the temporary nature of the construction and the relatively small length of the pipeline, these impacts are expected to be minor.

The addition of an average of 100 construction workers to the Greater Lake Charles area is also not expected to have an impact on the provision of community services. As described in Section 4.9.2.2.1, the proposed pipeline is expected to draw only an average of 100 transient workers to the region for 3 months. Even at peak construction when a maximum of 250 workers would be on-site the additional workers would represent an increase of only 0.1% of the total population in Calcasieu Parish. Therefore the demand for community services is not expected to experience a noticeable increase as a result of these temporary workers.

Operation. Operation of the proposed CO₂ pipeline would require approximately two additional workers and is not expected to have any substantial impact on community services and facilities in the Greater Lake Charles area or in Calcasieu Parish in particular. The operation of the proposed pipeline would not require the use of emergency services, water or wastewater facilities, or solid waste disposal services. In addition, as described in Section 4.9.2.1, operation of the pipeline is not expected to result in the relocation of any workers to the Greater Lake Charles area; the operations and maintenance staff are expected to be hired locally. Therefore, negligible impacts on the provision of community services or facilities would be anticipated.

Environmental Justice

Environmental justice impacts could occur due to construction and operation of the proposed CO₂ pipeline. As described in detail in Section 3.9.2.2 in Table 3.9-20, twenty-three census groups within the four census tracts in the Study Area have a significantly higher proportion of minority and/or Hispanic populations than the COC, and consequently are potential environmental justice areas. In addition, of these 23 census groups, 14 census groups are also located in a census tract with a significantly larger proportion of the population living below the poverty level than in the COC, also making them potential environmental justice areas. No substantial, unmitigated negative human health or environmental impacts resulting from construction and operation of the proposed CO₂ pipeline have been identified; therefore, there would be no disproportionate impacts on minority, Hispanic, and/or low-income residents.

4.9.3.2.2 Alternative Route B

Socioeconomic impacts resulting from construction and operation of the pipeline along the alternative route are expected to be similar to those described under the proposed route. The

construction phase of the alternative route would require approximately 250 temporary workers, while the operational phase would require approximately two additional permanent workers.

Construction and operation of the pipeline along the alternative route would have a moderate short-term beneficial impact and a minor long-term impact on the local economy. Approximately \$4.8 million is expected to be injected into the regional economy if the pipeline is constructed along the alternative route. An additional \$0.5 million is expected to be spent annually on operational and maintenance activities. This injection of funds into the regional economy would be associated with the same positive “multiplier” effects and temporal conditions as under the proposed route.

Construction of the pipeline along the alternative route would have a similar fiscal impact on the local governments traversed by the pipeline ROW as described under the proposed route. If total construction costs, including land acquisition costs, of the alternative route is \$17.2 million then completion of the proposed project is expected to increase the ad valorem tax base in the city of Sulphur by a total of approximately \$1.1 million, and in Calcasieu Parish by a total of approximately \$3.9 million. Impacts on community facilities and services resulting from construction and operation of the pipeline along the alternative route are expected to be the same as those described under the proposed route.

Environmental Justice

Environmental justice impacts could occur due to construction and operation of the CO₂ pipeline along the alternative route. As described in detail in Section 3.9.2.2 in Table 3.9-21, twenty-five census groups within the six census tracts in the Study Area have a significantly higher proportion of minority and/or Hispanic residents than in the COC, which are therefore potential environmental justice areas. In addition, of these 25 census groups, seven census groups are also located in a census tract with a significantly larger proportion of the population living below the poverty level than in the COC, also making them potential environmental justice areas. No negative human health or environmental impacts resulting from construction and operation of the CO₂ pipeline along the proposed alternative route have been identified; therefore, there would be no disproportionate impacts on minority, Hispanic, and/or low income residents.

4.9.3.3 West Hastings Research MVA

Socioeconomics

The proposed activities are mostly related to the reworking of existing wells and data gathering, and no substantial impacts on the population, housing, or economy of the region, or on the fiscal condition or provision of community services or facilities are expected to occur. The West Hastings research MVA program would create approximately 14 jobs during the research MVA activities for a 4-month duration and 7 operations jobs for up to a 4-year duration (APCI 2011).

Furthermore, the proposed West Hastings research MVA program could have the positive impact of helping to ensure the long-term economic and financial viability of CO₂ capture activities by confirming storage of CO₂ injected in EOR operations. Information collected during the West Hastings research MVA program would provide additional, unique data on the effectiveness of CO₂ sequestration in EOR operations. The data could help establish the commercial viability of CO₂ capture and sequestration technologies.

Environmental Justice

Environmental justice impacts are defined as disproportionately high and adverse human health or environmental effects on minority or low-income populations. As described in Section 3.9.2.3 in Table 3.9-22, the Study Area in the vicinity of the West Hastings research MVA site has a similar percentage of persons living below the poverty level as in the COC; however, it has a significantly larger proportion of residents who are of minorities and/or Hispanic compared to the cities, county, and state populations. In addition, 68 census groups within the five census tracts in the Study Area have a significantly larger proportion of minority and/or Hispanic population than in the COC. Of these 68 census groups, 48 census groups are also located in three census tracts that have a significantly larger proportion of the residents living below the poverty level than in the COC. Therefore, these are potential environmental justice areas. However, no substantial, unmitigated, negative human health or environmental impacts resulting from the research MVA activities have been identified; therefore, there would be no disproportionate impacts on minority, Hispanic, and/or low-income residents.

4.9.4 Summary of Impacts

Tables 4.9-1 and 4.9-2 present summaries of the socioeconomic impacts and minimization measures for the LCCE Gasification plant and the Lake Charles CCS project.

Table 4.9-1 Summary of Potential Impacts on Socioeconomics and Environmental Justice and Minimization Measures for LCCE Gasification Plant and Off-site Activities

Potential Impacts	Minimization Measure(s)
<p>Construction: Minor Construction would temporarily increase employment in the region during the 36-month construction period and would require a peak of 900 workers on site and 2,500 in the surrounding area. The increase in demand for temporary housing would temporarily reduce vacancy rates for such properties throughout the region and would provide short-term economic benefits to owners of temporary housing in the region.</p>	<p>No minimization measures would be necessary because adequate housing exists in the region.</p>
<p>Operation: Minor Operation would require 187 new permanent workers. Approximately 90% of these additional workers would be hired from the existing local labor market and 19 permanent workers would relocate to the area.</p>	<p>No minimization measures would be necessary because adequate housing exists in the region.</p>

Table 4.9-2 Summary of Potential Impacts on Socioeconomics and Environmental Justice and Minimization Measures for Lake Charles CCS Project

Potential Impacts	Minimization Measure(s)
<p>Construction and Operation of the CO₂ Capture and Compression Facilities: Minor Included in the LCCE Gasification plant (see Table 4.9-1)</p>	<p>Included in the LCCE Gasification plant (see Table 4.9-1)</p>
<p>Construction of the CO₂ Pipeline or Alternative Pipeline: Minor Construction would require an average of approximately 100 workers, with a total of 250 workers during peak construction periods. Demand for temporary housing such as hotel/motel rooms, RV sites, and other rental properties would increase providing a benefit to local providers. The area as a whole is not considered an environmental justice area; however certain census tracts have significantly higher proportions of minority and/or Hispanic populations and populations below the poverty level.</p>	<p>No minimization measures would be necessary.</p>
<p>Operation of the CO₂ Pipeline or Alternative Pipeline : Negligible Two additional workers would be hired to maintain and operate the proposed pipeline route. The workers would be hired locally and would not impact the total population in the Greater Lake Charles area.</p>	<p>No minimization measures would be necessary.</p>
<p>Operation of the West Hastings research MVA program: Negligible An additional 14 jobs for 4 months and seven operations jobs for up to 4 years would be created. Census tracts in the area have a significantly larger proportion of minority and/or Hispanic population than Brazoria County or Texas.</p>	<p>No minimization measures would be necessary.</p>

4.10 Traffic and Transportation

4.10.1 Factors Considered for Assessing Impacts

The DOE assessed the potential for impacts on traffic and transportation based on whether the proposed project or connected action would:

- Decrease or disrupt existing primary access on public roads through the area,
- Degrade the level of service (LOS) for any local roads,
- Cause loss of authorized access to private parcels, or
- Conflict with local or regional transportation plans.

DOE used standard methods described in the Highway Capacity Manual (HCM; TRB 2010) to assess the potential impacts to the Level of Service (LOS) or functional quality and capacity of transportation resources for the LCCE Gasification plant. The HCM is an industry standard reference for LOS analysis and provides the best available operational, planning, and design methodologies for estimating and predicting the LOS of roadways. LOS measures the quality of service of a roadway. Six levels of service are assigned letter designations ranging from A to F with LOS A (free flow, little delay) representing the best operating conditions from the traveler’s perspective and LOS F the worst (congestion, long delays) (TRB 2010). Factors used to estimate LOS include capacity, demand, demand volume, volume/capacity (v/c) ratio, and traffic density. The HCM operational and planning methodologies for basic freeway segments, multilane highways, and two-lane highways, described in the HCM, were used to estimate the potential change in LOS of local roadways that could potentially occur during construction of the proposed project. The LOS analysis used multiple inputs to estimate LOS including:

- Roadway characteristics
- Local 2010 Annual Average Daily Traffic Volumes (AADT)
- Peak Portion of AADT Factors (K), Peak Direction Factors (D) and Heavy Truck factors estimated using the MTP 2034 plan.

LOS on a basic freeway segment is defined by density. Density describes the proximity to other vehicles and is related to the freedom to maneuver within the traffic stream and unlike speed, density is sensitive to demand flow rates throughout the range of flows. The values in Table 4.10-1 represent national norms associated with the capacity of basic freeway segments under base conditions.

Table 4.10-1 LOS Criteria for Basic Freeway Segments at 70 mph

LOS	Maximum Flow Rate (cars/hour/lane)	Density (cars/mile/hour)
A	770	≤11
B	1,250	>11-18
C	1,690	>18-26
D	2,080	>26-35
E	2,400	>35-45
F	>2,400	>45

Levels of Service for multi-lane highways are also defined by density. The values in Table 4.10-2 represent national norms associated with the capacity of basic multi-lane highways under base conditions. DOE assumed that roads evaluated using the multi-lane highway analysis methodology were un-interrupted flow roadways with limited access points and no signalization.

Table 4.10-2 LOS Criteria for Multi-Lane Freeway Segments at 55 mph

LOS	Maximum Flow Rate (cars/hour/lane)	Density (cars/mile/hour)
A	600	≤11
B	990	>11-18
C	1,430	>18-26
D	1,850	>26-35
E	2,100	>35-41
F	>2,100	>41

Due to the wide range of situations in which two-lane highways are found, three measures of quality and effectiveness; Average Travel Speed, Percent of Time Following, and Percent of Free Flow Speed, are used as inputs in the HCM methodologies for two lane highways to estimate LOS (TRB 2010). Table 4.10-3 describes LOS criteria for two-lane highways. DOE assumed that roads evaluated using the two-lane highway analysis methodology had limited access points and minimal signalization.

Table 4.10-3 LOS Criteria for Two-Lane Highway Segments at 45 mph

LOS	Class I		Class II	Class III
	Average Travel Speed (mph)	Percent Time Spent Following (%)	Percent Time Spent Following	Percent Free Flow Speed
A	>55	<35	<40	>91.7
B	>50-55	>35-50	>40-55	>83.3-91.7
C	>45-50	>50-65	>50-70	75.0-83.3
D	>40-45	>65-80	>70-85	>66.7-75.0
E	<40	>80	>85	<66.7

DOE used the MPO’s 2014 Volume/Capacity (v/c) ratio estimates in conjunction with the LA DOTD estimates of 2012 LOS for roadway networks in the Lake Charles – Sulphur area to establish a baseline LOS for evaluating potential impacts to transportation resources. The Lake Charles Area Urbanized Area transportation system is the network of transportation related facilities and activities that moves both people and goods through the community by connecting its residential and commercial areas within the urbanized area, as well to the external world. The transportation system includes streets, highways, rail lines, waterways, ports, airports, and intermodal facilities. DOE used the IMCAL 2009 MPO model to project future volume/capacity ratios and LOS for transportation networks within the Lake Charles Urbanized Area.

Future traffic volumes for the proposed 36-month construction period beginning in 2014 include trip generation estimates from the proposed project and connected action. A 3.5% traffic escalation factor was applied to each construction year to represent the likely escalation of the 2010 baseline traffic volumes during the construction period. The future traffic volumes for 2013-2015 were used as inputs into the HCM methodologies to estimate LOS.

4.10.2 LCCE Gasification (Connected Action)

4.10.2.1 Construction

Leucadia would use off-site parking for the construction workers during construction. Up to six 40-passenger shuttle buses would transport personnel 3 miles from the off-site construction parking area located on State Hwy 108 west of Hwy 27 to the construction site on Bayou D’Inde

Road. A maximum of approximately 900 personnel would travel to and from the construction parking area daily during the 14 month peak construction period. A total of 46 shuttle trips would be required per day to transport all 900 workers to and from the parking area. Although it is not currently planned, Leucadia may temporarily require a second work shift or overtime shift; it is unknown whether such a second shift would be required or what its size and duration would be.

Approximately 150 off-site construction vehicles would deliver concrete, asphalt, and equipment to the site daily during peak construction when foundations are being poured. After foundation work is completed, Leucadia estimates a maximum of 100 two-way trips would occur daily to transport equipment and materials to the construction site. Table 4.10-4 shows the distribution of trips along local roadways that would potentially be generated by personnel during construction of the proposed project. The trip generation estimate includes commuter traffic, construction parking site shuttles and delivery vehicles.

Table 4.10-4 Peak One-Way Commuter, Shuttle, and Delivery Trip Distributions During Construction (per day)

Roadway	Trips
I-10 Westbound	690
I-10 Eastbound	460
State Hwy 108 at I-10 (City Services Hwy)	474
State Hwy 108 west to State Hwy 1133	474
State Hwy 108 west to State Hwy 27	474
State Hwy 27/108 at State Hwy 1256 south	374
State Hwy 27	173
State Hwy 1256/Ruth Street I-10 to McNair Street	266
State Hwy 1256/Ruth Street south of Short Street	266
State Hwy 27 south of State Hwy 108	107
Bayou D'Inde Road and Hwy 108	328

The results of the analysis did not indicate any major short or long-term impacts to interstate, multilane highway, or two lane highway transportation resources would occur as a result of construction. As described in Table 3.10.5, many of the roads to be used during construction currently operate at moderate (LOS C) to Poor (LOS E) conditions. Table 4.10-5 presents the projected results of the HCM 2012 Basic Freeway Operational LOS analysis for local I-10 segments. 2012 LOS estimates indicate that I-10 exhibits gridlock during peak A.M. and P.M. hours along a segment between the I-10/I-210 interchange and the I-10 Calcasieu River Bridge in the eastbound direction (DOTD 2012c). Gridlock is the failure of a roadway to discharge traffic and is represented by an LOS designation of F. This segment of I-10 exhibits an LOS of F because the I-10 eastbound travel lanes transition from three lanes in each direction to two lanes in each direction as I-10 approaches the I-210 interchange, which causes a rapid reduction in capacity as traffic travels towards the functionally obsolete Calcasieu River Bridge. The additional daily traffic volume that would be generated on I-10 as a result of construction would be 1.7 % of the annual average daily traffic volumes when compared to the existing and projected average and peak demand volume for I-10 during the peak construction period. Although one segment of I-10 is operating at LOS F, construction would result in no impacts to I-10.

Table 4.10-5 Projected LOS of I-10 Segments during Construction using the HCM 2012 Basic Freeway Operational Methodology

Roadway	2010 AADT ¹	2012 LOS ²	Projected No Build 2014 LOS ³	2013 Peak Demand Volume ⁴	2013 LOS	2014 Peak Demand Volume ⁴	2014 LOS	2015 Peak Demand Volume ⁴	2015 LOS
Interstate 10 Hwy 1256 to the I-210 Interchange	77,721	C	C/D	2,075	C/D	2,146	D	2,220	D
Interstate 10 I-210 Interchange East to Lake Charles	60,107	F	F	2,887	F	2,986	F	3,089	F

* 2009 AADT obtained from IMCAL 2012

¹ 2010 AADT obtained from the DOTD Traffic Count database

² 2012 LOS estimated from DOTD planning records.

³ Projected 2014 LOS estimated from MTP 2034 Travel Demand Model forecasts.

⁴ Peak Demand Volume in cars per mile per hour estimated using Peak Proportion of AADT (K), Peak Direction (D) and Heavy Truck factors obtained from coordination with DOTD and review of the MTP 2034.

Table 4.10-6 presents the projected results of the HCM 2012 Multi-Lane Operational LOS analysis for local multi-lane highway segments. The results of the HCM analysis indicate that the LOS of one segment of State Hwy 108 is estimated to degrade from A to B near State Hwy 1133. No other changes were estimated to occur as a result of construction of the gasification plant and off-site activities.

Table 4.10-6 Projected LOS of Local Multi Lane Highways during Construction Using the HCM Multi-Lane Highway Operational Methodology

Roadway	2010 AADT ¹	2012 LOS ²	Projected No Build 2014 LOS ³	2013 Peak Demand Volume ⁴	2013 LOS	2014 Peak Demand Volume ⁴	2014 LOS	2015 Peak Demand Volume ⁴	2015 LOS
State Hwy 108 at I-10 (City Services Hwy)	18,777	C	C	1,038	C	1,072	C	1,107	C
State Hwy 108 west to State Hwy 1133	12,552	A	A	716	B	843	B	868	B
State Hwy 108 west to State Hwy 27	3,671*	B	B	257	A/B	271	A/B	284	A/B
State Hwy 27/108 at State Hwy 1256 south	6,997	C	C	1,478	C	1,601	C	1,787	C/D
State Hwy 27 north of I-10	19,734	C	C/D	1,544	C	1,681	C	1,815	C/D

* 2009 AADT obtained from IMCAL 2012

¹ 2010 AADT obtained from the DOTD Traffic Count database

² 2012 LOS estimated from DOTD planning records.

³ Projected 2014 LOS estimated from MTP 2034 Travel Demand Model forecasts.

⁴ Peak Demand Volume using Peak Proportion of AADT (K), Peak Direction (D) and Heavy Truck factors obtained from coordination with DOTD and review of the MTP 2034.

Although the analysis did not indicate a change in LOS on State Hwy 108 near the construction parking area, short term, minor impacts to State Hwy 108 would likely occur at the entrance to the construction parking area during peak construction. During the peak of construction, approximately 636 workers would access the construction parking area at the beginning and end of each shift. Because more than 100 one way vehicle trips per day would be generated at the entrance of the construction parking area, LAC Title 70 Part I Chapter 15 would require Leucadia to consult with LA DOTD District 7 prior to use of the construction parking area. Leucadia would obtain a temporary construction access permit from DOTD, if required. Use of the construction parking area and shuttle buses would reduce the potential impacts of increased traffic congestion on local roadways by reducing the number of commuter vehicles traveling on local roadways and by minimizing trips to and from the construction site. Leucadia would also schedule heavy equipment deliveries-- that could temporarily block roadways-- during off peak hours to the maximum extent practicable, to minimize potential impacts to transportation resources. Leucadia would minimize impacts to peak morning and evening traffic volumes on local roadways that construction personnel would use to access the construction parking area by:

- Starting work shifts at non-peak hours when feasible.
- Using shuttle buses to transport workers from the construction parking area to the construction site.
- Staggering personnel arrival times at the construction parking area.
- Requiring construction personnel to use roadways with LOS of C or higher to the maximum extent practicable to avoid impacts to local roadways.
- Coordinating potential traffic disruptions with DOTD District 7 and local facilities to avoid peak commuting times.

Table 4.10-7 presents the projected results of the HCM 2012 Two-Lane Operational LOS analysis for local two-lane highway segments during the construction period of the proposed project. As Ruth Street travels south from I-10 towards State Hwy 108, the multi-lane roadway transitions into a two-lane roadway near McNair Street and experiences a reduction in capacity that causes congestion. Segments of Ruth Street currently exhibit moderate to poor LOS (LOS E) between I-10 and McNair Street. These segments are projected to continue to exhibit poor LOS even if the proposed project is not constructed.

Table 4.10-7 Projected LOS of Local Two Lane Highway Segments during Construction Using the HCM Two-Lane Highway Operational Methodology

Roadway	2010 AADT ¹	2012 LOS ²	Projected No Build 2014 LOS ³	2013 % Free Flow Speed	2013 LOS	2014 % Free Flow Speed	2014 LOS	2015 % Free Flow Speed	2015 LOS
State Hwy 1256/Ruth Street south of McNair Street	16,256	E	E/F	73	D	67	E	66	F
State Hwy 1256/Ruth Street south of Short Street	12,191	C	C/D	81	C	79	C	78	C
State Hwy 27 south of State Hwy 108	12,204	C	E/F	81	C	80	C	79	C
Bayou D'Inde Road and Hwy 108	2,247*	not available	B/C	80	C	79	C	78	C

* 2009 AADT obtained from IMCAL 2012

¹ 2010 AADT obtained from the DOTD Traffic Count database

² 2012 LOS estimated from DOTD planning records.

³ Projected 2014 LOS estimated from MTP 2034 Travel Demand Model forecasts.

⁴ Percent Free Low Speed Calculated from the Two Lane Highway Operational Methodology.

Table 4.10-8 summarizes the existing and projected future LOS for transportation resources in the Lake Charles urbanized area that would be used during construction of the LCCE Gasification plant and the Lake Charles CCS project capture and compression facilities. Leucadia would require the use the alternate commuter routes of State Hwy 27 and State Hwy 108 to the maximum extent practicable to avoid further degradation of the LOS of Ruth Street, primarily between I-10 and McNair Street. Based on the estimated existing and projected future LOS of Ruth Street, the use of Ruth Street during peak construction would degrade LOS from E to F. The results of the HCM analysis did not indicate that the LOS of Bayou D'Inde Road would degrade to an LOS below the existing LOS of C during peak construction. However, the LOS of Bayou D'Inde Road could be degraded for short periods of time on days when oversized equipment is delivered to the construction site. Construction would result in minor, short term impacts to transportation resources overall.

Table 4.10-8 Summary of Projected LOS of Transportation Resources during Peak Construction of LCCE Gasification Plant and the Lake Charles CCS Project Capture and Compression Facilities

Roadway	2010 AADT ¹	2012 LOS ²	Projected No Build 2014 LOS ³	201 3 LO S	201 4 LOS	201 5 LOS
Interstate 10 Hwy 1256 to the I-210 Interchange	77,721	C	C/D	C/D	D	D
Interstate 10 I-210 Interchange East to Lake Charles	60,107	F	F	F	F	F
State Hwy 108 at I-10 (City Services Hwy)	18,777	C	C	C	C	C
State Hwy 108 west to State Hwy 1133	12,552	A	A	B	B	B
State Hwy 108 west to State Hwy 27	3,671*	B	B	B	B	B
State Hwy 27/108 at State Hwy 1256 south	6,997	C	C	C	C	C
State Hwy 27 north of I-10	19,734	C	C/D	C/D	C/D	C/D
State Hwy 1256/Ruth Street south of McNair Street	16,256	E	E/F	D	E	F
State Hwy 1256/Ruth Street south of Short Street	12,191	C	C	C	C	C
State Hwy 27 south of State Hwy 108	12,204	C	E/F	C	C	C
Bayou D'Inde Road and Hwy 108	2,247*	not available	B/C	C	C	C

* 2009 AADT obtained from IMCAL 2012

¹ 2010 AADT obtained from the DOTD Traffic Count database

² 2012 LOS estimated from DOTD planning records.

³ Projected 2014 LOS estimated from MTP 2034 Travel Demand Model forecasts.

Leucadia would construct the off-site linears in existing ROWs within industrial areas. During construction of the water supply and hydrogen pipelines, Leucadia would access the temporary and permanent pipeline ROWs and associated facilities through existing public and private roads to the extent practicable. Some of the existing access roads may require modifications or improvements to accommodate the weight and dimensions of construction equipment and materials. If necessary, Leucadia would construct new roads for permanent access to facilities where there is not an existing road. The specific locations of access roads are unavailable and would not be determined until Leucadia finalizes the project design. Existing access roads would be used to the maximum extent to avoid impacts to transportation resources.

Heavy equipment transporters and supply vehicle traffic would travel to the construction area and would remain along the ROW during construction. Construction of the linear facilities would temporarily reduce roadways to one travel lane or require temporary closure to allow construction workers access or facilitate the transport of equipment. Leucadia would install the water supply and hydrogen pipelines under paved roads and some unpaved roads by boring

beneath them. A majority of unpaved road crossings would use the traditional open-cut method, and steel plates would be used to cover the open area to allow passage by emergency vehicles. The construction method would allow for traffic flow across the open area except for the limited periods required for actual pipeline installation.

Construction of the water supply and hydrogen pipelines may cause short-term traffic delays (because of large, slow-moving heavy equipment transporters and delivery trucks). The delays would be temporary and minimized through the following measures:

- Providing notices to adjacent landowners when construction would take place to minimize access disruptions.
- Providing proper road signage and warnings of “Equipment on Road,” “Truck Access,” or “Road Crossings.”
- Implementing traffic diversion equipment (such as advance signage and pilot cars) whenever possible when slow or oversize loads are being hauled.
- Encouraging carpooling by the construction workforce to reduce traffic volume.
- Employing flaggers as necessary to direct traffic when large equipment is exiting or entering public roads to minimize the risk of accidents.
- Maintaining at least one travel lane at all times so that roadways would not be closed to traffic due to construction vehicles entering or exiting public roads.

Construction-related traffic would result in short-term, minor impacts along the hydrogen and raw waterline pipeline route as well as off-site linears and off-site parking, equipment laydown, and methanol and sulfuric acid storage areas.

With respect to regional transportation plans, the MTP 2034 does not propose any funded transportation projects that would occur during the construction of the proposed gasification plant, CO₂ capture and compression facilities, or CO₂ pipeline. Several un-funded transportation project proposed in the MPT2034 plan include:

- Replacement of the I-10 Calcasieu River Bridge
- Expansion of Ruth Street from two to four lanes between I-10 and LA 108
- Extension of LA 108 from I-10 to the Houston River
- Expansion of US Hwy 90 from PPG Road to Post Oak

The projects listed above are currently not funded; however if the projects obtain funding in 2013 or 2014; construction would not occur before 2018, well after the construction of the proposed project and connected action is completed in 2017. DOTD is proposing one large project to widen I-10 in both directions between Sulphur and Westlake, LA by 2025. Calcasieu

Parish is proposing a new road connecting LA1256 (Ruth Street) to LA 27, however this construction would occur in 2025.

4.10.2.2 Operation

Leucadia would employ an average of approximately 187 personnel during operation, including operators and maintenance, management, engineering, safety, warehouse, and contractor personnel. Some of these operations workers would commute to the methanol and sulfuric acid storage area. The 187 operations workers would generate 204 daytime roundtrip and 44 nighttime roundtrip vehicle trips per day, which are minimal compared to the annual average daily traffic counts shown in Table 3.10-3. Periodic maintenance of the ROW for the hydrogen and water supply pipelines would include mowing and occasional maintenance activities that may require access to buried portions of the utilities. Leucadia would use the same procedures to access the ROW and property as during construction. Operation of the off-site activities, including the hydrogen and raw water pipelines would have negligible impacts on traffic and transportation infrastructure.

During operation, approximately 127 one-way truck trips would be generated daily to remove waste materials for disposal, export materials, or to deliver process materials, fuel, lubricants, and chemicals. Based on the minimal number of trips that would be generated by operations personnel and deliveries to and from the gasification plant, operation of the LCCE Gasification plant would have negligible impact on traffic or transportation infrastructure.

4.10.3 Lake Charles CCS Project

4.10.3.1 CO₂ Capture and Compression Facilities

Traffic associated with construction and operation of the LCCE Gasification plant includes the CO₂ capture and compression facilities. The number of vehicles associated with the construction of CO₂ capture and compression facilities is included in the estimate of commuter vehicles, shuttles, and delivery vehicles associated with the LCCE Gasification plant under 4.10.2.1 and construction and operation of the CO₂ capture and compression facilities would have no additional impact on traffic or transportation infrastructure.

4.10.3.2 CO₂ Pipeline

4.10.3.2.1 Proposed Route

Construction

The construction of the CO₂ pipeline would proceed in the manner of an outdoor assembly line and consist of specific activities that make up the linear construction sequence. On average, approximately 100 personnel, working in various work crews (clearing, grading, trenching, inspection, environmental, etc.) would access the pipeline route daily during construction. Work crews would operate at different points along the pipeline route and would park up to 50 vehicles at staging areas or at designated work locations along the pipeline route during the day. On average, the work crews would generate up to 100 vehicle roundtrips per day. Approximately 20 pipeline inspectors would use up to 10 trucks to travel from one segment of the pipeline to the next.

During construction of the CO₂ pipeline, access to the temporary and permanent pipeline ROWs and associated facilities would be through existing public and private roads to the extent practicable. Some of the existing private access roads would require modifications or

improvements to accommodate the weight and dimensions of construction equipment and materials. If necessary, Denbury would obtain regulatory and landowner approval to construct new access roads for permanent access to facilities in locations where an existing access road does not exist. Heavy equipment transporters and supply vehicle traffic would travel to the construction area and remain along the proposed route ROW during construction. Traffic volume that would be generated from smaller vehicles, such as pickups and automobiles used by construction staff to access the ROW, would cause negligible temporary increases in local traffic volume along the proposed pipeline route. Denbury would construct road and railroad crossings in accordance with applicable state and local regulations and permits.

With the exception of road crossings that would occur within the HDD paths for waterbody crossings, Denbury would install the pipeline under paved roads and some unpaved roads by boring beneath them. Denbury would cross a majority of unpaved roads using the traditional open-cut method, and steel plates would be used to cover the open area to allow passage by emergency vehicles. The construction method would allow for traffic flow across the open area except for the limited periods required for actual pipeline installation. Open-cut road crossings would be constructed in one day. Steel plates would be placed across the cut until fill is properly compacted. Denbury would minimize impacts to transportation resources through the following measures:

- Providing notices to adjacent landowners when construction would take place to minimize access disruptions.
- Providing proper road signage and warnings of “Equipment on Road,” “Truck Access,” or “Road Crossings.”
- Implementing traffic diversion equipment (such as advance signage and pilot cars) whenever possible when slow or oversize loads are being hauled.
- Encouraging carpooling by the construction workforce to reduce traffic volume.
- Employing flaggers as necessary to direct traffic when large equipment is exiting or entering public roads to minimize the risk of accidents.
- maintaining at least one travel lane at all times so that roadways would not be closed to traffic due to construction vehicles entering or exiting public roads.

Construction-related traffic would result in short-term, minor impacts along the pipeline route.

Operation

Periodic maintenance of the ROW would include mowing and occasional maintenance activities that may require access to buried portions of the utilities. Denbury would use the same procedures to access the ROW and property as during construction. Operation of the pipeline would have negligible impacts on traffic or transportation infrastructure.

4.10.3.2.2 Alternative Route B

Construction of the pipeline along alternative route B would result in traffic and transportation impacts similar to those described for the proposed pipeline route, except that the alternative

route is slightly shorter and would use segments of I-10 and State Hwy 108 located west of the proposed pipeline route. Operation of the pipeline along this route would have negligible impacts on traffic or transportation infrastructure.

4.10.3.3 West Hastings Research MVA

Existing Denbury personnel would perform the research MVA activities as part of the ongoing commercial EOR at the West Hastings oil field with support from BEG. Impacts on local traffic related to new personnel hired by Denbury, expected to be 14 employees (APCI 2011), as well as BEG personnel that would conduct temporary site visits would be negligible. Well reworking activities would not require new roads or the expansion of the existing roads. Temporary, negligible impacts to transportation resources would occur during surveying and monitoring, however MVA operations would have negligible impacts on traffic or transportation resources.

4.10.4 Summary of Impacts

Tables 4.10-9 and 4.10-10 present summaries of the traffic and transportation impacts and minimization measures for the LCCE Gasification plant and the Lake Charles CCS project.

Table 4.10-9 Summary of Potential Impacts on Traffic and Transportation and Minimization Measures for LCCE Gasification Plant and Off-site Activities

Potential Impacts	Minimization Measure(s)
<p>Construction: Minor Approximately 900 workers would access the off-site construction parking area daily. Approximately 150 off-site construction vehicles would deliver concrete, asphalt, and equipment to the site daily during peak construction. Use of Ruth Street during peak construction would degrade LOS from E to F, which is the worst operating condition from a traveler’s perspective.</p>	<p>Leucadia would use shuttle buses from the off-site construction parking area to reduce traffic congestion on local roadways. To the extent practicable, Leucadia would schedule heavy equipment deliveries during off peak hours, start work shifts at non-peak hours, stagger personnel arrival times at the off-site construction parking area, request that construction personnel use roadways with LOS of A, B, or C, and coordinate traffic congestion with DOTD District 7.</p> <p>Leucadia would obtain a temporary construction access permit from DOTD for the off-site construction parking area, if required.</p>
<p>Operation: Negligible Approximately 187 personnel would access the site during operation. Approximately 81 one-way truck trips would access the site daily to remove waste materials or deliver materials.</p>	<p>No minimization measures would be necessary.</p>

Table 4.10-10 Summary of Potential Impacts on Traffic and Transportation and Minimization Measures for Lake Charles CCS Project

Potential Impacts	Minimization Measure(s)
<p>Construction and Operation of the CO₂ Capture and Compression Facilities: Minor Included in the LCCE Gasification plant (see Table 4.10-9)</p>	<p>Included in the LCCE Gasification plant (see Table 4.10-9)</p>
<p>Construction of the CO₂ Pipeline or Alternative Pipeline: Minor On average, approximately 100 personnel and 10 trucks would access the pipeline route daily during construction.</p>	<p>Denbury would obtain regulatory and landowner approval to construct new access roads, if necessary, and roads and railroad crossings would be constructed in accordance with applicable state and local regulations and permits.</p> <p>Denbury would minimize impacts by providing notices to adjacent landowners regarding construction times, providing proper road signage and warnings, implementing traffic diversion equipment, encouraging carpooling, employing flaggers, as necessary, and maintaining at least one travel lane at all times.</p>
<p>Operation of the CO₂ Pipeline or Alternative Pipeline: Negligible Periodic maintenance of the ROW would include mowing and occasional maintenance activities that may require access to buried portions of the utilities.</p>	<p>If necessary, Denbury would use the minimization procedures used during construction, as described above.</p>
<p>Operation of the West Hastings Research MVA Program: Negligible Approximately 14 additional personnel would access the West Hastings research MVA area.</p>	<p>No minimization measures would be necessary.</p>

4.11 Noise

4.11.1 Factors Considered for Assessing Impacts

Noise is evaluated with respect to public health and welfare and to protect the public and noise-sensitive receptors from impacts that interfere with activities in residential areas. In the absence of local noise standards, the DOE considered EPA and U.S. Department of Housing and Urban Development (HUD) guidelines. DOE assessed potential direct and indirect impacts of noise levels generated by construction and operation activities on sensitive noise receptors. Potential direct and indirect impacts include the following:

- Conflict with any local noise ordinances, or
- Perceptible increases in ambient noise levels at sensitive noise receptors during construction or operation.

The EPA’s *Information on Levels of Environmental Noise Requisite to Protect Public Health and Welfare with an Adequate Margin of Safety* (“EPA Noise Guidance”) (EPA 1974) evaluates the effects of environmental noise with respect to health and safety. The EPA Noise Guidance determined that in order to protect the public from activity interference and annoyance outdoors in residential areas, noise levels should not exceed a day-night average sound level (L_{dn}) of 55 average-weighted decibels (dBA). The EPA accounts for a greater sensitivity of the public to noise levels during the nighttime (specified as 10:00 p.m. to 7:00 a.m.) when most people are typically engaged in activities that require lower background noise levels by setting an L_{dn} that adds 10 dBA to nighttime noise levels. The EPA Noise Guidance considers an L_{dn} of 55 dBA to be the maximum sound level that will not adversely affect public health and welfare by interfering with speech or other activities in outdoor areas. In addition, the Federal Energy Regulatory Commission (FERC) typically uses the 55 dBA sound guideline adopted from EPA noise guidance. HUD has set site acceptability standards outlined in 24 CFR Part 51 for determining the acceptability of federally assisted projects and proposed mitigation measures to ensure that activities assisted by HUD will achieve the goal of a suitable living environment. These standards, summarized in Table 4.11-1, establish a site acceptability standard based on the L_{dn} .

Table 4.11-1 HUD Site Acceptability Standards

	Day-Night Average Sound Level in Decibels (L_{dn})
Acceptable	Not exceeding 65 dB
Normally unacceptable	Above 65 dB but not exceeding 75 dB
Unacceptable	Above 75 dB

Source: HUD 1991.

Currently, no applicable quantitative noise standards for the State of Louisiana apply to the site. Neither Calcasieu Parish nor the City of Lake Charles has a local ordinance that addresses quantitative noise standards for new development or construction activities. Calcasieu Parish prohibits operating construction equipment within 165 feet of a residence or noise-sensitive area (NSA) between sunset and sunrise on Monday through Saturday and between 9 p.m. and 8 a.m. on Sundays and holidays. Operation of construction vehicles and equipment without a muffler is also prohibited. Therefore, DOE used the noise guideline criteria provided by the EPA and HUD as described above to evaluate potential impacts on noise-sensitive receptors. In addition, DOE used the human response to the increase in sound to evaluate the impacts at the nearest noise sensitive receptor. The human response to noise increases, measured in dBA, has the following characteristics (Bies and Hansen 1988):

- A 3 dB change in a continuous broadband noise is generally considered "just barely perceptible" to the average listener.
- A 5 dB change is generally considered "clearly noticeable."
- A 10 dB change is generally considered a doubling (or halving) of the apparent loudness.

DOE analyzed noise levels generated by construction activities using a construction noise model to determine projected noise levels at various distances and receptor locations during a typical

hour of construction. The algorithm in the model considered construction equipment noise specification data, usage factors, and the relative distances of the noise-sensitive receptor to the source of noise. The following logarithmic equation computes projected noise levels:

$$Lp2 = Lp1 + 10\log (U.F.) - 20\log (d2/d1):$$

Where:

Lp2 = the average noise level (dBA) at a noise-sensitive receptor due to the operation of a unit of equipment throughout the day

Lp1 = the equipment L_{max} noise level (dBA) at a reference distance (d1)

U.F. = a usage factor that accounts for a fraction of time an equipment unit is in use throughout the day

d2 = the distance from the receiver to the unit of equipment in feet

d1 = the distance at which equipment noise level data is known (reference distance = 50 feet).

Table 9.1 in the FHWA Highway Construction Noise Handbook provides noise levels (L_{eq}) and usage factor data for construction equipment (FHWA 2006).

The following equation calculates the composite sound contribution at a receptor resulting from the operation of all of the construction equipment:

Operation

The following equation estimates noise at the nearest receptors resulting from operating activities:

$$L_2 = L_1 - 20\log\left(\frac{d_2}{d_1}\right)$$

Where:

L2 = sound level at distance d2

L1 = sound level at distance d1

The estimated noise levels are conservative and do not include reduction of sound level due to atmospheric attenuation, ground absorbance, or transmission loss through structures or vegetation.

The following equation calculates the sound contribution at a receptor resulting from the operation of all of the major noise-producing equipment simultaneously (operating sound pressure level contribution):

$$Leq_{total} = 10\log\left(10^{\frac{Leq_1}{10}} + 10^{\frac{Leq_2}{10}} + 10^{\frac{Leq_3}{10}} \dots etc.\right)$$

The EPA guideline of 55 dBA for the day-night average sound level (L_{dn}) was compared to the L_{dn} for plant operations. The L_{dn} represents the estimated plant operating sound pressure level contribution and the measured ambient hourly equivalent continuous noise level (L_{eq}) for daytime and nighttime hours. The following equation calculates the 24-hour L_{dn} for each receptor:

$$L_{dn} = 10 \log_{10} 1/24 [15 \times 10^{(L/10)} + 9 \times 10^{(L+10)/10}]$$

Where:

L_{dn} = the day-night average sound level
 L = L_{eq} (equivalent continuous noise level)

This includes a 10 dBA penalty on nighttime hourly noise levels (10:00 p.m. to 7:00 a.m.).

4.11.2 LCCE Gasification (Connected Action)

4.11.2.1 Construction

4.11.2.1.1 Gasification Plant

Starting on February 8, 2012, ATCO personnel conducted a 24-hour noise survey around the nearest residential receptors, located on 3055 Bayou D'Inde Road, approximately 4,200 feet northwest of the future facility. Measurements were performed in accordance with ANSI standard S1.13-2005, "*Methods for Measurement of Sound Pressure Levels in Air.*"

Meteorological conditions were also monitored throughout the measurement period. Conditions were within the limits prescribed in ANSI standard S12.9 "*Quantities and Procedures for Description and Measurement of Environmental Sound.*" The survey results indicate that the L_{90} ambient sound level during daytime and nighttime is approximately 53 dBA and the L_{eq} level is approximately 60 dBA. The ambient sound level was mostly determined by traffic noise on Bayou D'Inde Road and noise from the nearby industrial facilities. Noise from the Louisiana Pigment facility was faintly audible during periods of low traffic noise.

Construction would involve the use of mechanical equipment at various stages of construction, including clearing and grading, placing of fill, excavating for foundations, and pile driving. Table 4.11-2 presents typical sound pressure levels (SPLs) at various distances for the construction equipment that would operate during the site preparation phase of construction. Table 4.11-3 presents the typical SPLs at various distances for the noise-producing equipment that would operate during other phases of construction. Construction-related noise impacts at any given location would depend on the type and number of pieces of construction equipment operated and the receptor's distance from the construction site.

Table 4.11-2 Site Preparation Noise Levels at Various Distances

Construction Equipment	Quantity	Usage Factor %	L _{max} SPL @ 50 Feet (dBA)	Distance in Feet/SPL ¹ (dBA)					Nearest Receptor 4,200
				50 (adj.) ²	250	500	1,000	1,500	
Dozer	11	40	82	88	74	68	62	59	50
Trackhoe	5	40	78	81	67	61	55	51	43
Front-end Loader	5	40	79	82	68	62	56	52	44
Graders	2	40	85	84	70	64	58	54	46
Water Pump	8	50	81	87	73	67	61	57	49
Dump Truck	6	40	76	80	66	60	54	50	41
Composite Noise Level				93	79	73	67	63	54

Source: FHWA 2006.

¹ SPL = Sound pressure level.

² SPL adjusted to account for the % usage and quantity of equipment at 50 feet.

Table 4.11-3 Construction Noise Levels at Various Distances

Construction Equipment	Quantity	Usage Factor %	L _{max} SPL @ 50 Feet (dBA)	Distance in Feet/SPL ¹ (dBA)					Nearest Receptor 4,200
				50 (adj.) ²	250	500	1,000	1,500	
Cherry Picker	10	16	81	83	69	63	57	53	45
Tractor	8	40	84	89	75	69	63	60	51
Forklift	6	40	86	90	76	70	64	60	51
Backhoe/Loader	8	40	78	83	69	63	57	54	45
Dozer	2	40	82	81	67	61	55	51	43
Flatbed Dump Truck	4	40	74	76	62	56	50	46	38
Water Pumps	8	50	81	87	73	67	61	57	49
Dump Truck	4	40	76	78	64	58	52	48	40
Generator	8	50	81	87	73	67	61	57	49
Crane	14	16	81	85	71	65	58	55	46
Flat Bed	5	40	74	77	63	57	51	47	39
Welder	25	40	74	84	70	64	58	54	46
Air Compressor	10	40	78	84	70	64	58	54	46
Pickup Trucks	30	40	75	86	72	66	60	56	47
Manlift	20	20	75	81	67	61	55	51	43
Composite Noise Level				97	83	77	71	67	58

Source: FHWA 2006.

¹ SPL = Sound pressure level.

² SPL adjusted to account for the % usage and quantity of equipment at 50 feet.

The estimated construction noise level of 58 dBA at the closest noise-sensitive receptor exceeds the EPA guideline of 55 dBA. These levels would occur temporarily over the course of construction; however, the L_{eq} 60 dBA for existing background level also exceeds the EPA guideline. As a temporary daytime occurrence, construction noise of this magnitude would likely be imperceptible, given the industrial setting. Therefore, the potential noise from site preparation and construction would result in negligible impacts.

The foundations for major pieces of equipment would overlay pile-driven reinforced-concrete piles, which would be installed using a combination of boring and impact pile-driving. The sound level of a typical impact pile driver installing piles is L_{max} 101 dBA at 50 feet (FHWA 2006). The construction noise model predicts a sound level contribution due to pile-driving operations of about 61 dBA at the nearest residential receptor, assuming two simultaneous pile driving operations at the closest edge of the site. The noise contribution from the pile-driving operations would result in a sound level of approximately 64 dBA at the nearest noise-sensitive receptor (a 3 dBA increase), which is expected to be barely perceptible. Although the noise levels from pile driving operation may exceed the EPA guidelines, the potential impacts are expected to be minor and temporary.

Traffic

Major construction components for the gasification plant such as the gasifier and other large or heavy items would arrive at the plant by barge or by rail, and conventional building supplies would arrive by truck. Construction vehicles would include concrete, asphalt, and delivery trucks and construction worker vehicles. The movement of construction equipment, materials, and construction workers would cause a temporary increase in traffic noise at a limited number of residences. However, as a temporary daytime occurrence, the increase in traffic noise may go unnoticed by many in the project area. Therefore, the potential noise from construction traffic would cause negligible impacts.

4.11.2.1.2 Off-site Activities

The proposed parking area for construction workers is located in an industrial area on a currently cleared and graded site. Noise levels in the area would increase for a short time during gravel unloading and spreading. There are no noise-sensitive receptors in the vicinity of the parking area. Therefore, noise at the construction parking area would result in no impacts.

Preparation of the equipment laydown area would involve equipment for clearing and grading. Construction-related noise levels at any given location would depend on the type and number of pieces of construction equipment being operated and the receptor's distance from the site. Once construction is complete, Leucadia would install sulfuric acid and methanol storage tanks on the area previously used as an equipment laydown area. The use of construction equipment would increase noise levels in the vicinity of the site during the installation of the storage tanks. The equipment laydown and storage tank location would be within an industrial area with no nearby noise receptors. Therefore, the potential noise from equipment laydown activities and construction of the sulfuric acid and methanol storage tanks would result in negligible impacts.

Construction activities in the existing right-of-way would include trenching, pipe stringing, welding, lowering in, backfilling, and restoration for the natural gas, potable water, electric transmission, sulfuric acid, and methanol linears. Equipment typically used for pipeline construction includes bulldozers, cranes, backhoes, semi-trucks, dump trucks, and pickup trucks. The linear routes are within an industrial area with no nearby noise receptors. The potential alternative route for the transmission line on the west side of Louisiana Pigment is also an industrial area with no nearby noise receptors. Therefore, the potential noise from construction would result in no impacts.

Construction of the water supply pipeline would be conducted using an assembly line method, moving in a sequential fashion, with activities limited at any single location to a relatively short

period. Construction activities include clearing and grading of the right-of-way, trenching, pipe stringing, welding, lowering in, backfilling, and restoration. Equipment typically used for pipeline construction includes bulldozers, cranes, backhoes, semi-trucks, dump trucks, and pickup trucks. At certain locations, and for limited time periods, drilling equipment may be used to install pipe. Other types of equipment typically used during construction include chain saws, bush hogs, pumps, generators, rotary trenching machines, welding equipment, and radiographic trucks.

Leucadia would conduct construction activities during daytime hours, except in areas where HDD technology would be required. Typical construction equipment would produce approximately 70 to 90 dBA at 50 feet (FHWA 2006). The loudest equipment would generally emit noise in the range of 80 to 90 dBA at 50 feet. Noise at any specific receptor would be dominated by the closest and loudest equipment and would vary over time. Construction equipment composite noise levels at various distances are presented in Table 4.11-4.

Table 4.11-4 Construction Noise from Typical Pipeline Construction Equipment and Activities

Construction Equipment	Quantity	Usage Factor %	L _{max} SPL @ 50 Feet (dBA)	Distance in Feet/SPL ¹ (dBA)				
				50 (adjusted) ²	250	500	1000	1500
Chainsaw	1	20	84	77	63	57	51	47
Bush Hog	2	40	84	83	69	63	57	53
Dozer	3	40	82	83	69	63	57	53
Trencher	4	50	80	83	69	63	57	53
Track-mounted Backhoe	5	40	78	81	67	61	55	51
Dump Truck	3	40	76	77	63	57	51	47
Pickup Truck	3	40	75	76	62	56	50	46
Flatbed Truck	7	40	74	78	64	58	52	49
Side Boom	8	16	85	86	72	66	60	57
Welder	9	40	74	80	66	60	54	50
Radiographic Truck	10	40	75	81	67	61	55	51
Composite Noise Level				92	78	72	66	62

Source: FHWA 2006.

¹ SPL = Sound pressure level.

² SPL adjusted to account for the % usage and quantity of equipment at 50 feet.

At traffic and water body crossings, drilling and related construction equipment would likely operate on a continuous, 24-hour-per-day basis over periods of time ranging from one to three weeks. Of the proposed techniques, including boring, span, and HDD, the HDD equipment produces the most noise. Table 4.11.5 summarizes typical HDD equipment noise characteristics. Currently, four HDD sites along the water supply pipeline route are planned. Table 4.11-6 presents Leucadia’s proposed locations for HDD crossings along the water supply pipeline, the distance to the nearest noise receptor, and the estimated noise levels at the receptors nearest to the entry and exit points of the drilling. Table 4.11-6 also identifies crossings where the EPA sound level guideline might be exceeded during HDD operations.

Table 4.11-5 Typical HDD Equipment for Pipeline Construction

Entry	Exit
Drilling rig and engine-driven hydraulic power unit	Backhoe, sideboom, backhoe and/or trucks
Engine-driven mud pump(s)	Engine-driven generator set
Engine-driven generator set(s)	Small engine-driven pump
Mud mixing/cleaning equipment and associated fluid systems shale shakers	Engine-driven light plants (used for nighttime operation)
Crane	
Engine-driven light plants (used for nighttime operation)	
Backhoe, frontloader, forklift, and/or truck(s)	
Frac tanks (i.e., water and drilling mud storage)	

Table 4.11-6 Estimated Sound Level Contribution of the Planned HDD Crossings for the Water Supply Pipeline

No.	Milepost	HDD Segment	Entry or Exit Point	Distance of Nearest NSAs (feet)	Exceeds Noise Guideline?	Level (Ldn) of HDD (dBA)
1	0.6 - 1.2	Bayou d'Inde	Entry	1,603	No	54.6
			Exit	4,245	No	33.4
2	2.2 - 2.3	PPG Road, Pete Manena Road	Entry	995	Yes	59.4
			Exit	821	No	51.1
3	3.3 - 3.4	Interstate 10	Entry	790	Yes	61.7
			Exit	655	No	53.3
4	3.7 - 4.2	Highway 90/East Napoleon Street	Entry	334	Yes	69.9
			Exit	923	No	50.0

The proposed water supply pipeline route passes through sparsely populated areas. However, a church on East Burton Street is within 50 feet of the construction right-of-way. In some cases, it may be necessary to conduct HDD activities within 165 feet of a residence or noise sensitive area between sunset and sunrise Monday through Saturday, or between 9 p.m. and 8 a.m. on Sundays and holidays. Operating construction equipment at this distance and during these times is prohibited by the Calcasieu Parish ordinance. If such a situation arises, a variance may be required.

The hydrogen pipeline would be constructed in the same manner as the raw water supply line described above. Table 4.11-7 presents Leucadia's proposed locations for HDD crossings along the hydrogen pipeline, the distance to the nearest noise receptor, and the estimated noise level at the receptors nearest to the entry and exit point of the drilling. Table 4.11-7 also identifies crossings where the EPA sound level guideline might be exceeded during the HDD operations.

Table 4.11-7 Estimated Sound Level Contribution of the HDD Crossings for the Hydrogen Pipeline

No.	Milepost	Segment	Entry or Exit Point	Distance of Nearest NSAs (feet)	Exceed Noise Guideline?	Level (L _{dn}) of HDD (dBA)
1	0.1 - 0.6	Leucadia Plant, City of Sulphur WWTP, LA Pigment	Entry	3,109	No	47.3
			Exit	1,438	No	45.5
2	1.7 - 2.3	Bayou D'Inde, Bayou D'Inde Tributary, Pipeline, and Rail	Entry	2,468	No	49.9
		Hwy 108/Cities Service Hwy	Exit	270	Yes	61.6
3	3.4 - 3.6	Swisco Road	Entry	140	Yes	77.8
			Exit	86	Yes	71.8
4	4.1 - 4.3	Bayou D'Inde	Entry	2,646	No	49.1
			Exit	2,875	No	38.0
5	4.5 - 4.9	Sabine River Canal	Entry	1,530	Yes	55.1
			Exit	140	Yes	67.5
6	5.2 - 5.9	Unnamed Tributary, S. Beglis Pkwy, Wright Street	Entry	495	Yes	66.2
			Exit	524	Yes	55.4
7	6.1 - 6.4	Mars Street, Ruth Street	Entry	285	Yes	71.4
			Exit	260	Yes	61.9
8	6.6 - 6.9	Unnamed Tributary, Carlyss Drive	Entry	375	Yes	68.8
			Exit	250	Yes	62.3
9	7.6 - 7.7	Currie Drive	Entry	1,200	Yes	57.6
			Exit	1,277	No	46.7

Leucadia would use minimization measures (e.g., sound barriers) as needed to achieve up to an approximately 10 dBA reduction in noise levels. Measures used to limit noise levels would include the following:

- Limit construction activities to daylight hours except as noted for drilling operations.
- Contractors would be required to employ general construction noise minimization measures and ensure all equipment is in good working order, adequately muffled, and maintained in accordance with the manufacturers' recommendations. Noise levels would be one of the factors considered during equipment and contractor selection.
- Semi-permanent stationary equipment (e.g., generators, lights), which may be available in "quiet" packages, would be stationed as far from NSAs as possible.
- Temporary barriers utilizing materials such as intermodal containers or frac tanks, plywood walls, mass-loaded vinyl (vinyl impregnated with metal), or hay bales would be constructed.

Although the noise levels from construction of the water supply and hydrogen pipelines may exceed the EPA and HUD guidelines, the potential impacts are expected to be minor and temporary.

4.11.2.2 Operation
4.11.2.2.1 Gasification Plant

The primary noise sources consist of the cooling towers, process compressors, steam turbine generators, flare, and major pump/motor assemblies. Secondary noise sources include exhaust fans, coolers, general pump/motor assemblies, chillers, and blowers. No project-specific sound level data is available for any of this equipment as the specific models and vendors have not yet been selected. Table 4.11-8 lists typical sound levels for this type of equipment.

Table 4.11-8 Typical Process Equipment Sound Levels

Equipment	Typical Sound Level
STG Package (Outdoors)	85 dBA @ 1 m ^a
STG Condenser (Outdoors)	85 dBA @ 1 m ^a
Cooling Tower	65 dBA @ 122 m ^b , 85 dBA @ 1 m ^a
Miscellaneous Pumps	90-92 dBA @ 1 m ^a
Recycle Gas Compressor	Lw = 102 dBA (casing)
	Lw = 105 dBA (inlet)
Propylene Refrigerant Compressor	Lw = 122 dBA (casing)
	Lw = 125 dBA (inlet)
CO ₂ Gas Compressor	Lw = 124 dBA (casing)
	Lw = 106 dBA (inlet)
Cooling Air Blower	Lw = 109 dBA
Booster Blower	Lw = 105 dBA
Weight Belt Feeder	85 dBA @ 1 m ^a

Source: ATCO 2012.

Notes:

- ^a Average sound pressure level along the equipment envelope.
- ^b The maximum sound pressure level in any direction from the equipment envelope at the distance specified.
 The equipment envelope is defined as the contour that completely encompasses all equipment components at a distance of 1 meter from the equipment face or enclosure.
- ^c Lw = Sound Power Level.

Leucadia calculated the equipment sound power level for the LCCE Gasification plant to achieve an overall sound level at the nearest noise-sensitive receptor that does not exceed 58 dBA, which is 5 dBA above the background L₉₀ of 53 dBA, but below the background L_{eq} of 60 dBA. The equipment sound power levels shown in Table 4.11-9 below are theoretical and use a correction for hemispherical distribution over distance. The far-field noise propagation can vary significantly, depending on the shape, size, and orientation of the new equipment. This calculation also does not include attenuation due to air absorption, ground effects, and other miscellaneous factors used in calculating equipment sound power levels.

Table 4.11-9 Equipment Sound Power Level Calculation for LCCE Gasification Plant to Achieve 58 dBA.

Receptor	Distance from Facility (feet)	Ambient Sound Level ^a (dBA)	Overall Sound Level ^b (dBA)	LCCE Gasification Facility Noise Contribution Level ^c (dBA)	Equipment Sound Power Level ^d (dBA)
3055 Bayou l'nde Road	4,200 feet	53	58	56	126

Notes:

- ^a Ambient sound level measured during the environmental noise survey.
- ^b Overall sound level includes the existing ambient sound level, i.e., overall sound level = ambient level + future facility noise contribution Level.
- ^c Future facility noise contribution level = overall sound level – ambient sound level.
- ^d Equipment sound power level (L_w) is calculated based on the formula $L_w = L_r + 10 \cdot \log(4 \cdot \pi \cdot r^2 / 2)$, where r is the distance of the far-field receiver point where L_r is measured.

No federal, state, or local noise regulations are applicable. However, Leucadia would implement design measures to limit the noise emissions from the LCCE Gasification plant such that the combination of noise from the plant and existing ambient noise would not exceed 58 dBA at the nearest noise-sensitive receptor during operation. Final design and selection of equipment would provide a basis for a more detailed noise evaluation. Upon final design, Leucadia would incorporate noise minimization measures such as sound enclosures, vent silencers, buffer zones, and would place equipment in strategic locations in order to limit any increase in noise over the existing ambient noise at the nearest receptors and limit the noise impact on the surrounding area. With the inclusion of these measures, sound levels would be reduced to 58 dBA at the nearest receptor (an increase of 5 dBA or less) and operation would result in negligible, long-term impacts on the nearest noise-sensitive receptor.

4.11.2.2.2 Off-site Activities

Operation of the methanol storage area would include periodic loading of transport vehicles with methanol and sulfuric acid and operation vehicles. Operation would result in negligible additional noise. Once constructed, operation of the utilities and linears would involve use of vehicles by inspection and maintenance workers. Noise impact during operation would be negligible. Operation of the raw water supply and hydrogen pipelines would not result in additional noise in areas along the pipeline route. Noise impacts from equipment and vehicles used during inspection and maintenance activities would be negligible.

4.11.3 Lake Charles CCS Project

4.11.3.1 CO₂ Capture and Compression Facilities Construction

Construction of the CO₂ capture and compression facilities would result in noise levels similar to those generated by construction of the LCCE Gasification plant; however, noise levels would be lower because there would be less construction equipment and shorter in duration. The overall construction of the LCCE Gasification plant includes construction of Lake Charles CCS project CO₂ capture and compression facilities. Because construction of the LCCE Gasification plant would result in a negligible noise impact at the nearest receptor locations, construction of the CO₂ capture and compression facilities also would also result in a negligible noise impact.

Operation

The primary noise sources would consist of the CO₂ compressors. Leucadia has not selected a vendor for this equipment and project-specific sound level data is not available. Typical sound

levels for CO₂ compressors are 124 dBA (casing) and 106 dBA (inlet) (ATCO 2012). Noise propagation calculations based on the typical sound levels resulted in a noise contribution of 49 dBA at the nearest receptor location due to the operation of the CO₂ compressors alone. The CO₂ compressor noise is included in the noise analysis for the LCCE Gasification plant (see section 4.11.2.2.1). Leucadia calculated the equipment sound power level for the gasification plant, including the CO₂ compressors, to achieve an overall sound level at the nearest noise-sensitive receptor that does not exceed 58 dBA, which is 5 dBA above the background of 53 dBA. Given the industrial setting and the small noise contribution from the CO₂ compressors to the overall facility noise, the noise from operation of the CO₂ capture and compression facilities would have negligible impacts on noise receptors in the vicinity of the site.

4.11.3.2 CO₂ Pipeline
4.11.3.2.1 Proposed Route

Construction

Construction of the CO₂ pipeline would proceed as described for the raw water pipeline in Section 4.11.2.1.2. Most of the proposed pipeline route passes through sparsely populated areas. Table 4.11-10 identifies the locations of residences within 50 feet of the construction right-of-way of the proposed CO₂ pipeline route. Hoover and Keith, Inc. conducted a noise impact assessment of HDD operations for the planned HDD sites that are within 0.5 miles of an NSA (H&K 2012). Because HDD operations may occur 24 hours per day, seven days per week, HDD operations could generate relatively high noise levels for long periods compared with conventional pipeline construction techniques.

Table 4.11-10 Commercial and Residential Areas within 50 Feet of the Construction Workspace of the Proposed CO₂ Pipeline

Residence	MP	Distance to ROW	Direction
Residence 1	4.3	45 feet	Northeast
Residence 2	5.5	40 feet	Northeast
Residence 3	5.5	40 feet	Northeast
Residence 4	5.5	38 feet	Northeast
Residence 5	5.6	48 feet	Northeast
Residence 6	10.3	35 feet	East
Residence 7	10.4	50 feet	East
Residence 8	10.8	50 feet	North

Table 4.11-11 summarizes the estimated sound level (L_{dn}) of drilling operations calculated from the estimated A-weighted sound level at the closest NSAs within 0.5 miles of either the HDD entry or HDD exit sites. Table 4.11-11 also identifies sites where the EPA sound level guideline might be exceeded during HDD operations.

Table 4.11-11 Estimated Sound Level Contribution of the Planned HDD Sites

No.	HDD Segment	Entry or Exit Point	Distance and Direction of NSA	Exceed Noise Guideline ¹	Level (L _{dn}) of HDD (dBA)	Ambient Level (L _{dn}) (dBA)	L _{dn} of HDD + Ambient (dBA)	Increase Above Ambient (dBA)
1	LA Pigment Plant HDD	Exit	1,250 feet (west)	No	46.5	58.2	58.5	0.3
2	Bayou d'Inde HDD	Entry	700 feet (WNW)	Yes	62.7	51.1	63.0	11.9
		Exit	1,150 feet (north)	No	46.2	51.3	52.5	1.2
3	Interstate 10 HDD	Entry	1,500 feet (NNW)	No	51.9	61.7	62.1	0.4
		Exit	600 feet (WSW)	No	52.6	50.5	54.7	4.2
4	Hwy 90/RR HDD	Entry	300 feet (NE)	Yes	70.8	59.8	71.1	11.3
		Exit	500 feet (SE)	No	54.3	59.8	60.9	1.1
5	Foreign Pipeline HDD	Entry	1,700 feet (NNW)	No	50.6	50.9	53.8	2.9
		Exit	1,400 feet (NW)	No	41.3	50.9	51.4	0.5
6	Sabine Canal HDD	Entry	600 feet (west)	Yes	61.2	52.8	61.8	9.0
		Exit	500 feet (NW)	No	54.3	51.1	56.0	4.9
7	Hardey Cemetery HDD	Entry	200 feet (east)	Yes	74.5	48.0	74.5	26.5
		Exit	200 feet (west)	Yes	64.2	52.3	64.5	12.2
8	Houston River HDD	Entry	300 feet (west)	Yes	72.2	49.0	72.3	23.3
		Exit	2,600 feet (SE)	No	34.7	46.3	46.6	0.3
10	High Hope Road HDD	Entry	150 feet (east)	Yes	77.1	45.0	77.1	32.1
		Exit	300 feet (NE)	Yes	60.5	41.9	60.5	18.6
11	Bankens Road HDD	Entry	150 feet (south)	Yes	77.1	44.9	77.1	32.2
		Exit	200 feet (south)	Yes	62.8	52.5	63.2	10.7

Source: H&K 2012.

¹EPA guideline level is L_{dn} of 55 dBA.

Denbury proposes to use appropriate minimization measures (e.g., sound barriers) as needed to achieve up to an approximately 10 dBA reduction in noise levels. Measures used to limit noise levels would include the following:

- Construction activities would be limited to daylight hours except as noted for drilling operations.
- Contractors would be required to employ general construction noise minimization measures and ensure all equipment is in good working order, adequately muffled, and maintained in accordance with the manufacturers' recommendations. Noise levels would be one of the factors considered during equipment and contractor selection.
- Semi-permanent stationary equipment (e.g., generators, lights), which may be available in "quiet" packages, would be stationed as far from sensitive areas as possible.
- Temporary barriers utilizing materials such as intermodal containers or frac tanks, plywood walls, mass-loaded vinyl (vinyl impregnated with metal), or hay bales may be constructed.

Noise levels may exceed the EPA guideline level of 55 dBA L_{dn} at some residences during pipeline construction and would generally not be considered acceptable on a permanent basis. In some cases, it may be necessary to operate HDD activities within 165 feet of a residence or noise sensitive area between sunset and sunrise Monday through Saturday, or between 9 p.m. and 8 a.m. on Sundays and holidays. Operating construction equipment at this distance and during these times is prohibited by the Calcasieu Parish and Cameron Parish ordinances. If such a situation arises, a variance may be required. Otherwise, as a temporary daytime occurrence, noise from construction of the CO₂ pipeline would have minor and temporary impacts on noise receptors in the vicinity of the pipeline.

Traffic

Construction of the CO₂ pipeline would cause only minor, short-term increases in traffic on the roadway system in the project area. Denbury would access the pipeline corridor primarily through the use of interstate, state, county, and local roads, and existing right-of-way corridor access roads. Local roads and existing right-of-way access roads would provide access for construction and operation along the length of the pipeline corridor. The movement of construction equipment, materials, and construction workers would cause a temporary increase in traffic noise along area roadways. However, the impacts from increased traffic noise would be negligible because a majority of the pipeline route traverses rural areas, and construction workers would be geographically dispersed during the construction period.

Operation

Once construction of the CO₂ pipeline has been completed, no noise above ambient levels would be generated by operation of the pipeline. Noise impacts from equipment and vehicles used during inspection and maintenance activities would be negligible.

4.11.3.2.2 Alternative Route B

Construction

The noise impacts from construction of the CO₂ pipeline along alternative route B would be similar to those of the proposed CO₂ pipeline route. Although most of the alternative route B pipeline lateral route passes through sparsely populated areas and industrial areas, approximately 10 residences are located within 50 feet of the route as compared with approximately eight along the proposed route. Noise levels are expected to exceed the EPA and HUD guidelines in some locations, but noise impacts would be minor and temporary.

4.11.3.3 West Hastings Research MVA

Noise producing equipment would include smaller re-work drilling rigs and ancillary equipment such as mud pumps during daytime hours. These activities would occur only during daytime hours. Ancillary equipment would be included in the drilling rig noise envelope. The expected noise levels were calculated based on the noise emission value usage factor for a drill rig truck contained in the Federal Highway Administration Highway Construction Noise Handbook published in 2006. The following logarithmic equation was used to compute projected noise levels:

$$Lp1 = Lp2 + 10\log(U.F.) - 20\log(d1/d2)$$

where:

Lp1 = the average noise level (dBA) at a noise sensitive receptor due to the operation of a unit of equipment throughout the day;

Lp2 = the equipment noise level (dBA) at a reference distance (d2);

U.F. = a usage factor that accounts for a fraction of time an equipment unit is in use throughout the day;

d1 = the distance from the receiver to the unit of equipment in feet;

d2 = the distance at which equipment noise level data is known (reference distance = 50 feet)

Table 4.11-12 summarizes the projected sound pressure levels at various distances from a truck-mounted drill rig. These calculations were conservative in that they did not include losses for intervening topography, ground absorption or atmospheric attenuation. These levels would occur temporarily over the course of well reworking activities; as a temporary daytime occurrence, construction noise of this magnitude would likely be imperceptible, given the industrial setting, and Denbury's on-going commercial EOR operations. Therefore, the potential noise from the West Hastings research MVA well reworking would result in negligible impacts.

Traffic noise may increase for additional periodic sampling and monitoring activities, but the increase would not be distinguishable from ambient noise levels and would be negligible.

Table 4.11-12 Noise from Drill Rig Truck at Various Distances

Equipment	Reference dBA @ 50 feet	Number of Devices	Usage Factor (percent)	Estimated L _{eq} Noise Level in dBA at the Specified Distance from the Source (feet)					
				50	100	250	500	1,000	2,500
Drill Rig Truck	84	1	20	77	71	63	57	51	43

Noise emission data and usage factor are from the FHWA Highway Construction Noise Handbook 2006
Equipment and operation noise levels are expressed in terms of L_{max} noise levels.
Reference: U.S. Department of Transportation, August 2006, FHWA Highway Construction Noise Handbook.

4.11.4 Summary of Impacts

Tables 4.11-13 and 4.11-14 present summaries of the noise impacts and minimization measures for the LCCE Gasification plant and the Lake Charles CCS project.

Table 4.11-13 Summary of Potential Noise Impacts and Minimization Measures for LCCE Gasification Plant and Off-site Activities

Potential Impacts	Minimization Measure(s)
<p>Construction: Minor Potential sound level assuming two simultaneous pile driving operations at edge of site during plant construction (64 dBA) exceeds EPA day-night average guideline L_{dn} of 55 dBA and ambient background L_{eq} of 60 dBA. Sound level expected to be barely perceptible due to industrial setting.</p> <p>Sound levels from construction of the hydrogen and water supply pipelines may exceed EPA and HUD guidelines. For the water supply pipeline, HDD activities may need to be conducted in the evening or weekends within 165 feet of a residence or noise sensitive area, which is prohibited by Calcasieu Parish ordinances without a variance.</p>	<p>During construction of the pipelines, Leucadia would minimize noise levels by limiting construction activities to daylight hours, as practicable, requiring contractors to minimize construction noise and maintain equipment in good working order, and utilizing temporary sound barriers.</p> <p>Leucadia would request a variance from Calcasieu Parish, if necessary, for operating HDD equipment during evening and weekend hours.</p>
<p>Operation: Negligible Leucadia equipment estimated sound level at nearest noise receptor would exceed the EPA L_{dn} of 55 dBA but would not exceed the ambient background L_{eq} of 60 dBA.</p>	<p>Leucadia would incorporate noise mitigation measures, such as sound enclosures, vent silencers, buffer zones, and strategic equipment placement, into the design to limit sound levels at the nearest receptor to 58 dBA.</p>

Table 4.11-14 Summary of Potential Noise Impacts and Minimization Measures for Lake Charles CCS Project

Potential Impacts	Minimization Measure(s)
Construction and Operation of the CO₂ Capture and Compression Facilities: Minor Included in the LCCE Gasification plant (see Table 4.11-13). The compressors contribute 49 dBA at the nearest receptor location.	Included in the LCCE Gasification plant (see Table 4.11-13)
Construction of the CO₂ Pipeline or Alternative Pipeline: Minor Sound levels may exceed EPA and HUD guidelines at some residences during pipeline construction. HDD activities may need to be conducted in the evening or weekends within 165 feet of a residence or noise sensitive area, which is prohibited by Calcasieu Parish and Cameron Parish ordinances without a variance.	During construction of the pipeline, Denbury would minimize noise levels by limiting construction activities to daylight hours, as practicable, requiring contractors to minimize construction noise and maintain equipment in good working order, and utilizing temporary sound barriers. Denbury would request a variance from Calcasieu Parish and Cameron Parish, if necessary, for operating HDD equipment during evening and weekend hours.
Operation of the CO₂ Pipeline or Alternative Pipeline : Negligible Noise would be generated from equipment and vehicles used during pipeline inspection and maintenance activities. Estimated sound levels would not exceed ambient levels during operation of the pipeline.	No minimization measures would be necessary.
Operation of the West Hastings research MVA program: Negligible Sound levels from operation of a small drill rig and supporting equipment would most likely be imperceptible due to industrial setting.	No minimization measures would be necessary.

4.12 Waste Management

4.12.1 Factors Considered for Assessing Impacts

DOE assessed the potential for impacts from waste management based on whether the proposed project or connected action would directly or indirectly:

- create wastes for which there are no commercially available disposal or treatment technologies;
- create hazardous wastes in quantities that would require a treatment, storage, or disposal permit under the Resource Conservation and Recovery Act (RCRA); or
- affect the capacity of hazardous or solid waste collection services and landfills.

This section analyzes the management of nonhazardous and hazardous wastes that could be generated during construction and operation of the LCCE Gasification plant and Lake Charles CCS project and their potential to enter the environment. To evaluate potential impacts, DOE considered the quantity and characteristics of wastes, applicable regulatory requirements, and the proposed design and operating plans.

Waste management is the process in which unwanted materials (or wastes) are collected, processed, transported, and disposed of or recycled. Wastes can be generated in many ways, and some wastes have strict regulations regarding their storage, transport, and disposal. Wastes fall into several categories, including solid, recyclable, nonhazardous, universal, and hazardous.

Hazardous waste refers to a class of wastes specifically defined by RCRA. These wastes are generated by certain listed processes or have certain characteristics (e.g., toxicity, reactivity, ignitability, or corrosivity) that cause them to be a significant risk to the environment and/or human health. RCRA requires that hazardous wastes be properly stored, transported, and disposed of at an EPA-permitted treatment, storage, and disposal facility (TSDF).

4.12.2 LCCE Gasification (Connected Action)

4.12.2.1 Construction

Section 2.4.1.2 describes the wastes that may be generated during construction, including construction debris, vegetation from site clearing, general office trash, and surplus construction materials such as timber, concrete, gravel, metals, plastics, and empty containers. Table 4.12-1 summarizes the construction waste streams and how they would be managed.

Table 4.12-1 Wastes Generated during Construction and Management Methods

	Management Method
Nonhazardous Wastes	
<ul style="list-style-type: none"> ■ Concrete, cinder blocks, drywall (sheetrock, gypsum, or plaster), masonry, asphalt and wood shingles, slate, and plaster ■ Forming and framing lumber, plywood, wood laminates, wood scraps, and pallets ■ Steel, stainless steel, pipes, rebar, flashing, aluminum, copper, brass, structural steel, and steel utility poles ■ Brick ■ Siding ■ Electrical wiring and conduit ■ Non-asbestos insulation ■ Wood, sawdust, brush, trees, stumps, earth, fill, rock, and granular materials ■ Treated wood, including lumber, posts, ties, decks, and utility poles 	Recycle, or dispose of at an off-site landfill
Potentially Hazardous Wastes	
<ul style="list-style-type: none"> ■ Waste paints, varnish, solvents, sealers, thinners, resins, roofing cement, adhesives, machinery lubricants, and caulk ■ Drums and containers that previously contained the items listed above ■ Used oil rags, used oil, spent cleaners, and used hydraulic oil from routine operation and vehicle maintenance 	Store on site for less than 90 days; dispose of at a hazardous waste disposal facility

Prior to the start of construction, Leucadia would require construction contractors to develop a Waste Management Plan (WMP), which would include specifications for collecting, labeling, handling, temporarily storing, and properly disposing of all wastes generated during construction. Leucadia would also implement a waste reduction, reuse, and recycling program to minimize waste generation during construction by reusing or recycling waste materials to the

extent practicable. Nonhazardous wastes that could not be reused or recycled would be periodically transported off-site by licensed contractors for disposal at local permitted solid waste landfills.

Potentially hazardous wastes that could be generated during construction include small quantities of waste paints, varnish, solvents, sealers, thinners, resins, roofing cement, adhesives, lubricants, and used oil. Potentially hazardous wastes would be properly collected, sampled, and characterized. Wastes listed or characterized as hazardous would be labeled, packaged, and temporarily stored in 55-gallon drums or other appropriate containers in a designated hazardous waste accumulation area. Permitted hazardous waste transporters would transport hazardous wastes that could not be recycled off site to the Waste Management Company's Lake Charles Hazardous Waste Facility in Sulphur, Louisiana, or to a similarly regulated TSDF for proper disposal, as shown in Table 3.12-1. The temporary storage and handling of hazardous or flammable wastes would be conducted in compliance with EPA and Occupational Safety and Health Administration (OSHA) regulations and the National Fire Protection Association's "Guide on Hazardous Materials" (NFPA 2010).

Off-site facilities associated with operation of the LCCE Gasification plant are described in Section 2.3.1. Construction of the off-site facilities would occur as part of construction of the LCCE Gasification plant and would include the construction of pipelines. The HDD construction method, described in Section 4.4, would be used to construct portions of the pipelines associated with LCCE Gasification. During the HDD operations, a nonhazardous bentonite slurry would be used as a drilling fluid. Following HDD operations, the bentonite slurry would be recycled, spread in upland areas as a soil supplement, if permitted, or removed from the HDD site and disposed of in local permitted solid waste landfill.

Assuming no recycling of construction wastes (in order to estimate the maximum effect of waste), approximately 2,640 cubic yards of nonhazardous waste and small quantities of hazardous waste would be generated annually during the three year construction period, or less than 0.0002% of the available landfill capacity in Calcasieu Parish. The nonhazardous and potentially hazardous wastes generated during construction would be typical of industrial facilities and would not require the use of disposal or treatment technologies that are not commercially available. Construction would not create hazardous wastes in quantities that would require a RCRA permit. Contractors permitted to collect and properly dispose of hazardous wastes would transport the wastes to the Waste Management Company's EPA permitted Lake Charles Hazardous Waste Facility. Nonhazardous and potentially hazardous wastes generated from construction would have a negligible impact on the capacity or management of hazardous or solid waste services and landfills in the area.

4.12.2.2 Operation

As described in Section 2.5.1.2, the proposed project and connected action include complex industrial systems that would generate nonhazardous and potentially hazardous wastes. Table 4.12-2 lists the typical wastes that would be generated annually during operation of the gasification plant and how they would be managed.

Table 4.12-2 Wastes Generated during Operation and Management Methods (annual unless otherwise stated)

Waste Material	Quantity ¹	Management Method
Office wastes	100 yd ³	Landfill disposal
Gasifier slag	63,000 tons	Sale, recycle, or landfill disposal
Air filters for ASU	< 4,000 ft ³	Landfill disposal
Spent ASU molecular sieve and activated alumina	<1000 ft ³	Landfill disposal
Spent catalyst	<10,000 ft ³	Store on site less than 90 days; regeneration or disposal in a hazardous waste landfill
Water treatment sludge (from treating river water)	<2,000 tons	Landfill disposal
Zero liquid discharge system solids	365 tons	Landfill disposal
Used oil, oily rags	< 55 gallons per month	Store on site less than 90 days; recycle or disposal in a hazardous waste landfill
Universal Wastes, including mercury containing equipment, light bulbs, batteries,	Various	Store on site less than 90 days; recycle or disposal in a hazardous waste landfill

¹ The annual production quantities are based on estimated capacity factor and availability.

Key:

- ASU = Air separation unit
- ft³ = cubic feet
- yd³ = cubic feet

The primary solid waste stream generated during operation is nonhazardous slag, which is formed in the gasifier at temperatures above the melting point of the feed materials. The solid slag would consist of a wide range of particle sizes and would include some unreacted carbon. Leucadia would sell the slag as a nonhazardous by-product to various commercial markets, or the slag would be transported off site by licensed contractors for disposal at local permitted solid waste landfills.

Activated alumina adsorbents would be used in the air separation unit to dry and purify process gases. In its unused state, activated alumina is considered nonhazardous for purposes of disposal. However, the adsorbed material that is deposited on the spent adsorbent may change the classification for purposes of disposal; thus, the spent activated alumina could potentially be considered hazardous waste. Leucadia would characterize the spent activated alumina prior to disposal.

Catalysts are used in the AGR, the methanation process, the wet sulfuric acid process, and for NOx emission controls. Spent catalysts could be characterized as hazardous wastes because they typically contain oxides of heavy metals such as vanadium and titanium. Approximately 10,000 cubic feet of potentially hazardous spent catalysts would be generated annually. The spent catalysts may be regenerated for further use or characterized for proper disposal.

Leucadia would implement a zero liquid discharge (ZLD) system to treat the gasification process wastewater. ZLD processes concentrate the minerals and metals present in raw water and process wastewater and uses evaporation and crystallization to separate out the solids and recycle

the liquid stream. Solids generated from the ZLD process are estimated to be approximately 2,000 pounds per day, or 365 tons per year. Leucadia would test the ZLD solids prior to disposal to determine if they would be characterized as a hazardous waste. Assuming that the ZLD solids would be characterized as hazardous, the LCCE Gasification plant would exceed the 1,000 kilogram (2,200 pound) per month threshold and would be considered a Large Quantity Generator (LQG) of hazardous wastes under 40 CFR 260.10.

During operation, nonhazardous wastes would be generated periodically from ground cover mowing, vegetation clearing, and maintenance activities required to maintain the methanol and sulfuric acid pipeline ROW and storage tank area in a condition suitable for pedestrian or vehicular access. Vegetation cut along the pipeline ROW during long-term routine maintenance would likely be reused as mulch or compost on ROW property and would not require landfilling.

No disposal of nonhazardous or hazardous wastes would occur at the LCCE Gasification plant site. Leucadia would implement a program to reduce, reuse, and recycle waste materials to the extent practicable. Nonhazardous wastes would be transported by licensed contractors to a permitted solid waste landfill in Calcasieu Parish for disposal. All universal wastes, including light bulbs and batteries, would be collected, labeled, recycled, and properly disposed of to prevent breakage and leaks to the environment. During operation, Leucadia would store and manage all materials and wastes in accordance with applicable legal requirements and BMPs, including appropriate containment, curbing, routine spill inspections, and, where applicable, compliance with SPCC plan and SWPPP requirements. Hazardous and nonhazardous wastes would be accumulated on-site in designated areas for less than 90 days. Hazardous wastes would be transported by licensed contractors for disposal at a permitted facility, such as the Waste Management Company's Lake Charles Hazardous Waste Facility in Sulphur, Louisiana, or a similarly regulated facility.

The nonhazardous wastes generated during operation would be typical of industrial facilities and would not require the use of unique disposal or treatment technologies that are not commercially available. Assuming that no recycling would occur, the 65,000 tons (75,000 cubic yards) of nonhazardous waste generated annually during operation represents 0.6% of the total landfill capacity in Calcasieu Parish and would have a negligible impact on the capacity or management of solid waste services and landfills in the area.

The potentially hazardous wastes generated during operation would be typical of industrial facilities and would not require the use of disposal or treatment technologies that are not commercially available. Hazardous wastes would be stored in designated accumulation areas on site for periods less than 90 days, and a RCRA permit for the treatment, storage, or disposal of hazardous waste would not be required. Licensed contractors would transport hazardous wastes to the Waste Management Company's Lake Charles Hazardous Waste Facility in Sulphur, Louisiana, or to a similarly regulated facility for proper disposal. Approximately 1,500 cubic yards of potentially hazardous waste would be generated annually during operation, or less than 0.03% of the capacity of the hazardous waste landfills in Calcasieu Parish, and would have a negligible impact on the capacity or management of hazardous or solid waste services and landfills in the area.

4.12.3 Lake Charles CCS Project

4.12.3.1 CO₂ Capture and Compression Facilities

Construction of the CO₂ capture and compression facilities would occur as part of construction of the LCCE Gasification site. Wastes generated by construction of the CO₂ capture and compression facilities would be similar to those described above for the LCCE Gasification plant. Operation of the CO₂ capture and compression facilities would occur as part of operation of the LCCE Gasification plant. Operation of the CO₂ capture and compression facilities would generate one or two large-canister oil filters, which would be changed annually, and 500 to 1,000 gallons of used console oil, which would be replaced every 3 years and recycled at a permitted waste oil recycling facility or properly disposed of at an EPA-permitted TSDF.

4.12.3.2 CO₂ Pipeline

4.12.3.2.1 Proposed Route

Construction

Wastes associated with construction of the pipeline would primarily consist of land-clearing waste and drilling muds from HDD, construction mats and scrap, packaging materials, and general refuse (e.g., trailer office materials and debris from employees). Potential hazardous wastes associated with construction include sandblast abrasives (depending on use and type), paint thinner, and various solvents. To dispose of hazardous wastes generated during construction of the proposed CO₂ pipeline, Denbury would use permitted contractors to transport the wastes to an EPA-permitted TSDF.

Routine operation and vehicle maintenance during pipeline construction activities would also generate hazardous wastes including used oil rags, used oil, spent cleaners, and used hydraulic oil. These wastes would be collected in appropriate containers for transport to a permitted waste oil recycling facility or would properly disposed of at an EPA-permitted TSDF.

Portions of the CO₂ pipeline would be constructed using HDD. During the HDD operations, a nonhazardous bentonite slurry would be used as a drilling fluid. Following HDD operations, the bentonite slurry would be recycled, spread in upland areas as a soil supplement, if permitted, or removed and disposed of at a local permitted solid waste landfill.

Denbury requires that pipeline construction contractors develop a Waste Management Plan (WMP), including specifications for handling, containment, and disposal of all wastes generated during construction. Construction contractors would characterize wastes and determine the locations for hazardous materials storage areas, if needed, within designated areas. Denbury would maintain any such storage areas in accordance with applicable federal, state, and local regulations (Denbury 2008).

Nonhazardous and potentially hazardous wastes generated during construction would be typical of pipelines and would not require the use of disposal or treatment technologies that are not commercially available. Construction would not create hazardous wastes in quantities that would require a RCRA permit. Disposal of nonhazardous and potentially hazardous wastes generated by construction of the proposed CO₂ pipeline would have a negligible impact on the capacity or management of hazardous or solid waste services and landfills in the area.

Operation

During operation of the CO₂ pipeline, wastes would be generated occasionally from clearing activities required to maintain the ROW in a condition suitable for vehicular access. Following construction, no permanent O&M facility would be constructed, maintained, or staffed as part of the CO₂ pipeline. Waste generation would be limited to periodic ROW maintenance activities. Maintenance activities in pipeline corridor ROWs would typically require mowing of ground cover, clearing of vegetation, maintenance of access and service roads, and servicing and monitoring of pipeline system components.

During pipeline operation, materials and chemicals would not be stored along the pipeline ROW. Denbury would implement their waste management guidelines described in the *Waste Management/Minimization Plan* during routine maintenance. Any necessary materials required for maintenance and monitoring of pipeline systems and components would be transported into the pipeline ROW and used at the work site as needed. Materials would not be stored within the pipeline ROW. Vegetation cut along the pipeline corridor during long-term routine maintenance would likely be reused as mulch or compost on ROW property, if agreed to by the landowner, and would not require landfilling.

Nonhazardous and potentially hazardous wastes generated during routine maintenance operations of the pipeline would be typical of pipelines and would not require the use of unique disposal or treatment technologies. Operation of the pipeline would have a negligible impact on the capacity or management of hazardous or solid waste services and landfills in the area and would not create hazardous wastes in quantities that would require a RCRA permit for treatment, storage, or disposal.

4.12.3.2.2 Alternative Route B

The nonhazardous construction debris and potentially hazardous waste that would be generated by construction of the CO₂ pipeline along the alternative pipeline route would be similar to that described in Section 4.12.4 for construction and operation of the proposed pipeline route. Construction and operation of the alternative pipeline route would not generate different types of nonhazardous or hazardous waste.

4.12.3.3 West Hastings Research MVA

As described in Section 2.4.3, research MVA activities would involve drilling equipment to plug back, recondition, and re-complete existing wells. MVA activities could generate waste streams, including drilling mud and produced water during well construction.

Produced water and light sediment would be pumped into trucks and hauled off-site by a licensed contractor for disposal. Excess drilling mud would be collected and stabilized in steel tanks and transported off-site to a designated local solid waste landfill.

Denbury currently operates their commercial EOR activities under their waste management guidelines described in the *Waste Management/Minimization Plan*, which identifies the responsibilities, actions to be taken, and resources that would be applied and could be drawn upon for managing waste streams resulting from oil field operations and well drilling and reconversion/reconstruction activities.

No hazardous waste would be generated as a result of the West Hastings research MVA activities. Impacts related to the disposal of drill cuttings and treatment of the produced water generated during the reworking of existing wells would not require the use of unique waste disposal or treatment technologies and would result in negligible impacts on the capacity or management of landfills or disposal facilities in the area.

4.12.4 Summary of Impacts

Tables 4.12-3 and 4.12-4 present summaries of the waste impacts and minimization measures for the LCCE Gasification plant and the Lake Charles CCS project.

Table 4.12-3 Summary of Potential Waste Impacts and Minimization Measures for LCCE Gasification Plant and Off-site Activities

Potential Impacts	Minimization Measure(s)
<p>Construction: Negligible Assuming no recycling of construction waste, approximately 2,640 cubic yards of nonhazardous waste and small quantities of hazardous waste would be generated annually during the 3-year construction period, or less than 0.0002% of the available landfill capacity in Calcasieu Parish.</p>	<p>Leucadia would require construction contractors to develop a Waste Management Plan (WMP), which would include specifications for handling, containment, and disposal of all wastes generated during construction. Leucadia would also implement a program to reduce, reuse, and recycle waste materials to the extent practicable. Nonhazardous wastes would be transported by licensed contractors for disposal at a permitted solid waste landfill in Calcasieu Parish. Hazardous wastes would be accumulated in designated areas on site for less than 90 days and then transported to a permitted disposal facility.</p> <p>Following HDD operations, drilling muds would be spread in upland areas as a soil supplement, if permitted, or removed from the HDD site and disposed of in approved landfills.</p>
<p>Operation: Negligible Assuming no recycling, approximately 65,000 tons (75,000 cubic yards) of nonhazardous waste generated annually during operation represents 0.6% of the total landfill capacity in Calcasieu Parish. Approximately 1,500 cubic yards of potentially hazardous waste would be generated annually during operation, or less than 0.03% of the capacity of the hazardous waste landfills in Calcasieu Parish.</p>	<p>During operation, Leucadia would store and manage wastes in accordance with applicable regulatory requirements and BMPs, including appropriate containment, curbing, routine spill inspections, and, where applicable, compliance with SPCC Plan and SWPPP requirements. Nonhazardous wastes would be transported by licensed contractors for disposal at a permitted solid waste landfill in Calcasieu Parish. Hazardous wastes would be accumulated in designated areas on site for less than 90 days and then transported to a permitted disposal facility.</p>

Table 4.12-4 Summary of Potential Waste Impacts and Minimization Measures for Lake Charles CCS Project

Potential Impacts	Minimization Measure(s)
<p>Construction and Operation of the CO₂ Capture and Compression Facilities: Negligible Included in the LCCE Gasification plant (see Table 4.12-3)</p>	<p>Included in the LCCE Gasification plant (see Table 4.12-3)</p>
<p>Construction of the CO₂ Pipeline or Alternative Pipeline: Negligible Following HDD operations, the bentonite slurry would be recycled, spread in upland areas as a soil supplement, if permitted, or removed and disposed of at a local permitted solid waste landfill.</p>	<p>Denbury would require that pipeline construction contractors develop a Waste Management Plan (WMP), which would include specifications for handling, containment, and disposal of all wastes generated during construction. Construction contractors would characterize wastes and determine the locations for hazardous materials storage areas, if needed, within designated areas.</p>
<p>Operation of the CO₂ Pipeline or Alternative Pipeline: Negligible Waste generation would be limited to periodic ROW maintenance activities including mowing of ground cover, clearing of vegetation, maintenance of access and service roads, and servicing and monitoring of pipeline system components.</p>	<p>During operation and routine maintenance, Denbury would implement their waste management guidelines described in the <i>Waste Management/Minimization Plan</i>. During pipeline operation, materials and chemicals would not be stored along the pipeline ROW.</p>
<p>Operation of the West Hastings research MVA program: Negligible Produced water and light sediment would be pumped into trucks and hauled off site by a licensed contractor for disposal. Excess drilling mud would be collected and stabilized in steel tanks and transported off site to a designated local solid waste landfill per Denbury's current operating practices.</p>	<p>Denbury currently operates their commercial EOR activities under their waste management guidelines described in the <i>Waste Management/Minimization Plan</i>. Produced water and light sediment would be pumped into trucks and hauled off site for disposal by a licensed contractor. Excess drilling mud would be collected and stabilized in steel tanks and spread in upland areas as a soil supplement or transported off site to a designated local solid waste landfill.</p>

4.13 Materials

4.13.1 Factors Considered for Assessing Impacts

DOE assessed the potential for impacts on materials based on whether the proposed project or connected action would directly or indirectly:

- require materials not regionally available;
- cause new sources of construction materials and operational supplies to be built such as new mining areas, processing plants, or fabrication plants;
- affect the capacity of existing material suppliers and industries in the region; or
- release a hazardous material during normal operation.

This section analyzes the material required for construction and operation of the proposed project and connected action. Construction and operation of the project would require construction materials, construction equipment, process-related chemicals and materials, and access to markets for material required for and by-products generated during operation.

DOE assessed potential impacts by comparing the demands created by construction and operation of the proposed project and connected action to the capacities of construction and process materials suppliers and by-product consumers in the region. DOE also analyzed proposed operations and materials use, generation, and storage with respect to applicable federal, state and local regulations to evaluate the impacts of a release of a hazardous material during construction and normal operations. The risk of accidental releases is evaluated in Section 4.15.

4.13.2 LCCE Gasification (Connected Action)

4.13.2.1 Construction

As discussed in Section 2.4.1.1, the majority of the construction materials would consist of concrete, wood, fuel, and steel. Construction materials and specialized construction equipment are readily available from in-state vendors and fabricators with additional regional vendors as necessary. Locally obtained materials would include crushed stone, sand, and lumber for the proposed facilities and temporary structures (e.g., enclosures, forms, and scaffolding). Conventional building supplies would be delivered by truck. Components of the facilities would also include concrete, ductwork, insulation, electrical cable, lighting fixtures, and transformers. Materials would be shipped from their point of origin by various means, including, rail, truck, barge, and blue-water (ocean-going) ship. Major system components are described in Section 2.3.1.1. These components would be transported from international locations via ocean-going vessels and delivered to the Port of Houston or the Port of New Orleans. Barges would transport equipment from the ports through the Intracoastal Waterway or the Gulf of Mexico into the Calcasieu River Ship Channel to be offloaded at the LCCE Gasification plant site.

Hazardous substances including lubricants, transmission fluids, oils, etc. for the operation and maintenance of vehicles and construction equipment would be used and stored at the plant site and equipment laydown area. Small amounts of materials and oil products may spill as a result of equipment failure (split hydraulic lines, broken fittings) or human error (overfilled tanks).

Construction security fencing would restrict access to the plant site and equipment laydown area. Materials and equipment would be stored at the gasification plant or at the equipment laydown area during construction in secure locations with secondary containment, as appropriate.

OSHA Construction Industry Standards defined in 29 CFR 1926 include provisions for health and safety during construction including regulations intended to reduce the risk of releases of hazardous substances that could pose threats to employees. The OSHA Hazard Communication standard (29 CFR 1910.1200) addresses the issue of classifying the potential hazards of chemicals, and communicating information concerning hazards and appropriate protective measures to employees. The standard requires employers to provide information to their employees about the hazardous chemicals to which they are exposed on a routine basis.

Federal and state regulations applicable to construction are designed to reduce the risk of releases of hazardous substances to the environment. EPA requires facilities storing or using more than 1,320 gallons of oil in aboveground bulk storage tanks to develop SPCC plans to prevent spills

and respond accordingly in the case of a spill (40 CFR 112). LDEQ also requires sites with aboveground storage tanks containing over 600 gallons of oil or hazardous materials to prepare Spill Prevention and Control (SPC) plans to prevent and control the release of oil and hazardous materials resulting from spill events during construction and operation of facilities. The Louisiana State Fire Marshal regulates the installation of bulk atmospheric storage tanks used to store flammable and combustible liquids in accordance with National Fire Protection Association (NFPA) 30: Flammable and Combustible Liquids Code.

Leucadia would require construction contractors to provide a plan and a schedule for acquisition and storage of construction materials. The contractor would provide for adequate storage of materials (e.g., fuel, lubricants, transmission fluids, oils) necessary for the operation and maintenance of equipment and vehicles at the work sites. Hazardous materials would be stored in secondary containment and would be stored in a manner to minimize the potential for storm water contact. Leucadia would also maintain a safety program to minimize incidents and lost time injuries, and to protect the public complying with OSHA's excavation safety standards.

To minimize the potential for releases of oil products, solvents, and hazardous materials, Leucadia would implement a hazardous materials management plan, including the procedures to handle, store, transfer, and dispose of each material used or generated during construction. Qualified individuals would be trained in the management of hazardous materials and appropriate spill kits would be present at each work site. Leucadia would transfer materials and refuel vehicles in designated locations equipped with curbing or secondary containment. During construction, the storage and handling of toxic or flammable materials would be conducted in compliance with EPA and OSHA regulations and the NFPA's "Fire Protection Guide to Hazardous Materials."

In addition, Leucadia would obtain an Storm Water General Permit Associated with Construction Activity from the LDEQ and prepare SPCC, SWPPP, and SPC plans in accordance with applicable regulations to minimize the risk of release of oil, oil products, and hazardous materials.

New sources of construction materials would not be required to support the project. Construction material and equipment vendors are located in the region and support the many existing refineries, chemical plants, and heavy industrial facilities located in the Lake Charles area. Most construction materials should be available within 60 miles of the plant site. Some specialized equipment may require sourcing nationally; however, it is expected that this equipment would be readily available. As a result, the impact to construction material resources and suppliers would be negligible.

Leucadia would store and manage potentially hazardous materials in accordance with all applicable manufacturer and regulatory requirements and BMPs, including appropriate containment, curbing, routine spill inspections, and compliance with their SPCC, SWPPP, and SPC requirements. As a result, construction would include measures to decrease the potential for release of a hazardous material to the environment. Impacts of small spills during construction would be temporary and minor.

4.13.2.2 Operation

Section 2.5.1.2 provides a description of resources that are consumed during operation. Petcoke would be the primary material purchased for production of methanol and hydrogen. The petcoke feedstock purchased by Leucadia would primarily originate from the Gulf Coast region, which produces approximately 58% of the U.S. petcoke supply. Table 4.13-1 provides a summary of the chemicals and materials; the quantity used, stored, or generated; whether the material has a threshold quantity for evaluation of risks of releases; its physical phase, and the type of secondary containment proposed. Products that would be generated during operation are described in Section 2.5.1.2 and summarized in Table 4.13-2 below.

During operation, diesel fuel, gasoline, and bulk lubricants would be stored in small ASTs within secondary containment systems that would contain at least 110% of the volume of the largest AST within the secondary containment system. Small amounts of specialty nonhazardous lubricants would be stored in smaller containers. There would be small amounts of paints, cleaners, adhesives, and other chemicals in spray cans stored on site for normal maintenance of heavy equipment. Small quantities of paint could be kept on site in pint, quart, gallon, or 5-gallon cans. Spray cans of paints and cleaners would be kept in fireproof cabinets and would be completely used and decanted prior to disposal.

Federal and state regulations applicable to operation are designed to reduce the risk of releases of hazardous substances to the environment from storage and handling of materials. EPA’s SPCC and LDEQ SPC requirements would require development of plans to prevent and control the release of oil and hazardous materials resulting from spill events during operation.

Table 4.13-1 Resource Consumption and Storage Capacity During Operation of the LCCE Gasification Plant

Chemical Name	CAS No.	Annual Quantity Consumed	Storage Capacity	EPA Risk Management Program Threshold Quantity (lbs.)	Physical State	Secondary Containment
Petcoke		2,600,000 tons	390, 000 tons	Not Applicable	Solid	Curbing and enclosed bins
Fluxant		73,000 tons		Not Applicable	Solid	Curbing or enclosed silos
Aqueous Ammonia (19% Ammonia Hydroxide)	7664-41-7	252,000 gallons	33,000 gallons (2 tanks)	Not Applicable	Liquid	Containment; 120% capacity
Fuel (vehicles and equipment)		63,800 gallons	Various	Not Applicable	Liquid	Various, curbing
Chlorine	7782-50-5	varies, depending on water quality	10000 pounds (5 cylinders 2000 lbs. each)	2,500	Gas	Enclosed building with exhaust scrubber

Table 4.13-2 Products Generated During Operation of the LCCE Gasification Plant

Chemical Name	CAS No.	Quantity Generated	Storage Capacity	EPA Risk Management Program Threshold Quantity (lbs.)	Physical State	Secondary Containment
Hydrogen (99%)	1333-74-0	119 MSCF per day	N/A	10,000	Gas	Not Applicable
Carbon dioxide (CO ₂)		5.2 M TPY	N/A	Not Applicable	Gas	Not Applicable
Methanol	67-56-1	1.5 M TPY	Onsite 9.6 million gallons (Six 1.6 million gallon tanks)	Not Applicable	Liquid	Containment berm; 120% capacity
			Off-site 30.3 million gallons (Four 7.5 million gallon tanks)	Not Applicable	Liquid	Containment berm; 120% capacity
Sulfuric Acid	7664-93-9	421,000 Tons	3.3 million gallons (Six 550,000 gallon tanks)	10,000	Liquid	Containment berm; 110% capacity
			3.8 million gallons (Two 1.9 million gallon tanks)	10,000	Liquid	Containment berm; 110% capacity

The use, handling, and generation of hazardous materials are primarily regulated by OSHA and the EPA. The EPA Chemical Accident Prevention Provisions in 40 CFR 68 provide standards and guidance for accident prevention at facilities using substances that pose risks of harm to the public from accidental releases. The regulations require owners and operators of stationary facilities that produce, handle, process, distribute, or store certain chemicals to develop a Risk Management Program, prepare a Risk Management Plan (RMP), and submit the RMP to EPA to prevent accidental releases and minimize the consequences of releases should they occur. The RMP includes a(n):

- Hazard assessment that details the potential effects of an accidental release, an accident history of the last five years, and an evaluation of worst-case and alternative accidental releases scenarios;
- Prevention program that includes safety precautions and maintenance, monitoring, and employee training measures; and
- Emergency response program that spells out emergency health care, employee training measures and procedures for informing the public and response agencies should an accident occur.

The RMP Program must be developed and submitted to LADEQ prior to operation and must be updated and resubmitted at least once every 5 years. As shown in Table 4.13-1, chlorine and sulfuric acid would be stored in quantities that exceed the threshold quantity for USEPA’s RMP

rule. Leucadia would develop and implement an RMP, including a management system, hazard assessment, prevention plan, and emergency response program.

The OSHA Process Safety Management (PSM) standard, found in 29 CFR 1910.119, emphasizes the management of hazards associated with hazardous materials and establishes a comprehensive management program that integrates technologies, procedures, and management practices. PSM establishes a set of procedures in thirteen management areas that are designed to protect worker health and safety in case of accidental releases of hazardous substances. Similar to EPA's rule, OSHA PSM applies to a range of facilities that have more than a threshold quantity of a listed substance in a process. OSHA's applicability thresholds are sometimes different than the thresholds in the EPA RMP program. For example, the OSHA threshold for chlorine is 1,500 pounds and the EPA threshold quantity for chlorine is 2,500 pounds. OSHA PSM covers aqueous ammonia at a concentration of greater than 44 percent, whereas EPA covers aqueous ammonia at 20 percent or greater. PSM requires facilities that are subject to the standard to:

- Develop and maintain written safety information identifying workplace chemical and process hazards, equipment used in the processes, and technology used in the processes;
- Perform a workplace hazard assessment, including, as appropriate, identification of potential sources of accidental releases, an identification of any previous release within the facility which had a likely potential for catastrophic consequences in the workplace, estimation of workplace effects of a range of releases, estimation of the health and safety effects of such a range on employees;
- Consult with employees and their representatives on the development and conduct of hazard assessments and the development of chemical accident prevention plans and provide access to these and other records required under the standard;
- Establish a system to respond to the workplace hazard assessment findings, which shall address prevention, mitigation, and emergency responses;
- Periodically review the workplace hazard assessment and response system;
- Develop and implement written operating procedures for the chemical process including procedures for each operating phase, operating limitations, and safety and health considerations;
- Provide written safety and operating information to employees and train employees in operating procedures, emphasizing hazards and safe practices;
- Ensure contractors and contract employees are provided appropriate information and training;
- Train and educate employees and contractors in emergency response in a manner as comprehensive and effective as that required by the regulation promulgated pursuant to section 126(d) of the Superfund Amendments and Reauthorization Act;

- Establish a quality assurance program to ensure that initial process-related equipment, maintenance materials, and spare parts are fabricated and installed consistent with design specifications;
- Establish maintenance systems for critical process-related equipment including written procedures, employee training, appropriate inspections, and testing of such equipment to ensure ongoing mechanical integrity;
- Conduct pre-start-up safety reviews of all newly installed or modified equipment;
- Establish and implement written procedures to manage change to process chemicals, technology, equipment and facilities; and
- Investigate every incident which results in or could have resulted in a major accident in the workplace, with any findings to be reviewed by operating personnel and modifications made if appropriate.

Leucadia would implement a variety of prevention and mitigation measures to prevent and control releases of hazardous materials including the development of:

- Hazardous Materials Handling, Usage and Storage Plan
- OSHA Process Safety Management Program
- EPA Risk Management Plan
- Emergency Response Plan
- Fire Prevention and Protection Program
- Safety and Compliance Audits

Leucadia would store and handle toxic or flammable materials in compliance with EPA and Occupational Safety and Health Administration (OSHA) regulations and the National Fire Protection Association's "Guide on Hazardous Materials." Storage tanks for all chemicals would be designed of compatible materials with safety systems installed and maintained, including emergency shutdown (ESD) shutoff valves. To minimize potential release of a hazardous material, Leucadia would perform transfers of potentially hazardous liquid materials to storage tanks located within concrete process areas with curbing and a secondary containment system that would allow liquid released from leaks or spills to be recovered and recycled or properly disposed of. All above ground storage tanks (ASTs) would be located in secondary containment to contain the 10-year, 24-hour rainfall event and spillage from leaks. ASTs would be inspected by staff routinely for leaks, corrosion, and other maintenance requirements in accordance with a site-specific SPCC Plan.

Fire protection systems would be installed to extinguish any fire and limit the scope for escalation of incidents. Leucadia's operating plans include an integrated approach to controlling the risks of methanol releases and fires including fire and gas detection, ESD, blow-down, active fire protection and fireproofing. Methanol storage areas would be equipped with appropriate fire suppression systems.

Leucadia's training program would include training on proper material handling and spill response procedures. Small spills would be absorbed with earth, sand or other non-combustible

material and transferred to containers for later disposal using clean, non-sparking tools to collect absorbed material. Large spills would be contained through the use of secondary containment systems. In the event of the release of reportable quantities of a hazardous substance, the emergency response plan would be initiated and the appropriate authorities would be notified. Protective equipment, including personal protective equipment (PPE) for eyes, face, head, and extremities, protective clothing, respiratory devices and protective shield and barriers would be available at designated locations throughout the facility and personnel would be trained in its proper use. Leucadia would provide PPE wherever process or environmental hazards, chemical hazards, radiological hazards, or mechanical irritants could be encountered in a manner capable of causing injury or impairment in the function of any part of the body thorough absorption, inhalation, or physical contact.

In addition, operators would be present at the facility twenty-four hours per day, seven days per week. Leucadia's storage tank practices and Preventive Maintenance and Inspection Program would include the following:

1. The main outlet valve on each tank would be manually secured in the closed position when the tank is unattended.
2. Venting capacity would be suitable for fill and withdrawal rates to prevent over pressurization.
3. Personnel would immediately place a drip pan in position under any flange, valve, gauge or fitting to recover any spill when noticed. Further, the spill would immediately be reported per the internal notification procedure for corrective action.
4. The outside of each tank would be observed during process checks (approximately every 2 hours) by operating personnel for signs of deterioration, leaks or accumulation of raw material inside the containment area.
5. Physical spot checks would be conducted on a daily basis of all above ground tanks, valves, pipelines, joints, connections and supports.
6. All storage tanks would be visually examined on a daily basis for leaks from seams, gaskets, rivets, and bolts. Operation personnel would perform this activity during their routine checks of the associated operating equipment. In the event of a defect, the supervisor would be immediately notified.
7. Twenty-four hour per day security would be provided, including adequate lights and fencing.

Methanol and sulfuric acid would be transported to and from the off-site storage area via pipeline. Leucadia would develop an emergency response plan to ensure pipeline integrity and safety during normal operations and a leak and spill prevention plan to prevent and respond to leaks or spills that could occur from the pipelines. Leucadia's leak and spill prevention and containment and control measures include: continuous pressure monitoring of vessels and pipes, automatic shut-off devices and relief valves, curbing or diking to contain liquid releases, redundant equipment and instrumentation (uninterruptible power supply for process control system, backup firewater pumps), audible warning alarms and administrative controls to

minimize hazardous materials inventories. In the event of an accidental spill or leak, Leucadia would implement the facility emergency response plan, notify the appropriate authorities, and utilize trained emergency response personnel with the appropriate personal protective equipment (chemical protective clothing, self-contained breathing apparatus) to identify and shut down the source and contain spills.

Periodic maintenance and inspection activities during operation of the pipeline corridors would require that any necessary materials required for servicing and monitoring of pipeline systems and components be transported into the pipeline corridor ROW in service vehicles and used at the work location as needed. Materials would not be stored within the pipeline corridor ROW. Maintenance activities would typically require mowing, vegetation clearing, maintaining access and service roads, and servicing and monitoring of pipeline system components. If oil, gas, or other fluids spilled along the ROW, Leucadia or its contractors would immediately initiate response actions, provide notice to regulatory agencies as necessary, and initiate cleanup action. Routine maintenance and monitoring activities are not expected to produce any demands on the regional supply of materials or generate appreciable quantities of waste, and impact would be considered negligible.

Materials and supplies required for operation of the LCCE Gasification plant are regionally available and new sources of materials and supplies would not be created; therefore operation of the plant would have no impact on the availability of materials in the region. A minor increase in the amount of fuel, oil, and solvents is expected to support the new equipment and operations.

Leucadia would incorporate the safe handling and storage of these materials into a hazardous materials management plan to minimize the potential for a release. It is not expected that spills or leaks that could occur during normal operations would result in the release of hazardous materials outside of the secondary containment area. As a result, operation of the LCCE Gasification plant would include measures to decrease the potential for release of a hazardous material to the environment. The impact from the storage and use of these materials would be considered minor.

4.13.3 Lake Charles CCS Project

4.13.3.1 CO₂ Capture and Compression Facilities

Construction

Construction of the CO₂ capture facility and compression facilities would occur within the LCCE Gasification plant site. Construction impacts associated with the CO₂ capture and compression facilities are included with those for the LCCE Gasification plant described above in section 4.13.2.1.1.

Operation

Section 2.5.2.2 describes the typical materials used or generated during operation of the CO₂ capture and compression facilities. Table 4.13-3 summarizes the hazardous materials that would be used during operation in significant quantities or of significant hazardous characteristics; the quantity to be used, stored or generated; whether the material exceeds the threshold quantity for evaluation of risks of releases; its physical phase, and the type of secondary containment proposed.

Operation of the CO₂ capture and compression facilities would occur as an integrated component of the LCCE Gasification plant. Regulatory requirements that address the manufacture, processing, distribution, use, and disposal of commercial and industrial chemicals during operation of the LCCE Gasification plant, which are described above in Section 4.13.2.2, would be the same for the CO₂ capture and compression facilities.

Table 4.13-3 Hazardous Materials Used During Operation of the Lake Charles CO₂ Capture and Compression Facilities.

Chemical Name	CAS No.	Annual Quantity	Risk Management Program Threshold Quantity	Physical State	Secondary Containment
Methanol	67-56-1	250,000 lbs.	Not Applicable	Liquid	Containment curbs in the process area
Propylene [1-Propene]	115-07-1	11,400 lbs.	10,000 lbs	Compressed Liquid / Gas	Closed system

4.13.3.2 Lake Charles CCS CO₂ Pipeline

4.13.3.2.1 Proposed Route

Construction

Construction of the pipeline would require carbon steel pipe, valves, pumps, fittings, process materials, and cathodic protection equipment, controls, and monitoring systems. Construction equipment would typically include excavators, as well as smaller equipment such as backhoes, dump trucks, compactors, compressors, and welding equipment. Denbury would select a pipeline contractor who to the extent practical, would purchase the necessary equipment to complete construction, testing, and commissioning from local and regional domestic suppliers that would meet design specifications and applicable regulations and codes.

The pipeline contractor would be responsible for furnishing and maintaining construction and test equipment necessary to complete pipeline construction, perform hydrostatic testing, and enable pipeline commissioning. During the construction period, there may be demand for pipeline materials and equipment in the region. This demand would be temporary and would not impact other projects in the region.

Construction materials (e.g., fuel, lubricants, transmission fluids, oils) necessary for the operation and maintenance of equipment and vehicles would be stored at off-site work areas. Some of these materials are considered hazardous substances. Small amounts of materials and oil products may spill as a result of equipment failure (split hydraulic lines, broken fittings) or human error (overfilled tanks).

OSHA Construction Industry Standards defined in 29 CFR 1926 would also be applicable to construction activities for the CO₂ pipeline. Denbury would require pipeline construction contractors to provide an implementation plan and a schedule for construction materials acquisition and materials storage. The contractor plan would provide for adequate storage of materials (e.g., fuel, lubricants, transmission fluids, oils) necessary for the operation and maintenance of equipment and vehicles at the work sites. Hazardous materials would be stored in

secondary containment and would be stored in a manner to minimize the potential for storm water contact.

Denbury's safety program is designed to minimize incidents and lost time injuries, and to protect the public near the pipeline. Denbury would conduct group safety training sessions for inspection crews and construction contractor personnel prior to construction and each morning before construction activities begin. The construction contractor would also be required to have a safety representative onsite during construction. Denbury requires that construction contractors perform all construction activities in a safe manner, including the operation of all construction equipment, all labor activities, and complying with OSHA's excavation safety standards.

During construction, Denbury would send letters to the owners of all known, reported, or otherwise documented pipelines within the proposed work areas along with drawings showing the location of the owners' respective lines. In the letters, Denbury would request a written response to the following inquiries:

- Size, type, and pressure
- Verification of the location and depth of cover
- ROW width
- Information concerning other pipelines immediately adjacent to or intersecting the new pipeline that were identified
- Special construction requirements
- Names, addresses, telephone numbers, and lead time of personnel to contact before construction begins

During construction, the contractor would complete the One Call notification to allow operators of foreign pipelines and utilities to probe and mark each line. Each foreign utility line would be carefully exposed before trenching.

The materials and equipment necessary to construct the pipeline are expected to be readily available and within the capacity of suppliers in the region; however, construction of the proposed pipeline could increase demand for pipe and associated materials within the region. This demand would be temporary and would not impact other projects in the region. As a result, impacts on local and regional supplies would be negligible.

Denbury would store and manage potentially hazardous materials in accordance with all applicable manufacturer and regulatory requirements and BMPs, including appropriate containment, curbing, routine spill inspections, and, where applicable, compliance with the SPCC, SWPPP, and SPC requirements. As a result, construction would include measures to decrease the potential for release of a hazardous material to the environment. Impacts of small spills during construction would be temporary and minor.

Operation

The CO₂ pipeline would transport supercritical CO₂ at a pressure of 2,250 psig to the existing Green Pipeline. Supercritical CO₂ is a gas with flow properties like a liquid. During operation of the pipeline, Denbury would perform routine maintenance and monitoring of the pipeline and associated components. Materials required for servicing and monitoring of pipeline systems and components would be transported into the pipeline ROW in vehicles and used at the work location as needed.

DOT's Pipeline and Hazardous Materials Safety Administration (PHMSA) regulates the transport of hazardous materials. Within PHMSA, the Office of Pipeline Safety (OPS) is responsible for administering Pipeline Safety regulatory programs for hazardous liquid pipelines. DOT has established minimum federal safety standards in 49 CFR Part 195, "Transportation of Hazardous Liquids by Pipeline" that are intended to ensure adequate protection for the public from hazardous liquid and carbon dioxide pipeline failures. Part 195 specifies material selection and qualification, minimum design requirements, and protection from internal, external, and atmospheric corrosion. Some key provisions of the Part 195 regulations are summarized below:

- System materials and design (49 CFR 195 Subpart C – Design Requirements)
- Proper construction (49 CFR 195 Subpart D – Construction, and Subpart E – Pressure Testing)
- Thorough and adequate inspection, testing, maintenance and repair (49 CFR 195 Subpart F – Operation and Maintenance, 195.402 – Procedural manual for operations, maintenance, and emergencies, and 195.442 – Damage Prevention Program)
- Operations conducted by trained and qualified workers (49 CFR 195 Subpart G – Qualification of Pipeline Personnel)
- Identification and mitigation of risks (195.452 - Pipeline Integrity Management)
- Coordination and preparation for emergency response (195.402 – Procedural manual for operations, maintenance, and emergencies, 195.403 – Emergency Response Training)

In addition to the provisions outlined above, many industry standards are incorporated by reference into 49 CFR Part 195, and are therefore regulatory requirements. These standards provide specifications for materials, fabrication, construction, pipe transportation, and corroded pipe analysis, which contribute to the safety of the pipeline system, and would be used in the design, operation, and maintenance of the proposed pipeline. For example, the proposed pipeline would be constructed of carbon steel manufactured in accordance with American Petroleum Institute (API) 5L, Grade X70, PSL 2 specifications, with an electric resistance welded (ERW) longitudinal weld seam. All pipe and appurtenances installed below grade would be coated with fusion-bonded epoxy or an equivalent protective coating, and painted with an industrial epoxy paint system for above grade installation. Buried pipeline joints would be coated with field-applied epoxy coatings. An impressed current cathodic protection system would be installed to further protect the integrity of the pipeline.

The requirements of 49 CFR 195.452 include provisions for an Integrity Management Plan and establishes a methodology for identifying a High Consequence Area (HCA), risk assessment of individual line segments, integrity assessment intervals, approved methods of assessment, criteria for prioritizing and repairing anomalies found during assessments, and documentation of all activities related to integrity management. HCAs are populated and sensitive areas published by PHMSA and used during the risk assessment process required of each natural gas and hazardous liquid pipeline operator.

An operations control center would monitor system pressures, flows, and deliveries 24 hours per day, 365 days per year. The operator would have remote operational control of specific mainline valves. A Supervisory Control and Data Acquisition (SCADA) system, in the operations control center, would provide for pipeline control and monitoring at all times. Remote Terminal Units (RTU's) for the SCADA system would be present at the end point stations and specific block valves along the system. If system pressures fall outside a predetermined range, an alarm would be activated and notice would be transmitted to the operations control center. The alarm would include notice if pressures at a station are not within an acceptable range. The operator would take corrective action and/or dispatch personnel to investigate the situation. Denbury personnel would provide quick response to emergencies and direct safety operations as necessary.

Denbury maintains an operations and maintenance manual containing written procedures for normal operations and maintenance and abnormal operations and emergencies in accordance with DOT 49 CFR 195 regulations for its existing CO₂ pipelines. This manual includes requirements for preventive maintenance and patrols of facilities, as well as procedures to be followed in the event of an accident or natural catastrophe. Periodic training sessions and review of operating procedures and emergency procedures include the safe operation of all pipeline system equipment, hazardous material handling procedures, public liaison programs, emergency response actions and coordination, and general operating procedures.

Measures to protect the public and exclude unauthorized persons from hazardous areas along the pipeline are also part of Denbury's operations and maintenance plans. All above ground facilities would have perimeter chain link fencing with multiple-strand barbed wire at the top. Valves and access gates would be locked at unmanned locations. Signage at facilities would include statements such as "Authorized Personnel Only." On the ROW, pipeline warning signs complying with DOT regulations would be placed at all road, railroad and waterway crossings and at other locations of public access. Additionally, aerial patrols would give immediate phone notification to dispatch operations personnel of any apparent activity by the public near the pipeline that could be an endangerment to people and the pipeline.

Standard procedures would be implemented for temporary marking of the pipeline for third party contractors and utilities, and for obtaining adequate marking and location information of foreign lines and utilities prior to commencing maintenance work. Standard procedures would be implemented for maintenance activities such as lock-out / tag-out procedures, checking for low-oxygen atmospheres when the pipeline is opened, procedures for excavating pipelines and utilities, traffic control, and procedures that would ensure compliance with pertinent OSHA regulations. Regularly scheduled aerial patrols of all Lake Charles lateral facilities would be performed along with scheduled preventive maintenance. Periodic vehicle patrols would also be used. Any unusual situation or condition would be reported and investigated immediately.

Denbury is also a member of the local Louisiana “One Call” System pre-excavation notification organization. Through this system, contractors provide notification to a central agency of proposed excavations, which in turn notifies the operator of the excavation locations. If facilities are located in the area of proposed contractor activity, they would be marked in the field, and a representative of the operator would be present during excavation to ensure that the facility is not compromised.

During normal operation, routine maintenance and monitoring activities would occur along the proposed CO₂ pipeline. These activities would use materials that are readily available and impacts to the regional supply of materials would be negligible. No materials would be stored along the pipeline ROW, therefore the risk of a release of hazardous materials during operation would be negligible. The potential for an accidental release of CO₂ from the pipeline is evaluated in Section 4.15.

4.13.3.2.2 Alternative Route B

The materials that would be used for the alternative pipeline route would be the same as described in Section 4.13.4.1 for construction and operation of the proposed pipeline route.

4.13.3.3 West Hastings Research MVA

Materials used to conduct existing routine oil field operations, well conversions, and maintenance include fuels, oils, lubricants, corrosion inhibitors, ready-mix concrete, gravel fill, reinforcing steel, equipment rentals, piping, fittings, valves, and welding materials. Denbury has established programs and processes in place to purchase material, equipment, supplies, and contractor services as part of its ongoing commercial EOR operation that would also be used for the research MVA activities.

Denbury would implement its hazardous materials management plan, safety program, risk minimization measures, BMP's, and its SWPPP and SPCC plans, where applicable, to minimize the risk of a hazardous material release.

Operation of the research MVA site would have negligible impacts on the regional availability of materials and would not cause new sources of materials to be created. Supplies and materials required for operation are readily available from numerous in-state suppliers and from out-of-state suppliers as necessary. During normal operations, the risk of a release of hazardous materials would be negligible.

4.13.4 Summary of Impacts

Tables 4.13-4 and 4.13-5 present summaries of the materials impacts and minimization measures for the LCCE Gasification plant and the Lake Charles CCS project.

Table 4.13-4 Summary of Potential Impacts on Materials and Minimization Measures for LCCE Gasification Plant and Off-site Activities

Impact	Minimization Measure(s)
<p>Construction: Minor Construction materials would consist of concrete, wood, fuel, and steel. Construction materials and specialized construction equipment are readily available from in-state and regional vendors and fabricators. Locally obtained materials would include crushed stone, sand, and lumber for the proposed facilities and temporary structures (e.g., enclosures, forms, and scaffolding). Construction would require small volumes of commercially available chemicals, including paints and cleaners, and materials for operating and maintaining vehicles and equipment (lubricants, transmission fluids, oils).</p>	<p>Leucadia would store and manage potentially hazardous materials in accordance with all applicable manufacturer and regulatory requirements, BMPs, and their SPCC, SWPP, and SPC plans.</p>
<p>Operation: Negligible Petcoke, fluxant, fuel, aqueous ammonia, and chlorine would be the primary materials used. Operation would use or produce industrial chemicals, including aqueous ammonia, methanol, sulfuric acid, hydrogen, and fuels.</p>	<p>In accordance with regulatory requirements, Leucadia would develop and implement a Hazardous Materials Handling, Usage and Storage Plan, OSHA Process Safety Management Program, Risk Management Plan, Emergency Response Plan, and Fire Prevention and Protection Program, and would conduct safety and compliance audits.</p>

Table 4.13-5 Summary of Potential Impacts on Materials and Minimization Measures for Lake Charles CCS Project

Impact	Minimization Measure(s)
<p>Construction of the CO₂ Capture and Compression Facilities: Minor Included in the LCCE Gasification plant (see Table 4.13-4)</p>	<p>Included in the LCCE Gasification plant (see Table 4.13-4)</p>
<p>Operation of the CO₂ Capture and Compression Facilities: Negligible Methanol and propylene would be the primary materials used. CO₂ would be produced. Operation would occur as an integrated component of the LCCE Gasification plant.</p>	<p>Included in the LCCE Gasification plant (see Table 4.13-4)</p>
<p>Construction of the CO₂ Pipeline or Alternative Pipeline: Minor Construction would require materials such as carbon steel pipe, valves, pumps, fittings, process materials, cathodic protection equipment, controls and monitoring systems. Also, fuel, lubricants, transmission fluids, and oils would be required for the operation and maintenance of equipment and vehicles.</p>	<p>Denbury would store and manage potentially hazardous materials in accordance with all applicable manufacturer and regulatory requirements, BMPs, and their SPCC, SWPP, and SPC plans.</p>

Table 4.13-5 Summary of Potential Impacts on Materials and Minimization Measures for Lake Charles CCS Project

Impact	Minimization Measure(s)
<p>Operation of the CO₂ Pipeline or Alternative Pipeline: Negligible Supercritical CO₂, which flows like a liquid, would be transported via the pipeline. Fuel, lubricants, transmission fluids, and oils would be required for the operation and maintenance of equipment and vehicles used for routine maintenance and monitoring of the pipeline and pipeline system components.</p>	<p>In accordance with the DOT federal safety regulations for transportation of hazardous liquids by pipeline, Denbury would add the CO₂ pipeline to its existing Integrity Management Plan, and maintain an operations and maintenance manual containing procedures for normal operations, maintenance, abnormal operations, and emergencies.</p> <p>Denbury would store and manage potentially hazardous materials in accordance with all applicable manufacturer and regulatory requirements, BMPs, and their SPCC, SWPP, and SPC plans.</p>
<p>Operation of the West Hastings research MVA program: Negligible Materials used include fuels, oils, lubricants, corrosion inhibitors, ready-mix concrete, gravel fill, reinforcing steel, equipment rentals, piping, fittings, valves, and welding materials.</p>	<p>Leucadia would store and manage potentially hazardous materials in accordance with all applicable manufacturer and regulatory requirements, BMPs, and their SPCC, SWPP, and SPC plans.</p>

4.14 Human Health and Safety

4.14.1 Factors Considered for Assessing Impacts

DOE assessed potential impacts on human health based on whether the proposed project or connected action could directly or indirectly result in an increase of:

- Worker health risks during construction or operation, or
- Public health impacts from exposure to emissions or hazardous materials during construction or normal operation.

This assessment considered health effects criteria, federal and state regulations, project design and operating procedures, and industry data from similar facilities to evaluate worker and public health risks during construction and operation. Section 4.15 presents the analysis of potential for human health risks associated with accidental releases.

The potential impacts on human health from construction and operation of the LCCE Gasification plant and Lake Charles CCS project would be common to many petrochemical process systems and oil and gas developments in the U.S. and worldwide. Potential hazards would be a function of the materials being handled, handling systems, procedures used for operating and maintaining the systems, and hazard detection and mitigation systems provided.

Potential occupational safety impacts were estimated based on the national workplace injury, illness, and fatality rates (USBLS 2013) provided in Tables 3.13-1. An OSHA recordable case is defined as a work-related accident that results in lost time, work restriction, medical treatment, or death. Based on these data, the projected numbers of total recordable cases, cases of lost work days, and fatalities were calculated.

This evaluation of potential impacts on public health during construction and normal operation considered air emissions and the use, storage, and generation of hazardous materials. Based on the physical and chemical properties of the materials, DOE identified applicable regulatory requirements and design and operating practices to minimize public health risks during normal operation.

4.14.2 LCCE Gasification Plant

4.14.2.1 Construction

In general, the impacts during construction would be limited to workers directly involved in the various aspects of construction. Construction of the LCCE Gasification plant and the Lake Charles CO₂ Capture and Compression facilities would occur simultaneously and would be accomplished using typical methods for industrial construction site areas. Construction would involve several types of heavy equipment and experienced personnel necessary to erect the structures for the facilities. The occupational exposure risks would be typical for an industrial construction project.

Construction equipment would likely include cranes, powered industrial lifts, compressors, welding equipment, scaffolds, trucks, and trailers. Construction materials would consist of structural steel, concrete, piping, and earthen materials. Components would include ductwork, wiring, cables, insulation, fans, motors, compressors, and other equipment necessary to construct the facility. Construction would require laydown areas that would be within the property line of the site and at the offsite laydown area. Because of the conventional nature of the activities, it is not expected that construction workers would be exposed to significant airborne hazards.

Construction is expected to be similar to heavy construction and would use comparable materials, equipment, and procedures to minimize potential worker exposures. Construction activities would involve the cooperation of multiple work crews and associated support equipment and vehicles. Noise levels during some of the construction activities would likely exceed occupational standards for site workers and would require hearing protection.

Construction is expected to take approximately 36 months to complete, and the number of construction personnel would vary depending on the construction activity being performed. An estimated 84 OSHA-recordable cases and 46 cases with days away would be anticipated during construction, based on national incidence rates for non-residential construction and the estimated 900 construction workers employed on site during the peak construction period. Based on fatality rates for construction and extraction and the number of construction personnel, the fatality rate would be below one (0.31) and no fatalities would be expected.

OSHA Construction Industry Standards are defined in 29 CFR Part 1926 and include requirements for policies, procedures, and practices to ensure protection of the workforce, environment, and public. Before construction activities begin, Leucadia would prepare a worker protection program and would require all contractors to develop, implement, and maintain a Worker Protection Plan. This safety and accident prevention program would provide specifically defined goals and objectives for the safety, health, and welfare of all employees and protection of the public during construction activities. The program would comply with and complement federal, state, and local regulations. Leucadia's program contains three primary elements:

Management, Leadership, and Employee Involvement; Worksite Analysis and Hazard Prevention and Control; and Safety and Health Training and Education.

As discussed in Section 4.2.2, the mobile sources used during construction would not produce emissions that would expose sensitive receptors to substantial pollutant concentrations. Leucadia would implement specific site access procedures during construction to prevent unauthorized entry to the construction area, including perimeter fencing and gated access for the site and the off-site laydown area. Potential health effects on the general public would not be expected during construction activities, as it is not expected that the public would be at the plant site or off-site laydown area, nor would the general public be exposed to chemical or industrial hazards or contaminants that would exceed public health standards.

4.14.2.2 Operation

In general, the impacts during normal operations of the project would be limited to workers directly involved in facility operation and maintenance. Workers would be exposed to hazards typical of an industrial setting, which include physical hazards (slipping, tripping, and fall hazards) and potential exposure to chemicals or other industrial hazards. The USBLs data on gasification facilities are not available. Incident rates from the petroleum refineries sector were used in this analysis. An estimated 62 OSHA-recordable cases and 34 cases with days away would be anticipated during operation based on national incidence rates and the estimated 187 workers employed during the 30 year life of the plant. Based on fatality rates for petroleum refineries, the fatality rate would be below one (0.02) and no fatalities would be expected.

OSHA's Process Safety Management Standards defined in 29 CFR Part 1910.119 are designed to protect workers from potential industrial accidents and minimize exposure to workplace hazards (e.g., noise, chemicals). PSM is the proactive identification, evaluation, and mitigation or prevention of chemical releases that could occur as a result of failures in processes, procedures, or equipment (OSHA 1994). The PSM standard applies to processes that use or store hazardous or flammable substances above the threshold quantities. A process safety management program requires a systematic approach to the process design, process technology, process changes, operational and maintenance activities and procedures, non-routine activities and procedures, emergency preparedness plans and procedures, and training programs.

Section 4.13 summarizes the hazardous materials that would be used or generated in significant quantities during operation of the LCCE Gasification plant (see Table 4.13-1) and the Lake Charles CCS project (see Table 4.13-2). Leucadia would prepare written safety and accident prevention programs for the purpose of providing specifically defined goals and objectives to be attained for the safety, health, and welfare of all employees and protection of the public during operation activities. Leucadia would comply with applicable guidance from OSHA and other applicable industry standards and regulations in the design, construction, and operation of the facility to prevent impacts on worker health.

Table 4.2-8 summarizes the impacts of air emissions for criteria pollutants and toxic air pollutants. None of the maximum ground-level concentrations would cause or contribute to any violation of the NAAQS or Louisiana ambient air standards or expose sensitive receptors to substantial pollutant concentrations.

As described in 4.13.2.2, facilities that produce, handle, process, distribute, or store certain chemicals must develop a Risk Management Program, prepare a Risk Management Plan and submit the RMP to the EPA. If an accidental chemical release could affect the public, the facility must analyze more realistic scenarios and develop and implement a prevention program that includes identification of hazards, written operating procedures, training, maintenance, and accident investigation procedures. Leucadia would implement the appropriate requirements of the PSM and RMP before any of the chemicals are brought on site for operation.

Potential health effects on the general public would be negligible during normal operations, as it is expected that the public would not be on site or be exposed to chemical or industrial hazards or contaminants that would exceed public health standards.

4.14.3 Lake Charles CCS Project

4.14.3.1 CO₂ Capture and Compression Facilities

Construction and operation of the LCCE Gasification plant includes construction and operation of the CO₂ capture and compression facilities. Impacts on worker safety and public health from construction and operation of the CO₂ capture and compression facilities are included in the impacts on worker safety and public health described for the LCCE Gasification plant.

4.14.3.2 CO₂ Pipeline

4.14.3.2.1 Proposed Route

Construction of the CO₂ pipeline is expected to be similar to typical pipeline construction and would use comparable materials, equipment and procedures to minimize potential worker exposures. Excavations would be constructed with proper shoring or benching to minimize the risk of cave-ins, and excavated soil would be stockpiled to minimize slumping into the excavation. If applicable, two means of egress would be provided for each excavation.

Installation of the pipeline is expected to take approximately 3 to 4 months to complete and the number of construction personnel would vary depending on the construction activity being performed. An estimated one OSHA-recordable cases of 1.08 and 0.6 cases with days away would be anticipated during the construction of the CO₂ pipeline, based on national incidence rates and 250 employees during the peak construction period. Based on fatality rates for the oil and gas pipeline and related structures construction sector, the fatality rate would be below one (0.01) and no fatalities would be expected.

Denbury would develop and maintain a safety program designed to minimize incidents and lost time injuries. Denbury would require that all construction contractors perform construction activities in a safe manner--including the operation of all construction equipment and all labor activities-- and comply with OSHA's excavation safety standards. Excavations would be constructed with proper shoring or benching to minimize the risk of cave-ins and excavated soil would be stockpiled to minimize slumping into the excavation.

As described in 4.13.4.1.2, safety regulations applicable to CO₂ pipelines are found at 49 CFR Part 195. Denbury would implement specific ROW access procedures that would prevent public access to the ROW during construction activities. Potential health effects on the general public would not be expected during pipeline construction activities, as the public would not be entering the construction areas or be exposed to chemical or industrial hazards or contaminants that would exceed public health standards.

Operation

Operation and maintenance of the pipeline would include routine and periodic inspections and testing of equipment. The staff would include a supervisor and two technicians who would operate the pipeline and pump stations and complete inspections of the pipeline ROW. The technicians would calibrate and maintain the meter equipment, meters, motor-operated valves, and pump station instrumentation from the Calcasieu River west to the West Hastings oil field. Denbury would man an operations control center 24 hours per day, 365 days per year. The operations control center would monitor system pressures, flows, and customer deliveries, and would include remote operation and control of specific mainline valves along the ROW. A Supervisory Control and Data Acquisition (SCADA) system in the operations control center would provide for pipeline control and monitoring at all times. For example, if pipeline pressures fall outside a predetermined range, an alarm would be activated and notice would be transmitted to the operations control center so that the operator could take corrective actions and/or dispatch personnel to investigate.

Potential occupational safety impacts associated with operation of the pipeline project were estimated based on national workplace injury, illness, and fatality rates for the pipeline transportation sector. An estimated 1.5 OSHA-recordable cases and 1.2 cases with days away would be anticipated during a 30-year life of the pipeline, based on national incidence rates and the estimated three workers employed during operation of the pipeline.

As described in 4.13.4.1.2, safety regulations applicable to CO₂ pipelines are found at 49 CFR Part 195. In accordance with the federal requirement under 49 CFR 195.452 (Pipeline Integrity Management Plan in High Consequence Areas), Denbury would add the proposed CO₂ pipeline to its existing Integrity Management Plan (IMP) and program. Denbury would maintain an operations and maintenance manual containing written procedures for normal operations, maintenance, abnormal operations, and emergencies. Denbury's procedures for compliance with the IMP requirements are described in 4.13.4.1.2.

Denbury would also implement measures to protect the public and exclude unauthorized persons from potentially hazardous areas along the pipeline. All aboveground facilities would have perimeter chain link fencing with multiple-strand barbed wire at the top. Valves and access gates would be locked at unmanned locations. Signage at facilities would include statements such as "Authorized Personnel Only." On the ROW, pipeline warning signs complying with DOT regulations would be placed at all road, railroad, and waterway crossings and at other locations of potential public access. The signs would direct the public to call the operations control center and the local one-call notification center at least 48 hours before commencing any excavation near the pipeline. Additionally, aerial patrols would notify operations personnel of any apparent activity near the pipeline that could endanger people and the pipeline.

Denbury is a member of the local Louisiana "One Call" system pre-excavation notification organization. Through this system, local contractors provide notification to a central agency of proposed excavations. If the pipeline is located in the area of proposed contractor activity, the pipeline ROW would be marked in the field and a Denbury representative would be present during excavation to ensure that the pipeline is not compromised.

Potential health effects on the general public would be negligible during normal pipeline operations, as it is expected that the public would not be exposed to CO₂ or other industrial hazards or contaminants that would exceed public health standards. Potential health impacts from an accidental release are analyzed in Section 4.15.

4.14.3.2.2 Alternative Route B

The potential impacts on public health from operation of the alternative pipeline route would be similar to those described above for the preferred pipeline route. Construction and operation of the alternative pipeline route would not generate different types of impacts on public health.

4.14.3.3 West Hastings Research MVA Program

As described in Section 2.4.3, the research MVA program would include field work related to reworking of wells, including use of a workover rig and temporary support equipment placed at the existing well pads. These activities would be similar to the current EOR commercial operations performed at the West Hastings oil field. The research MVA activities would include implementation of techniques to model, observe, and monitor the movement of CO₂ in subsurface formations. Denbury and BEG field personnel would perform annual vertical seismic profiling (VSP) surveys of the project site; surface and borehole gravity monitoring; real-time bottom hole pressure measurements; and sampling and analysis to determine geochemical parameters above the injection zone. Based on these field activities, Denbury and BEG would perform computer-based modeling to confirm CO₂ migration distance in the reservoir.

Denbury's and BEG's staff have experience with the research MVA activities because of the similarity to the current commercial MVA for the ongoing EOR operation at the West Hastings oil field. Workers are trained on safety procedures, especially those related to the handling of high-pressure CO₂. Additionally, Denbury would comply with the applicable requirements of OSHA. Potential health impacts on workers implementing the West Hastings research MVA activities would be typical of those for the ongoing commercial EOR operation and commercial MVA program. Potential health impacts on workers during the West Hastings research MVA activities would be negligible.

The West Hastings oil field is located in a sparsely populated area with an active commercial EOR operation. Noise from diesel engines would be audible in the immediate vicinity of an active well during conversion/reworking operations and would alert workers to the use of heavy equipment (Walden 2010). Access to roads and well pads are monitored during the day by Denbury personnel and a security patrol at night. The wellheads are protected from unauthorized public access by a chain link fence and locked. Potential health impacts on the general public would be negligible during the West Hastings research MVA activities, as it is expected that the public would not enter the areas or be exposed to chemical or industrial hazards or contaminants that would exceed public health standards.

4.14.4 Summary of Impacts

Tables 4.14-1 and 4.14-2 present summaries of the human health impacts and minimization measures for the LCCE Gasification plant and the Lake Charles CCS project.

Table 4.14-1 Summary of Potential Impacts on Human Health and Safety and Minimization Measures for LCCE Gasification Plant and Off-site Activities

Potential Impacts	Minimization Measure(s)
<p>Construction: Negligible An estimated 84 OSHA recordable cases and 46 cases with days away would be anticipated during construction based on national incidence rates and the estimated 900 construction workers employed on site during peak construction. The public would not have access to the construction area. Vehicle emissions would not expose sensitive receptors to substantial pollutant concentrations.</p>	<p>Prior to construction, Leucadia would prepare a worker protection program that addresses worker safety and accident prevention. Leucadia would require that all contractors develop, implement, and maintain a worker protection plan in accordance with OSHA Construction Industry Standards, and other federal, state, and local regulations.</p>
<p>Operation: Negligible An estimated 62 OSHA-recordable cases and 34 cases with days away would be anticipated during operation based on national incidence rates and the estimated 187 workers employed during the 30-year life of the plant. Based on fatality rates for petroleum refineries, the fatality rate would be below one (0.02) and no fatalities would be expected. Air emissions of criteria pollutants and toxic air pollutants do not cause or contribute to any violation of the ambient air quality standards or expose sensitive receptors to substantial pollutant concentrations.</p>	<p>In accordance with regulatory requirements, Leucadia would develop and implement a Hazardous Materials Handling, Usage and Storage Plan, OSHA Process Safety Management Program, Risk Management Plan, Emergency Response Plan, and Fire Prevention and Protection Program, and would conduct safety and compliance audits.</p>

Table 4.14-2 Summary of Potential Impacts on Human Health and Safety and Minimization Measures for Lake Charles CCS Project

Potential Impacts	Minimization Measure(s)
<p>Construction and Operation of the CO₂ Capture and Compression Facilities: Minor Included in the LCCE Gasification plant (see Table 4.14-1)</p>	<p>Included in the LCCE Gasification plant (see Table 4.14-1)</p>
<p>Construction of the CO₂ Pipeline or Alternative Pipeline: Negligible An estimated 1.08 OSHA-recordable cases and 0.6 cases with days away would be anticipated during the construction of the CO₂ pipeline based on national incidence rates and 250 employees during the peak construction period. Based on fatality rates for construction and extraction sector, the fatality rate would be below 1 at 0.01 and no fatalities would be expected. It is not expected that the public would be on site or be exposed to chemical or industrial hazards or contaminants that would exceed public health standards.</p>	<p>Prior to construction, Denbury would prepare a worker protection program that addresses worker safety and accident prevention. Denbury would require that all contractors develop, implement, and maintain a worker protection plan in accordance with OSHA Construction Industry Standards and other federal, state, and local regulations.</p>

Table 4.14-2 Summary of Potential Impacts on Human Health and Safety and Minimization Measures for Lake Charles CCS Project

Potential Impacts	Minimization Measure(s)
<p>Operation of the CO₂ Pipeline or Alternative Pipeline: Negligible Supercritical CO₂ would be transported via the pipeline.</p> <p>An estimated 1.35 OSHA-recordable cases and 1.08 cases with days away would be anticipated during a 30-year life of the pipeline, based on national incidence rates and the estimated number of workers employed during operation of the pipeline.</p>	<p>In accordance with the DOT federal safety regulations for transportation of hazardous liquids by pipeline, Denbury would add the CO₂ pipeline to its existing Integrity Management Plan, and maintain an operations and maintenance manual containing procedures for normal operations, maintenance, abnormal operations, and emergencies.</p>
<p>Operation of the West Hastings research MVA program: Negligible Potential health impacts on workers would be typical of those for the ongoing commercial EOR operation and commercial MVA program.</p>	<p>Denbury would comply with all applicable requirements of OSHA.</p>

4.15 Accident Analyses

4.15.1 Factors Considered for Assessing Impacts

DOE assessed potential impacts on worker safety, public health, and the environment based on whether the proposed project or connected action could directly or indirectly result in an increase of:

- Human health and ecological risks from accidental releases of hazardous materials;
- Human health and ecological risks from accidental releases of CO₂ at the capture facility and pipeline, or from the geologic storage activities; or
- Human health risks from intentional destructive acts.

Under non-routine operating conditions, accidental releases of hazardous chemicals used, generated, stored, or transported may occur and the health and safety of workers and members of the general public around the site could be affected. DOE considered a range of accident scenarios that could result in the release of hazardous chemicals and gases, or the chemicals of concern associated with the LCCE Gasification plant or the Lake Charles CCS Project. This section discusses the potential consequences of the release on the environment and human health.

Section 4.13 identified the hazardous materials that would be used or generated during operation of the LCCE Gasification plant and the Lake Charles CCS project. Table 4.15-1 below provides a summary of these chemicals, the process or operational areas where these would be either handled or produced, and their physical state.

Table 4.15-1 Chemicals of Potential Concern

Chemical Name	LCCE Gasification Plant	Lake Charles CCS Project		Physical State
	Location, Purpose, or Use			
Aqueous Ammonia (Ammonium Hydroxide) (19% NH ₃)	SCR process and storage	N/A	N/A	Liquid
Chlorine	Cooling Towers and Storage	NA	N/A	Compressed Gas
Carbon Dioxide	Gasifier	CO ₂ Capture and Compression	Pipeline Transport	Gas
Carbon Monoxide	Gasifier	CO ₂ Capture	N/A	Gas
Hydrogen sulfide	Gasifier and WSA	CO ₂ Capture	N/A	Gas
Methanol	Production, Storage, and Transport	CO ₂ Capture	N/A	Liquid
Hydrogen	Production and Transport	CO ₂ Capture	N/A	Gas
Sulfuric Acid	Production, Storage, and Transport	N/A	N/A	Liquid
Propylene	N/A	CO ₂ Compression	N/A	Gas and Liquid

Acute Exposure Guideline Levels (AEGL) comprise a number of exposure concentration and duration pairs (ranging from 10 minutes to 8 hours) expected to result in three levels of health effect outcomes of increasing severity. The National Advisory Committee for the Development of Acute Exposure Guideline Levels developed these levels for hazardous substances (AEGL Committee). The three AEGL levels are defined as:

- AEGL 1: The airborne concentration of a substance above which it is predicted that the general population, including susceptible individuals, could experience notable discomfort, irritation, or certain asymptomatic nonsensory effects. However, the effects are not disabling and are transient and reversible upon cessation of exposure.
- AEGL 2: The airborne concentration of a substance above which it is predicted that the general population, including susceptible individuals, could experience irreversible or other serious, long lasting adverse health effects or an impaired ability to escape.
- AEGL 3: airborne concentration of a substance above which it is predicted that the general population, including susceptible individuals, could experience life-threatening health effects or death.

Table 4.15-2 provides the AEGLs for the chemicals of concern, with an exposure duration of one hour. The severity of these effects is dependent on the level of exposure, the duration of the exposure, and individual sensitivities to the various chemical compounds. Table 4.15-2 also describes chemical occupational exposure limits, potential exposure routes, organs targeted by the compounds, and the range of symptoms associated with exposures to these chemicals.

Table 4-15-2 Properties and Hazards Associated with Chemicals of Concern

Chemical (CAS Number)	Exposure Limits and Guidelines				Exposure Routes	Target Organs	Symptoms
	Workers		General Population				
	Criteria (exposure period)	Air Conc. (ppm) ¹	Guideline (1 hour exposure)	Air Conc. (ppm) ²			
Ammonium hydroxide (1336-21-6)	NIOSH REL (10 hr.): OSHA PEL (8 hr.): NIOSH STEL (15 min.): IDLH:	25 50 35 300	Odor threshold: AEGL-1: AEGL-2: AEGL-3:	50 61 330 2,300	Skin and eye contact, Inhalation, Ingestion	Eyes: Skin: Nose and throat: Lungs:	Irritation, eye damage (liquid, vapors); Irritation, redness, higher exposure: burns; Irritation (vapors); Irritation, higher exposures: build-up of fluid in the lungs (pulmonary edema) (vapors) and death
Carbon Dioxide (124-38-9)	NIOSH REL (10 hr.): OSHA PEL (8 hr.): NIOSH STEL (15 min.): IDLH:	5,000 5,000 30,000 40,000	Odor threshold: AEGL-1: AEGL-2: AEGL-3:	None 30,000 30,000 50,000	Skin and eye contact (liquid, solid), Inhalation	Eyes and skin: Nervous, Respiratory, Cardiovascular systems	Irritation, burns, frostbite (liquid or solid) Headache, dizziness, tremors, personality changes, loss of vision, difficulty breathing, suffocation, convulsions, coma and death.
Carbon Monoxide (630-08-0)	NIOSH REL (10 hr.): OSHA PEL (8 hr.): NIOSH STEL (15 min.): IDLH:	35 50 200 1,200	Odor threshold: AEGL-1: AEGL-2: AEGL-3:	None 83 83 330	Skin and eye contact (liquid), Inhalation	Cardiovascular system, lungs, blood, central nervous system	Headache, dizziness, lightheadedness, fatigue, sleepiness, hallucinations, convulsions, heart and nervous system damage, forms <i>carboxyl-hemoglobin</i> – decreased blood oxygenation, trouble breathing, collapse, convulsions, coma and death.
Chlorine (7782-50-5)	NIOSH REL (10 hr.): OSHA PEL (8 hr.): NIOSH STEL (15 min.): IDLH:	0.5 1 1 10	Odor threshold: AEGL-1: AEGL-2: AEGL-3:	0.2 to 0.4 0.5 2 20	Skin and eye contact (liquid or gas), Inhalation	Skin and eyes: Nose and throat: Respiratory tract, lungs:	Severe irritation, burns, eye damage, frostbite (liquid), Severe irritation, coughing, wheezing; Severe shortness of breath, pulmonary edema, lung damage, headache, dizziness, nausea and vomiting, and death.
Hydrogen (1333-74-0)	NIOSH REL (10 hr.): OSHA PEL (8 hr.): NIOSH STEL (15 min.): IDLH:	-- -- -- --	Odor threshold: AEGL-1: AEGL-2: AEGL-3:	None 65,000 230,000 400,000	Skin and eye contact, inhalation	Skin and eyes: Respiration and systemic absorption:	Severe frostbite Very high levels can displace oxygen and causing suffocation. Symptoms: headache, dizziness, weakness, loss of coordination and judgment, loss of consciousness and death.

Table 4-15-2 Properties and Hazards Associated with Chemicals of Concern

Chemical (CAS Number)	Exposure Limits and Guidelines				Exposure Routes	Target Organs	Symptoms
	Workers		General Population				
	Criteria (exposure period)	Air Conc. (ppm) ¹	Guideline (1 hour exposure)	Air Conc. (ppm) ²			
Hydrogen Sulfide (7783-06-4)	NIOSH REL (10 hr.): OSHA PEL (8 hr.): STEL (15 min.): IDLH:	10 20 5 100	Odor threshold: AEGL-1: AEGL-2: AEGL-3:	0.008 to 0.1 0.51 27 50	Inhalation, absorption through the Skin	Skin and eyes: Lungs and respiratory tract: Systemic exposure:	Irritation, redness, blurred vision, frostbite (liquid) Irritation, pulmonary edema Nausea, dizziness, confusion and trouble sleeping, v high levels: unconsciousness and death
Methanol (Methyl Alcohol) (67-56-1)	NIOSH REL (10 hr.): OSHA PEL (8 hr.): STEL (15 min.): IDLH:	200 200 250 6,000	Odor threshold: AEGL-1: AEGL-2: AEGL-3:	100 to 1,500 530 2,100 7,200	Inhalation, absorption through the Skin	Skin: Eyes: Resp. tract: Systemic:	Irritation, skin rash, dryness and redness Irritation, blurred vision and blindness Coughing, wheezing and/or shortness of breath Nausea, vomiting, diarrhea and abdominal pain, High conc.: headache, dizziness, drowsiness, fatigue, loss of consciousness and death. May damage the liver, kidneys and nervous system.
Propylene (115-07-1)	NIOSH REL (10 hr.): OSHA PEL (8 hr.): STEL (15 min.): IDLH:	-- -- -- --	Odor threshold: AEGL-1: AEGL-2: AEGL-3:	23 500 -- --	Inhalation, contact with liquid	Skin and eyes: Systemic:	Frostbite; High conc.: dizziness, lightheaded, loss of consciousness; displaces oxygen leading to suffocation; may damage the liver, heart and nervous system.

Table 4-15-2 Properties and Hazards Associated with Chemicals of Concern

Chemical (CAS Number)	Exposure Limits and Guidelines				Exposure Routes	Target Organs	Symptoms
	Workers		General Population				
	Criteria (exposure period)	Air Conc. (ppm) ¹	Guideline (1 hour exposure)	Air Conc. (ppm) ²			
Sulfuric acid (7664-93-9)	NIOSH REL (10 hr.): OSHA PEL (8 hr.): STEL (15 min.): IDLH:	1 1 -- 15	Odor threshold: PAC-1: PAC-2: PAC-3:	None 0.2 8.7 160	Skin and eye contact, inhalation of mists and vapors, ingestion	Skin and eyes: Respiratory tract: Gastrointestinal tract:	Corrosive: severe irritation and burns, may lead to blindness. Severe irritation, pulmonary edema, lung damage headache (mists and vapors) Nausea and vomiting, damage to teeth and stomach.

Source: NIOSH, 2011.

Key:

- IDLH = Immediately Dangerous to Life and Health.
- NIOSH = National Institute of Occupational Safety and Health.
- OSHA = Occupational Safety and Health Administration.
- PEL = Permissible Exposure Limit.
- REL = Recommended Exposure Limit.
- STEL = Short Term Exposure Limit
- TWA = Time-Weighted Average.

Accidental releases could occur during transportation, storage, transfer, or operations. Releases could occur during transportation of hazardous materials from accidents causing damage to the vehicle or shipping container. The potential causes for accidental releases from storage, transfer, and operations could include operator error, valve, or piping leakage, overfilling a tank, catastrophic structure failure, or vandalism. The amount of the release would relate to the cause and the mode of use (or container size). Generally, spills would be contained within the secondary containment structure of storage tanks. A sudden catastrophic failure of a storage tank could also result in material splashing outside the secondary containment. DOE evaluated publically available data on the overtopping of secondary containment structures as a result of catastrophic ruptures and determined that the splashover could be between 14% and 28% of the volume of the storage tank. Volatile chemicals would vaporize from a spill and could result in hazardous ambient concentrations in the vicinity of the release. Although all accidents were considered unlikely, the release scenarios identified were ranked according to relative probability. For this analysis, DOE considered two categories of events:

- (1) “**probability**” scenarios: those with higher relative probability (higher chance of occurrence than other scenarios) but lower impacts to the environment or human health; and
- (2) “**consequence**” scenarios: those with lower relative probability but the impacts to the environment or human health would be expected to be greater.

For example, the “consequence” scenario for a storage tank would be a catastrophic failure that would spill or release a maximum amount of material.

DOE also considered the frequency or probability of a release. Frequency refers generally to the rate at which events occur or are expected to occur over some measured interval (e.g., number of events per unit time, number of events per operation, or number of events per mile traveled). The probability of an event can be calculated if the frequency of the occurrence is known. Accidents were categorized as possible, unlikely, extremely unlikely, or incredible (see text box at right). When assessing potential accidents, DOE considered engineering design and controls, as well as available industry safety statistics. For this analysis, DOE identified sources of publically available information on frequency of accidental releases or used judgment to estimate the probability of occurrence.

Accident Categories and Frequency Ranges
Possible: Accidents estimated to occur one or more times in 100 years of facility operations (frequency $\geq 1 \times 10^{-2}$ /year).
Unlikely: Accidents estimated to occur between once in 100 years and once in 10,000 years of facility operations frequency from 1×10^{-2} /year to 1×10^{-4} /year).
Extremely Unlikely: Accidents estimated to occur between once in 10,000 years and once in 1 million years of facility operations (frequency from 1×10^{-4} /year to 1×10^{-6} /year).
Incredible: Accidents estimated to occur less than one time in 1 million years of facility operations (frequency $< 1 \times 10^{-6}$ /year).

DOE evaluated the consequences of a release or spill to the environment, including soils, groundwater and surface water and dispersion into the air. Spills generally involve acute or short term impacts if the spill is small or if the spilled material is recovered. Those in the immediate vicinity of a spill, particularly workers and emergency responders, are most at risk from acute or short-term exposures. Spills of hazardous materials can harm the function of the ecosystem; and

certain habitats, such as streams, marshes, wetlands, and similar environments are especially vulnerable. Many types of aquatic life are particularly vulnerable to hazardous materials that flow into waterways. Various harms from long-term or chronic exposure can occur for people, wildlife, aquatic life and plants from materials not recovered or rendered harmless and remaining in the environment. These impacts depend on the toxicity, concentration, and volume, along with the response to the spill and fate of the spilled materials.

Releases to the air occur when the material is a gas at ambient conditions or is volatile at normal environmental conditions. Gaseous materials are often used, stored, or transported under high pressure or temperature. DOE estimated the level of exposure to releases of hazardous materials to the air using the ALOHA (Areal Locations of Hazardous Atmospheres) air dispersion modeling software which is a Gaussian plume dispersion model that evaluates release source and meteorological parameters. ALOHA was developed by the EPA, the National Oceanic and Atmospheric Administration (NOAA) and the National Safety Council to model chemical releases and fire and explosion hazards involving hazardous chemicals for emergency responders and planners. Impacts of a release on workers and the public depends on the location of the release, the meteorological conditions (including atmospheric stability and wind speed and direction) and other factors. Atmospheric concentrations from an accidental release were calculated using a wind speed of 3.36 mph and atmospheric stability class F (which are considered conservative, stable conditions) and release duration of up to one hour.

To evaluate the consequences of a release of CO₂ from the pipeline, Denbury used Process Hazard Analysis Software Tool (PHAST), the Det Norske Veritas proprietary software. PHAST is also a Gaussian plume dispersion model that incorporates continuous source and meteorological parameters. In 2011, the U.S. DOT Pipeline and Hazardous Materials Safety Administration (PHMSA) approved the use of PHAST as a vapor dispersion model (PHMSA 2011).

DOE estimated the potential population exposed to the three AEGLs for each chemical of concern evaluated based on the dispersion modeling and the population density (presented in Section 3.13) within the distance of the predicted impact.

4.15.2 LCCE Gasification Plant

As described in Section 2.3.1.1, the GE Quench Gasifier system is an oxygen-blown high pressure slurry-fed gasifier utilizing shift reactions to produce the syngas. Much of the equipment upstream (e.g. Air Separation Unit) and downstream of the gasifier and its downstream processing train (e.g. utilities) is in common use in the petroleum refining industry and does not pose any unique hazards (DOE, 2006). This analysis evaluates accidental spills and releases of the chemicals of concern associated with storage and transport and with operation of the gasifiers. These activities are evaluated and described separately below.

DOE evaluated potential release scenarios for the LCCE Gasification plant and Lake Charles CO₂ capture and compression equipment based on discussions with Leucadia regarding design and operation, professional judgment, comparison with prior DOE analyses, and an iterative modeling process to characterize potential scenarios for spill and releases.

4.15.2.1 Storage, Handling, and Transport

LCCE Gasification would require storage, handling, and transport of significant quantities of ammonia, chlorine, methanol, and sulfuric acid. Figure 2.3-2 provides the LCCE Gasification plant layout and identifies the locations of major components of the gasification process. The methanol and sulfuric acid off-site storage area would be located within 1 mile of the LCCE Gasification plant site.

Materials would be transported to and from the LCCE Gasification plant using various modes of transportation. Ammonia would be delivered to the site in tank trucks. Chlorine would be delivered in one ton cylinders on trucks. Methanol and sulfuric acid would be transported to and from storage tanks via underground pipelines and from the storage tanks in trucks, rail cars, barges, and ships, as described in Section 2.5.1. Figure 3.10-1 shows the transportation infrastructure in the vicinity of the Lake Charles CCS project and the LCCE Gasification plant. Interstate 10, a principal arterial highway located approximately 3 miles north, would provide primary regional access to the site. Local roads include State Highway 108, State Highway 27, Ruth Street, and Bayou D’Inde Road. The site is located adjacent to the Port of Lake Charles for shipment of products by barge or ship. Although a rail spur is not currently located on the site, there are railroad spurs within one half-mile of the site that could be accessed for shipping of products.

DOE evaluated available literature on the frequency of incidents for the various transportation and storage modes that could be used at the LCCE Gasification plant. Table 4.15-3 provides a summary of incident rates and accident categories for each mode of transport and storage.

Table 4.15-3 Incident Rate and Accident Categories for Transport and Storage

Mode	Incident Rate	Accident Category
Truck	3.2×10^{-7} / mile ^a	Incredible
Railcar	2.25×10^{-10} / tons mile ^b	Incredible
Barge	5.59×10^{-9} / tons ^c	Incredible
Ship	5.59×10^{-9} / tons ^c	Incredible
Hazardous Material Pipeline	1.5×10^{-3} / mile ^d	Unlikely
Storage Tank	5.0×10^{-6} / tank/yr ^e	Extremely Unlikely

Sources:

- ^a Table 25, Battelle 2001, Comparative Risks of Hazardous Materials And Nonhazardous Materials Truck Shipment Accidents/Incidents, and Nonhazardous Materials Truck Shipment Accidents/Incidents
- ^b DOE estimated incident rate using Table 1122. Railroads, Class I—Summary, US Census Bureau, The 2012 Statistical Abstract, The National Data Book and 10 Yr (2003-2012) and PHMSA Incident Data Base Based On Hazardous Materials Incident Report Form 5800.1 at <http://www.phmsa.dot.gov/hazmat/library/data-stats/incidents>
- ^c DOE estimated using incident rate using Table 1085. Waterborne Commerce by Type of Commodity, US Census Bureau, The 2012 Statistical Abstract, The National Data Book and 10 Yr (2003-2012) PHMSA Incident Data Base Based On Hazardous Materials Incident Report Form 5800.1 @ <http://www.phmsa.dot.gov/hazmat/library/data-stats/incidents>
- ^d DOE 2012
- ^e Thyer et al. 2002, 2009; and Atherton 2005

DOE assessed the potential frequency and probability for which an accidental release could occur for each mode of storage and transportation. Table 4.15-4 summarizes the anticipated modes of transportation, frequencies of transport or use, reported, estimated incident probabilities, and the associated chemicals of concern. Not all modes would be used simultaneously. This estimate is based on the incident rates in Table 4.15-3 and current

Table 4.15-4 Summary of Estimated Incident Probabilities for the LCCE Gasification Plant for Each Mode of Transport and Storage

Transportation Vessel	Units	Miles per Year	Tons per Year	Design Life (years)	Total Trips	Total Miles (30 yrs)	Total Tons ^b (30 yrs)	Incident Frequency	Frequency Units	Probability of Occurrence ^c
Tanker Truck	2160 trips per year ^a	1.30E+04		30	6.48E+04	3.89E+05		3.20E-07	Incidents per mile	1.24E-01
Railcar	1680 trips per year		2.30E+02	30	5.04E+04		1.16E+07	2.25E-09	Incidents per ton per mile	2.61E-02
Barge	240 trips per year		3.83E+01	30	7.20E+03		2.76E+05	5.59E-08	Incidents per ton	1.54E-02
Ship	12 trips per year		2.00E+04	30	3.60E+02		7.20E+06	5.59E-08	Incidents per ton	4.03E-01
HM pipelines	2 miles			30				1.5E-03	Incidents/100 miles/ yr	4.5 x 10⁻²
AST	20 tanks			30				5.0E-06	Rupture/tank/yr	3.0 X 10⁻³

- ^a Estimated as number of trips to I-10 is based on a 6-mile trip from I-10 to the Site. Transportation along I-10 is not considered in the analysis because of the overwhelming number of loads being transported on the interstate.
- ^b Tons were estimated using sulfuric acid at 68 degrees Fahrenheit and density of 114.59 pounds per cubic foot. The probability of occurrence of a spill of methanol would be half that of sulfuric acid.
- ^c DOE estimated the probability of occurrence by multiplying the total number of miles or tons over the 30 year life of the project by the incident frequency for each mode of transportation. Incident frequencies are described above in Table 4.15-3.

operational information assuming the highest estimated use of any mode of transportation during the 30-year operating life of the LCCE Gasification plant. The probabilities of an incident with the potential for impacts to human health and the environment are low, ranging from possible (10^{-1}) to unlikely (10^{-3}).

The transport and storage release scenarios evaluated by DOE and the potential consequences for the chemicals of concern are described below. Appendix F provides the ALOHA modeling input data, the release scenarios considered, and modeling results.

Aqueous Ammonia

Aqueous ammonia would be stored in two 33,000 gallon above-ground storage tanks for use in the NO_x emissions reduction system. Transfer from the delivery truck to the storage tanks would occur in a curbed transfer area, located within a secondary containment area to minimize the risk of spills during transfer. DOE considered a leak from a pipe flange during loading of the tank as the higher probability, but low consequence event.

DOE evaluated a spill resulting from tank failure. Ammonia storage tanks would be equipped with secondary spill containment structures sized to contain at least 120% of the working volume of the largest storage container. In the event of a spill, ammonia would vaporize and could result in hazardous ambient air concentrations of ammonia in the vicinity of the release. Although catastrophic rupture of an aqueous ammonia storage tank is unlikely, the potential spill would include liquid inside the containment area, as well as splashover onto the area outside containment (due to the energy of such a failure). Literature searches revealed a range of splashover volumes, the highest of which was 28%. Applying this to the ammonia tank, 23,800 gallons would be spilled inside containment and 9,200 gallons could splash onto soil outside containment. Because the surface area of the spill pool within secondary containment is smaller than for some other spill scenarios and because the population density is low in the area surrounding the plant site, this type of accident is not considered to be the highest consequence event for aqueous ammonia. DOE evaluated a spill of 7,000 gallons of aqueous ammonia from a tanker truck during transport on a public road. Because this could occur in a location of a higher population density than the plant site, it is considered the potentially higher consequence event.

Assuming the aqueous ammonia spill occurs from a tanker truck during transport, it could accumulate in the soil, accumulate as a pool on the ground surface, and vaporize to the air. The ecological impact of a release of aqueous ammonia to groundwater, surface water, and soil would be highly dependent on each water body's physicochemical characteristics and the presence of sensitive bioreceptors. Release of liquid ammonia from a container at 15°C to soils would initially result in production of gaseous ammonia. The estimated concentrations of ammonia vapor are discussed below. Vegetation would be severely damaged or killed. The extent of the damage would depend on the resistance of the individual plant species to ammonia and the time of year that the spill occurred. Perennial species in natural flora would be most affected by the ammonia in the summer and early fall when they are under the greatest physiological stress due to low soil moisture. Annual species would not be affected to this degree because most seeds are resistant to ammonia. Plants exposed to lower concentrations in downwind areas could experience leaf damage, with long term impacts including reduced growth rates. Birds exposed to higher concentrations of gaseous ammonia could exhibit irritated mucous membranes of the respiratory tract or other similar problems. Damage to the mucous membranes

of the respiratory system could increase the susceptibility of birds to future bacterial respiratory infections.

Although ammonia strongly adsorbs to soil and sediment particles (HSDB, 2001), a release of aqueous ammonia to soils could be converted to nitrate by in situ bacteria. Nitrates are very mobile and can be taken up by plants and microorganisms (ATSDR, 2000), but, because of their mobility, nitrates could possibly impact groundwater. It is expected that a one-time release would not result in significant or long term input of nutrients to groundwater.

Spills of liquid ammonia to water would be more critical than to land. Although liquid ammonia floats on water, it will rapidly dissolve into a water body to form ammonium (ionized ammonia), hydroxide and un-ionized ammonia. Ammonium is considered non-toxic to aquatic life; however un-ionized ammonia can easily cross cell membranes and could have a toxic effect on a wide variety of fish (Lindberg 2003). In general, un-ionized ammonia toxicity is greater at higher temperature and pH, and at lower levels of dissolved oxygen and salinity. At a concentration of 0.02 mg/L (48 hour LC50) un-ionized ammonia is lethal to some sensitive freshwater fish. Un-ionized ammonia is also highly toxic to freshwater invertebrates, with a 48-hour LC50 of 0.66 mg/L for *Daphnia magna*, as an example.

To predict the concentrations expected from a spill onto surface waters a rudimentary model from the University of Pittsburgh (2002) was applied. The amount of ammonia that dissolves into a receiving water body, or the partition ratio, is normally between 0.5 and 0.8 (average of 0.6) for surface spills (Pitt, 2002). For a spill into a water body such as the Calcasieu River, it would be expected that the spill would advance at approximately 0.2 ft/sec as it moves downstream (Pitt, 2002). Although specific calculations of the Calcasieu River basin were not made for this assessment, it was assumed that surface flow would take un-ionized ammonia from a 1 ton (390 gal.) spill downstream at a 0.2 ft/sec flow rate (considering a partition ratio of 0.6, this would be approximately 233 gallons). Un-ionized ammonia concentrations near the spill point are predicted to nominally be greater than 10 ppm but less than 100 ppm. As the spill material moves down stream concentrations will be inversely proportional to the distance from the spill site, so that within a half mile, concentrations will likely drop to between 2 and 10 ppm, and after 2 to 3 miles, concentrations would be undetectable. The time for the spill to reach this point could be between 6 to 10 hours, and concentrations would likely result in a major fish (and invertebrates) kill within that portion of the river. Water fowl exposed to these concentrations may be affected by removal of protective oils from feathers. Birds could have long term repercussions from these effects such as drowning or infection.

As shown in Table 4.15-5, AEGl 3 concentrations for human exposure would occur at approximately 581 yards (1/3 mile) during the consequence scenario if appropriate corrective actions were not taken.

Table 4.15-5 Estimated Consequences of Aqueous Ammonia Release Scenarios

	Probability Scenario			Consequence Scenario		
	Leaking flange during loading for 60 minutes			Loaded truck complete 7,000-gallon spill		
	AEGL 3 Distance	AEGL 2 Distance	AEGL 1 Distance	AEGL 3 Distance	AEGL 2 Distance	AEGL 1 Distance
Distance (yards)	166	462	1,095	581	1,936 (1.1 mile)	4,928 (2.8 mile)
Population Density	Worker	Worker	Worker and non-involved worker	Worker	0-726	0-726

Leucadia’s hazardous materials management program would include training on proper aqueous ammonia handling and spill response procedures and personnel at the facility would have radio communications to the control room where an emergency system would be activated. The fire water system would be used for vapor suppression in the event of an ammonia leak or spill. In addition to the spill and release prevention procedures described in Section 4.12 and 4.13, these measures would be expected to reduce the probability and consequences of an accidental release of ammonia.

Chlorine

Chlorine would be delivered in one ton pressurized steel cylinders by truck and stored in an enclosed building equipped with a chlorine scrubbing system. Minor leaks may occur during connection of the cylinder to valves or from a faulty valve. The scrubbing system would be activated upon release of chlorine to prevent a release to the environment. However, a release was assumed to occur if the scrubbing system would be exhausted before the release was completely contained. A major release could occur if a cylinder is punctured or damaged. DOE evaluated a 300-pound release of chlorine gas from a single cylinder valve inside the controlled storage building as the higher probability, low consequence scenario and a 2000 pound release of chlorine gas from a single cylinder valve outside the controlled building as the higher consequence, low probability scenario.

Chlorine gas is approximately 2.5 times heavier than air, so chlorine gas would settle to the lowest level in an area before dispersing. As shown in Table 4.15-6, in the higher probability scenario, AEGL 3 levels of chlorine would occur within 1,173 yards (0.67 miles) of a release if appropriate corrective action were not taken. The potential population density affected ranges from 0 to 128. In the higher consequence scenario, AEGL 3 levels of chlorine would occur within 1 mile of a release. The potential population density affected during the higher consequence scenario ranges from 0 to 726.

The hazardous materials management program would include the installation of chlorine detectors and a chlorine scrubbing system on the building storing chlorine cylinders to mitigate any potential releases. During loading and unloading activities, risk of a release would be minimized by following safe cylinder handling protocols, such as provided by Uniform Fire Code (UFC) Article 80. Leucadia would also use protective valve covers in all on-site and in-transit tanks to minimize the potential for damage and accidental leaks. Chlorine cylinder emergency repair kits would be available on site, and operators would be trained to respond to and control chlorine releases. In addition, the plant fire water system would be used for vapor suppression in the event of a chlorine leak or spill. In addition to the spill and release prevention

procedures described in Section 4.12 and 4.13, these measures would be expected to reduce the probability and consequences of an accidental release of chlorine.

Table 4.15-6 Estimated Consequences of Chlorine Release Scenarios

	Probability Scenario			Consequence Scenario		
	300 lb. release from leaking valve inside controlled building (scrubber system in use during release)			2000 lb. release from loss of fusion plug or from cylinder outside the controlled building.		
	AEGL 3 Distance	AEGL 2 Distance	AEGL 1 Distance	AEGL 3 Distance	AEGL 2 Distance	AEGL 1 Distance
Distance	1173 yards	2 miles	3.5 miles	1.0 mile	3.0 miles	5.7 miles
Population Density	0-128	0-726	0-726	0-726	0-726	0-1,638

Methanol

Methanol would be produced by the LCCE Gasification plant and stored on site in six tanks of approximately 1.6 million gallons each and off-site in four 7.5 million gallon tanks. Transfer of methanol to delivery trucks would occur in a curbed transfer area located within a secondary containment area. Methanol could be released due to a leak or catastrophic rupture of the buried transfer pipelines used to deliver methanol to the off-site storage area or from the off-site storage area to the Port of Lake Charles. As methanol vaporizes, it could result in hazardous ambient concentrations of methanol in the vicinity of the release. Methanol vapors are mobile and flammability is similar to most motor fuels.

DOE evaluated a release from a tanker truck belly valve shear inside the secondary containment as the higher probability scenario and a release of 7.5M gallons of methanol from a complete rupture of an off-site methanol storage tank within the secondary containment area resulting in a fire as the higher consequence scenario. In the storage tank release scenario, it is assumed that a spark would ignite the methanol vapors, creating a fireball. Methanol storage locations would be equipped with secondary spill containment structures sized to contain at least 120% of the working volume of the largest container. Although sudden rupture of a methanol storage tank is unlikely, the potential splashover could result in a spill outside containment of 28% of the tank contents, or 448,000 gallons for the onsite tanks and 2,100,000 gallons for the off-site tanks. Although considered extremely unlikely, DOE also addressed a 6 million gallon methanol release from a tanker ship at the Port of Lake Charles. Because of the methanol’s 100% solubility in water air modeling of this scenario was not considered; impacts to water are discussed below.

A large spill of methanol has the potential to affect soil, surface water, groundwater, and intertidal marsh habitat (Dolan, 2012). In the atmosphere, methanol would be photooxidized relatively quickly with reported half-lives ranging from 3 to 30 days. Numerous studies have reported that methanol is not persistent in the environment because it readily degrades in air, soil, and water and has no persistent degradation intermediates (ENVIRON 1996; Deeb et al. 2013).

For a spill onto soil, several processes are important for determining the fate and potential impact. First, methanol would be a major source of carbon for microorganisms that live in soil (NRC 1993). As such, it is expected that they would play a major role in early biodegradation of

methanol. The highly organic, and highly nutrient-laden, nature of soils near the Project site (e.g., loams) would likely enhance natural biodegradation processes and act to retard its movement into groundwater. Both aerobic and anaerobic microbial activity would be enhanced by the presence of a large carbon source such as methanol. Although transfer into groundwater from a large spill is possible, advection processes along with biodegradation within upper soil horizons would be the dominant mechanisms for reduction of methanol concentrations. Seasonal temperatures would be important for determining the speed of microbial action. Warm temperatures would act to enhance microbial activity in soil and limit groundwater impacts. Spills to soil would likely affect vegetation in the immediate impact area, but long term effects are not expected. Because of the depth of groundwater in the area, and the degradation processes that will reduce methanol concentrations, it is expected that impacts to this resource will not occur.

A methanol spill to moving surface waters would rapidly decrease in volume because of advection and dispersion. Because of methanol's infinite solubility in water, it would disperse to nontoxic levels at a rate much faster than equivalent volumes of petroleum products such as gas or diesel. The rate of dispersion is directly proportional to the amount of turbulent mixing in an aquatic environment. The nature of the water bodies near the site would quickly enhance mixing and reduction of methanol concentrations. Hypothetical simulations have shown that spills up to 3 million gallons in the open sea exhibited concentrations less than 1% within two hours, and 0.13% within three hours after the spill ceased. A study by Jamali et al. (2002), on the fate of methanol spills into rivers of various sizes and geometry, found that a 30,000 gallon spill into a small ($10 \text{ m}^3/\text{s}$) river resulted in concentrations below 10,000 ppm less than 2 kilometers from the spill location. Potentially lethal concentrations (LC_{50}) for various species in environments similar to the Calcasieu River and Bayou D'Inde have ranged from 15,400 ppm to 28,000 ppm for carp, bluegill and fathead minnows (see Malcolm Pirnie, Inc. 1999), with NOECs (no observed effect concentration) near 24 ppm. Based on Jamali et al. (2002), concentrations similar to LC_{50} values would only be found very close (<3 km) to the original spill site; concentrations downstream would all be lower. Based on this information, it is predicted that fish near the spill point would be at risk, but this risk would quickly be reduced as degradation of methanol proceeds both in time and space. Also, it must be emphasized that fish typically avoid waters that are atypical to their natural surroundings. It is predicted that juvenile and adult fish in the immediate area of the spill would be at risk, but that they would quickly disperse from the area as methanol concentrations increase in the water column. Larval or pre-juvenile fish would be at highest risk to exposure, and thus the seasonal aspect of a spill would be important to determining overall impacts.

Considering a large spill of methanol, such as the 2.1 million gallon splashover or a complete loss of a ship containing 6 million gallons, it is assumed that the major form of remediation would be natural attenuation (i.e., dilution). Based on the Calcasieu River's approximate 41,000 gal/min discharge rate, it would take approximately one hour for the 2M gallons spill to obtain a 50% methanol concentration. After 4 hours the methanol concentration would be less than 10%. This suggests that for a methanol spill of this size, natural attenuation would be the best remedial option. It is assumed that there would be fish and invertebrates killed in the immediate spill area, and others anesthetized to some degree as the methanol concentration diminishes, but it is likely that short term effects would not be critical, and long term effects are predicted to be minor. A similar size spill within Bayou d'Inde would affect the biotic population more directly, as most

of the stream’s channel would initially have high methanol concentrations. But, as the spill plume moves toward the confluence with the Calcasieu River, effects would diminish substantially and fate would be similar to that discussed above.

The air impacts of a release from a tanker truck belly valve shear inside the secondary containment and a release of 7.5M gallons of methanol from a complete rupture of an off-site methanol storage tank within the secondary containment were evaluated. As shown Table 4.15-7, the AEGL 3 levels of methanol vapors occur within 11 yards of a tank truck release if appropriate corrective actions were not taken. In the consequence scenario, life-threatening thermal radiation levels from fire occur within 83 yards. No life-threatening levels of the methanol release would be expected to extend outside the LCCE Gasification property in any scenario.

Table 4.15-7 Estimated Consequences of Methanol Release

	Probability Scenario			Consequence Scenario		
	Tanker Truck with leak released inside secondary containment			Complete release of 7,500,000 gallons inside secondary containment, resulting in a fire		
	AEGL 3 Distance	AEGL 2 Distance	AEGL 1 Distance	60 sec Fatal Fire Ball Radius	60 sec 2° Burns Radius	60 sec Pain Radius
Distance (yards)	<10.9 ^a	<10.9 ^a	<10.9 _a	142	183	260
Population Density	Worker	Worker	Worker	Worker	Worker	Worker

^a Minimum distance calculated by ALOHA

Leucadia would design the methanol storage tanks to comply with applicable standards of the NFPA 1 (Uniform Fire Code) and NFPA 30 (Flammable and Combustible Liquids Code), as well as American Petroleum Institute and ASTM specifications. The carbon steel tanks would be equipped with coatings and cathodic protection to minimize corrosion. Leucadia would control potential ignition sources near methanol liquid storage tanks by considering provisions for siting, electrical grounding, berming, flame arresters, and safeguarding above ground storage tanks containing flammable liquids. Storage areas would be equipped with appropriate fire suppression systems. In addition to the spill and release prevention procedures described in Section 4.12 and 4.13, these measures would be expected to reduce the probability and consequences of an accidental release of methanol.

Sulfuric Acid

Sulfur contained in the pet coke would be oxidized during gasification, removed from the syngas, and converted to a sulfuric acid product by the WSA. Sulfuric acid would be stored in six 560,000-gallon tanks with liners located on-site adjacent to the WSA unit and off-site in two 1.9 million gallon tanks. Transfer of sulfuric acid to delivery trucks would occur in a curbed transfer area, located within a secondary containment area to minimize the risk of spills to the environment during transfer. Sulfuric acid could be released due to a leak or catastrophic rupture of the buried transfer pipelines used to deliver sulfuric acid to the off-site storage area or from the off-site storage area to the Port of Lake Charles.

Sulfuric acid has a boiling point of 554 degrees Fahrenheit and a vapor pressure of 0.001 millimeters of mercury, and thus is not very volatile. A sulfuric acid release at the facility would not be expected to result in an airborne mist or aerosol, nor result in a fire, thus impacts to the air

from a release were not modeled. Sulfuric acid storage locations would be equipped with secondary spill containment structures sized to contain at least 110% of the working volume of the largest container. Although sudden catastrophic rupture of a sulfuric acid storage tank is unlikely, the potential splashover could result in a spill outside secondary containment of 28% of the tank contents, or 154,000 gallons for the onsite tanks and 532,000 gallons for the off-site tanks. Although considered as very unlikely, DOE also addressed a 2.9 million gallon sulfuric release from a tanker ship.

The toxicity associated with a sulfuric acid spill is primarily a function of the resulting pH. Sulfuric acid is completely soluble in water. Its fate in soils is based on whether the soil is dry or wet. Sulfuric acid spilled onto dry soil is mobile, and this mobility increases as water content increases. Sulfuric acid does not adsorb onto particulate matter or surfaces and thus does not accumulate in living tissues. Generally, the pH of acids are neutralized by reaction with soil minerals (Denham, 1998). The acid is not biodegraded by microbial activity, but instead its concentration is reduced by volatilization and solubility in water. Acute effects to vegetation, soil, fauna and less mobile terrestrial species, in areas where sulfuric acid is spilled, would likely result in instantaneous death. Fumes from an acid spill would result in respiratory effects to local biota and long term effects could occur if the animal is exposed to high concentrations and for an extended period of time. Impacts during warm, seasonal periods would likely be greater than during winter and fall seasons. It is expected that affected soils would remain contaminated until seasonal rains or inundation flushes away the residual acid and the microbial community recovers. Groundwater impacts are not expected based on depth to groundwater near the site. As noted above, the solubility factor and subsequent increase in pH would likely be ameliorated during transit time to groundwater resources.

As discussed above, impacts to aquatic resources from a sulfuric acid spill will be dependent on the subsequent pH conditions that occur within the system. Trent et al. (1978) conducted laboratory experiments on freshwater taxa similar to those found near the site. Generally, they found that most species were killed at a pH of 3 within a 24 hour exposure period, but a UNEP (2001) study found that fish growth can become inhibited at a pH of 6. Mortality to small invertebrates (scud and shrimp) occurred at pH of 5 (Trent et al. 1978). A moderate (50,000 gallon) sized sulfuric acid spill into the Calcasieu River would result in mortality to those individuals within the immediate spill area. Based on the nominal flow rate in the river, 92 ft³/sec [41,300 gal/min], it would be expected that surface water pH would be lowered immediately, but advection and dissolution would also be immediate and the drop in pH would quickly rise as more river water infuses the spill plume. Within 10 minutes the spill volume would comprise approximately 10% of the moving plume, and the pH will have risen by one unit.

Considering a large spill of sulfuric acid, such as the 532,000 gallon splashover or a complete loss of a ship containing 2.9 million gallons, the major form of remediation would be natural attenuation (i.e., dilution). A 2.9 million gallon spill of concentrated sulfuric acid (assuming an initial pH of 1) would require 29 million gallons of dilution water to increase its pH to 2. Based on the Calcasieu River's approximate 41,000 gal/min discharge rate, it would take over 12 hours for the initial plume to be raised one pH unit. This suggests that for a spill this large it would take almost 5 days of flow before a pH of 3 was obtained. This indicates that a very large portion of the downstream basin could be affected by a sulfuric acid spill of this size. There is a

high probability that a spill of this magnitude would cause a substantial fish kill. Although emigration of like taxa in other, non-affected, waterways would quickly result in re-population of those areas affected, local fishery populations (and their food base) would be modified substantially. Local, sensitive habitat could be affected long term, but it is likely that vegetation would be restored during the next growing season. No residual chemical effects from sulfuric acid in the system would be expected. A similar size spill within Bayou d'Inde would devastate habitat and taxa found from the spill site down to the confluence with the Calcasieu River, from that point effects would be similar to those noted above. Because of the narrow channel, it is expected that riparian areas along the bayou would be critically affected also.

Leucadia would design the sulfuric acid storage tanks to comply with applicable standards of the American Petroleum Institute and ASTM specifications. The carbon steel tanks would be equipped with coatings to minimize corrosion. In addition to the spill and release prevention procedures described in Section 4.12 and 4.13, these measures would be expected to reduce the probability and consequences of an accidental release of sulfuric acid.

4.15.2.2 Operation

Specific accident probability and frequency data for gasifier operations are not available. For the analysis of potential accidents with releases of chemicals of concern during operation, DOE compared the LCCE Gasification plant and Lake Charles CCS processes (see Figure 2.3-3) with the processes evaluated in the comprehensive risk assessment for the FutureGen Project. The FutureGen Project included similar gasification technology, glycol based CO₂ capture, a CO₂ pipeline, and sequestration in a saline aquifer. DOE characterized and evaluated potential impacts from accidental releases of toxic and/or flammable gases from four candidate gasification processes, including the GE gasifier (DOE 2006). Given the similarities in the overall project design and specific operations, the results of the FutureGen risk assessment are illustrative of the potential probabilities and consequences (risks) from operation of the proposed LCCE Gasification plant and Lake Charles CCS project. DOE performed this comparative analysis with Leucadia to identify similarities and differences in processes and equipment and to identify the “higher probability” and “higher consequence” release scenarios as defined in 4.15.2 above.

During operation, LCCE Gasification would generate H₂S, CO, methanol, and H₂ gas. The potential consequences of releases of H₂S, CO, and H₂ gas are evaluated below. The risk of an accidental release of methanol from storage would represent a higher consequence scenario relative to the risk during operation and was evaluated above in 4.15.2-1. The operations related release scenarios evaluated by DOE and the potential consequences for the chemicals of concern are described below. Appendix F provides the ALOHA's modeling input data, the release scenarios considered, and modeling results.

DOE evaluated a release of H₂S from the piping of syngas to the quench process as the higher consequence scenario. As shown in Table 4.15-8, the AEGl 3 levels of H₂S occur within 642 yards, if appropriate corrective actions were not taken. The potential population densities that could be affected during a higher consequence release of H₂S ranges from 0 to 726.

For a release of CO, the higher consequence scenario results in AEGL 3 levels within 375 yards of the release, if appropriate corrective actions were not taken. No life-threatening levels of CO would be expected to extend outside the site in the scenarios evaluated.

DOE evaluated a release of H₂ from catastrophic pipe rupture resulting in a torch fire as the consequence scenario. As shown in Table 4.15-8, AEGL 3 thermal radiation levels would occur within 16 yards of a release if appropriate corrective actions were not taken. However, no thermal radiant effects would be expected to extend outside the site.

Table 4.15-8 Estimated Consequences of Hydrogen Sulfide, Carbon Monoxide, and Hydrogen Release Scenarios for the LCCE Gasification Plant

	H₂S Consequence Scenario		
	Gasification: Syngas from Quench		
	AEGL 3 Distance	AEGL 2 Distance	AEGL 1 Distance
Distance (yards)	642	852	5,280 (3.0 miles)
Population Density	Worker and non-involved worker	Worker and non-involved worker	0-762
	CO Consequence Scenario		
	Gasification: Syngas from Quench Max quantity		
	AEGL 3 Distance	AEGL 2 Distance	AEGL 1 Distance
Distance (yards)	375	945	None Detected
Population Density	Worker	Worker and non-involved worker	0
	H₂ Consequence Scenario		
	Gasification: Syngas from Quench and assumes that ignition occurs		
	60 sec Fatal Fire Ball Radius	60 sec 2° Burns Radius	60 sec Pain Radius
Distance (yards)	16	23	35
Population Density	Worker	Worker	Worker

Leucadia would install and operate CO and H₂S monitors, thus allowing trained facility operators to identify a release. H₂S monitors would be set at the OSHA permissible “ceiling” exposure limit of 20 ppm and CO monitors will be set at the OSHA permissible exposure limits of 50 ppm (8 hour time weighted average). In addition, all personnel, including visitors, would be required to use personal H₂S detectors, with the capability to detect H₂S at a 10 ppm concentration. Early release detection would allow for rapid response by operators to isolate the affected pipe segments and minimize the scale and impact of a release. Also, the response to this type of release would involve emergency procedures to activate engineering controls and emergency shutdown systems to reduce the volume released. Isolation of the affected units, piping, and/or valves would be implemented immediately.

Like most fuels, hydrogen can be handled and used safely with appropriate sensing, handling, and engineering measures. Leucadia would construct and handle hydrogen operations in accordance to the National Fire Protection Association (NFPA) 2: Hydrogen Technologies Code (Current Edition: 2011). The purpose of this code is to provide fundamental safeguards for the generation, installation, storage, piping, use, and handling of hydrogen in compressed gas (GH₂) form or cryogenic liquid (LH₂) form. This code applies to the production, storage, transfer, and

use of hydrogen in all occupancies. Overall, NFPA 2 aims to minimize the probability of hydrogen releases. The code is designed to ensure the appropriate use of quick and reliable detection systems (gas and fire) and shutdown, isolation and depressurization systems; prevent accumulation of hydrogen gas in pockets; avoid high levels of confinements; and promote natural ventilation and gas release to a safe location. In addition to the release prevention procedures described in Section 4.12 and 4.13, these measures would be expected to reduce the probability and consequences of accidental releases of CO, H₂S and H₂.

4.15.3 Lake Charles CCS Project

The Lake Charles CCS project would consist of the CO₂ capture and compression equipment, the CO₂ connector pipeline, and the West Hastings research MVA program.

For the analysis of potential accidents during operation of the CO₂ Capture and Compression equipment, DOE identified process operations that would produce the “higher probability” or “higher consequence” release as defined in 14.5.1 above. As indicated earlier, DOE evaluated potential release scenarios based on discussions with Leucadia regarding design and operation, professional judgment, comparison with prior DOE analyses, and an iterative modeling process to characterize potential scenarios for spill and releases.

DOE evaluated the potential CO₂ release from the 11.9 mile CO₂ pipeline as the potential higher probability of potential accidents during the transport, sequestration, and monitoring of CO₂. DOE considered previous analyses, operating statistics, and site specific information to identify potential release frequencies and scenarios. As indicated previously, DOE conducted a comprehensive quantitative risk assessment for the FutureGen Project. The evaluation considered the potential for CO₂ releases during pipeline operation, an injection well, through the caprock, through faults or undocumented wells, and through existing or induced faults with eventual releases to the surface. DOE’s assessment used a risk ratio to compare the concentration of a CO₂ release with health impact criteria. A risk ratio is the estimated exposure level of CO₂ predicted by modeling divided by the most appropriate health impact criterion. The modeling of the concentration of a CO₂ release considered the type of release, the quantity released, ambient conditions (such as wind direction and speed) at the time of the release, the land terrain, and constructed features (DOE 2007). The majority of activities show low probability or frequencies of occurrence for potential leakage of CO₂. The probabilities of a release over a 50-year operational lifetime ranged from 1 in 10 (0.1) for pipeline rupture, to 1 in 1,000 (0.001) for a wellhead failure. The estimated risk ratio values for pipeline puncture, pipeline rupture, and wellhead failure were 0.4, 0.5, and 0.07, respectively. The FutureGen analysis demonstrated that the event with the highest probability of occurring and the highest consequence was a pipeline rupture. The DOE analysis also examined potential releases associated with CO₂ sequestration, including slow leaks through caprock, migration through existing or induced faults, slow leaks through the injection wells, and low-rate leaks from undocumented wells. The risk assessment predicted that over the 5,000-year sequestration lifetime there would be a slow leak through undocumented wells (probability of 0.99); however, the consequences of that event were predicted to be quite small, resulting in a risk ratio of 0.002. Therefore, DOE considered potential CO₂ release scenarios for the CO₂ pipeline.

4.15.3.1 CO₂ Capture and Compression Facilities

The Lake Charles CCS Project would use two Lurgi Rectisol® AGRs to remove impurities from the syngas produced by the LCCE Gasification plant. The AGRs would use chilled liquid methanol (-70 degrees F) as a gas-washing solvent to remove H₂S, COS, CO₂, and trace impurities that are byproducts of syngas production. Two CO₂ gas compressors in parallel, one for each AGR unit, would contain 5,700 pounds of propylene refrigerant due to the heat generated during compression. The release scenarios evaluated by DOE for operation of the CO₂ Capture and Compression equipment and the potential consequences for the chemicals of concern are described below. Appendix F provides the ALOHA's modeling input data, the release scenarios considered, and modeling results.

Propylene would be transported to the facility one time at start-up and used in a closed system. As shown in Table 4.13-2, propylene would be stored in quantities that exceed the threshold quantity for the RMP rule. Available information regarding the frequency and probability of releases from refrigeration systems is mostly applicable to ammonia based refrigeration systems. Of the total of 2020 ammonia releases reported from 1993 to 1998 in 15 states in the US, 659 of these events (37 %) occurred with ammonia refrigeration equipment for food processing or storage facilities (2011 Jones). In a 2000 analysis of RMP accident data from 15,000 chemical facilities in the RMP program, EPA indicates that propylene is 2.7% of the total quantity of reported RMP chemicals. This analysis also indicates that out of 1,910 RMP accidents reported in EPA's RMPInfo database by chemical involved in an accident for the 1994-1999 period, propylene was only reported in 10 incidents (EPA 2000), or 5 in 10⁻³.

DOE evaluated propylene, H₂S and CO as representing the highest consequences scenarios. A release of H₂S from a leaky flange in the AGR to WSA train was selected as the higher consequence scenario for H₂S. As summarized in Table 4.15-9, AEGL 3 levels of H₂S would occur up to 232 yards from a release if appropriate corrective action were not taken. The potential population densities affected during this consequence scenario ranges from 0 to 726.

DOE evaluated a release of CO from a pipe connecting the AGR to downstream processing equipment. AEGL 3 levels of CO would occur 164 yards from a release if appropriate corrective action were not taken. No life-threatening levels of CO would be expected to extend outside the LCCE Gasification plant site.

DOE evaluated a release of 5,700 pounds of propylene from a catastrophic failure of one compressor pipe rupture resulting in a torch fire as the higher consequence scenario. As shown in Table 4.15-9, AEGL-3 thermal radiation levels occur within 11 yards of a release. However, no thermal radiant effects would be expected to extend outside the site.

As indicated, the capture and compression equipment would operate simultaneously with the LCCE Gasification plant. The spill and release prevention procedures described in Section 4.13 and in 4.15.2 above would be also be applied in the Lake Charles CCS operations.

As described in Section 4.15.2.2, Leucadia would have monitors for CO and H₂S. Leucadia would develop an RMP for storage, use and handling of propylene. In addition to the release prevention procedures described in Section 4.12 and 4.13, these measures would be expected to reduce the probability and consequences of accidental releases of CO, H₂S and propylene.

Table 4.15-9 Estimated Consequences of Hydrogen Sulfide, Carbon Monoxide, and Propylene Releases for Lake Charles CO₂ Capture and Compression

Chemical	H ₂ S Consequence Scenario AGR to WSA pipe release from leaky flange		
	AEGL 3 Distance	AEGL 2 Distance	AEGL 1 Distance
Distance	232	331	1.6 mile
Population Affected	Worker	Worker	0-726
	CO Consequence Scenario AGR pipe release to H ₂ and MeOH processing		
	AEGL 3 Distance	AEGL 2 Distance	AEGL 1 Distance
Distance	164	343	ND
Population Affected	Worker	Worker	0-726
Propylene	Consequence Scenario One compressor rupture		
	60 sec Fatal Fire Ball Radius	60 sec 2° Burns Radius	60 sec Pain Radius
Distance	11	11	17
Population Affected	Worker	Worker	Worker

4.15.3.2 CO₂ Pipeline

As described in Section 2.3.2.2, the proposed pipeline route would travel north beginning at the LCCE Gasification plant using an existing utility ROW, cross Bayou D’Inde Road and Bayou D’Inde, and continue north in an existing utility ROW running parallel to Bayou D’Inde Pass Road. The pipeline would cross underneath several roadways, Interstate 10, and U.S. Hwy 90 and terminate at an interconnect with the existing Green Pipeline (CH2M Hill 2011a).

The supercritical CO₂ transported in the pipeline is expected to meet the pipeline specifications summarized in Table 4.15-10. One of the major concerns regarding pipeline safety is the presence of water and other contaminants that can cause corrosion leading to pipeline failure (DOE 2007). When mixed with water, CO₂ can form carbonic acid, which is highly corrosive. For this reason, the moisture content of the CO₂ would be maintained at a low level. Leucadia would dry the CO₂ prior to compression, which reduces the risk of pipeline failure. CO₂ is a colorless, odorless, gas that is heavier than air; it is not reactive or flammable under typical environmental conditions. Table 4.15-2 describes health impact information for CO₂. The pressure drop from CO₂ leaks from process vessels (including pipes) creates a cold hazard, and even the vapor can cause frostbite (IPCC 2005). Due to the differences in concentration, pooling in confined spaces and under specific meteorological conditions and large, rapid releases of CO₂, rather than small gradual leaks, are generally the situations of concern for human health and safety (IPCC 2005; DOE 2007). Because the CO₂ specifications require less than 20 PPM of H₂S, it would not exceed the IDLH of 100 parts per million (see Table 4.15-2), therefore, the H₂S was not considered during the modeling of a CO₂ pipeline release scenario.

Table 4.15-10 Lake Charles CCS CO₂ Pipeline Specifications

≥ 97% CO ₂
<20 PPM H ₂ S
< 30 lbs./1,000 MCF Water Vapor
< 35 PPM Total Sulphur
< 2 PPB Mercury
<0.5% Inert Gases (including N ₂ and Argon)

As described above, a release from the pipeline represents the most probable scenario for a large volume release (DOE 2012). Operating experience records for hazardous liquid and carbon dioxide pipelines have been maintained for more than 60 years. Table 4.15-11 shows the number of safety incidents between 1992 and 2011 involving natural gas, hazardous liquid, and CO₂ pipelines. The annual incident frequency for CO₂ pipelines is 0.06 incidents per 100 miles of pipeline per year. The probability of a release for an 11.9 mile pipeline would be 7.3×10^{-3} . A CO₂ release from pipeline rupture or a release due to a pipeline puncture would be an unlikely event, which is estimated to occur between once in 100 years and once in 10,000 years of facility operations (frequency from 1×10^{-2} /year to 1×10^{-4} /year) (DOE 2012).

Table 4.15-11 CO₂ Pipeline , Hazardous Liquids, and Natural Gas Pipeline Incident Rate (1992 to 2011)

Category	CO ₂	Hazardous Liquids	Natural Gas
Miles of Pipeline	4,560	179,042	312,290
All Incidents	57	5,379	1,702
Property Damage (in \$M)	1.91	2,707.5	1,505.5
Fatalities	0	41	43
Injuries	1	170	221
Incidents per 100 miles per year	0.062	0.15	0.027

(2012 DOE)

As noted in Section 4.14, federal regulations apply to pipeline facilities and the transportation of hazardous liquids or carbon dioxide associated with those facilities in or affecting interstate or foreign commerce (49 CFR195.1) These regulations require development of a written integrity management program that addresses the risks on each segment of pipeline, including any pipeline located in a high consequence area (HCA) unless the operator effectively demonstrates by risk assessment that the pipeline could not affect the area. Pursuant to this DOT requirement and applying current industry practices, Denbury conducted a risk analysis for the proposed CO₂ pipeline. Details and results of Denbury’s risk analysis are provided in Appendix G and are summarized below.

Denbury’s risk assessment methodology was based on requirements of 49 CFR 195.452 for Pipeline Integrity Management. Denbury evaluated qualitative and quantitative estimates of CO₂ releases under different failure scenarios. Estimated concentrations of CO₂ in air were then used to estimate the potential for impacts on HCAs.

For the purposes of the dispersion modeling, Denbury selected the worst-case release scenario a full pipeline break or guillotine rupture. A guillotine rupture is a release from two pipe ends,

each with a cross-sectional area equal to the cross-sectional area of the pipe. Denbury’s analysis considered a 15 minute CO₂ maximum plume release period based on the time to achieve CO₂ flow through before valve shutdown.

Denbury’s analysis used CO₂ exposure limit concentrations levels established by OSHA, ACGIH, and NIOSH (see Table 4.15-2). Based on similarities in the severity and persistence of effects, these occupational limit concentrations may be considered comparable to AEGL levels for the general population as follows:

- AEGL 1: Permissible Exposure Limit (PEL): 5,000 ppm and Threshold Limit Value (TLV): 5,000 ppm
- AEGL 2: Short Term Exposure Limit (STEL): 30,000 ppm
- AEGL 3: Immediately Dangerous to Life or Health (IDLH): 40,000 ppm

Both the PEL and TLV specify airborne CO₂ concentration levels under which nearly all workers may be repeatedly exposed without potential adverse effects. The STEL represents the concentration to which workers can be exposed continuously for a short period of time without suffering from irritation, chronic or irreversible tissue damage, or narcosis of sufficient degree to increase the likelihood of accidental injury, impaired judgment, or material reduction in work efficiency.

Denbury contracted with American Innovations (AI) to perform the CO₂ dispersion modeling to assess the maximum potential consequence from the pipeline release scenario using the Det Norske Veritas PHAST model. As shown in Table 4.15-12, Denbury evaluated various dispersion distances along five pipeline sections for the two ambient temperature and wind conditions. These line breaks were selected to determine the worst case release scenario and the worst case dispersion distances. Given that the length of the pipeline is 11.9 miles, at the 6 mile distance break (50% of pipeline) the largest volume of CO₂ would be released from both sides of the rupture site. At the rupture site, the CO₂ would decompress from approximately 2,300 psi to a much lower pressure within about 50 to 60 seconds, but would continue to flow from the source until stopped.

Table 4.15-12 Pipeline Segment Exposure Distance Summary

Pipeline Mile Marker - Break Point	High Temperature/ Average Wind (40,000 ppm CO ₂ Exposure Distance in feet)	Low Temperature / Average Wind (40,000 ppm CO ₂ Exposure Distance in feet)	Census Block- Population Affected
0	781	750	0-51
3	872	836	0-51
6	925	886	52-181
9	837	802	52-701
11.8	735	707	0-181

The PHAST modeling results indicate that the largest extent of the CO₂ concentration of 40,000 ppm (AEGL 3) occurs within about 6 seconds. As the flow rate to the rupture site decreases, the

extent of CO₂ concentrations also decreases. PHAST modeling results indicate AEGL 3 levels occur at 925 feet from the pipeline under the high ambient temperature and annual average wind conditions. Under low temperature and annual average wind condition, the maximum AEGL 3 dispersion distance occurs up to 886 feet. These dispersion distances apply equally to both sides of the pipeline.

As a practice, Denbury uses the maximum distance for the ambient temperature and wind speed scenarios analyzed to establish a possible exposure footprint for the entire length of the pipeline lateral to determine whether the footprint included HCAs. This footprint represents the area where workers and the public could potentially be exposed to CO₂ AEGL 3 concentrations. The immediate area surrounding the pipeline ROW is mainly composed of industrial facilities, agriculturally developed lands, and to a lesser extent population centers. As shown in Figure 4.15-1, population densities range from 0 to 701 in the 925 foot area of the AEGL 3 concentrations.

The CO₂ pipeline would be directionally drilled under Bayou d'Inde and the Houston River. Although there is very little likelihood that CO₂ would be released into the water body, a general evaluation of the effects to ecological receptors was considered. If CO₂ travels vertically into the bottom of the water body, this could reduce water temperatures at the point of contact. If there is sufficient pressure it could also disrupt sediment resulting in entrainment of fine-grained particles into the water column. The introduction of CO₂ into the water body could also result in temperature reductions of up to 35°F and reduced pH conditions near the point of discharge. The saline nature of water in Bayou d'Inde would act to buffer any pH reduction, and water movement would quickly dissipate temperature, turbidity and pH changes. Minor disruption of benthic habitat and assemblages would occur, but these would be localized and insignificant. Overall, based on these findings, no effects to ecological receptors would be expected for a release of CO₂ from a pipeline rupture under a water body.

As described in Sections 4.13 and 4.14 and in Appendix G, Denbury would incorporate operational measures to prevent and control potential accidental CO₂ releases.

4.15.4 Intentional Destructive Acts

As with any U. S. energy and industrial infrastructure, the proposed project could potentially be the target of terrorist attacks or sabotage. DOE considered the potential environmental impacts from acts of terrorism or sabotage against the project facilities based on the analyses done for accidents. Although the likelihood of sabotage or terrorism cannot be quantified, because the probability of an attack is not known, the potential environmental effects of an attack would likely be similar to the effects described in this document for various accident scenarios. The accident analyses evaluated the outcome of various events without regard to determining the initiating cause or motivation behind the incident. Thus, such outcomes could be representative of the impacts of sabotage or terrorism. For example, potentially harmful chemicals could be released as a result of component failure or human error (or a combination of both), or from such intentional acts as intentional aircraft crashes, intentional truck crashes, arson fires, intentionally released valves and other acts of sabotage or terrorism.

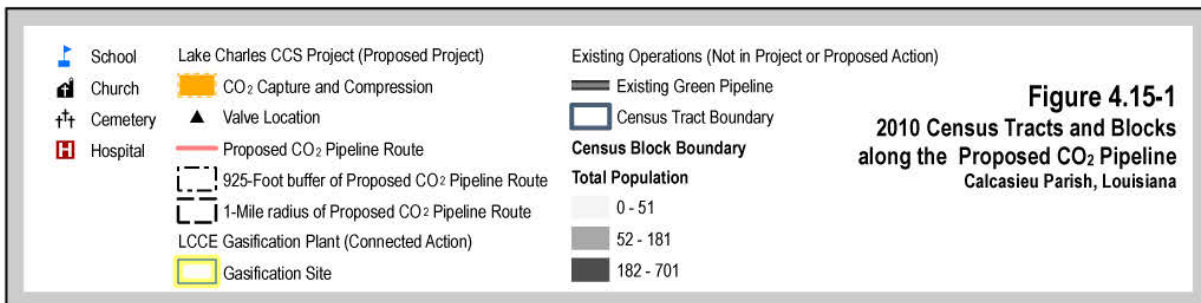
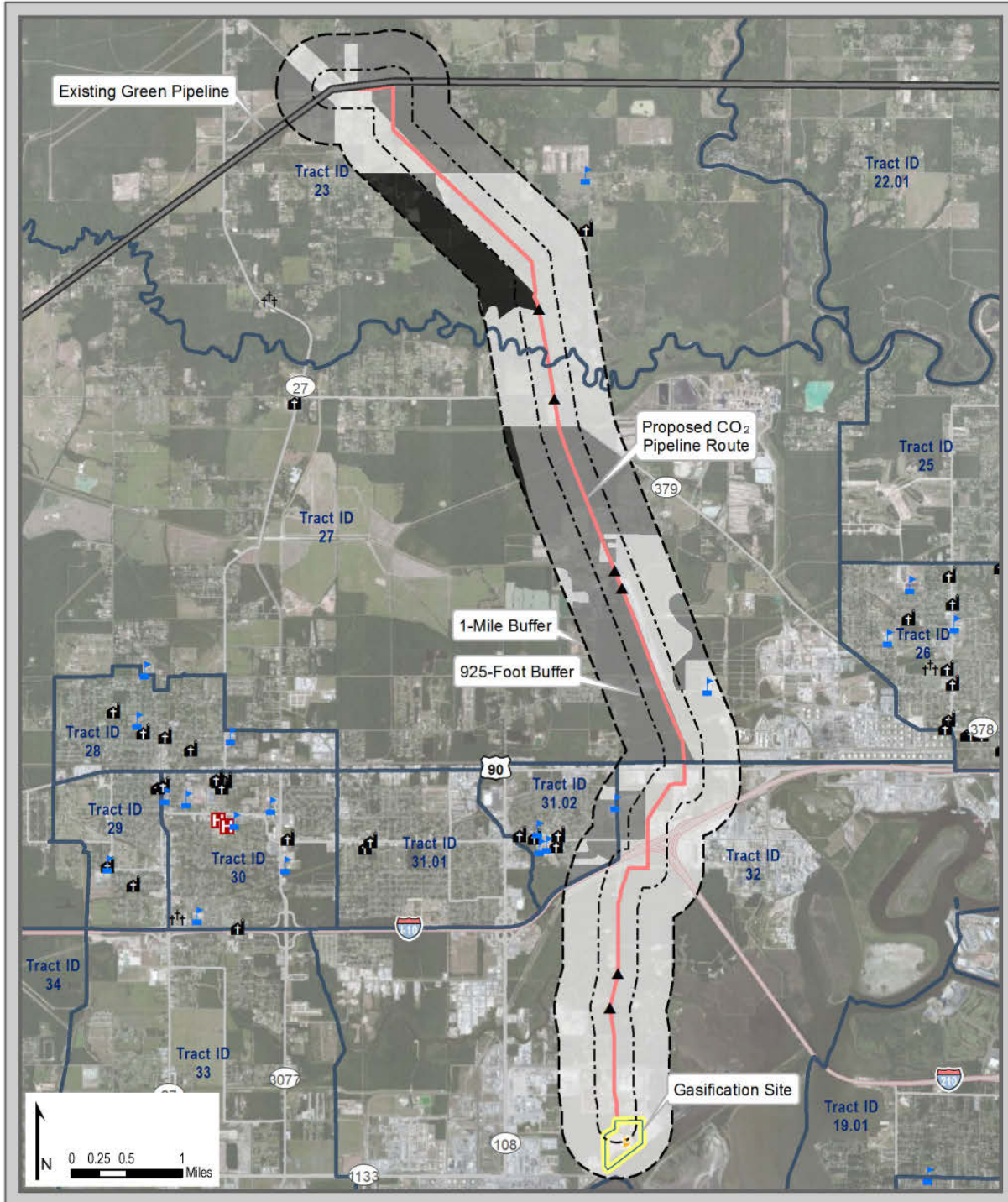

Figure 4.15-1
2010 Census Tracts and Blocks
along the Proposed CO₂ Pipeline
Calcasieu Parish, Louisiana

Service Layer Credits: © Harris Corp., Earthstar Geographics LLC
 © 2013 Microsoft Corporation

This page left blank intentionally.

Potential release scenarios of hazardous chemicals and consequences presented above for the LCCE Gasification plant and Lake Charles CCS project are considered to be representative of those that could be caused by intentional destructive acts. However, the frequency or likelihood of such events due to intentional destructive acts cannot be quantified.

4.16 Impacts of No Action

Under the no action alternative, DOE would not provide funding to Leucadia. In the absence of financial assistance from DOE, Leucadia could reasonably pursue several options. Leucadia could build both the LCCE Gasification plant and the Lake Charles CCS project with funding from other sources. DOE assumes that if Leucadia builds the LCCE Gasification plant and Lake Charles CCS project in the absence of DOE cost-shared funding, the plant would include the same features, attributes, and impacts described for the proposed project and connected action. Alternatively, Leucadia could choose not to build all or a portion of the LCCE Gasification plant and Lake Charles CCS project. For the purpose of making a meaningful comparison between the impacts of DOE providing and withholding financial assistance, DOE assumed that all or part of the LCCE Gasification plant and Lake Charles CCS project would not be completed without DOE funds. Therefore, the following sub-alternatives were identified and analyzed in the EIS:

1. No Action Sub-Alternative 1: Neither the LCCE Gasification plant nor the Lake Charles CCS project would be built, or
2. No Action Sub-Alternative 2: The LCCE Gasification plant would be built, but the captured CO₂ would be vented to the atmosphere and not sequestered in an ongoing EOR operation. Table 4.16-1 summarizes a comparison of the impacts from the proposed project and the two no action sub-alternatives.

4.16.1 No Action Sub-Alternative 1

Under no action sub-alternative 1, Leucadia would not build either the LCCE Gasification plant or the Lake Charles CCS project. The resources necessary for construction would be available for construction of other industrial projects on this site or elsewhere. The Port of Lake Charles would continue to ship petcoke worldwide for use as fuel in power plants. The use of petcoke in conventional power plants would likely emit more air emissions than use of petcoke in the LCCE Gasification plant because of the stringent emission control design and requirements in the latter compared to power production. Leucadia would not use the petcoke to produce a regional supply of hydrogen and methanol.

Environmental conditions would not change from the current baseline described in Chapter 3. The impacts on each of the resource areas would not occur, as summarized in Table 4.16-1. The local community would not experience the temporary minor impacts from noise, traffic, air emissions, or disruption to land use, nor would the benefits of jobs and economic development occur. Local merchants and suppliers would not see the economic benefits described above, nor would local government entities realize increases in *ad valorem* property taxes and sales tax revenues. The impacts on the environment from air emissions, disruption of wildlife, use of surface water, discharge of wastewater, and loss of wetlands would not occur. Denbury would continue to inject CO₂ from naturally occurring sources. The Lake Charles CCS project would not jointly fund the research MVA program performed at the West Hastings oil field.

No action sub-alternative 1 would not contribute to DOE's goal to advance the ICCS program by selecting projects to demonstrate the next generation of technologies that capture CO₂ emissions from industrial sources and either sequester them or beneficially reuse them.

4.16.2 No Action Sub-Alternative 2

Under no action sub-alternative 2, Leucadia would build the LCCE Gasification plant and vent the CO₂ to the atmosphere. The impacts from the construction and operation of the LCCE Gasification plant as described for each resource area would still occur, as summarized in Table 4.16-1. Leucadia would still capture the CO₂ from the syngas using Rectisol® as described. The CO₂ would not be compressed to a supercritical state, transported via the new 11.9 mile connector pipeline, or sequestered in commercial EOR activities. Leucadia would route the CO₂ stream to discharge to the atmosphere under the current air permit issued by LDEQ. Approximately 5.2 million tons of CO₂ would be emitted per year. Emissions produced from the construction of the pipeline and from indirect emissions associated with electricity use by the CO₂ capture and compression facility would not occur. Denbury would not construct the CO₂ pipeline, and environmental conditions would not change from the current baseline along the proposed pipeline route. No impacts related to construction of the CO₂ pipeline would occur. Fewer construction workers and operations personnel would be employed, and expenditures for construction, operation and maintenance would be reduced. The approximately 250 workers at peak construction would not be required. Under no action sub-alternative 2, the total socioeconomic impacts of this alternative would be similar to but less than those described under the proposed action. Denbury would continue to inject CO₂ derived from naturally occurring sources. The Lake Charles CCS project would not jointly fund the research MVA program performed at the West Hastings oil field.

If the Lake Charles CCS project is not built, the opportunity to capture 4.6 million tons of anthropogenic CO₂ from the LCCE Gasification plant for use in EOR would be lost. No action sub-alternative 2 would not contribute to DOE's ICCS program goal of demonstrating the next generation of technologies that capture CO₂ emissions from industrial sources and either sequester them or beneficially reuse them.

Table 4.16-1 Comparison of No Action Alternatives with Environmental Impacts of the Proposed Project and Connected Action

Resource Area	No-Action Sub-Alternative 1 (No build)	No-Action Sub-Alternative 2 (CO ₂ vented to atmosphere)	Lake Charles CCS Project (Proposed Project)	LCCE Gasification (Connected Action)
Climate and Air Quality	No new sources of air emissions. The petcoke would otherwise be used worldwide as fuel in power plants, and would likely emit more air emissions than LCCE Gasification.	Additional CO ₂ emissions of approximately 4.6 million tons per year would be emitted. Other minor emissions from pipeline construction would not occur. Impacts from LCCE Gasification would occur.	Construction: Negligible Vehicle and dust emissions associated with the CO ₂ pipeline construction would be temporary and have negligible impacts on air quality. The CO ₂ pipeline would be underground throughout its length, and no stationary point emission source. Operation: Negligible Fugitive dust and vehicle emissions would have temporary, negligible impacts on air quality at the West Hastings research MVA.	Construction: Negligible Vehicle and dust emissions would be temporary and would not affect maintaining attainment with the ozone standard. Operation: Negligible For all criteria pollutants, maximum modeled concentrations would not cause or contribute to any violation of the ambient air quality standards. The transport of petroleum coke would result in a reduction in emissions during shipment of 0.5 million tons per year of petroleum coke diverted from longer transport routes. Emissions would result in a temporary, negligible impact on air quality.
Geology and Soils	No change in existing conditions. Natural CO ₂ deposits would continue to be used for EOR. Use of 4.6 million tons of anthropogenic CO ₂ in EOR would not occur.	No disturbance of prime farmland. Natural CO ₂ deposits would continue to be used for EOR. Use of 4.6 million tons of anthropogenic CO ₂ in EOR would not occur. Impacts from LCCE Gasification would occur.	Construction: Minor Soil disturbance and stockpiling could be subject to erosion from both wind and water. Approximately 107 acres of prime farmland would be temporarily affected. Operation: Minor Approximately 4.6 million tons of CO ₂ would be sequestered in a portion of the West Hastings oil field. Soil disturbance and stockpiling could be subject to erosion from both wind and water. Approximately 107 acres of prime farmland would be temporarily affected.	Construction: Negligible Soil disturbance and stockpiling could be subject to erosion from both wind and water. Approximately 32 acres and 79 acres of prime farmland would be temporarily affected by the water supply and hydrogen pipeline construction, respectively. Construction would proceed in accordance with required federal and state permits and use of BMPs and would cause no or negligible impacts on soil. Areas not covered by impermeable surfaces would be landscaped and maintained. Pathways would be constructed to discourage foot traffic on unpaved areas, thereby protecting the remaining vegetation from disturbance and the soils from erosion. Operation: Minor Minor spills or leaks from vehicles and material storage areas could impact soils.

Table 4.16-1 Comparison of No Action Alternatives with Environmental Impacts of the Proposed Project and Connected Action

Resource Area	No-Action Sub-Alternative 1 (No build)	No-Action Sub-Alternative 2 (CO ₂ vented to atmosphere)	Lake Charles CCS Project (Proposed Project)	LCCE Gasification (Connected Action)
Surface Water, Floodplains, and Wetlands	No change in existing conditions. Surface water, floodplains, and wetlands would remain in their current status.	Waterbody crossings, floodplain wetland, and surface water impacts would not occur from the CO ₂ pipeline construction. Impacts from LCCE Gasification would occur.	<p>Construction: Minor The CO₂ pipeline would cross two major waterbodies using HDD construction methods; permanently impact 0.91 acres and temporarily impact 1.96 acres of wetland and permanently impact 14.98 acres and temporarily impact 13.23 acres of 100-year floodplain.</p> <p>Approximately 550,100 gallons of water for hydrostatic testing of the pipeline would be obtained from local water bodies or purchased from municipal supplies.</p> <p>Operation: Negligible Periodic maintenance and vehicle traffic would occur for research MVA.</p>	<p>Construction: Minor Construction may introduce contaminants to storm water runoff through excavation, material delivery and storage, concrete washout, waste generation, and equipment and vehicle use and storage. Wetland impacts were addressed through off-site mitigation banking of 26.2 acres of the wetlands through an agreement between the Port of Lake Charles and Stream Wetland Services, LLC. Water required for construction of the parking area would include one water truck supplying an average of 2,000 gallons per day for 3 years. Additional floodplain and wetland impacts may occur at the 40 acre site of the equipment laydown area and methanol/sulfuric acid storage area, depending on the final location selected.</p> <p>The water supply pipeline would cross Bayou d’Inde and Bayou Verdine and impact 3.55 acres of wetlands. The hydrogen pipeline would cross Bayou d’Inde, the Sabine River Canal, and two additional waterbodies using HDD construction methods and impact 3.59 acres of wetlands. Hydrostatic testing of the water supply and hydrogen pipelines would require approximately 193,600 and 412,890 gallons, respectively.</p> <p>Operation: Negligible Operation would use an annual average maximum of 8,500 GPM, or 12.2 million gallons per day of raw water from Sabine River. Wastewater, including cooling tower blowdown, water treatment reject, and plant drains and would be discharged as directed by the LDEQ LPDES Water Discharge Permit LA0124541 and AI No. 160213.</p>
Groundwater	No change in existing conditions.	HDD crossings of waterbodies in CO ₂ pipeline corridor would not occur. Impacts from LCCE Gasification would occur.	<p>Construction: Negligible HDD would intersect the shallow unconfined aquifer; however the recharge area of the shallow sand aquifer is the 2-million-plus acre infiltration area of the Calcasieu River basin.</p> <p>Operation: Negligible Small, incidental drips and leaks of fuels or lubricants could occur during maintenance.</p>	<p>Construction: Negligible There would be no onsite discharge to groundwater or use of groundwater. HDD would intersect the shallow unconfined aquifer; however the recharge area of the shallow sand aquifer is the 2-million-plus acre infiltration area of the Calcasieu River basin.</p> <p>Operation: Negligible Small, incidental spills of fuels or lubricants could occur during maintenance and would be managed in accordance with Leucadia’s SPCC Plan.</p>

Table 4.16-1 Comparison of No Action Alternatives with Environmental Impacts of the Proposed Project and Connected Action

Resource Area	No-Action Sub-Alternative 1 (No build)	No-Action Sub-Alternative 2 (CO ₂ vented to atmosphere)	Lake Charles CCS Project (Proposed Project)	LCCE Gasification (Connected Action)
Biology	No change in existing conditions. Vegetation, aquatic ecology, and wildlife resources would remain in current conditions.	CO ₂ pipeline impacts would not occur, including loss of vegetation and potential impacts to habitat for red-cockaded woodpecker and colonial water birds. Impacts from LCCE Gasification would occur.	Construction: Minor Pipeline construction would affect 10.21 acres of forest, 17.65 acres of scrub-shrub, and 2.1 acres of herbaceous grassland habitats. No federally or state-protected species or habitat were identified in biological surveys, including suitable habitat for colonial wading birds. Denbury would survey suitable nesting areas no more than two weeks before construction begins to determine whether breeding colonies are present. Operation: Negligible Long-term maintenance of the CO ₂ pipeline, if it occurs during the breeding season, could cause noise and dislocation of colonial wading birds and species in adjacent forested habitats if determined to be present. Resident terrestrial species have the ability to relocate.	Construction: Minor Clearing of the equipment laydown area would remove 40 acres of potential forested habitat. The water supply and hydrogen pipeline corridors would impact 18.47 and 62.74 acres, respectively, of forest habitat potentially used by the red-cockaded woodpecker. Suitable habitat for colonial wading birds may be present along the pipeline route intersections with Bayou D'Inde and around the Houston River. Operation: Negligible Long-term maintenance of the hydrogen pipeline, if it occurs during the breeding season, could cause noise and dislocation of colonial wading birds and species in adjacent forested habitats if determined to be present. Resident terrestrial species have the ability to relocate.
Cultural Resources	All potentially impacted resources would remain in place.	No drilling beneath the Hardey cemetery for the CO ₂ pipeline installation would occur. Impacts from LCCE Gasification would occur.	Construction: Minor Directional drilling beneath the cemetery, at a minimum depth of 25 feet below the surface of the Hardey cemetery. Cemetery owners have indicated no objection. The presence of the buried pipeline may alter the setting of the cemetery. Destruction of the portion of archaeological site 16CU73 that is within the ROW. Operation: Minor The presence of the buried pipeline may alter the setting of the cemetery.	Construction: Minor Destruction of the portion of archaeological site 16CU29 that is within the APE during ground disturbance associated with site preparation. Operation: None
Land Use	No changes in area land use. Sites and linear facility corridors would remain in current uses.	Conversion of land to ROW would not occur if the CO ₂ pipeline is not constructed. Disturbances to landowners would not occur. Impacts from LCCE Gasification would occur.	Construction: Negligible Construction would cause short term impacts to 50.62 acres of temporary ROW which would be restored to previous conditions and uses. 56.34 acres would be impacted long-term, including 8.27 acres of forested land with 2.98 acres of forested wetland. No special land uses would be impacted by construction activities. Operation: Negligible Operation of the CO ₂ pipeline would require that the area remain clear of woody vegetation and development. Where the pipeline ROW crosses	Construction: Minor The area is zoned heavy industrial. The gasification plant would impact 70 acres of industrial property. Construction of the raw water pipeline would impact a total of 122 acres of land, including 24 acres of permanent ROW and 98 acres of temporary ROW. Construction of the hydrogen pipeline (excluding additional temporary workspace and contractor work sites not within the ROW) would impact a total of 77 acres of land, including 51 acres of permanent ROW and approximately 26 acres of temporary ROW. Surrounding residents and businesses may experience temporary

Table 4.16-1 Comparison of No Action Alternatives with Environmental Impacts of the Proposed Project and Connected Action

Resource Area	No-Action Sub-Alternative 1 (No build)	No-Action Sub-Alternative 2 (CO ₂ vented to atmosphere)	Lake Charles CCS Project (Proposed Project)	LCCE Gasification (Connected Action)
			private property, operation of the CO ₂ pipeline would require that landowners not construct or place any structures (including houses, tool sheds, garages, guy wires, catch basins, swimming pools, trailers, leach fields, septic tanks, or any other objects not easily removable) within the permanent pipeline ROW. Occasional maintenance may require access to buried portions of the pipeline.	traffic congestion and increased noise and dust levels. Operation: Negligible Occasional maintenance may require access to buried portions of the water supply and hydrogen pipelines.
Socioeconomics and Environmental Justice	Leucadia would not use the petcoke to produce a regional supply of hydrogen and methanol. No potential for economic stimulus from proposed project. No change in employment, housing or community services.	Approximately 100 average and 250 peak construction jobs would not occur. Jobs created from LCCE Gasification would occur.	Construction: Minor Construction would require an average of approximately 100 workers, with the total number of construction workers reaching 250 at peak. Demand for temporary housing such as hotel/motel rooms, RV sites, and other rental properties would increase providing a benefit to local providers. The area as a whole is not considered an environmental justice area; however certain census tracts have significantly higher proportions of minority and/or Hispanic populations and populations below the poverty level. Operational workers would be hired locally and would, therefore, not impact the total population in the Greater Lake Charles area. Operation: Negligible The West Hastings research MVA would create 14 jobs with 4 month duration; and 7 operations jobs, with up to 4 years duration. The program could have the positive impact of helping to ensure the long-term economic and financial viability of CO ₂ capture activities by confirming storage of CO ₂ injected in EOR operations. Census tracts in the area have a significantly larger proportion of minority and/or Hispanic population than Brazoria County or Texas.	Construction: Minor Construction would temporarily increase employment in the region during the 36-month construction period and would require a peak of 900 workers on site and 2500 in the surrounding area. The increase in demand for temporary housing would temporarily reduce vacancy rates for such properties throughout the region and would provide short-term economic benefits to owners of temporary housing in the region. The area around the site is not considered an environmental justice area. Operation: Minor Operation would require 187 new permanent workers and approximately 90% of these additional workers would be hired from the existing local labor market 19 permanent workers would relocate to the area.

Table 4.16-1 Comparison of No Action Alternatives with Environmental Impacts of the Proposed Project and Connected Action

Resource Area	No-Action Sub-Alternative 1 (No build)	No-Action Sub-Alternative 2 (CO ₂ vented to atmosphere)	Lake Charles CCS Project (Proposed Project)	LCCE Gasification (Connected Action)
Traffic and Transportation	No change in existing traffic. Level of service (LOS) conditions would remain the same.	The increase in traffic during pipeline construction and would not occur. Traffic impacts from LCCE Gasification would occur.	Construction: Minor Approximately 100 personnel and up to 10 trucks would access the pipeline ROW daily during 3 to 4 months construction. Construction would allow for traffic flow across the open area except for the limited periods required for actual pipeline installation. Operation: Negligible Periodic maintenance of the ROW would include mowing and occasional maintenance activities that may require access to buried portions of the utilities. Approximately 14 additional personnel would access the West Hastings research MVA area.	Construction: Minor Approximately 500 workers would access the construction parking area at the beginning and end of each shift using State Highway 108. Leucadia would obtain a temporary construction access permit from DOTD, if required. Approximately 150 off-site construction vehicles would deliver materials daily during peak construction. Use of Ruth Street during peak construction would degrade LOS from E to F. Operation: Negligible Approximately 187 personnel would access the site during operation. Approximately 81 one-way truck trips would be access the site daily to remove waste materials or deliver materials.
Noise	No new sources of noise would be built and operated. The existing sound environment would remain.	HDD drilling noise and related pipeline construction noise would not occur. Noise impacts from LCCE Gasification would occur, including the water supply and hydrogen pipelines.	Construction: Minor Noise levels may exceed the EPA guideline level of 55 dBA L _{dn} at some residences during CO ₂ pipeline construction. HDD activities in the evening or weekends within 165 feet of a residence or noise sensitive area of the pipeline may require a variance from local ordinances. Operation: Negligible Noise would be generated from equipment and vehicles used during pipeline inspection and maintenance activities. At the West Hastings research MVA, operation of workover rig and supporting equipment would imperceptible.	Construction: Minor Noise generating equipment includes various trucks and pile driving on the gasification site. Existing background level of 53 dBA exceeds the EPA guideline and noise during construction would increase imperceptibly. A variance may be required to conduct HDD activities in the evening or weekends within 165 feet of a residence or noise sensitive area of the water supply pipeline may require a variance from local ordinances. Noise impacts on the hydrogen pipeline corridor may exceed HUD guidelines. Operation: Negligible Leucadia equipment estimated sound level at nearest noise receptor would exceed the EPA L _{dn} of 55 dBA but would not exceed the ambient background L _{eq} of 60 dBA.
Wastes	No added health and safety risks. No increases in the construction or operational health and safety risks. No probability of an accidental release of hazardous materials.	Similar impacts to LCCE Gasification, however slightly less quantities of wastes would be produced since the CO ₂ compression facilities and pipeline would not be built.	Construction: Negligible Construction waste from the CO ₂ pipeline would primarily consist of land clearing debris and drilling muds from HDD, construction mats and scrap, packaging materials, and general refuse. Operation: Negligible During operation, waste generation would be limited to periodic ROW maintenance activities including mowing of ground cover, clearing of vegetation, maintenance of access and service roads, and servicing and monitoring of pipeline system components.	Construction: Negligible Construction would generate minor quantities of solid, nonhazardous waste streams, including construction debris, vegetation from site clearing, general office trash, and surplus construction materials such as timber, concrete, gravel, metals, plastics, and empty containers. Potentially hazardous wastes that could be generated during construction include small quantities of waste paints, varnish, solvents, sealers, thinners, resins, roofing cement, adhesives, lubricants, and used oil.

Table 4.16-1 Comparison of No Action Alternatives with Environmental Impacts of the Proposed Project and Connected Action

Resource Area	No-Action Sub-Alternative 1 (No build)	No-Action Sub-Alternative 2 (CO ₂ vented to atmosphere)	Lake Charles CCS Project (Proposed Project)	LCCE Gasification (Connected Action)
				<p>Operation: Negligible During operation, the primary solid waste stream generated during operation is nonhazardous slag. Catalysts, adsorbents, and ZLD solids may have hazardous characteristics and would be tested to determine the proper disposal requirements. The disposal of nonhazardous and potentially hazardous wastes would not exceed the capacity or management of hazardous or solid waste services and landfills in the area.</p>
Materials	<p>No change in existing conditions. No increase in the use of construction materials and no impact of hazardous material release.</p>	<p>Similar impacts to LCCE Gasification, however smaller quantities of materials would be used since the CO₂ compression facilities and pipeline would not be built.</p>	<p>Construction: Minor Construction of the CO₂ pipeline would require carbon steel pipe, valves pumps, fittings, process materials, and cathodic protection equipment, controls, and monitoring systems, fuel, lubricants, transmission fluids, oils) necessary for the operation and maintenance of equipment and vehicles. Operation: Negligible Supercritical CO₂ would be transported via the pipeline. Maintenance would typically require ground-cover mowing, vegetation clearing, maintenance of access and service roads maintenance, and servicing and monitoring of pipeline system components. For the research MVA program, materials used include fuels, oils, lubricants, corrosion inhibitors, ready-mix concrete, gravel fill, reinforcing steel, equipment rentals, piping, fittings, valves, and welding materials. Small amounts of materials and oil products may spill as a result of equipment failure (split hydraulic lines, broken fittings) or human error (overfilled tanks).</p>	<p>Construction: Minor Construction materials would consist of steel, concrete, wood, fuel, and steel, crushed stone, sand, lumber, ductwork, insulation, electrical cable, lighting fixtures, and transformers and hazardous substances including lubricants, transmission fluids, oils, etc. for the operation and maintenance of vehicles and construction equipment. Operation: Negligible Petcoke, fluxant, fuel, aqueous ammonia, and chlorine would be the primary materials used. Operation would use or produce industrial chemicals, including aqueous ammonia, methanol, sulfuric acid, hydrogen, and fuels. Small amounts of materials and oil products may spill as a result of equipment failure (split hydraulic lines, broken fittings) or human error (overfilled tanks).</p>

Table 4.16-1 Comparison of No Action Alternatives with Environmental Impacts of the Proposed Project and Connected Action

Resource Area	No-Action Sub-Alternative 1 (No build)	No-Action Sub-Alternative 2 (CO ₂ vented to atmosphere)	Lake Charles CCS Project (Proposed Project)	LCCE Gasification (Connected Action)
Human Health and Safety	No added health and safety risks. No increases in the construction or operational health and safety risks.	<p>No added health and safety risks from constructing the new 11.9 mile CO₂ pipeline connecting to the existing Green Pipeline.</p> <p>Use of 4.6 million tons of anthropogenic CO₂ in EOR would not occur.</p>	<p>Construction: Negligible Construction of the CO₂ capture and compression equipment would be included in the recordable incidents for LCCE Gasification. An estimated 1.08 OSHA-recordable cases and 0.6 cases with days away would be anticipated during the construction of the CO₂ pipeline based on national incidence rates and 250 employees during the peak construction period. Based on fatality rates for construction and extraction sector, the fatality rate would be below one (0.01) and no fatalities would be expected. It is not expected that the public would be on site or be exposed to chemical or industrial hazards or contaminants that would exceed public health standards.</p> <p>Operation: Negligible An estimated 1.5 OSHA-recordable cases and 1.2 cases with days away would be anticipated during a 30-year life of the pipeline, based on national incidence rates and the estimated three workers employed during operation of the pipeline.</p>	<p>Construction: Negligible An estimated 84 OSHA recordable cases and 46 cases with days away would be anticipated during construction based on national incidence rates and the estimated 900 construction workers employed on site during peak construction. The public would not have access to the construction area. Vehicle emissions would not expose sensitive receptors to substantial pollutant concentrations.</p> <p>Operation: Negligible An estimated 62 OSHA-recordable cases and 34 cases with days away would be anticipated during operation based on national incidence rates and the estimated 187 workers employed during the 30 year life of the plant. Based on fatality rates for petroleum refineries, the fatality rate would be below one (0.02) and no fatalities would be expected. Air emissions of criteria pollutants and toxic air pollutants do not cause or contribute to any violation of the NAAQS or Louisiana ambient air standards or expose sensitive receptors to substantial pollutant concentrations.</p>

This page left blank intentionally.

5. Potential Cumulative Effects

5.1 Approach and Analytical Perspective

5.1.1 Background

Compliance with NEPA requires an analysis of cumulative effects for each alternative (40 CFR 1508.25(c)(3)). Cumulative effects are the collective result of the incremental effects of an action that, when added to the impacts of other past, present, and reasonably foreseeable future actions, would affect the same resources, regardless of what agency or person undertakes those actions (40 CFR 1508.7). Cumulative effects can result from actions that have individually minor impacts but that collectively impose significant impacts over a period of time. DOE considers a reasonably foreseeable action to be a future action that has a realistic expectation of occurring. These include (but are not limited to) actions under analysis by a regulatory agency, proposals being considered by state or local planners, plans that have begun implementation, or future actions that have been funded.

Humans have been altering the area in which the Lake Charles CCS Plant would be constructed and operated since people began settling the region. In combination with natural processes, these past and present actions and activities have produced the affected environment, which is described in detail in Chapter 3. The impacts of the proposed project and connected action on the existing environment are described in Chapter 4.

In this chapter, DOE describes the potential for cumulative effects of the Lake Charles CCS project and reasonably foreseeable future actions. The following sections describe the process DOE used to identify potential cumulative effects issues. First, the evaluation identifies the geographic area of project impacts, the reasonably foreseeable future development actions, and trends occurring in the areas of analysis. Second, the analysis methodology considers the resource, ecosystem, or human community that could be affected cumulatively, and the issues that indicate the importance of a potentially cumulative impact. Finally, potential cumulative issues of high or intermediate importance were evaluated further.

5.1.2 Geographic Area of Project Impacts

Cumulative effects are analyzed on the basis of particular environmental resources or impact areas. Depending on the particular issue, this area of analysis either is a human community (e.g., the Louisiana area), an ecosystem (e.g., the southern Gulf Coast), or a resource as described on a regional, national, or global level (e.g., air quality within an Air Quality Control Region). Because information and statistics often are compiled by governmental agencies based on their areas of jurisdiction, these boundaries may be substituted as proxies for the more appropriate natural or socioeconomic boundaries.

Proposed projects, actions, or facilities within the general vicinity of the proposed project site or site of the connected actions may have impacts with the potential to combine with those of the Lake Charles CCS project to create cumulative impacts. The analysis for each resource area is restricted to geographic areas around where the resource could be impacted, by the time frame of the projects (short-term construction or longer-term operation), and by the presence of the resource at risk. For most resources, the area within a radius of 0.5 mile of the proposed project and connected actions would reasonably encompass any foreseeable cumulative impacts that could result. Transportation was considered to have a potentially minor impact during

construction only. The geographic boundary for transportation was assumed to encompass major roads that would be shared during the construction phases of this project and other projects.

For specific resource areas, a larger geographic scope was considered appropriate. For example, since air quality impacts can affect a regional area, the geographic area for the cumulative analysis considered the air quality control region and, more broadly, global impacts of CO₂ emissions. For impacts on geology, the analysis considered Brazoria County and the Gulf Coast. For biology, the analysis considered the Bayou D'Inde watershed and the downstream component of the Calcasieu River watershed to determine potential cumulative effects on forest and aquatic ecosystems. For surface water, specifically wetlands, the analysis considered downstream conditions in the Calcasieu River/Ship Channel, within the USGS and USACE hydrological unit code of the Lower Calcasieu Watershed (Hydrological Unit Code [HUC] 08080206).

5.1.3 Reasonably Foreseeable Future Development: Specific Actions and Trends

For this cumulative effects analysis, reasonably foreseeable future development was considered in the context of (1) specific proposals and (2) general trends in the region. The predicted environmental effects of specific proposals and general development trends were considered together with those of the proposed project or connected action to produce a description of the combined or cumulative environmental effects.

To identify specific proposals that might impose cumulative environmental effects in the region, DOE sought information on specific projects, developments, or activities with potential impacts that would overlap with those of the proposed project or connected action. This included a search for conventional electric power projects, large industrial facilities, transportation projects, large commercial developments, municipal projects, water supply projects, and other such projects in the region.

DOE identified potential projects by contacting regulatory and planning agencies. The potential projects were screened for review using a standard of 1) having submitted a site plan for review by a local planning agency or 2) an application submitted to a regulatory agency for permit review. These screening criteria also included projects announced by a government agency. In many cases the lack of detailed investigations that are available for future projects, actions, or facilities may require qualitative assessments of potential cumulative impacts. Evaluating the potential cumulative impacts of future projects and the current proposed project and connected action creates an unavoidable level of uncertainty. Projects can be delayed, abandoned, or altered between the time they are announced and the time they are completed or abandoned. This simple screening procedure has proven to be helpful in removing some of the uncertainty and qualitative judgement associated with identifying viable, reasonably foreseeable projects and providing some reasonable assurance that the cumulative impact analysis would yield realistic conclusions.

The reasonably foreseeable projects in the study area are identified on Figure 5.1-1 and described in Table 5.1-1. Except for the Lake Charles Harbor and Terminal District, which is adjacent to the project site and is undergoing concurrent renovations, the closest of the external projects, the Sasol gas-to-liquids plant in Westlake, is 3.75 miles from the site. All of these projects are located on industrial sites and can add cumulative impacts to those identified in Chapter 4 as part of the proposed project or connected action.

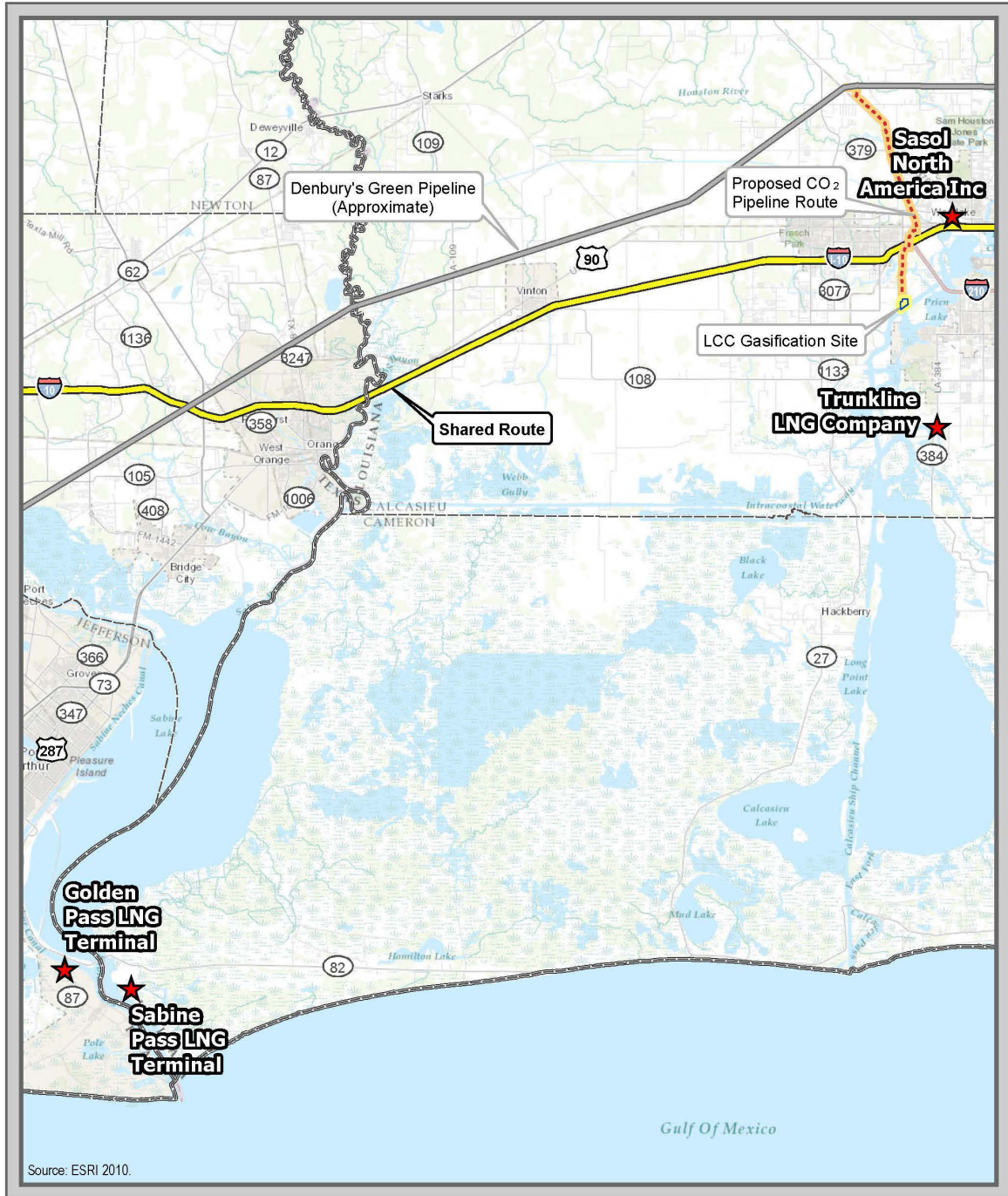

Source: ESRI 2010.

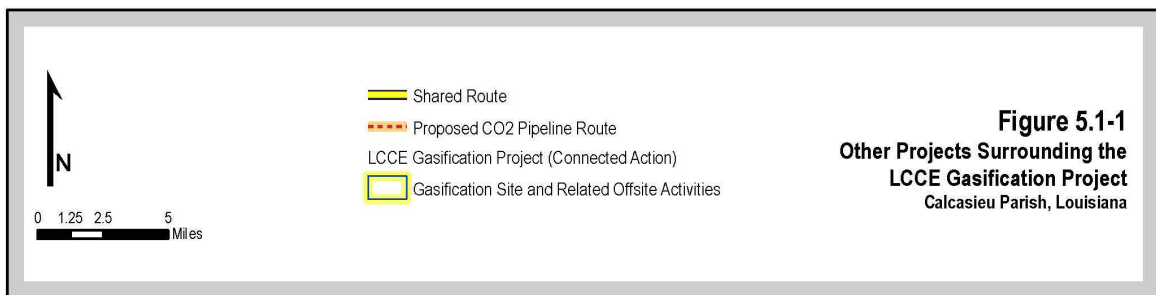

Figure 5.1-1
Other Projects Surrounding the
LCCE Gasification Project
 Calcasieu Parish, Louisiana

Service Layer Credits: Sources: Esri, DeLorme, NAVTEQ, TomTom, Intermap, increment P Corp., GEBCO, USGS, FAO, NPS, NRCAN, GeoBase, IGN, Kadaster NL, Ordnance Survey, Esri Japan, METI, Esri China (Hong Kong), swisstopo, and the GIS User Community

This page left blank intentionally.

Regarding the analysis of trends, this analysis assumed a current trend would continue into the future unless there was reason to believe that the trend may change. Various organizations produce forecasts that can support the analysis of cumulative effects, and these were used where available and relevant.

5.1.4 Analysis Methodology

If the proposed project, connected action, or its alternative would result in a direct or indirect impact on a resource area, DOE considered further analysis of potential cumulative effects for that resource area. Table 5.1-2 summarizes the potential unavoidable impacts of the proposed project, connected action, and alternatives. Table 5.1-2 presents the results of the analysis of environmental consequences identified in Chapter 4 for all resource areas.

If a potential impact evaluated in Chapter 4 was determined to be negligible, no further evaluation of potential cumulative impacts was conducted. In these cases, the addition of the proposed project and connected action could result only in a negligible additional adverse impact in the worst case. The resource areas that were considered to have minor, moderate, or substantial potential unavoidable impacts include:

- Air Quality
- Global Climate Change
- Geology
- Soils
- Biology
- Surface Water, specifically wetlands impacted directly by construction
- Traffic and Transportation
- Socioeconomics

DOE assembled an internal team of environmental professionals to propose, list, and classify potential issues related to cumulative effects, based on the results of the public scoping process, the results of the environmental impacts analyses conducted for this EIS, and the assessment of potential environmental impacts of future development and trends in the region. The identified issues were then classified as potentially having a high, intermediate, or low level of importance. Indicators of importance are listed in Table 5.1-3.

For each issue, these specialists searched for relevant information on past and current activities and their environmental impacts in the resource area of concern to establish a basis upon which to consider potential impacts of the proposed project or connected action. Trends in past and current activities and their environmental impacts were projected into the future for at least the expected 30-year life of the project, to the extent that the projection was considered to be reasonable. Where usable forecasts were found, DOE evaluated whether the forecast already encompassed the proposed project or connection action. If not, the potential impacts were added to the impacts considered in the cumulative impact analysis.

Table 5.1-4 describes potential cumulative effects issues with a high or intermediate level of importance for the resource areas with minor direct or indirect impacts. No resources areas had moderate or substantial impacts. Sections 5.2 and 5.3 discuss resources areas with effects determined to have high and intermediate importance, respectively.

Table 5.1-1 Regional Projects Identified for Consideration in the Cumulative Impacts Analysis

Project (Owner)	Location	Distance from Site (miles)	Status	Description	Additional Information
Lake Charles Export LNG Terminal (Trunkline LNG)	Lake Charles, LA	5.3	Ongoing; FERC Pre-filing request submitted in March 2012	Trunkline LNG Company, a subsidiary of Southern Union Company, has filed a request with FERC to begin the pre-filing review process to build and operate a natural gas liquefaction project in Lake Charles, Louisiana. The project will take natural gas in its gaseous state and convert it into liquefied natural gas (LNG) for shipment to natural gas markets around the world.	http://www.panhandleenergy.com/lakeCharles/lc_regulatory.asp
Westlake Gas-to-Liquids Plant (Sasol)	Westlake, LA	3.75	Ongoing; feasibility study scheduled to be completed by March 2013	Sasol is conducting a study to evaluate the feasibility of constructing a gas-to-liquids (GTL) plant in Westlake, Louisiana, that would convert natural gas to diesel and jet fuel in a cost-efficient and environmentally friendly way.	http://www.sasolgtl.com/page.php?page=westlake_project
Sabine Pass LNG Export Terminal (Chenier Energy)	Cameron Parish, LA	46	Ongoing; FERC authorization issued on April 16, 2012	Cheniere Energy proposes to install liquefaction services at the Sabine Pass LNG receiving terminal in Cameron Parish, Louisiana. Adding liquefaction capabilities will transform the Sabine Pass terminal into a bi-directional facility capable of liquefying and exporting natural gas in addition to importing and regasifying foreign-sourced LNG. The Sabine Pass site can readily accommodate up to four LNG trains capable of processing approximately 2 billion cubic feet per day (Bcf/d) of natural gas.	http://www.cheniere.com/lng_industry/sabine_pass_liquefaction.shtml
Cameron LNG Export Terminal (Sempra Energy)	Cameron Parish, LA	47	Ongoing; FERC Pre-filing request submitted in April 2012	Cameron LNG is obtaining approval from DOE to export up to 12 million metric tons per year, or approximately 1.7 billions of cubic feet per day, of domestically produced liquefied natural gas (LNG) to all current and future Free Trade Agreement countries.	http://cameron.sempraeng.com/liquefaction.html

Table 5.1-1 Regional Projects Identified for Consideration in the Cumulative Impacts Analysis

Project (Owner)	Location	Distance from Site (miles)	Status	Description	Additional Information
Lake Charles Harbor and Terminal District	Calcasieu Parish, LA	0	Ongoing	The Port of Lake Charles is the 11 th largest seaport in the U.S. The principal cargoes moving through the port's terminals are bagged rice, flour, and other food products; forest products; aluminum; petroleum coke and other petroleum products; woodchips; barites; and rutile. The port identifies active development projects on its website.	http://www.portlc.com/AboutUs.asp
Hastings Oil Field	Brazoria County, TX	0	Ongoing	DOE awarded a financial assistance grant under the American Recovery and Reinvestment Act of 2009 in the form of a cooperative agreement with Air Products and Chemicals, Inc. (Air Products), as part of the Industrial Carbon Capture and Sequestration (ICCS) program. Air Products' proposed project involves an integrated carbon capture, transport, injection, sequestration, and monitoring program of approximately 1 million tons per year (tpy) of CO ₂ from Air Products' two H ₂ plants in Port Arthur, Texas, for use in CO ₂ EOR at the Hastings oil field.	
West Ranch Oil Field	East of Victoria in Jackson County, TX	100 miles SE	Ongoing	DOE selected NRG for a financial assistance award through a competitive process under the Clean Coal Power Initiative (CCPI) program to demonstrate CCS technologies at coal-fired power plants. NRG is authorized to design, construct, and operate a commercial-scale carbon dioxide (CO ₂) capture facility at its existing W.A. Parish Generating Station (Parish Plant) in Fort Bend County, Texas; deliver the CO ₂ via a new pipeline to the existing West Ranch oil field in Jackson County, Texas, for use in EOR operations; and demonstrate monitoring techniques to verify the permanence of geologic CO ₂ storage. The Draft EIS was issued by DOE.	http://www.netl.doe.gov/publications/others/nepa/deis_sept.html

Table 5.1-2 Summary of Unavoidable Environmental Impacts

Resource Area	Lake Charles CCS Project (Proposed Action)				LCCE Gasification (Connected Action)
	CO ₂ Capture and Compression	Proposed CO ₂ Pipeline Route	Alternative CO ₂ Pipeline Route	West Hastings Research MVA	Gasification Plant Site and Off-site Activities
Climate and Air Quality	<i>Included in LCCE Gasification</i>	<p>Construction: Negligible Fugitive dust and vehicle and construction equipment emissions would be temporary and have negligible impacts on air quality.</p> <p>Operation: Negligible Vehicle emissions would have temporary, negligible impacts on air quality.</p>	<p>Construction: Same as proposed route</p> <p>Operation: Same as proposed route</p>	<p>Construction: Not applicable</p> <p>Operation: Negligible Fugitive dust and vehicle emissions would have temporary, negligible impacts on air quality.</p>	<p>Construction: Negligible Fugitive dust and vehicle and construction equipment emissions would be temporary and would not affect maintaining attainment with the ozone standard.</p> <p>Operation: Negligible For all criteria pollutants, maximum modeled concentrations would not cause or contribute to any violation of the ambient air quality standards. The transport of petroleum coke would result in a reduction in emissions during shipment of 0.5 million tons per year of petroleum coke diverted.</p>
Geology and Soils	<i>Included in LCCE Gasification</i>	<p>Construction: Minor Soil disturbance and stockpiling could be subject to erosion from both wind and water. Approximately 107 acres of prime farmland would be temporarily affected.</p> <p>Operation: Negligible Any areas of soil exposed during construction of the CO₂ pipeline would be returned to their original condition and usage.</p>	<p>Construction: Same as proposed route</p> <p>Operation: Same as proposed route</p>	<p>Construction: Not applicable</p> <p>Operation: Minor Approximately 4.6 million tons of CO₂ would be sequestered in a portion of the West Hastings oil field.</p>	<p>Construction: Negligible Soil disturbance and stockpiling could be subject to erosion from both wind and water. Approximately 32 acres and 79 acres of prime farmland would be temporarily affected by the water supply and hydrogen pipeline construction, respectively.</p> <p>Operation: Minor Minor spills or leaks from vehicles and material storage areas could impact soils.</p>

Table 5.1-2 Summary of Unavoidable Environmental Impacts

Resource Area	Lake Charles CCS Project (Proposed Action)			West Hastings Research MVA	LCCE Gasification (Connected Action)
	CO ₂ Capture and Compression	Proposed CO ₂ Pipeline Route	Alternative CO ₂ Pipeline Route	Gasification Plant Site and Off-site Activities	
Surface Water, Floodplains, and Wetlands	<i>Included in LCCE Gasification</i>	<p>Construction: Minor The proposed CO₂ pipeline would cross Bayou D'Inde and the Houston River using HDD construction methods. Pipeline route would potentially permanently impact 9.98 acres and temporarily impact 9.02 acres of wetland and permanently impact 14.98 acres and temporarily impact 13.23 acres of 100-year floodplain. Approximately 550,100 gallons of water for hydrostatic testing of the pipeline would be obtained from local water bodies or purchased from municipal supplies.</p> <p>Operation: Negligible Periodic maintenance and vehicle traffic would occur.</p>	<p>Construction: Minor The alternative CO₂ pipeline would cross two major waterbodies; impact 26.3 acres of wetland and permanently impact 16.67 acres and temporarily impact 14.57 acres of 100-year floodplain.</p> <p>Operation: Negligible Periodic maintenance and vehicle traffic would occur.</p>	<p>Construction: Not applicable</p> <p>Operation: Negligible Use of existing wells for groundwater monitoring may require dewatering of the wells; produced water would be re-injected into an existing disposal well.</p>	<p>Construction: Minor Construction may introduce contaminants to storm water runoff through excavation, material delivery and storage, concrete washout, waste generation, and equipment and vehicle use and storage. Wetland impacts were addressed through off-site mitigation banking of 26.2 acres of wetlands. Water required for construction of the parking area would include one water truck supplying an average of 2,000 gallon per day for 3 years. Additional floodplain and wetland impacts may occur at the 40-acre site of the equipment laydown area and methanol/sulfuric acid storage are dependent on the final location selected.</p> <p>The water supply pipeline would cross Bayou d'Inde and Bayou Verdine and impact 3.55 acres of wetlands. The hydrogen pipeline would cross Bayou d'Inde, the Sabine River Canal, and two additional waterbodies using HDD construction methods and impact 3.59 acres of wetlands. Hydrostatic testing of the water supply and hydrogen pipelines would approximately require approximately 193,600 and 412,890 gallons, respectively.</p> <p>Operation: Negligible Operation would use an annual average maximum of 8,500 GPM, or 12.2 million gallons per day of raw water from Sabine River. Wastewater, including cooling tower blowdown, water treatment reject, and plant drains and would be discharged as directed by the LDEQ LPDES Water Discharge Permit.</p>
Groundwater	<i>Included in LCCE Gasification</i>	<p>Construction: Negligible HDD would intersect the shallow unconfined aquifer of the Calcasieu River basin. Area impacted by construction is small compared to the greater than 2 million acres size of the shallow groundwater recharge area.</p>	<p>Construction: Same as proposed route</p>	<p>Construction: Not applicable</p>	<p>Construction: Negligible HDD for the water supply and hydrogen pipelines would intersect the shallow unconfined aquifer of the Calcasieu River basin. Area impacted by construction is small compared to the greater than 2 million acres size of the shallow groundwater recharge area. Small, incidental drips and leaks of</p>

Table 5.1-2 Summary of Unavoidable Environmental Impacts

Resource Area	Lake Charles CCS Project (Proposed Action)			LCCE Gasification (Connected Action)	
	CO ₂ Capture and Compression	Proposed CO ₂ Pipeline Route	Alternative CO ₂ Pipeline Route	West Hastings Research MVA	Gasification Plant Site and Off-site Activities
		<p>Small, incidental drips and leaks of fuels or lubricants could occur from construction equipment or vehicles.</p> <p>Operation: Negligible Small, incidental drips and leaks of fuels or lubricants could occur during maintenance.</p>	<p>Operation: Same as proposed route</p>	<p>Operation: Negligible Small, incidental drips and leaks of fuels or lubricants could occur during maintenance.</p>	<p>fuels or lubricants could occur from construction equipment or vehicles.</p> <p>Operation: Negligible Small, incidental drips and leaks of fuels or lubricants could occur from vehicle traffic.</p>
Biology	<i>Included in LCCE Gasification</i>	<p>Construction: Minor Pipeline construction would affect 10.21 acres of forest, 17.65 acres of scrub-shrub, and 2.1 acres of herbaceous grassland habitats. Biological surveys identified potential and confirmed colonial wading bird nesting area locations east of the proposed CO₂ pipeline corridor.</p> <p>Operation: Negligible Long-term maintenance of the hydrogen pipeline, if it occurs during the breeding season, could cause temporary noise and dislocation of colonial wading birds and species, if present in adjacent forested habitats</p>	<p>Construction: Minor Construction would involve five additional waterbody crossings, and impact 26.29 acres of wetland habitat (versus 2.87 acres for the proposed route). Potential habitat exists for the Crested caracara (Caracara cheriway).</p> <p>Operation: Negligible Long-term maintenance could cause temporary noise and dislocation of colonial wading birds and species, if present in adjacent forested habitats.</p>	<p>Construction: Not applicable</p> <p>Operation: Negligible Reworking of existing wells and use of existing roads would involve the temporary use of truck-mounted equipment.</p>	<p>Construction: Minor Approximately 70 acres of previously disturbed, industrial developed, open space land would be impacted. Clearing of the equipment laydown area could remove 40 acres of potential forested habitat. The water supply pipeline corridor would impact 18.47 and 62.74 acres, respectively of forest habitat potentially used by the red-cockaded woodpecker. Suitable habitat for colonial wading birds may be present along the pipeline route intersections with Bayou D'Inde and around the Houston River.</p> <p>Operation: Negligible Long-term maintenance of the hydrogen pipeline, if it occurs during the breeding season, could cause temporary noise and dislocation of colonial wading birds and species, if present in adjacent forested habitats.</p>
Cultural Resources	<i>Included in LCCE Gasification</i>	<p>Construction: Minor Archaeological site 16CU73 would be destroyed. Directional drilling beneath the cemetery, at a minimum depth of 25 feet below the surface of the Hardey cemetery. Cemetery owners have indicated no objection.</p> <p>Operation: Minor The presence of the buried pipeline may alter the setting of the cemetery.</p>	<p>Construction: Not applicable No CR surveys done for alternative route. If alternative route selected as the preferred alignment for the CO₂ pipeline, Denbuy would conduct CR surveys.</p> <p>Operation: Not applicable (see above)</p>	<p>Construction: Not applicable</p> <p>Operation: None</p>	<p>Construction: Minor Destruction of the portion of archaeological site 16CU29 that is within the APE during ground disturbance associated with clearing, site preparation, and building activities.</p> <p>Operation: None</p>

Table 5.1-2 Summary of Unavoidable Environmental Impacts

Resource Area	Lake Charles CCS Project (Proposed Action)			LCCE Gasification (Connected Action)	
	CO ₂ Capture and Compression	Proposed CO ₂ Pipeline Route	Alternative CO ₂ Pipeline Route	West Hastings Research MVA	Gasification Plant Site and Off-site Activities
Land Use	<i>Included in LCCE Gasification</i>	<p>Construction: Negligible Construction would cause short term impacts to 50.62 acres of temporary ROW which would be restored to previous conditions and uses. 56.34 acres would be impacted long-term, including 8.27 acres of forested land with 2.98 acres of forested wetland.</p> <p>Operation: Negligible Operation of the CO₂ pipeline would require that the area remain clear of woody vegetation and development. Where the pipeline ROW crosses private property, operation of the CO₂ pipeline would restrict landowner uses within the permanent pipeline ROW. Occasional maintenance may require access to buried portions of the pipeline.</p>	<p>Construction: Negligible Construction would impact a total of 187 acres of land, including permanent impacts on 72 acres.</p> <p>Operation: Negligible Same as identified for the proposed route.</p>	<p>Construction: Not applicable</p> <p>Operation: Negligible The research MVA activities are consistent with the existing commercial EOR operation land use.</p>	<p>Construction: Minor The gasification plant would impact 70 acres of industrial property. The raw water pipeline would impact a total of 122 acres of land, including 24 acres of permanent ROW and 98 acres of temporary ROW. The hydrogen pipeline (excluding additional temporary workspace and contractor work sites not within the ROW) would impact a total of 77 acres of land, including 51 acres of permanent ROW and 26 acres of temporary ROW. Surrounding residents and businesses may experience temporary traffic congestion and increased noise and dust levels.</p> <p>Operation: Negligible Occasional maintenance may require access to buried portions of the water supply and hydrogen pipelines.</p>
Socioeconomics and Environmental Justice	<i>Included in LCCE Gasification</i>	<p>Construction: Minor Construction would require an average of 50 workers, with 80 workers at peak. Demand for temporary housing such as hotel/motel rooms, RV sites, and other rental properties would increase providing a benefit to local providers. The area as a whole is not considered an environmental justice area; however certain census tracts have significantly higher proportions of minority and/or Hispanic populations and populations below the poverty level.</p>	<p>Construction: Same as proposed route</p>	<p>Construction: Not applicable</p>	<p>Construction: Minor Construction would temporarily increase employment in the region during the 36-month construction period and would require a peak of 900 workers on site and 2,500 in the surrounding area. The increase in demand for temporary housing would temporarily reduce vacancy rates for such properties throughout the region and would provide short-term economic benefits to owners of temporary housing in the region.</p>

Table 5.1-2 Summary of Unavoidable Environmental Impacts

Resource Area	Lake Charles CCS Project (Proposed Action)			LCCE Gasification (Connected Action)	
	CO ₂ Capture and Compression	Proposed CO ₂ Pipeline Route	Alternative CO ₂ Pipeline Route	West Hastings Research MVA	Gasification Plant Site and Off-site Activities
		<p>Operation: Negligible Two additional workers would be hired to maintain and operate the proposed pipeline route. The workers would be hired locally and would not impact the total population in the Greater Lake Charles area.</p>	<p>Operation: Same as proposed route</p>	<p>Operation: Negligible An additional 14 jobs for 4 months and seven operations jobs for up to 4 years would be created. Census tracts in the area have a significantly larger proportion of minority and/or Hispanic population than Brazoria County or Texas.</p>	<p>Operation: Minor Operation would require 187 new permanent workers. Approximately 90% of these additional workers would be hired from the existing local labor market and 19 permanent workers would relocate to the area.</p>
Traffic and Transportation	<p><i>Included in LCCE Gasification</i></p>	<p>Construction: Minor On average, approximately 100 personnel and 10 trucks would access the pipeline route daily during construction.</p> <p>Operation: Negligible Periodic maintenance of the ROW would include mowing and occasional maintenance activities that may require access to buried portions of the utilities.</p>	<p>Construction: Same as proposed route</p> <p>Operation: Same as proposed route</p>	<p>Construction: Not applicable</p> <p>Operation: Negligible Approximately 14 additional personnel would access the West Hastings research MVA area.</p>	<p>Construction: Minor Approximately 900 workers would access the off-site construction parking area daily. Approximately 150 off-site construction vehicles would deliver concrete, asphalt, and equipment to the site daily during peak construction. Use of Ruth Street during peak construction would degrade LOS from E to F, which is the worst operating condition from a traveler's perspective.</p> <p>Operation: Negligible Approximately 187 personnel would access the site during operation. Approximately 81 one-way truck trips would access the site daily to remove waste materials or deliver materials.</p>
Noise	<p>Construction: <i>Included in LCCE Gasification</i></p>	<p>Construction: Minor Sound levels may exceed EPA and HUD guidelines at some residences during pipeline construction. HDD activities may need to be conducted in the evening or weekends within 165 feet of a residence or noise sensitive area, which is prohibited by Calcasieu Parish and Cameron Parish ordinances without a variance.</p>	<p>Construction: Minor Impact similar to proposed route, 10 residences within 50 feet of the line instead of eight.</p>	<p>Construction: Not applicable</p>	<p>Construction: Minor Potential sound level assuming two simultaneous pile driving operations at edge of site during plant construction (64 dBA) exceeds EPA day-night average guideline L_{dn} of 55 dBA and ambient background L_{eq} of 60 dBA. Sound level expected to be barely perceptible due to industrial setting.</p> <p>Sound levels from construction of the hydrogen and water supply pipelines may exceed EPA and HUD guidelines. For the water supply pipeline, HDD activities may need to be conducted in the evening or weekends within 165 feet of a residence or noise sensitive area, which is prohibited by Calcasieu Parish ordinances without a variance.</p>

Table 5.1-2 Summary of Unavoidable Environmental Impacts

Resource Area	Lake Charles CCS Project (Proposed Action)			LCCE Gasification (Connected Action)	
	CO ₂ Capture and Compression	Proposed CO ₂ Pipeline Route	Alternative CO ₂ Pipeline Route	West Hastings Research MVA	Gasification Plant Site and Off-site Activities
	<p>Operation: Negligible The compressors contribute 49 dBA at the nearest receptor location.</p>	<p>Operation: Negligible Noise would be generated from equipment and vehicles used during pipeline inspection and maintenance activities.</p>	<p>Operation: Negligible Noise would be generated from equipment and vehicles used during pipeline inspection and maintenance activities.</p>	<p>Operation: Negligible Sound levels from operation of a small drill rig and supporting equipment would most likely be imperceptible due to industrial setting.</p>	<p>Operation: Negligible Leucadia equipment estimated sound level at nearest noise receptor would exceed the EPA L_{dn} of 55 dBA but would not exceed the ambient background L_{eq} of 60 dBA.</p>
Wastes	<p><i>Included in LCCE Gasification</i></p>	<p>Construction: Negligible Following HDD operations, the bentonite slurry would be recycled, spread in upland areas as a soil supplement, if permitted, or removed and disposed of at a local permitted solid waste landfill.</p> <p>Operation: Negligible Waste generation would be limited to periodic ROW maintenance activities including mowing of ground cover, clearing of vegetation, maintenance of access and service roads, and servicing and monitoring of pipeline system components.</p>	<p>Construction: Same as proposed route</p> <p>Operation: Same as proposed route</p>	<p>Construction: Not applicable</p> <p>Operation: Negligible Produced water and light sediment would be pumped into trucks and hauled off site by a licensed contractor for disposal. Excess drilling mud would be collected and stabilized in steel tanks and transported off site to a designated local solid waste landfill per Denbury's current operating practices.</p>	<p>Construction: Negligible Assuming no recycling of construction waste, approximately 2,640 cubic yards of nonhazardous waste and small quantities of hazardous waste would be generated annually during the 3-year construction period, or less than 0.0002% of the available landfill capacity in Calcasieu Parish.</p> <p>Operation: Negligible Assuming no recycling, approximately 65,000 tons (75,000 cubic yards) of nonhazardous waste generated annually during operation represents 0.6% of the total landfill capacity in Calcasieu Parish. Approximately 1,500 cubic yards of potentially hazardous waste would be generated annually during operation, or less than 0.03% of the capacity of the hazardous waste landfills in Calcasieu Parish.</p>
Materials	<p>Construction: <i>Included in LCCE Gasification</i></p>	<p>Construction: Minor Construction would require materials such as carbon steel pipe, valves, pumps, fittings, process materials, cathodic protection equipment, controls and monitoring systems. Also, fuel, lubricants, transmission fluids, and oils would be required for the operation and maintenance of equipment and vehicles.</p>	<p>Construction: Same as proposed route</p>	<p>Construction: Not applicable</p>	<p>Construction: Minor Construction materials would consist of concrete, wood, fuel, and steel. Construction materials and specialized construction equipment are readily available from in-state and regional vendors and fabricators. Locally obtained materials would include crushed stone, sand, and lumber for the proposed facilities and temporary structures. Construction would require small volumes of commercially available chemicals, including paints and cleaners, and materials for operating and maintaining vehicles and equipment (lubricants, transmission fluids, oils).</p>

Table 5.1-2 Summary of Unavoidable Environmental Impacts

Resource Area	Lake Charles CCS Project (Proposed Action)			LCCE Gasification (Connected Action)	
	CO ₂ Capture and Compression	Proposed CO ₂ Pipeline Route	Alternative CO ₂ Pipeline Route	West Hastings Research MVA	Gasification Plant Site and Off-site Activities
	<p>Operation: Negligible Methanol and propylene would be the primary materials used. CO₂ would be used or produced. Operation would occur as an integrated component of the LCCE Gasification plant.</p>	<p>Operation: Negligible Supercritical CO₂, which flows like a liquid, would be transported via the pipeline. Fuel, lubricants, transmission fluids, and oils would be required for the operation and maintenance of equipment and vehicles used for routine maintenance and monitoring of the pipeline and pipeline system components.</p>	<p>Operation: Same as proposed route</p>	<p>Operation: Negligible Materials used include fuels, oils, lubricants, corrosion inhibitors, ready-mix concrete, gravel fill, reinforcing steel, equipment rentals, piping, fittings, valves, and welding materials.</p>	<p>Operation: Negligible Petcoke, fluxant, fuel, aqueous ammonia, and chlorine would be the primary materials used. Operation would use or produce industrial chemicals, including aqueous ammonia, methanol, sulfuric acid, hydrogen, and fuels.</p>
Human Health and Safety	<p><i>Included in LCCE Gasification</i></p>	<p>Construction: Negligible An estimated 1.08 OSHA-recordable cases and 0.6 cases with days away would be anticipated during the construction of the CO₂ pipeline based on national incidence rates and 250 employees during the peak construction period. Based on fatality rates for construction and extraction sector, the fatality rate would be below one (0.01) and no fatalities would be expected. It is not expected that the public would be on site or be exposed to chemical or industrial hazards or contaminants that would exceed public health standards.</p> <p>Operation: Negligible An estimated 1.35 OSHA-recordable cases and 1.08 cases with days away would be anticipated during a 30-year life of the pipeline, based on national incidence rates and the estimated number of workers employed during operation of the pipeline.</p>	<p>Construction: Same as proposed route</p> <p>Operation: Same as proposed route</p>	<p>Construction: Not applicable</p> <p>Operation: Negligible Potential health impacts on workers would be typical of those for the ongoing commercial EOR operation and commercial MVA program.</p>	<p>Construction: Negligible An estimated 84 OSHA recordable cases and 46 cases with days away would be anticipated during construction based on national incidence rates and the estimated 900 construction workers employed on site during peak construction. The public would not have access to the constructions area. Vehicle emissions would not expose sensitive receptors to substantial pollutant concentrations.</p> <p>Operation: Negligible An estimated 62 OSHA-recordable cases and 34 cases with days away would be anticipated during operation based on national incidence rates and the estimated 187 workers employed during the 30-year life of the plant. Based on fatality rates for petroleum refineries, the fatality rate would be below 1 (0.02) and no fatalities would be expected. Air emissions of criteria pollutants and toxic air pollutants do not cause or contribute to any violation of the ambient air quality standards or expose sensitive receptors to substantial pollutant concentrations.</p>

Table 5.1-3 Indicators of Importance for Cumulative Effects Issues

Indicator	Factors
High importance	<ul style="list-style-type: none"> ■ The incremental effect, alone, would generally be considered a significant impact, as this phrase is used in context of NEPA review and analysis. ■ An analysis of cumulative effects for this issue would be required to support a reasoned-decision among the alternatives. ■ Society, in general, has a history or record of being concerned about this type of cumulative effect, and two or more of the factors of intermediate importance are present.
Intermediate importance	<ul style="list-style-type: none"> ■ There is a regulatory/resource threshold or physical limit (e.g., utility capacity) that might be exceeded or that is approaching an exceedance in the cumulative effect and this potential exceedance of the threshold or physical limit is of significance from the viewpoint of NEPA review, federal decision making, and public disclosure. ■ There is a governmental organization or nationally recognized nongovernmental organization that has a history or record of being concerned about the cumulative effect. ■ The cumulative effect issue was raised during the scoping process by either a governmental organization or by more than one nongovernmental entity or person, and the particular issue is relevant or consequential in federal decision making. ■ Issue is indicated to be important judging by the fact that one or more governmental or nongovernmental organizations have published statistics or trends on the issue.
Lesser importance	<ul style="list-style-type: none"> ■ Issues not having any of the factors listed in the two categories above. ■ Issues identified as having either a high- or intermediate-level of importance were given to resource specialists for further investigation.

Table 5.1-4 Cumulative Effects Matrix

Resource Area	Construction/ Operations Direct and Indirect Impacts	Indicators of Importance for Cumulative Effects Issues	Indicator Criteria (from Table 5.1-3)	Incremental Cumulative Effects
Air Quality	Negligible/Minor or	High	Society, in general, has a history or record of being concerned about this type of cumulative effect, and two or more of the factors of intermediate importance are present.	<ul style="list-style-type: none"> ■ Contribution of Lake Charles CCS and LCCE Gasification emissions when added to “background” concentrations and projected future emissions.
Climate	Minor	High	Society, in general, has a history or record of being concerned about this type of cumulative effect, and two or more of the factors of intermediate importance are present.	<ul style="list-style-type: none"> ■ Contribution of Lake Charles CCS and LCCE Gasification emissions of GHGs when added to “background” concentrations and projected future concentrations.
Surface Water (wetlands)	Minor	High	There is a governmental organization or nationally recognized nongovernmental organization that has a history or record of being concerned about the cumulative effect.	<ul style="list-style-type: none"> ■ Wetland loss and/or modification. ■ Alteration of floodplains resulting in a higher potential for flooding.
Geology	Minor	Intermediate	The cumulative effect issue was raised during the scoping process by either a governmental organization or by more than one nongovernmental entity or person, and the particular issue is relevant or consequential in federal decision making.	<ul style="list-style-type: none"> ■ Potential for locally induced increase in seismic activity or other geologic hazards. ■ Potential for migration of injected CO₂ outside EOR area.
Soils	Minor	Intermediate	The cumulative effect issue was raised during the scoping process by either a governmental organization or by more than one nongovernmental entity or person, and the particular issue is relevant or consequential in federal decision making.	<ul style="list-style-type: none"> ■ Disturbance of soils during the construction and/or operations phase of the projects. ■ Conversion of soils classified as Prime Farmland (or other important classifications). ■ Increase in soil erosion and soil loss.
Biology	Minor	Intermediate	There is a governmental organization or nationally recognized nongovernmental organization that has a history or record of being concerned about the cumulative effect.	<ul style="list-style-type: none"> ■ Habitat loss, habitat fragmentation, and wildlife displacement associated with land development. ■ Loss or change in vegetation in disturbed areas from native to non-native species. ■ Fish and wildlife mortality and impacts on protected species.

Table 5.1-4 Cumulative Effects Matrix

Resource Area	Construction/ Operations Direct and Indirect Impacts	Indicators of Importance for Cumulative Effects Issues	Indicator Criteria (from Table 5.1-3)	Incremental Cumulative Effects
Local Traffic	Minor	Intermediate	The cumulative effect issue was raised during the scoping process by either a governmental organization or by more than one nongovernmental entity or person, and the particular issue is relevant or consequential in federal decision making.	<ul style="list-style-type: none"> ■ Increases of local (Louisiana and Texas) vehicular traffic.
Regional Traffic and Transportation	Minor	Intermediate	The cumulative effect issue was raised during the scoping process by either a governmental organization or by more than one nongovernmental entity or person, and the particular issue is relevant or consequential in federal decision making.	<ul style="list-style-type: none"> ■ Increase in vehicle traffic as a contribution to transportation patterns and systems trends (increasing or decreasing) in the regional project areas (Louisiana and Texas).
Socio Economics	Minor	Intermediate	There is a governmental organization or nationally recognized nongovernmental organization that has a history or record of being concerned about the cumulative effect.	<ul style="list-style-type: none"> ■ Benefit of Lake Charles CCS as a demonstration that, along with other DOE CCS program initiatives, would promote CO₂-based EOR as a means of sequestration of CO₂; MVA as a means of accounting and certifying the sequestration; and as a precedent that would encourage the geologic sequestration of CO₂, and the re-development of natural resources now considered depleted. ■ Benefit of expansion of anthropogenic CO₂ supply, resulting in increasing domestic oil production and associated job creation, expanding federal and state revenues, and declining CO₂ emissions.

5.2 Cumulative Effects of High Importance

This section addresses potential cumulative effects as a result of construction and operation of the Lake Charles CCS project and specific future proposals and general trends in the cumulative effects in the area of influence. DOE identified three cumulative effects issues—Air Quality, GHG emissions, and surface water quality—as having high importance. GHG emissions are widely associated with global climate change, a topic of national debate. Furthermore, during the public scoping process for this EIS, cumulative impacts were identified as an important environmental issue for the people of the Gulf Coast.

5.2.1 Air Quality

For air quality, the dispersion modeling analysis in Section 4.2.2.2.1 indicates that the maximum predicted concentrations would be less than the SILs for all criteria pollutants. The SIL is a threshold concentration established by EPA New Source Review Guidance that signifies, when exceeded, that an ambient concentration has the potential to be exceeded and would indicate that an emission source has the potential for a cumulative impact with nearby emissions sources. SIL threshold concentrations are much lower than national ambient air quality standards, generally ranging from 1% to 5% of a NAAQS (see Table 4.2-6 in Section 4.2.2.2.1). Given the low threshold concentrations assigned to SILs, when modeled maximum concentrations are less than the SIL value for the applicable pollutant and averaging time, the conclusion is that the proposed source would not have a cumulative impact with other nearby or distant sources. Therefore, modeling of the potential for cumulative impacts would not be required under CAA permitting or under NEPA, and the LCCE Gasification plant would not have an incremental cumulative impact for criteria pollutants with the projects shown in Table 5.1-1.

5.2.2 Climate Change

A worldwide environmental issue is the likelihood of changes in the global climate as a consequence of global warming produced by increasing concentrations of atmospheric GHGs (International Panel on Climate Change [IPCC] 2007a). The atmosphere allows a large percentage of incoming solar radiation to pass through to the earth's surface, where it is converted to heat energy (infrared radiation), which is more readily absorbed by GHGs such as CO₂ and water vapor than incoming solar radiation. The heat energy absorbed near the earth's surface increases the temperature of air, soil, and water.

GHGs include water vapor, CO₂, methane, nitrous oxide, ozone, and several chlorofluorocarbons. GHGs constitute a small percentage of the earth's atmosphere. Water vapor, a natural component of the atmosphere, is the most abundant GHG. The second-most abundant GHG is CO₂, which remains in the atmosphere for long periods of time. Due to anthropogenic activities, atmospheric CO₂ concentrations have increased by approximately 35 percent over preindustrial levels. Fossil fuel burning, especially from power production and transportation, is the primary contributor to increasing concentrations of CO₂ in the atmosphere (IPCC 2007a). In the United States, stationary CO₂ emission sources include energy facilities and industrial plants. Industrial processes that emit these gases include cement manufacture, limestone and dolomite calcination, soda ash manufacture and consumption, CO₂ manufacture, and aluminum production (EIA 2009a).

In the preindustrial era (before ca. A.D. 1750), the concentration of CO₂ in the atmosphere appears to have been in the range of 275 to 285 ppm (IPCC 2007a). In 1958, C.D. Keeling and others began measuring the concentration of atmospheric CO₂ at Mauna Loa in Hawaii (Keeling

et al. 1976). The data collected by Keeling's team and others since then indicate that the amount of CO₂ in the atmosphere has been steadily increasing from approximately 316 ppm in 1959 to 396 ppm in 2013 (NOAA 2013). This recent increase in atmospheric CO₂ is attributed almost entirely to the anthropogenic activities noted previously. In addition, industrial and agricultural activities release GHGs other than CO₂—notably methane, NO_x, ozone, and chlorofluorocarbons—to the atmosphere, where they can remain for long periods of time.

Without CO₂ capture, the LCCE Gasification plant, operating at full capacity, is permitted to emit 5,840,387 tpy of CO₂ equivalents (CO₂e) per year while gasifying petcoke. Assuming CO₂ capture of 89%, the facility would emit 642,443 tpy of CO₂e. DOE estimates that petcoke transport could increase annual GHG emissions attributable to the operation of the LCCE Gasification by approximately 5,000 tons (for a total of approximately 5.8 million tons annually). GHG emissions from the transport of petcoke would primarily result from the combustion of diesel fuel in tugs used for barge delivery. These emissions would represent less than 0.8 % of the annual LCCE Gasification plant emissions. Total emissions of GHGs from construction activities are estimated to be 13,112 tons of CO₂e per year, or less than 1% of 1 year's operating emissions.

Operating at full capacity without beneficial use of CO₂ for EOR and geologic storage, the facility would constitute one of the larger point sources of CO₂ emissions in Louisiana. GHGs are regulated at the federal level through the New Source Review permit program of the CAA for sources emitting greater than 100,000 tons of GHGs per year. Annual mandatory reporting of GHGs is also required by federal law for large GHG emissions sources, generally those emitting greater than 25,000 tons per year CO₂e. The GHGs emitted by the LCCE Gasification Plant would add a relatively small increment to emissions of these gases in the United States and the world. Overall GHG emissions in the United States during 2010 totaled approximately 7,519.7 million tons (6,821.8 million metric tonnes) of CO₂e, including approximately 6,290.2 million tons (5,706.4 million metric tonnes) of CO₂. These emissions resulted primarily from fossil fuel combustion. Approximately 14% of CO₂ emissions came from industrial sources using fossil fuels (EPA 2012).

The release of anthropogenic GHGs and their potential contribution to global warming are inherently cumulative phenomena. That is, emissions of GHGs from the proposed project would not, by themselves, have a direct impact on the global, regional, or local environment. Similarly, current scientific methods do not allow one to correlate emissions from a specific source with a particular change in either local or global climates.

Impacts of GHGs on Climate

Climate is usually defined as the average weather of a region or, more rigorously, as the statistical description of a region's weather in terms of the means and variability of relevant parameters over time periods ranging from months to thousands of years. The relevant parameters include temperature, precipitation, wind, and dates of meteorological events such as first and last frosts, beginning and end of rainy seasons, and appearance and disappearance of pack ice. Because GHGs in the atmosphere absorb energy that would otherwise radiate into space, the possibility that anthropogenic releases of these gases could result in warming that might eventually alter climate was recognized soon after the data from Mauna Loa and elsewhere confirmed that the atmosphere's content of CO₂ was steadily increasing (IPCC 2007a).

Changes in climate are difficult to detect because of the natural and complex variability in meteorological patterns over long periods of time and across broad geographical regions¹. There is much uncertainty regarding the extent of global warming caused by anthropogenic GHGs, the climate changes this warming has or will produce, and the appropriate strategies for stabilizing the concentrations of GHGs in the atmosphere. The World Meteorological Organization (WMO) and United Nations Environment Programme (UNEP) established the IPCC to provide an objective source of information about global warming and climate change, and IPCC's reports are generally considered to be an authoritative source of information on these issues.

According to the IPCC's fourth assessment report, "[w]arming of the climate system is unequivocal, as is now evident from observations of increases in global average air and ocean temperatures, widespread melting of snow and ice, and rising global average sea level" (IPCC 2007b). The IPCC report finds that the global average surface temperature has increased by approximately 0.74°C (approximately 1.2 to 1.4°F) in the last 100 years; global average sea level has risen approximately 150 millimeters over the same period; and cold days, cold nights, and frosts over most land areas have become less frequent during the past 50 years. The report concludes that most of the temperature increases since the middle of the twentieth century "is very likely due to the observed increase in anthropogenic [GHG] concentrations." The 2007 report estimates that, at present, CO₂ accounts for approximately 77 percent of the global warming potential attributable to anthropogenic releases of GHGs, with the vast majority (74 percent) of this CO₂ coming from the combustion of fossil fuels. Although the report considers a wide range of future scenarios regarding GHG emissions, CO₂ would continue to contribute more than 70 percent of the total warming potential under all of the scenarios. The IPCC therefore believes that further warming is inevitable, but that this warming and its effects on climate could be mitigated by stabilizing the atmosphere's concentration of CO₂ through the use of: (1) low-carbon technologies for power production and industrial processes, (2) more efficient use of energy, and (3) management of terrestrial ecosystems to capture atmospheric CO₂ (IPCC 2007b).

Environmental Impacts of Climate Change

The IPCC and the U.S. Climate Change Science Program (CCSP) have examined the potential environmental impacts of climate change at global, national, and regional scales. The IPCC report states that, in addition to increases in global surface temperatures, the impacts of climate change on the global environment may include:

- More frequent heat waves, droughts, and forest fires.
- Rising sea levels and coastal flooding.
- Melting glaciers, ice caps, and polar ice sheets.
- More severe hurricane activity and increases in frequency and intensity of severe precipitation.

¹ Detection of these types of changes was also difficult because of the limited tools that were available for collecting data and for modeling climate systems. However, scientific advances over the last 20 years have vastly improved the tools available for climatological research.

- Spread of infectious diseases to new regions.
- Loss of wildlife habitats.
- Heart and respiratory ailments from higher concentrations of ground-level ozone (IPCC 2007b).

On a global scale, the average surface temperature has increased approximately 1.2 to 1.4°F since 1900, with the 10 warmest years on record all occurring in the past 13 years (EPA 2012). Impacts on the environment attributed to climate change that have been observed in North America include:

- Extended periods of high fire risk and large increases in burned area.
- Increased intensity, duration, and frequency of heat waves.
- Decreased snow pack, increased winter and early spring flooding potentials, and reduced summer stream flows in the western mountains.
- Increased stress on biological communities and habitats in coastal areas (IPCC 2007b).

On a regional scale, there is greater natural variability in climate parameters, which makes it difficult to attribute particular environmental impacts to climate change (IPCC 2007b). However, based on observational evidence, there is likely to be an increasing degree of impacts such as coral reef bleaching, loss of specific wildlife habitats, reductions in the area of certain ecosystems, and smaller yields of major cereal crops in the tropics. For the northern hemisphere, regional climate change could affect physical and biological systems, agriculture, forests, and amounts of allergenic pollens².

In the region where the LCCE Gasification Plant would be located, the average temperature increased by 0.3°F between 1901 and 2008, however the average temperature increased by 1.6°F between 1970 and 2008. Average annual precipitation in the southeastern region of the United States decreased 7.7% from 1970-2008. Over the last century, annual precipitation increased by 6.0% and average autumn precipitation increased by approximately 30% (USGCRP 2009). During the next century, Louisiana's climate may change even more: climate models predict the rate of warming in the southeastern United States to more than double through the end of the century (USGCRP 2009)

Addressing Climate Change

Because climate change is a cumulative phenomenon produced by releases of GHGs from industry, agriculture, and land use changes around the world, it is generally accepted that any successful strategy to address it must rest on a global approach to controlling these emissions. In other words, imposing controls on one industry or in one country is unlikely to be an effective strategy. And because GHGs remain in the atmosphere for a long time and industrial societies will continue to use fossil fuels for at least 25 to 50 years, climate change cannot be avoided. As

² The IPCC report provides more detailed information on the current and potential environmental impacts of climate change and on how climate may change in the future under various scenarios of GHG emissions.

the IPCC report states, “[s]ocieties can respond to climate change by adapting to its impacts and by reducing [GHG] emissions (mitigation), thereby reducing the rate and magnitude of change” (IPCC 2007b).

According to the IPCC, there is a wide array of adaptation options. While adaptation will be an important aspect of reducing societies’ vulnerability to the impacts of climate change over the next two to three decades, “adaptation alone is not expected to cope with all the projected effects of climate change, especially not over the long term as most impacts increase in magnitude” (IPCC 2007). Therefore, it will also be necessary to mitigate climate change by stabilizing the concentrations of GHGs in the atmosphere. Because these gases remain in the atmosphere for long periods of time, stabilizing their atmospheric concentrations will require societies to reduce their annual emissions. The stabilization concentration of a particular GHG is determined by the date that annual emissions of the gas start to decrease, the rate of decrease, and the persistence of the gas in the atmosphere. The IPCC report predicts the magnitude of climate change impacts for a range of scenarios based on different stabilization levels of GHGs. “Responding to climate change involves an iterative risk management process that includes both mitigation and adaptation, taking into account actual and avoided climate change damages, co-benefits, sustainability, equity, and attitudes to risk” (IPCC 2007b).

5.2.2.1 Climate Change, GHGs, and the LCCE Gasification Plant

DOE estimates that annual emissions of GHGs from the LCCE Gasification plant would be approximately 0.63 million tpy of CO₂e. Over the 30-year commercial life of the project, total emissions would be up to approximately 19 million tons. The estimates of emissions take into account the CO₂ removal that would result from carbon capture and sequestration. As mentioned earlier, the plant would be designed to capture and sequester approximately 89% of the CO₂ created in the methanol and hydrogen production process. The 0.64 million tons of annual emissions of GHGs would add to the approximately 857.4 million tons (777.8 million metric tonnes) of CO₂ emissions released annually from the industrial sector in the United States (EPA 2012). Globally, approximately 33,414 million tons (30,313 million metric tonnes) of CO₂ was emitted by the use of fossil fuel in 2009 (EPA 2012). However, it cannot be assumed that, if the LCCE Gasification Plant were not built, these additional emissions would be avoided—other less efficient and/or more CO₂-emitting plants could be built, or existing plants might increase their production and fuel consumption, thereby increasing their CO₂ emissions.

As noted earlier, emissions of GHGs from the LCCE Gasification Plant by themselves would not have a direct impact on the environment in the proposed plant’s vicinity; neither would these emissions by themselves cause appreciable global warming that would lead to climate changes. However, these emissions would increase the atmosphere’s concentration of GHGs, and, in combination with past and future emissions from all other sources, contribute incrementally to the global warming that produces the adverse effects of climate change described previously. At present there is no methodology that would allow DOE to estimate the specific impacts (if any) this increment of warming would produce in the vicinity of the plant or elsewhere.

Climate Change, Greenhouse Gases, and ICCS

As described in more detail in Section 1.1, the ICCS program provides funding to the private sector for projects intended to demonstrate advanced technologies that integrate CO₂ capture at industrial sources and monitor the sequestration of CO₂ in underground formations. Demonstrations of technologies that increase efficiency, facilitate carbon capture, and sequester

CO₂ are important steps in developing strategies for stabilizing atmospheric concentrations of GHGs. The IPCC report states that there is high agreement that atmospheric concentrations can be stabilized by “deployment of a portfolio of technologies that are either currently available or expected to be commercialized in coming decades assuming that appropriate and effective incentives are in place for their development.” DOE is providing appropriate incentives for developing technologies that can address global warming and the adverse environmental impacts of climate change.

5.2.3 Surface Water

As described in Section 4.4, construction and operation of the proposed project and the connected action would result in potential impacts on surface water from land clearing, wetland and floodplain fills, and storm water discharges. These potential minor impacts, which would be temporary (in the case of pipeline installation) or mitigated to achieve no net loss of wetlands (in the case of the proposed project and connected action), are considered in the context of reasonably foreseeable projects to assess their incremental cumulative effect on surface water resources.

Louisiana coastal areas have lost over 1,205,120 acres (482,048 ha) of wetlands and associated floodplains since the 1930s (USGS 2012). As recently as the 1970s, the loss rate for Louisiana coastal wetlands was as high as 25,600 acres (10,360 ha) per year. The current rate of wetland loss is about 106,050 acres (42,917 ha) per year. Studies estimate that Louisiana will experience a 3,922,184-acre (1,587,920 ha) net loss of wetlands by the year 2050 (Louisiana Coast 2012).

Table 5.2-1 below summarizes the surface water impacts of the proposed project and connected action showing a total loss of 92.36 acres of wetlands will result from the LCCE project. DOE evaluated USACE New Orleans District records, which identified 14 pending projects within Calcasieu Parish with the potential to impact 54.2 acres of wetlands within the Bayou D’Inde watershed or along the Houston or Calcasieu rivers. Table 5.5-2 summarizes the potential cumulative wetland impacts from the proposed project and connected action, pending projects, and from natural causes in Calcasieu Parish. Natural causes refer to the annual rate of wetland loss from subsidence, sea level rise, and erosion. Calcasieu Parish contains approximately 328,225 acres within a flood hazard area and approximately 15,360 acres of wetlands and open water areas. The Louisiana Office of Coastal Protection and various federal agencies, including the USACE, address the annual rate of Louisiana coastal wetland loss through numerous wetland restoration projects. The cumulative wetland impact, including those anticipated from natural causes is 1,667 acres, which represents 10.8% of the wetlands in Calcasieu Parish and 1.6% of the overall wetland loss in Louisiana. Wetland loss from human impacts without loss from natural causes represents 131 acres, or 0.8% of wetlands in Calcasieu Parish.

Table 5.2-1 Summary of Surface Water Impacts for the Proposed Project and Connected Action

	Waters of the U.S.	Wetland (acres)
Connected Action		
LCCE Gasification	0	26.2
Construction parking	0	0
Equipment laydown and methanol/sulfuric acid storage ¹	0	40
Linears for natural gas, potable water, transmission, sulfuric acid, and methanol	0	0

Table 5.2-1 Summary of Surface Water Impacts for the Proposed Project and Connected Action

	Waters of the U.S.	Wetland (acres)
Raw water pipeline	0	3.55
Hydrogen pipeline	0	3.59
Subtotal		73.34
Proposed Project		
CO ₂ Capture and Compression ²		-
CO ₂ pipeline ³	Houston River Bayou D Inde	19.02
Hastings Research MVA	0	0
Subtotal		19.02
Total		92.36

Notes:

- ¹ The final location of this area has not been determined; however, for the purposes of this analysis, the location is considered to be within close proximity of the LCCE Gasification site and assumed to impact a maximum of 40 acres of wetlands and floodplain.
- ² Included in LCCE Gasification.
- ³ Total potential temporary and permanent impacts.

Table 5.2-2 Summary of Cumulative Impacts on Wetlands

	Wetland (acres)
Proposed Project	19.02
Connected Action	73.34
Foreseeable Future Projects	
14 planned projects	54.2 ¹
Natural causes within Calcasieu Parish	1,536 ²
Natural causes within coastal Louisiana	106,050 ²
Total	107,733

Notes:

- ¹ Proposed projects in Calcasieu Parish according to USACE New Orleans District; offset through mitigation in CWA 404 permit process.
- ² Per year over the life of the proposed project; also offset in part (3.6 million acres) by Louisiana OCPR restoration projects.

Permits for impacting jurisdictional waters of the U.S., including wetland filling, require mitigation or compensation to ensure there is no net loss of jurisdictional waters of the U.S., including wetlands within the watershed. Mitigation options include wetland and stream restoration, creation, or preservation in the watershed and use of authorized mitigation sites. Lake Charles CCS and Denbury, as well as each project with the permit requirement to mitigate for their individual impacts, would implement one of these mitigation options. Therefore, adoption of the proposed action would not result in significant cumulative impacts on surface water.

5.3 Cumulative Effects of Intermediate Importance

This section addresses potential cumulative effects as a result of construction and operation of the Lake Charles CCS project and specific future proposals and general trends in the cumulative effects in the area of influence. DOE identified these five cumulative effects issues as having effects of intermediate importance.

5.3.1 Geology and Soils

The Hastings oil field has been a productive oil field since 1934, with oil production through 1984 totaling 656.2 million barrels, of which 108.4 million were from the Hastings East Field and 547.8 million were from the West Hastings oil field (Daniels 2012). After hitting a peak production of 75,000 barrels per day in the mid-1970s, rates steadily declined until Denbury began EOR activities in the field in 2011. Current production is 1,900 barrels per day (Denbury 2012).

Injection of CO₂ into the Frio Formation sand units is expected to have the beneficial impact of allowing continued production of oil and gas from these units within the West Hastings oil field. It is anticipated that the injection process and subsequent movement of the CO₂ is expected to force the migration of hydrocarbon fluids to the proposed EOR oil production wells, boosting oil production rates by approximately 25% to 50%, or maintaining oil production rates at current levels as opposed to continued decline.

DOE evaluated the potential incremental cumulative impacts of CO₂ injection from the Lake Charles CCS project and the Air Products CCS project in the West Hastings oil field and the Gulf Coast area. The Lake Charles and Air Products projects during the two year West Hastings research MVA period would capture, compress, and transport approximately 9.2 and 2 million tons, respectively, of anthropogenic CO₂ for use in Denbury's ongoing commercial EOR operations. This volume represents approximately 40 % of the total estimated 28 million tons of CO₂ storage capacity of the Hasting oil field (DOE 2010). The proposed injection volumes are well within the available capacity and would not have a cumulative impact on the West Hastings oil field.

The proposed West Hastings research MVA program could have a positive impact of encouraging additional CO₂ capture activities by confirming storage of CO₂ injected in EOR operations along the Gulf Coast. Currently, more than 100 CO₂ injection projects produce more than 250,000 barrels of oil per day in the U.S., and due to CO₂ availability from Jackson Dome, several CO₂ EOR projects have been implemented in the Gulf Coast, such as the current EOR at West Hastings, and other projects in Mississippi (Zhou et al. 2012). According to a 2005 report by Advanced Resources International prepared for DOE (ARD 2005) the miscible CO₂ EOR resource potential along the Gulf Coast is approximately 5 billion barrels of oil. Similarly, the Gulf Coast Carbon Center (GCCC) of the BEG categorized and identified approximately 1,700 oil reservoirs that would be candidates to produce extra oil through EOR, ranging from tens of thousands to hundreds of millions of barrels (King et al. 2009). The expansion of CO₂ EOR operations in the Gulf Coast would create a greater demand for CO₂ capture, transport, and injection (NETL 2011). Based on market conditions, additional CO₂ emissions reductions would occur from industrial sources. The associated infrastructure for capture equipment and pipelines would be required to support the industry expansion, with corresponding construction impacts and benefits. Capture equipment would be installed at existing industrial facilities with minimal incremental impacts. Furthermore, expansion of the onshore pipeline network needed to transport anthropogenic CO₂ from producers to potential EOR fields (and eventual geologic sequestration) would use existing rights-of-way (ROW) to the maximum extent practicable, as all oil fields have, to some extent, an existing pipeline infrastructure. Positive benefits would accrue from construction and operation of existing and under-used pipeline networks, and pipelines connected to the source of CO₂ could minimize the amount of new pipelines needed

(MIT 2010). The expansion of CO₂ EOR operations along the Gulf Coast would also have a positive socioeconomic impact, as described in Section 5.3.4.

The Gulf Coast area is seismically stable, and EOR practices are designed to prevent conditions that would cause instability. A report in 2012 by the Board on Earth Science and Resources evaluated the potential for induced seismicity from energy technologies, including geothermal, oil and gas, waste water disposal, and carbon capture and storage (NAS2012). The report indicates approximately 13,000 wells in the U.S. are used for EOR, including CO₂ injection. There have been no known “felt” events associated with any of these 13,000 wells. In addition, the data indicate that other types of oil- and gas-related development also have statistically low occurrences of induced felt seismic events (NRC 2012). Considering the known seismic stability of the local area and the Gulf Coast region, as well as data on the practice of CO₂ EOR nationally, adoption of the proposed action alternative would not result in significant cumulative impacts on geological resources such that it would increase the potential for seismic activity in the Gulf Coast area.

Overall soil loss and disturbance in the Gulf Coast area has generally followed the historic trends of land development. In general, potential minor impacts on physiography and soils would include disturbance of soils from grading, excavation activities, earthwork compaction, installation of impermeable surfaces over soils at some locations (soil loss), and increased soil erosion. It is unlikely that large areas classified as prime farmland that could be used for agricultural production would be lost, as many of the Gulf Coast projects would be located within industrial landscapes (i.e., existing oil and gas fields), a ROW, and/or established municipalities. Minor incremental cumulative impacts would be expected overall, and the contribution by the project would also be considered minor. Although prime farmland soils would be disturbed or lost as a result of the projects, these land areas would otherwise likely not be available for agricultural production due to the nature of their locations. (Daniels 2012)

5.3.2 Biology

As described in Section 4.6, construction of the proposed project and the connected action would result in the conversion of some existing forest to maintained open grassland, which would affect the wildlife communities using these habitats. These impacts are considered in the context of reasonably foreseeable projects to assess their incremental cumulative effect on forest as habitat for native and migratory terrestrial and aquatic species.

Bird species of highest concern in forested wetland areas include migratory bird species, including the Swainson’s warbler (*Limnothlypis swainsonii*), swallow-tailed kite (*Elanoides forficatus*), cerulean warbler (*Setophaga cerulean*), prothonotary warbler (*Protonotaria citrea*), Kentucky warbler (*Geothlypis formosa*), and yellow-billed cuckoo (*Coccyzus americanus*).

Table 5.3-1 summarizes potential cumulative impacts on forested area for the proposed project, connected action, and reasonably foreseeable future projects. Past forest impacts within the Bayou D’Inde watershed account for the removal of approximately 50% of the historic forest cover. Of the projects listed in Table 5.1-1, the Lake Charles Port Facility Expansion project, Sasol project, and Trunkline project would potentially result in clearing and loss of forest. As described in Section 4.6.2.1.1, the proposed action and connected action are located within the contiguous 1,740-acre forested area of the Bayou D’Inde watershed, the 6,220 acres of forested area within the Upper Calcasieu River watershed, and the 100,480 acres of forested area within

the Houston River watershed. Cumulatively, the projects would result in the potential loss of 5.8% of remaining forest in the Upper Calcasieu River watershed and 0.3% within the Houston River watershed. Because the species of concern would likely move to adjacent forested areas with suitable habitat, the cumulative loss of forested area would be considered minor.

Table 5.3-1 Summary of Potential Cumulative Impacts on Forest Habitat

	Forested Area Affected (acres)
Connected Action	
LCCE Gasification	70
Construction parking	0
Equipment laydown and methanol/sulfuric acid storage ¹	40
Linears for natural gas, potable water, transmission, sulfuric acid, and methanol	0
Raw water pipeline	2.5
Hydrogen pipeline	2.5
Subtotal	115
Proposed Project	
CO ₂ Capture and Compression ²	-
CO ₂ pipeline	10.2
Research MVA	0
Subtotal	10.2
Foreseeable Future Projects	
Lake Charles Port Facility Expansion	70
Sasol	45
Trunkline	64
USACE permits pending Calcasieu Parish	54.2
Subtotal	233.2
Total	358.4

Notes:

¹ Estimated as final location is unknown at this time.

5.3.3 Traffic and Transportation

Multiple projects could result in cumulative impacts on traffic conditions if they utilize the same local road network at the same time. Impacts could also occur if the same exit from an Interstate highway is used with a traffic signal on the secondary road that could result in traffic backing up onto the Interstate travel lane. It is assumed that the impact on the free-flowing traffic on the Interstate would be negligible.

The proposed project and connected action would not contribute to long-term significant cumulative impacts on transportation and traffic. A review of the reasonably foreseeable projects in the area (see Table 5.1-1 and Figure 5.1-1) indicated that only the proposed Sasol Westlake Gas-to-Liquids project, which is located approximately 3.75 miles north of the LCCE Gasification Plant site, would have the potential to simultaneously use the same roads as the gasification project. Due to the proximity of both projects to Interstate 10 and the distance between access points to enter or exit Interstate 10, it is expected that the majority of traffic would use the most direct route to reach each site. The most direct route for a majority of traffic traveling to the LCCE Gasification Plant site would be to travel on Interstate 10 and exit on Exit 25 to Highway 108 and then travel south to Bayou D'Inde Road. The most direct route for a majority of traffic traveling to the Sasol project site would be to travel on Interstate 10 and then

exit onto the interchange with Interstate 210 at Exit 26, which is approximately 3 miles east of Interstate 10 Exit 25. It is expected that the traffic generated by the Sasol project and LCCE Gasification Plant would use different Interstate 10 exits and different local roadways to access the projects; therefore, the potential for cumulative impacts on traffic and transportation from the combined projects would be negligible. The other reasonably foreseeable Louisiana projects listed in Table 5.1-1 would use different Interstate 10 exits and local road networks. Therefore, adoption of the proposed action would have negligible incremental cumulative effects on local and regional traffic and transportation resources.

Cumulative impacts from noise generated by trucks during construction could occur if the same road networks were utilized by different projects at the same time. As Figure 5.1-1 shows, except for Interstate 10, the Sasol and Trunkline projects would use different roadways than the proposed project or connected action. Consequently, there would be a negligible potential for cumulative impacts caused by noise during construction or operation of the proposed project and connected action.

5.3.4 Socioeconomics

Construction and operation of the proposed LCCE Gasification and Lake Charles CCS Plant are expected to have a positive impact on the economies of communities within the Greater Lake Charles area. The approximately \$2 billion (2010 dollars) project construction cost and its subsequent annual operation expenditures would inject substantial income into the southern Louisiana regional economy. In addition to the direct expenditures and employment impacts, the proposed project would also generate additional indirect and induced economic benefits from the increased economic activity. A portion of the wages paid to construction workers is anticipated to be spent locally, particularly since a large majority of these workers are expected to be recruited from the local labor force. Furthermore, increased revenues from material purchases and construction contracts would inject funds into the regional economy.

The execution of multiple concurrent projects could result in competition for short-term skilled and unskilled labor, as well as facilities for lodging. Incremental beneficial short-term and long-term impacts would result from increased employment opportunities, local spending, and related sales/property tax revenue. However, the projects identified in Table 5.1-2 may not occur concurrently and may actually overlap in their completion, increasing the longevity of the beneficial effects and ameliorating negative cumulative effects.

As a stand-alone project, the Hastings MVA research program will have minimal to no socioeconomic impacts. However, the proposed research MVA program could have positive impacts of helping to ensure the long-term economic and financial viability of CO₂ capture activities by confirming storage of CO₂ injected during EOR operations. Information collected during the research MVA program would provide additional, unique data on the effectiveness of CO₂ sequestration in EOR operations. The data could help firmly establish the commercial viability of CO₂ capture and sequestration technologies throughout the Gulf Coast region. The increase in onshore Gulf Coast oil production is not likely to be enough to cause local oil prices to decline. Introduction of infrastructure for CO₂-based EOR in the onshore Gulf Coast could incrementally increase the region's projected oil reserves and increase the value of existing oil fields, some now considered depleted, as well as increase the capture of CO₂. The additional oil production resulting from investments in EOR infrastructure would generate jobs and additional

local, state, and nationwide new net tax revenues (e.g., sales/property tax revenue and oil production tax revenue).

This page left blank intentionally.

6. Applicable Regulatory Requirements and Permits

This chapter includes a description of the relevant federal laws, regulations, and Executive Orders; state regulations and permitting requirements; and local regulations and permitting requirements that were considered during the development of this EIS. Laws, regulations, ordinances, and permitting requirements are all enforceable on the project and, therefore, impose requirements on the project developer. Executive Orders instead impose requirements on the responsible federal agency, or DOE for this project.

6.1 Federal Laws and Regulations

The following federal laws and regulations are presented in alphabetical order, not in terms of importance.

Bald and Golden Eagle Protection Act (16 USC 668-668d, 54 Stat 250)

The Bald Eagle Protection Act of 1940 protects bald eagles and golden eagles, their nests, and their eggs, by prohibiting the capturing, killing, taking, or transporting of such birds. The 1978 amendment authorizes the Secretary of the Interior to issue a permit to take such birds' nests if they interfere with resource development.

Clean Air Act, as amended (42 U.S.C. §7401 et seq.)

The Clean Air Act (CAA) establishes regulations to protect air quality and authorizes individual states to manage permits. The CAA and amendments required the EPA to implement regulations for: (1) the national ambient air quality standards (NAAQS) as necessary to protect the public health, with an adequate margin of safety, from any known or anticipated adverse effects of a regulated pollutant (40 CFR 50 and 51); (2) national standards of performance for new or modified stationary sources of atmospheric pollutants (40 CFR 60); (3) specific emission increases to be evaluated so as to prevent a significant deterioration in air quality (40 CFR 52); (4) specific standards for releases of hazardous air pollutants (40 CFR 61, 63, and 68); and issuing operating permits (40 CFR 70). These standards are implemented through plans developed by each state with EPA approval. The CAA requires sources to meet air quality standards and obtain permits.

In addition, and in parallel with NEPA, the CAA requires federal actions to consider emissions of a project sponsored, licensed, funded, or approved by a federal agency under the General Conformity Rule (40 CFR 51 and 93) if they are not already covered by a permit, such as construction emissions. The General Conformity Rule implements provisions in Section 176(c) (42 U.S.C. §7506) of the CAA that prohibit federal agencies from taking actions that may cause or contribute to violations of the NAAQS or interfere in the purpose of a state implementation plan (SIP), transportation improvement program (TIP), or federal implementation plan (FIP) in an area working to attain or maintain the standards.

Under the authority of section 112(r) of the CAA, the Chemical Accident Prevention Provisions require facilities that produce, handle, process, distribute, or store certain chemicals to develop a Risk Management Program, prepare a Risk Management Plan (RMP), and submit the RMP to the EPA. The rule requires covered facilities to develop and implement safe business practices to identify hazards and manage risks. The facility must analyze worst-case releases,

document a five-year history of serious accidents, coordinate with local emergency responders, and file a risk management plan with the EPA. If an accidental chemical release could affect the public, the facility must analyze more probable scenarios and develop and implement a prevention program that includes identification of hazards, written operating procedures, training, maintenance, and accident investigation. An emergency response program must be implemented if employees respond to accidental releases.

Clean Water Act, as amended (33 U.S.C. §1251 et seq.)

The Clean Water Act (CWA) requires the EPA to set national effluent limitations and water quality standards and establishes a regulatory program for enforcement. Specifically, Section 402(a) of the CWA establishes water-quality standards for contaminants in surface waters. The CWA requires that a National Pollutant Discharge Elimination System (NPDES) permit be obtained before discharging any point source pollutant into U.S. waters (40 CFR 122).

Section 404 of the Clean Water Act specifically establishes the program that regulates the discharge of dredged and fill material into waters of the United States, including wetlands. Activities in waters of the United States that are regulated under this program include fills for development, water resource projects (such as dams and levees), infrastructure development (such as highways and airports), and conversion of wetlands to uplands for farming and forestry. Applicants requesting a Section 404 permit for any activity that may result in a discharge into waters of the U.S. must first obtain a State 401 water quality certification. In Louisiana, this certification is required by the Louisiana Department of Natural Resources (LADNR); in Texas, the regulatory authority is the Texas Commission on Environmental Quality (TCEQ).

Comprehensive Environmental Response, Compensation, and Liability Act (CERCLA), as amended by the Superfund Amendments and Reauthorization Act of 1986 (SARA)

CERCLA authorizes the federal government to hold a party liable for the release and cleanup of a hazardous waste. If a responsible party cannot be identified, CERCLA provides for funds to clean up the site.

Coastal Wetlands Planning, Protection and Restoration Act (16 USC 3951-3958)

The Coastal Wetlands Planning, Protection and Restoration Act promotes the conservation and management of wetlands by providing funding for the protection, restoration, and construction of wetlands. The Act authorizes the USFWS to participate in the development of a wetlands restoration program in Louisiana.

Emergency Planning and Community Right-to-Know Act of 1986 (42 U.S.C. §11001 et seq.) (also known as Superfund Amendments and Reauthorization Act [SARA] Title III)

The Emergency Planning and Community Right-to-Know Act of 1986, which is the major amendment to the Comprehensive Environmental Response, Compensation, and Liability Act (CERCLA) (42 U.S.C. §9601), establishes the requirements for federal, state, and local governments; Indian tribes; and industry regarding emergency planning and “Community Right-to-Know” reporting on hazardous and toxic chemicals. The “Community Right-to-Know” provisions increase the public’s knowledge and access to information on chemicals at individual facilities, their uses, and releases into the environment (40 CFR 355 and 370). States and communities working with facilities can use the information to improve chemical safety and

protect public health and the environment. This Act requires emergency planning and notice to communities and government agencies concerning the presence and release of specific chemicals.

Endangered Species Act of 1973, as amended (16 U.S.C. § 1531 et seq.)

The Endangered Species Act was enacted to prevent the further decline of endangered and threatened species and to restore those species and their critical habitats. Section 7 of the Act requires consultation with either or both the USFWS of the U.S. Department of the Interior and the National Marine Fisheries Service of the U.S. Department of Commerce to determine whether endangered and threatened species or their critical habitats are known to be in the vicinity of the proposed action and assessment of potential impacts.

Fish and Wildlife Conservation Act (16 USC 2901-2911)

The Fish and Wildlife Conservation Act promotes state conservation plans for non-game fish and wildlife species by recognizing the ecological, educational, economic, and scientific value they provide. The Act allows federal agencies to assist in the development of the plans by sharing information, equipment, and personnel with the states.

Flood Control Act of 1944 (16 USC 460d)

The Flood Control Act of 1944 authorizes various USACE water development projects for flood control and watershed management. The Act was intended to limit projects to those which benefit navigation and create minimal impact on other river uses.

Hazardous Materials Transportation Act (49 U.S.C. § 1801 et seq.)

The Hazardous Materials Transportation Act regulates the transportation of hazardous materials (including radioactive material) in and between states. According to the Act, states may regulate the transport of hazardous materials as long as they are consistent with the Act or the U.S. Department of Transportation regulations provided in 49 CFR 171-177.

Magnuson-Stevens Fishery Conservation and Management Act (16 USC § 1801 et seq.)

The Magnuson-Stevens Fishery Conservation and Management Act, as amended through October 1996, protects fish species and designated essential fish habitat. The Act requires consultation with the National Marine Fisheries Service to determine whether essential fish habitats are known to be in the vicinity of the proposed action and assessment of potential impacts. The Act provides the federal government with exclusive rights over marine fisheries.

Migratory Bird Treaty Act of 1918 (16 USC 703-712, ch 128)

The Migratory Bird Treaty Act of 1918 provides for the protection of certain species of migratory birds as defined in the Act. It is unlawful to capture, kill, take, or transport across state or district boundaries any such bird, its nest, or its eggs.

National Environmental Policy Act of 1969, as amended (42 U.S.C. §4321 et seq.)

The National Environmental Policy Act (NEPA) establishes national environmental policy and goals for the protection, maintenance, and enhancement of the environment to ensure for all Americans a safe, healthful, productive, and aesthetically and culturally pleasing environment. The Act provides a process for implementing these specific goals within the federal agencies responsible for the action.

National Historic Preservation Act of 1966, as amended (16 U.S.C. § 470 et seq.)

The National Historic Preservation Act (NHPA) was enacted to create a national historic preservation program, including the National Register of Historic Places and the Advisory Council on Historic Preservation (ACHP). Section 106 of the NHPA requires federal agencies to take into account the effects of their undertakings on historic properties. The ACHP regulations implementing Section 106, found in 36 CFR Part 800, were revised and became effective on August 5, 2004. These regulations call for public involvement in the Section 106 consultation process, including Indian tribes and other interested members of the public, as applicable.

Noise Control Act of 1972, as amended (42 U.S.C. § 4901 et seq.)

The Noise Control Act delegates the responsibility of noise control to state and local governments. Commercial facilities are required to comply with federal, interstate, state, and local requirements regarding noise control.

Occupational Safety and Health Act of 1970, as amended (29 U.S.C. § 651 et seq.)

The Occupational Safety and Health Act established standards to enhance safe and healthy working conditions in places of employment throughout the United States. The Act is administered and enforced by the Occupational Safety and Health Administration (OSHA), a U.S. Department of Labor agency. The identification, classification, and regulation of potential occupational carcinogens are found in 29 CFR 1910.101, while the standards pertaining to hazardous materials are listed in 29 CFR 1910.120. The OSHA regulates mitigation requirements and mandates proper training and equipment for workers.

The OSHA Process Safety Management (PSM) of Highly Hazardous Chemicals standard (29 CFR 1910.119) contains requirements for the management of hazards associated with processes using highly hazardous chemicals. This rule is similar (and in some cases identical) to the CAA 112(r) rule. It requires covered facilities to identify hazards and manage risks, but from the standpoint of protecting employees.

Resource Conservation and Recovery Act, as amended (42 U.S.C. §6901 et seq.)

The Resource Conservation and Recovery Act (RCRA) required the EPA to define and identify hazardous waste; establish standards for its transportation, treatment, storage, and disposal; and require permits for persons engaged in hazardous waste activities. RCRA required the EPA to develop regulations for managing hazardous wastes (40 CFR 261) and preventing certain wastes from being disposed on land (40 CFR 273, §279). RCRA (42 U.S.C. §6926) allows states to establish and administer these permit programs with EPA approval. The EPA has delegated regulatory jurisdiction to Louisiana and Texas under the Louisiana Department of Environmental Quality (LDEQ), the TCEQ, and the RRC. The EPA, however, retains its authority under RCRA sections 3007, 3008, 3013, and 7003, which include, among others, authority to: (1) conduct inspections, and require monitoring, tests, analyses or reports; (2) enforce RCRA requirements and suspend or revoke permits; and (3) take enforcement actions regardless of whether the state has taken its own actions.

Rivers and Harbors Act of 1899 (33 USC 403)

The Rivers and Harbors Act of 1899 prohibits excavation or fill within navigable waters without authorization. Under Section 10, projects impacting navigable rivers and harbors require a USACE Section 10 permit, which triggers the requirement for a CWA Section 401 certificate.

Safe Drinking Water Act, as amended (42 U.S.C. § 300f et seq.)

The Safe Drinking Water Act was enacted to protect the quality of public water supplies and sources of drinking water. Other programs established by the Safe Drinking Water Act include the Sole Source Aquifer Program, the Wellhead Protection Program, and the Underground Injection Control Program. In addition, the Act provides underground sources of drinking water with protection from contaminated releases and spills (e.g., requiring the implementation of a Spill Prevention Control and Countermeasure Plan).

United States Department of Agriculture, Natural Resources Conservation Service - Farmland Protection Policy Act

Projects are subject to Farmland Protection Policy Act (FPPA) requirements if they may irreversibly convert farmland (directly or indirectly) to nonagricultural use and are completed by a federal agency or with assistance from a federal agency.

6.2 Applicable Executive Orders

The following Executive Orders are presented in numerical order, not in terms of importance.

Executive Order 11514 (Protection and Enhancement of Environmental Quality)

Directs federal agencies to continuously monitor and control activities to protect and enhance the quality of the environment. The Order also requires agencies to develop procedures to ensure the fullest practical provision of timely public information and the understanding of federal plans and programs with potential environmental impacts, and to obtain the views of interested parties. DOE promulgated regulations (10 CFR 1027) and issued DOE Order 451.1b, *National Environmental Policy Act Compliance Program* to ensure compliance with this Executive Order. Because the proposed action is a federal action that requires NEPA analysis, DOE must comply with Order 451.1b.

Executive Order 11988 (Floodplain Management)

Directs federal agencies to establish procedures to ensure that the potential effects of flood hazards and floodplain management are considered for any action undertaken in a floodplain. Agencies are to avoid impacts on floodplains to the extent practicable. DOE regulation 10 CFR 1022 establishes procedures for compliance with this Executive Order. Where no practical alternative exists to development within a floodplain or wetland, DOE is required to prepare a floodplain and wetlands assessment discussing the effects on the floodplain and wetlands, and consideration of alternatives. (A statement of findings from the assessment will be incorporated into the Final EIS.) In addition, these regulations require DOE to design or modify its actions to minimize potential damage in floodplains or harm to wetlands. DOE is also required to provide opportunity for public review of any plans or proposals for actions in floodplains and new construction in wetlands.

Executive Order 11990 (Protection of Wetlands)

Requires federal agencies to avoid short- and long-term impacts on wetlands if a practical alternative exists. DOE regulation 10 CFR 1022 establishes procedures for compliance with this Executive Order. Where no practical alternative exists to development in a floodplain or wetland, DOE is required to prepare a floodplain and wetlands assessment discussing the effects on the floodplain and wetlands, and consideration of alternatives. (A statement of findings from the assessment will be incorporated into the Final EIS.) In addition, these regulations require

DOE to design or modify its actions to minimize potential damage in floodplains or harm to wetlands. DOE is also required to provide opportunity for public review of any plans or proposals for actions in floodplains and new construction in wetlands.

Executive Order 12856 (Right-to-Know Laws and Pollution Prevention Requirements)

Directs federal agencies to reduce and report toxic chemicals entering any waste stream, improve emergency planning, response, and accident notification, and encourage the use of clean technologies and testing of innovative prevention technologies. In addition, this Order states that federal agencies are persons for purposes of the Emergency Planning and Community Right-to-Know Act, which requires agencies to meet the requirements of the Act.

Executive Order 12898 (Environmental Justice)

Requires federal agencies to address environmental justice in minority and low-income populations (59 FR 7629) and directs federal agencies to identify and address, as appropriate, disproportionately high and adverse health or environmental effects of their programs, policies, and activities on minority and low-income populations.

Executive Order 13045 (Protection of Children from Environmental Health Risks and Safety Risks)

Requires federal agencies to make it a high priority to identify and assess environmental health risks and safety risks that may disproportionately affect children and ensure that policies, programs, and standards address disproportionate risks to children that result from environmental health and safety risks.

Executive Order 13175 (Consultation and Coordination with Indian Tribal Governments)

Directs federal agencies to (1) establish regular and meaningful consultation and collaboration with tribal governments in the development of federal policies that have tribal implications, (2) strengthen United States government-tribal government relationships, and (3) reduce the imposition of unfunded mandates on tribal governments.

Executive Order 13186 (Migratory Birds)

Requires federal agencies to avoid or minimize the negative impacts of their actions on migratory birds and to take active steps to protect birds and their habitats.

6.3 State Laws, Regulations, and Agreements

Certain environmental requirements, including those discussed earlier, have been delegated to state authorities for implementation, enforcement, or oversight. Tables 6.3-1 and 6.3-2 provide a list of State of Louisiana and State of Texas laws, regulations, and agreements that are relevant to the Applicant's proposed project. The following state laws, regulations, and agreements are presented in alphabetical order, not in terms of importance.

Table 6.3-1 Applicable Louisiana State Laws, Regulations, and Agreements

Responsible Agency	Citation	Regulated Activity
LDEQ	LAC Title 33 Part III	Air Quality (ambient air quality standards, control of emissions, emissions standards, permits, procedures, fees, etc.)
LDEQ	LAC Title 33 Part IX	Water Quality (water quality standards, monitoring and surveillance, permits, enforcement, etc.)
LDEQ	LAC Title 33 Part VII	Transportation, storage, and disposal of solid and hazardous waste
LDNR/State Highway Right-of-Way/Dept. of Health and Human Resources	La R.S. 382, Section 385	Proposed discharge of industrial waste, sewage, septic tank effluent, or any other noxious or harmful matter, whether soils, liquid, or gas, into or across ditches of state rights-of-way requires review and permit approvals.
LDNR, Department of Wildlife and Fisheries	Title 56, R.S. 56:1901 - 07	Clearances for ecological areas of concern, bald cypress swamps, and natural undisturbed bottomland forests; clearances on wildlife species; threatened and endangered species conservation
Louisiana Department of Transportation and Development	R.S. 48:344.	Establishes rules and requirements for access to state roadways to ensure safe and orderly movement of vehicular traffic entering and leaving roadways
Louisiana Office of Cultural Development, Division of Archaeology	R.S. 41: 1601-1615	Establishes rules and regulations pertaining to shipwrecks, prehistoric and historic archaeological sites, maintaining archaeological site files, undertaking an outreach program, and curating materials from state lands and donations
Louisiana Historic Cemetery Preservation Act	R.S. 25: 931-943	Permits for activities at an abandoned cemetery that could potentially disturb the graves, tombs, headstones, fencing or other elements of the cemetery
Louisiana State Land Office		Pipeline right-of-way grant
Louisiana State and Local Coastal Resources Management Act	R.S. 49: 214.21 et seq.	Coastal Consistency Determination. Proposed activity in the Coastal Zone must be in accordance with guidelines established in the Louisiana Coastal Resources Program
Louisiana Scenic Rivers Act	Louisiana R.S. 56:1841 through 56:1849	Scenic River Permits are required for all activities on or near System Rivers that may detrimentally impact the ecological integrity, scenic beauty, or wilderness qualities of those rivers
Louisiana Unmarked Human Burial Sites Preservation Act	R.S. 8: 671-681	Protection and excavation of cemeteries and burials when they are encountered
State of Louisiana Sabine River Authority Diversion Canal Office	Louisiana R.S. 38:2321, et. seq.	Right-of-Way Crossing Permit

Key:

- LDEQ = Louisiana Department of Environmental Quality.
- LDNR = Louisiana Department of Natural Resources.

Table 6.3-2 Applicable Texas State Laws, Regulations, and Agreements

Law/Regulation/Agreement	Citation	Requirements
RRC	Title 16 TAC Part 1, Chapter 3	Production of oil and gas, including: injection of fluids into the subsurface for the purpose of enhanced oil recovery, protection of freshwater zones, casing and cementing requirements, plugging and abandonment requirements, gas production and handling, and oil and gas production pipelines, tank batteries, and discharge of surface waste use of existing well bores.
RRC	Title 16 TAC Part 1 Chapter 5, Subchapter C	Regulations for voluntary certification of geologic storage of anthropogenic CO ₂ incidental to enhanced oil recovery
RRC	TAC Title 16, Chapter 3, Rule 3.8; RRC Rule 8	Discharge of surface waste
Texas Department of Licensing and Regulation	Title 16 TAC §76.702	Monitor well drilling, completion and abandonment - responsibilities of the licensee and landowner
Texas Department of Licensing and Regulation	Title 16 TAC §76.1004	Technical Requirements—Standards for Capping and Plugging of Wells and Plugging Wells that Penetrate Undesirable Water or Constituent Zones
THC - Cultural Resources, Texas Administrative Code	Title 13 (all parts)	Publicly funded or licensed projects must undergo a review by staff members to determine whether any properties in the project area meet National Register criteria. If so, the federal agency must consult with the THC on any effect the project would have on those historic properties

Key:

- RRC = Railroad Commission of Texas.
- THC = Texas Historical Commission.

6.4 Permits and Approval Status

The federal, state and local permits, licenses, and other entitlements that must be obtained to implement the Applicant’s proposed project are included in Table 6.4-1. In addition, if the permit, license, or other approval has been obtained, it is noted in the table.

Table 6.4-1 Required Federal and State Permits and Approval Status

Permit/License/Approval	Principal Regulatory Citation	Lead Agency	When Required	Required for		Applicable/Potentially Applicable				Comments/Approval Status
				Construction	Operation	CO ₂ Capture and Compression	CO ₂ Pipeline	CO ₂ Sequestration and MVA	LCCE Gasification (connected action)	
U.S. Army Corps of Engineers Section 404 Permit	Clean Water Act, Section 404, and Rivers and Harbors Act of 1899, Section 10	USACE	Impacts of construction on wetlands or navigable waters	✓		✓	✓		✓	<p>Lake Charles Harbor & Terminal District: Consent No. DACW29-9-08 (May 30, 2008) and MVN-1998-03311-WY (August 18, 2008) - clearing, grubbing, and grading an area, depositing fill material and constructing a bulkhead for a coke gasification plant, within Calcasieu River and Pass Channel Improvement Project.</p> <p>CO₂ Pipeline: NWP 12 permit to impact waters of the U.S.</p>
Consultation on Presence of Rare, Threatened, or Endangered Species or Habitats	Endangered Species Act	LDWF	Potential impacts on listed species; implemented through USACE permit review	✓		✓	✓		✓	<p>LCCE Gasification and CO₂ Capture and Compression: Project ID 09052801 (May 28, 2009). Notice of no impacts on rare, threatened, or endangered species or critical habitats.</p>
Consultation on presence of and effect on historic properties within the area of potential effect for the Proposed Action	Section 106 of National Historic Preservation Act of 1966 (36 CFR Part 800)	DOE THC	Completion of consultation process prior to signing of the Record of Decision	✓		✓	✓		✓	<p>DOE initiated the Section 106 consultation process for the Proposed Action.</p> <p>LCCE Gasification and CO₂ Capture and Compression: As part of a separate action by Leucadia that did not require compliance with Section 106, the Louisiana SHPO concurred with the cultural resources consultant's findings that there were no historic properties at the LCCE Gasification and CO₂ Capture and Compression facilities location.</p> <p>CO₂ Sequestration and MVA: As part of the current Proposed Action and in support of the Section 106 process, the</p>

Table 6.4-1 Required Federal and State Permits and Approval Status

Permit/License/Approval	Principal Regulatory Citation	Lead Agency	When Required	Required for		Applicable/Potentially Applicable				Comments/Approval Status
				Construction	Operation	CO ₂ Capture and Compression	CO ₂ Pipeline	CO ₂ Sequestration and MVA	LCCE Gasification (connected action)	
										Texas SHPO concurred with the cultural resources consultant's findings that there were no historic properties at the CO ₂ Sequestration and MVA location. AI No. 160213, Activity No. PER 2009001. LCCE notice of no objection to construction received 6/26/09.
NPDES Industrial Wastewater Discharge Permit	40 CFR 122 LAC 33.IX. 2501 et seq.	LDEQ	Industrial discharges into surface waters of the U.S., including storm water		✓	✓			✓	LCCE Gasification and CO₂ Capture and Compression: LA0124541 and AI No. 160213 to discharge from end of Bayou D'Inde Road in Sulphur, Calcasieu Parish, in accordance with effluent limitation, monitoring requirements, and other conditions set forth.
NPDES Construction Stormwater General Permit	40 CFR 122 LAC 33.IX. 2511 and 2515	LDEQ RRC	Discharge of storm water for construction activity disturbing more than 1 acre of soil	✓		✓	✓		✓	Notification prior to construction.
NPDES Multi-Sector Stormwater General Permit	40 CFR 122 LAC 33.IX.2515	LDEQ	Discharges of storm water to surface waters of the U.S. associated with operation of industrial activities.		✓	✓			✓	Notification prior to startup and operation.
Air Permit to Construct (PSD) and Operate (Title V)	40 CFR 52 and 70 LAC 33: Part III	LDEQ	Prior to starting construction and operation	✓	✓	✓			✓	LCCE Gasification and Co2 Capture and Compression: PSD-LA-742 and 0520-00411-V0 to construct and operate a new facility pursuant to the prevention of significant deterioration regulations and state preconstruction and Part 70 operating permit, effective June 29, 2012.
Highway/Road Encroachment Permit	La. R.S. 38:111 through 38:225	LA DOTD and CPPJ	To cross federal/state highways/roads for use and occupancy of rights-of-way				✓			CO₂ Pipeline: State of Louisiana, Sabine River Authority, Diversion Canal Office Right-of-Way Crossing Permit

Table 6.4-1 Required Federal and State Permits and Approval Status

Permit/License/Approval	Principal Regulatory Citation	Lead Agency	When Required	Required for		Applicable/Potentially Applicable			Comments/Approval Status
				Construction	Operation	CO ₂ Capture and Compression	CO ₂ Pipeline	CO ₂ Sequestration and MVA	
Pipeline Construction and Operating Permit	LAC: Title 43	LDNR, Pipeline Division					✓		(TBD)
Discharges of Hydrostatic Test Waters	LAC 33.IX. 2501 et seq.	LDEQ	Prior to discharge				✓		To be obtained for all pipelines
Short-Term Construction Access	LAC 70.I. 1501 et seq.	LA DOTD		✓		✓		✓	potentially required for use of the construction parking area
Oversize/Overweight Permit	Add LA cite Section 623.018	LA DOTD TxDOT and Brazoria County	To operate a vehicle that exceeds the legal size or weight on state highways	✓		✓	✓	✓	
Calcasieu Parish Flood Zone Management Permit	Ordinance No. 5906	CPPJ		✓		✓	✓	✓	Floodplain Development Permit Waiver obtained for LCCE Gasification Plant in letter from Tim Conner, Calcasieu Parish Police Jury Division of Engineering and Public Works, to Martin Benoit, P.E., Levingston Group, LLC. February 14, 2012, obtained for LCCE Gasification.

Key:

- CPPJ = Calcasieu Parish Police Jury
- DOE = U.S. Department of Energy
- LA DOTD = Louisiana Department of Transportation and Development
- LDEQ = Louisiana Department of Environmental Quality
- LDNR = Louisiana Department of Natural Resources
- NPDES = National Pollutant Discharge Elimination System
- RRC = Railroad Commission of Texas
- TxDOT = Texas Department of Transportation
- THC = Texas Historical Commission
- USACE = U.S. Army Corps of Engineers
- USFWS = U.S. Fish and Wildlife Service

This page left blank intentionally

7. Irreversible and Irrecoverable Commitment of Resources

A resource commitment is considered irreversible when impacts from its use limit future use options and the change cannot be reversed, reclaimed, or repaired. Irreversible commitments generally occur to nonrenewable resources such as minerals or cultural resources, and to those resources that are renewable only over long time spans, such as soil productivity.

A resource commitment is considered irretrievable when the used or consumed resource is neither renewable nor recoverable for use by future generations until reclamation is successfully applied. Irretrievable commitments generally apply to the loss of production, harvest, or natural resources and are not necessarily irreversible.

The principal commitment of resources is the 70-acre parcel of land that would be occupied by the LCCE Gasification Plant. The Lake Charles CCS project would also be located within this 70-acre parcel. Although not all of the 70-acre parcel would be developed, it is likely that the entire site would be unavailable for other uses. Similarly, the land required for the linear facilities and their newly developed permanent ROWs, 147.81 acres, would be restricted from other uses. However, when the operational life of the gasification facility is over and the plant and linear facilities have been decommissioned and reclaimed, the land would be available for other uses. Therefore, land use represents an irretrievable commitment of resources during the lifespan of the project.

The land areas required for the gasification facility and linear facilities would be cleared, graded, and filled, as needed, during construction of the project; no additional land would be disturbed or used for the CO₂ capture and compression facilities. These activities would result in additional irreversible and irretrievable impacts. When construction activities begin, the removal of existing vegetation and soils would cause the mortality of some wildlife, such as slow-moving and burrow-dwelling species. In addition, the soil and vegetation habitats would be lost for future use by wildlife until the facilities were decommissioned and the land reclaimed. The direct mortality of wildlife would be an irreversible impact and the loss of habitat would be an irretrievable impact. The loss of soil would primarily be considered an irretrievable impact but not irreversible, because reclamation would most likely include active replacement of the topsoil rather than passive reliance on natural processes to replace the topsoil.

Disturbance of a portion of archaeological site 16CU29 during construction of the gasification plant and archaeological site 16CU73 during construction of the CO₂ pipeline would result in irreversible impacts on those resources. Both sites were determined to be not eligible for listing in the NRHP (see Section 3.7). Clearing and grading actions also could pose a risk to cultural resources that have not yet been identified on areas that will be disturbed, including the construction equipment laydown area, the linears for the water supply and hydrogen pipelines, and the CO₂ pipeline corridor. Disturbances to these resources would be considered irreversible.

Approximately 12 MGD of raw water would be withdrawn from the Sabine River and used throughout the LCCE Gasification Plant process train for cooling water, service water, and fire

water (see Section 2.3). The CO₂ capture and compression facilities would use about 10% of this raw water supply (see Section 4.4.3). Approximately 700,000 gallons of water would be used for hydrostatic testing of the pipelines associated with the LCCE Gasification Plant, including the methanol, sulfuric acid, natural gas, potable water, raw water, and hydrogen pipelines (see Section 2.4). In addition, approximately 20,000 GPD of potable water would be supplied by the City of Sulphur during construction and operation of the facility. This water would be discharged through a septic system. The use of water at the plant would result in an irretrievable commitment of water resources because it would not be directly discharged to surface water or groundwater, and would be unavailable for future use by the local area or downstream users.

Material and energy resources committed to the construction and operation of the LCCE Gasification Plant, including the CO₂ capture and compression facilities and the linear facilities, would include construction materials (e.g., steel, concrete, wood), electricity, and fuel (e.g., petcoke, natural gas, diesel, gasoline). All energy used during construction and operation would result in an irreversible commitment of this resource. During operation, the plant and CO₂ capture and compression facility would use process chemicals, which would be irreversibly committed.

Injection of CO₂ into the subsurface at the Hastings oil field would irreversibly commit portions of the Frio formation and the overlying Anahuac formation to CO₂ storage. These formations within the injection zone would lose their ability to serve any other function.

Construction and operation of the project would require the commitment of human resources that would not be available for other activities during the commitment period. This would be an irretrievable commitment of resources.

Construction and operation of the project would require the commitment of fiscal resources by Leucadia, Denbury, their investors and lenders, and DOE. The fiscal investment would be an irreversible commitment.

7.1 Relationship Between Short-term Uses of the Environment and Long-term Productivity

Short-term uses of the environment would primarily be associated with construction activities as described previously. For example, these would include the use of aesthetic, air, wetlands, and transportation resources, as well as the short-term use of land for construction staging areas. Aesthetic impacts affecting nearby residents could include the effects on viewsheds from land-clearing activities and increased noise levels at the plant area and linear facilities, although existing industrial facilities near the plant area might generate a greater visual impact. Aesthetics and air quality would both experience short-term impacts from fugitive dust emissions.

Wetlands along some of the proposed linear facilities sites would be disturbed or reduced by land-clearing activities. The disturbance of the wetlands, as well as general vegetation and wildlife habitat, would be considered short term because they would likely re-establish after the facilities were constructed. However, any reductions in wetland area could be long-term or even permanent. Short-term impacts would also include traffic diversions and disruptions during construction activities. The short-term impacts of land use would include land clearing for

staging areas and the equipment laydown yard. These areas would be reclaimed and restored at the end of the construction phase.

The project would enhance short-term productivity through direct, indirect, and induced creation of jobs during the 36-month construction period, including a total of 900 jobs at the plant area during the peak construction period. The construction project would also inject substantial income into the regional economy. Operation of the LCCE Gasification Plant and CO₂ capture and compression facilities would also result in beneficial impacts on the economy, employment, and tax base within the greater Lake Charles area over its operational life as a result of the 187 new permanent jobs that would be created, as well as the indirect and induced jobs created as a result of these permanent positions (see Section 4.9).

In the long term, the LCCE Gasification Plant would support the DOE objective of demonstrating the next generation of technologies that will capture CO₂ emissions from industrial sources and either sequester or beneficially use them. These technologies for carbon capture and sequestration have significant potential to reduce CO₂ emissions and thereby mitigate global climate change while minimizing the economic impacts of the solution.

This page left blank intentionally.

8. References

Summary

- ATCO Noise Management (ATCO). 2012. *Lake Charles Carbon Capture & Sequestration (CCS) Project Environmental Noise Survey & Noise Impact Assessment*. Prepared for Leucadia Energy, LLC. March 7, 2012.
- Air Products and Chemicals, Inc. (APCI). 2011. *Environmental Assessment: Demonstration of CO₂ Capture and Sequestration of Steam Methane Reforming Process Gas Used for Large Scale Hydrogen Production, Final*. Prepared for the U.S. Department of Energy, National Energy Technology Laboratory.
- Breaux, Pam. 2012. Letter dated April 25, 2012, from Pam Breaux, State Historic Preservation Officer, Office of Cultural Development, Louisiana Department of Culture, Recreation & Tourism, Baton Rouge, Louisiana, to Joel Watkins, Cultural Resource Analyst, Office of Archaeological Research, Moundville, Alabama. RE: *Draft Report, La Division of Archaeology Report No. 22-4007, Phase I Cultural Resource Survey of the Proposed Lake Charles Pipeline Lateral Project located near Sulphur, Calcasieu Parish, Louisiana*.
- Bureau of Economic Geology. 1996. Physiographic Map of Texas 1996: Information Sheet. Available online at: <http://www.lib.utexas.edu/geo/fieldguides/physiography.html>.
- CH2M Hill. 2010. *Environmental Information Volume, Pipeline Lateral, Lake Charles, Louisiana*. Prepared for Denbury Onshore, Inc.
- CH2M Hill. 2011. EIS Data Request, Pipeline Response. Prepared for the Lake Charles Pipeline Lateral Project.
- Chowdhury, A.H. and M.J. Turco. 2006. Chapter 2: Geology of the Gulf Coast Aquifer, Texas. In: *Aquifers of the Gulf Coast of Texas*. Texas Water Development Board, Report 365.
- Fayish, Pierina N. 2012. Letter dated August 15, 2012, from Pierina N. Fayish, NEPA Document Manager, National Energy Technical Laboratory, Department of Energy, Pittsburgh, Pennsylvania, to Pam Breaux, State Historic Preservation Officer, Office of Cultural Development, Louisiana Department of Culture, Recreation & Tourism, Baton Rouge, Louisiana. SUBJECT: *Initiation of Section 106 Consultation for Proposed Financial Assistance for the Lake Charles Carbon Capture and Sequestration (CCS) Project, Calcasieu Parish, Louisiana (and Brazoria County, Texas)*.

- Handly, Martin. 2009. Letter dated June 15, 2009, from Martin Handly, Principal Investigator, URS Corporation, Baton Rouge, Louisiana, to Mr. Donald W. Maley, Vice-President, Lake Charles Cogeneration, LLC, Houston, Texas. RE: *Field Assessment of Archaeological Site 16CU29, Lake Charles Gasification Facility, Lake Charles Cogeneration, LLC, Westlake, Calcasieu Parish, Louisiana.*
- Hutcheson, Scott. 2009. Letter dated June 26, 2009, from Scott Hutcheson, State Historic Preservation Officer, Office of Cultural Development, Department of Culture, Recreation and Tourism, State of Louisiana, Baton Rouge, Louisiana. RE: *Lake Charles Gasification Facility, Lake Charles Cogeneration LLC, Agency Interest No. 160213, Activity No. PER20090001, Lake Charles, Calcasieu Parish, LA.*
- Leucadia Energy, LLC (Leucadia). 2011. Personal communication, conference call L. Leib (Leucadia) and J. Christopher (E & E), regarding review of Chapter 2. November 22, 2011.
- _____. 2012a. Personal communication, telephone conversation between R. Collums (Leucadia) and J. Whitken (E & E) regarding acid gas removal process. October 2012.
- _____. 2012b. Email from P. Leonards ((Leucadia) to J. Whitken (E & E), regarding Action Items 81 and 109. August 30, 2012.
- _____. 2012c. Email response to Data Gap Request, R. Collums ((Leucadia) to J. Whitken (E & E). January 25, 2012.
- Lurgi GmbH (Lurgi). 2010. The Rectisol Process. Last updated on Nov. 1, 2010. Available at: http://www.lurgi.com/website/fileadmin/user_upload/1_PDF/1_Broshures_Flyer/englisch/0308e_Rectisol.pdf. Accessed on November 28, 2011.
- National Oceanic and Atmospheric Administration (NOAA). 2011. Coastal migratory species. Available online at: <http://ccma.nos.noaa.gov/products/biogeography/gom-efh/offshore.aspx#coastal>. Web site accessed on November 11, 2011.
- Sandeen, W. M. and J. B. Wesselman, 1973. Ground Water Resources of Brazoria County, Texas. Texas Water Development Board Report 163, 64 pages.
- Steve Walden Consulting and RDB Environmental Consulting. 2010. Environmental Information Volume Part 4: CO₂ Sequestration Monitoring, Verification, and Accounting. Hastings Oil Field, Texas. Prepared for Denbury Onshore, LLC.
- Texas Parks and Wildlife Department (TPWD). 2011. Wildlife Division, Wildlife Management Districts. Available online at: http://www.tpwd.state.tx.us/landwater/land/habitats/oak_prairie. Web site accessed on November 18, 2011.

- United States Army Corps of Engineers (USACE). 2009. Calcasieu River and Pass, Louisiana, Dredged Material Management Plan and Supplemental Environmental Impact Statement, Vol. 1. USACE New Orleans District, New Orleans, Louisiana.
- United States Census Bureau (USCB). 1993. 1990 Census of Housing; Detailed Housing Characteristics, Louisiana: Washington D.C. 337 p.
- _____. 2009. 2005-2009 American Community Survey 5-Year Estimates (City of Sulphur, LA; Calcasieu Parish, LA; State of Louisiana; City of Alvin, TX; City of Pearland, TX; Brazoria County, TX; Jefferson County, TX; and State of Texas). (http://factfinder.census.gov/home/saff/main.html?_lang=en. Accessed October 29, 2011.
- _____. 2010. Profile of General Population and Housing Characteristics: 2010 (City of Sulphur, LA; Calcasieu Parish, LA; State of Louisiana; City of Alvin, TX; City of Pearland, TX; Brazoria County, TX; Jefferson County, TX; and State of Texas). <http://factfinder2.census.gov/main.html>. Accessed October 29, 2011.
- United States Environmental Protection Agency (EPA). 2011. Enviromapper. On-line dataset of EPA-regulated facilities. Available online at <http://www.epa.gov/enviro/>. Web site accessed in September 2011.
- United States Fish and Wildlife Service (USFWS). 2011. Species by County Report: Calcasieu Parish, Louisiana. Environmental Conservation Online System. Available online at: http://ecos.fws.gov/tess_public/countySearch!speciesByCountyReport.action?fips=22019 Web site accessed on November 18, 2011.
- United States Geological Survey (USGS). 2011. Louisiana Water Science Center. Information on groundwater wells in Calcasieu Parish. Available at: <http://la.water.usgs.gov/WellsByParishMap.asp?Parish=Calcasieu>. Accessed on November 1, 2011.
- URS Corporation (URS). 2010. Lake Charles CCS Project: Environmental Information Volume Part I - CO₂ Capture and Compression Facilities at the Lake Charles Gasification Project. April 2010.
- Watkins, Joel H., and Eugene M. Futato. November 2011. *A Phase I Cultural Resources Survey of the Proposed Lake Charles Pipeline Lateral Project Located near Sulphur, Calcasieu parish, Louisiana* (Draft Report). Performed by The University of Alabama, Office of Archaeological Research, Moundville, Alabama. Performed for CH2M HILL, Atlanta, Georgia.

Chapter 1: Introduction

Air Products and Chemicals, Inc. (APCI). 2011. *Environmental Assessment: Demonstration of CO₂ Capture and Sequestration of Steam Methane Reforming Process Gas Used for Large Scale Hydrogen Production, Final*. Prepared for the U.S. Department of Energy, National Energy Technology Laboratory.

Denbury Onshore, LLC (Denbury). 2011a. *Pipeline Projects. Green Pipeline Project*. Last updated on August 9, 2011. Available at: <http://www.denbury.com/green-pipeline-project.html>. Accessed on November 28, 2011.

Handly, Martin. 2009. Letter dated June 15, 2009, from Martin Handly, Principal Investigator, URS Corporation, Baton Rouge, Louisiana, to Mr. Donald W. Maley, Vice-President, Lake Charles Cogeneration, LLC, Houston, Texas. RE: *Field Assessment of Archaeological Site 16CU29, Lake Charles Gasification Facility, Lake Charles Cogeneration, LLC, Westlake, Calcasieu Parish, Louisiana*.

Hutcheson, Scott. 2009. Letter dated June 26, 2009, from Scott Hutcheson, State Historic Preservation Officer, Office of Cultural Development, Department of Culture, Recreation and Tourism, State of Louisiana, Baton Rouge, Louisiana. RE: *Lake Charles Gasification Facility, Lake Charles Cogeneration LLC, Agency Interest No. 160213, Activity No. PER20090001, Lake Charles, Calcasieu Parish, LA*.

URS Corporation (URS). 2010. Lake Charles CCS Project: Environmental Information Volume Part I - CO₂ Capture and Compression Facilities at the Lake Charles Gasification Project. April 2010.

Chapter 2: Proposed Action and Alternatives

Air Products and Chemicals, Inc. (APCI). 2011. *Environmental Assessment: Demonstration of CO₂ Capture and Sequestration of Steam Methane Reforming Process Gas Used for Large Scale Hydrogen Production, Final*. Prepared for the U.S. Department of Energy, National Energy Technology Laboratory.

CH2M Hill. 2010. *Environmental Information Volume, Pipeline Lateral, Lake Charles, Louisiana*. Prepared for Denbury Onshore, Inc.

_____. 2011a. EIS Data Request, Pipeline Response. Prepared for the Lake Charles Pipeline Lateral Project.

_____. 2011b. Lake Charles Pipeline Lateral Project Pre-Construction Notification (PCN) for Nationwide Permit 12. Prepared for Denbury Onshore, LLC.

Denbury Onshore, LLC (Denbury). 2011a. *Pipeline Projects. Green Pipeline Project*. Last updated on August 9, 2011. Available at: <http://www.denbury.com/green-pipeline-project.html>. Accessed on November 28, 2011.

_____. 2011b. *Technology and Planning*. Last updated on August 3, 2011. Available at: <http://www.denbury.com/technology-and-planning.html>. Accessed on November 28, 2011.

_____. 2011c. *Health, Safety, and Environment. Carbon Capture and Storage (“CCS”) Solutions*. Last updated August 9, 2011. Available at: <http://www.denbury.com/ccs-solutions.html>. Accessed on November 28, 2011.

_____. 2012. Email from M. Blincow (Denbury) to J. Whitken (E & E) regarding AP EA Changes. October 4, 2012.

Electric Power Research Institute, Inc. (EPRI). 1999. Enhanced Oil Recovery Scoping Study. TR-113836. Prepared by Electric Power Research Institute, Inc., Palo Alto, California.

Leucadia Energy, LLC (Leucadia). 2011a. Response to Data Gap Request, email from C. Taub (Leucadia) to J. Whitken (E & E), Project Description, Question 2, Process Flow Diagram. November 3, 2011,

_____. 2011b. Response to Data Gap Request, email from C. Taub (Leucadia) to J. Whitken (E & E), Project Description, Question 4. November 7, 2011,

_____. 2011c. Response to Data Gap Request, email from R. Collums (Leucadia) to J. Whitken (E & E), Project Description, Question 8. November 7, 2011.

_____. 2011d. Personal communication, conference call L. Leib (Leucadia) and J. Christopher (E & E), regarding review of Chapter 2. November 22, 2011.

_____. 2011e. Email from L. Leib (Leucadia) to J. Whitken (E & E) regarding Water Balance and Outfall Information. November 23, 2011.

_____. 2011f. Response to Data Gap Request, Project Description, Question 7. From IT Questions Amended for LPDES Permit March 2009.

_____. 2011g. Email from L. Leib (Leucadia) to J. Whitken (E & E) regarding Fluxant. November 23, 2011.

_____. 2012a. Email response to Data Gap Request, R. Collums ((Leucadia) to J. Whitken (E & E). January 25, 2012.

_____. 2012b. Email from P. Leonards ((Leucadia) to J. Whitken (E & E), regarding Action Items 81 and 109. August 30, 2012.

_____. 2012c. Email from P. Leonards (Leucadia) to J. Whitken (E & E), regarding Action Items 7-11-12 responses. July 18, 2012.

- _____. 2012d. Personal communication, telephone conversation between R. Collums (Leucadia) and J. Whitken (E & E) regarding acid gas removal process. October 2012.
- Lurgi GmbH (Lurgi). 2010. The Rectisol Process. Last updated on Nov. 1, 2010. Available at: http://www.lurgi.com/website/fileadmin/user_upload/1_PDF/1_Broshures_Flyer/englisch/0308e_Rectisol.pdf. Accessed on November 28, 2011.
- Occupational Safety and Health Administration (OSHA). 2011. *OSHA Technical Manual*. Section IV. Chapter 2: Petroleum Refining Processes. Available at: http://www.osha.gov/dts/osta/otm/otm_iv/otm_iv_2.html. Accessed on November 28, 2011.
- Steve Walden Consulting and RDB Environmental Consulting. 2010. *Environmental Information Volume Part 4: CO₂ Sequestration Monitoring, Verification, and Accounting*. Hastings Oil Field, Texas. Prepared for Denbury Onshore, LLC
- Texas State Historical Association (TSHA). 2011a. *Handbook of Texas*. Hastings Oilfield. Available at: <http://www.tshaonline.org/handbook/online/articles/doh01>. Accessed on October 26, 2011.
- _____. 2011b. *Handbook of Texas*. Frio Deep-Seated Salt Dome Fields. Available at: <http://www.tshaonline.org/handbook/online/articles/doftg>.
- United States Department of Energy (DOE). 2002. Office of Fossil Energy, National Energy Technology Laboratory, Major Environmental Aspects of Gasification-Based Power Generation Technologies Final Report. December 2002.
- United States Environmental Protection Agency (EPA). 2010. Monitoring Plans for Geological Sequestration, Technical Support Document for Injection and Geological Sequestration of Carbon Dioxide, Proposed Rule for Mandatory Reporting of Greenhouse Gases, March 2010.

Chapter 3: Affected Environment

Section 3.1 (Introduction)

None.

Section 3.2 (Climate and Air Quality)

Federal Land Managers AQRV Workgroup (FLAG). 2010. U.S. Forest Service, National Park Service, and U.S. Fish and Wildlife Service. 2010. *Federal Land Managers' Air Quality Related Values Work Group (FLAG): Phase I Report*—revised (2010). Natural Resource Report NPS/NRPC/NRR—2010/232. National Park Service, Denver, Colorado.

- Louisiana Department of Environmental Quality (LDEQ). 2009. *2009 Louisiana Annual Network Assessment*, Air Quality Assessment Division, May 30, 2009. Available at: http://www.deq.louisiana.gov/portal/Portals/0/AirQualityAssessment/Analysis/Data/LAN_A%202009%20final%20with%20NCore.pdf. Accessed on January 10, 2013.
- National Climatic Data Center (NCDC). 2010a. *National Climatic Data Center Local Climatological Data Report for Lake Charles, Louisiana*. Federal Climate Complex, Asheville, North Carolina. Available at <http://www.ncdc.noaa.gov>. Accessed in October 2011.
- _____. 2010b. Monthly Station Normals of Temperature, Precipitation, and Heating and Cooling Degree Days, 1971-2000. *Climatology of the United States No. 81 – Texas*. Available at: <http://hurricane.ncdc.noaa.gov/climatenormals/clim81/TXnorm.pdf>. Accessed in January 2013.
- Texas Commission on Environmental Quality (TCEQ). 2010a. Air Monitoring Sites. 1974 to 2003. Available at: http://www.tceq.texas.gov/airquality/monops/sites/mon_sites.html.
- United States Environmental Protection Agency (EPA). 2011a. AirData Monitor Values Report Query, available at: http://www.epa.gov/airdata/ad_rep_con.html. Accessed January 29, 2013.
- _____. 2011b. 2008 National Emissions Inventory. Version 1.5. Available at: <http://www.epa.gov/ttn/chief/net/2008inventory.html>. Accessed November 4, 2011.

Section 3.3 (Geology and Soils)

- Aronow, S. and Heinrich, P.V. 2004. 04-01 Surface Geology of Calcasieu Parish. Baton Rouge: Louisiana Geological Survey.
- Baker, E.T. Jr. 1979. Stratigraphic and Hydrogeologic Framework of Part of the Coastal Plain of Texas, Texas Department of Water Resources, Report 236.
- Bureau of Economic Geology. 1996. Physiographic Map of Texas 1996: Information Sheet. Available at: <http://www.lib.utexas.edu/geo/fieldguides/physiography.html>.
- Chowdhury, A.H. and M.J. Turco. 2006. Chapter 2: Geology of the Gulf Coast Aquifer, Texas. In: *Aquifers of the Gulf Coast of Texas*. Texas Water Development Board, Report 365.
- Crenwelge, G.W., J.D. Crout, E.L. Griffin, M.L. Golden, and J.K. Baker. 1981. *Soil Survey of Brazoria County, Texas*. USDA Soil Conservation Service.
- Fenneman, N.M. and D.W. Johnson. 1946. *Physiographic Divisions of the Conterminous U.S.* Washington, D.C., U.S. Geological Survey.

- Hancock, Paul and Brian Skinner. 2000. "Growth Fault." *The Oxford Companion to the Earth*. Available at: <http://www.encyclopedia.com/doc/1O112-growthfault.html>. Accessed on December 06, 2011.
- LBG-Guyton Associates. 2003. *Brackish Groundwater Manual for Texas Regional Water Planning Groups*. Prepared for the Texas Water Development Board.
- Louisiana Geological Survey. 2011. Louisiana Geofacts Public Information Series No. 6. Available online at: <http://www.lgs.lsu.edu/depoy/uploads/6geofacts.pdf>. Web site accessed on June 26, 2011.
- Louisiana Oil Spill Coordinators Office (LOSCO). n.d. Locations of oil and gas wells near the proposed project in Calcasieu Parish, Louisiana. Available at: <http://www.losco.state.la.us/products&publications.htm>.
- Roy, A.J. and C.T. Midkiff. 1988. *Soil Survey of Calcasieu Parish, Louisiana*. U.S. Department of Agriculture, Soil Conservation Service.
- U.S. Department of Agriculture, Natural Resources Conservation Service. 2011. Soil Survey Geographic (SSURGO) database for Calcasieu Parish, Louisiana.
- U.S. Department Of Energy (DOE), National Energy Technology Laboratory. 2011. Environmental Assessment For Air Products and Chemicals, Inc. RecoveryAct: Demonstration Of CO₂ Capture And Sequestration Of Steam Methane Reforming Process Gas Used For Large Scale Hydrogen Production, Jefferson and Brazoria Counties, Texas. (DOE/EA-1846D).
- U.S. Geological Survey (USGS). 2003. *The National Atlas*. A Tapestry of Time and Terrain. Available online at: <http://nationalatlas.gov/tapestry/physiogr/physio.html>
- _____. 2011. National Seismic Hazards Map – 2008. Available online at: <http://earthquake.usgs.gov/hazards/apps/gis/>. Web site accessed on November 3, 2011.

Section 3.4 (Surface Water)

- Air Products and Chemicals, Inc. (APCI). 2011. *Environmental Assessment: Demonstration of CO₂ Capture and Sequestration of Steam Methane Reforming Process Gas Used for Large Scale Hydrogen Production, Final*. Prepared for the U.S. Department of Energy, National Energy Technology Laboratory.
- Bayou d'Inde Group. 2009. Corrective Action Study Report, Bayou D'Inde Site, Calcasieu Parish, Louisiana Agency Interest 7443. August 2009. Pages 1-99. Available online through US Geological Survey Upper Midwest Environmental Services Center Products and Publications at: (http://www.umesc.usgs.gov/wildlife_toxicology/study_sites/louisiana/wt_la_lake_calcasieu_bayou_dinde.html). Accessed on October 31, 2011.

- City of Sulphur. 2012. Information on City of Sulfur local water supply. Available at: <http://www.sulphur.org/departments/division.php?fDD=3-9>. Accessed on November 29, 2011.
- CH2M Hill. 2011. Denbury Onshore, LLC Lake Charles Pipeline Lateral Project, USACE Pre-Construction Notification (PCN) for Nationwide Permit 12, 2011.
- Coenco. 1985. Flood Control Planning Study on Chigger and Cowarts Creeks in and for the City of Friendswood, Texas, and the Texas Water Development Board. Available online at: www.twdb.state.tx.us/rwpg/rpgm_rpts/5541007a.pdf. Web site accessed on October 31, 2011.
- Denbury. 2013. Lake Charles Pipeline Lateral Project, updated tables. Email from B. Atchison (Denbury) to P. Fayish (NETL) and J. Whitken (E & E). Sent February 4, 2013.
- Federal Emergency Management Agency (FEMA). 2010. FEMA Map Service Center. Flood Insurance Rate Maps for Calcasieu Parish, Louisiana. Available online at: http://msc.fema.gov/webapp/wcs/stores/servlet/CategoryDisplay?storeId=10001&catalogId=10001&langId=-1&categoryId=12001&parent_category_rn=12001&type=CAT_MAPPANEL&stateId=13025&countyId=14150&communityId=343787&stateName=LOUISIANA&countyName=CALCASIEU+PARISH&communityName=LAKE+CHARLES%2CCCTY%2FCALCASIEU+PAR&dfirm_kit_id=&future=false&dfirmCatId=null&isCountySelected=&isCommSelected=&userType=G&urlUserType=G&sfc=0&cat_state=13025&cat_county=14150&cat_community=343787.
- Levingston Engineers, Inc. 2011. Lake Charles Cogeneration LLC Drainage and Bulkhead Key Plan, Drawing No 100243-C-01. Lake Charles, Louisiana.
- Louisiana Department of Environmental Quality (LDEQ). 2000. Houston River Watershed TMDL for Biochemical Oxygen-Demand Substances, Sub-segment 030806, Surveyed September 19-21, 2000. TMDL Report, available online at: www.deq.state.la.us/portal/portals/0/.../Houston-River-report.pdf. Web site accessed October 31, 2011.
- _____. 2001. Houston River Watershed TMDL Report for Biochemical Oxygen-Demanding Substrates Subsegment 030806, prepared by Engineering Group 2, Environmental Technology Environmental Technology Division, Office of Environmental Assessment. Revised September 5, 2001, and December 5, 2001.
- _____. 2010. Letter dated June 18, 2010, from Thomas F. Harris, Administrator, Remediation Services Division, to Donald Brinkman, Port of Lake Charles, Louisiana Department of Environmental Quality. SUMMARY/JUSTIFICATION, Lake Charles Harbor & Terminal District (Port of Lake Charles) Cogeneration Project AI #160213, Calcasieu Parish.

- _____. 2011. Louisiana State Water Quality Inventory: Integrated Report Fulfilling Requirements of the Federal Clean Water Act, Sections 305(b) and 303(d). Office of Environmental Services, Water Permits Division, Baton Rouge, Louisiana.
- National Climatic Data Center (NCDC). 2011. Lake Charles Historic Severe Weather Data. Available online at:
http://www.ncdc.noaa.gov/stormevents/listevents.jsp?beginDate_mm=10&beginDate_dd=01&beginDate_yyyy=2006&endDate_mm=10&endDate_dd=31&endDate_yyyy=2012&eventType=ALL&county=CALCASIEU&zone=NONE&submitbutton=Search&statefips=22%2CLOUISIANA. Web site accessed on October 23, 2011.
- _____. 2011. Water Level Stations by State. Available at:
<http://tidesonline.nos.noaa.gov/geographic.html>. Accessed on October 23, 2011.
- National Oceanographic and Atmospheric Administration (NOAA). 2011. General information on the Calcasieu River basin. Available at:
http://www.srh.noaa.gov/lmrfc/?n=calcasieu_swla.riverbasins. Accessed on October 23 2011 for
- _____. 2012a. Damage Assessment, Remediation, and Restoration Program (DARRP). Available at: http://www.darrp.noaa.gov/southeast/bayou_dinde/index.html Accessed on May 31, 2012.
- _____. 2012b. Damage Assessment, Remediation, and Restoration Program (DARRP). Available at:
http://www.darrp.noaa.gov/southeast/bayou_verdine/index.html. Accessed on May 31, 2012.
- Sabine River Association (SRA). 2011. Volumes of water diverted from the Sabine River for industrial uses. Available at: <http://12.6.56.180/index.php?q=content/history-0>. Accessed on October 23, 2011.
- Texas Commission on Environmental Quality (TCEQ). 2011a. Yearly Summary Report by Site. Available online at: <http://www.tceq.texas.gov/waterquality/assessment/10twqi/10twqi>
- _____. 2011b. Texas Integrated Report for Clean Water Act Sections 305(b) and 303(d). Available online at:
http://www.tceq.state.tx.us/compliance/monitoring/water/quality/data/wqm/305_303.html#fy2008.
- _____. 2011c. Chigger Creek Water Quality. Available online at:
<http://ntis04.hgac.cog.tx.us/website/bsr06/Clearcreektidal.pdf>. Web site accessed October 31, 2011.

United States Fish and Wildlife Service (USFWS). 2011. National Wetland Inventory Mapper. Available online at: <http://www.fws.gov/wetlands/Data/Mapper.html>.

United States Army Corps of Engineers (USACE). 1987. Environmental Laboratory. "Corps of Engineers Wetlands Delineation Manual," Technical Report Y-87-1, US Army Engineer Waterways Experiment Station, Vicksburg, Miss.

_____. 1998. Calcasieu River Basin. Water Resources Description 98, pages 150-157. Available at: http://www.mvn.usace.army.mil/pao/bro/wat_res98/WaterRes98_13of16.pdf.

_____. 2007. Jurisdictional Determination Form Instructional Guidebook, USACE and EPA, Washington, DC. Available online at: http://www.sas.usace.army.mil/regulatory/Policy_Procedures.html#JDFormInstrGuidebook

_____. 2009. Calcasieu River and Pass, Louisiana, Dredged Material Management Plan and Supplemental Environmental Impact Statement, Vol. 1. USACE New Orleans District, New Orleans, Louisiana.

_____. 2012. Lake Charles Pipeline Lateral Project, wetland areas. Email from R. Schwamenfeld (USACE) to J. Wallace (CH2M Hill). Sent December 18, 2012.

United States Environmental Protection Agency (EPA). 2011. <http://water.epa.gov/lawsregs/lawsguidance/cwa/tmdl/index.cfm> for regulatory information on impaired waters and TMDLs. Web site accessed on November 28, 2011.

United States Geological Survey (USGS). 2011. Real-time stream flow data for Texas. Available online at: http://waterdata.usgs.gov/tx/nwis/current/?type=flow&group_key=basin_cd#tx05. and http://waterdata.usgs.gov/la/nwis/current/?type=flow&group_key=basin_cd. Web sites accessed November 29, 2011.

URS Corporation (URS). 2007. *Phase I Environmental Site Assessment Report of the Lake Charles Cogeneration Gasification Project Property*. 30 pps.

_____. 2008. *Phase II Environmental Site Assessment Report of the Lake Charles Cogeneration Gasification Project Property*. June 2008.

_____. 2010. Lake Charles CCS Project Environmental Information Volume, Part I - CO₂ Capture and Compression Facilities at the Lake Charles Gasification Project.

Section 3.5 (Groundwater)

- Baker, E.T., Jr. 1979. *Stratigraphic and Hydrogeologic Framework of Part of the Coastal Plain of Texas*. Texas Department of Water Resources Report 236, 43 p.
- Brazoria County Groundwater Conservation District (BCGCD). 2008. Rules adopted May 8, 2008. Available online at: http://bcgroundwater.org/documents/BCGCD%20RULES%20&%20REGS%20as%20amended%205-8-08_.pdf.
- Lovelace, J. K. and P.M. Johnson. 1996. *Water Use in Louisiana, 1995*. Louisiana Department of Transportation and Development Water Resources Special Report no. 11, 127 p.
- Sandeen, W. M. and J. B. Wesselman, 1973. *Ground-Water Resources of Brazoria County, Texas*. Texas Water Development Board Report 163, 64 pages.
- Scanlon, B.R.; R. Reedy; G. Strassberg; Y. Huang; and G. Senayl. 2002. Estimation of Groundwater Recharge to the Gulf Coast Aquifer in Texas, USA. Final Contract Report to Texas Water Development Board. Bureau of Economic Geology, Jackson School of Geosciences, University of Texas, Austin and US Geological Survey, Sioux Falls, S. Dakota. Available on line at http://www.twdb.state.tx.us/publications/reports/contracted_reports/index.asp. Web site accessed on November 1, 2011.
- Southern Regional Water Program. 2011. Information on regional groundwater policies. Available at: <http://srwqis.tamu.edu/louisiana/program-information/louisiana-target-themes/water-quantity-policy>. Accessed on November 1, 2011.
- Texas Parks and Wildlife Department (TPWD). 2011. USGS Groundwater withdrawals in Louisiana by Parish. Available at: www.twdb.state.tx.us/gam/glfcn/SAF3_GC-n_PartB.pdf. Accessed on November 1, 2011.
- Texas Water Development Board (TWDB). 2011. Groundwater Wells in Brazoria County, Texas. Available at: <http://www.twdb.state.tx.us/publications/reports/GroundWaterReports/GWReports/R163/figure27.jpg>. Accessed on October 31, 2011.
- _____. 2002. Brazoria County Master Drainage Plan, report on hydrology and drainage. Prepared by Klotz Associates, Inc. Available at: http://www.twdb.state.tx.us/publications/reports/contracted_reports/index.asp.
- United States Census Bureau (USCB). 1993. 1990 Census of Housing; Detailed Housing Characteristics, Louisiana. Washington D.C. 337 p.
- United States Geological Survey (USGS). 1989. *Quality of Water in Freshwater Aquifers in Southwestern Louisiana*.

- _____. 2011a. Information on groundwater in Calcasieu Parish. Available at: http://groundwaterwatch.usgs.gov/countymaps/LA_019.html. Accessed on November 1, 2011.
- _____. 2011b. Louisiana Water Science Center. Information on groundwater wells in Calcasieu Parish. Available at: <http://la.water.usgs.gov/WellsByParishMap.asp?Parish=Calcasieu>. Accessed on November 1, 2011.
- Verbeek, E.R., K.W. Ratzlaff, and U.S. Clanton. 1979. Faults in parts of north-central and western Houston metropolitan area, Texas: U.S. Geological Survey Miscellaneous Field Studies Map MF-1136, 1 sheet.
- Whitfield, M.S., Jr. 1975. Geohydrology of the Jasper and Evangeline aquifers of southwestern Louisiana: Louisiana Department of Public Works Water Resources Technical Bulletin 20, 72 p.
- Zack, A.L. 1971. Groundwater pumpage and related effects, southwestern Louisiana, 1970, with a section of surface-water withdrawals: Louisiana Department of Conservation, Louisiana Geological Survey, and Louisiana Department of Public Works Water-Resources Pamphlet 27, 33 p.

Section 3.6 (Biology)

- Daigle, J.J., G.E. Griffith, J.M. Omernik, P.L. Faulkner, R.P. McCulloh, L.R. Handley, L.M. Smith, and S.S. Chapman. 2006. Ecoregions of Louisiana. U.S. Geological Survey, Reston, Virginia.
- Ehrlich, Paul, R., David, S. Dobkin, and Darryl Wheye. 1988. *The Birder's Handbook: A Field Guide to the Natural History of North American Birds*. New York: Simon and Schuster, Inc.
- Fry, J., G. Xian, S. Jin, J. Dewitz, C. Homer, L. Yang, C. Barnes, N. Herold, and J. Wickham. 2011. Completion of the 2006 National Land Cover Database for the Conterminous United States, PE&RS, Vol. 77(9):858-864. Available online at: <http://www.mrlc.gov/nlcd2006.php>.
- Hobbs, H.H. Jr., and H.W. Robison. 1989. On The Crayfish Genus *Fallicambarus* in Arkansas, with Notes on the Fodiens Complex and Descriptions of Two New Species. *Proceedings of the Biological Society of Washington* 102(3): 651-697.
- Lewis, J.C. 1995. Whooping Crane (*Grus americana*), in *The Birds of North America Online* (A. Poole, ed.). Ithaca: Cornell Laboratory of Ornithology. Available online at: <http://bna.birds.cornell.edu/bna/species/153>. Web site accessed on July 21, 2010.

- Lockwood, Mark, and Brush Freeman. 2004. *The Texas Ornithological Society Handbook of Texas Birds*. College Station: Texas A&M University Press.
- Louisiana Comprehensive Wildlife Conservation Strategy (LA CWCS). 2005. Conservation Habitats & Species Assessments, Calcasieu Basin. Available online at: www.wlf.louisiana.gov/sites/default/files/...calcasieu.../calcasieu.pdf
- Louisiana Department of Natural Resources (LDNR). 2011. Natural Communities of Louisiana, Mixed Hardwood-Loblolly Pine Forest. Available at: http://www.wlf.louisiana.gov/sites/default/files/pdf/fact_sheet_community/32370-Mixed%20Hardwood-Loblolly%20Pine/mixed_hardwood-loblolly_pine_forest.pdf.
- Louisiana Department of Wildlife and Fisheries (LDWF). 2004. *State Management Plan for Aquatic Invasive Species in Louisiana*. Draft. Louisiana Department of Wildlife and Fisheries, Baton Rouge, Louisiana.
- _____. 2008. Louisiana Natural Heritage Program. Rare, Threatened, and Endangered Species and Natural Communities - Calcasieu Parish. Available at: <http://www.wlf.louisiana.gov/wildlife/louisiana-natural-heritage-program>. Accessed on August 16, 2011.
- _____. 2011. Louisiana Natural Heritage Program. Available at: http://www.wlf.louisiana.gov/wildlife/species-parish-list?tid=216&type_1=All. Accessed on August 16, 2011.
- National Biological Information Infrastructure (NBII). 2011. Available at: http://www.nbii.gov/portal/server.pt/community/regional_ecoregions/1815/texas-louisiana_coastal_plains/6645. Accessed on August 16, 2011.
- Native Prairies Association of Texas (NPAT). 2011. *Tallgrass Restoration Manual*. Available at: http://texasprairie.org/index.php/manage/restoration_entry/tallgrass_restoration_manual/. Accessed on November 11, 2011.
- NatureServe. 2011. NatureServe Explorer Listed Species for Calcasieu Parish. Available at: <http://www.natureserve.org>. Accessed on October 12 2011.
- National Oceanic and Atmospheric Administration (NOAA). 2011a. Calcasieu Estuary. Available at: http://mapping2.orr.noaa.gov/portal/calcasieu/calc_html/calcenv.html. Accessed on November 11, 2011.
- _____. 2011b. EFH as defined in the Magnuson-Stevens Act. Available at: http://sero.nmfs.noaa.gov/hcd/efh_faq.htm#Q2. Accessed on November 11, 2011.

- _____. 2011c. Coastal migratory species. Available at:
<http://ccma.nos.noaa.gov/products/biogeography/gom-efh/offshore.aspx#coastal>.
Accessed on November 11, 2011.
- Pritchard, D.W. 1967. What is an estuary: physical viewpoint. In: Lauff G.H. (Ed.), *Estuaries*, American Association for the Advancement of Science, Washington DC, pp. 3-5.
- Texas Invasive Plant and Pest Council. 2011. Eco Alert by Region, Invasives 101. Available at: <http://www.texasinvasives.org>. Accessed on November 17, 2011.
- Texas Parks and Wildlife Department (TPWD). 2011a. Wildlife Division, Wildlife Management Districts. Available at:
http://www.tpwd.state.tx.us/landwater/land/habitats/oak_prairie. Accessed on November 18, 2011.
- _____. 2011b. Rare, Threatened and Endangered Species by County. Available at:
http://www.tpwd.state.tx.us/landwater/land/maps/gis/ris/endangered_species. Accessed on November 18, 2011.
- _____. 2011c. Texas Natural Diversity Database. Available at:
<http://txmn.org/elcamino/files/2010/03/Natural-Diversity-Database.PDF>. Accessed on November 18, 2011.
- Tulane University. 2011. Center for Bioenvironmental Research, Louisiana Invasive Species. Available at: <http://is.cbr.tulane.edu/PortalsAndPathways.html>. Accessed on November 11, 2011.
- URS Corporation. 2008. *Phase II Environmental Site Assessment Report of the Lake Charles Cogeneration Gasification Project Property*. June 2008.
- U.S. Army Corps of Engineers (USACE). 1998. Calcasieu River Basin. Water Resources Description 98, pages 150-157. Available at:
www.mvn.usace.army.mil/pao/bro/wat.../WaterRes98_13of16.pdf.
- U.S. Fish and Wildlife Service (USFWS). 1995. *Louisiana Black Bear Recovery Plan*. Prepared by B. Bowker and T. Jacobson and the Black Bear Conservation Committee. USFWS Jackson, Mississippi.
- _____. 2011a. National Wetland Inventory Mapper. Available at:
<http://www.fws.gov/wetlands/Data/Mapper.html>. Accessed on November 10, 2011.
- _____. 2011b. Mississippi Migratory Flyway. Available at:
<http://mississippi.flyways.us>.

_____. 2011c. Species by County Report: Calcasieu Parish, Louisiana. Environmental Conservation Online System. Available at: http://ecos.fws.gov/tess_public/countySearch!speciesByCountyReport.action?fips=22019 Accessed on November 18, 2011.

_____. 2011d. Species by County Report: Brazoria County, Texas. Environmental Conservation Online System. Available at: http://ecos.fws.gov/tess_public/countySearch!speciesByCountyReport.action?fips=48039 Accessed on November 18, 2011.

United States Geologic Survey (USGS). 2011. National Wetlands Research Center Coastal Prairie Research Program. Available at: <http://www.nwrc.usgs.gov/prairie/tcpr.htm>. Accessed on November 11, 2011.

Section 3.7 (Cultural Resources)

Breaux, Pam. 2012. Letter dated April 25, 2012, from Pam Breaux, State Historic Preservation Officer, Office of Cultural Development, Louisiana Department of Culture, Recreation & Tourism, Baton Rouge, Louisiana, to Joel Watkins, Cultural Resource Analyst, Office of Archaeological Research, Moundville, Alabama. RE: *Draft Report, La Division of Archaeology Report No. 22-4007, Phase I Cultural Resource Survey of the Proposed Lake Charles Pipeline Lateral Project located near Sulphur, Calcasieu Parish, Louisiana.*

Fayish, Pierina N. 2012. Letter dated August 15, 2012, from Pierina N. Fayish, NEPA Document Manager, National Energy Technical Laboratory, Department of Energy, Pittsburgh, Pennsylvania, to Pam Breaux, State Historic Preservation Officer, Office of Cultural Development, Louisiana Department of Culture, Recreation & Tourism, Baton Rouge, Louisiana. SUBJECT: *Initiation of Section 106 Consultation for Proposed Financial Assistance for the Lake Charles Carbon Capture and Sequestration (CCS) Project, Calcasieu Parish, Louisiana (and Brazoria County, Texas).*

_____. 2013. Letter dated January 25, 2013, from Pierina N. Fayish, NEPA Document Manager, National Energy Technical Laboratory, Department of Energy, Pittsburgh, Pennsylvania, to Dr. Ian Thompson, Director, Historic Preservation Program, Choctaw Nation of Oklahoma, Durant, Oklahoma. SUBJECT: *Section 106 Consultation for Proposed Financial Assistance for the Lake Charles Carbon Capture and Sequestration (CCS) Project, Calcasieu Parish, Louisiana (and Brazoria County, Texas).*

Handly, Martin. 2009. Letter dated June 15, 2009, from Martin Handly, Principal Investigator, URS Corporation, Baton Rouge, Louisiana, to Mr. Donald W. Maley, Vice-President, Lake Charles Cogeneration, LLC, Houston, Texas. RE: *Field Assessment of Archaeological Site 16CU29, Lake Charles Gasification Facility, Lake Charles Cogeneration, LLC, Westlake, Calcasieu Parish, Louisiana.*

- _____. 2012. Letter dated May 16, 2012, from Martin Handly, Principal Investigator, URS Corporation, Baton Rouge, Louisiana, to Mr. Philip Leonards, Leucadia Energy, Houston, Texas. Re: *Cultural Resources Evaluation - Lake Charles Cogeneration, LLC (LCC), Calcasieu Parish, Louisiana*.
- Hutcheson, Scott. 2009. Letter dated June 26, 2009, from Scott Hutcheson, State Historic Preservation Officer, Office of Cultural Development, Department of Culture, Recreation and Tourism, State of Louisiana, Baton Rouge, Louisiana. RE: *Lake Charles Gasification Facility, Lake Charles Cogeneration LLC, Agency Interest No. 160213, Activity No. PER20090001, Lake Charles, Calcasieu Parish, LA*.
- Karbula, James W., Ph.D. 2011. Letter dated October 25, 2011, from Dr. James W. Karbula, Regional Project Director, William Self Associates, Inc., Austin, Texas, to Patricia Mercado-Allinger, State Archaeologist, Archeology Division, Texas Historical Commission, Austin, Texas. Re: *Denbury Onshore, LLC, CO2 Sequestration Monitoring, Verification, and Accounting (MVA), Hastings Field, Brazoria County, Texas*.
- Louisiana Department of Culture, Recreation and Tourism (LA CRT). 2011. Louisiana Cultural Resources Map: Standing Structures and Historic Districts within 0.5 miles of Project Areas in Calcasieu Parish, Louisiana.
<http://kronos.crt.state.la.us/website/lahpweb/viewer.htm> (web site accessed March 7, 2011).
- _____. 2013. Field Standards of the Louisiana Division of Archaeology, Phase I Surveys: FieldStandards for Terrestrial Phase I Cultural Resources Surveys. Issued by the Office of CulturalDevelopment, Division of Archaeology. Available online at http://www.crt.state.la.us/archaeology/review/field_standards_terrestrial_phase_I_surveys.aspx (accessed March 20, 2013).
- National Park Service (NPS). 1990. *National Register Bulletin: How to Apply the National Register Criteria for Evaluation*. U.S. Department of the Interior, National Park Service, Cultural Resources/National Register, History and Education. Available at: <http://www.nps.gov/nr/publications/bulletins/pdfs/nrb15.pdf>. Accessed on December 1, 2011
- _____. 2011a. National Historic Landmarks Program, Lists of National Historic Landmarks: National Historic Landmarks Survey, Listing of National Historic Landmarks by State: Louisiana and Texas. Available at: <http://www.nps.gov/history/nhl/designations/Lists/LA01.pdf> and <http://www.nps.gov/history/nhl/designations/Lists/TX01.pdf>. Accessed on March 7, 2011.
- _____. 2011b. National Register of Historic Places, NPS Focus: Calcasieu Parish, Louisiana and Brazoria County, Texas. <http://nrhp.focus.nps.gov/natreghome.do>. Accessed on March 7, 2011.

- National Register of Historic Places. 2011. National Register of Historic Places: Calcasieu County, Louisiana and Brazoria County, Texas (State Listings and Historic Districts). <http://www.nationalregisterofhistoricplaces.com>. Accessed on March 7, 2011.
- Smith, R.L., M.E. Weed, A.I. Wilson, and A. Deter-Wolf. 2001. *Intensive Cultural Resources Survey – Citgo Petroleum Corporation, Lake Charles Refinery, Calcasieu Parish, Louisiana*. Report No. 22-2382, on file, Louisiana Division of Archaeology, Baton Rouge, Louisiana. Cited in letter dated June 15, 2009, from Martin Handly, Principal Investigator, URS Corporation, Baton Rouge, Louisiana, to Mr. Donald W. Maley, Vice-President, Lake Charles Cogeneration, LLC, Houston, Texas. RE: *Field Assessment of Archaeological Site 16CU29, Lake Charles Gasification Facility, Lake Charles Cogeneration, LLC, Westlake, Calcasieu Parish, Louisiana*.
- Texas Historical Commission. 2011. Texas Historic Sites Atlas. <http://atlas.thc.state.tx.us/shell-map-address.htm> (web site accessed March 7, 2011).
- Thompson, Ian, Dr. 2012. Letter dated December 20, 2012, from Dr. Ian Thompson, Director, Historic Preservation Program, Choctaw Nation of Oklahoma, Durant, Oklahoma, to Jesse Garcia, NETL Tribal Liaison, National Energy Technical Laboratory, Morgantown, West Virginia. RE: *National Energy Technology Laboratory, Proposed Financial Assistance for the Lake Charles Carbon Capture and Sequestration Project, Calcasieu Parish, Louisiana and Brazoria County, Texas*.
- _____. 2013. Letter dated March 2, 2013, from Dr. Ian Thompson, Director, Historic Preservation Program, Choctaw Nation of Oklahoma, Durant, Oklahoma, to Jesse Garcia, NETL Tribal Liaison, National Energy Technical Laboratory, Morgantown, West Virginia. RE: *National Energy Technology Laboratory, Proposed Financial Assistance for the Lake Charles Carbon Capture and Sequestration Project, additional info received, Calcasieu Parish, Louisiana and Brazoria County, Texas*.
- URS Corporation. 2012. *Lake Charles Cogeneration, LLC, Cultural Resources Assessment, Calcasieu Parish, Louisiana*. URS Job No. 10003620, July 2012.
- Watkins, Joel H., and Eugene M. Futato. November 2011. *A Phase I Cultural Resources Survey of the Proposed Lake Charles Pipeline Lateral Project Located near Sulphur, Calcasieu parish, Louisiana* (Draft Report). Performed by The University of Alabama, Office of Archaeological Research, Moundville, Alabama. Performed for CH2M HILL, Atlanta, Georgia.
- Wolfe, Mark. 2011. Letter dated November 1, 2011, from Mark Wolfe, State Historic Preservation Officer, Texas Historical Commission, Austin, Texas, to James Karbula, William Self Associates, Inc., Austin, Texas. Re: *Project Review under Section 106 of the National Historic Preservation Act of 1966 and the Antiquities Code of Texas, Denbury Onshore, LLC, CO2 Sequestration Monitoring, Verification, and Accounting (MVA), Hastings Field, Brazoria County, Texas*.

Section 3.8 (Land Use)

- CH2M Hill. 2011. Response to EIS Data Request: Pipeline. Prepared for the Lake Charles Pipeline Lateral Project. October 2011.
- Fry, J., G. Xian, S. Jin, J. Dewitz, C. Homer, L. Yang, C. Barnes, N. Herold, and J. Wickham. 2011. Completion of the 2006 National Land Cover Database for the Conterminous United States, PE&RS, Vol. 77(9):858-864. Available at: <http://www.mrlc.gov/nlcd2006.php>.
- Louisiana Department of Wildlife and Fisheries (LDWF). 2011. Louisiana Natural and Scenic Rivers Program. Available at: <http://www.wlf.louisiana.gov/wildlife/scenic-rivers>. Accessed on October 20, 2011.
- Louisiana State Land Office (LSLO). 2011. Conservation Lands and Public Trust Lands. Available at: <http://doa.louisiana.gov/slo>. Accessed on October 20, 2011.
- National Park Service (NPS). 2011. U.S. Department of the Interior, National Parks System. Available at: <http://www.nps.gov/state/la/index.htm>. Accessed on October 20, 2011.
- National Scenic Byways Program. 2010. Louisiana Scenic Byways. Available at: <http://www.byways.org>. Accessed in February 2010.
- U.S. Department of Agriculture (USDA). 2011. U.S. Forest Service, State Forests and Recreational Areas. Available at: http://www.fs.fed.us/recreation/map/state_list.shtml#Louisiana. Accessed on October 20, 2011.
- U.S. Fish and Wildlife Service (USFWS). 2011. America's National Wildlife Refuge System. Available at: <http://www.fws.gov/refuges/refugeLocatorMaps/Louisiana.html>. Accessed on October 20, 2011.
- Wallace, Jennifer. 2011. Telephone communication between Jennifer Wallace, Assistant Director of Planning, Calcasieu Parish Police Jury, Lake Charles, Louisiana, and Cristine Reguera, re: verification of proposed project's compatibility with Parish's future land use plans and/or comprehensive plans. November 16, 2011.
- Wild and Scenic Rivers Council (WSRC). 2010. National Wild and Scenic Rivers. Available at: <http://www.rivers.org>. Accessed in February 2010.

Section 3.9 (Socioeconomics)

- Alvin Police Department. 2011. "Alvin Police Department: About Our Organization." Accessed on November 4, 2011 at <http://www.alvinpolice.com/aboutAPD.shtml>
- Alvin Volunteer Fire Department. 2011. "Alvin, Texas Fire Department: Purpose of the Fire Department." Accessed on November 4, 2011 at <http://www.alvin-tx.gov/default.aspx?name=fireddept.homepage>
- Brazoria County, Texas. 2011. Comprehensive Annual Financial Report for Fiscal Year Ending September 30, 2010, Accessed November 3, 2011 at <http://www.brazoria-county.com/Auditor/docs/2010.PDF%20Complete%20audit.pdf>
- Brazoria County Fire Fighters Association. 2011. "Brazoria County Fire Fighters Association: United to Serve the People of Brazoria County". Accessed on November 4, 2011 at <http://www.bcffa.us/Member-Departments.html>
- Calcasieu Parish, Division of Finance. 2010. Comprehensive Annual Financial Report for the Fiscal Year Ended December 31, 2010. <http://www.cppj.net/Modules/ShowDocument.aspx?documentid=1826>. Calcasieu Parish, Louisiana. Accessed on November 03, 2011.
- Calcasieu Parish Sheriff's Office. 2011. "Calcasieu Parish – Patrol Department." Accessed on November 4, 2011 at http://www.cpsso.com/services/crime_lab.cfm
- Council on Environmental Quality (CEQ), 1997. *Environmental Justice: Guidance Under the National Environmental Policy Act*. Accessed on November 28, 2011. at http://www.epa.gov/compliance/ej/resources/policy/ej_guidance_nepa_ceq1297.pdf
- City of Alvin, Texas. 2011. Comprehensive Annual Financial Report for Fiscal Year Ending September 30, 2011. Available online at: <http://www.alvin-tx.gov/docs/4-2010CAFR.pdf>. Web site accessed on November 3, 2011.
- City of Pearland, Texas. 2010. Comprehensive Annual Financial Report for Fiscal Year Ending September 30, 2010. Available at: <http://www.cityofpearland.com/vertical/Sites/%7BCA80BAF8-A883-4878-AB6D-7FC8DAE7D62E%7D/uploads/%7B4582A29F-1AD5-4077-AE9C-096C00FC8A20%7D.PDF>. Accessed on November 3, 2011.
- City of Sulphur. 2010. Department of Finance. Annual Financial Report for Fiscal Year Ended June 30, 2010. http://www.sulphur.org/egov/docs/1294672714_460144.pdf. City of Sulphur, Louisiana. Accessed on November 03, 2011.
- Louisiana Interagency Coordination Center. 2011. "LICC Fire Department Information Center." http://www.fs.fed.us/outernet/r8/kisatchie/licc/site/parish/calcasieu_parish.htm. Accessed on November 4, 2011.

- Louisiana Tax Commission. 2010. Annual Report 2010.
http://www.latax.state.la.us/Menu_AnnualReports/UploadedFiles/Louisiana%20Tax%20Commission%20Annual%20Report%202010.pdf. Accessed October 30, 2011.
- Pearland Fire Department. 2011. "About the Pearland Fire Department". Accessed on November 4, 2011 at <http://www.pearlandfire.org/about/>
- Pearland Police Department. 2011. "2010 Annual Report." Accessed on November 4, 2011 at <http://cityofpearland.com/vertical/Sites/%7BCA80BAF8-A883-4878-AB6D-7FC8DAE7D62E%7D/uploads/%7B3FC334D2-6D5F-4054-9E80-CFD60E14F674%7D.PDF>
- U.S. Bureau of Labor Statistics, 2011. Local Area Unemployment Statistics, Accessed on October 31, 2011 at <http://data.bls.gov/pdq/SurveyOutputServle>
- U.S. Department of Commerce, Bureau of the Census (USCB). 2000. Census 2000 Demographic Profile Highlights (City of Sulphur, LA; Calcasieu Parish, LA; State of Louisiana; City of Alvin, TX; City of Pearland, TX; Brazoria County, TX; Jefferson County, TX; and State of Texas).
http://factfinder.census.gov/home/saff/main.html?_lang=en. Accessed October 29, 2011.
- _____. 2009. 2005-2009 American Community Survey 5-Year Estimates (City of Sulphur, LA; Calcasieu Parish, LA; State of Louisiana; City of Alvin, TX; City of Pearland, TX; Brazoria County, TX; Jefferson County, TX; and State of Texas).
http://factfinder.census.gov/home/saff/main.html?_lang=en. Accessed October 29, 2011.
- _____. 2010. Profile of General Population and Housing Characteristics: 2010 (City of Sulphur, LA; Calcasieu Parish, LA; State of Louisiana; City of Alvin, TX; City of Pearland, TX; Brazoria County, TX; Jefferson County, TX; and State of Texas).
<http://factfinder2.census.gov/main.html>. Accessed October 29, 2011.
- _____. 2011. Median Household Income in the Past 12 Months (in 2010 Adjusted Dollars). Available at:
<http://factfinder2.census.gov//tableservices/jsf/pages/productview.xhtml?ftp=table>. Accessed on November 3, 2011.

Section 3.10 (Traffic and Transportation)

AIRNAV. 2011a. Southland Field Airport FAA Information, effective October 20, 2011. Available online at: <http://www.airnav.com/airport/KUXL>. Web site accessed on December 7, 2011.

_____. 2011b. Pearland Regional Airport FAA Information, effective October 20, 2011. Available online at: <http://www.airnav.com/airport/KLVJ>. Web site accessed on October 20, 2011.

_____. 2011c. William P. Hobby Airport FAA Information, effective October 20, 2011. Available online at: <http://www.airnav.com/airport/KHOU>. Web site accessed on October 20, 2011.

Imperial Calcasieu Police Jury (ICPJ). 2009. *Vision Calcasieu: Calcasieu Parish Comprehensive Parish Plan*. Lake Charles, Louisiana.

Imperial Calcasieu Regional Planning & Development Commission (IMCAL). 2009. *Lake Charles Urbanized Area Long-Range Transportation Master Plan*. Lake Charles, Louisiana.

Louisiana Department of Transportation and Development (LDOTD). 2003. Statewide Transportation and Infrastructure Plan. Available at: <http://www.dotd.la.gov/study>. Accessed on May 31, 2012.

_____. 2010. Average Annual Traffic Data for Calcasieu Parish, Louisiana. Available at: <http://www.dotd.la.gov/highways/tatv/default.asp>. Accessed on July 2, 2012.

_____. 2012a. Official District 7 Map. Baton Rouge, Louisiana. Available at: http://www.dotd.la.gov/planning/mapping/District%20Maps/District_07.pdf. Accessed on March 4, 2012.

_____. 2012b. Lake Charles Roadway Functional Classification Map. Available at: http://www.dotd.la.gov/planning/maps_classification/urbanized/Lake_Charles.pdf. Accessed on March 4, 2012.

_____. 2012c. LDOTD District 7 unpublished LOS estimates for selected roadways in Calcasieu Parish, Louisiana. Received via email from Tyson Thevis, LDOTD, to Komi Hassan, E & E, on August 23, 2012.

Port of Lake Charles. 2011. Port of Lake Charles homepage. Available at: <http://www.portlc.com/AboutUs.asp>. Accessed on November 4, 2011.

Transportation Research Board (TRB). 2010. *Highway Capacity Manual*. 5th Edition. The National Academy of Sciences, Washington D.C.

Wilbur Smith Associates. 2002. The National I-10 Freight Corridor Study: Technical Memorandum Number Two, Description of Existing Conditions. Houston, Texas.

Section 3.11 (Noise)

ATCO Noise Management (ATCO). 2012. *Lake Charles Carbon Capture & Sequestration (CCS) Project Environmental Noise Survey & Noise Impact Assessment*. Prepared for Leucadia Energy, LLC. March 7, 2012.

Cowen, James P. 1994. *Handbook of Environmental Acoustics*. John Wiley & Sons, Inc.

Hoover & Keith, Inc. (H&K). 2012. *Acoustical Assessment of the Planned HDDs Associated with the Lake Charles CO₂ Pipeline Lateral Project for Denbury Onshore*. Prepared for CH2M Hill, Inc. March 14, 2012.

United States Department of Labor, Occupational Safety and Health Administration. 2011. Occupational Noise Exposure. Available at: <http://www.osha.gov/SLTC/noisehearingconservation>. Accessed on November 22, 2011.

Section 3.12 (Waste and Materials)

CH2M Hill. 2011. *Response to the EIS Data Request, Pipeline*. Prepared for the Lake Charles Pipeline Lateral Project. October 2011.

Louisiana Department of Environmental Quality (LDEQ). n.d. Summary/Justification for Lake Charles Harbor & Terminal District (Port of Lake Charles) Cogeneration Project. AI No.160213. Calcasieu Parish, Baton Rouge, Louisiana.

Louisiana Department of Environmental Quality (LDEQ). June 18, 2010. Correspondence, re: Lake Charles Harbor and Terminal District (Port of Lake Charles) Cogeneration Project: Site Development; AI Number 160213, Bayou D'Inde Road, Westlake, Calcasieu Parish, Louisiana. To: Mr. Donald Brinkman, Port of Lake Charles.

Louisiana Department of Environmental Quality (LDEQ). 2010. Municipal, Construction Debris, and Industrial Solid Waste Capacity Report. Baton Rouge, Louisiana, June 18, 2010.

Texas State Historical Association (TSHA). 2011. Hastings Oilfield. Available at: <http://www.tshaonline.org/handbook/online/articles/doh01>. Accessed on November 22, 2011.

URS. 2007. Phase I Environmental Site Assessment of the Port of Lake Charles Property, Westlake, Louisiana. Prepared for Lake Charles Cogeneration, LLC. November 2007.

URS. 2008. Phase II Environmental Site Assessment for the Lake Charles Harbor and Terminal D Tract Property. Westlake, Louisiana. November 2007.

URS, Inc. (URS). 2008. *Phase II Environmental Site Assessment Report for Lake Charles Harbor and Terminal District Property*. Westlake, Louisiana. June 2008.

United States Environmental Protection Agency (EPA). 2011. Enviromapper. On-line dataset of EPA-regulated facilities. Available at: <http://www.epa.gov/enviro>. Accessed in September 2011.

Section 3.13 (Public Health and Safety)

City_Data.com. 2011. Socioeconomic data for the City of Lake Charles, Louisiana. Available at: <http://www.city-data.com/city/Lake-Charles-Louisiana.html>.

Flury F, Zernik F [1931]. *Schädliche gase dämpfe, nebel, rauch- und staubarten*. Berlin, Germany: Verlag von Julius Springer, p. 299 (in German).

Intergovernmental Panel on Climate Change (IPCC), 2005 – Carbon Dioxide Capture and Storage, Bert Metz, Ogunlade Davidson, Heleen de Coninck, Manuela Loos and Leo Meyer (Eds.), Cambridge University Press, UK. pp 431. Available at: http://www.ipcc.ch/publications_and_data/publications_and_data_reports.shtml#.UQATvGd9Q7w. Accessed in February 2010.

U.S. Department of Energy (DOE). 2007. National Energy Technology Laboratory. Carbon Sequestration Program Environmental Reference Document. Available at: http://www.netl.doe.gov/technologies/carbon_seq/refshelf/nepa/index.html. Accessed on March 7, 2011.

Chapter 4: Environmental Consequences

Section 4.1: (Introduction)

None.

Section 4.2 (Climate and Air Quality)

Air Products and Chemicals, Inc. (APCI). 2011. *Environmental Assessment: Demonstration of CO₂ Capture and Sequestration of Steam Methane Reforming Process Gas Used for Large Scale Hydrogen Production, Final*. Prepared for the U.S. Department of Energy, National Energy Technology Laboratory.

American Petroleum Institute (API). 2009. *Compendium of Greenhouse Gas Emissions Methodologies for the Oil and Natural Gas Industry*. August 2009.

Leucadia Energy, LLC. 2011. Email from Larry Laub, Leucadia Energy, LLC, to Janine Whitken, Ecology and Environment, Inc., re: LCC EIS Air Question No. 5. Sent on November 30, 2011.

- _____. 2012. Comment from Larry Leib, Leucadia Energy, LLC, on the June 2012 Preliminary Draft EIS, received on July 3, 2012.
- Louisiana Department of Environmental Quality (LDEQ). 2012a. Calcasieu Parish Section 110(a)(1) Maintenance Plan, Final, July 2007. Available at: <http://www.deq.louisiana.gov/portal/DIVISIONS/AirPermitsEngineeringandPlanning/AirQualityPlanning/LouisianaSIPRevisions/CalcasieuParishSection110a1MaintenancePla.aspx>. Accessed in June 2012.
- _____. 2012b. Part 70 Operating Permit Modification, Lake Charles Gasification Facility, Agency Interest No. 160213, Permit Number 0520-00411-V2, Lake Charles Energy LLC. Permit dated June 29, 2012.
- U.S. Environmental Protection Agency (EPA). 1990. Draft New Source Review Workshop Manual. October 1990. Available at: <http://www.epa.gov/ttn/nsr/gen/wkshpman.pdf>. Accessed in June 2012.
- _____. 1995. AP-42, *Compilation of Air Pollutant Emission Factors*, Chapter 13.2.3, Heavy Construction Operations. January 1995.
- _____. 2012. United States Environmental Protection Agency, eGRID2010 Version 1.1. Available at: http://www.epa.gov/cleanenergy/documents/egridzips/eGRID2010V1_1_year07_SummaryTables.pdf. Accessed on January 20, 2012.
- URS Corporation (URS). 2008. Lake Charles Cogeneration, LLC, Title V Permit Application and Prevention of Significant Deterioration Study, LDEQ Agency Interest No. 160213, Permit No. 0520-00411-V0. Letter of transmittal receipt dated September 23, 2008.
- Section 4.3 (Geology and Soils)**
- CH2MHill. 2011. Response to Request for Additional Information, Denbury Environmental Impact Statement. MVA Response. October 2011.
- International Conference of Building Officials (ICBO). 1997. Uniform Building Code, Structural Engineering Provisions, Vol. 2, 1997 edition, pp. 2-161 to 2-163, International Conference of Building Officials, Whittier, California.
- United States Geological Survey (USGS). 1998. Wheeler, R.L., and P.V. Heinrich, compilers. Fault number 1022, Gulf-margin normal faults, Louisiana and Arkansas, in Quaternary fault and fold database of the United States. Available at: <http://earthquakes.usgs.gov/regional/qfaults>. Accessed on August 29, 2012.

Section 4.4 (Surface Water, Floodplains, and Wetlands)

- CH2M Hill 2011. Nationwide Permit 12 Pre-construction Notification Summary Report, Lake Charles Pipeline Lateral Project. Unpublished report submitted to USACE New Orleans District, December 7.
- Conner, Tim. 2012. Letter from Tim Conner, Calcasieu Parish Police Jury Division of Engineering and Public Works, to Martin Benoit, P.E., Levingston Group, LLC. February 14, 2012.
- Denbury. 2013. Lake Charles Pipeline Lateral Project, updated tables. Email from B. Atchison (Denbury) to P. Fayish (NETL) and J. Whitken (E & E). Sent February 4, 2013.
- Sabine River Authority (SRA). n.d. Information on the SRA's Toledo Bend Project on the Sabine River. Available at: <http://www.sratx.org/projects/tbp.asp>. Accessed on February 28, 2013.
- URS 2012. Lake Charles Cogeneration EIS Support Project URS Job No. 10003620, unpublished report prepared for Lake Charles Cogeneration LLC. Calcasieu parish, Louisiana. 21 pages. March 2012.
- USACE. 2012. Lake Charles Pipeline Lateral Project, wetland areas. Email from R. Schwamenfeld (USACE) to J. Wallace (CH2M Hill). Sent December 18, 2012.

Section 4.5 (Groundwater Impacts)

- Baker, E.T., Jr. 1979. Stratigraphic and hydrogeologic framework of part of the Coastal Plain of Texas: TDWR Report 236, 43 p.
- Kharaka, Y.K., J.J. Thordsen, E. Kakouros, G. Ambats, W.N. Herkelrath, S. R. Beers, J.T. Birkholzer, J.A. Apps, N.F. Spycher, L. Zheng, R.C. Trautz, H.W. Rauch, and K.S. Gullickson. 2010. Changes in the chemistry of shallow groundwater related to the 2008 injection of CO₂ at the ZERT field site, Bozeman, Montana. *Environ Earth Science* 60:273-284. Available at: <http://link.springer.com/article/10.1007%2Fs12665-009-0401-1?LI=true#page-1>. Accessed on January 10, 2012.
- Kharaka, Y.K., D.R. Cole, S.D. Hovorka, W.D. Gunter, K.G. Knauss, and B.M. Freifeld. 2006. *Gas-water-rock interactions in Frio Formation following CO₂ injection: Implications for the storage of greenhouse gases in sedimentary basins*. *Geology*, July, v. 34, p. 577-580. Available at: <http://geology.gsapubs.org/content/34/7/577.abstract?sid=2c180952-6f8b-4e28-99bc-86c3c344a8ec> <http://link.springer.com/article/10.1007%2Fs12665-009-0401-1?LI=true#page-1>.
- Lovelace, J. K. and P.M. Johnson. 1996. Water Use in Louisiana, 1995: Louisiana department of Transportation and Development Water resources, Special report no. 11, 127 p. -

Nicot, J.P., and Hovorka, S. D., 2009, Chapter 17. Leakage pathways from potential CO₂ storage sites and importance of open traps: case of the Texas Gulf Coast, *in* Carbon dioxide sequestration in geological media—state of the science: AAPG *Studies in Geology*, 59, M. Grobe, J.C. Pashin, and R.L. Dodge, eds., p. 321–334.

Sargent, B.P., and B.D McGee. 1998. Occurrence of nitrate and selected water-quality data, Chicot aquifer system in southwestern Louisiana, July 1994 through January 1996: Louisiana Department of Transportation and Development Water Resources Technical Report no. 64, 53 p. Available at:
<http://la.water.usgs.gov/publications/hydrostudies.html>. Accessed on January 10, 2012.

Wiseman, Paul, and S.D. Hovorka. 2010. Importance of CO₂ monitoring increases as environmental questions grow: Midland Reporter-Telegram, December 15 [including extensive quotes by Hovorka]. Available at:
http://www.mywesttexas.com/business/oil/article_4212f023-29c5-5018-87cb-bbda76cfeed6.html. Accessed on January 10, 2012.

Section 4.6 (Biological Resources)

CH2M Hill. 2011. Nationwide Permit No. 12 Pre-construction Notification Summary Report. unpublished report prepared for Denbury Onshore, LLC. December 7, 2011. CH2M Hill Atlanta, Georgia. 63 pages.

Lester, Gary. 2009. Letter dated May 28, 2009, from Gary Lester, Coordinator, Natural Heritage Program, Office of Wildlife, Department of Wildlife and Fisheries, Baton Rouge, Louisiana to Lawrence R. Leib, Lake Charles Cogeneration, LLC, Houston, Texas. RE: *Review of Preliminary Data for Project 5280901 Invoice Number 09052801*.

Section 4.7 (Cultural Resources)

Advisory Council on Historic Preservation (ACHP). 2004. 36 CFR Part 800 – Protection of Historic Properties (incorporating amendments effective August 5, 2004). Accessed online at <http://www.achp.gov/regs-rev04.pdf>. Web site accessed November 17, 2011.

Breaux, Pam. 2012. Letter dated April 25, 2012, from Pam Breaux, State Historic Preservation Officer, Office of Cultural Development, Louisiana Department of Culture, Recreation & Tourism, Baton Rouge, Louisiana, to Joel Watkins, Cultural Resource Analyst, Office of Archaeological Research, Moundville, Alabama. RE: *Draft Report, La Division of Archaeology Report No. 22-4007, Phase I Cultural Resource Survey of the Proposed Lake Charles Pipeline Lateral Project located near Sulphur, Calcasieu Parish, Louisiana*.

- Fayish, Pierina N. 2012a. Letter dated August 15, 2012, from Pierina N. Fayish, NEPA Document Manager, National Energy Technology Laboratory, Department of Energy, Pittsburgh, Pennsylvania, to Pam Breaux, State Historic Preservation Officer, Office of Cultural Development, Louisiana Department of Culture, Recreation & Tourism, Baton Rouge, Louisiana. SUBJECT: *Initiation of Section 106 Consultation for Proposed Financial Assistance for the Lake Charles Carbon Capture and Sequestration (CCS) Project Calcasieu Parish, Louisiana (and Brazoria County, Texas).*
- Fayish, Pierina N. 2012b. Letter dated August 15, 2012, from Pierina N. Fayish, NEPA Document Manager, National Energy Technology Laboratory, Department of Energy, Pittsburgh, Pennsylvania, to Mark Wolfe State Historic Preservation Officer, Texas Historical Commission, Austin, Texas. SUBJECT: *Section 106 Consultation for Proposed Financial Assistance for the Lake Charles Carbon Capture and Sequestration (CCS) Project Brazoria County, Texas (and Calcasieu Parish, Louisiana).*
- Handly, Martin. 2012. Letter dated May 16, 2012, from Martin Handly, Principal Investigator, URS Corporation, Baton Rouge, Louisiana, to Mr. Philip Leonards, Leucadia Energy, Houston, Texas. Re: *Cultural Resources Evaluation - Lake Charles Cogeneration, LLC (LCC), Calcasieu Parish, Louisiana.*
- Handly, Martin. 2009. Letter dated June 15, 2009, from Martin Handly, Principal Investigator, URS Corporation, Baton Rouge Louisiana, to Donald W. Maley, Vice-President, Lake Charles Cogeneration, LLC, Houston, Texas. Re: *Field Assessment of Archaeological Site 16CU29, Lake Charles Gasification Facility, Lake Charles Cogeneration, LLC, Westlake, Calcasieu Parish, Louisiana.*
- Handly, Martin. 2012. Letter dated May 16, 2012, from Martin Handly, Principal Investigator, URS Corporation, Baton Rouge, Louisiana, to Mr. Philip Leonards, Leucadia Energy, Houston, Texas. Re: *Cultural Resources Evaluation - Lake Charles Cogeneration, LLC (LCC), Calcasieu Parish, Louisiana.*
- Hardey, Jerry, and Bobbie Hardey. 2012. Letter dated September 18, 2012, from Jerry Hardey and Bobbie Hardey, Westlake, Louisiana, to Lee Sonnier, Landman, Denbury Gulf Coast Pipelines, LLC, Plano Texas. Re: *Letter of No Objection, Proposed Pipeline Construction under Hardey Family Cemetery, Denbury Tract LC.LA.CA.0055.000.*
- Hutcheson, Scott. 2008. Letter dated October 28, 2008, from Scott Hutcheson, State Historic Preservation Officer, Division of Archaeology, Office of Cultural Development, Louisiana Department of Culture, Recreation & Tourism, Baton Rouge, Louisiana, to Donald W. Maley, Vice President, Lake Charles Cogeneration, LLC, Houston, Texas. Re: *Air Permit Application: Lake Charles Gasification Facility, Lake Charles Cogeneration, LLC, Calcasieu Parish, Louisiana.*

- Hutcheson, Scott. 2009. Letter dated June 26, 2009, from Scott Hutcheson, State Historic Preservation Officer, Office of Cultural Development, Louisiana Department of Culture, Recreation & Tourism, Baton Rouge, Louisiana, to Niels Larsen, LA Department of Environmental Quality, Permits Application Administrative Review Group, Permit Support Services Division, Office of Environmental Services, Baton Rouge, Louisiana. Re: *Lake Charles Gasification Facility, Lake Charles Cogeneration, LLC, Agency Interest No. 160213, Activity No. PER20090001, Lake Charles, Calcasieu Parish, LA.*
- Karbula, James W., Ph.D. 2011. Letter dated October 25, 2011, from Dr. James W. Karbula, Regional Project Director, William Self Associates, Inc., Austin, Texas, to Patricia Mercado-Allinger, State Archaeologist, Archeology Division, Texas Historical Commission, Austin, Texas. Re: *Denbury Onshore, LLC, CO2 Sequestration Monitoring, Verification, and Accounting (MVA), Hastings Field, Brazoria County, Texas.*
- Maley, Donald W., Jr. 2008. Letter dated September 8, 2008, from Donald W. Maley, Jr., Vice President, Lake Charles Cogeneration, LLC, Houston, Texas, to Pam Breaux, State Historic Preservation Officer, State of Louisiana, Office of Cultural Development, Baton Rouge, Louisiana. Re: *Air Permit Application: Lake Charles Gasification Facility, Lake Charles Cogeneration, LLC, Lake Charles, Louisiana.*
- URS Corporation. 2012. *Lake Charles Cogeneration, LLC, Cultural Resources Assessment, Calcasieu Parish, Louisiana.* URS Job No. 10003620, July 2012.
- Watkins, Joel H. and Eugene M. Futato. 2011. *A Phase I Cultural Resources Survey of the Proposed Lake Charles Pipeline Lateral Project Located near Sulphur, Calcasieu Parish, Louisiana* (Draft Report). Prepared by The University of Alabama, Office of Archaeological Research, Moundville, Alabama. Prepared for CH2M HILL, Atlanta, Georgia.
- Wolfe, Mark. 2011. Letter dated November 1, 2011, from Mark Wolfe, State Historic Preservation Officer, Texas Historical Commission, Austin, Texas, to James Karbula, William Self Associates, Inc., Austin, Texas. Re: *Project Review under Section 106 of the National Historic Preservation act of 1966 and the Antiquities Code of Texas, Denbury Onshore, LLC, CO2 Sequestration, Monitoring, Verification, and Accounting (MVA), Hastings Field, Brazoria County, Texas.*
- Wolfe, Mark. 2012. Response dated September 7, 2012, from Mark Wolfe, State Historic Preservation Officer, Texas Historical Commission, Austin, Texas, to Pierina N. Fayish, NEPA Document Manager, National Energy Technology Laboratory, Department of Energy, Pittsburgh, Pennsylvania. Re: *Section 106 Consultation for Proposed Financial Assistance for the Lake Charles Carbon Capture and Sequestration (CCS) Project, Brazoria County, Texas (and Calcasieu Parish, Louisiana).*

Section 4.8 (Land Use)

CH2M Hill. 2010. Environmental Information Volume, Pipeline Lateral Lake Charles, Louisiana. Prepared for Denbury Onshore, Inc. March 2010.

_____. 2011. Lake Charles Pipeline Lateral Project Pre-Construction Notification (PCN) for Nationwide Permit 12. Prepared for Denbury Onshore, LLC. 5320 Legacy Drive, Plano, Texas 75024.

Section 4.9 (Socioeconomics and Environmental Justice)

Interstate Natural Gas Association of America (INGAA). 2001. Natural Gas Pipeline Impact Study. Available at: <http://www.ingaa.org/File.aspx?id=5597>. Allen, Williford & Seale Inc. Houston, Texas. Accessed on October 31, 2011.

Louisiana Tax Commission. 2009. Annual Report 2009. Available at: http://www.latax.state.la.us/Menu_AnnualReports/UploadedFiles/2009%20Annual%20Report.pdf. Accessed on October 31, 2011.

U.S. Census 2010. Profile of General Population and Housing Characteristics: 2010 (City of Sulphur, LA; Calcasieu Parish, LA; State of Louisiana; City of Alvin, TX; City of Pearland, TX; Brazoria County, TX; Jefferson County, TX; and State of Texas). Available at: <http://factfinder2.census.gov/main.html>. Accessed on October 29, 2011.

Section 4.10 – (Traffic and Transportation)

Transportation Research Board (TRB). 2010. *Highway Capacity Manual*. 5th Edition. The National Academy of Sciences. Washington D.C.

Section 4.11 (Noise)

ATCO Noise Management. (ATCO 2012). *Lake Charles Carbon Capture & Sequestration (CCS) Project Environmental Noise Survey & Noise Impact Assessment*. 2012. Prepared for Leucadia Energy, LLC. March 7, 2012.

Bies, D.A. and C.H. Hansen. 1988. *Engineering Noise Control*. Published by Unwin Hyman Ltd.

Federal Highway Administration (FHWA). 2006. *FHWA Highway Construction Noise Handbook*. U.S. Department of Transportation. August 2006.

Hoover & Keith, Inc. (H&K). 2012. *Acoustical Assessment of the Planned HDDs associated with the Lake Charles CO2 Pipeline Lateral Project for Denbury Onshore*. Prepared for CH2M Hill, Inc. March 14, 2012.

U.S. Department of Housing and Urban Development: HUD-953-CPD: *The Noise Guidebook*, September 1991.

U.S. Environmental Protection Agency (EPA). 1974. *Information on Levels of Environmental Noise Requisite to Protect Public Health and Welfare with an Adequate Margin of Safety*. March 1974.

Section 4.12 (Waste Management)

Denbury. 2008. *Waste Management/Minimization Plan*. Plano, Tx.

National Fire Protection Association. 2010. *Guide on Hazardous Materials*. 2010 Edition. Quincy, MA.

National Fire Protection Association. 2010. *Guide on Hazardous Materials*

National Fire Protection Association. 2012. *National Fire Protection Code 30: Flammable and Combustible Liquids Code*, 2012 Edition. Quincy, MA.

Section 4.13 (Materials)

None.

Section 4.14 (Human Health and Safety)

Occupational Safety and Health Administration, 1994, *Process Safety Management Guidelines for Compliance*, U.S. Department of Labor OSHA 3133, 1994 (Reprinted). Available at <http://www.osha.gov/Publications/osha3133.html>. Site accessed January 2013.

United States Department of Labor, Bureau of Labor Statistics (USBLS): *Injuries, Illnesses, and Fatalities*. Available at <http://www.bls.gov/iif/>. Site Accessed on January 2013.

Steve Walden Consulting and RDB Environmental Consulting. 2010. *Environmental Information Volume Part 4: CO₂ Sequestration Monitoring, Verification, and Accounting*. Hastings Oil Field, Texas. Prepared for Denbury Onshore, LLC.

Section 4.15 (Accident Analyses)

Agency for Toxic Substances and Disease Registry (ATSDR). 2004. [Toxicological Profile for Ammonia](#). U.S. Department of Health and Human Services, Public Health Service. Atlanta, GA

Atherton, W. 2005. *An Experimental Study in to Overtopping and Dynamic Pressures on a BundWall Post Catastrophic Failure of a Storage Vessel and Methods of Mitigation*. Health and Safety Executive Contract Research Report 333. Available online at: <http://www.hse.gov.uk/research/rrhtm/rr33.htm>. Accessed on February 4, 2013.

- Battelle, *Comparative Risks of Hazardous Materials and Non-Hazardous Materials Truck Shipment Accidents/Incidents Final Report*. Prepared for Federal Motor Carrier Safety Administration March 2001
- Deeb, R.A., T. L. Anderson, M.C. Kavanaugh, and L.A. Kell, 2013, Methanol: Fate and Transport in the Environment – Chapter 2, *in The Toxicology of Methanol*, John Wiley & Sons, Ltd., J.J. Clary (editor), 304 pp
- Denham, M. E., 1998, Fate of Isolated Spills on Savannah River Site Soils (U), Westinghouse Savannah River Company, WSRC-TR-98-00008, Rev. 1. April 1998.
- ENVIRON, 1996, Hazard Assessment for Human and Environmental Health: Methanol. Prepared for American Forest and Paper Association, Inc. Washington, D. C
- Intergovernmental Panel on Climate Change (IPCC). 2005. *Carbon Dioxide Capture and Storage*. Cambridge University Press. Canada.
- Jones, J.L. 2011., *Managing NH3 Risks: The Relative Magnitude of the Hazards for Different Transport Methods and Uses and Controls/Risk Mitigation Practices Training Course*: 13th California Unified Program Annual Training Conference Jan. 31 – Feb. 3, 2011 Garden Grove, CA.
- Lindberg, M.R. 2003. *Environmental Engineering Reference Manual*. 2nd ed. 23-8. Belmont, CA. Professional Publications, Inc.
- Malcolm Pirnie, Inc. 1999. *Evaluation of the Fate and Transport of Methanol in the Environment*. Oakland, CA. Prepared for American Methanol Institute, Washington, D.C.
- National Research Council. 1993. *Nutrient Requirements of Fish*. National Academy Press. Washington, D.C.
- Pipeline Hazardous Materials Safety Administration (PHMSA). 2013. Incident Data Base Based On Hazardous Materials Incidents. Available at <http://www.phmsa.dot.gov/hazmat/library/data-stats/incidents>. Accessed February 17, 2013
- PHMSA. 2011. Letter dated October 7, 2011, from Cynthia L Quaterman, Pipeline and Hazardous Materials safety Administration to Dr. Robin Pitblado, Director of ISA-1-SHE Risk Management Services, Der Norske Veritas, Katy, Texas Re: PHMSA Docket No. 2011-0075. Final decision for petition for approval of the PHAST-UDM Version 6.6 and 6.7 vapor gas dispersion models.

- Thyer, A.M., Hrist, I.L., and S. F. Jagger. 2002. Bund Overtopping – The Consequences of Catastrophic Tank Failure. *Journal of Loss Prevention in the Process Industries*. 15357-363.
- Thyer, A.M., Jagger, S.F., Atherton, W., and J.W. Ash. 2009. A Review of Catastrophic Failures of Bulk Liquid Storage Tanks. Institution of Chemical Engineers. *Loss Prevention Bulletin* 205 3-13.
- Trent, L.L, R.S. Hestand, III, and C.C. Carter, 1978, Toxicity of sulfuric acid to aquatic plants and organisms. *J. Aquat. Plant Manage.* 16:40-43.
- US Census Bureau, the 2012 Statistical Abstract, the National Data Book. Available at <http://www.census.gov/compendia/statab>. Accessed February 17, 2013.
- United States Department of Energy. 2012. W.A. Parish Post-Combustion CO2 Capture and Sequestration Project Draft Environmental Impact Statement Volume I September 2012 DOE/EIS-0473D
- United States Department of Energy. 2006. FutureGen Project Final Environmental Impact Statement DOE/EIS-0394
- U.S. Environmental Protection Agency (EPA). 2000. *Chemical accident risks in U.S. industry - A preliminary analysis of accident risk data from U.S. Hazardous chemical facilities*. James C. Belke. United States Environmental Protection Agency Chemical Emergency Preparedness and Prevention Office. September 25, 2000.

Section 4.16 (Impacts of No Action)

None.

Chapter 5: Potential Cumulative Effects

- Daniels, Gary. 2012. Hastings Oilfield, in *Handbook of Texas Online*. Published by the Texas State Historical Association. Available at: <http://www.tshaonline.org/handbook/online/articles/doh01>. Accessed on September 26, 2012).
- Denbury. 2012. *All Oil Companies Are Not Alike*. Denbury Corporate Presentation 2012.
- Energy Information Administration (EIA). 2009a. Electric Power Monthly, June 2009, with data through March 2009: Table 1.1, Net Generation by Energy Source: Total (All Sectors), 1995 through March 2009. Official Energy Statistics from the U.S. Government. Available at: <http://www.eia.gov/electricity/monthly/archive/pdf/02260906.pdf>. Accessed on February 6, 2013.

- Intergovernmental Panel on Climate Change (IPCC). 2007a. *Change 2007, The Physical Science Basis*. Contribution of Working Group I to the 4th Assessment Report of the IPCC. Solomon, S., Qin, D., Manning, M., Chen, Z., Marquis, M., Averyt, K.B., Tignor, M., and Miller, H.L., Editors. Cambridge University Press, Cambridge, United Kingdom, and New York, New York, USA.
- _____. 2007b. *Climate Change 2007: Synthesis Report*. Contribution of Working Groups I, II and III to the Fourth Assessment Report of the Intergovernmental Panel on Climate Change. Adopted section by section at IPCC Plenary XXVII (Valencia, Spain, 12-17 November 2007).
- Keeling, C.D., R.B. Bacastow, A.E. Bainbridge, C.A. Ekdahl, P.R. Guenther, and L.S. Waterman. 1976. Atmospheric Carbon Dioxide Variations at Mauna Loa Observatory, Hawaii. *Tellus*, 28(6):538-51.
- King, C., G. Gülen, J. Essandoh-Yeddu, and S. Hovorka. 2009. Economic analysis of an integrated anthropogenic carbon dioxide network for capture and enhanced oil recovery along the Texas Gulf Coast, Paper ES2009-90415, *Proceedings of the ASME 3rd International Conference on Energy Sustainability*, San Francisco, CA, July 19-23, 2009. GCCC Digital Publication Series No. 09-18.
- Louisiana Coastal Facts 2012 Louisiana Coastal Protection and Restoration Authority www.coastal.la.gov/index.cfm?md=pagebuilder...accessed January 10, 2012
- Massachusetts Institute of Technology (MIT). 2010. Role of Enhanced Oil Recovery in Accelerating the Deployment of Carbon Capture and Sequestration, an MIT Energy Initiative and Bureau of Economic Geology at UT Austin Symposium, July 23, 2010.
- National Energy Technology Laboratory (NETL). 2011. A Note on Sources of CO₂ Supply for Enhanced Oil Recovery Operations, Phil DiPietro and Peter Balash, National Energy Technology Laboratory, December 2011.
- National Oceanic and Atmospheric Administration (NOAA). 2013. Mauna Loa CO₂ Annual Mean. Available at: <http://www.esrl.noaa.gov/gmd/ccgg/trends/>. Accessed on February 6, 2013.
- National Research Council (NRC). 2012. *Induced Seismicity Potential in Energy Technologies*. Washington, DC: The National Academies Press. 300 pages.
- United States Environmental Protection Agency (EPA). 2012. Inventory of U.S. Greenhouse Gas Emissions and Sinks: 1990 – 2010. Washington, DC.
- United States Global Change Research Program (USGCRP). 2009. *Global Climate Change Impacts in the United States*. A State of Knowledge Report from the U.S. Global Research Program. Cambridge University Press, New York, NY.

United States Department of Energy. 2009. *Carbon Capture and Sequestration (via Enhanced Oil Recovery) from a Hydrogen Production Facility in an Oil Refinery Prepared for: U.S. Department of Energy National Energy Technology Laboratory Type of Report: Final Technical Report Reporting Period Start Date: November 16, 2009 Reporting Period End Date: June 16, 2010.* June 2010 DOE Award Number: DE-FE-0001871

Zhou, D., Meisong Yan, and W.M. Calvin. 2012. Optimization of a Mature CO₂ Flood - from Continuous Injection to WAG. Paper presented at the Society of Petroleum Engineers' Improved Oil Recovery Symposium, April 14-18, 2012, Tulsa, Oklahoma, USA.

Chapter 6: Applicable Regulatory Requirements and Permits

None.

Chapter 7: Irreversible and Irretrievable Commitment of Resources

None.

This page left blank intentionally.

9. Distribution List

U.S. Senate and House of Representatives Committees	
The Honorable Barbara Mikulski, Chairwoman Committee on Appropriations U. S. Senate S-128 The Capitol Washington, D.C. 20510	The Honorable Fred Upton, Chairman Committee on Energy and Commerce U.S. House of Representatives 2125 Rayburn House Office Building Washington, D.C. 20515
The Honorable Richard Shelby, Ranking Member Committee on Appropriations U. S. Senate S-128 The Capitol Washington, D.C. 20510-2402	The Honorable Henry A. Waxman, Ranking Member Committee on Energy and Commerce U.S. House of Representatives 2322A Rayburn House Office Building Washington, D.C. 20515-6143
The Honorable Dianne Feinstein, Chairwoman Committee on Appropriations, Subcommittee on Energy and Water Development U. S. Senate 184 Dirksen Senate Office Building Washington, D.C. 20510	The Honorable Harold Rogers, Chairman Committee on Appropriations U.S. House of Representatives H-307 The Capitol Washington, D.C. 20515
The Honorable Lamar Alexander, Ranking Member Committee on Appropriations, Subcommittee on Energy and Water Development U. S. Senate 188 Dirksen Senate Office Building Washington, D.C. 20510	The Honorable Nita Lowey, Ranking Member Committee on Appropriations U.S. House of Representatives 1016 Longworth House Office Building Washington, D.C. 20515
The Honorable Barbara Boxer, Chairwoman Committee on Environment and Public Works U. S. Senate 410 Dirksen Senate Office Building Washington, D.C. 20510-6176	The Honorable Rodney P. Frelinghuysen, Chairman Committee on Appropriations, Subcommittee on Energy and Water Development U.S. House of Representatives 2362-B Rayburn House Office Building Washington, D.C. 20515-3011

U.S. Senate and House of Representatives Committees	
<p>The Honorable David Vitter, Ranking Member Committee on Environment and Public Works U. S. Senate 703 Hart Senate Office Building Washington, D.C. 20510-6176</p>	<p>The Honorable Marcy Kaptur, Ranking Member Committee on Appropriations, Subcommittee on Energy and Water Development U.S. House of Representatives 2352-B Rayburn House Office Building Washington, D.C. 20515</p>
<p>The Honorable Ron Wyden, Chairman Committee on Energy and Natural Resources U. S. Senate 304 Dirksen Senate Office Building Washington, D.C. 20510</p>	<p>The Honorable Lisa Murkowski, Ranking Member Committee on Energy and Natural Resources U. S. Senate 304 Dirksen Senate Office Building Washington, D.C. 20510</p>

United States Senate	
Louisiana	
<p>The Honorable Mary Landrieu U. S. Senate 431 Dirksen Senate Office Building Washington, D.C. 20510</p>	<p>The Honorable David Vitter U. S. Senate 516 Hart Senate Office Building Washington, D.C. 20510</p>
Texas	
<p>The Honorable John Cornyn U. S. Senate 517 Hart Senate Office Building Washington, D.C. 20510</p>	<p>The Honorable Ted Cruz U. S. Senate Dirksen Senate Office Building Suite SDB-40B Washington, D.C. 20510</p>

United States House of Representatives	
<p>The Honorable Charles Boustany (Louisiana, 7th District) U.S. House of Representatives 1431 Longworth House Office Building Washington, DC 20515-1807</p>	<p>The Honorable Pete Olson (Texas, 22nd District) U.S. House of Representatives 312 Cannon House Office Building Washington, DC 20515</p>

State Governors	
The Honorable Bobby Jindal State of Louisiana Office of the Governor PO Box 94004 Baton Rouge, LA 70804	The Honorable Rick Perry State of Texas Office of the Governor 1100 San Jacinto Austin, Texas 78701

Local Agencies and Elected Representatives	
Louisiana	
Calcasieu Parish	
Mr. Bryan C. Beam Parish Administrator Parish Government Building 1015 Pithon Street, 2 nd Floor P.O. Box 1583 Lake Charles, LA 70602	Ms. Sandra Treme Police Juror District 11 920 Overton DeQuincy, LA 70633
Mr. Ray Taylor Police Juror District 12 2300 Currie Drive Sulphur, LA 70655	Mr. Francis Andrepont Police Juror District 13 1302 Fatima Sulphur, LA 70663
Mr. Les Farnum Police Juror District 15 312 Oakley Drive Sulphur, LA 70663	Mr. Wes Crain Director Calcasieu Parish Planning and Development Department Parish Government Building, 3 rd Floor 1015 Pithon Street P.O. Drawer 3287 Lake Charles, LA 70602
City of Sulphur	
Honorable Christopher Duncan, Mayor City of Sulphur 101 N. Huntington Street Sulphur, LA 70663	Mr. Dru Ellender City of Sulphur City Council – District 1 1100 E. Carlton Sulphur, LA 70663

Local Agencies and Elected Representatives	
<p>Mr. Mike W. Koonce City of Sulphur City Council – District 2 403 Navarre Street Sulphur, LA 70663</p>	<p>Ms. Veronica Allison City of Sulphur City Council – District 3 912 Elm Street Sulphur, LA 70663</p>
<p>Mr. Randy Favre City of Sulphur City Council – District 4 2011 Marge Street Sulphur, LA 70663</p>	<p>Mr. Stuart Moss City of Sulphur City Council – District 5 11 Mayflower Sulphur, LA 70663</p>
<p>Mr. John Bruce City of Sulphur Land Use Administrator 101 N. Huntington Street Sulphur, LA 70663</p>	
Texas	
Brazoria County	
<p>Mr. Dude Payne Brazoria County Commissioner, Pct. 1 111 East Locust Street Angleton, TX 77515</p>	<p>Mr. Matt Sebesta Brazoria County Commissioner, Pct. 2 111 East Locust Street Angleton, TX 77515</p>
<p>Ms. Stacy L. Adams Brazoria County Commissioner, Pct. 3 111 East Locust Street Angleton, TX 77515</p>	<p>Mr. Larry Stanley Brazoria County Commissioner, Pct. 4 111 East Locust Street Angleton, TX 77515</p>
<p>Mr. Gerald Roberts, PE Brazoria County County Engineer Engineering Department 451 N. Valasco, Suite 230 Angleton, TX 77515</p>	

Local Agencies and Elected Representatives	
City of Pearland	
Mr. Bill Eisen City Manager City of Pearland 3519 Liberty Drive Pearland, TX 77581	Mr. Tom Reid Mayor City of Pearland 3519 Liberty Drive Pearland, TX 77581
Ms. Susan Sherrouse Mayor Pro-Tem City of Pearland 3519 Liberty Drive Pearland, TX 77581	Mr. Woodrow "Woody" Owens Councilmember Position 1 City of Pearland 3519 Liberty Drive Pearland, TX 77581
Mr. Scott Shermant Councilmember Position 2 City of Pearland 3519 Liberty Drive Pearland, TX 77581	Mr. Keith Ordeneaux Councilmember Position 4 City of Pearland 3519 Liberty Drive Pearland, TX 77581
Mr. Greg Hill Councilmember Position 5 City of Pearland 3519 Liberty Drive Pearland, TX 77581	Mr. Harold Ellis City Planner Department of Planning City of Pearland 3519 Liberty Drive Pearland, TX 77581

Federal Agencies	
Advisory Council on Historic Preservation	
Mr. Reid Nelson Director, Office of Federal Agency Programs Advisory Council on Historic Preservation 1100 Pennsylvania Avenue, NW Old Post Office Building, RM 803 Washington, DC 20004	
Bureau of Indian Affairs	
Mr. Marv Keller Chief, Division of Environmental and Cultural Resource Management Bureau of Indian Affairs 2501 Mercator Drive Reston, VA 20191	
Council on Environmental Quality	
Mr. Horst Greczmiel Associate Director for NEPA Oversight Council on Environmental Quality 722 Jackson Place, Northwest Washington, DC 20503	
U.S. Army Corps of Engineers	
Mr. Pete Serio Chief, Regulatory Branch U.S. Army Corps of Engineers New Orleans District CEMVN-PM-RS P.O. Box 60267 New Orleans, LA 70160	Mr. Nathan Dayan Environmental Planning and Compliance U.S. Army Corps of Engineers New Orleans District CEMVN-PM-RS P.O. Box 60267 New Orleans, LA 70160
Ms. Linda C. LaBure Chief, Real Estate Division U.S. Army Corps of Engineers New Orleans District P.O. Box 60267 New Orleans, LA 70160-0267	Colonel Richard J. Muraski, Jr. District Commander U.S. Army Corps of Engineers Fort Worth District P.O. Box 17300 Fort Worth, TX 76102

Federal Agencies	
U.S. Department of Agriculture	
<p>Mr. John (Matthew) Harrington National Environmental Coordinator US Department of Agriculture National Resource Conservation Service Room 6151-1 P.O. Box 2890 Washington, DC 20013</p>	<p>Mr. Matthew Ponish US Department of Agriculture Farm Service Agency Mail Stop 0513, Room 4709 1400 Independence Ave-SW Washington, DC 20250</p>
<p>Mr. Kevin D. Norton Louisiana State Conservationist United States Department of Agriculture National Resources Conservation Service 3737 Government Street Alexandria, LA 71302</p>	<p>Mr. Salvador Salinas Texas State Conservationist United States Department of Agriculture National Resources Conservation Service 101 South Main Street Temple, TX 76501</p>
U.S. Department of the Interior	
<p>Mr. Willie R. Taylor Director Office of Environmental Policy and Compliance Department of the Interior 1849 C Street, NW, Mail Stop 2462 Washington, DC 20240</p>	<p>Ms. Pat Carter NEPA Coordinator Fish and Wildlife Services 4401 North Fairfax Drive MS-800 Arlington, VA 22203</p>
<p>Dr. Benjamin Tuggle Regional Director, Southwest Region U.S. Department of the Interior Fish and Wildlife Service P.O. Box 1306 Albuquerque, NM 87103-1306</p>	<p>Dr. Stephen Spencer Regional Environmental Officer Office of Environmental Policy and Compliance Albuquerque Region 1001 Indian School Road, NW, Suite 348 Albuquerque, New Mexico 87104</p>
<p>Ms. Cindy Dohner Regional Director, Southeast Region U.S. Department of the Interior Fish and Wildlife Service 1875 Century Blvd., Suite 400 Atlanta, GA 30345</p>	<p>Mr. Brad Rieck Supervisor, Lafayette Field Office U.S. Department of the Interior Fish and Wildlife Service 646 Cajundome Blvd., Suite 400 Lafayette, LA 70506-4290</p>

Federal Agencies	
<p>Mr. Steve Parris Supervisor, Clear Lake Field Office U.S. Department of the Interior Fish and Wildlife Service 17629 El Camino Real, Suite 211 Houston, TX 77058</p>	
U.S. Department of Transportation	
<p>Ms. Camille Mittelholtz Deputy Director, Office of Safety, Energy and Environment Office of Transportation Policy Department of Transportation 1200 New Jersey Avenue, SE Washington, DC 20590-0001</p>	<p>Dr. Magdy El-Sibaie Associate Administrator Pipeline and Hazardous Materials Safety Department of Transportation 1200 New Jersey Ave, SE Washington, DC 20590-0001</p>
<p>Mr. Carl Bausch Office of Human and Natural Environment Federal Transit Administration Department of Transportation 1200 New Jersey Avenue, SE Washington, DC 20390-0001</p>	
U.S. Environmental Protection Agency	
<p>Mr. Michael P. Jansky Regional Environmental Review Coordinator U.S. Environmental Protection Agency, Region 6 1445 Ross Ave., Mail Code 6EN-XP Dallas, TX 75202-2733</p>	<p>Ms. Susan Bromm Director, Office of Federal Activities U.S. Environmental Protection Agency Mail Code 2251-A 1200 Pennsylvania Avenue, NW Washington, DC 20460</p>
<p>Ms. Rhonda Smith NEPA Coordinator U. S. Environmental Protection Agency Region 6 1445 Ross Avenue Dallas, TX 75202</p>	

Native American Tribes	
<p>Mr. Carlos Bullock Chairman Alabama Coushatta Tribe of Texas 571 State Park Road 56 Livingston, TX 77351</p>	<p>Mr. John Paul Darden Chairman Chitimacha Tribe of Louisiana P.O. Box 661 Charenton, LA 70523</p>
<p>Mr. Kevin Sickey Chairman Coushatta Tribe of Louisiana P.O. Box 818 Elton, LA 70532</p>	<p>B. Cheryl Smith Principal Chief Jena Band of Choctaw Indians P.O. Box 14 Jena, LA 71342</p>
<p>Mr. Earl Barbry, Sr. Chairman Tunica-Biloxi Tribe of Louisiana P.O. Box 1589 Marksville, LA 71351</p>	<p>Brenda Edwards Chairman Caddo Nation P.O. Box 487 Binger, OK 73009</p>
<p>Phyliss J. Anderson Chief Mississippi Band of Choctaw Indians P.O. Box 6010 Choctaw Branch Choctaw, MS 39350</p>	<p>Mr. John Berrey Chair Quapaw Tribe of Oklahoma P.O. Box 765 Quapaw, OK 74363</p>
<p>Mr. Gregory E. Pyle Chief Choctaw Nation of Oklahoma P.O. Box 1210 Durant, OK 74702</p>	<p>Mr. Leonard M. Harjo Principal Chief Seminole Nation of Oklahoma P.O. Box 1498 Wewoka, OK 74884</p>
<p>Mr. James E. Billie Chairman Seminole Tribe of Florida 6300 Stirling Road Hollywood, FL 33024</p>	<p>Mr. Juan Garza, Jr. Chairman Kickapoo Traditional Tribe of Texas HC 1, Box 9700 Eagle Pass, TX 78852</p>
<p>Mr. Frank Paiz Governor Ysleta Del Sur Pueblo of Texas P.O. Box 17579 – Ysleta Station El Paso, TX 79917</p>	

State Agencies	
Louisiana	
<p>Ms. Peggy Hatch Office of the Secretary Louisiana Department of Environmental Quality P.O. Box 4301 Baton Rouge, LA 70821-4301</p>	<p>Mr. Robert Barham Office of the Secretary Louisiana Department of Fish and Game 2000 Quail Drive Baton Rouge, La 70808</p>
<p>Ms. Sherri LeBas Office of the Secretary Louisiana Department of Transportation and Development P.O. Box 94245 1201 Capitol Access Road Baton Rouge, LA 70804-9245</p>	<p>Mr. Mike Strain Commissioner Louisiana Department of Agriculture and Forestry P.O. Box 631 Baton Rouge, LA 70821</p>
<p>Ms. Pam Breaux State Historic Preservation Officer Department of Culture, Recreation & Tourism Office of Cultural Development P.O. Box 44247 Baton Rouge, LA 70804-4247</p>	
Texas	
<p>Ms. Denise Stines Francis State Single Point of Contact Governor's Office of Budget, Planning and Policy P.O. Box 12428 Austin, TX 78711</p>	<p>Mr. Toby Baker Governor's Advisor – Natural Resources and Agriculture P.O. Box 12428 Austin, TX 78711</p>
<p>Mr. Terry Zrubek Governor's Advisor – Water P.O. Box 12428 Austin, TX 78711</p>	<p>Mr. Mark Wolfe State Historic Preservation Officer Texas Historical Commission P.O. Box 12276 Austin, TX 78711</p>
<p>Ms. Sandra Pollan Brazoria County Historical Commission 109 Lazy Lane Lake Jackson, TX 77566</p>	

Organizations	
Mr. Kenneth Nemeth Executive Director Southern States Energy Board 6325 Amherst Court Norcross, GA 30092	Mr. Richard Liebert Chairman Citizens for Clean Energy, Inc. 3417 Fourth Avenue, South Great Falls, MT 59405
Ms. Kassie Seigal Air and Climate Energy Center for Biological Diversity P.O. Box 549 Joshua Tree, CA 92252	Ms. Vicki Patten General Counsel Environmental Defense Fund 2334 North Broadway Boulder, Co 80304
Mr. Seth Kirshenbug Executive Director Energy Communities Alliance 1101 Connecticut Ave – NW Suite1000 Washington, DC 20036	Mr. Ed Hopkins Seirra Club, Washington DC Office 408 C Street, NE Washington, DC 20001
Ms. Michelle Scott Vice President and General Counsel National Audubon Society 225 Varick Road, 7 th Floor New York, NY 10014	Ms. Elizabeth Merritt Deputy General Counsel National Trust for Historic Preservation 1785 Massachusetts Avenue, NW Washington, DC 20036
Mr. Jim Lyon VP for Conservation National Wildlife Federation 901 E Street, NW Suite 400 Washington, DC 20004	Mr. David Goldstein Energy Program Director National Resource Defense Council 111 Sutter Street, 20 th Floor San Francisco, CA 94104
Mr. David Hawkins Director, Climate Programs National Resource Defense Council 1200 New York Avenue, NW Suite 400 Washington, DC 20005	Mr. Jimmie Powell Director of Federal Programs The Nature Conservancy 4245 North Fairfax Drive Arlington, VA 22203

Organizations	
Ms. Denali Daniels Energy Senior Program Manager Denali Commission 510 L Street, Suite 410 Anchorage, AK 99501	Dr. Mildred McClain Executive Director Harambee House, Inc. Citizens for Environmental Justice 1115 Habersham Street Savannah, GA 31401
Mr. Paul Schwartz National Policy Coordinator Clean Water Action 1010 Vermont Avenue, NW Suite 1100 Washington, DC 20005	Mr. Ted Venker National Communications Director Coastal Conservation Association 6919 Portwest Drive, Suite 100 Houston, TX 77024
Mr. Barry Worthington United States Energy Association 1300 Pennsylvania Ave, NW Suite 550, MB 142 Washington, DC 20004	Ms. Donna Richard President Calcasieu Historical Preservation Society P.O. Box 1214 Lake Charles, LA 70602
Ms. Susan Reed Executive Director Imperial Calcasieu Museum 204 Sallier Street Lake Charles, LA 70602	Ms. Debbie Johnson-Houston Director McNesse Library Archives and Special Collection Department 4205 Ryan Street Lake Charles, LA 70602
Ms. Jackie Haynes Executive Director Brazoria County Historical Museum 100 E. Cedar Street Angleton, TX 77515	Ms. Violet Lehrer Sierra Club 50 F Street, NW, Eighth Floor Washington, DC 20001

Libraries	
Andrew Fearn Branch Librarian Pearland Library 3522 Liberty Drive Pearland, TX 77581	Esther Pennington Branch Manager Sulphur Regional Library 1160 Cypress Street Sulphur, LA 70663
Kathy Jones Branch Manager Westlake Library 937 Mulberry Street Westlake, LA 70669	Esther Pennington Branch Manager Maplewood Library 91 Center Circle Sulphur, LA 70663

This page left blank intentionally.

10. List of Preparers

U.S. Department of Energy

Pierina Fayish, NEPA Document Manager
Environmental Compliance Division, National Energy Technology Laboratory

Richard A. Hargis, Jr.
Environmental Compliance Division, National Energy Technology Laboratory

Mark M. McKoy
Environmental Compliance Division, National Energy Technology Laboratory

Gregory O'Neil
Major Projects Division, National Energy Technology Laboratory

Ecology and Environment, Inc.

George Rusk J.D., V.P., Program Manager
J.D., 1977, Juris Doctor, State University of New York at Buffalo
B.A., 1973, Political Science, Yale University
36 years' experience in environmental consulting and environmental impact assessment with extensive practice in environmental law.

Janine Whitken, Project Manager
B.E., 1984, Engineering, Stevens Institute of Technology
28 years' experience planning and managing environmental analyses and approvals for complex energy projects; provided expert witness testimony on permitting of power plants.

David Beeson P.G., Geologist: Geology and Soils
M.S. 1988, Geology, University of Texas at Arlington
B.S. 1982, Geology, University of Texas at Arlington
B.S. 1982, Biology, University of Texas B.S. Arlington
24 years' experience in preparation of EISs/EAs and geotechnical, geophysical, and hydrogeologic investigations.

Joanna Christopher, Chemist: Proposed Action and Alternatives
B.S., Chemistry, Canisius College
A.S., Liberal Arts/Science, Erie Community College
32 years' experience in chemical analysis and interpretation, and managing surface water and groundwater monitoring programs and site investigations.

Georganna Collins R.L.A., Architect/Engineer: Surface Water, Groundwater, Biology
B.S., 1978, Landscape Architecture, Texas A&M University
M.S., 1983, Landscape Architecture, Texas A&M University
B.S., 1984, Mining Engineering, Texas A&M University
34 years' experience in ecological and landscape architecture focusing on habitat assessment, biological surveys and river, stream, and wetland restoration.

Louise Flynn, Public Health Specialist: Accident Analysis
M.P.H., Public Health, Johns Hopkins Bloomberg School of Public Health
M.E.S., Environmental Studies, Yale School of Forestry and Environmental Studies
B.A., Biology and Society, Cornell University
26 years' experience in human health and safety and hazardous materials assessment and management for EISs/EAs and feasibility studies.

Jacquelyn Gillings, Assistant Project Manager: Proposed Action and Alternatives
M.S., Health Physics, University of Florida
B.A., Physics, University of New York College at Geneseo
36 years' experience in environmental consulting and project management, including EISs/EAs, regulatory compliance, and health physics.

Komi Hassan, Assistant Project Manager: Traffic and Transportation, and Wastes and Materials; Pipeline Task Manager
M.S., 2009, Marine/Environmental Biology, Nicholls State University
B.S., 2003, Biological Engineering, Louisiana State University
Eight years' experience in environmental consulting, including EISs/EAs, regulatory compliance and permitting.

Paul Jonmaire, Ph.D, Toxicologist: Human Health and Safety
Ph.D., Environmental Health, University of Cincinnati College of Medicine
B.A., Biology, Canisius College
35 years' experience in directing worker health and safety programs, medical monitoring, respiratory protection, and risk assessment activities.

Eric Lindeman, Emergency Response Specialist: Accident Analysis
B.A., History and Secondary Education, Park College
20 years' experience in emergency response field operations and safety training, site investigations, and cleanup monitoring.

Kristine Lloyd, Environmental Scientist: Wastes and Materials, Traffic and Transportation
B.S., Biology, Texas Christian University
25 years' experience in the investigation and remediation of sites containing hazardous materials and waste, and preparation of EISs/EAs.

George Lukert, P.G., Geologist: Geology and Soils

M.S., Geology, University of Idaho at Moscow

B.S., Geology, Edinboro University of Pennsylvania

22 years' experience in petroleum and hazardous waste investigations, regulatory compliance, and remedial system design and installation. Expert in geologic sequestration.

James Petersen, P.E., Civil Engineer: Wastes and Materials and Accident Analysis

B.S., Engineering Science, Montana Tech of University of Montana

21 years' experience in civil engineering focusing on remedial investigations/feasibility studies; hazardous material and waste; pollution control systems and remedial alternatives.

Gerardo R. De La Pena, P.G., Geoscientist: Geology and Soils, Cumulative Impacts, Accident Analysis, CCS Task Manager

B.S. Geology, George Washington University

M.S. Geology, Colorado School of Mines

15 years' experience in preparing EISs/EAs and geologic resource assessments and geologic impact evaluations.

Christine Reguera, Environmental Planner: Land Use

M.S., 1997, Community/Regional Planning, University of Texas

B.S., 1994, Environmental Design, Texas A&M University

17 years' experience in environmental planning and community development, including environmental assessment, land use inventories and evaluation, and land use compatibility studies.

Kirsten Shelly, Economist: Socioeconomics and Environmental Justice

M.S., 1991, Environmental/Resource Economics, University of London

B.A., 1989, Economics, Colgate University

23 years' experience in environmental economic analysis, social impact assessment, socioeconomic and econometric modeling, and preparation of EISs/EAs.

Thomas Siener, CIH, Industrial Hygienist: Noise

B.S., 1971, Biology, Purdue University

39 years' experience managing air and noise monitoring and modeling projects and developing EISs/EAs for energy projects.

Rachel Smith, Environmental Scientist: Environmental Justice

B.A., Environmental Studies/ Chemistry, State University of New York at Buffalo

10 years' experience preparing EISs/EAs, and supporting urban and residential development projects and public participation programs.

Natasha Snyder, Anthropologist: Cultural Resources

M.A., 2009, Anthropology, State University of New York at Buffalo

B.A., 1997, Anthropology/Environment Science, State University of New York at Buffalo

27 years' experience in NHPA Section 106 compliance; Phase I surveys, Phase II testing, and Phase III data recovery/mitigation planning for archaeological and cultural resources.

Carl Stineman, Biochemist: Human Health and Safety, Accident Analysis

B.S., Chemistry, Philadelphia College of Pharmacy and Science

Ph.D., Biochemistry, State University of New York at Buffalo

Postdoctoral Studies, Pharmaceuticals, State University of New York at Buffalo

34 years' experience in environmentally related toxicological evaluation, specializing in assessment of human health risks from exposure to environmental contaminants.

David L. Trimm, C.F.P., Ecologist: Accident Analysis

M.S., Invertebrate Zoology/Marine Biology, Southwest Texas State University

B.S., Aquatic Biology/Chemistry, Southwest Texas State University

34 years' experience evaluating ecotoxicological impacts in terrestrial, aquatic, and marine organisms in the preparation of EISs, ecological risk assessments, and natural resource damage assessments.

Bruce Wattle, QEP, CCM, Air Quality Specialist: Climate and Air Quality

B.S., 1979, Atmospheric Science, University of Michigan

32 years' experience preparing EISs and air permit applications, conducting meteorological and dispersion modeling studies, and leading regulatory compliance and air emission projects.