

THE LOS ALAMOS NATIONAL LABORATORY SITE-WIDE ENVIRONMENTAL IMPACT STATEMENT PROCESS

The United States Department of Energy (DOE) has a policy (10 Code of Federal Regulations [CFR] 1021.330) of preparing a Site-Wide Environmental Impact Statement (SWEIS) for certain large, multiple-facility sites, such as the Los Alamos National Laboratory (LANL). The purpose of a SWEIS is to provide DOE and its stakeholders with an analysis of the environmental impacts resulting from ongoing and reasonably foreseeable new operations and facilities and reasonable alternatives at the DOE site. The SWEIS analyzes four alternatives for the continued operation of LANL to identify the potential effects that each alternative could have on the human environment.

The SWEIS Advance Notice of Intent, published in the *Federal Register* (FR) on August 10, 1994 (59 FR 40889), identified possible issues and alternatives to be analyzed. Based on public input received during prescoping, DOE published the Notice of Intent to prepare the SWEIS in the *Federal Register* on May 12, 1995 (60 FR 25697). DOE held a series of public meetings during prescoping and scoping to provide opportunities for stakeholders to identify the issues, environmental concerns, and alternatives that should be analyzed in the SWEIS. An Implementation Plan¹ was published in November 1995 to summarize the results of scoping, describe the scope of the SWEIS based on the scoping process, and present an outline for the draft SWEIS. The Implementation Plan also included a discussion of the issues reflected in public comments during scoping.

In addition to the required meetings and documents described above, the SWEIS process has included a number of other activities intended to enhance public participation in this effort. These activities have included:

- Workshops to develop the Greener Alternative described and analyzed in the SWEIS.
- Meetings with and briefings to representatives of federal, state, tribal, and local governments during prescoping, scoping, and preparation of the draft SWEIS.
- Preparation and submission to the Los Alamos Community Outreach Center of information requested by members of the public related to LANL operations and proposed projects.
- Numerous Open Forum public meetings in the communities around LANL to discuss LANL activities, the status of the SWEIS, and other issues raised by the public.

The draft SWEIS was distributed to interested stakeholders for comment. The comment period extended from May 15, 1998, to July 15, 1998. Public hearings on the draft SWEIS were announced in the *Federal Register*, as well as community newspapers and radio broadcasts. Public hearings were held in Los Alamos, Santa Fe, and Española, New Mexico, on June 9, 1998, June 10, 1998, and June 24, 1998, respectively.

Oral and written comments were accepted during the 60-day comment period for the draft SWEIS. All comments received, whether orally or in writing, were considered in preparation of the final SWEIS. The final SWEIS includes a new volume IV with responses to individual comments and a discussion of general major issues. DOE will prepare a Record of Decision no sooner than 30 days after the final SWEIS Notice of Availability is published in the *Federal Register*. The Record of Decision will describe the rationale used for DOE's selection of an alternative or portions of the alternatives. Following the issuance of the Record of Decision, a Mitigation Action Plan may also be issued to describe any mitigation measures that DOE commits to in concert with its decision.

¹ DOE *National Environmental Policy Act* regulations (10 CFR 1021) previously required that an implementation plan be prepared; a regulation change (61 FR 64604) deleted this requirement. An implementation plan was prepared for this SWEIS.

COVER SHEET

Responsible Agency: U.S. Department of Energy (DOE)

Cooperating Agency: Incorporated County of Los Alamos

Title: Site-Wide Environmental Impact Statement for the Continued Operation of the Los Alamos National Laboratory, Los Alamos, New Mexico (DOE/EIS-0238)

Contact: For further information concerning this Site-Wide Environmental Impact Statement (SWEIS), contact:

Corey Cruz, Project Manager
U.S. DOE, Albuquerque Operations Office
P.O. Box 5400, Albuquerque, NM 87185
Telephone: 505-845-4282 Fax: 505-845-6392

For general information on DOE's *National Environmental Policy Act* (NEPA) process, contact:

Carol Borgstrom, Director
Office of NEPA Policy and Assistance (EH-42)
U.S. DOE, 1000 Independence Avenue, SW, Washington, DC 20585
Telephone: 202-586-4600 or leave a message at 1-800-472-2756

Abstract: DOE proposes to continue operating the Los Alamos National Laboratory (LANL) located in Los Alamos County, in north-central New Mexico. DOE has identified and assessed four alternatives for the operation of LANL: (1) No Action, (2) Expanded Operations, (3) Reduced Operations, and (4) Greener. Expanded Operations is DOE's Preferred Alternative, with the exception that DOE would only implement pit manufacturing at a level of 20 pits per year. In the No Action Alternative, DOE would continue the historical mission support activities LANL has conducted at planned operational levels. In the Expanded Operations Alternative, DOE would operate LANL at the highest levels of activity currently foreseeable, including full implementation of the mission assignments from recent programmatic documents. Under the Reduced Operations Alternative, DOE would operate LANL at the minimum levels of activity necessary to maintain the capabilities to support the DOE mission in the near term. Under the Greener Alternative, DOE would operate LANL to maximize operations in support of nonproliferation, basic science, materials science, and other nonweapons areas, while minimizing weapons activities. Under all of the alternatives, the affected environment is primarily within 50 miles (80 kilometers) of LANL. Analyses indicate little difference in the environmental impacts among alternatives. The primary discriminators are: collective worker risk due to radiation exposure, socioeconomic effects due to LANL employment changes, and electrical power demand.

Public Comment and DOE Decision: The draft SWEIS was released to the public for review and comment on May 15, 1998. The comment period extended until July 15, 1998, although late comments were accepted to the extent practicable. All comments received were considered in preparation of the final SWEIS¹. DOE will utilize the analysis in this final SWEIS and prepare a Record of Decision on the level of continued operation of LANL. This decision will be no sooner than 30 days after the Notice of Availability of the final SWEIS is published in the *Federal Register*.

¹ Changes made to this SWEIS since publication of the draft SWEIS are marked with a vertical bar to the right or left of the text.

TABLE OF CONTENTS

Table of Contents	i
List of Figures	xv
List of Tables	xix
Abbreviations and Acronyms	xlvi
Measurements and Conversions	lvii
Index	lxiii

APPENDIX A WATER RESOURCES A-1

A.1 SURFACE WATER NATIONAL POLLUTANT DISCHARGE ELIMINATION SYSTEM VOLUMES	A-1
A.2 GROUNDWATER HYDRAULIC PROPERTIES	A-1
A.3 MAIN AQUIFER VOLUME ESTIMATES	A-1
A.4 DEVELOPMENT OF GROUNDWATER MODEL INPUT FILES	A-11
A.4.1 Water Use Projections	A-11
A.4.2 Other Input Files and Information	A-14
A.5 MODEL RESULTS	A-14
A.5.1 Changes in Water Levels and Storage in the Main Aquifer	A-15
A.6 MODEL UNCERTAINTIES AND LIMITATIONS	A-16
REFERENCES	A-17

APPENDIX B AIR QUALITY B-1

B.1 RADIOLOGICAL AIR QUALITY	B-1
B.1.1 Methodology	B-1
B.1.1.1 Modeled Facilities	B-1
B.1.1.2 Selection of the CAP-88 Model	B-4
B.1.1.3 Limitations of the CAP-88 Model	B-5
B.1.1.4 Model Input Parameters	B-5
B.1.1.5 Facility-Specific Maximally Exposed Individual Doses	B-17
B.1.1.6 LANL Site-Wide Maximally Exposed Individual Dose	B-20
B.1.1.7 Population Dose	B-20

B.1.1.8	Isodose Maps	B-21
B.1.2	Results of Consequence Analyses	B-21
B.1.2.1	Doses to Facility-Specific Maximally Exposed Individuals	B-21
B.1.2.2	Dose to the LANL Site-Wide Maximally Exposed Individual	B-21
B.1.2.3	Collective Population Dose	B-27
B.1.2.4	Isodose Maps	B-28
B.1.2.5	Uncertainties	B-28
B.2	NONRADIOLOGICAL AIR QUALITY	B-38
B.2.1	Assumptions, Data Sources, Standards, and Models	B-38
B.2.1.1	Applicable Guidelines/Standards and Emission Sources	B-38
B.2.1.2	Receptors and Receptor Sets	B-39
B.2.1.3	Air Quality Dispersion Models	B-40
B.2.2	Criteria Pollutants—General Approach	B-41
B.2.2.1	Criteria Pollutants—Methodology	B-41
B.2.2.2	Results of Criteria Pollutant Analysis	B-41
B.2.3	Toxic Air Pollutants—General Approach	B-41
B.2.3.1	Toxic Pollutants— Methodology for Individual Pollutants	B-42
B.2.3.2	Results of the Toxic Pollutant Analysis— Individual Pollutants	B-46
B.2.3.3	Toxic Pollutants— Methodology for Combined Impacts Analyses	B-47
B.2.3.4	Toxic Pollutants—Results of Combined Impact Analysis	B-47
Attachment 1	Analysis of Criteria Pollutants from Combustion Sources	B-49
Attachment 2	Toxic Chemicals Considered for the Analysis	B-63
Attachment 3	Set of Sensitive Receptors for Nonradiological Air Quality Analysis	B-71
Attachment 4	Dispersion Modeling Methodology used to Develop Screening Level Emission Values	B-75
Attachment 5	Eight-Hour Screening Level Emission Values (Table 1) and Annual Screening Level Emission Values for Chemicals (Table 2) TA-3 Example Worksheets	B-79
Attachment 6	Additive Impact Analysis Associated with the Combined Releases of Carcinogenic Pollutants from all Technical Areas	B-143
Attachment 7	Air Quality Impact Assessment of the TA-3 Chemical and Metallurgy Research Facility (CMR) Methylene Chloride Emissions	B-183

Attachment 8
Air Quality Impact Assessment of the TA-3 Beryllium EmissionsB-185

Attachment 9
Air Quality Impact Assessment of the TA-3 Shops Complex
Nickel Dust EmissionsB-189

Attachment 10
Air Quality Impact Assessment of Paint Booth EmissionsB-191

Attachment 11
Air Quality Impact Assessment of Incinerator EmissionsB-203

Attachment 12
Air Quality Impact Assessment of Open Burning Operations
at High Explosives Treatment and Disposal Facility.B-215

Attachment 13
Air Quality Impact Assessment of Emissions from Firing Sites.....B-229

Attachment 14
Air Quality Impact Assessment of the Health Research Laboratory
(TA-43) EmissionsB-239

Attachment 15
Air Quality Impact Assessment of the TA-53 Chloroform EmissionsB-243

Attachment 16
Air Quality Impact Assessment of the TA-55 Beryllium EmissionsB-245

Attachment 17
Air Quality Impact Assessment of the TA-55 Hydrochloric and
Nitric Acid EmissionsB-247

Attachment 18
Air Quality Impact Assessment of the TA-59 Hydrochloric and
Nitric Acids EmissionsB-251

Attachment 19
Air Quality Impact Assessment of the TA-53 Ozone EmissionsB-255

REFERENCESB-259

APPENDIX C
CONTAMINANT DATA SETS SUPPORTING ECOLOGICAL AND
HUMAN HEALTH CONSEQUENCE ANALYSISC-1

REFERENCESC-164

APPENDIX D**HUMAN HEALTH.....D-1**

D.1	PUBLIC HEALTH CONSEQUENCES: PRIMER AND RECENT STUDIES NEAR LANL.....	D-1
D.1.1	Primer on Human Health Consequences of Radiological and Chemical Exposures	D-1
D.1.1.1	About Radiation and Radioactivity	D-1
D.1.1.2	About Radiation and the Human Body	D-4
D.1.1.3	About Radioactive Material Within the Body	D-6
D.1.1.4	About the Material of Interest at LANL	D-7
D.1.1.5	How DOE Regulates Radiation and Radioactive Material	D-8
D.1.1.6	About Chemicals and Human Health	D-8
D.1.1.7	How Toxic Chemicals Affect the Body.....	D-9
D.1.1.8	About Chemical Carcinogens	D-10
D.1.1.9	Radionuclides and Chemicals of Interest at LANL.....	D-11
D.1.2	Supplemental Information on Public Health: U.S., New Mexico, and the Local LANL Community.....	D-11
D.1.2.1	Public Health: United States	D-12
D.1.2.2	Comparison of Cancer Mortalities Between the U.S. and New Mexico.....	D-14
D.1.2.3	Cancer Incidence and Mortality Among Ethnic Groups Relevant to the LANL Area	D-16
D.1.2.4	Supplemental Information on Recent Studies of Los Alamos County Cancer	D-16
D.2	METHODS USED FOR THE ESTIMATION OF HUMAN HEALTH CONSEQUENCES OF CONTINUED LANL OPERATIONS	D-28
D.2.1	Methods Used to Evaluate Public Health Consequences from Routine Operations	D-28
D.2.1.1	Methods for Evaluation for External Radiation Risk and Inhalation Dose/Risk from Airborne Radionuclides and Chemicals	D-28
D.2.1.2	Methods for Estimation of Ingestion Risks from Radionuclides and Chemicals	D-29
D.2.2	Worker Health	D-32
D.2.2.1	Radiological Consequences to Workers	D-33
D.2.2.2	Nonionizing Radiation Consequences to Humans and Other Biota.....	D-36
D.2.2.3	Chemical Exposures Consequences to Workers	D-36
D.2.2.4	Worker Physical Safety Consequences	D-39

D.3 ANALYSIS OF POTENTIAL PUBLIC HUMAN HEALTH CONSEQUENCES DUE TO THE CONTINUED OPERATION OF LANLD-40

D.3.1 Public Health Consequence AnalysisD-40

 D.3.1.1 Inhalation Radiological Doses Estimated to the Public from LANL and Specific Key Facilities Under the Four Alternatives for Continued OperationsD-40

 D.3.1.2 Public Radiological Doses from Ingestion for all Four AlternativesD-42

D.3.2 Analysis of Public Health Consequences from High Explosives Testing Site Chemical EmissionsD-42

D.3.3 Estimates of Dose and Risk from Radiological and Metallic Contaminants Potentially Ingested by Residents, Recreational Users of LANL Lands, and via Special Pathways.D-45

 D.3.3.1 Potential Exposures to Tritium via Los Alamos CanyonD-45

 D.3.3.2 Mortandad CanyonD-46

D.3.4 Comparison of Concentrations of Selected Radionuclides and Metals in Regional and LANL Perimeter/On-Site Samples of Environmental MediaD-138

 D.3.4.1 ArsenicD-138

 D.3.4.2 BerylliumD-141

 D.3.4.3 LeadD-141

D.3.5 Data Used in the Human Health AnalysisD-143

REFERENCESD-170

APPENDIX E
CULTURAL RESOURCES E-1

E.1 OVERVIEWE-1

E.2 PREVIOUS STUDY OF CULTURAL RESOURCES IN THE LANL REGION..... E-1

 E.2.1 Studies of Prehistoric ResourcesE-1

 E.2.2 Studies of Historic Resources at LANLE-2

 E.2.3 Studies of Traditional Cultural PropertiesE-3

E.3 CULTURAL BACKGROUND OF THE LANL REGIONE-5

 E.3.1 Prehistoric Background of the LANL RegionE-5

 E.3.1.1 Paleo-Indian Period (10,000 Through 4000 B.C.).....E-5

 E.3.1.2 Archaic Period (4000 B.C. Through A.D. 600).....E-5

 E.3.1.3 Developmental Period (A.D. 600 Through 1100).....E-6

 E.3.1.4 Coalition Period (A.D. 1100 Through 1325).....E-7

 E.3.1.5 Classic Period (A.D. 1325 Through 1600)E-7

E.3.2	Historic Background of the LANL Region	E-7
E.3.2.1	Spanish Colonial Period (A.D. 1600 Through 1849)	E-7
E.3.2.2	Early U.S. Territorial/Statehood Period (A.D. 1849 Through 1942)	E-8
E.3.2.3	Nuclear Energy Period (A.D. 1943 to Present)	E-9
E.3.3	Traditional Cultural Background in the LANL Region.	E-11
E.3.3.1	American Indian Cultures in the LANL Region	E-12
E.3.3.2	Traditional Hispanic Communities in the LANL Region	E-13
E.3.3.3	Traditional Cultural Property Categories.	E-14
E.3.3.4	Traditional Subsistence Features	E-19
E.4	FEDERAL AND STATE REGULATIONS RELATED TO CULTURAL RESOURCES AT LANL	E-21
E.5	RESEARCH METHODOLOGY	E-25
E.5.1	Research Methods for Acquiring Data on Prehistoric Cultural Resources	E-26
E.5.2	Research Methods for Acquiring Data on Historic Cultural Resources.	E-27
E.5.3	Research Methods for Acquiring Data on Traditional Cultural Properties	E-27
E.5.4	Impacts Analysis Methods.	E-29
E.6	EXISTING CONDITIONS FOR CULTURAL RESOURCES AT LANL	E-30
E.6.1	Cultural Resource Management at LANL.	E-30
E.6.2	Prehistoric Resources Within LANL Boundaries	E-39
E.6.3	Historic Cultural Resources Within LANL Boundaries	E-40
E.6.4	Traditional Cultural Properties in the LANL Region	E-40
E.6.4.1	Ceremonial Sites	E-42
E.6.4.2	Natural Features.	E-44
E.6.4.3	Ethnobotanical Gathering Sites	E-44
E.6.4.4	Artisan Material Gathering Sites	E-45
E.6.4.5	Traditional Subsistence Features	E-46
	REFERENCES	E-47

APPENDIX F
TRANSPORTATION RISK ANALYSIS F-1

F.1	INTRODUCTION.	F-1
F.1.1	Purpose of the Analysis	F-1
F.1.2	Scope of the Analysis	F-1
F.2	PACKAGING OVERVIEW.	F-2
F.2.1	Limited Quantity Packaging	F-3

F.2.2	Industrial Packaging	F-3
F.2.3	Type A	F-5
F.2.4	Type B	F-5
F.2.4.1	FL-Type Container	F-5
F.2.4.2	Transuranic Packaging Transporter for Contact-Handled Transuranic Waste	F-5
F.2.4.3	UC-609 for Tritium	F-8
F.2.4.4	DOT-6M	F-8
F.2.4.5	5320 for Plutonium Oxide and Americium Oxide	F-12
F.2.4.6	Model 72-B for Remote-Handled Transuranic Waste	F-12
F.2.5	Safe Secure Trailers	F-15
F.2.6	1-Ton Chlorine Containers	F-15
F.2.7	Liquid Propane Cargo Tank	F-15
F.2.8	Explosives	F-16
F.3	RISK MEASURES	F-16
F.3.1	Risk Concepts	F-16
F.3.2	Transportation Risk Key Parameters	F-18
F.3.3	Truck-Related Risk Measures	F-19
F.3.3.1	Truck Emissions	F-19
F.3.3.2	Truck Accident Injuries and Fatalities	F-19
F.3.4	Cargo-Related Risk Measures	F-19
F.3.4.1	Incident-Free Risk Measure (Radioactive Materials Only)	F-20
F.3.4.2	Releases from Accidents	F-20
F.4	TRANSPORTATION RISK METHODOLOGY	F-21
F.4.1	Introduction and Overview	F-21
F.4.2	Accident Rates	F-21
F.4.2.1	State-Specific Truck Accident Rates	F-21
F.4.2.2	Regional Truck Accident Rates	F-21
F.4.2.3	On-Site Truck Accident Rate	F-22
F.4.2.4	Safe Secure Tractor Trailer Accident Rate	F-23
F.4.2.5	Aircraft Accident Rate	F-24
F.4.3	Route, Mileage, and Population Density Determination	F-24
F.4.4	RADTRAN and ADROIT Analyses for Radioactive Materials	F-25
F.4.4.1	Incident-Free Risk Parameters	F-26
F.4.4.2	Accident Severity Categories	F-26
F.4.4.3	Package Release Fractions	F-28
F.4.4.4	Respirable Fractions	F-29
F.4.4.5	Health Risk Conversion Factors	F-30

APPENDIX G	
ACCIDENT ANALYSIS	G-1
G.1 INTRODUCTION	G-1
G.1.1 Characterization of the Risk from Accident	G-1
G.1.2 The Meaning of Risk and Frequency as Used in this SWEIS	G-4
G.1.3 Determining the Increment in Risk Among Alternatives	G-4
G.1.4 The Methodology for Selection of Accidents for Analysis	G-5
G.1.5 Comparison of Other Accident Analysis to the SWEIS	G-7
G.1.5.1 DOE Hazard Assessments	G-7
G.1.5.2 Accident Analysis for this SWEIS	G-8
G.1.6 Conservatism in the Analyses	G-8
G.2 HAZARDOUS MATERIALS IMPACTS ON HUMAN HEALTH	G-9
G.2.1 Sources of Radiation	G-9
G.2.2 Human Health Effects of Exposure to Hazardous Chemicals	G-10
G.2.3 Chemical Accidents—ALOHA™ Code	G-11
G.2.4 Radiological Accidents—MACCS 2 Code	G-12
G.3 ACCIDENT SCENARIO SCREENING	G-14
G.3.1 Accident Initiator Screening	G-15
G.3.2 Facility Hazard Screening	G-16
G.3.2.1 Description of the DOE Hazard Category System	G-23
G.3.2.2 Use of Facility Safety Documentation and Walkdowns	G-30
G.3.2.3 Population Distributions	G-31
G.3.2.4 Dispersion Parameters Used in Screening and Consequence Calculations	G-32
G.3.3 Chemical Accident Screening	G-32
G.3.3.1 Summary of Chemical Accident Screening	G-32
G.3.3.2 Assumptions Inherent in the Screening	G-36
G.3.4 Facility Radiological Accident Screening	G-37
G.3.4.1 Methodology for Consequence Screening	G-37
G.3.4.2 Source Terms	G-37
G.3.4.3 Identification of Accident Scenarios	G-38
G.3.4.4 Addition of Site-Wide Wildfire to Screening Results	G-39
G.3.5 Worker Accident Screening	G-39
G.4 EVALUATION OF RISK-DOMINANT ACCIDENTS	G-44
G.4.1 Accident Frequency Assessment	G-44
G.4.1.1 Earthquake Frequencies	G-44

G.4.1.2	Fire and Other Accident Frequencies and 1969 Rocky Flats Fire	G-50
G.4.1.3	Aircraft Crash Frequencies	G-55
G.4.2	Accident Source Term Assessment	G-69
G.4.2.1	Chemical Accident Source Terms	G-69
G.4.2.2	Radiological Accident Source Terms	G-71
G.5	ACCIDENT CONSEQUENCE ASSESSMENT	G-75
G.5.1	Note on Worker Consequences	G-75
G.5.2	Note on Soil Contamination	G-75
G.5.3	Note on the Consequences from Earthquakes	G-87
G.5.4	Site-Wide Earthquake and Wildfire Accidents	G-87
G.5.4.1	SITE-01, Site-Wide Earthquake Causing Damage to Low-Capacity Structures/Internals	G-88
G.5.4.2	SITE-02, Site-Wide Earthquake Causing Damage to Low- and Moderate-Capacity Structures/Internals	G-98
G.5.4.3	SITE-03, Site-Wide Earthquake Causing Damage to All Structures/Internals	G-99
G.5.4.4	SITE-04, Site-Wide Wildfire Consuming Combustible Structures and Vegetation	G-100
G.5.5	Chemical Accidents	G-125
G.5.5.1	CHEM-01, Single Cylinder Release of Chlorine from Potable Water Chlorinator	G-125
G.5.5.2	CHEM-02, Multiple Cylinder Release of Chlorine from Gas Plant	G-129
G.5.5.3	CHEM-03, Single Cylinder Chlorine Release from Gas Plant	G-136
G.5.5.4	CHEM-04, Single Container Release of Toxic Gas from Waste Gas Cylinder Storage	G-139
G.5.5.5	CHEM-05, Multiple Cylinder Release of Toxic Gas from Waste Gas Cylinder Storage at TA-54-216	G-142
G.5.5.6	CHEM-06, Chlorine Gas Release from Outside the Plutonium Facility	G-146
G.5.6	Radiological Accidents	G-151
G.5.6.1	RAD-01, TRU Waste Container Storage Area Fire at NDA/NDE Facility (TA-54-38)	G-151
G.5.6.2	RAD-02, Natural Gas Pipeline Failure, Ingestion, and Explosion/Fire at CMR	G-154
G.5.6.3	RAD-03, Power Excursion Accident with Fast Burst Assembly Outside Kiva #3	G-160
G.5.6.4	RAD-04, Inadvertent Detonation of Plutonium-Containing Assembly at DARHT	G-167

G.5.6.5	RAD-05, Aircraft Crash and Tritium Release at TSTA/TSFF	G-174
G.5.6.6	RAD-06, Aircraft Crash and Plutonium Release from RAMROD	G-175
G.5.6.7	RAD-07, TRU Waste Container Storage Area Fire at WCRR Facility	G-180
G.5.6.8	RAD-08, Aircraft Crash and Plutonium Release from TA-54 TWISP Storage Domes	G-185
G.5.6.9	RAD-09, Plutonium Release from TRU Waste Drum Failure or Puncture.	G-194
G.5.6.10	RAD-10, Plutonium Release from Degraded Vault Storage Container at TA-55-4	G-205
G.5.6.11	RAD-11, Container Breach After Detonation of Plutonium-Containing Assembly at DARHT	G-209
G.5.6.12	RAD-12, Plutonium Release from a Seismically Initiated Event	G-212
G.5.6.13	RAD-13, Plutonium Release from Flux Trap Irradiation Experiment.	G-214
G.5.6.14	RAD-14, Plutonium Release Due to Ion-Exchange Column Thermal Excursion	G-220
G.5.6.15	RAD-15, Plutonium Release from Laboratory and Wing Fires at CMR	G-232
G.5.6.16	RAD-16, Plutonium Release Due to Aircraft Crash and Fire at CMR	G-245
G.5.7	Facility Hazard Accidents	G-251
G.5.7.1	WORK-01, Inadvertent High Explosives Detonation.	G-251
G.5.7.2	WORK-02, Biohazard Contamination of a Single Worker	G-256
G.5.7.3	WORK-03, Inadvertent Nuclear Criticality Event	G-258
G.5.7.4	WORK-04, Inadvertent Worker Exposure to Electromagnetic Radiation.	G-262
G.5.7.5	Work-05, Plutonium Release from Degraded Vault Storage Container at TA-55-4	G-263
G.6	UNCERTAINTIES AND SENSITIVITIES	G-267
	REFERENCES	G-268

APPENDIX H
SUPPLEMENTAL ANALYSIS FOR THE ENHANCEMENT OF PIT
MANUFACTURING AT LOS ALAMOS NATIONAL LABORATORY,
STOCKPILE STEWARDSHIP AND MANAGEMENT PROGRAMMATIC
ENVIRONMENTAL IMPACT STATEMENT..... H-1

APPENDIX I
REPORT ON THE STATUS AND IMPLICATIONS OF
SEISMIC HAZARD STUDIES AT LANL I-1

**OTHER PARTS OF THIS SWEIS
(BOUND SEPARATELY FROM THIS VOLUME):**

SUMMARY

**VOLUME I
MAIN REPORT**

**VOLUME II
PROJECT-SPECIFIC SITING AND CONSTRUCTION ANALYSES**

**VOLUME IV
COMMENT RESPONSE DOCUMENT**

VOLUME III

LIST OF FIGURES

FIGURE A.3-1	Diagrammatic Section of Model Layers and Subsurface Geology.	A-7
FIGURE A.3-2	Area USGS Modeled.	A-8
FIGURE B.1.2.4-1	Annual Average Individual Doses Higher Than 1 Millirem per Year for the No Action Alternative.	B-30
FIGURE B.1.2.4-2	Annual Average Individual Doses Higher Than 1 Millirem per Year for the Expanded Operations Alternative.	B-31
FIGURE B.1.2.4-3	Annual Average Individual Doses Higher Than 1 Millirem per Year for the Reduced Operations Alternative.	B-32
FIGURE B.1.2.4-4	Annual Average Individual Doses Higher Than 1 Millirem per Year for the Greener Alternative.	B-33
FIGURE B.1.2.4-5	Annual Average Individual Doses Less Than 1 Millirem per Year for the No Action Alternative.	B-34
FIGURE B.1.2.4-6	Annual Average Individual Doses Less Than 1 Millirem per Year for the Expanded Operations Alternative.	B-35
FIGURE B.1.2.4-7	Annual Average Individual Doses Less Than 1 Millirem per Year for the Reduced Operations Alternative.	B-36
FIGURE B.1.2.4-8	Annual Average Individual Doses Less Than 1 Millirem per Year for the Greener Alternative.	B-37
FIGURE B.2.3-1	Process Used for Evaluating Toxic Air Pollutants.	B-43
FIGURE B.2.3-2	Procedures for Evaluating Potential Impacts of Toxic Air Pollutant Emissions from Each Technical Area.	B-44
FIGURE D.1.2.4-1	5-Year Average Annual Incidence of All Cancer Sites, Los Alamos County, New Mexico NHW, SEER Whites, 1970 to 1990.	D-19
FIGURE D.1.2.4-2	5-Year Average Annual Incidence of Liver and Intra-Hepatic Bile Duct Cancer, Los Alamos County, New Mexico NHW, SEER Whites, 1970 to 1990.	D-19

FIGURE D.1.2.4-3	5-Year Average Annual Incidence of Non-Hodgkin's Lymphoma, Los Alamos County, New Mexico NHW, SEER Whites, 1970 to 1990.....	D-20
FIGURE D.1.2.4-4	5-Year Average Annual Incidence of Leukemia, Los Alamos County, New Mexico NHW, SEER Whites, 1970 to 1990.....	D-20
FIGURE D.1.2.4-5	5-Year Average Annual Incidence of Melanoma of Skin, Los Alamos County, New Mexico NHW, SEER Whites, 1970 to 1990.....	D-21
FIGURE D.1.2.4-6	5-Year Average Annual Incidence of Ovarian Cancer, Los Alamos County, New Mexico NHW, SEER Whites, 1970 to 1990.	D-22
FIGURE D.1.2.4-7	5-Year Average Annual Incidence of Female Breast Cancer, Los Alamos County, New Mexico NHW, SEER Whites, 1970 to 1990.....	D-22
FIGURE D.1.2.4-8	Average Annual Incidence of Childhood Cancer (0 to 19 Years), Los Alamos County, New Mexico NHW, SEER Whites, 1970 to 1990.....	D-23
FIGURE D.1.2.4-10	5-Year Average Annual Incidence of Brain and Nervous System Cancer, Los Alamos County, New Mexico NHW, SEER Whites, 1970 to 1990.	D-24
FIGURE D.1.2.4-9	5-Year Average Annual Incidence of Thyroid Cancer, Los Alamos County, New Mexico NHW, SEER Whites, 1970 to 1990.	D-24
FIGURE F.2-1	Examples of Packaging Types.....	F-4
FIGURE F.2.3-1	Type A DOT-17H 55-Gallon (208-Liter) Steel Drum.	F-6
FIGURE F.2.4.1-1	Cross Section of an FL-Type Container.	F-7
FIGURE F.2.4.2-1	TRUPACT-II.....	F-9
FIGURE F.2.4.3-1	Model No. UC-609 Shipping Package.	F-10
FIGURE F.2.4.4-1	55-Gallon (208-Liter) 6M Packaging.	F-11
FIGURE F.2.4.5-1	5320 Plutonium Oxide and Americium Oxide Shipping Cask.	F-13
FIGURE F.2.4.6-1	Cross Section of Model 72-B Cask.....	F-14

FIGURE F.3-1	Transportation Risk Analysis Methodology.	F-17
FIGURE F.4.5-1	Event Tree Analysis of Puncture Accidents.	F-32
FIGURE G.1.1-1	Facility Accident Risk Matrix.	G-3
FIGURE G.4.1.2-1	Rocky Flats Site, Glovebox 123-24	G-52
FIGURE G.5.4.4-1	Location of the Los Alamos National Laboratory.	G-102
FIGURE G.5.6.4-1	DARHT EIS Most Populated Sector and the Distribution of Minority Populations.	G-173

VOLUME I

LIST OF TABLES

TABLE A.1-1	Volume of NPDES by Watershed for Index and Alternativesa	A-2
TABLE A.2-1	Hydraulic Characteristics of Groundwater Bodies, LANL Region	A-6
TABLE A.3-1	Estimated Water Storage of Main Aquifer Beneath Pajarito Plateau.	A-9
TABLE A.3-2	Estimated Water Storage of Main Aquifer Within the Area USGS Modeled.	A-10
TABLE A.3-3	Water Rights for Española Basin	A-11
TABLE A.4.1-1	Annual Water Use Projections	A-12
TABLE A.4.1-2	Estimated Annual Water Use for Santa Fe County	A-13
TABLE A.5.1-1	Maximum Water Level Changes at the Top of the Main Aquifer Due to All Users Combined (1996 Through 2006)	A-15
TABLE B.1.1-1	Historical Summary of Dose Estimates to LANL's Maximally Exposed Individual from Radioactive Air Emissions (1990 Through 1994)	B-2
TABLE B.1.1.1-1	List of Facilities Modeled for Radionuclide Air Emissions from LANL. . .	B-4
TABLE B.1.1.4-1	Radiological Air Emissions from TA-3-29 (CMR).	B-6
TABLE B.1.1.4-2	Radiological Air Emissions from TA-3-66 (Sigma)	B-7
TABLE B.1.1.4-3	Radiological Air Emissions from TA-11 (High Explosives Testing)	B-8
TABLE B.1.1.4-4	Radiological Air Emissions from TA-16 (Tritium Facility)	B-8
TABLE B.1.1.4-5	Radiological Air Emissions from TA-18 (Pajarito Site)	B-8
TABLE B.1.1.4-6	Radiological Air Emissions from TA-21 (Tritium Facility)	B-9
TABLE B.1.1.4-7	Radiological Air Emissions from TA-3-102 (Shops)	B-9
TABLE B.1.1.4-8	Radiological Air Emissions from TA-48 (Radiochemistry Laboratory) . .	B-10
TABLE B.1.1.4-9	Radiological Air Emissions from TA-48 (Radiochemistry Laboratory) . .	B-11
TABLE B.1.1.4-10	Radiological Air Emissions from TA-55 (Plutonium Facility)	B-11

TABLE B.1.1.4-11	Radiological Air Emissions from TA-15 and TA-36 (Firing Sites)	B-12
TABLE B.1.1.4-12	Radiological Air Emissions from TA-54 (Area G—Waste Management)	B-13
TABLE B.1.1.4-13	Radiological Air Emissions from TA-53 (LANSCE—ES-2 Stack)	B-13
TABLE B.1.1.4-14	Radiological Air Emissions from TA-53 (LANSCE—ES-3 Stack)	B-14
TABLE B.1.1.4-15	Radiological Air Emissions from TA-53 (LANSCE—LEDA)	B-14
TABLE B.1.1.4-16	Radiological Air Emissions from TA-53 (LANSCE—IPF-2)	B-15
TABLE B.1.1.4-17	Radiological Air Emissions from TA-53 (LANSCE—Diffuse)	B-15
TABLE B.1.1.4-18	Fraction of Agricultural Products Produced in the Home, Assessment Area, and Imported	B-16
TABLE B.1.1.4-19	Distances (Meters) and Directions Between the Modeled Facilities and the Facility-Specific MEI	B-18
TABLE B.1.1.5-1	Distance and Directions to Facility-Specific Maximally Exposed Individuals	B-20
TABLE B.1.2.1-1	Doses to Facility-Specific MEIs from LANL Operations for the No Action Alternative (millirems per year)	B-22
TABLE B.1.2.1-2	Doses to Facility-Specific MEIs from LANL Operations for the Expanded Operations Alternative (millirems per year)	B-23
TABLE B.1.2.1-3	Doses to Facility-Specific MEIs from LANL Operations for the Reduced Operations Alternative (millirems per year)	B-24
TABLE B.1.2.1-4	Doses to Facility-Specific MEIs from LANL Operations for the Greener Alternative (millirems per year)	B-25
TABLE B.1.2.1-5	Total Doses to the Facility-Specific Maximally Exposed Individuals from LANL Operations (millirems per year)	B-26
TABLE B.1.2.2-1	Doses to the LANL Site-Wide Maximally Exposed Individual for Each of the SWEIS Alternatives.	B-26
TABLE B.1.2.3-1	Collective Population Dose to Residents Within a 50-mile Radius from LANL (person-rem/year)	B-27
TABLE B.1.2.3-2	Total Collective Population Doses for Each of the SWEIS Alternatives.	B-28

TABLE A	Peak Load Emission Rates Used for the Combustion Sources Analysis (Boilers, Incinerator, and Natural Gas Fired Emergency Generators) . . .	B-55
TABLE B	Peak Load Emission Rates Used for the Combustion Sources Analysis (Diesel and Gasoline Fired Emergency Generators)	B-58
TABLE C	Annual Average Emission Rates Used for the Combustion Source Analysis	B-61
	Toxic Chemicals Considered for the Analysis	B-64
	Set of Sensitive Receptors for Nonradiological Air Quality Analysis . . .	B-72
TABLE A	The ISC-3 Estimated 8-Hour and Annual Concentrations Associated with LANL Technical Areas Using 1991-1995 Meteorological Data . . .	B-77
TABLE 1 (PART A)	8-Hour SLEVs of the Toxic (Noncarcinogenic and Carcinogenic) Air Pollutants from TA-3 Facilities Based on RAPS-90 (LANL 1990) and ACIS 1995 (LANL 1995a) Data	B-80
TABLE 1 (PART B)	8-Hour SLEVs of the Potentially Sensitive Toxic Air Pollutants (Noncarcinogenic and Carcinogenic) from TA-3 Facilities Based on RAPS-90 (LANL 1990) and ACIS 1995 (LANL 1995a) Data	B-99
TABLE 1 (PART C)	8-Hour SLEVs of Potentially Sensitive Noncarcinogenic Pollutants from Building 1 of TA-3	B-102
TABLE 1 (PART D)	8-Hour SLEVs of Potentially Sensitive Noncarcinogenic and Carcinogenic Pollutants from Building 16 of TA-3.	B-102
TABLE 1 (PART E)	8-Hour SLEVs of Potentially Sensitive Noncarcinogenic and Carcinogenic Pollutants from Building 29 of TA-3	B-103
TABLE 1 (PART F)	8-Hour SLEVs of Potentially Sensitive Noncarcinogenic Pollutants from Building 22 of TA-3	B-104
TABLE 1 (PART G)	8-Hour SLEVs of Potentially Sensitive Noncarcinogenic Pollutants from Building 30 of TA-3	B-105
TABLE 1 (PART H)	8-Hour SLEVs of Potentially Sensitive Noncarcinogenic Pollutants from Building 25 of TA-3	B-105
TABLE 1 (PART I)	8-Hour SLEVs of Potentially Sensitive Noncarcinogenic Pollutants from TABLE Building 32 of TA-3	B-106
TABLE 1 (PART J)	8-Hour SLEVs of Potentially Sensitive Noncarcinogenic and Carcinogenic Pollutants from Building 34 of TA-3.	B-107

TABLE 1 (PART K)	8-Hour SLEVs of Potentially Sensitive Noncarcinogenic Pollutants from Building 35 of TA-3	B-108
TABLE 1 (PART L)	8-Hour SLEVs of Potentially Sensitive Noncarcinogenic Pollutants from Building 35 of TA-3	B-108
TABLE 1 (PART M)	8-Hour SLEVs of Potentially Sensitive Noncarcinogenic and Carcinogenic Pollutants from Building 39 of TA-3.	B-109
TABLE 1 (PART N)	8-Hour SLEVs of Potentially Sensitive Noncarcinogenic and Carcinogenic Pollutants from Building 40 of TA-3.	B-110
TABLE 1 (PART O)	8-Hour SLEVs of Potentially Sensitive Noncarcinogenic Pollutants from Building 43 of TA-3	B-111
TABLE 1 (PART P)	8-Hour SLEVs of Potentially Sensitive Noncarcinogenic and Carcinogenic Pollutants from Building 66 of TA-3	B-112
TABLE 1 (PART Q)	8-Hour SLEVs of Potentially Sensitive Noncarcinogenic Pollutants from Building 70 of TA-3	B-114
TABLE 1 (PART R)	8-Hour SLEVs of Potentially Sensitive Noncarcinogenic Pollutants from Building 142 of TA-3	B-114
TABLE 1 (PART S)	8-Hour SLEVs of Potentially Sensitive Noncarcinogenic Pollutants from Building 102 of TA-3	B-115
TABLE 1 (PART T)	8-Hour SLEVs of Potentially Sensitive Noncarcinogenic Pollutants from Building 102 of TA-3	B-115
TABLE 1 (PART U)	8-Hour SLEVs of Potentially Sensitive Noncarcinogenic Pollutants from Building 132 of TA-3	B-116
TABLE 1 (PART V)	8-Hour SLEVs of Potentially Sensitive Noncarcinogenic and Carcinogenic Pollutants from Building 141 of TA-3.	B-116
TABLE 1 (PART W)	8-Hour SLEVs of Potentially Sensitive Noncarcinogenic Pollutants from Building 170 of TA-3	B-117
TABLE 1 (PART X)	8-Hour SLEVs of Potentially Sensitive Noncarcinogenic and Carcinogenic Pollutants from Building 223 of TA-3.	B-117
TABLE 1 (PART Y)	8-Hour SLEVs of Potentially Sensitive Noncarcinogenic Pollutants from Building 287 of TA-3	B-118
TABLE 1 (PART Z)	8-Hour SLEVs of Potentially Sensitive Noncarcinogenic Pollutants from Building 316 of TA-3	B-118

TABLE 1 (PART AA)	8-Hour SLEVs of Potentially Sensitive Noncarcinogenic Pollutants from Building 409 of TA-3	B-119
TABLE 1 (PART BB)	8-Hour SLEVs of Potentially Sensitive Noncarcinogenic Pollutants from Building 425 of TA-3	B-119
TABLE 1 (PART CC)	8-Hour SLEVs of Potentially Sensitive Noncarcinogenic Pollutants from Building 494 of TA-3	B-120
TABLE 1 (PART DD)	8-Hour SLEVs of Potentially Sensitive Noncarcinogenic Pollutants from Building 495 of TA-3	B-121
TABLE 1 (PART EE)	8-Hour SLEVs of Potentially Sensitive Noncarcinogenic Pollutants from Building 502 of TA-3	B-121
TABLE 1 (PART FF)	8-Hour SLEVs of Potentially Sensitive Noncarcinogenic Pollutants from Building 562 of TA-3	B-122
TABLE 1 (PART GG)	8-Hour SLEVs of Potentially Sensitive Noncarcinogenic Pollutants from Building 43/510 of TA-3	B-122
TABLE 1 (PART HH)	8-Hour SLEVs of Potentially Sensitive Noncarcinogenic Pollutants from Building 1498 of TA-3	B-123
TABLE 1 (PART II)	8-Hour SLEVs of Potentially Sensitive Noncarcinogenic Pollutants from Building 1559 of TA-3	B-123
TABLE 1 (PART JJ)	8-Hour SLEVs of Potentially Sensitive Noncarcinogenic Pollutants from Building 1698 of TA-3	B-124
TABLE 1 (PART KK)	8-Hour SLEVs of Potentially Sensitive Noncarcinogenic Pollutants from Building 1701 of TA-3	B-124
TABLE 1 (PART LL)	8-Hour SLEVs of Potentially Sensitive Noncarcinogenic Pollutants from Building 2202 of TA-3	B-125
TABLE 1 (PART MM)	8-Hour SLEVs of Potentially Sensitive Noncarcinogenic Pollutants from Building 2203 of TA-3	B-125
TABLE 1 (PART NN)	8-Hour SLEVs of Potentially Sensitive Noncarcinogenic Pollutants from Building 2010 of TA-3	B-126
TABLE 2 (PART A)	Annual SLEVs of the Carcinogenic Pollutants from TA-3 Facilities	B-127
TABLE 2 (PART B)	Annual SLEVs of Potentially Sensitive Carcinogenic Pollutants from TA-3	B-130

TABLE 2 (PART C)	Annual SLEVs of Potentially Sensitive Carcinogenic Pollutants from Building 16 of TA-3.	B-131
TABLE 2 (PART D)	Annual SLEVs of Potentially Sensitive Carcinogenic Pollutants from Building 29 of TA-3.	B-131
TABLE 2 (PART E)	Annual SLEVs of Potentially Sensitive Carcinogenic Pollutants from Building 30 of TA-3.	B-132
TABLE 2 (PART F)	Annual SLEVs of Potentially Sensitive Carcinogenic Pollutants from Building 34 of TA-3.	B-132
TABLE 2 (PART G)	Annual SLEVs of Potentially Sensitive Carcinogenic Pollutants from Building 37 of TA-3.	B-133
TABLE 2 (PART H)	Annual SLEVs of Potentially Sensitive Carcinogenic Pollutants from Building 38 of TA-3.	B-133
TABLE 2 (PART I)	Annual SLEVs of Potentially Sensitive Carcinogenic Pollutants from Building 39 of TA-3.	B-134
TABLE 2 (PART J)	Annual SLEVs of Potentially Sensitive Carcinogenic Pollutants from Building 40 of TA-3.	B-134
TABLE 2 (PART K)	Annual SLEVs of Potentially Sensitive Carcinogenic Pollutants from Building 43 of TA-3.	B-135
TABLE 2 (PART L)	Annual SLEVs of Potentially Sensitive Carcinogenic Pollutants from Building 43 510 of TA-3	B-135
TABLE 2 (PART M)	Annual SLEVs of Potentially Sensitive Carcinogenic Pollutants from Building 65 of TA-3.	B-136
TABLE 2 (PART N)	Annual SLEVs of Potentially Sensitive Carcinogenic Pollutants from Building 66 of TA-3.	B-136
TABLE 2 (PART O)	Annual SLEVs of Potentially Sensitive Carcinogenic Pollutants from Building 70 of TA-3.	B-137
TABLE 2 (PART P)	Annual SLEVs of Potentially Sensitive Carcinogenic Pollutants from Building 73 of TA-3.	B-137
TABLE 2 (PART Q)	Annual SLEVs of Potentially Sensitive Carcinogenic Pollutants from Building 102 of TA-3.	B-138
TABLE 2 (PART R)	Annual SLEVs of Potentially Sensitive Carcinogenic Pollutants from Building 105 of TA-3.	B-138

TABLE 2 (PART S)	Annual SLEVs of Potentially Sensitive Carcinogenic Pollutants from Building 103 of TA-3.	B-139
TABLE 2 (PART T)	Annual SLEVs of Potentially Sensitive Carcinogenic Pollutants from Building 218 of TA-3.	B-139
TABLE 2 (PART U)	Annual SLEVs of Potentially Sensitive Carcinogenic Pollutants from Building 287 of TA-3.	B-140
TABLE 2 (PART V)	Annual SLEVs of Potentially Sensitive Carcinogenic Pollutants from Building 1698 of TA-3.	B-140
TABLE 2 (PART W)	Annual SLEVs of Potentially Sensitive Carcinogenic Pollutants from Building 495 of TA-3.	B-141
TABLE 2 (PART X)	Annual SLEVs of Potentially Sensitive Carcinogenic Pollutants from Building 1819 of TA-3.	B-141
TABLE A (PART 1)	Emission Rates of the Carcinogenic Pollutants Considered in the Additive Impact Analysis	B-147
TABLE A (PART 2)	Emission Rates of the Carcinogenic Pollutants Considered in the Additive Impact Analysis	B-149
TABLE A (PART 3)	Emission Rates of the Carcinogenic Pollutants Considered in the Additive Impact Analysis	B-150
TABLE A (PART 4)	Emission Rates of the Carcinogenic Pollutants Considered in the Additive Impact Analysis	B-152
TABLE A (PART 5)	Emission Rates of the Carcinogenic Pollutants Considered in the Additive Impact Analysis	B-153
TABLE A (PART 6)	Emission Rates of the Carcinogenic Pollutants Considered in the Additive Impact Analysis	B-155
TABLE B	Results of the Additive Impact Analysis of the Cancer Risk Associated with Releases of Each Carcinogenic Pollutant from All TAs Combined	B-157
TABLE C	Total Combined Cancer Risks of All Carcinogenic Pollutants from All TAs (Regardless of the Receptor Locations Where Maximum Values Are Estimated)	B-159
TABLE D (PART 1)	Total Combined Cancer Risk of All Pollutants from All TAs	B-161
TABLE D (PART 2)	Total Combined Cancer Risk of All Pollutants from All TAs	B-168

TABLE D (PART 3)	Total Combined Cancer Risk of All Pollutants from All TAs	B-175
TABLE A	Stack Parameters and Emission Rate of the Methylene Chloride Associated with the TA-3 CMR Facility (Building 29).	B-184
TABLE B	ISC-3 Estimated Annual Concentration of the Methylene Chloride Associated with Emission Source of the TA-3 CMR Facility Using 1991-1995 Meteorological Data	B-184
TABLE C	Results of the Dispersion Modeling Analysis of the Methylene Chloride Emissions from the CMR Facility of the TA-3.	B-184
TABLE A	Stack Parameters and Beryllium Annual Emission Rate Associated with Buildings 102 and SM141 of the TA-3 Facility	B-187
TABLE B	TA-3 ISC-3 Estimated Annual Average Concentration of the Beryllium Using 1991 to 1995 Meteorological Data	B-187
TABLE C	Results of the Dispersion Modeling Analysis of the Beryllium Emissions from TA-3.	B-187
TABLE A	Stack Parameters and Emission Rate of the Nickel Dust Associated with TA-3 Shops Complex (Building 102)	B-190
TABLE B	ISC-3 Estimated Annual Concentration of the Nickel Dust Associated with Emission Source of the TA-3 Shops Complex Using Meteorological Data (1991 to 1995)	B-190
TABLE C	Results of the Dispersion Modeling Analysis of the Nickel Dust Emissions from Shops Complex (Building 102) of TA-3	B-190
TABLE A	8-Hour SLEV/Q Ratios of the Toxic (Noncarcinogenic and Carcinogenic) Air Pollutants from TA-3-38 Paint Booth1	B-193
TABLE B	Annual SLEV/Q Ratios of the Carcinogenic Pollutants from TA-3-38 Paint Booth	B-195
TABLE C	8-Hour SLEV/Q Ratios of the Toxic (Noncarcinogenic and Carcinogenic) Air Pollutants from TA-3-38 Paint Booth1	B-196
TABLE D	Annual SLEV/Q Ratios of the Carcinogenic Pollutants from TA-3-38 Paint Booth	B-198
TABLE E	8-Hour SLEV/Q Ratios of the Toxic (Noncarcinogenic and Carcinogenic) Air Pollutants from TA-60-17 Paint Booth1	B-199

TABLE F	Annual SLEV/Q Ratios of the Carcinogenic Pollutants from TA-60-17 Paint Booth	B-201
TABLE A	Annual SLEV/Q Ratios for the Toxic Carcinogenic Air Pollutants from TA-16 Incinerator Burning HE-Contaminated Paper Waste	B-206
TABLE B	Annual Emission Rates for the Criteria Pollutants from TA-16 Incinerator Burning HE-Contaminated Paper Waste	B-207
TABLE C	Annual Impact Analysis of the Criteria Pollutants from TA-16 Incinerator Burning HE-Contaminated Paper Waste	B-208
TABLE D	8-Hour SLEV/Q Ratios for the Toxic and Criteria Air Pollutants from TA-16 Incinerator Burning HE-Contaminated Oil	B-209
TABLE E	Annual SLEV/Q for the Toxic Carcinogenic Air Pollutants from TA-16 Incinerator Burning HE-Contaminated Oil	B-211
TABLE F	Annual Emission Rates of the Criteria Pollutants from TA-16 Incinerator Burning HE-Contaminated Oil.	B-212
TABLE G	Annual Impact Analysis of the Criteria Pollutants from TA-16 Incinerator Burning HE-Contaminated Oil.	B-213
TABLE A	Emissions of HE-Contaminated Solvents from Open Burn at TA-16 . . .	B-218
TABLE B	Emissions of HE-Contaminated Oil from Open Burning at TA-16.	B-219
TABLE C	8-Hour SLEV/Q Ratios of the Toxic Air Pollutants from Open Burning of HE-Contaminated Solvents at TA-16	B-220
TABLE D	8-Hour SLEV/Q Ratios of the Toxic Air Pollutants from Open Burning of HE-Contaminated Oil at TA-16.	B-221
TABLE E	8-Hour SLEV/Q Ratios of the Criteria Pollutants from Open Burning of HE-Contaminated Solvents at TA-16	B-222
TABLE F	8-Hour SLEV/Q Ratios of the Criteria Pollutants from Open Burning of HE-Contaminated Oil at TA-16.	B-223
TABLE G	VOC/HAP Emissions from Open Burning of Scrap HE at TA-16	B-224
TABLE H	8-Hour SLEV/Q Ratios of the Toxic Air Pollutants from Open Burning of Scrap HE at TA-16	B-225
TABLE I	Annual SLEV/Q Ratios of the Toxic Air Pollutants from Open Burning of Scrap HE at TA-16	B-226

TABLE J	Annual SLEV/Q Ratios of the Toxic Air Pollutants from Open Burning of Scrap HE at TA-16	B-227
TABLE K	Annual Impact Analysis of the Criteria Pollutants from Open Burning of Scrap HE at TA-16-388	B-228
TABLE A	Estimated Emission Rates of the Pollutants That Have the Potential to be Released from High Explosives Firing Sites (HEFSs)	B-235
TABLE B	Air Quality Impact Analysis of the Pollutants That Have the Potential to be Released from High Explosives Firing Sites (HEFSs)	B-237
TABLE A	Stack Parameters and Estimated Annual Emission Rates of the Carcinogenic Pollutants That Have the Potential to be Released from the Health Research Laboratory of the TA-43 Facilities	B-241
TABLE B	ISC-3 Estimated Annual Concentrations of the Carcinogenic Pollutants That Have the Potential to be Released from the Health Research Laboratory of the TA-43 Facilities Using 1991 to 1995 Meteorological Data	B-242
TABLE C	Results of the Dispersion Modeling Analysis of the Carcinogenic Pollutants from the Health Research Laboratory at TA-43	B-242
TABLE A	Stack Parameters and Emission Rate of the Chloroform Associated with TA-53 Building MPF-15	B-244
TABLE B	ISC-3-Estimated Annual Concentration of the Chloroform Associated with Emission Source of the TA-53 MPF-15 Using 1991 to 1995 Meteorological Data	B-244
TABLE C	Results of the Dispersion Modeling Analysis of the Chloroform Emissions from TA-53 Building MPF-15	B-244
TABLE A	Stack Parameters and Annual Beryllium Emission Rates Associated with TA-55 Building PF-4 Emission Sources FE-15 and FE-16	B-246
TABLE B	TA-55 ISC-3 Estimated Annual Concentrations of the Beryllium Using 1991 to 1995 Meteorological Data	B-246
TABLE C	Results of the Dispersion Modeling Analysis of the Beryllium Emissions from TA-55 Sources FE-15 and FE-16	B-246
TABLE A	Stack Parameters and Emission Rate of Hydrochloric and Nitric Acid Associated with TA-55 Building PF-4	B-248

TABLE B	ISC-3 Estimated 8-Hour Concentration of the Hydrochloric and Nitric Acid Associated with TA-55 Building PF-4 Using 1991 to 1995 Meteorological Data	B-248
TABLE C	Results of the Dispersion Modeling Analysis of the Hydrochloric and Nitric Acid Emission from TA-55 Building PF-4 Stack FE-15 and FE-16.	B-249
TABLE A	Stack Parameters and Emission Rate of the Hydrochloric and Nitric Acid Associated with Emission Sources of the TA-59 Building 1	B-252
TABLE B	ISC-3 Estimated 8-Hour Concentration of the Hydrochloric and Nitric Acid Associated with Emission Source of the TA-59 Building 1 Using 1991 to 1995 Meteorological Data.	B-253
TABLE C	Results of the Dispersion Modeling Analysis of the Hydrochloric and Nitric Acid Emissions from TA-59 Building 1	B-253
TABLE A	Stack Parameters and Emission Rate Associated with Ozone Emissions from TA-53 Building MPF-14.	B-256
TABLE B	ISC-3 Estimated 1-Hour Concentration of the Ozone Associated with Emission Source of the TA-53 MPF-14 Using 1991 to 1995 Meteorological Data	B-256
TABLE C	ISC-3 Estimated 8-Hour Ozone Concentration Associated with Emission Source of the TA-53 MPF-14 Using 1991 to 1995 Meteorological Data	B-257
TABLE D	Results of the Dispersion Modeling Analysis of the Ozone Emissions from TA-53 Building MPF-14.	B-257
TABLE C-1	NPDES Detection Statistics by Watershed (NPDES Data 1994 to 1996)	C-3
TABLE C-2	Surface Water Detection Statistics by Location and Analyte (Environmental Surveillance Report Data 1991 to 1996)	C-8
TABLE C-3	Surface Water Detection Statistics by Watershed and Analyte (Environmental Surveillance Report Data 1991 to 1996)	C-16
TABLE C-4	Sediment Detection Statistics by Location and Analyte (Environmental Surveillance Report Data 1991 to 1996)	C-39
TABLE C-5	Sediment Detection Statistics by Watershed and Analyte (Environmental Surveillance Report Data 1991 to 1996)	C-44

TABLE C-6	Groundwater Detection Statistics by Regime and Analyte (Environmental Surveillance Report Data 1991 to 1996)	C-63
TABLE C-7	Groundwater Detection Statistics by Watershed and by Analyte (Environmental Surveillance Report Data 1991 to 1996)	C-85
TABLE C-8	Soil Detection Statistics by Watershed and by Analyte (ER Risk Database [LANL 1998]—Organics)	C-104
TABLE C-9	Soil Detection Statistics by Watershed and by Analyte (ER Risk Database [LANL 1998]—Inorganics and Radiochemistry)	C-131
TABLE D.1.1-1	Comparison of Consequences of Radioactivity and Toxic Chemicals	D-2
TABLE D.1.1.2-1	Risk Factors for Cancer Induction and Heritable Genetic Effects from Exposure to Ionizing Radiation	D-5
TABLE D.1.2.1-1	Leading Causes of Death in U.S.: Percent of All Causes of Death (1973 Versus 1993).	D-12
TABLE D.1.2.1-2	Lifetime Risk (Expressed as Percent) of Dying from Cancer: SEER Areas (1973 Through 1993), All Races.	D-13
TABLE D.1.2.1-3	Trends in Cancer Incidence and Mortality for Selected Cancers (1973 Through 1993), All Races, Both Sexes	D-14
TABLE D.1.2.2-1	Comparison of Cancer Mortality Rates for the United States and New Mexico (1989 Through 1993), All Races, Both Sexes (Rate per 100,000 Population, Age Adjusted to 1970 U.S. Standard Population)	D-15
TABLE D.1.2.3-1	The Five Most Frequently Diagnosed Cancer and the Five Most Common Types of Cancer Death (1988 Through 1992) Among White Non-Hispanics (all U.S.), White Hispanics (all U.S.), Native Americans (New Mexico)	D-17
TABLE D.1.2.4-1	Average Annual Age-Adjusted Mortality Rates by Cancer Type for Los Alamos County and U.S. Whites (1969 to 1987)	D-26
TABLE D.1.2.4-2	Average Annual Age-Adjusted Cancer Incidence Rates for Sub-County Regions of Los Alamos County, All Races (1980 to 1990). .	D-27
TABLE D.2.1.2-1	Ingestion and Hypothetical Receptors Used to Evaluate Radiological Dose and Potential Public Health Consequence.	D-30
TABLE D.2.1.2-2	Consumption Rates Used for Public Health Consequence Analysis	D-32

TABLE D.2.2.1-1	Groups Used in the Projection of the Worker Doses	D-34
TABLE D.2.2.1-2	Worker Dose for Baseline and Alternatives	D-35
TABLE D.2.2.2-1	Temperature Rise Due to Microwave Exposure (1-Second Exposure Duration).	D-37
TABLE D.2.2.4-1	Projected Recordable Cases per Alternative at LANL	D-39
TABLE D.3.1.1-1	Facility-Specific and LANL-Wide MEI Doses and 50-Mile (80-Kilometer) Population Doses from LANL Continued Operations	D-41
TABLE D.3.2-1	Analysis of Public Health Consequences from Specific Chemicals Emitted from the High Explosives Test Areas (TA-14, TA-15, TA-36, and TA-39) in the No Action, Reduced Operations, and Greener Alternatives	D-43
TABLE D.3.2-2	Analysis of Public Health Consequences from Specific Chemicals Emitted from the High Explosives Test Areas (TA-14, TA-15, TA-36, and TA-39) in the Expanded Operations Alternative (Values Rounded to 2 Significant Digits).	D-44
TABLE D.3.3.2-1	Total Effective Dose Equivalenta for Mortandad Canyon (mrem)	D-47
TABLE D.3.3-1	Ingestion of Radioactive Isotopes from LANL Supply Wells for an Off-Site Los Alamos County Resident	D-50
TABLE D.3.3-2	Ingestion of Metals in LANL Supply Wells to Off-Site Los Alamos County Residents	D-51
TABLE D.3.3-3	Ingestion of Radioactive Isotopes from Supply Well LA-5 for an Off-Site Totavi Resident	D-54
TABLE D.3.3-4	Ingestion of Metals in Supply Well LA-5 for an Off-Site Totavi Resident	D-55
TABLE D.3.3-5	Ingestion of Radioactive Isotopes from San Ildefonso Supply Wells for an Off-Site Non-Los Alamos County Resident	D-58
TABLE D.3.3-6	Ingestion of Metals in San Ildefonso Supply Wells for an Off-Site Non-Los Alamos County Resident	D-59
TABLE D.3.3-7	Ingestion of Radioactive Isotopes in Surface Water for a Resident Recreational User	D-61
TABLE D.3.3-8	Ingestion of Metals in Surface Water to Resident Recreational User	D-62

TABLE D.3.3-9	Ingestion of Radioactive Isotopes in Surface Water for a Nonresident Recreational User	D-65
TABLE D.3.3-10	Ingestion of Metals in Surface Water for a Nonresident Recreational User	D-66
TABLE D.3.3-11	Ingestion of Radioactive Isotopes in NPDES Discharge Water for a Resident Recreational User	D-69
TABLE D.3.3-12	Ingestion of Metals in NPDES Discharge for a Resident Recreational User	D-70
TABLE D.3.3-13	Ingestion of Radioactive Isotopes in NPDES Discharge Water for a Nonresident Recreational User	D-72
TABLE D.3.3-14	Ingestion of Metals in NPDES Discharge for a Nonresident Recreational User	D-73
TABLE D.3.3-15	Ingestion of Radioactive Isotopes in Perimeter Soil for an Off-Site Resident (Nonspecific County).	D-75
TABLE D.3.3-16	Ingestion of Metals in Perimeter Soil to an Off-Site Resident	D-77
TABLE D.3.3-17	Ingestion of Radioactive Isotopes in Soil for a Resident Recreational User	D-79
TABLE D.3.3-18	Ingestion of Metals in Soil for a Resident Recreational User	D-81
TABLE D.3.3-19	Ingestion of Radioactive Isotopes in Soil for a Nonresident Recreational User	D-83
TABLE D.3.3-20	Ingestion of Metals in Soils to a Nonresident Recreational User	D-85
TABLE D.3.3-21	Ingestion of Radioactive Isotopes in Perimeter Sediment for an Off-Site Resident	D-87
TABLE D.3.3-22	Ingestion of Metals in Perimeter Sediments to an Off-Site Resident	D-89
TABLE D.3.3-23	Ingestion of Radioactive Isotopes in Sediment for a Resident Recreational User	D-91
TABLE D.3.3-24	Ingestion of Metals in Sediment for a Resident Recreational User	D-93
TABLE D.3.3-25	Ingestion of Radioactive Isotopes in Sediment for a Nonresident Recreational User	D-96
TABLE D.3.3-26	Ingestion of Metals in Sediment for a Nonresident Recreational User	D-98

TABLE D.3.3–27	Ingestion of Honey for Off-Site Residents	D–101
TABLE D.3.3–28	Ingestion of Free-Range Steer for an Off-Site Non-Los Alamos County Resident	D–102
TABLE D.3.3–29	Ingestion of Elk for an Off-Site Los Alamos County Resident	D–103
TABLE D.3.3–30	Ingestion of Elk for an Off-Site Non-Los Alamos	D–104
TABLE D.3.3–31	Ingestion of Deer for an Off-Site Los Alamos County Resident	D–105
TABLE D.3.3–32	Ingestion of Deer for an Off-Site Non-Los Alamos County Resident . . .	D–106
TABLE D.3.3–33	Ingestion of Fish for an Off-Site Non-Los Alamos County Resident . . .	D–108
TABLE D.3.3–34	Ingestion of Metals in Bottom-Feeding Fish for an Off-Site Non-Los Alamos County Resident	D–109
TABLE D.3.3–35	Ingestion of Fruits and Vegetables for Off-Site Los Alamos County Residents	D–111
TABLE D.3.3–36	Ingestion of Metals in Homegrown Vegetables for Off-Site Los Alamos County Residents	D–114
TABLE D.3.3–37	Ingestion of Metals in Store Bought Vegetables for Off-Site Los Alamos and Non-Los Alamos County Residents	D–116
TABLE D.3.3–38	Ingestion of Metals in Homegrown Fruit for Off-Site Los Alamos County Residents	D–118
TABLE D.3.3–39	Ingestion of Fruits and Vegetables for Off-Site Non-Los Alamos County Residents	D–120
TABLE D.3.3–40	Ingestion of Metals in Homegrown Vegetables for Off-Site Non-Los Alamos County Residents	D–123
TABLE D.3.3–41	Ingestion of Milk for Off-Site Residents	D–125
TABLE D.3.3–42	Ingestion of Fish for a Special Pathway Receptor	D–127
TABLE D.3.3–43	Ingestion of Metals in Bottom-Feeding Fish for a Special Pathway Receptor	D–128
TABLE D.3.3–44	Ingestion of Elk for a Special Pathway Receptor	D–130
TABLE D.3.3–45	Ingestion of Herbal Tea (Cota) for Special Pathway Receptors	D–131

TABLE D.3.3-46	Ingestion of Radionuclides in Vegetables Grown in Contaminated Soil for Comparison Purposes	D-132
TABLE D.3.3-47	Ingestion of Metals in Vegetables Grown in Contaminated Soil	D-133
TABLE D.3.3-48	Ingestion of Regional Vegetables for Comparison to Table D.3.3-48 . . .	D-134
TABLE D.3.3-49	Ingestion of Metals in LANL On-Site Fruit	D-135
TABLE D.3.3-50	Ingestion of Pinyon Nuts for a Non-Los Alamos County Resident and a Special Pathway Receptor	D-136
TABLE D.3.4-1	Comparison of Concentrations of Selected Radionuclides and Metals in Regional and Perimeter or On-Site Media	D-139
TABLE D.3.5-1	Location of Foodstuffs and Receptors Used for Consequence Analysis (ESH-20 Foodstuffs Database, 1990 to 1994)	D-144
TABLE D.3.5-2	Los Alamos Water Supply Detection Statistics Used in Consequence Analysis (Environmental Surveillance Database, 1991 to 1996)	D-146
TABLE D.3.5-3	Well LA-5 Detection Statistics Used in Consequence Analysis (Environmental Surveillance Database, 1991 to 1996)	D-148
TABLE D.3.5-4	NPDES Analyte Summary Statistics Used in Consequence Analysis (ESH NPDES Data, 1994 to 1996)	D-150
TABLE D.3.5-5	Soil Detection Statistics Used in Consequence Analysis (Environmental Surveillance Soils Data, 1992 to 1996)	D-151
TABLE D.3.5-6	Foodstuffs Used in Consequence Analysis Sorted by Receptor (ESH-20 Foodstuffs Database, 1990 to 1994)	D-155
TABLE D.3.5-7	Free-Range Steer Muscle Radiochemical Summary Statistics Used in Consequence Analysis (ESH-20 Data for 1996)	D-158
TABLE D.3.5-8	Deer Muscle Radiochemical Summary Statistics Used in Consequence Analysis (ESH-20 Data for 1996)	D-159
TABLE D.3.5-9	Analysis of Fish Used in Consequence Analysis (ESH-20 Foodstuffs Database, 1990 to 1994)	D-160
TABLE D.3.5-10	Bottom-Feeding Fish Chemical Summary Statistics Used in Consequence Analysis (ESH-20 Data, 1996)	D-160

TABLE D.3.5-11	Produce Chemical Summary Statistics Used in Consequence Analysis (ESH-20 Data, 1996)	D-161
TABLE D.3.5-12	Bottom-Feeding Fish Regional Statistic Reference Levels Used in Consequence Analysis (ESH-20 Data, 1996)	D-164
TABLE D.3.5-13	Elk Tissue Radiochemical Summary Statistics Used in Consequence Analysis (ESH-20 Data for 1991 to 1993)	D-165
TABLE D.3.5-14	Navajo Tea (Cota) Radiochemical Summary Statistics Used in Consequence Analysis (ESH-20 Data, 1996)	D-166
TABLE D.3.5-15	Edible Portions of Beans, Corn, and Squash Used in Consequence Analysis (ESH-20 Data, 1996)	D-167
TABLE D.3.5-16	Analysis of Pinyon Nuts Used in Consequence Analysis (Salazar 1979)	D-169
TABLE E.3.1-1	Archaeological Periods of Northern New Mexico	E-6
TABLE E.3.3.1-1	Languages of American Indian Communities within the LANL Region	E-12
TABLE E.5.4-1	Potential Impacts of Actions on Prehistoric Resource Types	E-31
TABLE E.5.4-2	Potential Impacts of Actions on Historic Resource Categories	E-32
TABLE E.5.4-3	Potential Impacts of Actions on Traditional Cultural Property Categories	E-34
TABLE E.6.2-1	Prehistoric Cultural Resource Sites Within LANL Boundaries	E-39
TABLE E.6.3-1	Historic Sites Identified by the SWEIS	E-41
TABLE E.6.4-1	Traditional Cultural Properties Identified by Consulting Communities on or near LANL Property	E-42
TABLE F.4.2.1-1	Average Truck Accident Rates	F-22
TABLE F.4.2.2-1	Truck Accident Rates in the Santa Fe to Los Alamos Area (1990 Through 1994)	F-23
TABLE F.4.2.3-1	Truck Accident Rates at the LANL Site	F-23
TABLE F.4.2.4-1	Safe Secure Trailer Accident Rates	F-24
TABLE F.4.3-1	Route Segment Information from I-25 to LANL	F-25

TABLE F.4.4.1-1	Parameter Values for Incident-Free Risk Quantification	F-27
TABLE F.4.4.2-1	Fractional Occurrences for Truck Accidents by Severity Category and Population Density Zone	F-28
TABLE F.4.4.3-1	Estimated Release Fractions for Shipping Packaging Under Various Accident Severity Categories	F-29
TABLE F.4.4.4-1	Estimated Respirable Release Fractions for Shipping Packaging Under Various Accident Severity Categories.	F-30
TABLE F.5.2-1	Summary of Radioactive and Hazardous Material Bounding Off-Site Shipments to and from LANL, 1990 Through 1994	F-34
TABLE F.5.2-2	Annual LANL On-Site and Off-Site Shipments.	F-34
TABLE F.5.3-1	Off-Site Shipments of Radioactive Materials	F-35
TABLE F.5.3-2	On-Site Shipments of Radioactive Materials	F-40
TABLE F.5.3-3	Annual Number of Hazardous Material Truck Shipments for SWEIS Alternatives	F-45
TABLE F.6.1-1	Off-Site Shipment Distance per Trip	F-46
TABLE F.6.2-1	Number of Excess Latent Cancer Fatalities Due to Truck Emissions in Urban Areas	F-46
TABLE F.6.3-1	Annual Truck Accident Fatalities	F-48
TABLE F.6.3-2	Annual Truck Accident Injuries	F-48
TABLE F.6.3-3	Number of Annual Truck Accidents.	F-48
TABLE F.6.4-1	Annual Incident-Free Population Dose and Excess Latent Cancer Fatality for the No Action Alternative	F-49
TABLE F.6.4-2	Annual Incident-Free Population Dose and Excess Latent Cancer Fatality for the Expanded Operations Alternative	F-49
TABLE F.6.4-3	Annual Incident-Free Population Dose and Excess Latent Cancer Fatality for the Reduced Operations Alternative	F-50
TABLE F.6.4-4	Annual Incident-Free Population Dose and Excess Latent Cancer Fatality for the Greener Alternative	F-50

TABLE F.6.4.1-1	Annual Doses and Cancer Risks to Drivers from On-Site Shipment of Radioactive Materials.	F-51
TABLE F.6.4.1-2	Driver Dose Data for On-Site Shipments in 1994	F-52
TABLE F.6.5.2-1	Maximally Exposed Individual Doses and Associated Frequencies for Off-Site Radioactive Materials Accidents	F-56
TABLE F.6.5.2-2	Bounding Radioactive Materials Off-Site Accident Population Risk for the No Action Alternative	F-56
TABLE F.6.5.2-3	Bounding Radioactive Materials Off-Site Accident Population Risk for the Expanded Operations Alternative	F-56
TABLE F.6.5.2-4	Bounding Radioactive Materials Off-Site Accident Population Risk for the Reduced Operations Alternative	F-57
TABLE F.6.5.2-5	Bounding Radioactive Materials Off-Site Accident Population Risk for the Greener Alternative	F-57
TABLE F.6.5.3-1	Exposure Parameters of Bounding Chlorine Accident	F-57
TABLE F.6.5.3-2	Frequencies and Consequences of a Major Chlorine Release	F-59
TABLE F.6.5.3-3	Major Chlorine Accident Risks	F-59
TABLE F.6.5.4-1	Frequencies and Consequences of a Major Propane Release	F-61
TABLE F.6.5.4-2	Major Propane Accident Risk	F-61
TABLE F.6.5.5-1	Maximally Exposed Individual Doses and Frequencies for On-Site Radioactive Materials Accidents	F-62
TABLE F.6.5.5-2	On-Site Radioactive Materials Accident Maximally Exposed Individual Risk	F-62
TABLE F.7.2-1	Comparison of Excess Latent Cancer Fatalities per Year Due to Truck Emissions	F-65
TABLE F.7.2-2	Comparison of Annual Truck Accident Fatalities	F-65
TABLE F.7.2-3	Comparison of Annual Truck Accident Injuries	F-65
TABLE F.7.2-4	Comparison of Number of Annual Truck Accidents	F-65
TABLE F.7.2-5	Comparison of Annual Incident-Free Population Dose for the No Action Alternative	F-66

TABLE F.7.2-6	Comparison of Annual Incident-Free Population Dose for the Expanded Operations Alternative	F-66
TABLE F.7.2-7	Comparison of Annual Incident-Free Population Dose for the Reduced Operations Alternative	F-66
TABLE F.7.2-8	Comparison of Annual Incident-Free Population Dose for the Greener Alternative.	F-67
TABLE F.7.2-9	Comparison of Off-Site Radioactive Materials Release Frequencies	F-67
TABLE F.7.2-10	Comparison of Chlorine and Propane Major Release Frequencies	F-67
TABLE F.7.2-11	Comparison of Bounding Radioactive Material Off-Site Accident Population Risk for the No Action Alternative	F-68
TABLE F.7.2-12	Comparison of Bounding Radioactive Materials Off-Site Accident Population Risk for the Expanded Operations Alternative.	F-68
TABLE F.7.2-13	Comparison of Bounding Radioactive Materials Off-Site Accident Population Risk for the Reduced Operations Alternative.	F-69
TABLE F.7.2-14	Comparison of Bounding Radioactive Materials Off-Site Accident Population Risk for the Greener Alternative	F-69
TABLE F.7.2-15	Comparison of Major Chlorine and Propane Accident Risks for the No Action Alternative	F-71
TABLE F.7.2-16	Comparison of Major Chlorine and Propane Accident Risks for the Expanded Operations Alternative	F-71
TABLE F.7.2-17	Comparison of Major Chlorine and Propane Accident Risks for the Reduced Operations Alternative	F-71
TABLE F.7.2-18	Comparison of Major Chlorine and Propane Accident Risks for the Greener Alternative	F-72
TABLE G.1.5.2-1	Frequency of Some Natural Phenomena Events at LANL.	G-9
TABLE G.3.1-1	Accident Type and Initiating Event Master Classification List	G-17
TABLE G.3.1-2	Accident Type and Accident Initiator Screening Criteria	G-19
TABLE G.3.1-3	Process Hazards Screening Results	G-20
TABLE G.3.1-4	Man-Made Hazards Screening Results.	G-21

TABLE G.3.1-5	Natural Phenomena Hazards Screening Results	G-22
TABLE G.3.1-6	Credible Accident Types and Accident Initiators that Survived Early Screening	G-23
TABLE G.3.2-1	LANL Facilities Identified in Initial Hazard Categorization	G-24
TABLE G.3.2-2	LANL Facilities Screened from Analysis, with Screening Rationale	G-26
TABLE G.3.2-3	Final List of LANL Facilities to be Subjected to Screening Consequence Analysis	G-29
TABLE G.3.3.1-1	Preliminary ALOHA™ Chemical Screening Results.	G-34
TABLE G.3.3.1-2	Preliminary Binning of Chemical Accident Release Sites	G-35
TABLE G.3.3.1-3	Final Chemical Accident Binning.	G-36
TABLE G.3.4.3-1	Consolidated List of Accidents Subjected to Radiological Consequence	G-40
TABLE G.4-1	Risk-Dominant Accidents at LANL	G-45
TABLE G.4.1-1	Accident Annual Frequency Results, by Alternative	G-47
TABLE G.4.1.3-1	Aircraft Crash Rates	G-57
TABLE G.4.1.3-2	Projected LAM Yearly Flight Operations (Year 2003)	G-57
TABLE G.4.1.3-3	LANL Building Dimensions.	G-61
TABLE G.4.1.3-4	Aircraft Operational Data: Takeoff, In Flight, and Landing	G-62
TABLE G.4.1.3-5	Aircraft Crash Frequencies	G-63
TABLE G.4.1.3-6	Aircraft Missile Characteristics	G-64
TABLE G.4.1.3-7	Structural Perforation Calculation Summary	G-65
TABLE G.4.1.3-8	Aircraft Crash Frequencies per Year for Perforation Leading to Explosion	G-66
TABLE G.4.1.3-9	Aircraft Crash Frequency per Year for Perforation Leading to Fire	G-67
TABLE G.4.2.1-1	Summary of Chemical Accident Source Term Calculations	G-70
TABLE G.4.2.2-1	Source Terms of Radiological Accidents at LANL	G-72

TABLE G.5-1	Summary of Consequences from Risk-Significant Accidents at LANL . . .	G-76
TABLE G.5.1-1	Summary of Consequences to Workers at Accident Origination Facilities	G-82
TABLE G.5.4-1	Estimated High Confidence in Low Probability of Failure Capacities of LANL Structures and Internals	G-89
TABLE G.5.4-2	HCLPF Values Versus Annual Frequency of Failure	G-92
TABLE G.5.4-3	Seismic Failures and Failure Frequencies Arrayed in Descending Order	G-93
TABLE G.5.4-4	Identified Site-Wide Earthquakes	G-94
TABLE G.5.4.2-1	Consequences of a Hydrochloric Acid Release	G-99
TABLE G.5.4.4-1	Estimated Inhalation Doses from Resuspension Following Wildfire . . .	G-107
TABLE G.5.4.4-2	Summary Table for Contaminated Soil Areas	G-110
TABLE G.5.4.4-3	Evaluation of Vulnerability of LANL Buildings to Wildfire	G-113
TABLE G.5.4.4-4	Final Vulnerability and Consequence Assessment of Building Wildfires	G-115
TABLE G.5.4.4-5	Consequence Summary for Building Fires	G-119
TABLE G.5.5.6-1	Summary Results for Scenario CHEM-06	G-149
TABLE G.5.6.1-1	Summary Results for Scenario RAD-01	G-155
TABLE G.5.6.1-2	Predicted Mean Doses to MEIs for Scenario RAD-01	G-155
TABLE G.5.6.1-3	Predicted Mean Ground Contamination Levels for Scenario RAD-01 . .	G-155
TABLE G.5.6.2-1	Summary of Results for Scenario RAD-02	G-161
TABLE G.5.6.2-2	Predicted Mean Doses to MEIs for Scenario RAD-02	G-161
TABLE G.5.6.2-3	Predicted Mean Ground Contamination Levels for Scenario RAD-02 . .	G-162
TABLE G.5.6.3-1	Summary Results for Scenario RAD-03	G-168
TABLE G.5.6.3-2	Predicted Mean Doses to MEIs for Scenario RAD-03	G-168
TABLE G.5.6.3-3	Predicted Mean Ground Contamination Levels for Scenario RAD-03 . .	G-169

TABLE G.5.6.4-1	DARHT EIS Hypothetical Impacts to Workers and the Public from Postulated Accidents Involving Plutonium	G-171
TABLE G.5.6.4-2	DARHT EIS Hypothetical Impacts to the Most Populated Sector from Postulated Accidents Involving Plutonium	G-172
TABLE G.5.6.4-3	DARHT EIS Hypothetical Impacts to Nearby Communities from a Postulated Inadvertent Detonation Accident Involving Plutonium	G-172
TABLE G.5.6.5-1	Summary Results for Scenario RAD-05	G-176
TABLE G.5.6.5-2	Predicted Mean Doses to MEIs for Scenario RAD-05	G-176
TABLE G.5.6.6-1	Frequency Weighted Source Term Calculation for Initial Source Term	G-180
TABLE G.5.6.6-2	Frequency Weighted Source Term Calculation for Suspension Source Term	G-180
TABLE G.5.6.6-3	Summary Results for RAD-06	G-181
TABLE G.5.6.7-1	Summary Results for Scenario RAD-07	G-186
TABLE G.5.6.7-2	Predicted Mean Doses to MEIs for Scenario RAD-07	G-186
TABLE G.5.6.7-3	Predicted Mean Ground Contamination Levels for Scenario RAD-07	G-186
TABLE G.5.6.8-1	Characterization of TRU Waste in Pads 1, 2, and 4 at TA-54 Area G	G-187
TABLE G.5.6.8-2	Frequency Weighted Source Term Calculation for Initial Source Term	G-192
TABLE G.5.6.8-3	Frequency Weighted Source Term Calculation for Suspension Source Term	G-193
TABLE G.5.6.8-4	Summary of Results for Scenario RAD-08	G-195
TABLE G.5.6.8-5	Predicted Mean Doses to MEIs for Scenario RAD-08	G-195
TABLE G.5.6.8-6	Predicted Mean Ground Contamination Levels for Scenario RAD-08	G-196
TABLE G.5.6.9-1	Suspension Terms for RAD-09	G-201
TABLE G.5.6.9-2	Consequences for RAD-09, 1-Hour Cleanup	G-201

TABLE G.5.6.9-3	Summary Results for Scenario RAD-09	G-203
TABLE G.5.6.9-4	Predicted Mean Doses to MEIs for Scenario RAD-09	G-204
TABLE G.5.6.9-5	Predicted Mean Ground Contamination Levels for Scenario RAD-09	G-204
TABLE G.5.6.10-1	Summary Results for Scenario RAD-10	G-210
TABLE G.5.6.10-2	Predicted Mean Doses to MEIs for Scenario RAD-10	G-210
TABLE G.5.6.10-3	Predicted Mean Ground Contamination Levels for Scenario RAD-10	G-210
TABLE G.5.6.11-1	Summary Results for Scenario RAD-11	G-212
TABLE G.5.6.12-1	Consequences for Accident Scenario RAD-12	G-215
TABLE G.5.6.12-2	Overall Risks for Accident Scenario RAD-12.	G-215
TABLE G.5.6.12-3	Predicted MEI Doses for Scenario RAD-12	G-215
TABLE G.5.6.13-1	Summary Results for Scenario RAD-13	G-221
TABLE G.5.6.13-2	Predicted Mean Doses to MEIs for Scenario RAD-13	G-221
TABLE G.5.6.13-3	Predicted Mean Ground Contamination Levels for Scenario RAD-13	G-221
TABLE G.5.6.14-1	Accident Progression Associated with Either Occurrence Frequency or Failure Rate	G-224
TABLE G.5.6.14-2	Source Term with Operational HEPA and HVAC Systems.	G-226
TABLE G.5.6.14-3	Suspension Term with Operational HEPA and HVAC Systems	G-227
TABLE G.5.6.14-4	Source Term with Failed HEPA Filters and Operational HVAC Systems.	G-229
TABLE G.5.6.14-5	Suspension Term with Failed HEPA Filters and Operational HVAC Systems.	G-229
TABLE G.5.6.14-6	Source Term with Failed HVAC Fans and Operational HEPA Filters.	G-231
TABLE G.5.6.14-7	Suspension Term with Failed HVAC Fans and Operational HEPA Filters.	G-231

TABLE G.5.6.14-8	Summary of Material Available for Atmospheric Transport	G-231
TABLE G.5.6.14-9	A Result Comparison of the MACCS Runs	G-233
TABLE G.5.6.14-10	Summary Results for RAD-14.	G-233
TABLE G.5.6.14-11	Predicted Mean Doses to MEIs for Scenario RAD-14	G-233
TABLE G.5.6.14-12	Predicted Mean Ground Contamination Levels for Scenario RAD-14	G-234
TABLE G.5.6.15-1	Summary of the Source Term Calculations (No Action Alternative) . . .	G-236
TABLE G.5.6.15-2	Summary of the Suspension Term Calculations (No Action Alternative).	G-238
TABLE G.5.6.15-3	Summary of the Source Term Calculations (Expanded Operations Alternative).	G-240
TABLE G.5.6.15-4	Material-at-Risk (Expanded Operations Alternative).	G-240
TABLE G.5.6.15-5	Damage Ratio (Expanded Operations Alternative)	G-240
TABLE G.5.6.15-6	Airborne Release and Respirable Fraction (Expanded Operations Alternative).	G-241
TABLE G.5.6.15-7	Leak Path Factor (Expanded Operations Alternative)	G-241
TABLE G.5.6.15-8	Summary of Suspension Term Calculations (Expanded Operations Alternative).	G-241
TABLE G.5.6.15-9	Material-at-Risk (Expanded Operations Alternative).	G-242
TABLE G.5.6.15-10	Damage Ratio (Expanded Operations Alternative)	G-242
TABLE G.5.6.15-11	Airborne Release Rate, Release Period, and Respirable Fraction (Expanded Operations Alternative)	G-242
TABLE G.5.6.15-12	Leak Path Factor (Expanded Operations Alternative)	G-243
TABLE G.5.6.15-13	Summary Results for CMR Laboratory Fire, RAD-15	G-244
TABLE G.5.6.15-14	Summary Results for the CMR Wing Fire, RAD-15.	G-244
TABLE G.5.6.15-15	Predicted Mean Doses to MEIs for Scenario RAD-15 (Expanded Operations Alternative).	G-244

TABLE G.5.6.15–16	Ground Contamination Levels (Expanded Operations Alternative)	G–246
TABLE G.5.6.16–1	Source Term for Aircraft Crash	G–247
TABLE G.5.6.16–2	Suspension Term Calculations (No Action Alternative)	G–249
TABLE G.5.6.16–3	Frequency Weighted Source Term Calculation for Fire Source Term . . .	G–252
TABLE G.5.6.16–4	Frequency Weighted Source Term Calculation for Fire Suspension Term.	G–252
TABLE G.5.6.16–5	Summary Results for Scenario RAD–16	G–252
TABLE G.5.6.16–6	Predicted Mean Doses to MEIs for Scenario RAD–16	G–253
TABLE G.5.6.16–7	Predicted Mean Ground Contamination Levels	G–253
TABLE G.5.7.1–1	Blast Effects to Humans Due to Fast-Rising Air Blasts (3 to 5 Minutes Duration)	G–254
TABLE G.5.7.1–2	Summary Results for Scenario WORK–01	G–256
TABLE G.5.7.2–1	Summary Results for Scenario WORK–02	G–258
TABLE G.5.7.3–1	Summary of Inadvertent Solution Criticality Events (1945 to the Present)	G–259
TABLE G.5.7.3–2	Summary Results for Scenario WORK–03	G–262
TABLE G.5.7.4–1	Summary Results for Scenario WORK–04	G–263
TABLE G.5.7.5–1	Frequency Analysis for a Container Drop in TA–55	G–265
TABLE G.5.7.5–2	Number of Container Handling Operations	G–265
TABLE G.5.7.5–3	Human Error Probability (HEP), Container Drop	G–265
TABLE G.5.7.5–4	Probability of Dropping a Degraded Container	G–266
TABLE G.5.7.5–5	Summary Results for Scenario WORK–05	G–267

VOLUME III

ABBREVIATIONS AND ACRONYMS

AAQS	Ambient Air Quality Control Standards
ACHP	Advisory Council on Historic Preservation
ACGIH	American Conference of Governmental Industrial Hygienists
ACIS	Automated Chemical Inventory System
ACL	administrative control level
AEC	U.S. Atomic Energy Commission
AIHA	American Industrial Hygiene Association
AIRFA	<i>American Indian Religious Freedom Act</i>
ALARA	as low as reasonably achievable
ALOHA™	Areal Locations of Hazardous Atmospheres (code)
ANSI	American National Standards Institute
ARF	airborne release fraction
ARMS	Archaeological Records Management System
ARPA	<i>Archaeological Resource Protection Act</i>
ARR	airborne release rate
ARTCC	Air Route Traffic Control Center
BIO	Basis for Interim Operation
BLEVE	boiling liquid expanding vapor explosion
BNL	Brookhaven National Laboratory
BNM	Bandelier National Monument
°C	degrees Celsius
CAA	<i>Clean Air Act</i>
CAM	continuous air monitor

CAP-88	Clean Air Act Assessment Package for 1988
CBD	chronic beryllium disease
CDC	Centers for Disease Control
CDP	Census Designated Place
CDR	Conceptual Design Report
CEDE	committed effective dose equivalent
CEQ	Council on Environmental Quality
CFR	Code of Federal Regulations
CH	contact-handled (waste)
CH TRU	contact-handled transuranic (waste)
cm	centimeter
CMIP	Capability Maintenance and Improvement Project
CMR	Chemistry and Metallurgy Research
CRMT	Cultural Resources Management Team
CSA	Container Storage Area
DARHT	Dual Axis Radiographic Hydrodynamic Test (Facility)
DCG	derived concentration guide
DDE	deep dose equivalent
DNA	deoxyribonucleic acid
DNFSB	Defense Nuclear Facilities Safety Board
DoD	U.S. Department of Defense
DOE	U.S. Department of Energy
DOI	U.S. Department of Interior
DOT	U.S. Department of Transportation
DR	damage ratio

DU	depleted uranium
EA	environmental assessment
ECDR	Enhanced Conceptual Design Report
EIS	environmental impact statement
EM	DOE Office of Environmental Management
EM&R	emergency management and response
EO	Executive Order
EPA	U.S. Environmental Protection Agency
ERPG	Emergency Response Planning Guideline
ES	emission stack
EU	enriched uranium
°F	degrees Fahrenheit
FAA	Federal Aviation Administration
FE	fan exhaust
FEMA	Federal Emergency Management Agency
FIMAD	Facility for Information Management, Analysis and Display
FONSI	Finding of No Significant Impact
FR	<i>Federal Register</i>
FRP	fiberglass-reinforced plastic (or plywood)
FSAR	Final Safety Analysis Report
FS MEI	facility-specific maximally exposed individual
ft	feet
FWS	U.S. Fish and Wildlife Service
FY	fiscal year
g	gram

<i>g</i>	acceleration of gravity (980 cm/sec ²)
GEP	good engineering practice
GIS	geographic information system
GV	guideline value
ha	hectares
HA	hazard analysis
HAP	hazardous air pollutant
HAZMAT	hazardous material
HCLPF	high confidence in low probability of failure
HE	high explosives
HEFS	High Explosives Firing Site
HEPF	High Explosives Processing Facility
HEP	(mean) human error probability
HEPA	high efficiency particulate air (filter)
HEU	highly enriched uranium
HHS	U.S. Department of Health and Human Services
HI	hazard index
HRL	Health Research Laboratory
HVAC	heating, ventilation, and air conditioning
ICBM	intercontinental ballistic missile
ICRP	International Commission on Radiological Protection
IDLH	immediately dangerous to life or health
in.	inch
IP	industrial packaging
IPF	Isotope Production Facility

IRIS	Integrated Risk Information System
ISC-3	Industrial Source Complex (Model) Version 3
km	kilometer
LACEF	Los Alamos Critical Experiments Facility
LAM	Los Alamos Municipal Airport
LAMPF	Los Alamos Meson Physics Facility (former name for LANSCE)
LANL	Los Alamos National Laboratory
LANSCE	Los Alamos Neutron Science Center
LASL	Los Alamos Scientific Laboratory
lb	pound
LCF	latent cancer fatality
LEDA	Low-Energy Demonstration Accelerator
LEL	lower explosive limit
LEU	low enriched uranium
LLMW	low-level mixed waste
LLNL	Lawrence Livermore National Laboratory
LLW	low-level radioactive waste
LPF	leak path factor
LSA	low specific activity
m	meter
MAPs	mixed activation products
MAR	material-at-risk
MC&A	materials control and accountability
MCL	maximum contaminant level
MEI	maximally exposed individual

MFPs	mixed fusion products
MGY	million gallons per year
mi	mile
ML	Richter Magnitude
MLNSC	Manuel Lujan Neutron Scattering Center
MOA	memorandum of agreement
MOI	maximum off-site individual
MOX	mixed oxide (fuel)
MSL	Materials Science Laboratory
NA	not applicable
NAAQS	National Ambient Air Quality Standards
NAGPRA	<i>Native American Graves and Repatriation Act</i>
NASA	National Aeronautics and Space Administration
NATO	North Atlantic Treaty Organization
NCI	National Cancer Institute
NCRP	National Council on Radiation Protection
NDA	nondestructive analysis
NDE	nondestructive examination
NDT	Nondestructive Testing (Facility)
NEPA	<i>National Environmental Policy Act of 1969, as amended</i>
NESHAP	National Emission Standards for Hazardous Air Pollutants
NHPA	<i>National Historic Preservation Act</i>
NIF	National Ignition Facility
NIH	National Institute of Health
NIOSH	National Institute for Occupational Safety and Health

NM	New Mexico
NMAC	New Mexico Administrative Code
NMED	New Mexico Environment Department
NMSA	New Mexico Statutes Annotated
NMSF	Nuclear Materials Storage Facility
NMTR	New Mexico Tumor Registry
NOAA	National Oceanic and Atmospheric Administration
NOI	Notice of Intent
NO _x	nitrogen oxides
NPDES	National Pollutant Discharge Elimination System
NPH	natural phenomena hazard
NPS	National Park Service
NRC	U.S. Nuclear Regulatory Commission
NRDC	National Resources Defense Council
NRHP	National Register of Historic Places
NSC	National Safety Council
NTS	Nevada Test Site
NTU	nephelometric turbidity units
OEL	occupational exposure limit
OLM	Ozone Limiting Method
ORPS	Occurrence Reporting and Processing System
OSHA	Occupational Safety and Health Administration
PCB	polychlorinated biphenyl
PE-Ci	plutonium equivalent curie
PEIS	programmatic environmental impact statement

PF	Plutonium Facility
PGA	peak ground acceleration (horizontal)
pH	a measure of acidity and alkalinity
PHERMEX	Pulsed High-Energy Radiation Machine Emitting X-Ray (facility)
PL	public law
PM	particulate matter
PM 10	particulate matter equal to or less than 10 micrometers aerodynamic diameter
POC	point-of-contact
PPE	personal protective equipment
ppb	parts per billion
ppm	parts per million
PRA	probabilistic risk assessment
PrHA	process hazard analysis
PSHA	Probabilistic Seismic Hazard Analysis
psi	pounds per square inch
R&D	research and development
RAM	radioactive material
RAMROD	Radioactive Materials Research, Operations, and Demonstration (facility)
RANT	Radioactive Assay and Nondestructive Test (facility)
RAP	regulated air pollutant
RCRA	<i>Resource Conservation and Recovery Act</i>
rem	roentgen equivalent man
RF	radio frequency
RfCs	inhalation reference concentrations
RfD	reference dose

RFETS	Rocky Flats Environmental Technology Site
RFP	Rocky Flats Plant (former name of the Rocky Flats Environmental Technology Site)
RH	remote-handled (waste)
RH TRU	remote-handled transuranic (waste)
RLW	radioactive liquid waste
RLWTF	Radioactive Liquid Waste Treatment Facility
RMP	Risk Management Program (EPA)
ROD	Record of Decision
SA	safety assessment
SAR	Safety Analysis Report
SCAPA	Subcommittee of Consequence Analysis and Protective Actions (DOE)
SCO	surface-contaminated object
SEER	Surveillance, Epidemiology, and End Results
SHEBA	Solution High-Energy Burst Assembly
SHPO	State Historic Preservation Office(r)
SLEV	screening level emission value
SMAC	shipment mobility/accountability collection
SNL	Sandia National Laboratories
SNM	special nuclear material
SPCC	Spill Prevention, Control, and Countermeasures
SRS	Savannah River Site
SSM	Stockpile Stewardship and Management
SST	safe secure transport
START	Strategic Arms Reduction Talks (or Treaty)
STC	standard transportation container

SWB	standard waste box
SWSC	sanitary waste system consolidation
TA	Technical Area
TCP	traditional cultural property
TEDE	total effective dose equivalent
TEEL	temporary emergency exposure limit
TFF	Target Fabrication Facility
TI	transport index
TLV	threshold limit value
TRU	transuranic (waste)
TRUPACT	Transuranic Packaging Transporter
TSFF	Tritium Science and Fabrication Facility
TSP	total suspended particulates
TSTA	Tritium System Test Assembly (facility)
TWA	time-weighted average
TWISP	Transuranic Waste Inspectable Storage Project
UBC	Uniform Building Code
UC	University of California
UCL	upper confidence limit
UCNI	unclassified controlled nuclear information
UCRL	University of California Research Laboratory
UN	University of Nevada
UNM	University of New Mexico
URF	unit risk factor
U.S.	United States

U.S.C.	United States Code
USDA	U.S. Department of Agriculture
USFS	U.S. Forest Service
USGS	U.S. Geological Survey
USSR	Union of Soviet Socialist Republics
VOC	volatile organic compound
WAC	waste acceptance criteria
WCRR	Waste Characterization, Reduction, and Repackaging (facility)
WETF	Weapons Engineering Tritium Facility
WIPP	Waste Isolation Pilot Plant
WNR	Weapons Neutron Research
WWTF	Waste Water Treatment Facility

VOLUME III

MEASUREMENTS AND CONVERSIONS

The following information is provided to assist the reader in understanding certain concepts in this SWEIS. Definitions of technical terms can be found in volume I, chapter 10, Glossary.

SCIENTIFIC NOTATION

Scientific notation is used in this report to express very large or very small numbers. For example, the number 1 billion could be written as 1,000,000,000 or, using scientific notation, as 1×10^9 . Translating from scientific notation to a more traditional number requires moving the decimal point either right (for a positive power of 10) or left (for a negative power of 10). If the value given is 2.0×10^3 , move the decimal point three places (insert zeros if no numbers are given) to the right of its current location. The result would be 2,000. If the value given is 2.0×10^{-5} , move the decimal point five places to the left of its present location. The result would be 0.00002. An alternative way of expressing numbers, used primarily in the appendixes of this SWEIS, is exponential notation, which is very similar in use to scientific notation. For example, using the scientific notation for 1×10^9 , in exponential notation the 10^9 (10 to the power of 9) would be replaced by E+09. (For positive powers, sometimes the “+” sign is omitted, and so the example here could be expressed as E09.) If the value is given as 2.0×10^{-5} in scientific notation, then the equivalent exponential notation is 2.0E-05.

UNITS OF MEASUREMENT

The primary units of measurement used in this report are English units with metric equivalents enclosed in parentheses.

Many metric measurements presented include prefixes that denote a multiplication factor that is applied to the base standard (e.g., 1 kilometer = 1,000 meters). The following list presents these metric prefixes:

giga	1,000,000,000 (10^9 ; E+09; one billion)
mega	1,000,000 (10^6 ; E+06; one million)
kilo	1,000 (10^3 ; E+03; one thousand)
hecto	100 (10^2 ; E+02; one hundred)
deka	10 (10^1 ; E+01; ten)
unit	1 (10^0 ; E+00; one)
deci	0.1 (10^{-1} ; E-01; one tenth)
centi	0.01 (10^{-2} ; E-02; one hundredth)
milli	0.001 (10^{-3} ; E-03; one thousandth)

micro	0.000001 (10^{-6} ; E-06; one millionth)
nano	0.000000001 (10^{-9} ; E-09; one billionth)
pico	0.000000000001 (10^{-12} ; E-12; one trillionth)

DOE Order 5900.2A, *Use of the Metric System of Measurement*, prescribes the use of this system in DOE documents. Table MC-1 lists the mathematical values or formulas needed for conversion between English and metric units. Table MC-2 summarizes and defines the terms for units of measure and corresponding symbols found throughout this report.

RADIOACTIVITY UNIT

Part of this report deals with levels of radioactivity that might be found in various environmental media. Radioactivity is a property; the amount of a radioactive material is usually expressed as “activity” in curies (Ci) (Table MC-3). The curie is the basic unit used to describe the amount of substance present, and concentrations are generally expressed in terms of curies per unit of mass or volume. One curie is equivalent to 37 billion disintegrations per second or is a quantity of any radionuclide that decays at the rate of 37 billion disintegrations per second. Disintegrations generally include emissions of alpha or beta particles, gamma radiation, or combinations of these.

RADIATION DOSE UNITS

The amount of ionizing radiation energy received by a living organism is expressed in terms of radiation dose. Radiation dose in this report is usually expressed in terms of effective dose equivalent and reported numerically in units of rem (Table MC-4). Rem is a term that relates ionizing radiation and biological effect or risk. A dose of 1 millirem (0.001 rem) has a biological effect similar to the dose received from about a 1-day exposure to natural background radiation. A list of the radionuclides discussed in this document and their half-lives is included in Table MC-5.

CHEMICAL ELEMENTS

A list of selected chemical elements, chemical constituents, and their nomenclature is presented in Table MC-6.

TABLE MC-1.—Conversion Table

MULTIPLY	BY	TO OBTAIN	MULTIPLY	BY	TO OBTAIN
ac	0.405	ha	ha	2.47	ac
°F	$(^{\circ}\text{F} - 32) \times 5/9$	°C	°C	$(^{\circ}\text{C} \times 9/5) + 32$	°F
ft	0.305	m	m	3.28	ft
ft ²	0.0929	m ²	m ²	10.76	ft ²
ft ³	0.0283	m ³	m ³	35.3	ft ³
gal.	3.785	l	l	0.264	gal.
in.	2.54	cm	cm	0.394	in.
lb	0.454	kg	kg	2.205	lb
mCi/km ²	1.0	nCi/m ²	nCi/m ²	1.0	mCi/km ²
mi	1.61	km	km	0.621	mi
mi ²	2.59	km ²	km ²	0.386	mi ²
mi/h	0.447	m/s	m/s	2.237	mi/h
nCi	0.001	pCi	pCi	1,000	nCi
oz	28.35	g	g	0.0353	oz
pCi/l	10 ⁻⁹	μCi/ml	μCi/ml	10 ⁹	pCi/l
pCi/m ³	10 ⁻¹²	Ci/m ³	Ci/m ³	10 ¹²	pCi/m ³
pCi/m ³	10 ⁻¹⁵	mCi/cm ³	mCi/cm ³	10 ¹⁵	pCi/m ³
ppb	0.001	ppm	ppm	1,000	ppb
ton	0.907	metric ton	metric ton	1.102	ton

TABLE MC-2.—Names and Symbols for Units of Measure

LENGTH	
SYMBOL	NAME
cm	centimeter (1×10^{-2} m)
ft	foot
in.	inch
km	kilometer (1×10^3 m)
m	meter
mi	mile
mm	millimeter (1×10^{-3} m)
μm	micrometer (1×10^{-6} m)
VOLUME	
SYMBOL	NAME
cm^3	cubic centimeter
ft^3	cubic foot
gal.	gallon
in.^3	cubic inch
l	liter
m^3	cubic meter
ml	milliliter (1×10^{-3} l)
ppb	parts per billion
ppm	parts per million
yd^3	cubic yard
RATE	
SYMBOL	NAME
Ci/yr	curies per year
cm^3/s	cubic meters per second
ft^3/s	cubic feet per second
ft^3/min	cubic feet per minute
gpm	gallons per minute
kg/yr	kilograms per year
km/h	kilometers per hour
mg/l	milligrams per liter
MGY	million gallons per year
MLY	million liters per year
m^3/yr	cubic meters per year
mi/h or mph	miles per hour
$\mu\text{Ci}/\text{l}$	microcuries per liter
pCi/l	picocuries per liter

TABLE MC-2.—Names and Symbols for Units of Measure-Continued

NUMERICAL RELATIONSHIPS	
SYMBOL	MEANING
<	less than
\leq	less than or equal to
>	greater than
\geq	greater than or equal to
2σ	two standard deviations
TIME	
SYMBOL	NAME
d	day
h	hour
min	minute
nsec	nanosecond
s	second
yr	year
AREA	
SYMBOL	NAME
ac	acre ($640 \text{ per } \text{mi}^2$)
cm^2	square centimeter
ft^2	square foot
ha	hectare ($1 \times 10^4 \text{ m}^2$)
in.^2	square inch
km^2	square kilometer
mi^2	square mile
MASS	
SYMBOL	NAME
g	gram
kg	kilogram (1×10^3 g)
mg	milligram (1×10^{-3} g)
μg	microgram (1×10^{-6} g)
ng	nanogram (1×10^{-9} g)
lb	pound
ton	metric ton (1×10^6 g)
oz	ounce

TABLE MC-2.—Names and Symbols for Units of Measure-Continued

TEMPERATURE	
SYMBOL	NAME
°C	degrees Celsius
°F	degrees Fahrenheit
°K	degrees Kelvin
SOUND/NOISE	
SYMBOL	NAME
dB	decibel
dBA	A-weighted decibel

TABLE MC-4.—Names and Symbols for Units of Radiation Dose

RADIATION DOSE	
SYMBOL	NAME
mrاد	millirad (1×10^{-3} rad)
mrem	millirem (1×10^{-3} rem)
R	roentgen
mR	milliroentgen (1×10^{-3} R)
μR	microroentgen (1×10^{-6} R)

TABLE MC-3.—Names and Symbols for Units of Radioactivity

RADIOACTIVITY	
SYMBOL	NAME
Ci	curie
cpm	counts per minute
mCi	millicurie (1×10^{-3} Ci)
μCi	microcurie (1×10^{-6} Ci)
nCi	nanocurie (1×10^{-9} Ci)
pCi	picocurie (1×10^{-12} Ci)

TABLE MC-5.—Radionuclide Nomenclature

SYMBOL	RADIONUCLIDE	HALF-LIFE	SYMBOL	RADIONUCLIDE	HALF-LIFE
Am-241	americium-241	432 yr	Pu-241	plutonium-241	14.4 yr
H-3	tritium	12.26 yr	Pu-242	plutonium-242	3.8 x 10 ⁵ yr
Mo-99	molybdenum-99	66 hr	Pu-244	plutonium-244	8.2 x 10 ⁷ yr
Pa-234	protactinium-234	6.7 hr	Th-231	thorium-231	25.5 hr
Pa-234m	protactinium-234m	1.17 min	Th-234	thorium-234	24.1 d
Pu-236	plutonium-236	2.9yr	U-234	uranium-234	2.4 x 10 ⁵ yr
Pu-238	plutonium-238	87.7 yr	U-235	uranium-234	7 x 10 ⁸ yr
Pu-239	plutonium-239	2.4 x 10 ⁴ yr	U-238	uranium-238	4.5 x 10 ⁹ yr
Pu-240	plutonium-240	6.5 x 10 ³ yr			

TABLE MC-6.—Elemental and Chemical Constituent Nomenclature

SYMBOL	CONSTITUENT	SYMBOL	CONSTITUENT
Ag	silver	Pa	protactinium
Al	aluminum	Pb	lead
Ar	argon	Pu	plutonium
B	boron	SF ₆	sulfur hexafluoride
Be	beryllium	Si	silicon
CO	carbon monoxide	SO ₂	sulfur dioxide
CO ₂	carbon dioxide	Ta	tantalum
Cu	copper	Th	thorium
F	fluorine	Ti	titanium
Fe	iron	U	uranium
Kr	krypton	V	vanadium
N	nitrogen	W	tungsten
Ni	nickel	Xe	xenon
NO ₂ ⁻	nitrite ion	Zn	zinc
NO ₃ ⁻	nitrate ion		

VOLUME III

A

Accord Pueblos

E-25, E-40

Acid Canyon

C-131 to C-132, C-142 to C-143,
G-107 to G-108, G-110 to G-111

adverse effect(s)

D-8, E-22, E-27, E-30, E-38, G-121

ambient air quality standards (AAQS)

B-38, B-52 to B-54

americium

B-13, C-8, C-10, C-13, C-16, C-18,
C-20 to C-21, C-23, C-25, C-28, C-30,
C-32, C-34, C-36, C-39 to C-40, C-42,
C-44 to C-46, C-48 to C-49,
C-51 to C-53, C-55 to C-56,
C-58 to C-59, C-61, C-63, C-68, C-70,
C-73, C-75, C-77, C-80, C-82, C-85,
C-87, C-90, C-94, C-97, C-99, C-101,
C-131 to C-132, C-136, C-139,
C-142 to C-143, C-145, C-151, C-154,
C-160 to C-161, D-46, D-48, D-50, D-54,
D-58, D-61, D-65, D-75, D-79, D-83,
D-87, D-91, D-96, D-102,
D-105 to D-106, D-131 to D-132, D-146,
D-148, D-151 to D-153, D-158 to D-159,
D-166 to D-167, F-5, F-12, G-74, G-109,
G-124, G-151, G-197

Ancho Canyon

C-105 to C-106, C-132 to C-134

archaeological

E-1 to E-2, E-4 to E-7, E-11,
E-14 to E-15, E-24 to E-26, E-29, E-31,
E-38 to E-40, E-42 to E-43,
E-47 to E-48, E-51 to E-52,
E-55 to E-56, G-123

Area G

B-4, B-13, B-18 to B-20, B-22 to B-25,
D-41, G-45, G-91, G-95 to G-96, G-99,

G-114, G-118, G-123, G-131,
G-144 to G-145, G-152 to G-153, G-182,
G-184 to G-185, G-187 to G-189, G-192,
G-194 to G-198, G-204, G-274 to G-275

Area L

G-34, G-139, G-142, G-146

ARIES

G-80, G-275

Atlas

E-11, E-49

Atomic Energy Act

D-8

B

Bandelier National Monument (BNM)

B-54, B-73 to B-74, B-222 to B-223,
B-225, E-1 to E-2, E-7, E-9,
E-42 to E-44, G-39, G-100,
G-103 to G-104, G-123, G-278

Bandelier Tuff

A-18

Basis for Interim Operation (BIO)

G-39, G-117, G-245, G-276

beryllium

B-11, B-46 to B-47, B-69, B-96, B-127,
B-130 to B-131, B-138 to B-139, B-144,
B-147, B-149, B-151 to B-153,
B-155 to B-156, B-159, B-182,
B-185 to B-187, B-229, B-231 to B-238,
B-245 to B-246, C-8, C-10, C-13, C-18,
C-20 to C-21, C-25, C-28, C-30, C-32,
C-34, C-36, C-39 to C-40, C-42,
C-44 to C-46, C-48 to C-49,
C-51 to C-53, C-55 to C-56,
C-58 to C-59, C-61, C-63, C-68, C-73,
C-75, C-77, C-82, C-85, C-87, C-91,
C-95, C-97, C-99, C-131 to C-132,
C-135 to C-136, C-138 to C-139,

C-142 to C-143, C-145, C-147,
 C-149 to C-150, C-152 to C-154, C-156,
 C-158, C-160 to C-161, D-37 to D-39,
 D-42 to D-44, D-52, D-78, D-90, D-136,
 D-139 to D-141, D-146, D-151 to D-152,
 D-154, D-160 to D-164, D-169 to D-170,
 F-38, G-24, G-26, G-109 to G-111,
 G-116

C

Capability Maintenance and Improvement Project (CMIP)

G-276

census tracts

D-25, D-27

cesium

B-64, B-83, C-8, C-11, C-13, C-16, C-18,
 C-21, C-23, C-25, C-28, C-30, C-32,
 C-34, C-36, C-39 to C-40, C-42,
 C-44 to C-45, C-47 to C-49,
 C-51 to C-52, C-54 to C-55,
 C-57 to C-59, C-61, C-64, C-69, C-71,
 C-73, C-75, C-78, C-80, C-82, C-85,
 C-87, C-91, C-95, C-97, C-100, C-102,
 C-131 to C-132, C-135 to C-138, C-140,
 C-142, C-144, C-146, C-148 to C-149,
 C-152 to C-153, C-155, C-157,
 C-159 to C-160, C-162, D-48, D-50,
 D-54, D-58, D-61, D-65, D-75, D-79,
 D-83, D-87, D-91, D-96,
 D-102 to D-105, D-108, D-111, D-113,
 D-120, D-122, D-125, D-127,
 D-130 to D-132, D-136, D-139 to D-140,
 D-146, D-148, D-151 to D-153,
 D-155 to D-160, D-165 to D-167, D-169,
 G-109, G-124, G-279

classified

B-64, B-81, D-10, E-7, E-10, E-26, E-42,
 F-3, F-15 to F-16, F-33, G-63,
 G-169 to G-170, G-211, G-214

Clean Air Act (CAA)

B-4, B-38 to B-39, B-49, B-143, B-158,
 B-160, D-10

CMR Building

B-4 to B-5, B-144, B-156, D-47 to D-48,
 G-29, G-49, G-68, G-77, G-80, G-83,
 G-85 to G-89, G-94 to G-96, G-100,
 G-143, G-154, G-156 to G-158, G-160,
 G-222, G-232, G-234 to G-237, G-239,
 G-245, G-247 to G-248

CMR Building Upgrades

G-271

collective dose

B-1, B-27 to B-28, D-3, D-33 to D-35,
 F-20, F-47, F-51 to F-53

committed effective dose equivalent (CEDE)

B-1, B-4 to B-5, B-17, D-3, D-6, D-33,
 G-115, G-119

criteria pollutant

B-38, B-40 to B-41, B-49 to B-50,
 B-53 to B-54, B-203 to B-205,
 B-207 to B-209, B-212 to B-213,
 B-215 to B-219, B-222 to B-223, B-228

cultural resource

E-1 to E-4, E-13, E-21 to E-22,
 E-24 to E-30, E-39 to E-40,
 E-48 to E-53, G-121 to G-122

D

decontamination and decommissioning (D&D)

B-3, E-2, E-52, F-5, G-27, G-115, G-139

Defense Nuclear Facilities Safety Board (DNFSB)

G-205 to G-206, G-263, G-269

depleted uranium (DU)

B-7, B-46 to B-47, B-229,
 B-231 to B-235, B-237, D-7,
 D-42 to D-44, F-5, F-37 to F-38,
 F-42 to F-43, F-55, G-26 to G-28, G-31,
 G-40 to G-41, G-107, G-109 to G-110,
 G-115, G-124

derived concentration guide (DCG)

D-46

- design basis accident (DBA)
G-197, G-216
- Diamond Drive
F-22, F-25, G-77, G-161, G-244, G-253
- disassembly
F-35, G-222, G-251, G-271
- disposal cell
B-40
- dome
F-8, F-12, G-24, G-28 to G-29, G-41,
G-46, G-64, G-78, G-90, G-93, G-95,
G-100, G-103, G-117, G-121, G-125,
G-139, G-185, G-187 to G-191, G-193,
G-197
- drinking water
A-14, D-46 to D-47, D-141
- Dual Axis Radiographic Hydrodynamic Test
(DARHT) Facility
F-53 to F-54, F-62, F-75, G-14,
G-25 to G-27, G-29, G-40, G-45, G-61,
G-63, G-65 to G-67, G-74, G-78 to G-79,
G-81, G-84 to G-85, G-89, G-124,
G-167, G-169 to G-174, G-209,
G-211 to G-212, G-270
- E**
-
- earthquake
G-1, G-4, G-9, G-16 to G-18,
G-22 to G-23, G-40, G-44, G-46,
G-49 to G-50, G-69, G-76, G-82,
G-87 to G-91, G-94 to G-96,
G-98 to G-100, G-117 to G-118,
G-212 to G-213
- electric power
G-272
- emergency preparedness
G-202, G-230, G-277
- environmental restoration (ER)
B-55, B-57, B-60 to B-61, C-1, C-104,
C-130 to C-131, C-163 to C-164, D-143,
E-27, E-52, G-123, G-278
EPA D-43 to D-44
- epidemiological
D-12, D-141
- Española
A-1, A-10 to A-11, A-14 to A-15, A-17,
B-73, D-116, D-145, E-29, G-39,
G-171 to G-172, G-268
- Executive Order(s)
E-24, E-30, E-38
- Expanded Operations
A-2, A-12 to A-13, B-6 to B-15, B-21,
B-23, B-26, B-27, B-28, B-31, B-35,
B-41 to B-42, B-54, B-144, B-183,
B-232 to B-233, B-234, B-239, D-35,
D-39 to D-44, F-44, G-5, G-47, G-74,
G-81, G-89, G-126 to G-127, G-132,
G-134, G-137 to G-138, G-141, G-145,
G-147, G-152, G-155, G-157, G-161,
G-165, G-168, G-170, G-174, G-176,
G-181, G-183, G-186, G-189, G-195,
G-198 to G-199, G-203, G-210 to G-213,
G-215, G-217, G-221, G-226, G-233,
G-236, G-238 to G-246, G-250, G-252,
G-254, G-256 to G-258, G-261 to G-263,
G-266 to G-267
- F**
-
- firing site
A-2 to A-3, B-2, B-4, B-12,
B-18 to B-20, B-22 to B-28, B-40, B-46,
B-229, G-27, G-103, G-107 to G-111,
G-124, G-170, G-272, G-275
- fission
B-6, B-10, B-16, D-3, D-7, G-9, G-74,
G-86, G-163, G-166, G-168, G-214,
G-216, G-219, G-258 to G-259,
G-261 to G-262
- fusion
F-38, G-14

G

Greener

A-2, A-12 to A-13, A-15, B-6 to B-15,
B-25 to B-28, B-33, B-37, D-35,
D-39 to D-43, F-1, F-35, F-40,
F-44 to F-48, F-50 to F-51, F-57, F-59,
F-61 to F-65, F-67, F-69, F-72, G-5,
G-47, G-81, G-126 to G-127, G-134,
G-138, G-141, G-145, G-147, G-152,
G-155, G-157, G-161, G-165, G-168,
G-170, G-174, G-176, G-181, G-183,
G-186, G-189, G-195, G-199, G-203,
G-210 to G-213, G-215, G-217, G-221,
G-226, G-233, G-236, G-243 to G-245,
G-250, G-252, G-255 to G-258,
G-261 to G-263, G-266 to G-267

H

hazard index

D-29, D-40, D-43 to D-44, D-55, D-56,
D-59, D-62, D-67, D-70, D-73, D-77,
D-81, D-85, D-89, D-93 to D-94,
D-98 to D-99, D-109, D-114, D-116,
D-118, D-123, D-133 to D-135, G-33

hazardous air pollutant (HAP)

B-26, B-215 to B-216, B-224, B-260

hazardous waste

E-13, F-63, G-34, G-139

health effect

B-41, B-143, D-1, D-4 to D-5, D-7, D-9,
D-170, F-16, F-18 to F-20, F-55, F-58,
F-70, F-73, G-1, G-8, G-10 to G-12,
G-39, G-74, G-100, G-130, G-139,
G-142, G-146, G-148

high explosives (HE)

A-2 to A-3, A-5, A-11, B-4, B-8,
B-18 to B-20, B-22 to B-26,
B-40 to B-41, B-45 to B-46,
B-203 to B-204, B-206 to B-213,
B-215 to B-229, B-231, B-235 to B-238,
D-39, D-41 to D-44, D-141 to D-142,
E-10, G-14 to G-15, G-17 to G-18,

G-24 to G-25, G-27, G-42 to G-43, G-64,
G-80, G-85, G-167, G-212 to G-213,
G-251, G-254 to G-255

highly enriched uranium (HEU)

D-7, F-36 to F-37, F-39 to F-42, G-27,
G-31, G-40, G-45, G-72 to G-74, G-78,
G-84, G-91, G-162, G-166 to G-169,
G-216

historic resource

E-2, E-26, E-29 to E-30, E-32, E-39,
G-122

hot cell

F-43, G-28

human health

D-40, D-42

Hydrogeologic Workplan

A-1, A-17

I

index

A-1 to A-2, A-5, B-230, D-29, D-33,
F-26, G-108

infrastructure

E-10, E-27, E-40, G-5

L

latent cancer fatality(ies) (LCF)

B-1, D-28 to D-29, D-34 to D-35, D-40,
F-30 to F-31, F-45 to F-47, F-49 to F-51,
F-53, F-55 to F-57, F-62, F-64 to F-65,
F-68 to F-69, G-8, G-215

Los Alamos Canyon

C-111 to C-116, C-139 to C-145, D-30,
D-45 to D-46, D-132 to D-133, D-171,
G-101, G-107 to G-108, G-110 to G-111

Los Alamos County

A-11, A-13, B-39, D-11 to D-12, D-14,
D-16, D-18 to D-27, D-50 to D-51,
D-58 to D-59, D-101 to D-103,

D-105 to D-106, D-108 to D-109, D-111,
D-114, D-116, D-118, D-120, D-123,
D-125, D-136, D-141 to D-142,
D-152 to D-153, D-155 to D-156,
D-159 to D-162, D-169 to D-170, E-2,
E-10 to E-11, E-53, E-56, G-36, G-118,
G-120, G-125, G-256

Los Alamos Neutron Science Center
(LANSCE)

A-2 to A-3, A-5, B-2 to B-4,
B-13 to B-16, B-18 to B-20,
B-22 to B-28, B-243, D-29,
D-33 to D-34, D-41, D-45, F-60, G-25,
G-28

low-level radioactive mixed waste (LLMW)
F-63, F-72, G-183

low-level radioactive waste (LLW)
D-45, F-44, F-63, F-72, G-198 to G-199,
G-274

M

main aquifer

C-73 to C-75

maximally exposed individual (MEI)

B-1 to B-3, B-16 to B-29, D-29, D-32,
D-40 to D-43, D-44, D-143, F-20, F-47,
F-56, F-62, G-14, G-31, G-76 to G-81,
G-96, G-98, G-100, G-111,
G-116 to G-119, G-125, G-154 to G-155,
G-160 to G-161, G-167 to G-168,
G-170 to G-171, G-175 to G-176, G-180,
G-185 to G-186, G-194 to G-195, G-202,
G-204, G-206, G-209 to G-212,
G-214 to G-215, G-220 to G-222,
G-232 to G-233, G-243 to G-245, G-251,
G-253

medical isotope

F-20, F-38

Melcor Accident Consequence Code System
(MACCS)

G-12 to G-13, G-37, G-111, G-120,
G-124, G-171, G-214, G-232 to G-233,

G-243, G-251, G-279

Mesita del Buey

E-52, E-56

Mexican spotted owl

G-122

minority population

G-171, G-173

mitigation(s)

E-28 to E-29, E-38, G-5, G-7, G-16,
G-31, G-75, G-123

mixed oxide (MOX)

F-35, F-39, F-41

Mortandad Canyon

C-116 to C-118, C-122 to C-124,
C-145 to C-147, C-154 to C-156,
D-46 to D-47, D-144, G-101,
G-107 to G-108, G-110 to G-111

N

National Ambient Air Quality Standards
(NAAQS)

B-38, B-49, B-52, B-204 to B-205,
B-208, B-213, B-217, B-228, B-255,
B-257

National Emission Standards for Hazardous Air
Pollutants (NESHAP)

B-1, B-4, B-21, B-26

National Pollutant Discharge Elimination
System (NPDES)

A-1 to A-2, A-5, A-17, C-1, C-3, C-164,
D-30, D-46, D-69 to D-70, D-72 to D-73,
D-138, D-150

National Register of Historic Places (NRHP)

E-2 to E-3, E-21 to E-24, E-25, E-27,
E-38 to E-41

natural gas

B-49 to B-51, B-55, B-57, B-62, G-18,
G-40, G-45, G-77, G-83, G-89, G-154,
G-156 to G-158

New Mexico Environment Department
(NMED)

B-39

nitrate(s)

C-9, C-12, C-14, C-17, C-19, C-22, C-24,
C-26, C-31, C-33, C-35, C-37, C-65,
C-69, C-71, C-74, C-76, C-79, C-81,
C-83, C-86, C-89, C-92, C-96, C-98,
C-100, C-102, D-46, D-147, D-149,
G-220, G-226 to G-232

No Action

A-2, A-12 to A-13, A-15, B-6 to B-15,
B-22, B-26 to B-28, B-30, B-34,
B-232 to B-234, D-39, D-41 to D-43,
D-45, F-1, F-33, F-35, F-40 to F-41,
F-44 to F-49, F-51, F-56, F-59,
F-61 to F-66, F-68, F-71, G-5, G-31,
G-47, G-81, G-126 to G-127,
G-131 to G-132, G-134, G-136, G-138,
G-140 to G-143, G-147, G-151, G-155,
G-157, G-161, G-163 to G-165,
G-168 to G-169, G-174, G-176, G-179,
G-181, G-183, G-186, G-188, G-193,
G-195, G-197 to G-199, G-203, G-206,
G-210 to G-216, G-219, G-221, G-223,
G-226, G-233 to G-234, G-236 to G-238,
G-243 to G-245, G-247, G-249, G-252,
G-254 to G-258, G-261 to G-264,
G-266 to G-267

nonproliferation

G-5

Nuclear Materials Storage Facility (NMSF)

F-33, G-28

O

Occupational Safety and Health Administration
(OSHA)

D-1 to D-2, D-9 to D-11, D-36 to D-38,
D-173, G-42, G-107, G-135

Otowi

A-4, A-15 to A-16, B-73, D-31, D-147,
E-6 to E-7, E-54

P

Pajarito Canyon

B-74, C-118 to C-119, C-122,
C-124 to C-126, C-147 to C-149,
C-153 to C-154, C-156 to C-160, G-101

Pajarito Mesa

D-147

Pajarito Road

B-251, G-77 to G-79, G-101, G-103,
G-117, G-119 to G-120, G-123, G-155,
G-168, G-186, G-195, G-204, G-210,
G-120, G-221, G-233

peregrine falcon

G-122

pit

B-215 to B-228, E-6 to E-7, F-35, G-26,
G-51, G-222, G-271

pit manufacturing

F-43, G-50, H-1

pit production

G-14, G-51, G-55, G-261

plume

B-4, B-50 to B-51, B-75, B-183, B-185,
B-189, B-230, B-239, B-243, B-245,
B-247, B-251, B-255, E-19, F-58, F-60,
G-7 to G-8, G-11 to G-13, G-35, G-69,
G-75, G-83 to G-85, G-101,
G-105 to G-106, G-108, G-111,
G-115 to G-116, G-118 to G-119,
G-123 to G-124, G-128, G-130, G-135,
G-157, G-171, G-212, G-214, G-279

plutonium

A-2, B-4 to B-6, B-10 to B-11, B-13,
B-18 to B-20, B-22 to B-26, B-247, C-9,
C-12, C-14, C-17, C-19 to C-20, C-22,
C-24, C-27, C-29, C-31, C-33, C-35,
C-37, C-40 to C-41, C-43, C-45 to C-47,
C-49 to C-51, C-53 to C-54,
C-56 to C-57, C-59 to C-60, C-62, C-66,
C-70, C-72, C-74, C-76, C-79, C-81,
C-84, C-86, C-89, C-93, C-96, C-98,
C-101, C-103, C-131, C-133,
C-137 to C-138, C-140, C-143 to C-144,

- C-146, C-148, C-150, C-152, C-155,
C-157, C-159, C-161 to C-162, D-3, D-7,
D-33, D-35, D-45, D-50, D-54, D-58,
D-61, D-65, D-75, D-79, D-83, D-87,
D-91, D-96, D-102 to D-105, D-108,
D-111, D-120, D-122, D-125, D-127,
D-130, D-132, D-136, D-138 to D-140,
F-5, F-12 to F-13, F-28 to F-30, F-33,
F-35 to F-36, F-38 to F-41, F-43,
F-53 to F-54, F-62 to F-63, F-76, G-1,
G-5, G-9, G-15, G-24, G-27 to G-29,
G-31, G-40, G-45 to G-46, G-50 to G-51,
G-53 to G-55, G-59, G-67 to G-69,
G-74 to G-75, G-161 to G-162,
G-171 to G-172, G-186 to G-187,
G-196 to G-197, G-199, G-205 to G-214,
G-216 to G-222, G-224, G-226 to G-232,
G-234 to G-237, G-239 to G-243,
G-245 to G-253, G-258 to G-261,
G-263 to G-264, G-266 to G-267,
G-271 to G-272, G-279
- plutonium-238
C-9, C-12, C-14, C-17, C-19 to C-20,
C-22, C-24, C-27, C-29, C-31, C-33,
C-35, C-37, C-40 to C-41, C-43,
C-45 to C-47, C-49 to C-51,
C-53 to C-54, C-56 to C-57,
C-59 to C-60, C-62, C-66, C-70, C-72,
C-74, C-76, C-79, C-81, C-83, C-86,
C-89, C-93, C-96, C-101 to C-102,
C-131, C-133, C-137 to C-138, C-140,
C-144, C-146, C-148, C-150, C-152,
C-155, C-157, C-159, C-161 to C-162,
D-46, D-50, D-54, D-58, D-61, D-65,
D-75, D-79, D-83, D-87, D-91, D-96,
D-102 to D-106, D-108, D-111, D-113,
D-120, D-122, D-125, D-127,
D-130 to D-132, D-136, D-146, D-148,
D-151 to D-153, D-155 to D-160,
D-165 to D-167, D-169, F-35,
F-38 to F-40, F-42, F-53 to F-54,
F-56 to F-57, F-60, F-62 to F-63,
F-68 to F-70, G-197, G-205, G-264
- polychlorinated biphenyl (PCB)
B-69, B-97, B-128, G-24, G-29
- potential release site(s) (PRS)
G-34
- prehistoric
E-1, E-3 to E-6, E-11, E-20,
E-25 to E-27, E-29 to E-31,
E-38 to E-39, E-43, E-47, E-52,
E-55 to E-56, G-87, G-122
- Programmatic Environmental Impact Statement
for Stockpile Stewardship and Management
(SSM PEIS)
G-50
- project-specific siting and construction (PSSC)
F-43
- public health
D-1, D-10 to D-12, D-28 to D-30, D-32,
D-42, D-170, G-269
- Pueblo Canyon
B-74, C-120, C-149 to C-150,
E-45 to E-46, G-107 to G-108,
G-110 to G-111
- Pueblo(s)
A-4, A-15 to A-16, B-19 to B-20,
B-72 to B-74, C-32 to C-34,
C-58 to C-59, C-97 to C-99,
C-101 to C-104, C-120, C-131 to C-132,
C-142 to C-143, C-149 to C-150,
C-160 to C-161, D-16, D-46, E-3 to E-4,
E-6 to E-9, E-12 to E-21, E-25,
E-28 to E-29, E-31, E-38 to E-46,
E-48 to E-52, E-54, E-56, G-14, G-155,
G-161, G-168, G-171 to G-172, G-176,
G-186, G-195, G-204, G-210, G-221,
G-233, G-244, G-253
- R**
- Radioactive Liquid Waste Treatment Facility
(RLWTF)
A-2, A-5, D-46, G-24, G-29, G-90, G-93,
G-95 to G-96, G-108, G-274
- Radioactive Materials Research, Operations,
and Demonstration (facility) (RAMROD)
G-24, G-29, G-61, G-63, G-67 to G-68,

G-78, G-84, G-90, G-93, G-95 to G-96,
G-98, G-175, G-177, G-179, G-197,
G-275

radiological exposure

F-31, G-39, G-106, G-111, G-124

radiological impact

G-171

radionuclide

B-3 to B-5, B-8 to B-9, B-11 to B-17,
B-28, C-1 to C-2, C-130, C-163, D-2,
D-6, D-11, D-28 to D-29, D-31, D-35,
D-40, D-45, D-47 to D-48,
D-138 to D-139, D-171, D-173,
G-12 to G-13, G-23, G-60, G-101,
G-109, G-124, G-166, G-184,
G-196 to G-197, G-219, G-274

RADTRAN

F-20 to F-21, F-25 to F-26, F-30, F-47,
F-53, F-55, F-70, F-74, F-77, G-132

Record of Decision (ROD)

G-50, G-167

Reduced Operations

A-2, A-12 to A-13, D-35, D-39 to D-43,
F-1, F-44 to F-48, F-50 to F-51, F-57,
F-59, F-61 to F-66, F-69, F-71, G-5,
G-81, G-116, G-119, G-124,
G-126 to G-127, G-134, G-138, G-141,
G-145, G-147, G-152, G-155, G-157,
G-161, G-165, G-168, G-170,
G-174 to G-176, G-181, G-183, G-186,
G-195, G-199, G-203, G-210 to G-213,
G-215, G-217, G-221, G-226, G-233,
G-236, G-243 to G-245, G-250, G-252,
G-255 to G-258, G-261 to G-263,
G-266 to G-267

Rendija Canyon

C-150 to C-151, G-87

reservoir

B-73, D-32, D-45, E-4, E-19,
E-47 to E-48, E-55

Resource Conservation and Recovery Act
(RCRA)

F-43, F-72, G-110, G-151 to G-152,

G-179 to G-181, G-272

road closure(s)

F-21, F-23, F-40 to F-42, G-167

Royal Crest

B-73, G-96, G-98, G-100, G-117, G-119,
G-147, G-155, G-161, G-186, G-206,
G-210, G-233, G-244, G-253, G-261

S

safe secure transport (SST)

F-15, F-21, F-23, F-25, F-33 to F-37,
F-39, F-45, F-53 to F-54

Safety Analysis Report (SAR)

F-75, G-6, G-30, G-34, G-38, G-71,
G-89 to G-91, G-111, G-116, G-118,
G-128, G-143, G-147 to G-148, G-154,
G-156 to G-158, G-160 to G-161, G-163,
G-165 to G-168, G-176 to G-177,
G-181 to G-182, G-184, G-188 to G-189,
G-194 to G-198, G-200, G-204, G-206,
G-208, G-216, G-218 to G-219, G-221,
G-227, G-244, G-253, G-258, G-261,
G-269 to G-270, G-274 to G-276, G-278

San Ildefonso

A-11, A-15 to A-16, B-19 to B-20, B-73,
C-82 to C-84, D-16, D-46, D-58 to D-60,
D-101, D-120, D-131, D-138 to D-139,
D-141, D-144, D-158, D-166, E-7 to E-8,
E-12 to E-13, E-16, E-28, E-38, E-40,
E-43, E-46, E-49, G-155, G-161, G-168,
G-172, G-176, G-186, G-195, G-204,
G-210, G-221, G-233, G-244, G-253

Sandia Canyon

A-5, C-120 to C-121, C-151 to C-153
Santa Fe A-11, A-13 to A-15, A-17, B-52,
B-73, B-75, B-259, D-16, D-116, D-136,
D-145, D-169 to D-170, E-8, E-10, E-13,
E-16, E-38, E-42 to E-45, E-47 to E-50,
E-52 to E-56, F-23, F-25 to F-26, F-47,
F-64 to F-72, F-76, F-78, G-39, G-56,
G-103, G-105, G-123 to G-124,
G-171 to G-172, G-212, G-268, G-272

- secondary(ies)
 B-38, D-16, E-2, E-9, F-12, F-36, G-175,
 G-180, G-188, G-193
- seismic
 G-12, G-18, G-27 to G-29, G-31, G-36,
 G-38, G-42, G-44, G-46, G-49, G-55,
 G-59, G-68 to G-69, G-82, G-85,
 G-87 to G-90, G-93 to G-95, G-97,
 G-99 to G-100, G-212 to G-213, G-269,
 G-273, G-277 to G-278, G-280
- sigma
 D-47
- special nuclear material (SNM)
 F-15, F-33, F-40 to F-41, F-72, G-14,
 G-24 to G-25
- S-Site
 D-144
- stabilization
 F-35
- State Historic Preservation Office(r) (SHPO)
 E-2, E-21 to E-22, E-24 to E-25, E-36,
 E-38 to E-39
- State of New Mexico
 A-18, B-16, B-38 to B-40, B-53, E-13,
 E-26, F-21 to F-22
- stockpile stewardship and management (SSM)
 F-76, G-14, G-271
- Stockpile Stewardship and Management
 Programmatic Environmental Impact Statement
 (SSM PEIS)
 H-1
- stockpile surveillance
 G-255
- Strategic Arms Reduction Talks (START)
 E-11
- T**
-
- targets
 A-4 to A-5, D-2, D-9, D-34,
 D-36 to D-37, F-20, F-28, F-36, F-38,
 F-42, F-53 to F-55, F-60, F-62, F-72,
 F-78, G-174, G-189
- Technical Area (TA)-50
 B-2 to B-3, B-49, B-56 to B-58, B-60,
 B-62, B-153, B-157, D-46, F-41,
 G-24 to G-25, G-29, G-34 to G-35,
 G-40 to G-43, G-46, G-61, G-63,
 G-65 to G-67, G-72 to G-74, G-90, G-93,
 G-95 to G-96, G-98 to G-99, G-108,
 G-120, G-175, G-181 to G-182, G-185,
 G-194
- Technical Area (TA)-54
 B-2, B-4, B-13, B-17 to B-20,
 B-22 to B-28, B-49, B-51, B-60, B-153,
 B-158, D-136, D-139, D-145,
 F-39 to F-43, G-13, G-24 to G-25,
 G-28 to G-29, G-34 to G-36,
 G-41 to G-42, G-45 to G-46, G-61,
 G-63 to G-68, G-70, G-72 to G-73,
 G-90 to G-91, G-93, G-95 to G-96, G-99,
 G-114, G-117 to G-120, G-123, G-125,
 G-131 to G-132, G-139 to G-144, G-146,
 G-151 to G-152, G-177, G-182, G-185,
 G-187 to G-188, G-192, G-194 to G-196,
 G-198, G-204
- Technical Area (TA)-55
 B-2, B-4 to B-5, B-11, B-17 to B-20,
 B-22 to B-27, B-46, B-49, B-56,
 B-59 to B-60, B-62, B-144,
 B-155 to B-156, B-158, B-185,
 B-245 to B-249, D-34, D-106,
 F-35 to F-36, F-38 to F-43, F-54, F-60,
 G-15, G-24 to G-25, G-27 to G-29,
 G-33 to G-36, G-40 to G-41, G-45,
 G-49 to G-51, G-54 to G-55, G-61, G-63,
 G-65 to G-67, G-70, G-72 to G-74, G-83,
 G-87 to G-88, G-91, G-93,
 G-97 to G-101, G-114, G-128,
 G-146 to G-148, G-158, G-194,
 G-205 to G-206, G-208, G-220, G-222,
 G-224 to G-227, G-232, G-234 to G-235,
 G-239, G-258, G-261, G-263 to G-265
- threatened and endangered (T&E) species
 G-122

Totavi

D-54 to D-55

traditional cultural property (TCP)

E-1, E-3 to E-4, E-11 to E-12, E-14,
E-16, E-20, E-22 to E-25, E-27 to E-31,
E-34, E-38, E-40, E-42 to E-44, E-46

transportation corridor

E-3

transuranic (TRU) waste

F-5, F-8, F-12, F-41, F-63, F-78, G-25,
G-29, G-40 to G-41, G-45, G-64,
G-67 to G-68, G-77 to G-79,
G-83 to G-85, G-90 to G-91, G-93, G-99,
G-107, G-109 to G-110, G-124, G-131,
G-145, G-151 to G-153, G-177 to G-180,
G-182 to G-185, G-187 to G-191,
G-193 to G-194, G-196 to G-201, G-271,
G-274 to G-275, G-278 to G-279

transuranic (waste) (TRU) characterization

G-183

Transuranic Waste Inspectable Storage Project (TWISP)

G-24, G-28 to G-29, G-41, G-61, G-63,
G-65 to G-68, G-72 to G-74, G-78, G-84,
G-95, G-185, G-187 to G-190, G-193,
G-195 to G-196, G-198, G-200, G-204

tritium

A-2, A-4 to A-5, B-2, B-6, B-8 to B-9,
B-11, B-13, B-16, B-18 to B-19,
B-22 to B-27, B-29, C-3 to C-7, C-10,
C-13, C-15, C-17, C-19, C-21, C-23,
C-25, C-27, C-29, C-32, C-34, C-36,
C-38, C-40 to C-41, C-43, C-45 to C-47,
C-49 to C-50, C-52 to C-53,
C-55 to C-57, C-59, C-61 to C-62, C-67,
C-70, C-72, C-75, C-77, C-80, C-82,
C-84, D-7, D-33, D-35, D-45 to D-46,
D-50, D-54, D-58, D-61, D-65, D-69,
D-72, D-75, D-79 to D-80, D-83 to D-84,
D-87, D-91 to D-92, D-96 to D-97,
D-101 to D-107, D-111 to D-113,
D-120 to D-122, D-125, D-131 to D-132,
D-136, D-140, D-146, D-148,
D-150 to D-153, D-155 to D-157, D-159,
D-166 to D-167, D-169, F-5, F-8,F-33 to F-34, F-36, F-38, F-43, G-1, G-9,
G-15, G-27 to G-29, G-31, G-40 to G-41,
G-45, G-59, G-68 to G-69, G-72 to G-75,
G-78, G-84, G-89, G-95, G-98 to G-99,
G-116 to G-117, G-119, G-123, G-125,
G-174 to G-176, G-274 to G-275

Tritium System Test Assembly (TSTA)

A-2, A-5, B-4, B-20, D-41, G-15, G-29,
G-47, G-61, G-63, G-67 to G-68, G-84,
G-90, G-93, G-95, G-116, G-119, G-123,
G-124, G-158, G-174 to G-176U

U.S. Department of Defense (DoD)

E-2, E-11, E-49, F-15, G-106, G-251

U.S. Department of Energy (DOE)

F-75 to F-76

U.S. Department of Transportation (DOT)

F-1 to F-3, F-5 to F-6, F-8, F-15, F-21,
F-23, F-26, F-75 to F-76, G-37, G-130,
G-133, G-139, G-141, G-147, G-151,
G-177, G-180, G-196 to G-197, G-272

U.S. Environmental Protection Agency (EPA)

A-2, B-4, B-38 to B-40, B-42, B-47,
B-75, B-143, B-145, B-158, B-160,
B-182 to B-183, B-185, B-189, B-191,
B-203 to B-207, B-210 to B-212, B-215,
B-220, B-230, B-236, B-238 to B-239,
B-243, B-245, B-247, B-251, B-255,
B-259 to B-260, C-130, C-163, D-1, D-8,
D-10 to D-11, D-28 to D-29,
D-31 to D-32, D-40, D-42 to D-46, D-53,
D-57, D-64, D-68, D-71, D-74, D-78,
D-86, D-90, D-95, D-102 to D-106,
D-108, D-110 to D-111, D-115, D-117,
D-119 to D-120, D-124 to D-125, D-127,
D-129, D-131 to D-135, D-138,
D-141 to D-142, D-171, G-11, G-33,
G-37, G-75, G-97, G-128, G-138, G-143,
G-148, G-214, G-272, G-277

U.S. Fish and Wildlife Service (FWS)

E-4

U.S. Nuclear Regulatory Commission (NRC)

D-8, F-1, F-3, F-8, F-12, F-26,
F-28 to F-29, F-77, G-44, G-55, G-109,
G-223, G-269, G-273, G-277 to G-279

uranium

B-7 to B-9, B-12 to B-13, B-16,
B-27 to B-28, B-46 to B-47, B-69, B-95,
B-229, B-231, C-10, C-13, C-15, C-17,
C-19, C-21, C-23, C-25, C-27, C-29,
C-32, C-34, C-36, C-38, C-40,
C-42 to C-43, C-45 to C-46,
C-48 to C-50, C-52 to C-53,
C-55 to C-57, C-59, C-61 to C-62, C-67,
C-70, C-72, C-75, C-77, C-80, C-82,
C-84, C-87, C-90, C-94, C-96, C-99,
C-101, C-103, C-132, C-134,
C-137 to C-139, C-141 to C-143, C-145,
C-147, C-149, C-153, C-156, C-158,
C-160 to C-161, C-163, D-3, D-6 to D-7,
D-42, D-48, D-50, D-54, D-58, D-61,
D-65, D-75 to D-76, D-79 to D-80,
D-83 to D-84, D-87 to D-88,
D-91 to D-92, D-96 to D-97,
D-102 to D-108, D-111 to D-113,
D-120 to D-122, D-125 to D-127,
D-130 to D-132, D-136, D-139 to D-140,
D-146, D-148, D-151 to D-153,
D-155 to D-160, D-165 to D-167, D-169,
F-5, F-33, F-35, F-37 to F-38,
F-41 to F-42, G-9, G-15, G-24,
G-26 to G-28, G-31, G-40, G-45, G-75,
G-78, G-84, G-91, G-107 to G-110,
G-124, G-163, G-166, G-216,
G-258 to G-260, G-277, G-279

V

vault

F-15, G-24, G-27, G-45, G-61, G-67,
G-89, G-95, G-100, G-116, G-158,
G-175, G-205 to G-206, G-213, G-263,
G-274, G-278

volatile organic compound (VOC)

B-46, B-204, B-215 to B-216, B-224

W

Waste Isolation Pilot Plant (WIPP)

F-8, F-75, F-79, G-152 to G-153, G-184,
G-187, G-193 to G-194, G-196 to G-197,
G-199, G-271

waste management

B-13, B-27, B-38, G-34, G-120, G-183,
G-185, G-194, G-197 to G-199,
G-275 to G-276

waste minimization

G-5

wastewater

A-11, F-8, G-24 to G-26

Weapons Engineering Tritium Facility (WETF)

B-4, B-20, D-41, G-15, G-24, G-29,
G-61, G-67, G-89, G-98 to G-99, G-116,
G-119, G-123 to G-125, G-158, G-274

wetland

G-122

White Rock

A-15, B-19 to B-20, B-22 to B-26, B-74,
D-27, D-101, D-111, D-114, D-123,
D-144, E-2, E-7, E-43 to E-44, E-46,
G-78, G-96, G-117, G-119 to G-120,
G-124, G-171 to G-172, G-195, G-204,
G-212

wildfire

G-18, G-39, G-44, G-46, G-50, G-76,
G-82, G-87, G-100, G-103,
G-107 to G-108, G-111 to G-113,
G-115 to G-118, G-120 to G-125, G-151,
G-181, G-277, G-280

worker dose

D-33 to D-35, G-160

APPENDIX A

WATER RESOURCES

A.1 SURFACE WATER NATIONAL POLLUTANT DISCHARGE ELIMINATION SYSTEM VOLUMES

One of the primary sources of potential impacts to surface water at the Los Alamos National Laboratory (LANL) is the National Pollutant Discharge Elimination System (NPDES) outfalls. NPDES outfall flow projections were prepared by alternative. Table A.1-1 identifies each industrial outfall by facility, outfall number, and watershed. The index discharge as of August 1996 is also presented along with outfall projections for each alternative.

A.2 GROUNDWATER HYDRAULIC PROPERTIES

The nature and extent of groundwater bodies in the LANL region has not been fully characterized. To better understand the hydrogeologic characterization of Pajarito Plateau, LANL personnel have prepared a Hydrogeologic Workplan (LANL 1998). The workplan proposes the installation of new wells that will further investigate the recharge and cross-connection mechanisms to the main aquifer (section 4.3.2.3). Current data indicate that groundwater bodies occur near the surface of the earth in canyon bottoms, alluvium, perched at deeper levels (intermediate perched groundwater), and at deeper levels in the main aquifer. Table A.2-1 presents summary information on the hydraulic parameters of groundwater bodies in the LANL region.

A.3 MAIN AQUIFER VOLUME ESTIMATES

The main aquifer is the only groundwater body within the LANL region that is sufficiently

saturated and permeable to transmit economic quantities of water to wells for public use. Recharge of the main aquifer is not fully understood nor characterized. Recent investigations suggest that the majority of water pumped to date from the main aquifer has been from storage, with minimal recharge (Rogers et al. 1996). Because this groundwater body is the only source of potable water within the region, the amount of water available for future use is of interest to many.

For the purposes of the Site-Wide Environmental Impact Statement (SWEIS), water storage calculations were made using a model developed by the United States (U.S.) Geological Survey (USGS). For modeling regional flow in the main aquifer, USGS subdivided the main aquifer into eight layers, which have a total thickness of 5,600 feet (1,707 meters) (Figure A.3-1). The model grid uses 25 columns and 33 rows spaced at 1-mile intervals. The volume of water stored in any given cell is equal to the storage coefficient multiplied by the volume of the cell. For all cells, a value of 0.1554 was used for the storage coefficient, which was based on a specific yield value of 0.15 and specific storage capacity of 1×10^{-6} per foot. The volume of water stored beneath any given region is the sum of water stored in the cells, bounded by the region, and extending to the total depth of the aquifer.

The volume for the main aquifer beneath the Española Basin is underestimated by this model, as the basin actually extends beyond the modeled region (Figure A.3-2). Table A.3-1 presents a summary of the values used to calculate the amount of water stored in the main aquifer beneath the Pajarito Plateau (which is a subset of the total area that USGS modeled), the area from which the Department of Energy (DOE) water is drawn. Table A.3-2 presents a

TABLE A.1-1.—Volume of NPDES by Watershed for Index and Alternatives^a

FACILITY ^f	OUTFALL	LEGEND ^g	TA ^e	BLDG.	DESCRIPTION ^h	WATERSHED	DISCHARGES ^b (MILLIONS OF GALLONS PER YEAR)			
							INDEX (08/96)	NO ACTION	EXPANDED OPERATIONS	REDUCED OPERATIONS
KEY FACILITIES										
HE Testing	04A-141	85	39	69	Light Gas Gun Fac.	Ancho	0.03			
HE Testing	04A-156	86	39	89	Gas Gun Shop	Ancho	0.09			
HRL	03A-040	08	43	01	HRL	Los Alamos	2.70	2.50	2.50	2.50
LANSCE	03A-047	18	53	60	Linac C-Tower	Los Alamos	2.64	4.70	7.10	2.30
LANSCE	03A-048	19	53	62	Linac C-Tower	Los Alamos	8.56	15.60	23.40	7.70
LANSCE	03A-049	20	53	64	Linac C-Tower	Los Alamos	4.15	7.50	11.30	3.70
Tritium	02A-129	11	21	155N,357	Steam Plant	Los Alamos	0.11	0.11	0.11	0.11
Tritium	03A-036	12	21	152,155, 155N, 220	Lab., TSTA, C-Tower	Los Alamos	0.02			
Tritium	03A-158	14	21	209	TSFF	Los Alamos	0.22	0.22	0.22	0.11
Tritium	05S(STP)	15	21	227	Sewage treatment	Los Alamos	0.77			
CMR	03A-021	31	03	29	CMR	Mortandad	0.53	0.53	0.53	0.53
Plutonium	03A-181	38	55	06	Utility Bldg.	Mortandad	14.00	14.00	14.00	14.00
Radiochemistry	03A-045	37	48	01	RC-1	Mortandad	1.10	0.87	0.87	0.87
Radiochemistry	04A-016	34	48	01	RC-1	Mortandad	6.30			
Radiochemistry	04A-131	33	48	01	RC-1	Mortandad	0.95			
Radiochemistry	04A-152	36	48	28	RC-1	Mortandad	4.00			
Radiochemistry	04A-153	35	48	01	RC-1	Mortandad	3.20	3.20	3.20	3.20
RLWTF	EPA051	39	50	01	RLWTF	Mortandad	5.51	6.60	9.30	5.30
Sigma	03A-022	32	03	66,127,141	Sigma Complex	Mortandad	4.40	4.40	4.40	4.40
TFF	04A-127	40	35	213	TFF	Mortandad	2.00			
HE Processing	04A-115	49	08	70	NDT Facility	Pajarito	0.53			
HE Processing	05A-066	53	09	A,21,28	Lab. Shop	Pajarito	4.36	0.74	0.74	0.74
HE Processing	05A-067	51	09	B,41,42	Laboratory	Pajarito	0.33	0.33	0.33	0.33
HE Processing	05A-068	52	09	48	Machining Bldg.	Pajarito	1.16	0.06	0.06	0.06
HE Processing	06A-074	48	08	22	X-ray Bldg.	Pajarito	0.25			
HE Processing	06A-075	50	08	21	Laboratory	Pajarito	1.00			
HE Testing	04A-101	58	40	09	Firing Site	Pajarito	0.05			
HE Testing	04A-143	61	15	306	Hydrotest Bldg.	Pajarito	0.02	0.02	0.02	0.02

TABLE A.1-1.—Volume of NPDES by Watershed for Index and Alternatives^a-Continued

FACILITY ^f	OUTFALL	LEGEND ^g	TA ^e	BLDG.	DESCRIPTION ^h	WATERSHED	DISCHARGES ^b (MILLIONS OF GALLONS PER YEAR)				GREENER
							INDEX (08/96)	NO ACTION	EXPANDED OPERATIONS	REDUCED OPERATIONS	
HE Testing	06A-079	54	40	04	Firing Site	Pajarito	0.54	0.54	0.54	0.54	0.54
HE Testing	06A-080	55	40	05	Firing Site	Pajarito	0.03	0.03	0.03	0.03	0.03
HE Testing	06A-081	56	40	08	Firing Site	Pajarito	0.03	0.03	0.03	0.03	0.03
HE Testing	06A-082	59	40	12	Preparation Room	Pajarito	0.03				
HE Testing	06A-099	57	40	23	Laboratory	Pajarito	0.03				
HE Testing	06A-100	60	40	15	Firing Site	Pajarito	0.04	0.04	0.04	0.04	0.04
LANSCE	03A-113	21	53	293,294,1032	LEDA C-Towers	Sandia	0.90	39.70	39.80	12.30	39.80
LANSCE	03A-125	23	53	28	Proton Storage Ring	Sandia	0.18	0.18	0.18	0.18	0.18
LANSCE	03A-145	22	53	06	Orange Box Offices	Sandia	0.37				
Sigma	03A-024	30	03	35,187	Press Bldg./ C. Tower	Sandia	2.90	2.90	2.90	2.90	2.90
HE Processing	02A-007	64	16	540	Steam Plant	Water	10.50	7.40	7.40	7.40	7.40
HE Processing	03A-130	81	11	30	Laboratory	Water	0.04	0.04	0.04	0.04	0.04
HE Processing	04A-070	65	16	220	X-ray Bldg.	Water	0.22				
HE Processing	04A-083	73	16	202	Shops	Water	0.20				
HE Processing	04A-092	80	16	370	Metal Forming	Water	1.57				
HE Processing	04A-157	75	16	460	Laboratory	Water	7.31				
HE Processing	05A-053	79	16	410	Assembly Bldg.	Water	0.12				
HE Processing	05A-054	68	16	340	HE Synthesis	Water	3.57	3.60	3.60	3.60	3.60
HE Processing	05A-055	78	16	401,406	Pressure Tanks	Water	0.04	0.13	0.17	0.10	0.10
HE Processing	05A-056	67	16	260	Process Bldg.	Water	2.53				
HE Processing	05A-069	82	11	50	Drop Tower Sump	Water	0.00	0.00	0.00	0.00	0.00
HE Processing	05A-071	77	16	430	HE Pressing	Water	0.04	0.04	0.04	0.04	0.04
HE Processing	05A-072	74	16	460	Laboratory	Water	0.02				
HE Processing	05A-096	83	11	51	Drop Tower Sump	Water	0.00	0.00	0.00	0.00	0.00
HE Processing	05A-097	84	11	52	Drop Tower Sump	Water	0.00	0.00	0.00	0.00	0.00
HE Processing	06A-073	66	16	222	Dark Room	Water	0.08				
HE Testing	03A-028	72	15	184,185,202	Cooling Tower	Water	2.20	2.20	2.20	2.20	2.20
HE Testing	03A-185	70	15	184,202	Cooling Tower	Water	0.73	0.73	0.73	0.73	0.73
HE Testing	04A-139	71	15	184	PHERMEX	Water	0.00				
HE Testing	06A-123	69	15	183	Laboratory	Water	0.13				

TABLE A.1-1.—Volume of NPDES by Watershed for Index and Alternatives^a-Continued

FACILITY ^f	OUTFALL	LEGEND ^g	TA ^e	BLDG.	DESCRIPTION ^h	WATERSHED	DISCHARGES ^b (MILLIONS OF GALLONS PER YEAR)							
							INDEX (08/96)	NO ACTION	EXPANDED OPERATIONS	REDUCED OPERATIONS	GREENER			
Tritium	04A-091	76	16	450	Process Bldg.	Water	0.22							
	Sum, Key Facilities				59 Outfalls ^d		104	119	136	76				133
NON-KEY FACILITIES														
S&T	03A-042	44	46	01	Laboratory	Cañada del Buey	5.30	5.30	5.30	5.30	5.30	5.30	5.30	5.30
S&T	04A-118	46	54	1013	Pajarito #4 Well	Cañada del Buey	1.10	1.10	1.10	1.10	1.10	1.10	1.10	1.10
S&T	04A-166	43	05	26	Pajarito #5 Well	Cañada del Buey	0.01	0.01	0.01	0.01	0.01	0.01	0.01	0.01
S&T	03A-038	87	33	114	Support Bldg.	Chaquehui	5.80							
S&T	04A-171	07	NF	01	Guaje #1 Well	Guaje	0.00	0.00	0.00	0.00	0.00	0.00	0.00	0.00
S&T	04A-172	06	NF	01A	Guaje #1A Well	Guaje	0.00	0.00	0.00	0.00	0.00	0.00	0.00	0.00
S&T	04A-173	05	NF	02	Guaje #2 Well	Guaje	0.00	0.00	0.00	0.00	0.00	0.00	0.00	0.00
S&T	04A-174	04	NF	04	Guaje #4 Well	Guaje	0.00	0.00	0.00	0.00	0.00	0.00	0.00	0.00
S&T	04A-175	02	NF	05	Guaje #5 Well	Guaje	0.00	0.00	0.00	0.00	0.00	0.00	0.00	0.00
S&T	04A-176	01	NF	06	Guaje #6 Well	Guaje	0.66	0.66	0.66	0.66	0.66	0.66	0.66	0.66
S&T	04A-177	03	NF	B1	Guaje Booster #1 Well	Guaje	0.06	0.06	0.06	0.06	0.06	0.06	0.06	0.06
S&T	03A-034	13	21	166	Equipment Bldg.	Los Alamos	0.26							
S&T	03A-035	10	21	210	Research Bldg.	Los Alamos	0.04							
S&T	04A-182	09	21	1003	Backflow Preventer	Los Alamos	0.00	0.00	0.00	0.00	0.00	0.00	0.00	0.00
S&T	04A-186	16	21	452	Otowi #4 Well	Los Alamos	0.18	0.18	0.18	0.18	0.18	0.18	0.18	0.18
S&T	03A-160	41	35	124	Antares Target Hall	Mortandad	5.10	5.10	5.10	5.10	5.10	5.10	5.10	5.10
S&T	06A-132	42	35	87	Laboratory	Mortandad	5.80							
S&T	03A-025	47	03	208	Equipment Bldg.	Pajarito	0.18	0.18	0.18	0.18	0.18	0.18	0.18	0.18
S&T	04A-164	63	18	252	Pajarito #2 Well	Pajarito	0.01	0.01	0.01	0.01	0.01	0.01	0.01	0.01
S&T	06A-106	62	36	01	Laboratory	Pajarito	0.58	0.58	0.58	0.58	0.58	0.58	0.58	0.58
S&T	04A-161	17	72	01	Otowi #1 Well	Pueblo	1.00	1.00	1.00	1.00	1.00	1.00	1.00	1.00
S&T	01A-001 ^c	27	03	22	Power Plant	Sandia	77.9	113.90	113.90	113.90	113.90	113.90	113.90	113.90
S&T	03A-027	28	03	285	Cooling Tower	Sandia	5.80	5.80	5.80	5.80	5.80	5.80	5.80	5.80
S&T	03A-148	26	03	1498	Data Center	Sandia	6.30							
S&T	04A-094	29	03	170	Gas Facility	Sandia	5.30							
S&T	04A-163	25	72	04	Pajarito #1 Well	Sandia	6.20	6.20	6.20	6.20	6.20	6.20	6.20	6.20
S&T	04A-165	24	72	07	Pajarito #3 Well	Sandia	2.00	2.00	2.00	2.00	2.00	2.00	2.00	2.00

TABLE A.1-1.—Volume of NPDES by Watershed for Index and Alternatives^a-Continued

FACILITY ^f	OUTFALL	LEGEND ^g	TA ^e	BLDG.	DESCRIPTION ^h	WATERSHED	DISCHARGES ^b (MILLIONS OF GALLONS PER YEAR)			
							INDEX (08/96)	NO ACTION	EXPANDED OPERATIONS	REDUCED OPERATIONS
	Sum, Non-Key Facilities				28 Outfalls ^{c,d}		261	142	142	142
	LANL Total						261	278	218	275

^a NPDES Information Sources: Index information was provided by the Surface Water Data Team Reports of August 1996 (Bradford 1996) and as modified in 1997 (Garvey 1997). Outfall flow projections for the alternatives were based on the outfalls remaining as of November 1997.

^b When no discharge is indicated under the alternative, this means the outfall was eliminated. For outfalls with 0.00 flow, this means the outfall still remains but the projected flow is so small that it was rounded down to zero.

^c All effluent from the TA-46 Sewage Treatment Facility Sanitary Waste System Consolidation (SWSC) is pumped to a re-use tank adjacent to the TA-3 power plant. When the power plant is in operation, water is drawn from the tank as make-up for the power plant cooling towers where it is either lost to the air through evaporation or discharged to Sandia Canyon via the power plant Outfall 01A-001. For the index flow, of the total 77.9 MGY flow for Outfall 01A-001, approximately 29.0 MGY is contributed by SWSC as make-up water. For the other four alternatives, of the total 113.9 million gallons per year (MGY) flow for Outfall 01A-001, approximately 65 MGY is contributed by SWSC as make-up water. Outfall 135 is located at the TA-46 SWSC facility but is not used. Outfall 135, although not listed in the table, is added to the number of outfalls, making a total of 28 outfalls for the non-key facilities.

^d Number of outfalls identified, 59 and 28, for key and non-key, respectively, are for the index outfalls. The number of outfalls for all the alternatives is 33 and 28 for key and non-key, respectively. This reduction in outfalls from the index for key facilities is due to LANL's ongoing Outfall Reduction Program. Outfall flow projections for the alternatives were based on the outfalls remaining as of November 1997.

^e NF = National Forest

^f HE = High explosives, HRC = Health Research Laboratory, LANSCE = Los Alamos Neutron Science Center, CMR = Chemistry and Metallurgy Research, RLWTF = Radioactive Liquid Waste Treatment Facility, TFF = Target Fabrication Facility, S&T = Science and Technology

^g Legend numbers correspond to NPDES locations shown in Figure 4.3.1.3-1

^h TSTA = Tritium System Test Assembly, TSFF = Tritium Science and Fabrication Facility, NDT = Nondestructive Testing, LEDA = Low-Energy Demonstration Accelerator, PHERMEX = Pulsed High-Energy Radiation Emitting X-Ray Facility

TABLE A.2-1.—Hydraulic Characteristics of Groundwater Bodies, LANL Region

	POROSITY (%)	HYDRAULIC CONDUCTIVITY (cm/sec)
Alluvium^a (may contain alluvial groundwater)	43	4.00E-04
Tuff^a (may contain intermediate perched groundwater)	48	2.00E-04
Main Aquifer Formations^{b,c}		
Puye Formation		4.60E-04
Tesuque Formation		3.00E-04
Tschicoma Formation		9.00E-04

^a Data from Rogers and Gallaher 1995.

^b Data from Purtymun 1984. Hydraulic conductivity converted from gallons per day per square foot, cm/sec is centimeters per second.

^c Porosity values for the main aquifer formations are not readily available from the published literature.

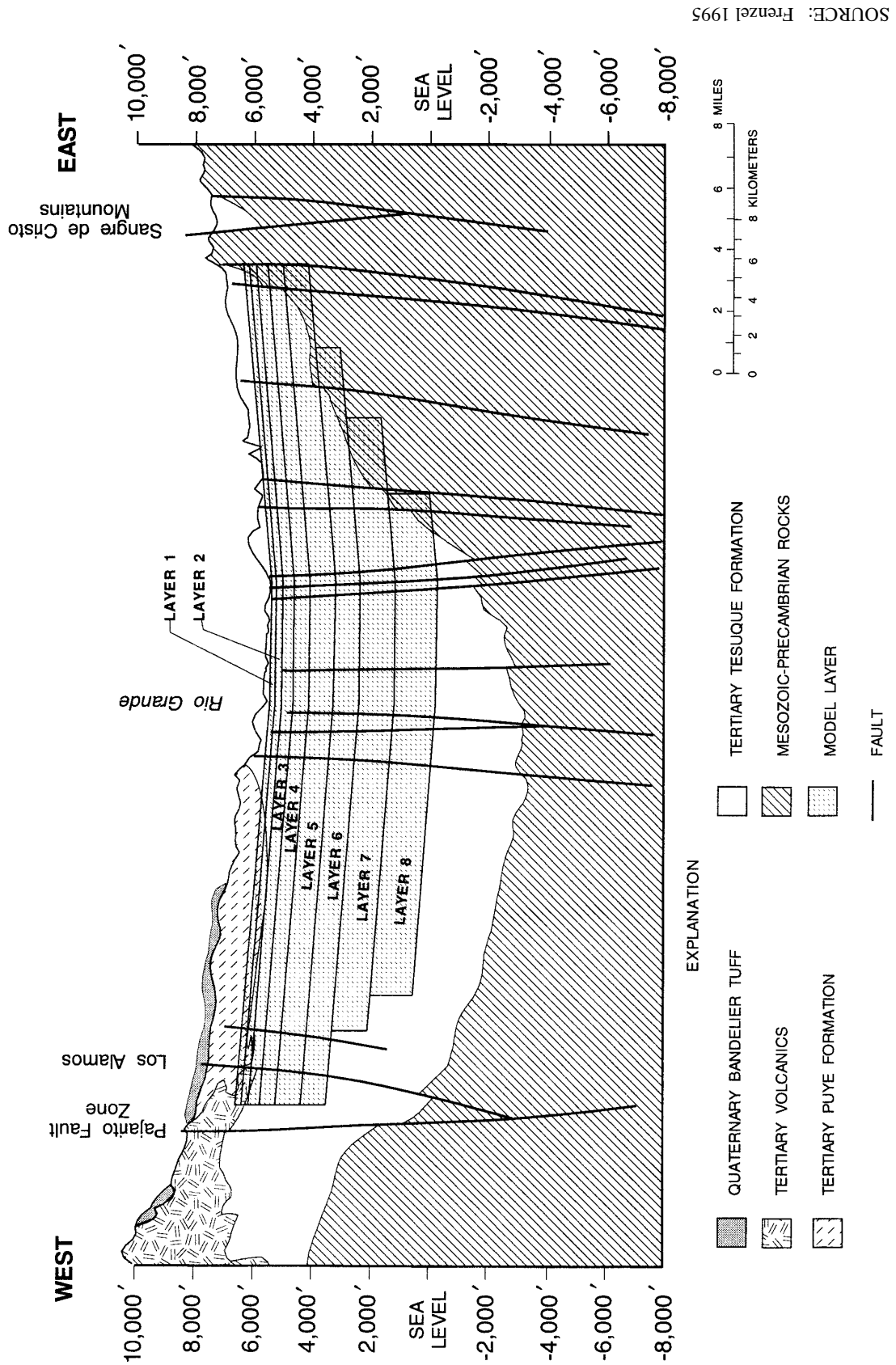

FIGURE A.3-1.—Diagrammatic Section of Model Layers and Subsurface Geology.

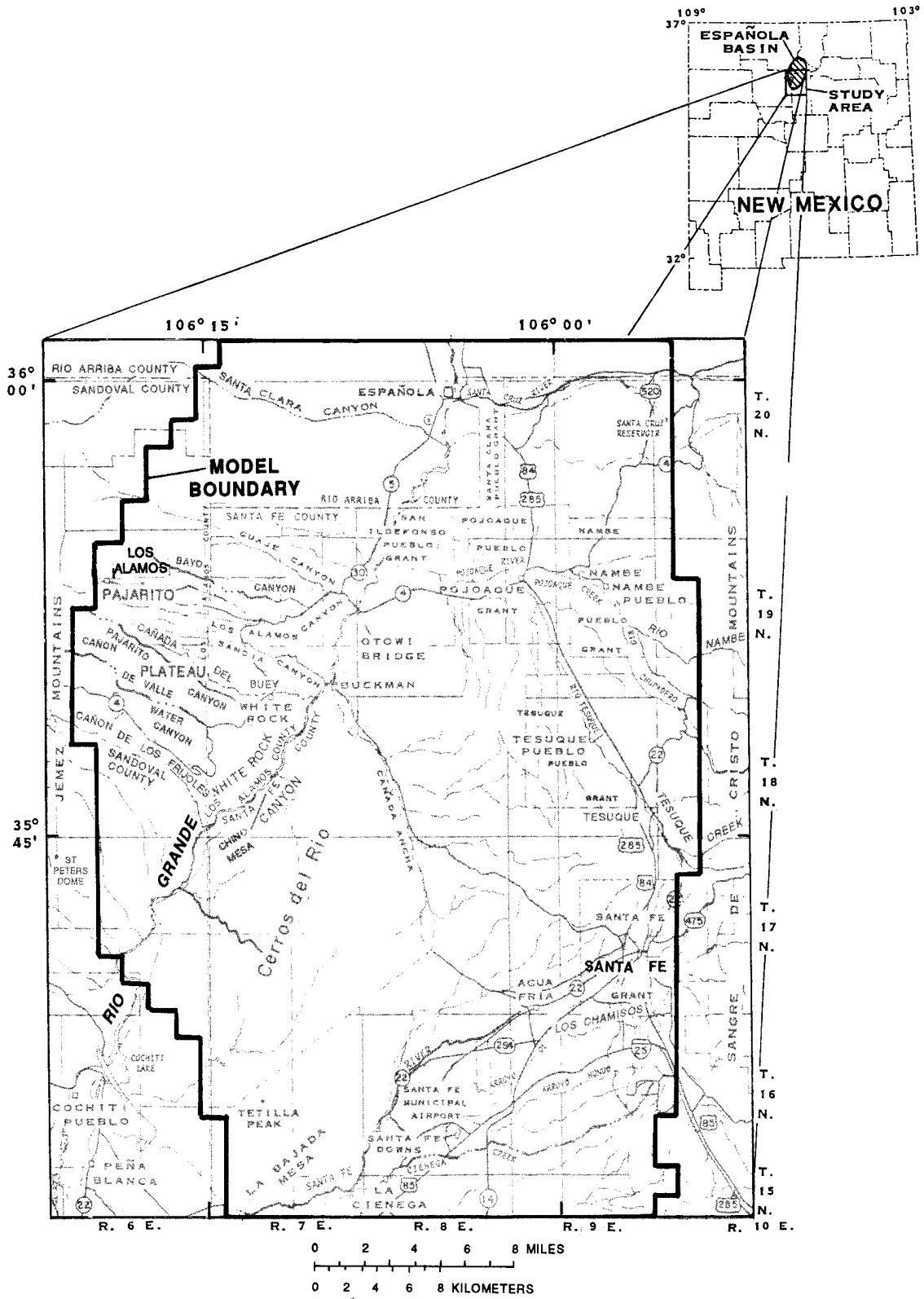

FIGURE A.3-2.—Area USGS Modeled.

SOURCE: Frenzel 1995

TABLE A.3-1.—Estimated Water Storage of Main Aquifer Beneath Pajarito Plateau

MODEL LAYER NO.	(A) LAYER THICKNESS (FEET)	(B) NUMBER OF ACTIVE CELLS IN REGION	(C) VOLUME OF AQUIFER IN THE LAYER (CUBIC FEET)	(D) STORAGE COEFFICIENT OF WATER PER CUBIC FEET OF AQUIFER	(E) VOLUME OF WATER WITHIN LAYER (CUBIC FEET)	(F) CUMULATIVE AQUIFER THICKNESS (FEET)	(G) CUMULATIVE WATER VOLUME (CUBIC FEET)	(H) CUMULATIVE WATER VOLUME (GALLONS)	(I) CUMULATIVE YEARS TO DEplete AT DOE WATER RIGHTS RATE (SEE TABLE A.3-3)
1	200	124	6.91384E+11	0.1554	1.07441E+11	200	1.07441E+11	8.0376710 ⁺¹¹	445
2	275	124	9.50653E+11	0.1554	1.47732E+11	475	2.55173E+11	1.9089510 ⁺¹²	1,058
3	325	124	1.1235E+12	0.1554	1.74592E+11	800	4.29764E+11	3.2150710 ⁺¹²	1,781
4	475	124	1.64204E+12	0.1554	2.5173E+11	1,275	6.84937E+11	5.1240110 ⁺¹²	2,839
5	725	124	2.50627E+12	0.1554	3.89474E+11	2,000	1.07441E+12	8.0376710 ⁺¹²	4,453
6	1,000	124	3.45692E+12	0.1554	5.37206E+11	3,000	1.61162E+12	1.2056510 ⁺¹³	6,680
7	1,200	119	3.98104E+12	0.1554	6.18683E+11	4,200	2.23037E+12	1.6684610 ⁺¹³	9,244
8	1,400	119	4.44939E+12	0.1554	6.91436E+11	5,600	2.92171E+12	2.1857310 ⁺¹³	12,109

Formulas:

$$C = A \times [(5,280 \text{ feet/mile})^2] \times B$$

$$E = C \times D$$

F = sum of current layer thickness plus thickness of all layers above

G = sum of current layer water volume plus water volumes of all layers above

H = G x 7.481 gallons per cubic foot

I = H/(1,805 million gallons per year); calculations are conservatively based on 100% usage of total DOE water rights.

Source: Frenzel 1995

TABLE A.3-2.—Estimated Water Storage of Main Aquifer Within the Area USGS Modeled

MODEL LAYER NO.	(A) LAYER THICKNESS (FEET)	(B) NUMBER OF ACTIVE CELLS IN REGION	(C) VOLUME OF AQUIFER IN THE LAYER (CUBIC FEET)	(D) STORAGE COEFFICIENT (CUBIC FEET OF WATER PER CUBIC FEET OF AQUIFER)	(E) VOLUME OF WATER WITHIN LAYER (CUBIC FEET)	(F) CUMULATIVE AQUIFER THICKNESS (FEET)	(G) CUMULATIVE WATER VOLUME (CUBIC FEET)	(H) CUMULATIVE WATER VOLUME (GALLONS)	(I) CUMULATIVE YEARS TO DEplete AT TOTAL WATER RIGHTS RATE (SEE TABLE A.3-3)
1	200	712	3.97×10^{12}	0.1554	6.169×10^{11}	200	6.169×10^{11}	4.61518×10^{12}	475
2	275	712	5.459×10^{12}	0.1554	8.483×10^{11}	475	1.465×10^{12}	1.0961×10^{13}	1,127
3	325	712	6.451×10^{12}	0.1554	1.002×10^{12}	800	2.468×10^{12}	1.84607×10^{13}	1,899
4	475	684	9.058×10^{12}	0.1554	1.408×10^{12}	1,275	3.875×10^{12}	2.89907×10^{13}	2,982
5	725	685	1.385×10^{13}	0.1554	2.152×10^{12}	2,000	6.027×10^{12}	4.50863×10^{13}	4,637
6	1,000	607	1.692×10^{13}	0.1554	2.63×10^{12}	3,000	8.656×10^{12}	6.47592×10^{13}	6,660
7	1,200	533	1.783×10^{13}	0.1554	2.771×10^{12}	4,200	1.143×10^{13}	8.54886×10^{13}	8,792
8	1,400	442	1.725×10^{13}	0.1554	2.681×10^{12}	5,600	1.411×10^{13}	1.05544×10^{14}	10,855

Formulas:

$$C = A \times [(5,280 \text{ feet/mile})^2] \times B$$

$$E = C \times D$$

F = Sum of current layer thickness plus thicknesses of all layers above

G = Sum of current layer water volume plus water volumes of all layers above

H = $G \times 7.481$ gallons per cubic footI = $H / (9,723 \text{ million gallons per year})$; calculations are conservatively based on 100% usage of total water rights for the Española Basin.

Source: Frenzel 1995

summary of the values used to calculate the water stored in the main aquifer within the area studied by the USGS (Figure A.3–2). These two tables also reflect the number of years it would take to deplete the water stored beneath these areas for each level modeled based on 100 percent use of water rights by the major users who draw from these areas. The total water rights used for these calculations are reflected in Table A.3–3.

It should be noted that these calculations do not consider recharge to or discharge from the aquifer or pumping from wells outside the control volume (e.g., Española, Santa Fe, San Ildefonso wells). Also, the water level changes projected by the regional MODFLOW model represent average changes over a whole grid-cell (i.e., a square that is a mile on a side). They are for the most part not predictive of the water level changes at any single point within the cell (for example, a supply well). Pumping wells have characteristic “cones of depression” where the water surface reflects an inverted cone, and water levels at the well may be quite different from levels even a few ten’s of feet away. Whether any individual well would exhibit water level changes consistent with the predicted grid-cell average change is a function of, for example, its location within the grid-cell; proximity to other pumped wells; and the individual well operation, construction, and hydraulics. Hence, the water level changes predicted by the model can only be considered

qualitatively and not be considered as finite changes.

A.4 DEVELOPMENT OF GROUNDWATER MODEL INPUT FILES

A.4.1 Water Use Projections

Table A.4.1–1 presents annual water use projections. The following processes were used to generate the numbers shown in Table A.4.1–1:

- LANL Water Use.* The SWEIS alternatives were reviewed to determine changes in water use across LANL. Because technical area (TA)–53 is a major user of water at LANL and is individually metered for water use, projections for this facility were made separate from the rest of LANL. While projections for maximum annual use were developed for the SWEIS under each alternative (for comparison to the DOE Water Rights in the Socioeconomic Analyses in chapter 5), use rates for each of the next 10 years were developed separately for the purposes of assessing drawdown of the main aquifer. These annual projections, were developed using the average annual LANL use from 1990 through 1994 (LANL 1992, LANL 1993, LANL 1994, LANL 1995, and LANL 1996). This baseline value was used for the 10-year projections, to which facilities use data (based on projected construction and operations in each alternative) were added or subtracted as appropriate. These projections include reductions of 26 million gallons (99 million liters) per year, due to the TA–16 steam plant upgrade, and 10 million gallons (38 million liters) per year, due to the High Explosives Wastewater Treatment Facility upgrade.
- Los Alamos County Water Use.* Data from 1990 through 1994 indicate an average per

TABLE A.3–3.—Water Rights for Española Basin

USER	WATER RIGHTS (GAL/YR)	TOTAL
DOE	1.805E+09	18.6%
Santa Fe	7.012E+09	72.1%
Espanola	9.060E+08	9.3%
TOTAL (J)	9.723E+09	100.0%

Source: PC 1996

TABLE A.4.1-1.—Annual Water Use Projections

	1996	1997	1998	1999	2000	2001	2002	2003	2004	2005	2006
TOTAL USE FOR LANL AND COUNTY (IN MILLION GALLONS)											
No Action	1,600	1,600	1,600	1,534	1,534	1,620	1,620	1,620	1,620	1,620	1,620
Expanded Operations	1,691	1,691	1,665	1,665	1,751	1,751	1,751	1,751	1,751	1,751	1,751
Reduced Operations	1,470	1,470	1,444	1,444	1,457	1,457	1,444	1,444	1,444	1,444	1,444
Greener	1,637	1,637	1,611	1,611	1,697	1,697	1,697	1,697	1,697	1,697	1,697
PERCENTAGE OF DOE WATER RIGHT (1,805 MILLION GALLONS)											
No Action	86%	86%	85%	85%	90%	90%	90%	90%	90%	90%	90%
Expanded Operations	94%	94%	92%	92%	97%	97%	97%	97%	97%	97%	97%
Reduced Operations	81%	81%	80%	80%	81%	81%	80%	80%	80%	80%	80%
Greener	91%	91%	89%	89%	94%	94%	94%	94%	94%	94%	94%

capita use of 155.8 gallons (589.7 liters) per day. This per capita use was applied to conservative projections (these are considered conservative because limited land availability would likely prevent the population from growing anywhere near the maximum projection) for the county population as follows: No Action, 18,969; Expanded Operations, 19,924; Reduced Operations, 17,394; and Greener, 18,969. These numbers were assumed constant through the entire 10-year period, effective January 1, 1996. These numbers were multiplied by the average per capita use figure to obtain the total Los Alamos County use figures shown. Bandelier water use is included in these calculations, because the per capita use factor included data from Bandelier.

The total use from DOE Water Rights was calculated by adding the results of the LANL use calculations and the Los Alamos County calculations.

- *Santa Fe County Water Use.* The Santa Fe County population figures used to calculate water use (Table A.4.1–2) were based on projected populations at 5-year intervals, prepared by the University of New Mexico’s (UNM’s) Bureau of Business and Economic Research (UNM 1994). A second-order polynomial was fit to the data to calculate the annual numbers shown in the second column. The number of new consumers for the public system was calculated based on estimates from Sangre de Cristo Water Company, because new developments are expected to use less water (142 gallons [540 liters] per day per person) than existing users (172 gallons [654 liters] per day per person). The per capita figure averages include irrigation and industrial use. To calculate the total public system water use, the percentage of Santa Fe County served by the Sangre de Cristo Water Company (57 percent) was assumed constant. For years 1996 through 2006, the projected water increases based on per

TABLE A.4.1–2.—Estimated Annual Water Use for Santa Fe County

YEAR	SANTA FE COUNTY POPULATION PROJECTION	NEW CONSUMERS	TOTAL WATER USE (gal./yr)	TOTAL WATER USE (acft/yr)
1993	105,089		3,741,505,919	11,481.5
1994	107,194		3,816,442,704	11,711.5
1995	109,326		3,892,360,000	11,944.4
1996	111,486	2,160	3,955,845,398	12,139.2
1997	113,674	4,347	4,020,140,288	12,336.5
1998	115,889	6,562	4,085,244,669	12,536.3
1999	118,131	8,805	4,151,158,542	12,738.6
2000	120,401	11,075	4,217,881,905	12,943.4
2001	122,699	13,372	4,285,414,760	13,150.6
2002	125,024	15,697	4,353,757,106	13,360.3
2003	127,376	18,050	4,422,908,944	13,572.5
2004	129,376	20,430	4,492,870,273	13,787.2
2005	132,164	22,838	4,563,641,093	14,004.4
2006	134,599	25,273	4,635,221,404	14,224.0

gal./yr = gallons per year

acft/yr = acre-feet per year

capita increases were added to the actual water use value for 1995.

A.4.2 Other Input Files and Information

Frenzel's model (1995) for north-central New Mexico, was used with no changes to any hydraulic parameters and no additional calibration. Data on water use from individual DOE and Santa Fe wells from 1993 through 1995 were obtained from the state engineers office and added to Frenzel's well input file, which used pumping data through 1992 (Frenzel 1995). Changes were made only to well pumping rates calculated from the water use projections. The process below describes the procedure for reducing annual total well field production to pumping from each model layer for each individual well. This process was performed for each alternative.

- To allocate the total use for the DOE and Santa Fe supply systems among individual wells, a spreadsheet was developed to calculate average percentage of the total produced by each well field from 1993 through 1995. In turn, the average proportion of the total well field production supplied by each individual well within the field was calculated from 1993 through 1995.
- For projected pumping rates for each well based on water use projections, a spreadsheet was developed based on Frenzel's (1995) Table 11. Frenzel's Table 11 allocates the percentage of pumping from layers one through five for each well. These percentages were multiplied by each well's total annual projected pumping to obtain the proper flow rate from each layer.
- Based on conversations with representatives of the Sangre de Cristo Water Company (Santa Fe County's public supplier) in 1995, Santa Fe plans to start taking their San Juan-Chama water right (5,605 acre-feet [or 1,827 million gallons

(6,913 million liters)] per year) from the Rio Grande through a diversion pipeline (Santa Fe Diversion). When the collection system for the Rio Grande is on-line, Santa Fe will shut down the Buckman well field and use it only for supply emergencies.

A.5 MODEL RESULTS

Based on the Frenzel model, the total approximate volume of water within the 5,600-foot (1,707-meter) thickness of the main aquifer below the Pajarito Plateau is estimated to be 21.8 trillion gallons (82,513 million cubic meters). Water quality will generally become increasingly poor with increasing depth. Therefore, the amount of potable water may be far less than the total volume available. Available data are insufficient to model water quality degradation with depth; but, water supply wells screened as deep as 1,830 feet (558 meters) into the main aquifer produce potable water that meets *Safe Drinking Water Act* standards (42 United States Code [U.S.C.] §300).

A similar water storage analysis for the main aquifer beneath the entire USGS modeled area shows that 106 trillion gallons (401 trillion liters) of water are stored. This estimate of storage volume is conservative, as the USGS model does not include the entire Española Basin. Use of groundwater from the Española Basin at combined annual water rights rates for DOE (1,805 million gallons [6,832 million liters] per year); Santa Fe (7,012 million gallons [26,540 million liters] per year); and Española (906 million gallons [3,429 million liters] per year) indicates that if the upper 1,275 feet (389 meters) of the Basin were used, a water supply would be available for 2,982 years and if the upper 2,000 feet (610 meters) of the Basin were used, a water supply would be available for 4,637 years.

A.5.1 Changes in Water Levels and Storage in the Main Aquifer

The model results reflect water level changes at the top of the main aquifer across the alternatives, given continued draw from the aquifer by DOE, Española, and Santa Fe. Table A.5.1–1 shows predicted water level changes at the surface of the main aquifer during the period from 1996 through 2006 for each of the SWEIS alternatives. Although the water use modeled includes water use in Española and Santa Fe, the differences between the alternatives are due only to LANL operations.

The groundwater model indicates that no springs in White Rock Canyon are likely to go dry. Springs in White Rock Canyon in the vicinity of the Buckman well field may actually increase in flow due to rising groundwater levels (from 0.1 to 3.8 feet [0.03 to 1.2 meters]). The rising water levels result from the continuing recovery in the vicinity of the Los Alamos well field, which was shut down in 1992, and recovery in the vicinity of Santa Fe’s Buckman well field, which is planned for shut down in 1999. Operations of both well fields are independent of the alternatives and significantly affect water levels in the main aquifer in the vicinity of the Rio Grande.

TABLE A.5.1–1.—Maximum Water Level Changes at the Top of the Main Aquifer Due to All Users Combined (1996 Through 2006)

	WATER LEVEL CHANGE IN FEET ^a			
	NO ACTION	EXPANDED	REDUCED	GREENER
AREA OF CONCERN ON-SITE				
Pajarito Well Field	-13.2	-15.6	-10.7	-14.5
Otowi Well Field (Well 0–4)	-12.9	-15.2	-10.3	-14.2
AREA OF CONCERN OFF-SITE				
DOE - Guaje Well Field	-8.7	-9.3	-8.1	-9.0
Santa Fe Water Supply				
Buckman Well Field	+21.6	+21.6	+21.7	+21.6
Santa Fe Well field	-20.6	-20.6	-20.6	-20.6
San Juan Chama Diversion	0.0	0.0	0.0	0.0
Springs				
White Rock Canyon Springs, maximum drop	0.0	0.0	0.0	0.0
White Rock Canyon Springs, maximum rise	+1.0	+1.0	+1.0	+1.0
Other Springs (Sacred, Indian)	+3.8	+3.8	+3.8	+3.8
San Idefonso Pueblo Supply Wells				
<i>West of Rio Grande:</i>				
Household, Community Wells	+0.6	+0.6	+0.6	+0.6
Los Alamos Well Field	+3.8	+3.8	+3.8	+3.8
<i>East of Rio Grande:</i>				
Household, Community Wells	0.0	0.0	0.0	0.0

^a Negative value (-) indicates water level drop; positive value (+) indicates water level rise.

In comparison to the thicknesses of the eight model layers (total equals 5,600 feet [1,707 meters]), the maximum drawdown predicted over the next 10 years for DOE well fields (15.6 feet [4.8 meters] for the Pajarito well field) represents a reduction of main aquifer saturated thickness of 0.28 percent. Water use projections indicate that the maximum total volume of water to be withdrawn from DOE well fields from 1996 through 2006 is 19 billion gallons (72 billion liters), which is 0.09 percent of the main aquifer volume (22 trillion gallons [83 trillion liters]) of water in storage beneath the Pajarito Plateau. In summary, the drawdowns in DOE well fields are minimal relative to the total thickness of the main aquifer, and the volume of water to be used over the period from 1996 through 2006 is negligible relative to the volume of water in storage.

The water level declines reflected here could have an impact on the water levels in off-site wells that are used by other entities, which would require these entities to drill deeper wells into the aquifer.

A.6 MODEL UNCERTAINTIES AND LIMITATIONS

The following uncertainties and limitations associated with the use of this model should be noted:

- The model only includes a portion of the main aquifer. No model or method exists to predict changes of water levels in the vicinity of springs emanating from intermediate perched groundwater bodies (Basalt Spring, S-Site (TA-16) Springs, Water Canyon Gallery).
- The model's mile-square grid spacing underestimates drawdowns at individual wells. The grid spacing is also too large to precisely model changes in water levels in the main aquifer adjacent to the Rio Grande in response to the Santa Fe diversion. A finer-scale model is under development by the Sangre de Cristo Water Company.
- No additional calibration was performed, even though Otowi-4 pumping, initiated after Frenzel's model was calibrated, may make additional calibration technically desirable.
- Because water levels at the Pueblo of San Ildefonso are not available, modeled water level changes are the only data available.
- The remainder of Santa Fe County is served by approximately 16,000 domestic wells, each of which has rights to 3 acre-feet (0.98 million gallons [3.7 million liters]) per year. These are far more private wells than were included in the model (200). This factor probably does not significantly change model drawdown results for the following reasons: most private users probably use much less than 3 acre-feet (0.98 million gallons [3.7 million liters]) per year, the private wells extract only from layer one or shallower perched zones (public supply wells pump from layers two through five), and private wells are sufficiently spread out so that impacts from one location are not observed at other nearby wells.

REFERENCES

- Bradford 1996 Memorandum from W. Bradford, ESH-EIS, to Doris Garvey, ESH/M889. Subject: NPDES Outfalls and Annual Volume Discharges for Other than Key Facilities. August 28, 1996.
- Frenzel 1995 *Geohydrology and Simulation of Groundwater Flow Near Los Alamos, North-Central New Mexico*. Water Resources Investigations Report 95-4091. U.S. Geological Survey. Washington, D.C. 1995.
- Garvey 1997 Memorandum from D. Garvey, ESH-EIS, to Corey Cruz, DOE Albuquerque Operations Office. Subject: NPDES outfalls. December 19, 1997.
- LANL 1992 *Environmental Surveillance at Los Alamos During 1990*. Los Alamos National Laboratory. LA-12271-M8. UC-902. Los Alamos, New Mexico. March 1992.
- LANL 1993 *Environmental Surveillance at Los Alamos During 1991*. Los Alamos National Laboratory. LA-12572-ENV. UC-902. Los Alamos, New Mexico. August 1993.
- LANL 1994 *Environmental Surveillance at Los Alamos During 1992*. Los Alamos National Laboratory. LA-12764-MS. UC-902. Los Alamos, New Mexico. July 1994.
- LANL 1995 *Environmental Surveillance at Los Alamos During 1993*. Los Alamos National Laboratory. LA-12973-ENV. UC-902. Los Alamos, New Mexico. October 1995.
- LANL 1996 *Environmental Surveillance at Los Alamos During 1994*. Los Alamos National Laboratory. LA-13047-ENV. UC-902. Los Alamos, New Mexico. July 1996.
- LANL 1998 *Los Alamos National Laboratory Hydrogeologic Workplan*. Los Alamos National Laboratory. Los Alamos, New Mexico. May 1998.
- PC 1996 E. Rogoff, GRAM, Inc. Personal communication with T. Thompson, New Mexico State Engineer, regarding information on water rights for Española and Santa Fe. June 11, 1996.
- Purtymun 1984 *Hydrologic Characteristics of the Main Aquifer in the Los Alamos Area: Development of Ground Water Supplies*. W. D. Purtymun. Los Alamos National Laboratory. LA-9957-MS. Los Alamos, New Mexico. 1984.

- Rogers and
Gallaher 1995 *The Unsaturated Hydraulic Characteristics of the Bandelier Tuff*. D. B. Rogers
and B. M. Gallaher. Los Alamos National Laboratory. LA-12968-MS.
UC-903. Los Alamos, New Mexico. September 1995.
- Rogers et al. 1996 “Recharge to the Pajarito Plateau Aquifer System.” D. B. Rogers, A. K. Stoker,
S. G. McLin, and B. M. Gallaher. *1996 Guidebook, Geology of the Los
Alamos—Jemez Mountains Region*. Los Alamos National Laboratory.
LA-UR-96-486. New Mexico Geological Society. Los Alamos, New Mexico.
1996.
- UNM 1994 *Population Projections for the State of New Mexico by Age and Sex,
1990–2020*. University of New Mexico, Bureau of Business and Economic
Research. Albuquerque, New Mexico. May 1994.

APPENDIX B

AIR QUALITY

This appendix provides supplemental information regarding the air quality analyses presented in chapter 5. This appendix addresses aspects of both radiological air emissions and nonradiological air emissions.

B.1 RADIOLOGICAL AIR QUALITY

B.1.1 Methodology

The radiological air quality analyses address:

- *Facility-Specific Maximally Exposed Individual (FS MEI)*—The FS MEI represents a location near a facility that is modeled as having the greatest dose to a hypothetical public individual from all modeled emissions under a given SWEIS alternative.
- *LANL Site-Wide Maximally Exposed Individual*—The LANL MEI represents the location of the single highest modeled dose to a hypothetical public individual. Under a given alternative, the highest FS MEI becomes the LANL MEI for that alternative.
- Collective dose to the population within a 50-mile (80-kilometer) radius from LANL.

In addition to these receptors, isodose maps were developed that show the estimated committed effective dose equivalents (CEDEs) at any location within the 50-mile (80-kilometer) radius. These maps were developed to allow individuals within the 50-mile (80-kilometer) radius to estimate their modeled CEDE.

In order to enable these analyses, a review of historical emissions was undertaken for the period 1990 through 1994. The data were largely derived from past National Emission Standards for Hazardous Air Pollutants

(NESHAP) reports. The data reviewed are summarized in Table B.1.1–1. The data show the CEDE to the LANL MEI. Although valid, these data were only available for the LANL MEI, not for the FS MEI.

MEIs are hypothetical individuals who do not leave and do not take protective actions to avoid exposure. The risk from ionizing radiation consists mostly of some number of excess latent cancer fatalities (LCFs). These are cancers resulting from, and that develop well after, the exposure to ionizing radiation. These represent an increase in the number of fatal cancers that occur from other causes. The excess LCF is the product of the dose and the risk factor of 5×10^{-4} excess LCF per person-rem. The reader should recognize that these estimates are intended to provide a conservative measure of the potential impacts to be used in the decision-making process and do not necessarily portray an accurate representation of actual anticipated fatalities. In other words, one could expect that the stated impacts form an upper bound and that actual consequences could be less, but probably would not be worse. This is discussed in the primer on the effects of radiation in section D.1 of appendix D, Human Health.

B.1.1.1 Modeled Facilities

Several facilities at LANL emit radioactive materials to the ambient air through stacks, vents, or diffuse emissions. Not all of the facilities listed in Table B.1.1–1 were modeled for this SWEIS. Those facilities not modeled were eliminated from such detailed analysis because they have historically low emission rates or because they are not expected to operate during the period analyzed in the SWEIS. The facilities modeled include 16 emission points from 12 facilities within 10 TAs. These facilities are listed in Table B.1.1.1–1. These

TABLE B.1.1-1.—Historical Summary of Dose Estimates to LANL’s Maximally Exposed Individual from Radioactive Air Emissions (1990 Through 1994)

MODELED EFFECTIVE DOSE EQUIVALENT (mrem/yr) TO LANL’S MEI FROM AIRBORNE RELEASES							
	1990 ^a	1991 ^a	1992	1993	1994	AVERAGE ^b	PERCENT
EDE (mrem/yr) from point and nonpoint sources	15.3	6.5	7.9	5.6	7.6	7.33	
POINT SOURCES							
LA-1:TA-2 (Omega West Reactor)	NA	NA	0.0061	0.000061	0.0000255	0.00206	0.028
TA-41 (Weapons Material Fabrication)							
LA-2: TA-3 (CMR Laboratory, Van de Graff)	NA	NA	0.00164	0.00277	0.00188	0.00210	0.029
LA-4:TA-33 (Old Tritium Handling Facility)	NA	NA	9.00 x 10 ⁻⁶	0.0000100	0.000014	0.0000110	0.002
LA-5:TA-21, TA-35, TA-43, TA-48, TA-50, TA-55	NA	NA	0.0012	0.0244	0.0173	0.0176	0.241
LA-5a:TA-21					0.0167		
LA-5b:TA-35, TA-50, TA-55					0.0000528		
LA-5c:TA-43					4.11 x 10 ⁻⁶		
LA-5d:TA-48					0.000528		
LA-6:TA-53 (LANSCÉ)	NA	NA	7.83	4.57	6.74	6.38	87.0
LA-7:TA-54 (Waste Disposal Site)	NA	NA	4.08 x 10 ⁻⁸	0	6.54 x 10 ⁻⁸	3.54 x 10 ⁻⁸	0.00000
Total Point Source			7.85	4.597	6.78	6.40	87.3
NONPOINT SOURCES							
LA-3:TA-15 (PHERMEX), TA-36 (Open-Air Explosive Tests Sites)	NA	NA	0.009	0.066	0.16	0.030	0.414
LA-8:TA-54 (Active Storage and Disposal Site)	NA	NA	NA	0.0007	0.0000540	0.0000610	0.001
LA-9:TA-6, TA-21, TA-33, TA-49, TA-54 (Inactive Storage and Disposal Sites)	NA	NA	NA	NA	NA		
LA-11:TA-14, TA-15, TA-36, TA-39 (Residual Materials at Inactive Firing Sites)	NA	NA	NA	NA	NA		

TABLE B.1.1-1.—Historical Summary of Dose Estimates to LANL's Maximally Exposed Individual from Radioactive Air Emissions (1990 Through 1994)-Continued

MODELED EFFECTIVE DOSE EQUIVALENT (mrem/yr) TO LANL'S MEI FROM AIRBORNE RELEASES							
	1990 ^a	1991 ^a	1992	1993	1994	AVERAGE ^b	PERCENT
LA-12:TA-53 (Effluent Release to Holding Ponds)	NA	NA	0.00083	1.90×10^{-7}	0.0088	0.003	0.044
LA-13:TA-53 (Residual Radionuclides in Ponds)	NA	NA	NA	NA	NA		
LA-14: TA-50 (Liquid Release to Canyon)	NA	NA	0.00014	0.00210	1.80×10^{-7}	0.001	0.01
LA-15:TA-2, TA-41, TA-45, TA-50 (Residual Radionuclides in Canyon)	NA	NA	NA	NA	NA		
LA-16:TA-53 (Fugitive Emissions)	NA	NA	NA	1.0	0.8	0.900	12.28
LA-17:TA-21, TA-33 (Fugitive Emissions from Decontamination and Decommissioning Facilities)	NA	NA	NA	0.014	NA		
Total from Nonpoint Sources			0.00997	1.07	0.82	0.934	12.7

Notes:

NA = Not available (data were not available for that site that year), LANSCE = Los Alamos Neutron Science Center, PHERMEX = Pulsed High-Energy Radiation Machine Emitting X-Ray Facility

^a The effective dose equivalent to the LANL MEI was not reported from individual facilities in 1990 and 1991. The only value reported in those years was the total dose (from all facilities combined) to the LANL MEI.

^b Because the detailed individual source contributions are not available for 1990 and 1991, this average has been calculated for the 3-year period from 1992 to 1994.

TABLE B.1.1.1-1.—List of Facilities Modeled for Radionuclide Air Emissions from LANL

FACILITIES	
TA-3-29	CMR Building
TA-3-66	Sigma Building
TA-3-102	Machine Shops
TA-11	High Explosives (HE) Testing
TA-15/36	Firing Sites
TA-16	WETF
TA-18	Pajarito Site: LACEF
TA-21	TSTA and TSFF
TA-48	Radiochemistry Laboratory
TA-53	LANSCE ^a
TA-54	Area G
TA-55	Plutonium Facility

Notes:

^a Five specific sources were modeled from TA-53. These include the TA-53 Exhaust Stack-2 (ES-2), Exhaust Stack-3 (ES-3), Isotope Production Facility (IPF), Low-Energy Demonstration Accelerator (LEDA), and combined diffuse emissions.

CMR = Chemistry and Metallurgy Research, WETF = Weapons Engineering Tritium Facility, LACEF = Los Alamos Critical Experiments Facility, TSTA = Tritium System Test Assembly, TSFF = Tritium Science Fabrication Facility

facilities historically have emitted the majority of radioactive materials to the air or were affected by the SWEIS alternatives.

Emission projections were made by alternative for each of these facilities. These estimates were based on historical activity levels and emissions and the SWEIS alternative descriptions. These estimates served as the basis for modeling the consequences of LANL radiological air emissions.

B.1.1.2 Selection of the CAP-88 Model

Based on estimated emission rates under various alternatives, air dispersion modeling was performed to evaluate the radiation doses

(CEDEs) from these emissions. The *Clean Air Act* Assessment Package-1988 (CAP-88) (EPA 1992a) is one such air dispersion model. It was selected to perform dose calculations. CAP-88 contains a modified Gaussian plume model that estimates the average dispersion of radionuclides released from up to six sources simultaneously. The model may be run on individual sources as well. The sources may be elevated stacks or uniform area (diffuse) sources. The program computes radionuclide concentrations in air, rates of deposition on ground surfaces, concentrations in food from radionuclides emitted to the air, and intake rates for people from ingestion of food produced in the assessment area. The model calculates the CEDE resulting from these air emissions and resulting exposure pathways.

CAP-88 was chosen for the following reasons:

- CAP-88 is approved by the U.S. Environmental Protection Agency (EPA) for demonstrating compliance with the NESHAP (40 Code of Federal Regulations [CFR] 61, Subpart H) and is used by LANL and other DOE facilities for that purpose. Consequently, DOE and LANL have experience with this code, and it is acceptable to other regulatory agencies.
- CAP-88 is known to compare favorably with other models for producing results that generally agree with experimental data.
- To support NESHAP estimates, the LANL mainframe version of CAP-88 was previously modified to include special radionuclides emitted by the Los Alamos Neutron Science Center (LANSCE). Those radionuclides are mainly activation products that are not modeled by the personal computer version or by other air dispersion models, such as the Generation II (GENII) model prepared for DOE by Pacific Northwest Laboratory.
- CAP-88 adequately accounts for both point sources and diffuse sources, which are both present at LANL.

- Other models (such as GENII) do not have any significant advantages over CAP-88 that would negate its use.

B.1.1.3 *Limitations of the CAP-88 Model*

As in all computer models, there are some limitations in the CAP-88 model. These limitations were considered prior to the use of this model but were dismissed. The most important limitations are described below.

- While up to six sources can be modeled in a single run, all the sources are assumed to be at the same geographic point during the modeling run. This was overcome by performing separate model runs for each source.
- CAP-88 assumes a flat terrain during the radionuclide transport. Complex terrain cannot be modeled by CAP-88. This effect was considered negligible when the distance to the exposed individuals is large compared to the stack height, area, or facility size. The flat terrain model is customary and used elsewhere to model LANL emissions.
- The model assumes that individuals remain at locations 24 hours a day, 365 days a year, when estimating the dose for that specific location. This is obviously unlikely but provides worst-case bounding conditions.
- CAP-88 calculates the dose from external radiation from radionuclides in the air that envelops the receptor. However, if the radionuclide cloud is only overhead and not in touch with the ground, the radiation dose is not calculated. This is not regarded as a serious shortcoming because of the absorption of the radiation in air and CAP-88's overestimate of the dose once the cloud has touched down. In most past years, environmental monitors have shown lower exposures than were calculated using CAP-88.

B.1.1.4 *Model Input Parameters*

The CAP-88 model requires many input parameters in order to perform dose calculations. Most of these parameters are built into the model and require no input from the user. However, some parameters (such as the amount of radionuclide emitted) must be introduced by the user. These user-defined inputs are discussed below, along with how the data were derived.

Radionuclide Emission Rate Data

Radionuclide emission rate projections for each alternative were introduced into the CAP-88 model. Some modeled facilities have more than one emission point, depending on the operations within the facilities. For example, TA-53 has five emission points, which were modeled separately. The radionuclides emitted and their modeled emission rates for each facility are summarized in Tables B.1.1.4-1 through B.1.1.4-17.

All radionuclide emissions were modeled using the personal computer version of CAP-88, except when the radionuclides contain mixed activation products (MAPs). In those cases, the LANL mainframe version of CAP-88 was used for modeling. The only two modeled facilities that required the use of LANL mainframe computers were TA-48 and TA-53.

Some assumptions had to be made while modeling some radionuclide emissions from LANL. In all cases, the most conservative assumption was selected for use, resulting in an overestimation of the committed effective dose equivalents. These assumptions are:

- Actinide and particulate emissions from the Chemistry and Metallurgy
- Research (CMR) Building and TA-55 were not modeled by radionuclide. All actinide and particulate emissions from these facilities were assumed to be plutonium-239.

TABLE B.1.1.4-1.—Radiological Air Emissions from TA-3-29 (CMR)

STACK NUMBER	WING 2	WING 4	WING 9
	ES-14	ES-24	ES-46
STACK PARAMETERS			
Height (meters)	15.9	15.9	21.5
Diameter (meters)	1.1	1.1	2.1
Exit Velocity (meters per second)	6.8	14.6	1.9
EMISSION RATE PER STACK (CURIES PER YEAR)			
No Action Alternative			
Actinides (plutonium-239) ^a	0.000420		
Expanded Operations Alternative			
Actinides (plutonium-239) ^a	0.000760		
Fission Products ^b			
Krypton-85			100
Xenon-131m			23,480
Xenon-133			1,500
Tritium ^c		1,000	
Reduced Operations Alternative^d			
Actinides (plutonium-239) ^a	0.000380		
Greener Alternative^d			
Actinides (plutonium-239) ^a	0.000420		

Notes:

^a Actinides were not broken down by isotope; therefore, they were represented by plutonium-239. Actinides are emitted from Wings 2, 3, 4, 5, 6, 7, and 9, but no stacks were specified. The most conservative stack was chosen (ES-14 at Wing 2) to model emissions from all these wings.

^b Fission product emissions apply only to the Expanded Operations Alternative. Fission products are emitted from Wing 9. The most conservative stack (ES-46) was chosen for modeling.

^c Tritium emissions apply only to the Expanded Operations Alternative. Tritium is emitted from Wing 4. A new stack will be installed for it; no information on the stack parameters is available. The most conservative stack (ES-24) was chosen to model all tritium emissions from Wing 4.

^d The No Action and Greener Alternatives are the same. The Reduced Operations Alternative is 90 percent of the No Action Alternative.

TABLE B.1.1.4-2.—Radiological Air Emissions from TA-3-66 (Sigma)

STACK NUMBER						
	ES-1	ES-8	ES-9	ES-13 ^a	ES-24 ^a	ES-25/26 ^{b,c}
Percent Emissions ^d Uranium-238	2	2	2	45	45	4
STACK PARAMETERS						
Height (meters)	19.8	16.8	15.4	13.7	15.9	12.2
Diameter (meters)	1.2	2.8	1.8	0.4	1.1	0.3
Exit Velocity (meters per second)	14.4	1.1	4.9	51.8	14.6	1.8
EMISSION RATE PER STACK (CURIES PER YEAR) ^e						
No Action Alternative						
Uranium-234	0	0	0	0	0	0.0000220
Uranium-238	0.0000122	0.0000122	0.0000122	0.000275	0.000275	0.0000244
Expanded Operations Alternative						
Uranium-234	0	0	0	0	0	0.0000660
Uranium-238	0.0000360	0.0000360	0.0000360	0.000810	0.000810	0.0000720
Reduced Operations Alternative						
Uranium-234	0	0	0	0	0	0.0000220
Uranium-238	0.0000122	0.0000122	0.0000122	0.000275	0.000275	0.0000244
Greener Alternative						
Uranium-234	0	0	0	0	0	0.0000220
Uranium-238	0.0000122	0.0000122	0.0000122	0.000275	0.000275	0.0000244

Notes:

^a 90 percent of the depleted uranium (DU) (e.g., uranium-238) comes out of ES-13 and ES-24 (i.e., 45% each).^b No stack information is available for enriched uranium (EU) emissions; therefore, the most conservative emission stack (ES) is considered for emissions (stack ES-25).^c Stack ES-26 is added to stack ES-25 for similarity of parameters.^d All uranium-238 is assumed to be in equilibrium with thorium-234 and protactinium-234m. All DU is considered as uranium-238, and all EU is considered as uranium-234.^e The No Action, Greener, and Reduced Operations Alternatives are the same. The Expanded Operations Alternative is three times higher than the No Action Alternative.

TABLE B.1.1.4-3.—Radiological Air Emissions from TA-11 (High Explosives Testing)

RADIONUCLIDE	ALTERNATIVE (CURIES PER YEAR)			
	NO ACTION	EXPANDED OPERATIONS	REDUCED OPERATIONS	GREENER
Uranium-238 ^a	3.98×10^{-7}	9.96×10^{-7}	2.32×10^{-7}	2.32×10^{-7}
Uranium-235 ^b	7.56×10^{-9}	1.89×10^{-8}	4.41×10^{-9}	4.41×10^{-9}
Uranium-234 ^c	1.49×10^{-7}	3.71×10^{-7}	8.67×10^{-8}	8.67×10^{-8}

Notes:

^a Protactinium-234m and thorium-234 are in equilibrium with uranium-238.^b Thorium-231 is in equilibrium with uranium-235.^c No stack emissions. This is an area source. An area of 10,000 square meters (m²) was used. Areas of 100 and 1,000 m² were also used, with no difference in the results.**TABLE B.1.1.4-4.—Radiological Air Emissions from TA-16 (Tritium Facility)**

RADIONUCLIDE ^{a,b}	ALTERNATIVE (CURIES PER YEAR)			
	NO ACTION	EXPANDED OPERATIONS	REDUCED OPERATIONS	GREENER
Tritium (gaseous)	100	300	100	100
Tritium (water vapor)	300	500	300	300
Total	400	800	400	400

Notes:

^a Tritium is emitted in the gaseous form (HT) as well as in the water vapor form (HTO). CAP-88 uses the water vapor form of tritium for modeling for a conservative result because the vapor form produces the highest dose. It was assumed that all tritium is in the vapor form.^b Tritium is emitted from fan exhaust (FE)-4 in Building 205 (the only stack for tritium emissions at TA-16). The stack parameters are: Height = 18.3 meters, Diameter = 0.5 meter, and Exit Velocity = 19.3 meters per second.**TABLE B.1.1.4-5.—Radiological Air Emissions from TA-18 (Pajarito Site)**

RADIONUCLIDE ^{a,b}	ALTERNATIVE (CURIES PER YEAR)			
	NO ACTION	EXPANDED OPERATIONS	REDUCED OPERATIONS	GREENER
Argon-41	101	126	101	101

Notes:

^a No stack emissions. This is an area source. An area of 45,200 square meters (m²) was calculated based on the air volume used by LANL to calculate the emission rates.^b Argon-41 is the only significant radionuclide emitted from TA-18. Others are present in quantities too small to consider in this analysis.

TABLE B.1.1.4-6.—Radiological Air Emissions from TA-21 (Tritium Facility)

RADIONUCLIDE ^a	ALTERNATIVE (CURIES PER YEAR)			
	NO ACTION	EXPANDED OPERATIONS	REDUCED OPERATIONS	GREENER
TA-21-155^b				
Tritium (gaseous)	100	100	100	100
Tritium (water vapor)	100	100	100	100
Total	200	200	200	200
TA-21-209^c				
Tritium (gaseous)	640	640	640	640
Tritium (water vapor)	860	860	860	860
Total	1,500	1,500	1,500	1,500

Notes:

^a Tritium is emitted in the gaseous form (HT) as well as in the water vapor form (HTO). CAP-88 uses the water vapor form of tritium for modeling for a conservative result, because the vapor form produces the highest dose. It was assumed that all tritium is in the vapor form.

^b The ES-5 stack parameters for TA-21-155 are: Height = 29.9 meters (m), Diameter = 0.8 m, Exit Velocity = 7.8 meters per second (m/s).

^c The ES-1 stack parameters for TA-21-209 are: Height = 23.2 m, Diameter = 1.2 m, Exit Velocity = 10.3 m/s.

TABLE B.1.1.4-7.—Radiological Air Emissions from TA-3-102 (Shops)

RADIONUCLIDE ^{a,b}	ALTERNATIVE (CURIES PER YEAR)			
	NO ACTION	EXPANDED OPERATIONS	REDUCED OPERATIONS	GREENER
Uranium-238	0.00005	0.00015	0.00005	0.00005

Notes:

^a Protactinium-234m and thorium-234 are in equilibrium with uranium-238.

^b The ES-22 stack parameters are: Height = 11.9 meters, Diameter = 0.9 meter, Exit Velocity = 0.8 meters per second.

TABLE B.1.1.4-8.—Radiological Air Emissions from TA-48 (Radiochemistry Laboratory)

FAN EXHAUST (FE) NUMBER (STACK NUMBER)				
	FE-15 (16)	FE-4 (11)^a	FE-45/46	FE-51/54
FAN EXHAUST PARAMETERS				
Height (meters)	19.8	20.1	15.2	13.1
Diameter (meters)	1.5	1.8	1.8	0.9
Velocity (meters per second)	13.5	9.9	8.2	7.9
EMISSION RATE PER FAN EXHAUST (CURIES PER YEAR)				
No Action Alternative				
Mixed Fission Product ^b	0.000015	0.00008	0.0000126	1.10 x 10 ⁻⁶
Plutonium-239	4.50 x 10 ⁻⁶	4.70 x 10 ⁻⁷	4.70 x 10 ⁻⁷	6.20 x 10 ⁻⁸
Expanded Operations Alternative				
Mixed Fission Product ^b	0.000033	0.000088	0.000018	2.20 x 10 ⁻⁶
Plutonium-239	9.60 x 10 ⁻⁶	5.20 x 10 ⁻⁷	6.50 x 10 ⁻⁷	1.20 x 10 ⁻⁷
Reduced Operations Alternative				
Mixed Fission Product ^b	0.000015	0.00004	0.000013	5.30 x 10 ⁻⁷
Plutonium-239	4.50 x 10 ⁻⁶	2.40 x 10 ⁻⁷	4.60 x 10 ⁻⁷	3.10 x 10 ⁻⁸
Greener Alternative				
Mixed Fission Product ^b	0.000033	0.00008	0.000018	1.10 x 10 ⁻⁶
Plutonium-239	9.60 x 10 ⁻⁶	4.70E x 10 ⁻⁷	6.50 x 10 ⁻⁷	6.20 x 10 ⁻⁸

Notes:

^a Fan exhaust FE-4 exits through Stack 11.^b The mixed fission products are represented by strontium-90/yttrium-90 in equilibrium.

TABLE B.1.1.4-9.—Radiological Air Emissions from TA-48 (Radiochemistry Laboratory)^a

ALTERNATIVE	NO ACTION		EXPANDED OPERATIONS		REDUCED OPERATIONS		GREENER	
	FE-60	FE-63/64	FE-60	FE-63/64 ^b	FE-60	FE-63/64	FE-60	FE-63/64
FAN EXHAUST PARAMETERS								
Height (meters)	12.4	10.3	12.4	10.3	12.4	10.3	12.4	10.3
Diameter (meters)	0.4	0.4	0.4	0.4	0.4	0.4	0.4	0.4
Exit Velocity (meters per second)	9.4	12.5	9.4	12.5	9.4	12.5	9.4	12.5
EMISSION RATE PER FAN EXHAUST (CURIES PER YEAR)								
Emission:								
Mixed Activation Products ^c	1.60 x 10 ⁻⁷	1.40 x 10 ⁻⁶	3.20 x 10 ⁻⁷	2.80 x 10 ⁻⁶	8.00 x 10 ⁻⁸	7.00 x 10 ⁻⁷	1.60 x 10 ⁻⁷	1.40 x 10 ⁻⁶
Arsenic-72	0	0.000056	0	0.00011	0	0.000028	0	0.000056
Arsenic-73	0	0.000095	0	0.00019	0	0.0000475	0	0.000095
Arsenic-74	8.50 x 10 ⁻⁷	0.000019	1.70 x 10 ⁻⁶	0.000038	4.25 x 10 ⁻⁷	9.50 x 10 ⁻⁶	8.50 x 10 ⁻⁷	0.000019
Beryllium-7	7.30 x 10 ⁻⁶	6.10 x 10 ⁻⁸	0.000015	1.20 x 10 ⁻⁷	3.65 x 10 ⁻⁶	3.05 x 10 ⁻⁸	7.30 x 10 ⁻⁶	6.10 x 10 ⁻⁸
Bromine-77	0.00031	0.00012	0.00062	0.00024	0.000155	0.00006	0.00031	0.00012
Germanium-68	0	8.50 x 10 ⁻⁶	0	0.000017	0	4.25 x 10 ⁻⁶	0	8.50 x 10 ⁻⁶
Rubidium-86	0	1.40 x 10 ⁻⁷	0	2.80 x 10 ⁻⁷	0	7.00 x 10 ⁻⁸	0	1.40 x 10 ⁻⁷
Selenium-75	0.000044	0.00012	0.000089	0.00024	0.000022	0.00006	0.000044	0.00012

Notes:

^a These isotopes were modeled using LANL's mainframe computer.^b Fan exhausts FE-63/64 exit through Stack 7.^c The mixed activation products are represented by strontium-90/yttrium-90 in equilibrium.**TABLE B.1.1.4-10.—Radiological Air Emissions from TA-55 (Plutonium Facility)**

RADIONUCLIDE	ALTERNATIVE (CURIES PER YEAR)			
	NO ACTION	EXPANDED OPERATIONS	REDUCED OPERATIONS	GREENER
ES-15 (North Stack) ^a	1.52 x 10 ⁻⁶	2.50 x 10 ⁻⁶	1.38 x 10 ⁻⁶	2.00 x 10 ⁻⁶
ES-16 (South Stack) ^b				
Particulates (plutonium-239) ^c	0.0000162	0.000026	7.91 x 10 ⁻⁶	0.0000157
Tritium	1,000	100	100	100

Notes:

^a The ES-15 stack parameters are: Height = 14 meters (m), Diameter = 1.1 m, and Exit Velocity = 6.8 meters per second (m/s).^b The ES-16 stack parameters are: Height = 14 m, Diameter = 1.1 m, and Exit Velocity = 10.8 m/s.^c No isotopic breakdown of particulates is available; therefore, all particulates are represented by plutonium-239.

TABLE B.1.1.4-11.—Radiological Air Emissions from TA-15 and TA-36 (Firing Sites)

ALTERNATIVE	RADIONUCLIDE (CURIES PER YEAR) ^{a,b}		
	URANIUM-238	URANIUM-235	URANIUM-234
NO ACTION			
TA-15	0.0226	0.000437	0.00842
TA-36	0.012	0.000233	0.00449
Total	0.0346	0.00067	0.0129
EXPANDED OPERATIONS			
TA-15	0.0693	0.00134	0.0258
TA-36	0.0346	0.00067	0.0129
Total	0.104	0.00201	0.0387
REDUCED OPERATIONS			
TA-15	0.0226	0.000437	0.00842
TA-36	0.012	0.000233	0.00449
Total	0.0346	0.00067	0.0129
GREENER			
TA-15	0.0226	0.000437	0.00842
TA-36	0.012	0.000233	0.00449
Total	0.0346	0.00067	0.0129

Notes:

^a No stack emissions. This is an area source. An area of 100 square meters was used. This value was used based on information obtained from LANL personnel regarding the area of pads used for firing experiments.

^b These values are for the resuspendable and/or respirable portion of the product used during the tests and as such are the values used as the source parameter in the CAP-88 PC Model.

TABLE B.1.1.4-12.—Radiological Air Emissions from TA-54 (Area G—Waste Management)

RADIONUCLIDE ^b	ALTERNATIVE (CURIES PER YEAR) ^a			
	NO ACTION	EXPANDED OPERATIONS	REDUCED OPERATIONS	GREENER
Tritium	21	21	21	21
Americium-241	6.60×10^{-7}	6.60×10^{-7}	6.60×10^{-7}	6.60×10^{-7}
Plutonium-238	4.80×10^{-6}	4.80×10^{-6}	4.80×10^{-6}	4.80×10^{-6}
Plutonium-239	6.80×10^{-7}	6.80×10^{-7}	6.80×10^{-7}	6.80×10^{-7}
Uranium-234	8.00×10^{-6}	8.00×10^{-6}	8.00×10^{-6}	8.00×10^{-6}
Uranium-235	4.10×10^{-7}	4.10×10^{-7}	4.10×10^{-7}	4.10×10^{-7}
Uranium-238	4.00×10^{-6}	4.00×10^{-6}	4.00×10^{-6}	4.00×10^{-6}

Notes:

^a No change in emissions is expected among the SWEIS alternatives. These emissions were back-calculated using the CAP-88 model and are conservatively based on the average, plus two standard deviations of nearby environmental concentration measurements.

^b No stack emissions. This is an area source. An area of 5,000 square meters was used. This value was used based on information obtained from LANL personnel regarding the area of waste disposal.

TABLE B.1.1.4-13.—Radiological Air Emissions from TA-53 (LANSCE—ES-2 Stack)^{a,b}

RADIONUCLIDE	ALTERNATIVE (CURIES PER YEAR) ^c			
	NO ACTION	EXPANDED OPERATIONS	REDUCED OPERATIONS	GREENER
Argon-41	55.2	69.0	27.6	69.0
Carbon-10	2.12	2.65	1.06	2.65
Carbon-11	2,240	2,790	1,120	2,790
Nitrogen-13	348	434	174	434
Oxygen-14	5.29	6.61	2.65	6.61
Oxygen-15	464	581	233	581

Notes:

^a TA-53 emissions were divided into five sources: ES-2 stack emissions, ES-3 stack emissions, LEDA emissions, IPF-2 emissions, and diffuse emissions.

^b ES-2 stack emissions: evacuation from the Manuel Lujan Neutron Scattering Center (MLNSC), Weapons Neutron Research (WNR), and Line D-South. Parameters are: Height = 13 meters (m), Diameter = 0.9 m, Exit Velocity = 7 meters per second.

^c Increased by factor of 200/70 to account for increased beam current.

TABLE B.1.1.4-14.—Radiological Air Emissions from TA-53 (LANSCE—ES-3 Stack)^{a,b}

RADIONUCLIDE	ALTERNATIVE (CURIES PER YEAR)			
	NO ACTION	EXPANDED OPERATIONS	REDUCED OPERATIONS	GREENER
Argon-41	345	862	172	862
Carbon-11	3,100	7,760	1,550	7,760

Notes:

^a TA-53 emissions were divided into five sources: ES-2 stack emissions, ES-3 stack emissions, LEDA emissions, IPF-2 emissions, and diffuse emissions.

^b ES-3 stack emissions: evacuation from experimental areas A, B, and C, and associated lines B and C tunnels. Parameters are: Height = 30.5 meters (m), Diameter = 0.9 m, Exit Velocity = 12.5 meters per second.

TABLE B.1.1.4-15.—Radiological Air Emissions from TA-53 (LANSCE—LEDA)^{a,b}

RADIONUCLIDE	ALTERNATIVE (CURIES PER YEAR)			
	NO ACTION	EXPANDED OPERATIONS	REDUCED OPERATIONS	GREENER
Argon-41		2.29	2.29	2.29
Nitrogen-13	0.163	0.163	0.163	0.163
Nitrogen-16	0.0285	0.0285	0.0285	0.0285
Oxygen-15	0.00177	0.00177	0.00177	0.00177
Oxygen-19	0.00216	0.00216	0.00216	0.00216
Sulfur-37	0.00181	0.00181	0.00181	0.00181
Chlorine-39	0.00047	0.00047	0.00047	0.00047
Chlorine-40	0.00219	0.00219	0.00219	0.00219
Krypton-83m	0.00221	0.00221	0.00221	0.00221
Others	0.00111	0.00111	0.00111	0.00111

Notes:

^a TA-53 emissions were divided into five sources: ES-2 stack emissions, ES-3 stack emissions, LEDA emissions, IPF-2 emissions, and diffuse emissions.

^b LEDA emissions: evacuation from the Low Energy Demonstration Accelerator. Emissions were assumed to exit through the ES-3 stack with parameters: Height = 30.5 meters (m), Diameter = 0.9 m, Exit Velocity = 12.5 meters per second.

TABLE B.1.1.4-16.—Radiological Air Emissions from TA-53 (LANSCE—IPF-2)^{a,b}

RADIONUCLIDE	ALTERNATIVE (CURIES PER YEAR)			
	NO ACTION	EXPANDED OPERATIONS	REDUCED OPERATIONS	GREENER
Carbon-11	70	87.5	35	87.5
Nitrogen-13	80	100	40	100
Oxygen-15	20	25	10	25

Notes:

^a TA-53 emissions were divided into five sources: ES-2 stack emissions, ES-3 stack emissions, LEDA emissions, IPF-2 emissions, and diffuse emissions.

^b IPF-2 emissions: evacuation from the Isotope Production Facility 2. Emissions were assumed to exit through the ES-3 stack with parameters: Height = 30.5 meters (m), Diameter = 0.9 m, Exit Velocity = 12.5 meters per second.

TABLE B.1.1.4-17.—Radiological Air Emissions from TA-53 (LANSCE—Diffuse)^{a,b}

RADIONUCLIDE	ALTERNATIVE (CURIES PER YEAR)			
	NO ACTION	EXPANDED OPERATIONS	REDUCED OPERATIONS	GREENER
Argon-41	2.56	3.2	1.28	3.2
Carbon-11	61.44	76.8	30.72	76.8

Notes:

^a TA-53 emissions were divided into five sources: ES-2 stack emissions, ES-3 stack emissions, LEDA emissions, IPF-2 emissions, and diffuse emissions.

^b Diffuse emissions: escape from the area around the high intensity beam line (Line A). No stack emissions.

- All uranium-238 emissions were assumed to be in equilibrium with its decay daughters, thorium-234 and protactinium-234m.
- Unidentified mixed fission products (MFPs) or MAPs are modeled as strontium-90/yttrium-90 in equilibrium. This was done for some unidentified MAPs from the Low Energy Demonstration Accelerator (LEDA) emissions at the LANSCE and for some MAPs and MFPs from TA-48.
- Tritium can exist in gaseous (elemental tritium) or water vapor (tritium oxide) forms. The oxide form is used in CAP-88 to ensure conservative results because it produces a higher dose. All tritium emissions were modeled as oxides from TA-16 and TA-21 (the tritium facilities).

Source Parameters

LANL emission sources include individual stacks and large area (diffuse) sources. For stack emissions, the actual stack heights, diameters, and exit velocities were used. These stack parameters are reflected in Tables B.1.1.4-1 through B.1.1.4-17.

The sizes of area sources were calculated based on site information. Because the sizes of area sources could not always be precisely determined, a sensitivity analysis was performed using various area sizes. This analysis was performed by changing the sizes of the areas modeled while fixing all other parameters. Areas of 1,075, 10,750, and 107,500 square feet (100, 1,000, and 10,000 square meters) were used in separate model runs

for the same case, and the results in all three runs were exactly the same. The conclusion was that the resultant dose was independent of the size of the area source if the radionuclide emission rates was the same due to the distance of the modeled MEI or member of the population from the area source. Despite this sensitivity analysis, the best estimate of an area’s size was used in all cases for the actual modeling.

Agricultural Data

Radionuclides emitted to the air and subsequently ingested with food crops is one pathway of exposure used by CAP-88. The immediate region surrounding the LANL site does not have any major agricultural production activities; however, the agricultural data used in the modeling effort are reflected in Table B.1.1.4-18 (EPA 1992a).

These agricultural data were provided in the CAP-88 database for the State of New Mexico. Using these parameters may have resulted in an overestimate of the dose to individuals living in close proximity to the LANL site.

Meteorological Data

Meteorological data are used in conjunction with the CAP-88 model to estimate air dispersion of emitted nuclides. There were four meteorological towers distributed over the LANL sites used for this purpose. The meteorological data used for each tower were the average of 3 years of actual meteorological data. The tower nearest to the modeled facility was used for input data, as reflected below.

TABLE B.1.1.4-18.—*Fraction of Agricultural Products Produced in the Home, Assessment Area, and Imported*

	VEGETABLE	MILK	MEAT
Fraction Home Produced	0.7	0.399	0.442
Fraction Assessment Area Produced	0.3	0.601	0.558
Fraction Imported	0	0	0

- *TA-6 Tower*—Used for modeling emissions from TA-3, TA-16, TA-48, and TA-55
- *TA-49 Tower*—Used for modeling emissions from TA-15 and TA-36
- *TA-53 Tower*—Used for modeling emissions from TA-21 and TA-53
- *TA-54 Tower*—Used for modeling emissions from TA-18 and TA-54

The use of 3 years' data for modeling purposes is due to the fact that these towers have existed in these locations for that period of time. The use of average meteorological data over this period is expected to reflect future conditions more accurately than data from any individual year.

Other meteorological data needed as input to CAP-88 are:

- Annual precipitation = 19 inches (48 centimeters) per year (Bowen 1990)
- Annual ambient temperature = 48°F (8.8°C) (Bowen 1990)
- Height of lid = 5,000 feet (1,525 meters)
The lid height (vertical extent of mixing of air emissions) was obtained from the weather center in Albuquerque and was verified by the National Oceanographic and Atmospheric Administration.

Distances Between Emission Points and Receptors

The distances between the emission sources and the specific location modeled must be introduced as input parameters for CAP-88 to calculate the nuclide concentration and subsequent doses at that location. Map coordinates for each source at LANL and each receptor location were determined using large maps and Geographic Information System (GIS) graphics. The distances were then calculated using these coordinate points. The distances and direction between each modeled facility and the facility-specific MEI location are listed in Table B.1.1.4–19.

Population Data

Data regarding the population distribution within a 50-mile (80-kilometer) radius around LANL are needed by CAP-88 for the calculation of the collective population dose. LANL has been using a population data file that was prepared based on the 1990 Census (DOC 1991). A new population data file was prepared by the University of Nevada (UN) in 1995, using data from the New Mexico Bureau of Business and Economic Research (BBER 1995). The UN data file was used for all CAP-88 population runs, consistent with the socioeconomic data used for the SWEIS. There are no significant differences between the LANL data file and the UN data file.

The input parameters described above were input into the CAP-88 model to generate the estimated radionuclide concentrations and resulting radiation dose equivalents. Various receptors were modeled as bounding estimates. These receptors are discussed individually below.

B.1.1.5 Facility-Specific Maximally Exposed Individual Doses

CAP-88 runs were made using each modeled facility's air emissions to determine the CEDE at various locations. The results were examined, and a single point at the LANL boundary where the highest dose occurs was identified. The distance and direction to these points were determined. These points are the locations of the facility-specific MEIs. The distances and directions of all facility-specific MEIs are listed in Table B.1.1.5–1. The distances and directions for all MEIs, with respect to all modeled facilities, are presented in Table B.1.1.4–19, as noted above. The dose commitment from all facility emissions were then calculated for each FS MEI location and summed to provide the total dose at that location. The contribution from each modeled

TABLE B.1.1.4-19.—Distances (Meters) and Directions Between the Modeled Facilities and the Facility-Specific MEI

MODELED FACILITY	MEI		TA-3-29 CMR; TA-3-66 SIGMA	TA-48 RADIO-CHEMISTRY LAB; TA-55 PLUTONIUM FACILITY	TA-3-102 MAIN SHOPS	TA-16 TRITIUM FACILITY	TA-18 PAJARITO SITE	TA-21 TRITIUM FACILITY	TA-53 LANSCE	TA-54 AREA G ^a	TA-54 AREA G ^b	TA-15/36 FIRING SITES	TA-11 HIGH EXPLOSIVES TESTING
	NORTHING	EASTING											
TA-3-29 (CMR)	1772369	1619014	1,619,600	1,624,900	1,618,100	1,611,100	1,636,900	1,634,200	1,638,700	1,645,600	1,649,200	1,632,900	1,615,100
			3,575	5,955	3,265	15,960	19,785	15,455	19,765	29,940	34,975	15,110	15,420
TA-3-66 (Sigma)	1772352	1619258	N	E	NNW	SSW	ESE	E	E	ESE	ESE	ESE	SSW
			3,560	5,725	3,345	16,075	19,570	15,205	19,520	29,710	34,760	14,880	15,520
TA-3-102 (Shops)	1772127	1618300	N	E	NW	SW	ESE	E	E	ESE	ESE	ESE	SSW
			3,990	6,710	3,380	15,420	20,340	16,190	20,490	30,460	35,480	15,680	15,075
TA-16 (Tritium Facility)	1760866	1609447	NNE	E	NW	SW	ESE	E	E	ESE	ESE	ESE	SSW
			18,145	19,835	16,995	2,885	27,625	28,610	32,105	36,220	40,225	24,100	6,625
TA-18 (Pajarito Site)	1761900	1634900	NE	NE	NNE	SSE	ESE	ENE	ENE	ESE	ESE	ENE	ESE
			20,735	15,155	21,620	24,050	2,820	13,320	12,780	11,205	16,010	4,920	20,310
TA-21 (Tritium Facility)	1774175	1633991	NW	NW	NW	W	NE	N	NNE	ESE	ESE	NNW	W
			14,500	9,135	15,940	27,730	10,675	1,050	4,705	19,420	24,700	7,855	25,255
TA-48 (Radiochemistry Laboratory)	1770639	1623684	W	W	W	WSW	SSE	N	E	SE	SE	S	SW
			6,660	2,920	7,395	17,480	14,825	11,465	15,400	24,995	30,080	10,135	15,775
TA-53 (LANSCE)	1771546	1638133	NW	NNE	NW	SW	ESE	ENE	E	ESE	SE	ESE	SW
			19,025	13,350	20,420	30,010	7,740	5,365	2,625	14,940	20,155	7,345	27,025
TA-54 (Area G)	1757700	1644800	WNW	W	WNW	WSW	SSE	NW	NNE	SSE	SSE	SW	WSW
			31,080	25,270	32,080						1,195		
TA-55 (Plutonium Facility)	1769609	1624860	NW	NW	NW	W	NW	NNW	NNW	NE	SE	NW	W
			8,200	3,690	33,700	17,680	13,315	10,890	14,545	23,470	28,535	8,660	15,630
TA-15/36 (Firing Sites)	1759700	1629700	NW	N	NW	SW	ESE	ENE	ENE	ESE	ESE	ESE	SW
			19,090	14,415	19,600	18,630	8,330	16,140	16,975	15,940	20,125	7,415	14,775
			NNW	NNW	NW	W	ENE	ENE	NE	ESE	ESE	NE	W

TABLE B.1.1.4-19.—Distances (Meters) and Directions Between the Modeled Facilities and the Facility-Specific MEI-Continued

MODELED FACILITY	MEI		TA-3-29 CMR;	TA-48 RADIO- CHEMISTRY LAB; TA-55 PLUTONIUM FACILITY	TA-3-102 MAIN SHOPS	TA-16 TRITIUM FACILITY	TA-18 PAJARITO SITE	TA-21 TRITIUM FACILITY	TA-53 LANSCÉ	TA-54 AREA G ¹	TA-54 AREA G ²	TA-15/36 FIRING SITES	TA-11 HIGH EXPLOSIVES TESTING
	1761700	1615300	14,825	15,055	14,070	5,280	21,715	23,220	26,470	30,455	34,605	18,205	4,300
			NNW	NE	NNW	SW	E	NE	ENE	ESE	ESE	ENE	S
TA-11 (High Explosives Testing)			NNW	NE	NNW	SW	E	NE	ENE	ESE	ESE	ENE	S

Note: This table identifies the distance and direction from each modeled facility to each facility's MEI. These values were used as input parameters for CAP-88 model runs and to calculate the dose contribution from each modeled facility to each MEI. As an example, the LANSCÉ MEI is located about 4,705 feet east of TA-21. Northings and Eastings in the first two rows pertain to the MEIs; Northings and Eastings in the columns pertain to the modeled facilities.

^a Hypothetical site at boundary of LANL and San Ildefonso Pueblo.

^b Actual MEI in the town of White Rock.

TABLE B.1.1.5-1.—Distance and Directions to Facility-Specific Maximally Exposed Individuals

FACILITY	MEI DISTANCE FEET (METERS)	DIRECTION
TA-3-29 (CMR)	3,575 (1,090)	North
TA-3-66 (Sigma Building)	3,560 (1,085)	North
TA-3-102 (Machine Shops)	3,380 (1,030)	North
TA-11 (High Explosives Testing)	4,300 (1,310)	South
TA-15/36 (Firing Sites)	7,415 (2,260)	Northeast
TA-16 (WETF)	2,885 (880)	South-Southeast
TA-18 (Pajarito Site: LACEF)	2,820 (860)	Northeast
TA-21 (TSTA and TSFF)	1,050 (320)	North
TA-48 (Radiochemistry Laboratory)	2,920 (890)	North-Northeast
TA-53 (LANSCE)	2,625 (800)	North-Northeast
TA-54 (Area G)	1,195 (365)	Northeast—LANL Boundary
	5,330 (1,625)	Southeast—White Rock
TA-55 (Plutonium Facility)	3,690 (1,125)	North

Note: This table lists the facility-specific MEI location from each modeled facility. These data are also contained in Table B.1.1.4-19.

facility to each MEI was calculated for each of the four SWEIS alternatives.

The MEI locations do not necessarily represent actual residences or individuals. They are merely points at the LANL boundary where the highest potential dose occurs. Some points at the LANL boundary do have residences close to them. This is especially true for those TAs located in the northern part of the LANL site, such as TA-3 and TA-53.

Two FS MEI locations were considered for Area G because it borders San Ildefonso Pueblo land. The first location is at the LANL boundary, 1,197 feet (365 meters) northeast of Area G next to San Ildefonso land. No one currently lives in that location. The second location is in the town of White Rock, approximately 5,331 feet (1,625 meters) southeast of Area G.

Some modeled facilities share the same MEI location. TA-3-29 (CMR) and TA-3-66 (Sigma) share the same MEI location, as do

TA-48 (Radiochemistry Facility) and TA-55 (Plutonium Facility).

B.1.1.6 LANL Site-Wide Maximally Exposed Individual Dose

The LANL site-wide MEI dose was determined by examining the total dose to each FS MEI. The FS MEI with the highest total dose is considered to be the LANL site-wide MEI for that alternative. For every FS MEI location, the total dose is the dose contributed by that specific facility, plus any doses contributed by other modeled facilities.

B.1.1.7 Population Dose

The dose to the population living within a 50-mile (80-kilometer) radius from LANL was calculated by CAP-88 using the UN population data prepared from BBER data (BBER 1995). For each modeled facility, a population run was made for each of the four alternatives. The

results from each modeled facility for each alternative were added to obtain the total population dose for that alternative.

B.1.1.8 *Isodose Maps*

Isodose maps (maps showing lines of equal dose) were generated for the region within a 50-mile (80-kilometer) radius from LANL. The isodose maps show contour lines representing the annual individual dose at the points where the lines pass through. Four CAP-88 runs were made for each emission source for each alternative in order to generate data points sufficient to create the isodose maps. The following distances (in meters) were introduced as an input to CAP-88 runs to generate these maps:

- *Run No. 1*—300, 400, 500, 600, 700, 800, 900, 1,000, 1,100, 1,200, 1,300, 1,400, 1,500, 1,600, 1,800, 2,000, 2,200, 2,400, 2,600, and 2,800
- *Run No. 2*—3,000, 3,200, 3,400, 3,600, 3,800, 4,000, 4,200, 4,400, 4,600, 4,800, 5,000, 5,500, 6,000, 6,500, 7,000, 7,500, 8,000, 8,500, 9,000, and 9,500
- *Run No. 3*—10,000, 11,000, 12,000, 13,000, 14,000, 15,000, 16,000, 17,000, 18,000, 19,000, 20,000, 22,000, 24,000, 26,000, 28,000, 30,000, 32,000, 34,000, 36,000, and 38,000
- *Run No. 4*—40,000, 42,000, 44,000, 46,000, 48,000, 50,000, 52,000, 54,000, 56,000, 58,000, 60,000, 62,000, 64,000, 66,000, 68,000, 70,000, 72,500, 75,000, 77,500, and 80,000

Dose calculations were made at each distance in 16 directions around the emission source for each alternative. The results were then used to generate the isodose maps using GIS overlays. The results of the runs for all emission sources were summed to obtain the isodose maps for all of LANL operations. Two sets of isodose maps were generated. The first set of four maps (one map per alternative) covers the region around

LANL with an average individual dose higher than 1 millirem per year. The second set of four maps (one map per alternative) covers the rest of the 50-mile (80-kilometer) region where average individual doses were less than 1 millirem per year.

B.1.2 **Results of Consequence Analyses**

B.1.2.1 *Doses to Facility-Specific Maximally Exposed Individuals*

For each FS MEI, the total dose at the MEI location was calculated by adding the contributions from each modeled facility. The highest dose for an alternative is the LANL MEI for that alternative.

The contribution of each modeled facility to the FS MEIs for the four SWEIS alternatives are included in Tables B.1.2.1-1 through B.1.2.1-4. The totals shown on these tables are summarized in Table B.1.2.1-5.

B.1.2.2 *Dose to the LANL Site-Wide Maximally Exposed Individual*

As noted above, the LANL site-wide MEI is determined by identifying the FS MEI with the highest total dose. The location of and modeled dose to the LANL site-wide MEI for each alternative is summarized in Table B.1.2.2-1.

The NESHAP requires that the dose resulting from air emissions to the LANL MEI not exceed 10 millirem per year. As shown in Table B.1.2.2-1, this regulatory limit would not be exceeded under any of the SWEIS alternatives. In fact, the highest MEI dose was 5.44 millirem per year for the Expanded Operations Alternative, which is 54.4 percent of the

TABLE B.1.2.1-1.—Doses to Facility-Specific MEIs from LANL Operations for the No Action Alternative (millirems per year)

MEI SOURCE	TA-3-29/ TA-3-66 CMR AND SIGMA	TA-3-102 SHOPS	TA-11 HIGH EXPLOSIVES	TA-16 TRITIUM FACILITY	TA-18 PAJARITO SITE	TA-21 TRITIUM FACILITY	TA-48/55 RADIO- CHEMISTRY LABORATORY AND PLUTONIUM FACILITY	TA-53 LANSCÉ ^a	TA-54 AREA G (LANL BOUNDARY)	TA-54 AREA G (WHITE ROCK)	TA-15/36 FIRING SITES
TA-3-29 (CMR)	6.43E-02	4.67E-02	4.16E-03	3.93E-03	1.12E-02	1.48E-02	5.51E-02	1.12E-02	1.12E-03	5.12E-03	1.60E-02
TA-3-66 (Sigma)	3.41E-02	2.29E-02	2.30E-03	2.14E-03	6.62E-03	8.42E-03	2.96E-02	6.64E-03	3.74E-03	3.08E-03	9.28E-03
TA-3-102 (Shops)	2.93E-03	1.98E-03	1.72E-04	1.59E-04	4.79E-04	6.35E-04	3.04E-03	4.83E-04	2.62E-04	2.11E-04	6.98E-04
TA-11 (High Explosives Testing)	3.14E-06	4.56E-06	3.41E-05	1.26E-05	3.02E-06	2.25E-06	4.15E-06	1.90E-06	1.87E-06	1.38E-06	3.63E-06
TA-15/36 (Firing Sites)	1.04E-01	7.71E-02	1.21E-01	8.40E-02	1.05E+00	3.27E-01	1.62E-01	3.17E-01	4.24E-01	2.40E-01	1.16E+00
TA-16 (Tritium Facility)	1.68E-02	1.78E-02	8.18E-02	1.44E-01	1.32E-02	1.19E-02	1.54E-02	8.08E-03	7.01E-03	5.88E-03	1.41E-02
TA-18 (Pajarito Site)	3.50E-04	3.39E-04	5.41E-04	3.04E-04	8.63E-02	2.76E-03	6.90E-04	5.49E-03	1.42E-02	7.98E-03	7.30E-03
TA-21 (Tritium Facility)	4.72E-02	4.47E-02	4.04E-02	3.62E-02	1.07E-01	6.50E-01	1.56E-01	3.66E-01	5.33E-02	4.43E-02	2.53E-01
TA-48 (Gram calculation)	1.88E-04	1.58E-04	5.51E-05	4.25E-05	2.20E-04	2.06E-04	1.01E-03	1.73E-04	1.19E-04	8.99E-05	3.44E-04
TA-48 (LANL calculation)	1.53E-01	1.17E-01	5.05E-02	3.71E-02	2.20E-01	2.12E-01	1.22E+00	1.66E-01	1.02E-01	7.67E-02	3.60E-01
TA-53 Diffuse	7.27E-05	6.47E-05	5.06E-05	3.28E-05	2.84E-03	2.52E-03	2.43E-04	4.48E-02	4.88E-04	2.59E-04	2.29E-03
ES-2	2.53E-03	2.21E-03	1.75E-03	1.10E-03	1.07E-01	8.55E-02	8.71E-03	1.34E+00	1.87E-02	9.78E-03	8.17E-02
ES-3	4.61E-03	4.25E-03	3.54E-03	2.38E-03	1.20E-01	8.63E-02	1.40E-02	7.50E-01	2.75E-02	1.56E-02	9.46E-02
IPF-2	8.02E-05	7.12E-05	5.65E-05	3.47E-05	3.55E-03	2.52E-03	2.80E-04	3.00E-02	6.63E-04	3.52E-04	2.69E-03
LEDA	1.27E-04	1.28E-04	9.73E-05	7.32E-05	6.04E-04	4.41E-04	2.06E-04	2.12E-03	2.63E-04	1.95E-04	5.29E-04
TA-54 (Area G)	4.36E-04	4.00E-04	5.40E-04	2.11E-04	3.11E-03	6.04E-04	5.37E-04	6.46E-04	8.90E-02	2.21E-02	6.52E-04
TA-55 (Plutonium Facility)	1.45E-01	1.32E-01	2.69E-02	2.51E-02	9.05E-02	9.54E-02	3.37E-01	6.17E-02	5.18E-02	4.27E-02	2.59E-01
Total	0.58	0.47	0.33	0.34	1.82	1.50	2.00	3.11	0.08	0.47	2.26

^a This is also the LANL site-wide MEI because it has the highest dose among the facility-specific MEIs.

TABLE B.1.2.1-2.—Doses to Facility-Specific MEIs from LANL Operations for the Expanded Operations Alternative (millirems per year)

MEI SOURCE	TA-3-29/ TA-3-66 CMR AND SIGMA	TA-3-102 SHOPS	TA-11 HIGH EXPLOSIVES	TA-16 TRITIUM FACILITY	TA-18 PAJARITO SITE	TA-21 TRITIUM FACILITY	TA-48/55 RADIO- CHEMISTRY LABORATORY AND PLUTONIUM FACILITY	TA-53 LANSCÉ ^a	TA-54 AREA G (LANL BOUNDARY)	TA-54 AREA G (WHITE ROCK)	TA-15/36 FIRING SITES
TA-3-29 (CMR)	4.95E-01	3.86E-01	4.13E-02	3.98E-02	9.00E-02	1.11E-01	4.22E-01	9.00E-02	5.70E-02	4.38E-02	1.19E-01
TA-3-66 (Sigma)	1.02E-01	6.87E-02	6.90E-03	6.43E-03	1.99E-02	2.53E-02	8.89E-02	1.99E-02	1.12E-02	9.23E-03	2.78E-02
TA-3-102 (Shops)	8.36E-03	9.33E-03	5.97E-04	5.14E-04	1.35E-03	1.76E-03	6.93E-03	1.35E-03	7.60E-04	6.14E-04	1.92E-03
TA-11 (High Explosives Testing)	1.03E-05	1.14E-05	8.52E-05	3.16E-05	7.54E-06	5.62E-06	1.04E-05	4.76E-06	4.68E-06	3.46E-06	9.08E-06
TA-15/36 (Firing Sites)	3.13E-01	2.31E-01	3.64E-01	2.52E-01	3.15E+00	9.81E-01	4.86E-01	9.52E-01	1.27E+00	7.20E-01	3.48E+00
TA-16 (Tritium Facility)	3.36E-02	3.56E-02	1.64E-01	2.87E-01	2.65E-02	2.38E-02	3.07E-02	1.62E-02	1.40E-02	1.18E-02	2.81E-02
TA-18 (Pajarito Site)	4.37E-04	4.24E-04	6.76E-04	3.80E-04	1.08E-01	3.45E-03	8.63E-04	6.86E-03	1.77E-02	9.98E-03	9.13E-03
TA-21 (Tritium Facility)	4.72E-02	4.47E-02	4.04E-02	3.62E-02	1.07E-01	6.50E-01	1.56E-01	3.66E-01	5.33E-02	4.43E-02	2.53E-01
TA-48 (GRAM calculation)	3.23E-04	2.66E-04	9.75E-05	7.39E-05	4.09E-04	3.88E-04	1.83E-03	3.19E-04	2.18E-04	1.64E-04	6.33E-04
TA-48 (LANL calculation)	3.07E-01	2.33E-01	1.01E-01	7.42E-02	4.40E-01	4.24E-01	2.43E+00	3.32E-01	2.03E-01	1.53E-01	7.21E-01
TA-53 Diffuse	9.08E-05	8.09E-05	6.33E-05	4.10E-05	3.55E-03	3.15E-03	3.04E-04	5.60E-02	6.10E-04	3.24E-04	2.86E-03
ES-2	3.16E-03	2.76E-03	2.19E-03	1.37E-03	1.33E-01	1.07E-01	1.09E-02	1.68E+00	2.33E-02	1.22E-02	1.02E-01
ES-3	1.15E-02	1.06E-02	8.85E-03	5.95E-03	2.99E-01	2.16E-01	3.49E-02	1.88E+00	6.89E-02	3.89E-02	2.37E-01
IPF-2	1.00E-04	8.90E-05	7.07E-05	4.34E-05	4.44E-03	3.15E-03	3.50E-04	3.75E-02	8.28E-04	4.40E-04	3.36E-03
LEDA	1.27E-04	1.28E-04	9.73E-05	7.32E-05	6.04E-04	4.41E-04	2.06E-04	2.12E-03	2.63E-04	1.95E-04	5.29E-04
TA-54 (Area G)	4.36E-04	4.00E-04	5.40E-04	2.11E-04	3.11E-03	6.04E-04	5.37E-04	6.46E-04	8.90E-02	2.21E-02	6.52E-04
TA-55 (Plutonium Facility)	1.48E-02	1.37E-02	2.88E-03	2.68E-03	1.01E-02	1.05E-02	3.67E-02	6.90E-03	5.74E-03	4.67E-03	2.80E-02
Total	1.32	1.02	0.73	0.70	4.39	2.55	3.67	5.44	1.81	1.07	4.99

^a This is also the LANL site-wide MEI because it has the highest dose among the facility-specific MEIs.

TABLE B.1.2.1-3.—Doses to Facility-Specific MEIs from LANL Operations for the Reduced Operations Alternative (millirems per year)

MEI SOURCE	TA-3-29/ TA-3-66 CMR AND SIGMA	TA-3-102 SHOPS	TA-11 HIGH EXPLOSIVES	TA-16 TRITIUM FACILITY	TA-18 PAJARITO SITE	TA-21 TRITIUM FACILITY	TA-48/55 RADIO- CHEMISTRY LABORATORY AND PLUTONIUM FACILITY	TA-53 LANSCÉ BOUNDARY	TA-54 AREA G (WHITE ROCK)	TA-15/36 FIRING SITES ^a
TA-3-29 (CMR)	5.79E-02	4.20E-02	3.75E-03	3.54E-03	1.00E-02	1.33E-02	4.96E-02	1.01E-02	5.68E-03	1.44E-02
TA-3-66 (Sigma)	3.41E-02	2.29E-02	2.30E-03	2.14E-03	6.62E-03	8.42E-03	2.96E-02	6.64E-03	3.74E-03	9.28E-03
TA-3-102 (Shops)	2.79E-03	3.11E-03	1.99E-04	1.71E-04	4.48E-04	5.86E-04	2.31E-03	4.50E-04	2.53E-04	6.40E-04
TA-11 (High Explosives Testing)	2.48E-06	2.74E-06	2.04E-05	7.58E-06	1.81E-06	1.35E-06	2.49E-06	1.14E-06	8.30E-07	2.18E-06
TA-15/36 (Firing Sites)	1.04E-01	7.71E-02	1.21E-01	8.40E-02	1.05E+00	3.27E-01	1.62E-01	3.17E-01	4.24E-01	116E+00
TA-16 (Tritium Facility)	1.97E-02	2.12E-02	1.08E-01	6.91E-02	1.60E-02	1.37E-02	1.95E-02	1.27E-02	1.18E-02	1.79E-02
TA-18 (Pajarito Site)	3.50E-04	3.39E-04	5.41E-04	3.04E-04	8.63E-02	2.76E-03	6.90E-04	5.49E-03	1.42E-02	7.98E-03
TA-21 (Tritium Facility)	4.72E-02	4.47E-02	4.04E-02	3.62E-02	1.07E-01	6.50E-01	1.56E-01	3.66E-01	5.33E-02	2.53E-01
TA-48 (GRAM calculation)	1.56E-04	1.28E-04	4.72E-05	3.55E-05	1.98E-04	1.86E-04	8.97E-04	1.54E-04	1.06E-04	3.06E-04
TA-48 (LANL calculation)	7.66E-02	5.83E-02	2.53E-02	1.85E-02	1.10E-01	1.06E-01	6.08E-01	8.31E-02	5.08E-02	1.80E-01
TA-53 Diffuse	3.63E-05	3.24E-05	2.53E-05	1.64E-05	1.42E-03	1.26E-03	1.22E-04	2.24E-02	2.44E-04	1.14E-03
ES-2	1.23E-03	1.08E-03	8.52E-04	5.32E-04	5.18E-02	4.15E-02	4.23E-03	6.52E-01	9.07E-03	3.98E-02
ES-3	2.31E-03	2.12E-03	1.77E-03	1.19E-03	5.99E-02	4.32E-02	6.98E-03	3.75E-01	1.38E-02	4.73E-02
IPF-2	4.01E-05	3.56E-05	2.83E-05	1.74E-05	1.78E-03	1.26E-03	1.40E-04	1.50E-02	3.31E-04	1.34E-03
LEDA	1.27E-04	1.28E-04	9.73E-05	7.32E-05	6.04E-04	4.41E-04	2.06E-04	2.12E-03	2.63E-04	5.29E-04
TA-54 (Area G)	4.36E-04	4.00E-04	5.40E-04	2.11E-04	3.11E-03	6.04E-04	5.37E-04	6.46E-04	8.90E-02	6.52E-04
TA-55 (Plutonium Facility)	1.46E-02	1.37E-02	2.73E-03	2.56E-03	9.41E-03	9.80E-03	3.47E-02	6.39E-03	5.36E-03	2.60E-02
Total	0.36	0.29	0.31	0.22	1.51	1.22	1.08	1.88	0.68	1.76

Note: 6.43E-02 = 6.43 x 10⁻²

^aThis is also the LANL site-wide MEI because it has the highest dose among the facility-specific MEIs.

TABLE B.1.2.1-4.—Doses to Facility-Specific MEIs from LANL Operations for the Greener Alternative (millirems per year)

MEI SOURCE	TA-3-29/ TA-3-66 CMR AND SIGMA	TA-3-102 SHOPS	TA-11 HIGH EXPLOSIVES	TA-16 TRITIUM FACILITY	TA-18 PAJARITO SITE	TA-21 TRITIUM FACILITY	TA-48/55 RADIO- CHEMISTRY LABORATORY AND PLUTONIUM FACILITY	TA-53 LANSCÉ ^a	TA-54 AREA G (LANL BOUNDARY)	TA-54 AREA G (WHITE ROCK)	TA-15/36 FIRING SITES
TA-3-29 (CMR)	6.43E-02	4.67E-02	4.16E-03	3.93E-03	1.12E-02	1.48E-02	5.51E-02	1.12E-02	6.31E-03	5.12E-03	1.60E-02
TA-3-66 (Sigma)	3.41E-02	2.29E-02	2.30E-03	2.14E-03	6.62E-03	8.42E-03	2.96E-02	6.64E-03	3.74E-03	3.08E-03	9.28E-03
TA-3-102 (Shops)	2.79E-03	3.11E-03	1.99E-04	1.71E-04	4.48E-04	5.86E-04	2.31E-03	4.50E-04	2.53E-04	2.05E-04	6.40E-04
TA-11 (High Explosives Testing)	2.48E-06	2.74E-06	2.04E-05	7.58E-06	1.81E-06	1.35E-06	2.49E-06	1.14E-06	1.12E-06	8.30E-07	2.18E-06
TA-15/36 (Firing Sites)	1.04E-01	7.71E-02	1.21E-01	8.40E-02	1.05E+00	3.27E-01	1.62E-01	3.17E-01	4.24E-01	2.40E-01	1.16E+00
TA-16 (Tritium Facility)	1.68E-02	1.78E-02	8.18E-02	1.44E-01	1.32E-02	1.19E-02	1.54E-02	8.08E-03	7.01E-03	5.88E-03	1.41E-02
TA-18 (Pajarito Site)	3.50E-04	3.39E-04	5.41E-04	3.04E-04	8.63E-02	2.76E-03	6.90E-04	5.49E-03	1.42E-02	7.98E-03	7.30E-03
TA-21 (Tritium Facility)	4.72E-02	4.47E-02	4.04E-02	3.62E-02	1.07E-01	6.50E-01	1.56E-01	3.66E-01	5.33E-02	4.43E-02	2.53E-01
TA-48 (GRAM calculation)	3.13E-04	2.56E-04	9.63E-05	7.22E-05	4.05E-04	3.78E-04	1.81E-03	3.12E-04	2.12E-04	1.62E-04	6.22E-04
TA-48 (LANL calculation)	1.53E-01	1.17E-01	5.05E-02	3.71E-02	2.20E-01	2.12E-01	1.22E+00	1.66E-01	1.02E-01	7.67E-02	3.60E-01
TA-53 Diffuse	9.08E-05	8.09E-05	6.33E-05	4.10E-05	3.55E-03	3.15E-03	3.04E-04	5.60E-02	6.10E-04	3.24E-04	2.86E-03
ES-2	3.16E-03	2.76E-03	2.19E-03	1.37E-03	1.33E-01	1.07E-01	1.09E-02	1.68E+00	2.33E-02	1.22E-02	1.02E-01
ES-3	1.15E-02	1.06E-02	8.85E-03	5.95E-03	2.99E-01	2.16E-01	3.49E-02	1.88E+00	6.89E-02	3.89E-02	2.37E-01
IPF-2	1.00E-04	8.90E-05	7.07E-05	4.34E-05	4.44E03	3.15E-03	3.50E-04	3.75E-02	8.28E-04	4.40E-04	3.36E-03
LEDA	1.27E-04	1.28E-04	9.73E-05	7.32E-05	6.04E-04	4.41E-04	2.06E-04	2.12E-03	2.63E-04	1.95E-04	5.29E-04
TA-54 (Area G)	4.36E-04	4.00E-04	5.40E-04	2.11E-04	3.11E-03	6.04E-04	5.37E-04	6.46E-04	8.90E-02	2.21E-02	6.52E-04
TA-55 (Plutonium Facility)	1.48E-02	1.37E-02	2.80E-03	2.61E-03	9.74E-03	1.02E-02	3.57E-02	6.64E-03	5.53E-03	4.51E-03	2.70E-02
Total	0.35	0.28	0.31	0.31	1.93	1.54	1.64	4.52	0.79	0.45	2.17

^aThis is also the LANL site-wide MEI because it has the highest dose among the facility-specific MEIs.

TABLE B.1.2.1-5.—Total Doses to the Facility-Specific Maximally Exposed Individuals from LANL Operations (millirems per year)

MEI ALTERNATIVE	TA-3-29 CMR; TA-3-66 SIGMA	TA-3-102 MACHINE SHOPS	TA-11 HIGH EXPLOSIVES TESTING	TA-16 TRITIUM FACILITY	TA-18 PAJARITO SITE	TA-21 TRITIUM FACILITY	TA-48 RADIO-CHEMISTRY LABORATORY TA-55 PLUTONIUM FACILITY	TA-53 LANSCE	TA-54 AREA-G (LANL BOUNDARY)	TA-54 AREA-G (WHITE ROCK)	TA-15/36 FIRING SITES
No Action	0.43	0.34	0.31	0.31	1.73	1.41	1.66	3.11	0.75	0.43	2.26
Expanded Operations	1.32	1.02	0.73	0.70	4.39	2.55	3.67	5.44	1.81	1.07	4.99
Reduced Operations	0.36	0.29	0.31	0.22	1.51	1.22	1.08	1.88	0.68	0.39	1.76
Greener	0.35	0.28	0.31	0.31	1.93	1.54	1.64	4.52	0.79	0.45	2.17

TABLE B.1.2.2-1.—Doses to the LANL Site-Wide Maximally Exposed Individual for Each of the SWEIS Alternatives

ALTERNATIVE	DOSE (mrem/yr)	PERCENT OF NESHAP LIMIT	LOCATION
No Action	3.11	31.1	2,625 feet (800 meters) north-northeast of LANSCE
Expanded Operations	5.44	54.4	2,625 feet (800 meters) north northeast of LANSCE
Reduced Operations	1.88	18.8	2,625 feet (800 meters) north northeast of LANSCE
Greener	4.52	45.2	2,625 feet (800 meters) north-northeast of LANSCE

NESHAP = National Emissions Standards for Hazardous Air Pollutants (40 CFR 61, Subpart H).

regulatory limit. The LANL MEI is the LANSCE FS MEI under all alternatives.

B.1.2.3 Collective Population Dose

The collective dose to the population living within a 50-mile (80-kilometer) radius from LANL has been calculated for emissions from all modeled facilities. The population doses from each source for all four alternatives are presented in Table B.1.2.3–1, while the total collective population doses for the four SWEIS alternatives are presented in Table B.1.2.3–2.

An examination of Table B.1.2.3–1 reveals that most of the population dose comes from emissions from the Firing Sites. The Firing Sites emit long-lived uranium isotopes that can travel long distances without any significant decay. The emissions from LANSCE are mainly short-lived activation products that decay away in a matter of minutes or even seconds. Thus, the LANSCE emissions are important contributors to doses to individuals near LANL, but these emissions are less important to the doses for individuals farther away from LANL.

TABLE B.1.2.3–1.—Collective Population Dose to Residents Within a 50-mile Radius from LANL (person-rem/year)

	NO ACTION	EXPANDED OPERATIONS	REDUCED OPERATIONS	GREENER
CMR	0.195	1.76	0.1755	0.195
Sigma	0.122	0.366	0.122	0.122
TA–11 (HE)	0.0000817	0.000204	0.000049	0.000049
TA–16 (Tritium)	0.276	0.552	0.276	0.276
TA–18	0.0720	0.900	0.0720	0.0720
TA–21 (Tritium)	0.977	0.977	0.977	0.977
Main Shops	0.0101	0.0303	0.0101	0.0101
TA–48 (GRAM)	0.00267	0.00508	0.00244	0.0051
TA–48 (LANL)	3.03	6.06	1.515	3.03
TA–55	0.81	0.0934	0.0845	0.0884
TA–15/–36 (Firing Sites)	7.07	21.21	7.07	7.07
TA–53				
ES–3	0.538	1.345	0.269	1.345
ES–2	0.429	0.536	0.209	0.536
LEDA	0.00327	0.00327	0.00327	0.00327
IPF–2	0.0145	0.0181	0.0073	0.0181
Diffuse	0.0118	0.0148	0.0059	0.0148
TA–54 (Waste Management)	0.0288	0.0288	0.0288	0.0288
Total ^a	13.59	33.09	10.83	13.79

^a The values reported for population doses for this alternative, as well as the other alternatives, is higher than has been reported in the recent Annual Environmental Reports. It is important to recognize that the alternatives analyzed represent increased operations when compared to recent history. The material throughput at the different facilities under the various alternatives is presented in section 3.6.

TABLE B.1.2.3–2.—Total Collective Population Doses for Each of the SWEIS Alternatives

ALTERNATIVE	DOSE (PERSON-REM/YR)
No Action	13.59
Expanded Operations	33.09
Reduced Operations	10.83
Greener	13.79

B.1.2.4 *Isodose Maps*

Individual doses have been calculated for people living within a 50-mile (80-kilometer) radius from LANL. The highest individual dose for an alternative is the dose given to the LANL site-wide MEI for that alternative. For the 50-mile (80-kilometer) region, an individual's doses are shown on the isodose maps in Figures B.1.2.4–1 through B.1.2.4–8. Figures B.1.2.4–1 through B.1.2.4–4 show doses that are more than 1 millirem per year for each of the four alternatives. Only lines that represent a dose larger than 1 millirem per year and extend (at least in part) outside the LANL boundary are shown on the isodose maps. Figures B.1.2.4–5 through B.1.2.4–8 show doses that are less than 1 millirem per year for each alternative. To estimate their doses, individuals need only find their locations on the isodose map and identify the bounding doses nearest that location. A dose of 1 millirem per year is not considered significant

B.1.2.5 *Uncertainties*

There are many factors that introduce uncertainties into the process of projecting future doses to the public from radioactive air emissions from LANL. Some of these factors are listed below.

- The radionuclide emission rates estimated by each modeled facility are based on current knowledge regarding future operations at the facility. However, the level of funding, exact activities, and exact conditions associated with future operations cannot be predicted with certainty. Therefore, the emission rate estimates cannot be viewed as accurate or precise values.
- The LANL site-wide MEI dose is sensitive to the assumptions and operations associated with LANSCE. Procedures are in place to monitor the modeled MEI dose and ensure that the 10 millirem per year limit is not exceeded. Population doses, on the other hand, are more sensitive to the assumptions and operations associated with the Firing Sites. For example, a 25 percent change in uranium use (which is assumed to mean a 25 percent change in uranium emissions) would change the population dose by about 20 percent.
- The parameters introduced into the CAP-88 model cannot be exact, especially the meteorological data. The average meteorology for a 3-year period was used in the modeling, which is a reasonable and good prediction for future years. However, any single, future year could be anomalous, resulting in a collective dose estimate different from that presented in this report. Again, active monitoring and control of atmospheric releases is conducted to ensure that the public dose limits are not exceeded.
- The modeled dose is also very sensitive to the assumed period of exposure. For the purposes of this analysis, the very conservative assumption is made that the MEI is a person who stays in the same location 24 hours a day, 365 days a year. Furthermore, it is assumed that this person is not shielded from the emissions by clothing or shelter (e.g., a building, auto, home, etc.).
- The area source term for TA-54 was calculated from AIRNET monitoring data.

There are uncertainties in those data for tritium in its water vapor form due to a recent discovery that the silica gel samplers are not collecting water with a high efficiency. It is estimated that the

underestimation, which is being quantified, will represent only a very small addition to the collective population dose and LANL MEI doses.

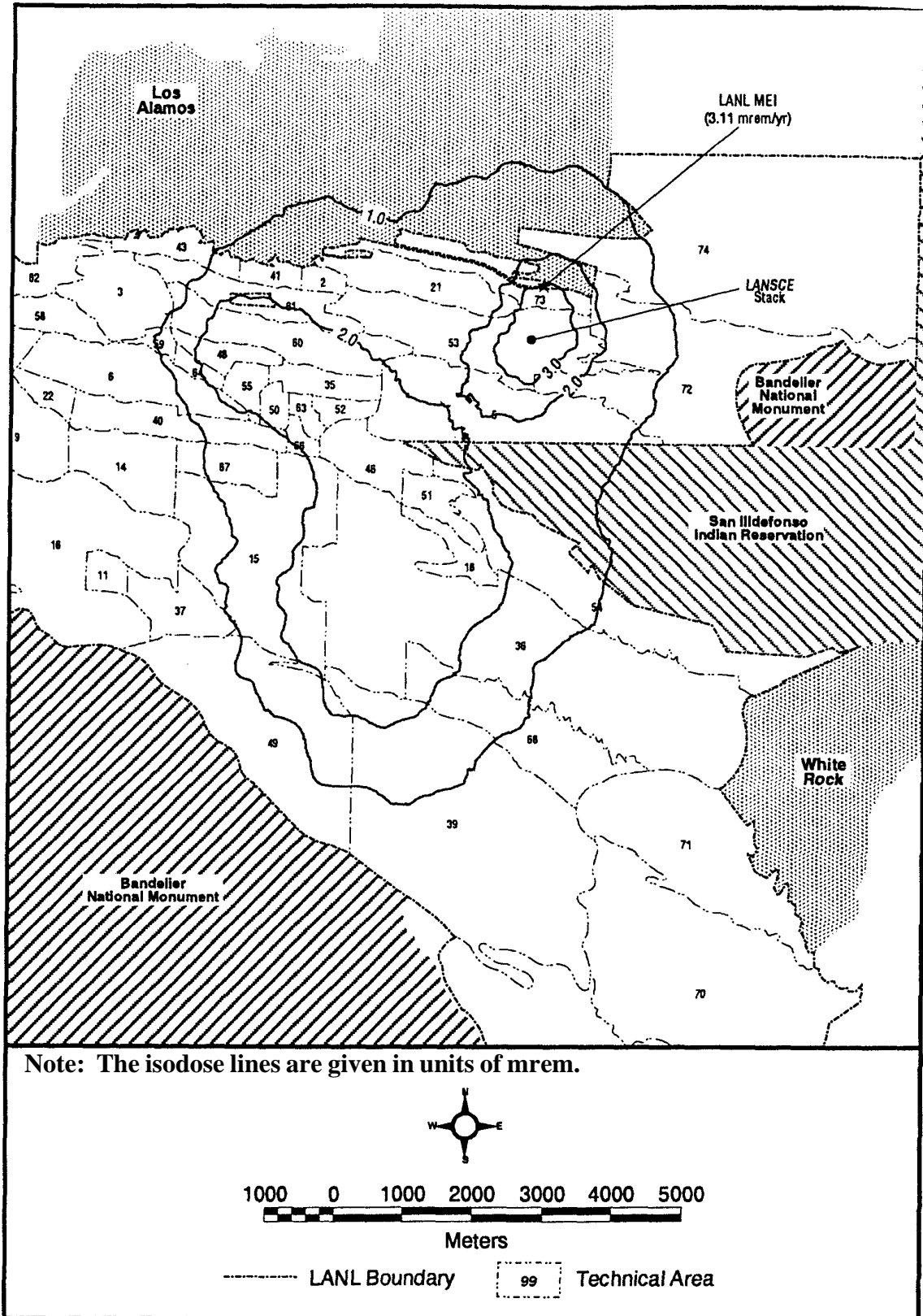

FIGURE B.1.2.4-1.—Annual Average Individual Doses Higher Than 1 Millirem per Year for the No Action Alternative.

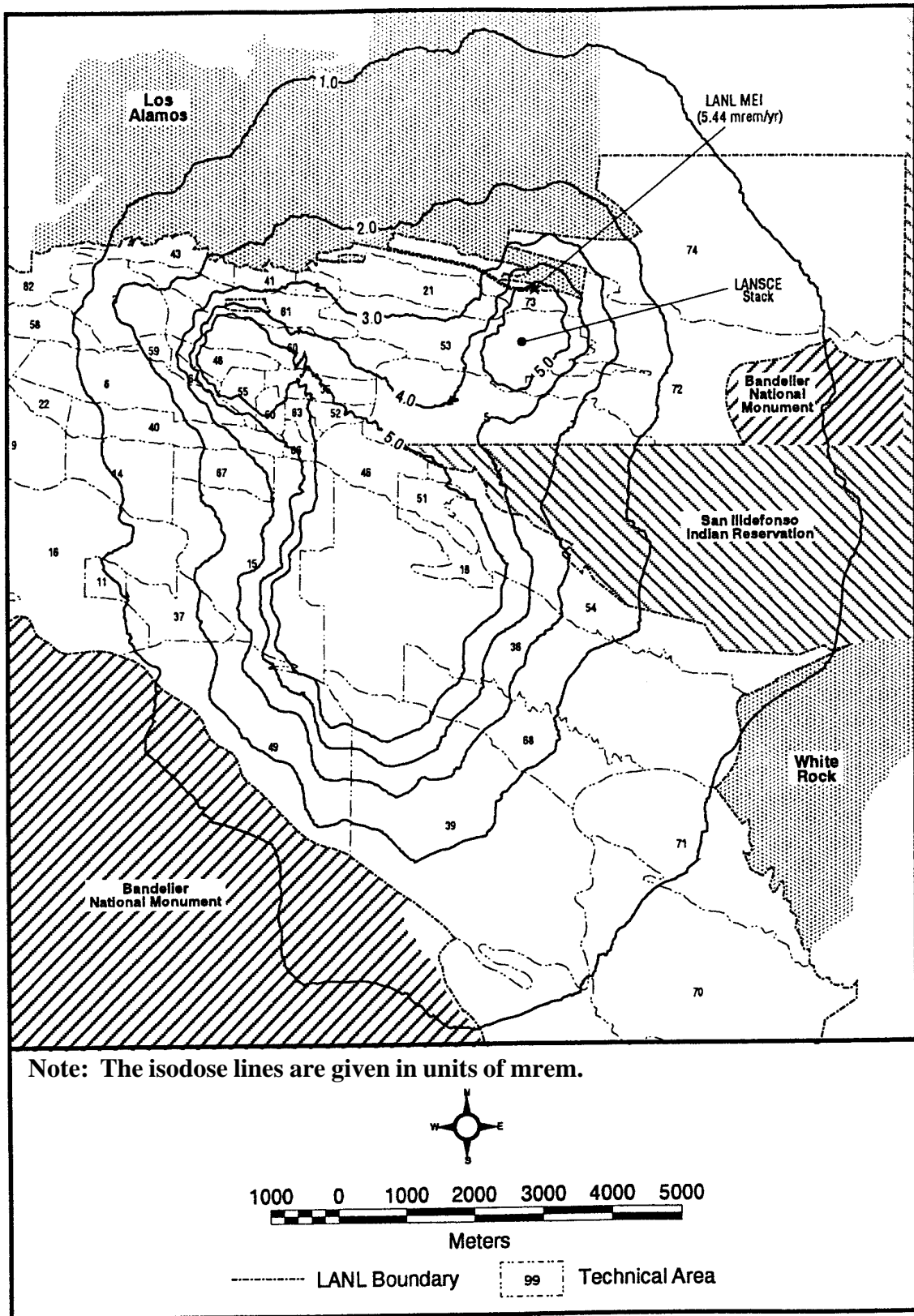

FIGURE B.1.2.4-2.—Annual Average Individual Doses Higher Than 1 Millirem per Year for the Expanded Operations Alternative.

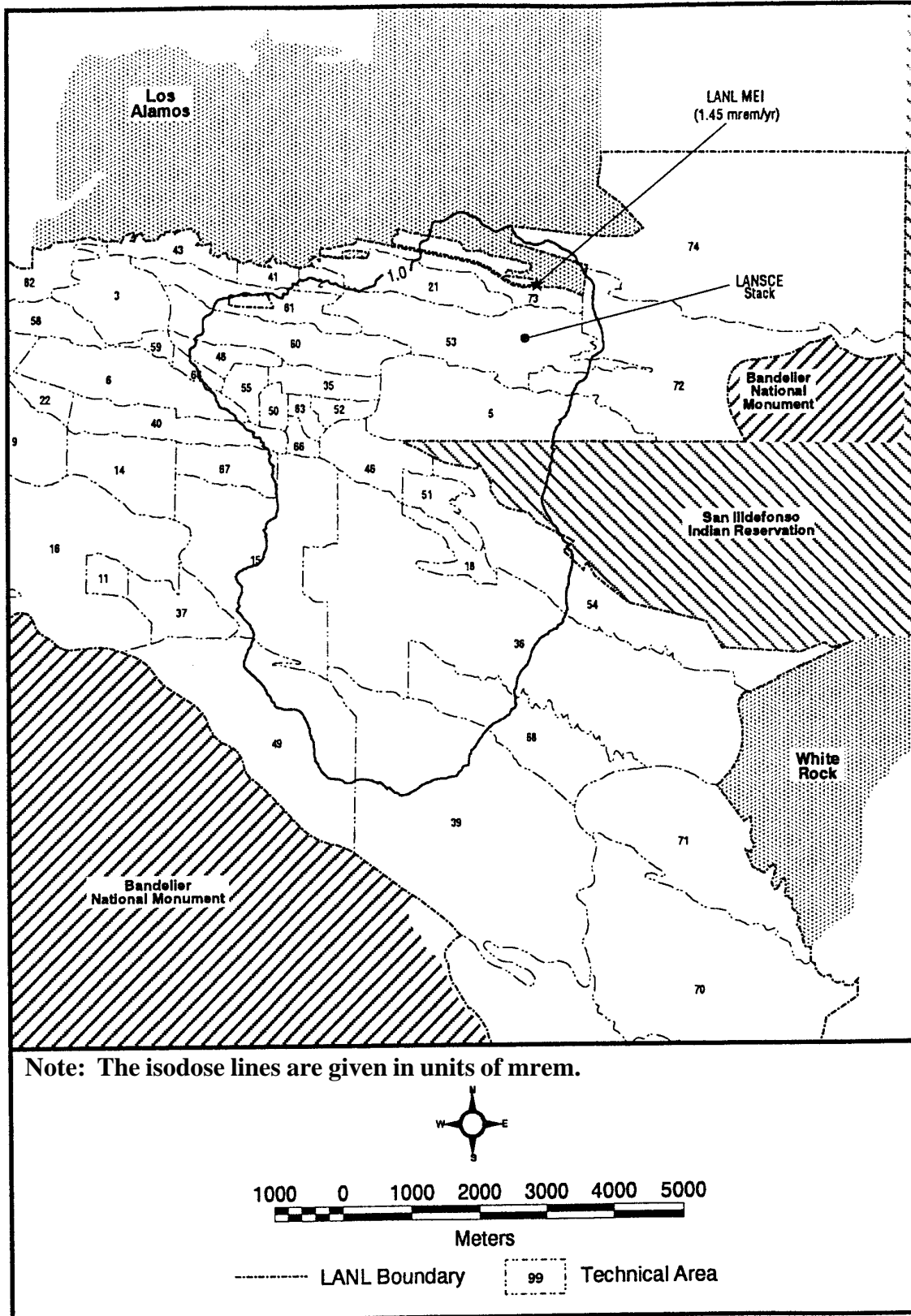
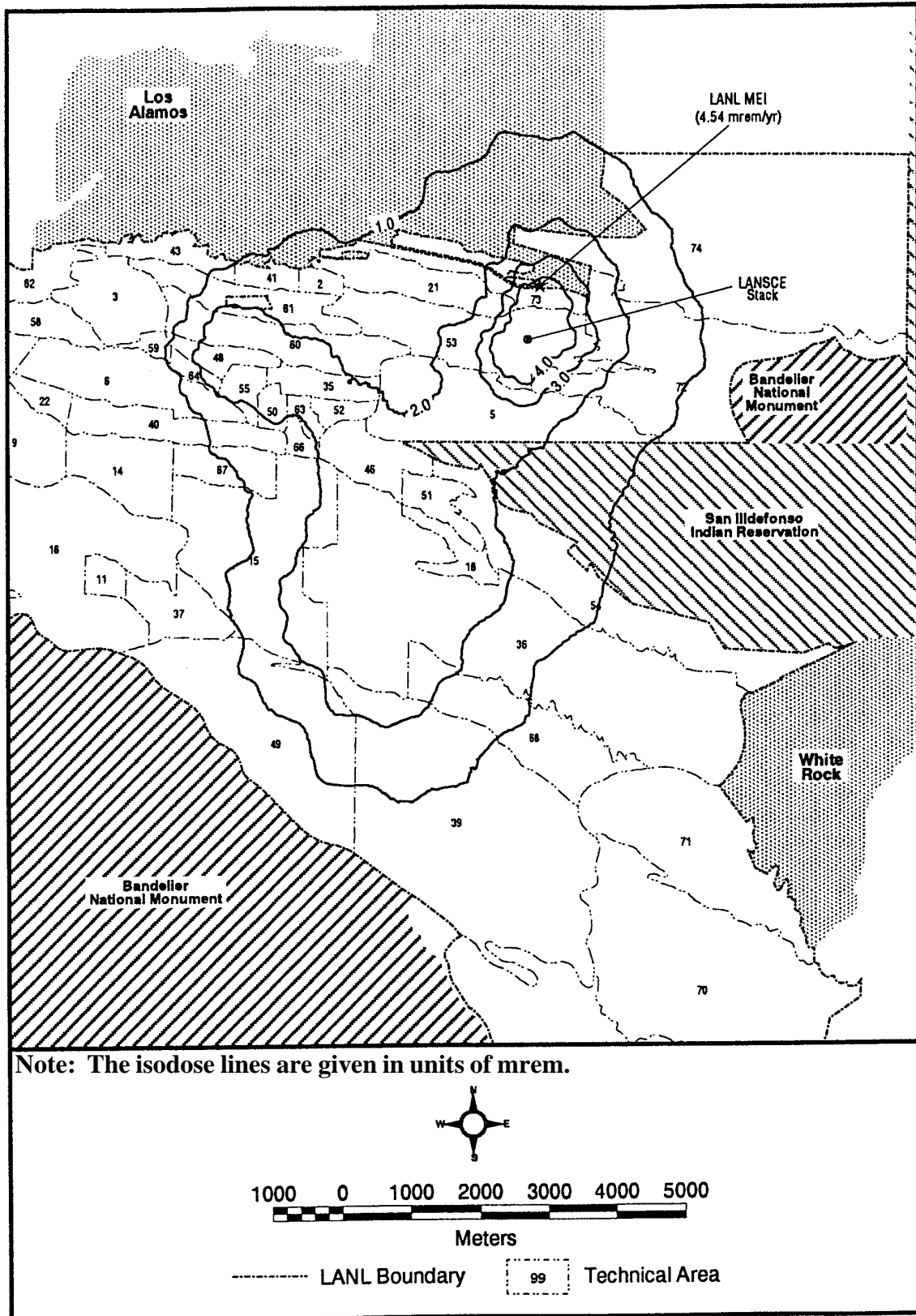
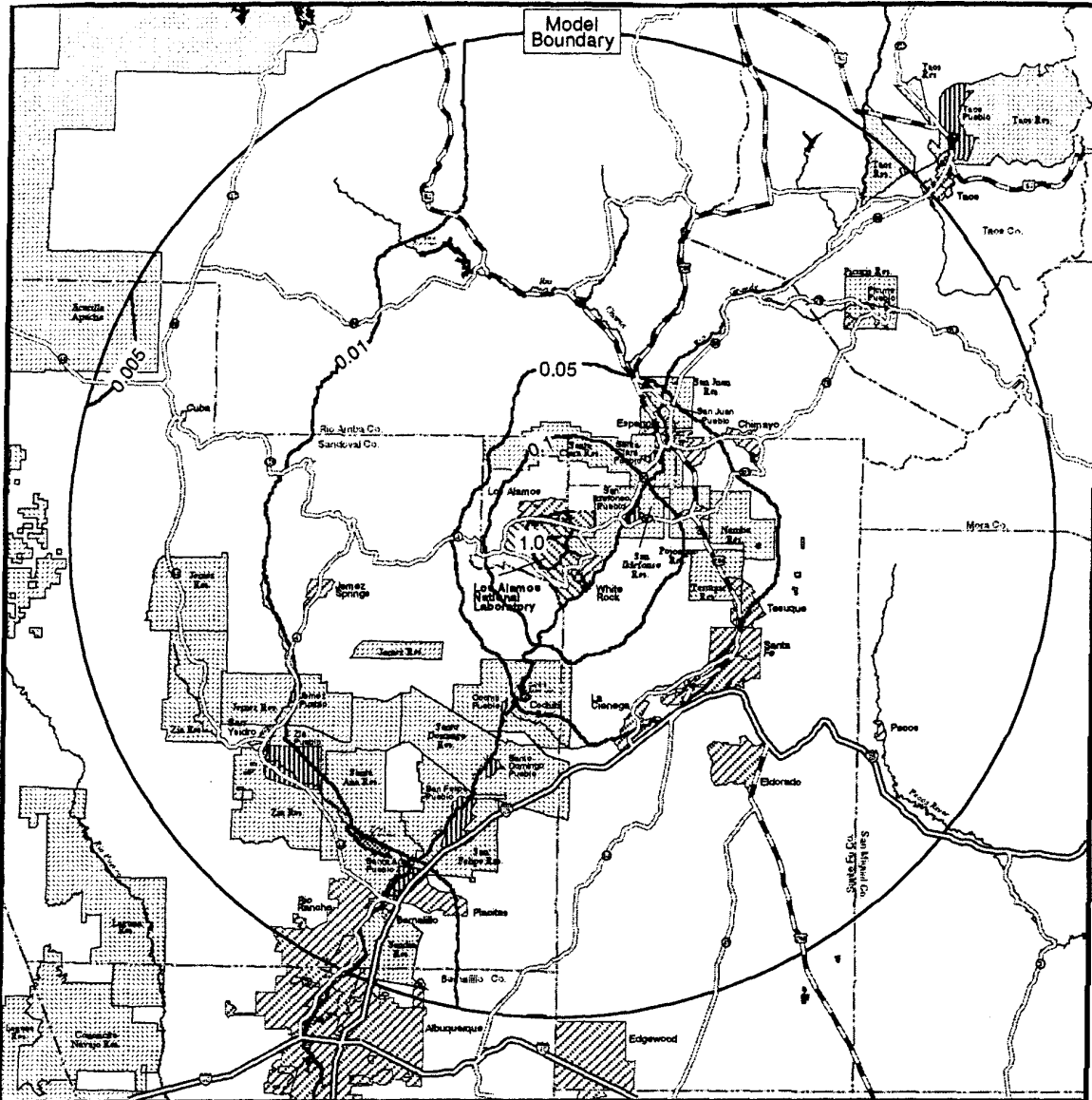

FIGURE B.1.2.4-3.—Annual Average Individual Doses Higher Than 1 Millirem per Year for the Reduced Operations Alternative.







Note: The isodose lines are given in units of mrem.

FIGURE B.1.2.4-4.—Annual Average Individual Doses Higher Than 1 Millirem per Year for the Greener Alternative.

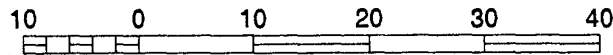
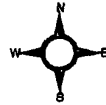

Note: The isodose lines are given in units of mrem.



-  City or Town
-  Indian Pueblo
-  Indian Reservation

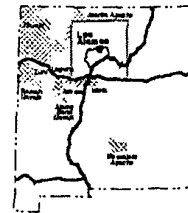

FIGURE B.1.2.4-5.—Annual Average Individual Doses Less Than 1 Millirem per Year for the No Action Alternative.

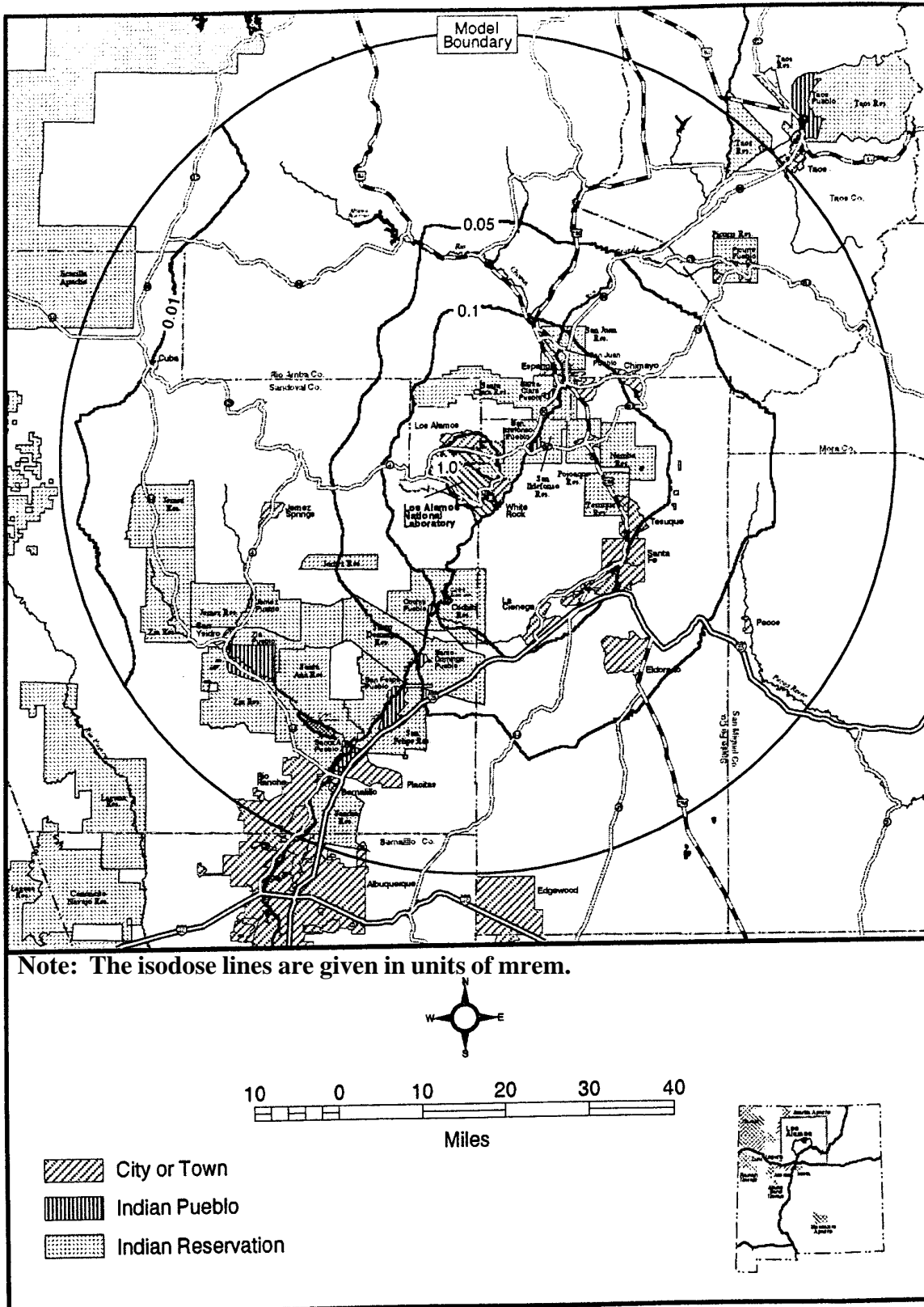

FIGURE B.1.2.4-6.—Annual Average Individual Doses Less Than 1 Millirem per Year for the Expanded Operations Alternative.

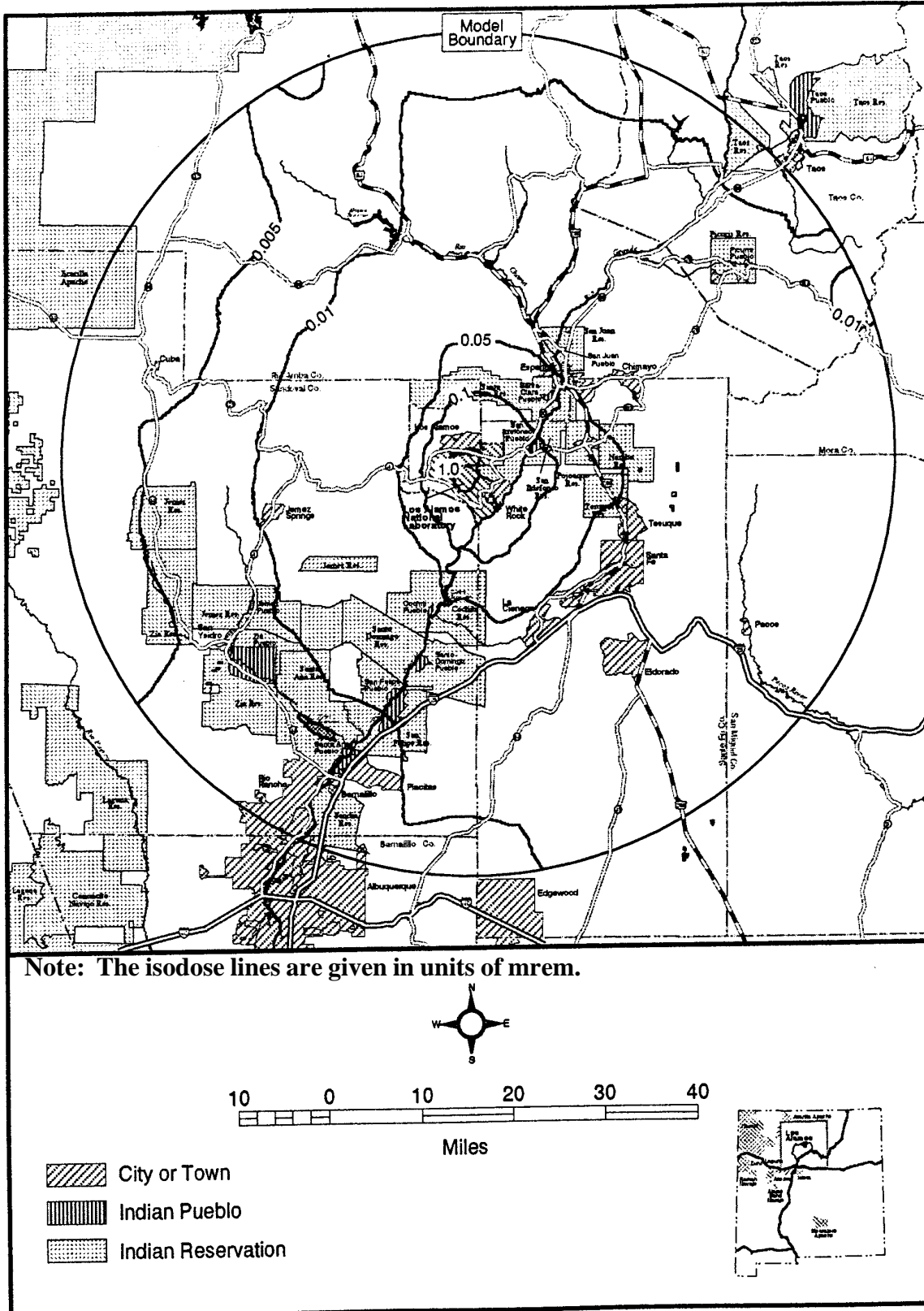

FIGURE B.1.2.4-7.—Annual Average Individual Doses Less Than 1 Millirem per Year for the Reduced Operations Alternative.

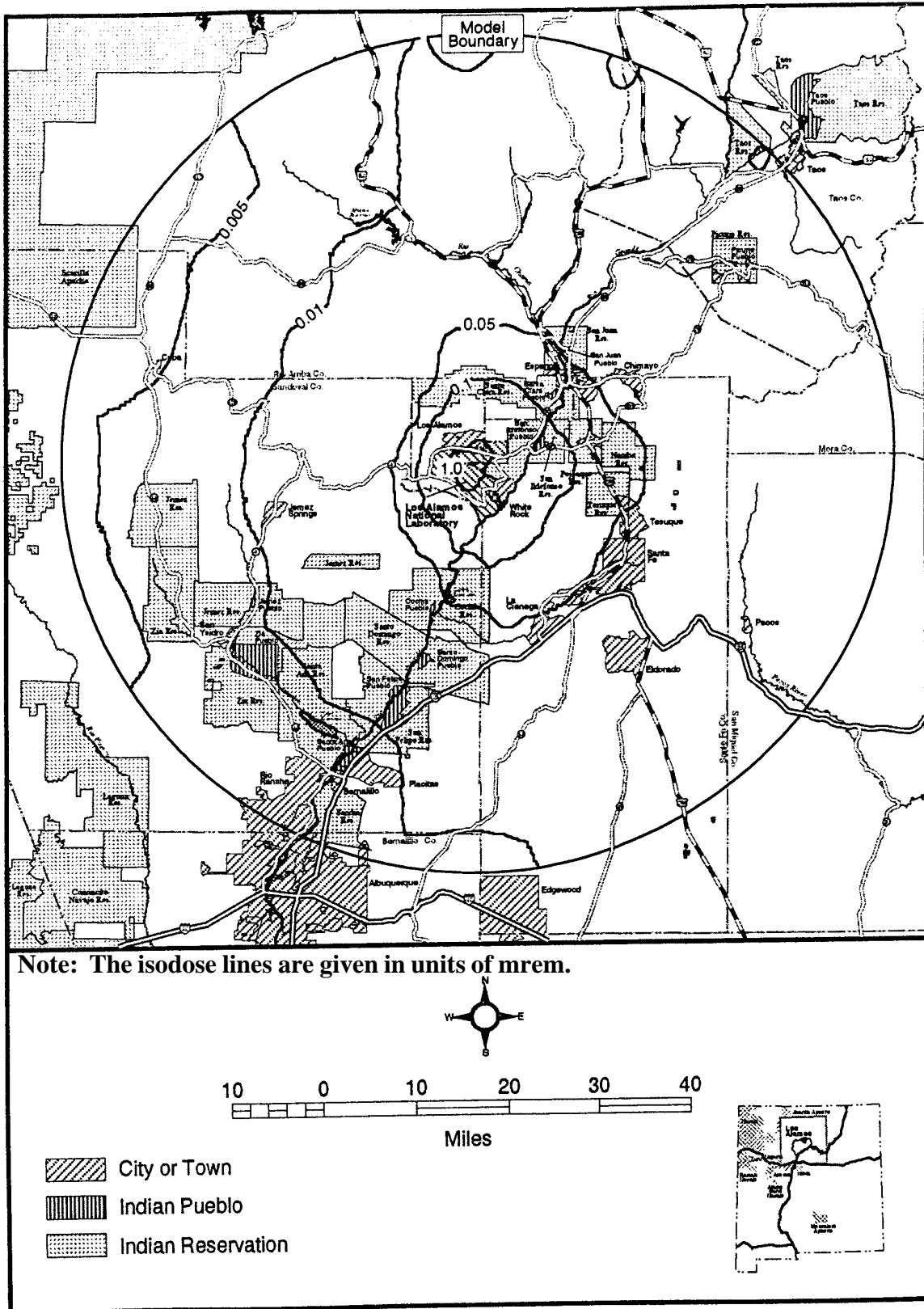

FIGURE B.1.2.4-8.—Annual Average Individual Doses Less Than 1 Millirem per Year for the Greener Alternative.

B.2 NONRADIOLOGICAL AIR QUALITY

The methodology description and the analysis results presented in chapter 5 are supplemented in this appendix with details on each aspect of modeling and analysis for criteria pollutants and toxic chemical emissions.

B.2.1 Assumptions, Data Sources, Standards, and Models

B.2.1.1 *Applicable Guidelines/ Standards and Emission Sources*

Criteria Pollutants

The *Clean Air Act* mandates that the EPA establish primary and secondary National Ambient Air Quality Standards (NAAQS) for pollutants of concern nationwide. These pollutants, known as criteria pollutants, are carbon monoxide, sulfur dioxide, nitrogen dioxide, ozone, lead, and particulate matter smaller than 10 microns in aerodynamic size (PM₁₀). As of September 16, 1997, in addition to the PM₁₀ NAAQS, a new NAAQS became effective for particulate matter equal to or less than 2.5 microns (micrometers) in aerodynamic diameter (PM_{2.5}). These new standards will not require imposition of local area controls until 2005, and compliance determinations will not be required until 2008. Additionally, EPA revised the NAAQS and associated reference method for determining ozone attainment on July 18, 1997. This standard also will be applicable to LANL.

The State of New Mexico also has established ambient air quality standards for carbon monoxide, sulfur dioxide, total suspended particulates, hydrogen sulfide, and total reduced sulfur (New Mexico Administrative Code [NMAC], Title 20, Chapter 2, Part 3). State of New Mexico ambient air quality standards are

more restrictive than the national standards and are listed in attachment 1.

Criteria pollutants released into the atmosphere from LANL operations are emitted primarily from combustion facilities such as boilers, emergency generators, and motor vehicles.

Toxic Air Pollutants

Chemicals are currently used at LANL in separately located groups of operations or laboratory complexes (TAs) that are spread out over a large geographic area (43 square miles [11,140 hectares]). Toxic air pollutants from these TAs may be released into the atmosphere from many different ongoing activities, including laboratory, maintenance, and waste management operations. Two types of toxic air pollutants are considered in this analysis: noncarcinogenic and carcinogenic.

The two database information systems used primarily in this analysis are the 1995 Automatic Chemical Inventory System (ACIS) (LANL 1995a) purchase data and the Regulated Air Pollutants (RAP) Report data (LANL 1990).

ACIS is a listing of chemicals purchased at each LANL facility in each calendar year. The 1995 ACIS list identified more than 2,000 chemicals. This list was reduced to 382 chemicals by eliminating from consideration those that do not have adequate vapor pressure in a liquid state to be evaporated during chemical operations or have very low toxicity. Fifty-one of these 382 chemicals are considered by EPA to be carcinogenic. For the purpose of this analysis, it was assumed that air emissions could result from the use of any of the 382 chemicals from any of the 30 separate TAs that purchased these chemicals. A list of these chemicals is provided in attachment 2.

RAP is a LANL site-wide nonradiological air emissions inventory that was conducted at LANL in 1990. This inventory, however, was prepared more than 7 years ago when LANL

operations were significantly different from current operations. Because these data are not current, RAPS information was used in this analysis only to supplement ACIS data and other information gathered for this study.

Noncarcinogens. *Short-Term Guideline Values.* While no national or State of New Mexico standards have been established for noncarcinogens, the New Mexico Environment Department (NMED) has developed guideline values (GVs) for determining whether a new or modified source emitting a toxic air pollutant would be issued a construction permit (NMED/AQCRs, revised November 17, 1994). These GV's are 8-hour concentrations that are 1/100 of the Occupational Exposure Limits (OELs) established by the American Conference of Governmental Industrial Hygienists (ACGIH 1997) or the National Institute of Occupational Safety and Health (NIOSH). The State of New Mexico listing was supplemented with the most current information on the lowest values for OELs from these sources. These GV's were used in this analysis in screening for potential short-term impacts of toxic releases from LANL operations.

Annual Average Guideline Values. The GV's used in this analysis are the inhalation reference concentrations (RfCs) from EPA's Integrated Risk Information System (IRIS) (EPA 1993b). RfCs are daily exposure levels to the human population (including sensitive subgroups) during a lifetime (70 years) that could occur without appreciable risk of deleterious effects.

Carcinogens. The GV's used in this analysis to estimate potential impacts of carcinogenic toxic air pollutants from LANL operations are based on an incremental cancer risk of one in a million (1.0×10^{-6}) (i.e., one person in a million would develop cancer if exposed to this concentration over a lifetime), a level of concern established in the *Clean Air Act*.

This value was used in the screening for the estimated combined incremental cancer risk

associated with all of the carcinogenic pollutants emitted from LANL facilities at any location. For the purpose of screening individual carcinogens, a cancer risk of 1.0×10^{-8} was established as the GV.

B.2.1.2 Receptors and Receptor Sets

Two sets of receptors (i.e., locations where air quality levels were estimated) were considered for the analyses of criteria and toxic air pollutants.

- The first set of receptors includes nearby identified actual locations of human activity that might be affected from the emissions from LANL facilities. These include: (1) schools, hospitals, parks and playgrounds within Los Alamos; (2) residences (including those in trailer parks) in all directions surrounding all of LANL facilities in Los Alamos County; and (3) towns, cities, and sensitive national and cultural areas within approximately 50 miles (80 kilometers) of LANL. These receptors, which are listed in attachment 3, are referred to as sensitive receptors.
- The second set of receptors includes all of the closest off-site (i.e., fence line) locations (in 10-degree increments) around each TA to which the public could have access. These receptors are referred to as fence line receptors.

The potential impacts of air pollutants on workers employed at the LANL facilities were not considered as part of this analysis. Different regulations apply to an occupational setting, and the controlled nature of the work, along with surveillance systems associated with these controls, restricts routine exposures for workers. This analysis is focused on exposure to the public, and is based on a methodology that initially assumes that chemicals that are purchased are entirely available for release to the atmosphere outside the facility in which the chemicals are used.

Air quality standards have been established by the State of New Mexico for criteria pollutants for both short-term (i.e., 1-hour, 3-hour, 8-hour, and 24-hour) and long-term (e.g., 30-day, quarterly, and annual) time periods. In addition, GVs also were developed for toxic pollutants for both short-term (8-hour) and long-term (annual) time periods. Using these standards and GVs, the potential impacts of the pollutant emissions from LANL operations on these receptor sets were analyzed as discussed in the following paragraphs.

Criteria Pollutants

Short-term and long-term impacts for CO, NO₂, and SO₂, TSP, PM₁₀, and lead were estimated at the sensitive receptors, and the results were compared with applicable air quality standards. Both time frames were analyzed to address the potential short-term (acute) and long-term (chronic) impacts of these pollutants at locations where the public could have both short-term and long-term exposure to emissions from LANL facilities. Hydrogen sulfide and total reduced sulfur emissions are associated mostly with oil and gas industry; therefore, analysis for these pollutants was not necessary at LANL.

Short-term impacts also were analyzed at the fence line receptors surrounding TA-3, TA-16, and TA-21 in order to account for potential short-term exposure near the locations with relatively large combustion sources. The combustion sources at the other TAs are minor (primarily small boiler units and emergency generators) relative to the larger combustion units found at TA-3, TA-16, and TA-21, and are mostly for emergency back-up. The potential impacts at the fence line receptors of these minor sources were not considered.

Toxic Air Pollutants

Noncarcinogens. The potential short-term (acute) and long-term (chronic) impacts of these pollutants at locations where the public could

have both short-term and long-term exposure to emissions from LANL facilities were considered.

Short-term impacts were analyzed at the fence line receptors. Long-term impacts were not considered at these receptors because, although it is possible that the public could have access to fence line areas for short periods of time, the fence line locations are not places where visitors can freely walk around, nor is pedestrian traffic at these locations encouraged or actually encountered on a regular (long-term) basis.

Carcinogens. The annual impacts from the emissions of carcinogenic toxic air pollutants were analyzed at the sensitive receptors. Although GVs for short-term exposure were used in the screening steps, the more meaningful comparisons were to long-term GVs for sensitive receptors.

B.2.1.3 Air Quality Dispersion Models

The EPA's Industrial Source Complex Air Quality Dispersion Model (ISC-3) was used for both the criteria and toxic pollutant analyses. ISC-3 is a versatile model that is often used to predict pollutant concentrations from continuous point, area, volume, and open disposal cell sources (EPA 1992b). This versatile model is often preferred by the EPA because of the many features that enable the user to estimate concentrations from nearly any type of source emitting nonreactive pollutants.

EPA's PUFF model was used for a screening level analysis of emissions from LANL's High Explosives Firing Sites (HEFSs) at TA-14, TA-15, TA-36, TA-39, and TA-40. The PUFF model is designed to estimate downwind concentrations from instantaneous releases of pollutants (EPA 1992d).

The HOTSPOT code was used in combination with the ISC-3 model for a detailed analysis of

emissions from HEFF in order to provide a more readily usable input data file to the health effects analysis used in this SWEIS than provided by PUFF. The HOTSPOT code is designed for detonation of high explosives, and was used specifically to provide input data to the ISC-3 model (ORNL-LLNL 1996).

B.2.2 Criteria Pollutants—General Approach

The combustion sources that were evaluated in the analysis of criteria pollutants are listed in attachment 1. An atmospheric dispersion modeling analysis was conducted to estimate the combined potential air quality impacts of the emissions from each of these emission sources.

No quantitative analysis of vehicular-related emissions was performed as part of this analysis, but this emission source was included in the assumed background. Although the project alternatives may have different effects on the travel patterns in the study area as a result of changes in the number of LANL employees who would commute to Los Alamos, the future population of Los Alamos is expected to be the same under all of the alternatives. Therefore, the change in regional emissions under any of the future project alternatives are not expected to be more than a few (less than 5) percent. Because the study area is in attainment for the pollutants that are released primarily from motor vehicles (carbon monoxide and ozone precursors and nitrogen oxides [NO_x]) and because there are no nearby heavily congested traffic areas or major sources or ozone precursors (i.e., hydrocarbons and nitrogen oxides), no potentially significant air quality impacts are expected from the project alternatives.

B.2.2.1 Criteria Pollutants—Methodology

The analysis of combustion-related pollutants used standard analytical modeling techniques based on atmospheric dispersion modeling and emissions estimated under peak and actual annual average operating conditions of each major combustion unit. This information, together with stack locations and exhaust parameters (i.e., heights, diameters, flow rates), was available from LANL's air quality permit applications. Estimates of future emission rates were based on the operations anticipated under the Expanded Operations Alternative—the worst-case alternative with respect to emission rates from the combustion sources. These emissions were modeled using the ISC-3 model and meteorological data collected at TA-6. The methodology and procedures used are provided in attachment 1.

B.2.2.2 Results of Criteria Pollutant Analysis

The results of the analysis of criteria pollutants from LANL's combustion sources are presented in attachment 1. As shown, the highest estimated concentration of each pollutant is below the appropriate ambient air quality standard. None of the project alternatives, therefore, are predicted to significantly impact criteria pollutant levels.

B.2.3 Toxic Air Pollutants—General Approach

Unlike a production facility with well-defined operational processes and schedules, LANL is a research and development facility with great fluctuations in both the types of chemicals emitted and their emission rates. Because LANL's toxic air pollutant emission rates are relatively low (compared to releases from production facilities), vary greatly, are released

from hundreds of sources spread out over a large geographic area, and are well below the state's permitting threshold limits, toxic air pollutant emissions are not monitored. Current emission rates and stack parameter information necessary to conduct a conventional air quality analysis of the releases of toxic air pollutants are therefore not available.

An alternative approach was developed specifically for this analysis to estimate the potential air quality impacts of these pollutants. This approach is based on the use of screening level emission values (SLEVs). SLEVs are conservatively estimated hypothetical emission rates for each of the toxic air pollutants that could potentially be emitted from each of LANL's TAs and that would not result in air quality levels harmful to human health under current or future conditions. These SLEVs were compared with conservatively estimated pollutant emission rates on a TA-by-TA basis to determine potential air quality impacts of toxic air pollutants from LANL operations. This process consisted of the following steps:

- From over 2,000 chemical compounds listed as being used at LANL, 382 toxic air pollutants (including 51 carcinogens) were selected for consideration based on chemical properties, volatility, and toxicity.
- A methodology based on SLEVs was used to estimate the potential worst-case impacts of the toxic air pollutants. SLEVs for each chemical for each TA were compared with emission rates conservatively estimated from chemical use rates. If a conservatively estimated emission rate for a given pollutant from a given TA was less than SLEV, that pollutant emission source was deemed not to have the potential to cause significant air quality impacts, and, as such, no detailed analyses was required; if SLEV was less than the estimated emission rate for a given pollutant from a given TA, a more detailed analysis was conducted.

- An additive impact analysis was conducted to estimate the potential total impact from the emissions of each pollutant from more than one TA and the total incremental cancer risk from all of the carcinogenic pollutants combined at any of the sensitive receptor locations considered.

The methodology used in this analysis followed modeling guidelines for toxic pollutants established by the EPA (EPA 1988, EPA 1992c, EPA 1992e, and EPA 1992f) in that it first uses screening level evaluations based on conservative assumptions and resulting in maximum potential impacts, followed by more detailed analyses based on more realistic assumptions. The overall procedure used for this air quality assessment, including the development of SLEVs, is summarized in Figures B.2.3-1 and B.2.3-2. Also shown on these figures are the procedures used to compare SLEVs with the available emission data and the steps taken to evaluate the pollutants with potentially significant impacts. Each pollutant with the potentially significant impacts (as a result of the screening-level analyses) was subjected to progressively more detailed and more realistic evaluations.

B.2.3.1 Toxic Pollutants— Methodology for Individual Pollutants

Screening Level Analysis

Once SLEVs (both short-term and long-term) were established for each of the toxic air pollutants on a TA-specific basis (attachment 4, Methodology), a comparison was made between these values and conservatively estimated emission rates based on the Expanded Operations Alternative. A ratio was developed for each chemical by dividing the SLEV by the estimated emission rate (SLEV/Q).

These results, in the form of worksheets (an example for TA-3 is provided in attachment 5),

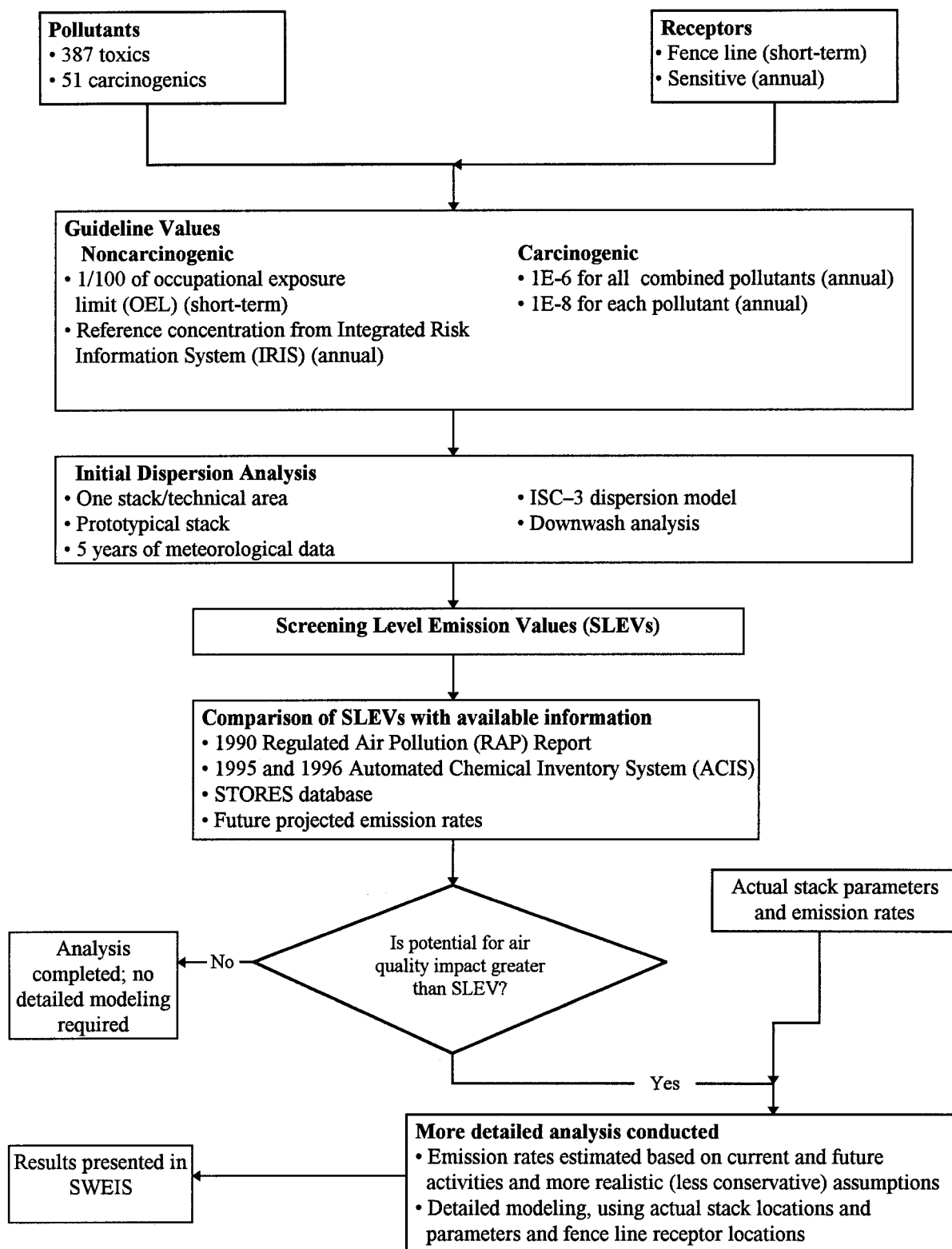

FIGURE B.2.3-1.—Process Used for Evaluating Toxic Air Pollutants.

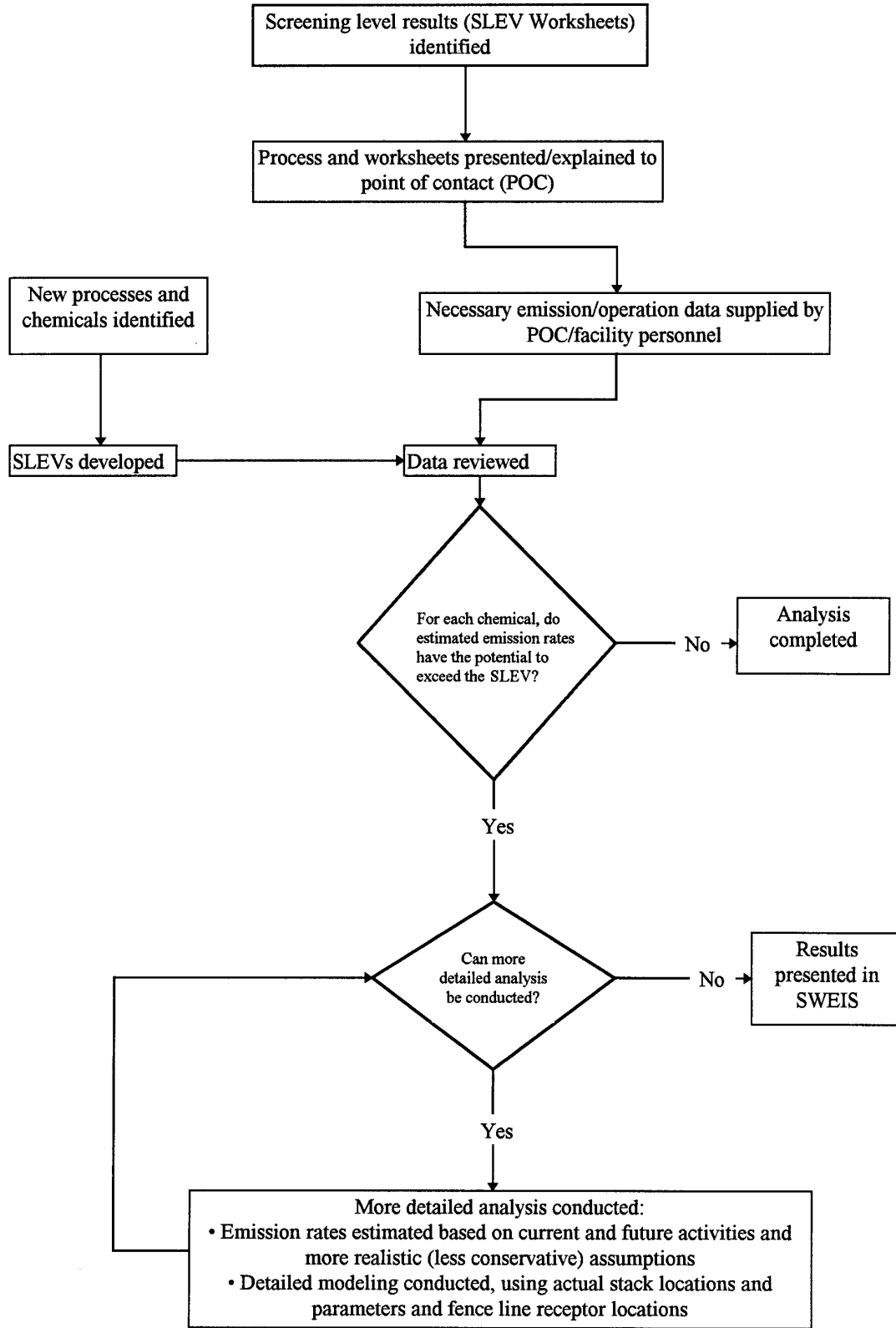

FIGURE B.2.3-2.—Procedures for Evaluating Potential Impacts of Toxic Air Pollutant Emissions from Each Technical Area.

were presented to knowledgeable site personnel who are aware of the activities and processes that are currently occurring at each TA as well as those that might occur in the future. In order to streamline the process, the relationship between SLEVs and the estimated emission rates for each TA were presented in two data sets.

The first data set included those chemicals with SLEV/Q ratios greater than 100. For each of these chemicals, a determination was made as to whether the utilization of that chemical would increase by more than one hundred times under future operation(s) of LANL under any of the project alternatives considered. Essentially, this meant that for each TA a determination had to be made as to whether the utilization of a chemical would increase over current use rates by a factor of 100. If a determination could be made that the future use of that chemical would not increase by this factor, no further evaluation of that chemical was required. If such a determination was not possible, a more detailed analysis was conducted.

The second data set included all the chemicals with a SLEV/Q ratio less than 100, and included those chemicals with a SLEV/Q ratio greater than 1 but less than 100, as well as those chemicals with a ratio less than 1. For each chemical with a ratio greater than 1 but less than 100, an evaluation was made as to whether the estimated emissions under any of the future alternatives would exceed the SLEV. Essentially, this meant that for each TA a determination had to be made as to whether the utilization of that chemical would increase over current use rates by a factor greater than the SLEV/Q ratio. If a determination could be made that the future use of that chemical would not increase by this factor, no further evaluation of that chemical was required. If such a determination was not possible, a more detailed analysis was conducted. For those chemicals with a SLEV/Q ratio less than 1 (i.e., SLEVs were potentially being exceeded under current

conditions), more detailed analyses were conducted.

Two exceptions to the details associated with this approach were made. Information on the TAs for high explosives operations were derived using a model more appropriate for screening short-term exposure concentrations under those conditions (attachment 13). The second involved screening the emissions of chemicals from The Health Research Laboratory (HRL) at TA-43. Because of the proximity of HRL to actual receptors, all analyses for carcinogens as well as noncarcinogens were performed for actual receptors rather than fence line receptors (attachment 14).

Detailed Analysis

The detailed air quality analysis consisted of one or both of the following steps:

- Development of emission rates and source terms parameters using actual process knowledge
- Dispersion modeling using actual stack parameters and receptor locations

Two consequences may result from the detailed analysis for each chemical from each TA: (1) either there is no potential to contravene a GV (in which case no additional analyses were required), or (2) there is a potential to contravene a GV (in which case additional analyses were required). A pollutant with the potential to contravene a GV was subject to evaluation in the health and ecological risk assessment process for this SWEIS.

B.2.3.2 Results of the Toxic Pollutant Analysis— Individual Pollutants

Screening Level

The first data set considered those chemicals with SLEV/Q ratios greater than 100. For more than 90 percent of the toxic air pollutants, a determination was made (based on current and proposed operations of the TAs) that the utilization of these chemicals would not increase by more than 100 times under any of the project alternatives. The second data set included chemicals with SLEV/Q ratios greater than 1 but less than 100, and ratios less than 1. A determination was made as to whether the utilization of that chemical would increase over current use rates by a factor greater than the SLEV/Q ratio. The list of carcinogens also was reduced from 51 to 35 because some of the chemicals are no longer used and are not projected for future use. Based on worksheets for the chemicals in these data sets, and information on potential future use, operations at 13 locations were identified with the potential to exceed a GV.

Detailed Analysis

Detailed analyses were conducted for the following emission sources:

- Methylene chloride emissions at TA-3 (attachment 7)
- Beryllium emissions at TA-3 (attachment 8)
- Nickel dust emissions at TA-3 (attachment 9)
- Paint booth (primarily volatile organic compound) emissions at TA-3 and TA-60 (attachment 10)
- Incinerator emissions (primarily metals and volatile organics) at TA-16 (attachment 11)
- Emissions (primarily volatile organic compounds) from open burning operations at the High Explosives Treatment and Disposal Facility at TA-16 (attachment 12)
- Emissions (primarily metals) from High Explosives Firing Site (HEFS) operations at TA-14, TA-15, TA-36, TA-39, and TA-40 (attachment 13)
- Emissions (primarily volatile organic compounds) from the Health Research Laboratory at TA-43 (attachment 14)
- Chloroform emissions at TA-53 (attachment 15)
- Beryllium emissions at TA-55 (attachment 16)
- Nitric and hydrochloric acid emissions at TA-55 (attachment 17)
- Nitric and hydrochloric acid emissions at TA-59 (attachment 18)
- Ozone Emissions at TA-53 (attachment 19)

Detailed Analyses—Results

Emissions from two sources were referred to the health and ecological risk analysis process. The analysis for TA-43 showed the potential to exceed the GVs for four chemical carcinogens from HRL: chloroform, trichloroethylene, formaldehyde, and acrylamide.

The detailed analysis for HEFF indicated that the same chemicals that had the potential to exceed a GV in the previous screening step, would also have the potential to exceed their respective GVs using somewhat different parameters and a different model than used in the screening analysis. A different model was used in the detailed analysis in order to provide output data in a form more readily usable for the health risk analysis. Additional information on the following chemicals was referred to the health and ecological risk assessment process for this SWEIS:

- Depleted uranium, beryllium, and lead from TA-15
- Depleted uranium, beryllium, and lead from TA-36

- Beryllium and lead from TA-39
- Depleted uranium and lead from TA-14

B.2.3.3 Toxic Pollutants— Methodology for Combined Impacts Analyses

The following analyses were conducted to ensure that the combined effects from the releases of all of the chemicals from all the TAs would not exceed the GVs.

Noncarcinogens

An analysis of potential short-term impacts at a TA's fence line receptors showed that the 8-hour impacts from the releases of that TA were significantly greater (i.e., more than two orders of magnitude) than the impacts from the releases of a nearby TA. This is because the TAs are relatively far apart in comparison to the distances between the emission sources of a TA and its fence line receptors. Therefore, it is unlikely that the additive short-term impacts of noncarcinogenic pollutants at the fence line receptors of a TA would be significantly different from the maximum concentrations previously estimated for that TA.

An analysis of annual potential impacts at sensitive receptors showed that these impacts were significantly less (i.e., less than two orders of magnitude) relative to the appropriate GVs than the corresponding short-term impacts at the fence line receptors. Therefore, it is unlikely that the additive annual impacts of the noncarcinogenic pollutants at the sensitive receptors would be significant.

Carcinogens

Two different versions of additive impacts for carcinogens are presented. Both consider impacts at sensitive receptors based on annual ambient concentrations of pollutants. Short-term additive impacts for carcinogens at fence line receptors were not considered for the same

reasons as for noncarcinogens. However, long-term impacts at sensitive receptors were considered because EPA considers in their standard setting process that risk from carcinogens can be additive for all carcinogenic chemicals.

The first version considered whether emissions of the same chemical from all TAs (whether or not it was actually used at that TA), at the SLEV rate (whether or not that maximum rate was actually projected at that TA) would exceed the total guideline risk value of 1×10^{-6} . The risk due to exposure at the maximum concentration over a lifetime for any receptor for each of the TAs was added to the separately calculated maximum concentration for any receptor for each of the other TAs, regardless of whether the same receptor was indicated.

The second version modeled simultaneous emissions of the same chemical at actual projected rates for each of the TAs, and recorded the maximum concentration at any receptor location. The risk due to exposure at that concentration over a lifetime was then added to the risks calculated in a similar fashion for each of the other chemicals. Risks were added regardless of whether or not the same receptor was involved. That total risk was also compared to the guideline risk value of 1×10^{-6} of any excess cancer from a lifetime of exposure.

B.2.3.4 Toxic Pollutants—Results of Combined Impact Analysis

Releases of Each Carcinogenic Pollutant from All TAs

The estimated combined cancer risk associated with releases of each of these pollutants from all TAs is 1.23×10^{-7} , which is below the GV of 1.0×10^{-6} . As such, no potentially significant air quality impacts were estimated.

Releases of All Carcinogenic Pollutants from All TAs

Results of this analysis are presented in attachment 6. As shown, the potential combined incremental cancer risk associated with releases of all carcinogenic pollutants from all TAs is slightly above the GV of 1.0×10^{-6} .

The major contributors to the estimated combined cancer risk values are chloroform, formaldehyde, and trichloethylene from HRL at TA-43 and multiple sources for methylene chloride. The estimated maximum cancer risk for each of these individual pollutants is 8.74×10^{-7} , 5.17×10^{-8} , 6.73×10^{-8} , and 6.84×10^{-8} , respectively. Of these, the relative contribution of chloroform emissions alone to the combined cancer risk value is more than 87 percent. The impacts of TA-43 emissions are due to a combination of relatively high emission rates, close proximity between receptors and sources, and the elevation of the receptors.

Because the result of this analysis was slightly above the specified GV of 1.0×10^{-6} and a

simplifying but conservative approach was used that added the maximum risk from each chemical even though different receptors may have been involved, a more detailed analysis that considered the impact at each specific receptor location was conducted. This more refined analysis estimated the combined cancer risk at each of the 180 sensitive receptor locations.

As shown in attachment 6, the combined incremental cancer risks associated with releases of all carcinogenic pollutants from all TAs at the receptor locations where these impacts actually occur are slightly above the GV of 1.0×10^{-6} at the two locations within the LANL medical center: 1.17×10^{-6} at a receptor in an air intake duct and 1.07×10^{-6} at an operable window. Because the estimated cancer risk at these two receptor locations is slightly above the GV of 1.0×10^{-6} , these results were referred to the health and ecological risk assessment processes for this SWEIS.

ATTACHMENT 1

ANALYSIS OF CRITERIA POLLUTANTS FROM COMBUSTION SOURCES

Technical Areas: TA-3, TA-8, TA-15, TA-16, TA-18, TA-21, TA-22, TA-33, TA-35, TA-39, TA-41, TA-43, TA-46, TA-48, TA-49, TA-50, TA-53, TA-54, TA-55, TA-58, TA-59, TA-61, TA-63, and TA-64.

Emission Sources

The sources of criteria pollutant emissions at LANL are mostly combustion facilities. The largest contributors are steam plants and an asphalt plant. There are also several smaller sources. The following emission sources were considered:

MAJOR SOURCES	LOCATION	FUEL
Steam Plant	TA-3-22-1	Natural gas/oil # 2
Steam Plant	TA-21-357-1	Natural gas/oil # 2
Replacement Boiler	TA-16-4	Natural gas
Replacement Boiler	TA-16-5	Natural gas
Replacement Boiler	TA-16-6	Natural gas
Replacement Boiler	TA-16-13	Natural gas
Asphalt Heater	TA-3-73-2	Oil #2
Water Pump	TA-54-1013	Natural gas
Incinerator	TA-16	Solid waste/waste oil

Note:

Emissions from the following smaller combustion sources also were considered.

- 62 miscellaneous boilers located at various TAs
- 149 standby emergency generators (7 natural gas, 50 diesel, and 92 gasoline fueled)

Pollutants Considered

As required by the *Clean Air Act*, NAAQS have been established for six major air pollutants: CO, NO₂, ozone (O₃), particulate matter smaller than 10 microns (PM₁₀), SO₂, and lead (Pb). Each of these pollutants was considered.

Emission Rates

Major Assumptions

1. For the dual-fueled boilers, fuel oil emission rates were used to estimate short-term concentrations, and natural gas emission rates were used to estimate annual emission rates.
2. Emission factors were obtained from EPA's Compilation of Air Pollution Emission Factors (AP-42) (EPA 1995).
3. Peak load emission rates ($ER_{\text{peak load}}$) were estimated based on the capacity of each unit.

$$ER_{\text{peak load}} = \frac{\text{Unit Capacity} / \text{Design Capacity} \times \text{Emission Factor}}{\text{Heating Value of Fuel}}$$

See Tables A and B of this attachment.

4. Annual average emission rates (ER_{annual}) were based on the annual fuel consumption rates (assuming that a 100 percent capacity was used).

$$ER_{\text{annual}} = \text{Emission Factor} \times \text{Fuel Usage}$$

See Table C of this attachment.

5. PM_{10} emissions during the combustion of diesel and gasoline fuels or fuel oil were conservatively assumed to be half of the total suspended particulate (TSP) emissions. Particulates emitted during the combustion of natural gas are less than 1 micron (1 micrometer) in diameter; hence, for natural gas combustion, PM_{10} emissions were considered equal to TSP emissions.
6. It was conservatively assumed, as per New Mexico Air Quality Bureau's guidelines, that 40 percent of exhausted NO was converted to NO_2 when the exhaust plume reached fence line receptors a few hundred meters away from the source. Conversion to NO_2 depends on the presence of ozone in the surface atmospheric layer. It usually takes several hours for full conversion.
7. Based on the LANL information, it was assumed that emergency and standby generators operate a maximum of four continuous hours a day.

Dispersion Modeling Analysis

The EPA Industrial Source Complex model, Version 3 (ISC-3) was applied in the analysis of criteria pollutants. ISC-3 is a steady-state Gaussian dispersion model validated to be used in a short- and a long-term mode in regulatory and nonregulatory applications. The model is capable of handling multiple point sources, stack-tip downwash calculation, buoyancy-induced dispersion, as well as having an algorithm to account for the aerodynamic downwash due to the nearby buildings. The actual options that were used to analyze emissions from combustion sources are as follows:

- In the ISC-3 short-term mode:
 - Stack-tip downwash
 - Buoyancy-induced dispersion

- Final plume rise
- Calm winds processing
- Default wind profile exponents and potential temperature gradients
- Simple terrain
- Rural dispersion
- Aerodynamic downwash (where applicable)
- Constant emission rates throughout the modeling period
- No precipitation scavenging

Other assumptions include:

- All chemicals are released to the atmosphere rather than used in process or product, or sent to waste disposal or recycling after use.
- There is no time spent indoors or inside automobiles; whereas, people actually spend more than 80 percent of their time indoors. Being inside would cut the concentration by half as a minimum.

Modeling Procedures

1. TA-3, TA-21 and TA-16 boiler plants were modeled using actual emission locations and actual stack parameters, as provided by LANL. Wake effects of the boiler buildings and buildings in the immediate vicinity of the emission sources were considered.
2. The waste incinerator at TA-16, the water pump at TA-54, and the asphalt plant heaters at TA-3 were modeled using actual locations and stack parameters, as obtained from LANL. Wake effects of the incinerator building were considered.
3. The emission rates of the other combustion sources considered (i.e., small boilers and standby and emergency generators—natural gas, diesel and gasoline fueled) were summed up by TA and modeled as if their combined emissions were released from the center of the TA where they are located. The following prototypical stack and stack parameters were assumed for each of these sources.
 - Stack height: 6 meters
 - Stack diameter: 0.5 meters
 - Stack exit velocity: 9 meters per second
 - Stack temperature: 127°C
4. Impacts from combustion sources were considered for both peak and normal (annual average) operating conditions. Peak load emissions were used to estimate short-term impacts and annual average emissions were used to estimate long-term impacts.
5. Emergency and standby generators were modeled to estimate short-term impacts only.
6. Five years of Los Alamos meteorological on-site observations for years 1991 through 1995 were used in dispersion analysis. These 5 years of data were obtained by using the EPA PC RAMMET program, with surface observations and morning and afternoon mixing heights data as inputs. The

surface observations were collected at the TA-6 meteorological tower at LANL. Mixing heights data were estimated based on the Albuquerque upper air observations and Santa Fe surface data.

7. Lead emissions from incinerator and oil-fired asphalt heaters (the two combustion sources that continuously emit lead) were modeled using actual source parameters. Concentrations at the sensitive receptors were found 5 orders of magnitude lower than the NAAQS quarterly standard for lead of 1.5 micrograms per cubic meter.
8. Background concentrations were conservatively assumed to be 20 percent of the corresponding standard.

Results:

Nitrogen Dioxide Modeling Analysis for Combustion Sources at LANL

Initial modeling of NO_x concentrations resulted in a modeled 24-hour concentration of 519.76 micrograms per cubic meter (based on ISCST3 modeling). The applicable 24-hour standard, per New Mexico Ambient Air Quality Control Standards (AAQS) is 147 micrograms per cubic meters (adjusted for temperature and pressure [elevation]). Thus, based on the preliminary analysis, NO_x modeled concentrations are above the New Mexico AAQS. Therefore, the following methodology was used to evaluate the NO₂ concentrations.

New Mexico Air Quality Bureau—NO₂ Modeling Methodology. The Bureau has approved two screening techniques for estimating NO₂ concentrations from NO_x point sources. The first technique is a partial conversion rate of 40 percent, which is only applicable to 24-hour concentrations. Therefore, if the NO_x concentration is 200 micrograms per cubic meter, the NO₂ concentration can be assumed to be 80 micrograms per cubic meter. The second technique is that some sources will need to examine the atmospheric chemistry in a more rigorous manner. The guidance provides for using Ozone Limiting Method (OLM) to more accurately determine NO₂ concentrations. OLM should be used to resolve, if possible, any NO₂ standard exceedances at each receptor that shows a violation.

Modeling Analysis. Using this partial conversion rate of 40 percent, the acceptable 24-hour standard for LANL would be 368 micrograms per cubic meter [147 micrograms per cubic meter per 0.40] for NO_x. For the annual concentration analysis, no conversion was used, and the full modeled values were considered while comparing the results with the applicable ambient air standards.

All the receptors above the 24-hour threshold NO_x value of 368 micrograms per cubic meter were identified from the output table listing of 50-maximum 24-average concentration values. The resulting 50-maximum value table includes several header records identifying the concentration, date for the modeled concentration (ending hour of the averaging period), and the receptors (X and Y coordinates).

Based on the ISCST3 output file, there are only two 24-hour concentrations above 368 micrograms per cubic meter. To demonstrate compliance with the ambient air standard, OLM analysis was conducted for these two receptors.

Estimation of NO₂ Concentrations Resulting from NO_x Point Sources

- The first step is to use a screening technique (a standard Gaussian dispersion model [ISCST3]) to estimate the maximum NO_x concentrations.
- The second step involves estimating the fraction of this NO_x concentration occurring as NO₂.

Although NO₂ may be emitted directly to the atmosphere, most of it is formed as a result of reactions between NO and various other gases. The reaction with ozone is an effective means of converting NO to NO₂. In heavily polluted areas, reaction between NO and organic radicals provides an additional source of NO₂. A third source of NO₂ is the thermal conversion process:

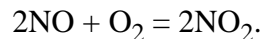

Ozone Limiting Method. The Ozone Limiting Method (OLM) involves an initial comparison of the estimated maximum NO_x concentration, (NO_x)_{max} and the ambient O₃ concentration to determine which is the limiting factor to NO₂ formation.

If the O₃ concentration is greater than (NO_x)_{max}, total conversion is assumed. If (NO_x)_{max} is greater than the O₃ concentration, the formation of NO₂ is limited by the ambient O₃ concentration.

The following expressions detail the procedure:

1. A standard dispersion model ISCST3 is used to calculate (NO_x)_{max}.
2. (NO_x)_{max} is separated into two components:
 - Thermal conversion portion. For combustion sources, this is estimated to be equal to 0.10(NO_x)_{max}.
 - The remaining NO subject to conversion by O₃ equal to 0.90 (NO_x)_{max}.
3. If (O₃)_{ambient} is greater than 0.90(NO_x)_{max}, then assume that all of the NO is converted to NO₂, i.e., (NO₂)_{max} = (NO_x)_{max}.

If 0.90(NO_x)_{max} is greater than (O₃)_{ambient}, then set (NO₂)_{max} = (O₃)_{ambient} + 0.10(NO_x)_{max}.

4. (NO₂)_{max} computed for the source is added to the NO₂ background.

The OLM program used for this analysis was BEE-LINE Software Inc., Version 2.5 (1995). In the OLM analysis, the default value for the NO₂ factor, micrograms per cubic meter to parts per million, is 1882.8091. This is one of the required input values by the OLM model. The corrected value (according to Bureau's Dispersion Modeling Guidelines) at an elevation of 7,000 feet is 1,473.4 micrograms per cubic meter, which was used in this OLM analysis.

Based on this OLM run, none of the receptors was found to exceed the NO₂ ambient air 24-hour standard of 147 micrograms per cubic meter. The maximum ozone corrected NO₂ value was only 90 micrograms per cubic meter. Therefore, maximum modeled NO₂ concentrations are below the applicable standards.

As shown in the following table, estimated criteria pollutant concentrations from combustion sources at LANL were within (i.e., less than) all national or State of New Mexico AAQS.

Results of Criteria Pollutants Analysis—Expanded Operations Alternative

POLLUTANT	TIME PERIOD	MAXIMUM ESTIMATED LANL IMPACTS ($\mu\text{g}/\text{m}^3$)	ASSUMED BACKGROUND CONCENTRATIONS ^a ($\mu\text{g}/\text{m}^3$)	TOTAL POLLUTANT CONCENTRATIONS ($\mu\text{g}/\text{m}^3$)	CONTROLLING AMBIENT AIR QUALITY STANDARDS ($\mu\text{g}/\text{m}^3$) ^b
Carbon Monoxide	1 hour	2,712	2,350	5,062	11,750
	8 hours	1,436	1,560	2,996	7,800
Nitrogen Dioxide ^c	24 hours	90 ^c	29	119	147
	Annual	9	15	24	74
Sulfur Dioxide	3 hours	254	205	459	1,025
	24 hours	130	41	171	205
	Annual	18	8	26	41
Total Suspended Particulates	24 hours	18	30	48	150
	Annual	2	12	14	60
PM ₁₀	24 hours	9	30	39	150
	Annual	1	10	11	50
Lead	3 months (calendar quarter)	0.7×10^{-4}	0.30	0.30	1.5

^a No data exists for background values. It was conservatively assumed that background concentrations were 20 percent of the corresponding standard. Because there are almost no other combustion sources in and around LANL, the background concentrations would be much less than the 20 percent assumed concentrations.

^b New Mexico Ambient Air Quality standards for some of the pollutants are stated in parts per million (ppm). These values were converted to micrograms per cubic meter ($\mu\text{g}/\text{m}^3$), with appropriate corrections for temperature and pressure (elevation) following New Mexico Dispersion Modeling Guidelines (revised January 1996).

^c New Mexico Air Quality Bureau accepts OLM to more accurately determine NO_2 concentrations. The 24-hour maximum modeled concentration for NO_x was $520 \mu\text{g}/\text{m}^3$. This concentration, when modeled using OLM, is only $90 \mu\text{g}/\text{m}^3$ for NO_2 .

Note: Ozone Analysis: Hourly ozone monitoring data from the BNM monitoring station for 1992 to 1994 were analyzed. The 1-hour of the fourth-highest values for the years 1992, 1993, and 1994 are 0.070 ppm, 0.066 ppm, and 0.072 ppm, respectively. The 3-year average of the annual fourth-highest maximum 1-hour concentration is 0.069 ppm. This value is about 58 percent of the 1-hour standard of 0.120 ppm. Therefore, DOE believes that when 8-hour data are analyzed in the future, these would show lower values than the new 8-hour standard of 0.08 ppm.

**TABLE A.—Peak Load Emission Rates Used for the Combustion Sources Analysis
(Boilers, Incinerator, and Natural Gas Fired Emergency Generators)**

SOURCE	FUEL	HEATING VALUE Btu/gal. (OR Btu/scf)	UNIT CAPACITY million Btu/hr (HP)	CO EF lb/10 ³ gal. (10 ⁶ ft ³) (OR lb/million scf)	CO ER g/sec	NO ₂ EF lb/10 ³ gal. (OR lb/million scf)	NO ₂ ER g/sec	SO ₂ EF lb/10 ³ gal. (OR lb/million scf)	SO ₂ ER g/sec	PM ₁₀ EF lb/10 ³ gal. (OR lb/million scf)	PM ₁₀ ER g/sec	TSP EF lb/10 ³ gal. (OR lb/million scf)	TSP ER g/sec
TA-3-22-1	oil #2	140,000	210	5	0.95	20	3.78	48	9.07	1.00	0.19	2	0.38
TA-21-357-1	oil #2	140,000	12	5	0.05	20	0.22	48	0.52	1.00	0.01	2	0.02
TA-16-4	nat. gas	1,050	4.29	0.01854	0.02	0.01854	0.02	0.0003	0.0003	0.006	0.01		0.01
TA-16-5	nat. gas	1,050	6.13	0.01854	0.03	0.01854	0.03	0.0003	0.0004	0.006	0.01		0.01
TA-16-6	nat. gas	1,050	7.60	0.01854	0.03	0.01854	0.03	0.0003	0.0005	0.006	0.01		0.01
TA-16-13	nat. gas	1,050	5.12	0.01854	0.02	0.01854	0.02	0.0003	0.0004	0.006	0.01		0.01
TA-16	nat. gas	1,050	26.53	0.01854	0.12	0.01854	0.12	0.0003	0.0019	0.006	0.038		0.038
Prototypical Misc. Boiler TA-15	nat. gas	1,050	11.13	21	0.03	100	0.13	0.6	0.001	12	0.02		0.02
Misc. Prototypical Boiler TA-18	nat. gas	1,050	4.18	21	0.01	100	0.05	0.6	0.0003	12	0.01		0.01
Misc. Prototypical Boiler TA-22	nat. gas	1,050	6.69	21	0.02	100	0.08	0.6	0.0005	12	0.01		0.01
Misc. Prototypical Boiler TA-33	nat. gas	1,050	3.00	21	0.01	100	0.04	0.6	0.0002	12	0.004		0.004
Misc. Prototypical Boiler TA-35	nat. gas	1,050	37.25	21	0.09	100	0.45	0.6	0.003	12	0.05		0.05
Misc. Prototypical Boiler TA-41	nat. gas	1,050	6.69	21	0.02	100	0.08	0.6	0.0005	12	0.01		0.01

TABLE A.—Peak Load Emission Rates Used for the Combustion Sources Analysis
(Boilers, Incinerator, and Natural Gas Fired Emergency Generators)—Continued

SOURCE	FUEL	HEATING VALUE Btu/gal. (OR Btu/scf)	UNIT CAPACITY million Btu/hr (HP)	CO EF lb/10 ³ gal. (10 ⁶ ft ³) (OR lb/million scf)	CO ER g/sec	NO ₂ EF lb/10 ³ gal. (OR lb/million scf)	NO ₂ ER g/sec	SO ₂ EF lb/10 ³ gal. (OR lb/million scf)	SO ₂ ER g/sec	PM ₁₀ EF lb/10 ³ gal. (OR lb/million scf)	PM ₁₀ ER g/sec	TSP EF lb/10 ³ gal. (OR lb/million scf)	TSP ER g/sec
Misc. Prototypical Boiler TA-46	nat. gas	1,050	5.47	21	0.01	100	0.07	0.6	0.0004	12	0.01		0.01
Misc. Prototypical Boiler TA-48	nat. gas	1,050	38.89	21	0.10	100	0.47	0.6	0.003	12	0.06		0.06
Misc. Prototypical Boiler TA-50	nat. gas	1,050	15.78	21	0.04	100	0.19	0.6	0.001	12	0.02		0.02
Misc. Prototypical Boiler TA-52	nat. gas	1,050	12.00	21	0.03	100	0.14	0.6	0.001	12	0.02		0.02
Misc. Prototypical Boiler TA-53	nat. gas	1,050	42.49	21	0.11	100	0.51	0.6	0.003	12	0.06		0.06
Misc. Prototypical Boiler TA-55	nat. gas	1,050	20.10	21	0.05	100	0.24	0.6	0.001	12	0.03		0.03
Misc. Prototypical Boiler TA-58	nat. gas	1,050	11.51	21	0.03	100	0.14	0.6	0.001	12	0.02		0.02
TA-3-73-1	nat. gas	1,050	10	21	0.025	100	0.12	0.6	0.001	12	0.014		0.014
TA-3-73-2	oil #2	140,000	10	5	0.05	20	0.18	48	0.43	1	0.01	2	0.02
Nat. Gas EG TA-3	nat. gas	1,050	0.15	21	0.0004	100	0.002	0.6	0.00001	12	0.0002		0.0002
Nat. Gas EG TA-16	nat. gas	1,050	0.25	21	0.001	100	0.003	0.6	0.00002	12	0.0004		0.0004
Nat. Gas EG TA-35	nat. gas	1,050	0.20	21	0.001	100	0.002	0.6	0.00001	12	0.0003		0.0003

**TABLE A.—Peak Load Emission Rates Used for the Combustion Sources Analysis
(Boilers, Incinerator, and Natural Gas Fired Emergency Generators)-Continued**

SOURCE	FUEL	HEATING VALUE Btu/gal. (OR Btu/scf)	UNIT CAPACITY million Btu/hr (HP)	CO EF lb/10 ³ gal. (10 ⁶ ft ³) (OR lb/million scf)	CO ER g/sec	NO ₂ EF lb/10 ³ gal. (OR lb/million scf)	NO ₂ ER g/sec	SO ₂ EF lb/10 ³ gal. (OR lb/million scf)	SO ₂ ER g/sec	PM ₁₀ EF lb/10 ³ gal. (OR lb/million scf)	PM ₁₀ ER g/sec	TSP EF lb/10 ³ gal. (OR lb/million scf)	TSP ER g/sec
Nat.Gas EG TA-50	nat. gas	1,050	0.20	21	0.001	100	0.002	0.6	0.00001	12	0.0003		0.0003
Nat. Gas EG TA-53	nat. gas	1,050	0.25	21	0.001	100	0.003	0.6	0.00002	12	0.0004		0.0004
Nat. Gas Water Pump	nat. gas	1,050	700	1.60	0.311	5	0.972	0	0.000	0.003	0.001		0.001
Incinerator	waste				0.015		0.007		0.055		0.007		0.007

Notes:

- TA-16 emission factors in tons/MMSCF for the low NO_x boilers were provided by boiler manufacturer (Sellers Engineering Co., Danville, Kentucky, July 1995).
 - TA-16 prototypical boiler unit capacity is a total capacity of all TA-16 boilers, except replacement (package) boilers, which were modeled separately.
 - Miscellaneous prototypical boiler output capacity is a total capacity of boilers at each TA. Unit capacity is obtained from output capacity using the boiler efficiency of 72%.
 - All miscellaneous boilers and replacement boilers at TA-16 are natural gas fired (Title V application) (LANL 1995b).
 - Water pump engine has capacity of 700 hp, emission factors for water pump are in g/hp-hr.
 - According to AP-42 (EPA 1995) particulate matter from the natural gas combustion is less than 1 μm in size, so ER(PM₁₀) = ER(TSP).
 - TSP EF from the fuel oil #2 is the same as in Title V application (LANL 1995b); PM₁₀ EF is obtained from Table 1.3-5 for size-specific EF from industrial boilers (EPA 1995).
 - Waste oil and solid waste are burned. 8-hour CO and 24-hour SO₂ concentrations were conservatively estimated with 1-hour (CO) and 3-hours (SO₂) average emission rates.
 - The second stacks at steam plants at TA-3 and TA-21 are used for standby or emergency operations only and were not taken into account (LANL 1995b).
- EF = Emission Factor, EG = Emergency Generators, ER = Emission Rate, HP = horse power, SCF = standard cubic foot, TSP = Total Suspended Particulates

**TABLE B.—Peak Load Emission Rates Used for the Combustion Sources Analysis
(Diesel and Gasoline Fired Emergency Generators)^d**

SOURCE ^{a,b}	FUEL	HEATING VALUE Btu/gal. (OR Btu/ scf)	DESIGN CAPACITY kw	CO EF g/kw-hr	CO ER g/sec	NO ₂ EF g/kw-hr	NO ₂ ER g/sec	SO ₂ EF g/kw-hr	SO ₂ ER g/sec	PM ₁₀ EF ^c g/kw-hr (OR lb/ million Btu)	PM ₁₀ ER g/sec	TSP EF g/kw-hr (OR lb/ million Btu)	TSP ER g/sec
Diesel EG TA-3	diesel	137,000	1344.97	4.06	1.52	18.8	7.02	1.25	0.47	1.34	0.50	2.68	1.00
Diesel EG TA-3*	diesel	137,000	1100	3.2	0.98	14	4.28		0.00	0.0573	0.027	0.0697	0.033
Diesel EG TA-8	diesel	137,000	59.66	4.06	0.07	18.8	0.31	1.25	0.02	1.34	0.02	2.68	0.04
Diesel EG TA-15	diesel	137,000	19.39	4.06	0.02	18.8	0.10	1.25	0.01	1.34	0.01	2.68	0.01
Diesel EG TA-16	diesel	137,000	250	4.06	0.28	18.8	1.31	1.25	0.09	1.34	0.09	2.68	0.19
Diesel EG TA-18	diesel	137,000	286.93	4.06	0.32	18.8	1.50	1.25	0.10	1.34	0.11	2.68	0.21
Diesel EG TA-21*	diesel	137,000	750	3.2	0.67	14	2.92		0.00	0.0573	0.018	0.0697	0.022
Diesel EG TA-21	diesel	137,000	140.19	4.06	0.16	18.8	0.73	1.25	0.05	1.34	0.05	2.68	0.10
Diesel EG TA-33	diesel	137,000	59.66	4.06	0.07	18.8	0.31	1.25	0.02	1.34	0.02	2.68	0.04
Diesel EG TA-35	diesel	137,000	79.79	4.06	0.09	18.8	0.42	1.25	0.03	1.34	0.03	2.68	0.06
Diesel EG TA-41	diesel	137,000	150	4.06	0.17	18.8	0.78	1.25	0.05	1.34	0.06	2.68	0.11
Diesel EG TA-43	diesel	137,000	150	4.06	0.17	18.8	0.78	1.25	0.05	1.34	0.06	2.68	0.11
Diesel EG TA-46	diesel	137,000	300	4.06	0.34	18.8	1.57	1.25	0.10	1.34	0.11	2.68	0.22
Diesel EG TA-50*	diesel	137,000	1,700	3.2	1.51	14	6.61		0.00	0.0573	0.042	0.0697	0.051

**TABLE B.—Peak Load Emission Rates Used for the Combustion Sources Analysis
(Diesel and Gasoline Fired Emergency Generators)^d-Continued**

SOURCE ^{a,b}	FUEL	HEATING VALUE Btu/gal. (OR Btu/scf)	DESIGN CAPACITY kw	CO EF g/kw-hr	CO ER g/sec	NO ₂ EF g/kw-hr	NO ₂ ER g/sec	SO ₂ EF g/kw-hr	SO ₂ ER g/sec	PM ₁₀ EF ^c g/kw-hr (OR lb/million Btu)	PM ₁₀ ER g/sec	TSP EF g/kw-hr (OR lb/million Btu)	TSP ER g/sec
Diesel EG TA-53	diesel	137,000	59.66	4.06	0.07	18.8	0.31	1.25	0.02	1.34	0.02	2.68	0.04
Diesel EG TA-55*	diesel	137,000	600	3.2	0.53	14	2.33		0.00	0.0573	0.015	0.0697	0.018
Diesel EG TA-55	diesel	137,000	200	4.06	0.23	18.8	1.04	1.25	0.07	1.34	0.07	2.68	0.15
Diesel EG TA-59	diesel	137,000	238.62	4.06	0.27	18.8	1.25	1.25	0.08	1.34	0.09	2.68	0.18
Diesel EG TA-61	diesel	137,000	35.05	4.06	0.04	18.8	0.18	1.25	0.01	1.34	0.01	2.68	0.03
Diesel EG TA-64	diesel	137,000	264.91	4.06	0.30	18.8	1.38	1.25	0.09	1.34	0.10	2.68	0.20
Diesel EG 6th Str.	diesel	137,000	300	4.06	0.34	18.8	1.57	1.25	0.10	1.34	0.11	2.68	0.22
Diesel EG Rover	diesel	137,000	80.54	4.06	0.09	18.8	0.42	1.25	0.03	1.34	0.03	2.68	0.06
Gasoline EG TA-3	gasoline	130,000	181.95	267	13.49	6.92	0.35	0.359	0.02	0.439	0.02	0.878	0.04
Gasoline EG TA-8	gasoline	130,000	46.98	267	3.48	6.92	0.09	0.359	0.005	0.439	0.01	0.878	0.01
Gasoline EG TA-15	gasoline	130,000	0.75	267	0.06	6.92	0.001	0.359	0.0001	0.439	0.0001	0.878	0.0002
Gasoline EG TA-16	gasoline	130,000	10.44	267	0.77	6.92	0.02	0.359	0.001	0.439	0.001	0.878	0.003
Gasoline EG TA-21	gasoline	130,000	10.44	267	0.77	6.92	0.02	0.359	0.001	0.439	0.001	0.878	0.003
Gasoline EG TA-39	gasoline	130,000	2.24	267	0.17	6.92	0.004	0.359	0.0002	0.439	0.0003	0.878	0.0005

**TABLE B.—Peak Load Emission Rates Used for the Combustion Sources Analysis
(Diesel and Gasoline Fired Emergency Generators)^d-Continued**

SOURCE ^{a,b}	FUEL	HEATING VALUE Btu/gal. (OR Btu/scf)	DESIGN CAPACITY kw	CO EF g/kw-hr	CO ER g/sec	NO ₂ EF g/kw-hr	NO ₂ ER g/sec	SO ₂ EF g/kw-hr	SO ₂ ER g/sec	PM ₁₀ EF ^c g/kw-hr (OR lb/million Btu)	PM ₁₀ ER g/sec	TSP EF g/kw-hr (OR lb/million Btu)	TSP ER g/sec
Gasoline EG TA-46	gasoline	130,000	8.95	267	0.66	6.92	0.02	0.359	0.001	0.439	0.001	0.878	0.002
Gasoline EG TA-49	gasoline	130,000	5.97	267	0.44	6.92	0.01	0.359	0.001	0.439	0.001	0.878	0.001
Gasoline EG TA-50	gasoline	130,000	32.07	267	2.38	6.92	0.06	0.359	0.003	0.439	0.004	0.878	0.008
Gasoline EG TA-53	gasoline	130,000	49.96	267	3.71	6.92	0.10	0.359	0.005	0.439	0.01	0.878	0.01
Gasoline EG TA-54	gasoline	130,000	27.59	267	2.05	6.92	0.05	0.359	0.003	0.439	0.003	0.878	0.007
Gasoline EG TA-55	gasoline	130,000	3.73	267	0.28	6.92	0.01	0.359	0.0004	0.439	0.0005	0.878	0.0009
Gasoline EG TA-59	gasoline	130,000	11.19	267	0.83	6.92	0.02	0.359	0.001	0.439	0.001	0.878	0.003
Gasoline EG TA-63	gasoline	130,000	21.63	267	1.60	6.92	0.04	0.359	0.002	0.439	0.003	0.878	0.005
Gasoline EG TA-64	gasoline	130,000	26.10	267	1.94	6.92	0.05	0.359	0.003	0.439	0.003	0.878	0.006

Notes:

- ^a All emergency generators design capacities at a particular TA are total capacity of all of the same fuel fired generators.
- ^b Emission factors for the diesel fired generators differ depending on the size of the generator; industrial generators are those with capacity up to 457 kW (600 hp) generators above this limit are considered large stationary diesel engines (in the table they are marked with an asterisk). If industrial generators are in the same TA as smaller generators, ER for industrial generators are presented separately.
- ^c Particulate emissions for gasoline fueled generators and small industrial generators in size distribution were not available. It was assumed that ER(TSP) = 2 x ER(PM₁₀).
- ^d Insignificant sources like small movable generators or TA-57 emergency generators were not included in this analysis. Emissions from Rover Street PA40 generator and 6th Street Cummins generator were added to the TA-3 diesel generator emissions.

TABLE C.—Annual Average Emission Rates Used for the Combustion Source Analysis

SOURCE ^d	FUEL	FUEL USAGE (million cf/yr) (OR gal./yr)	CO EF lb/10 ³ gal. (OR lb/ million scf)	CO ER ^c g/sec	NO ₂ EF lb/ 10 ³ gal. (OR lb/ million scf)	NO ₂ ER g/sec	SO ₂ EF lb/10 ³ gal. (OR lb/ million scf)	SO ₂ ER ^c g/sec	PM ₁₀ EF ^a lb/10 ³ gal. (OR lb/ million scf)	PM ₁₀ ER g/sec	TSP EF ^b lb/10 ³ gal. (OR lb/ million scf)	TSP ER g/sec
TA-3-22-1	nat. gas	1,500	40	0.86	163	3.52	0.6	0.01	5	0.11	5	0.11
TA-21-357-1	nat. gas	82	35	0.04	140	0.17	0.6	0.001	5	0.01	5	0.01
TA-16-4	nat. gas	45.56	0.01854	0.02	0.01854	0.02	0.0003	0.0004	0.006	0.01	0.006	0.01
TA-16-5	nat. gas	65.13	0.01854	0.03	0.01854	0.03	0.0003	0.001	0.006	0.01	0.006	0.01
TA-16-6	nat. gas	80.8	0.01854	0.04	0.01854	0.04	0.0003	0.001	0.006	0.01	0.006	0.01
TA-16-13	nat. gas	54.46	0.01854	0.03	0.01854	0.03	0.0003	0.0005	0.006	0.01	0.006	0.01
TA-16 Prototypical	nat. gas	294.23	0.01854	0.16	0.01854	0.16	0.0003	0.003	0.006	0.05	0.006	0.05
Misc. Prototypical Boiler TA-15	nat. gas	40.9	21	0.01	100	0.06	0.6	0.0004	12	0.01	12	0.01
Misc. Prototypical Boiler TA-18	nat. gas	15.88	21	0.005	100	0.02	0.6	0.0001	12	0.003	12	0.003
Misc. Prototypical Boiler TA-22	nat. gas	25.4	21	0.01	100	0.04	0.6	0.0002	12	0.004	12	0.004
Misc. Prototypical Boiler TA-33	nat. gas	11.38	21	0.003	100	0.02	0.6	0.0001	12	0.002	12	0.002
Misc. Prototypical Boiler TA-35	nat. gas	116.94	21	0.04	100	0.17	0.6	0.001	12	0.02	12	0.02
Misc. Prototypical Boiler TA-41	nat. gas	19.02	21	0.01	100	0.03	0.6	0.0002	12	0.003	12	0.003
Misc. Prototypical Boiler TA-46	nat. gas	15.55	21	0.005	100	0.02	0.6	0.0001	12	0.003	12	0.003

TABLE C.—Annual Average Emission Rates Used for the Combustion Source Analysis-Continued

SOURCE ^d	FUEL	FUEL USAGE (million cf/yr) (OR gal./yr)	CO EF lb/10 ³ gal. (OR lb/ million scf)	CO ER ^c g/sec	NO ₂ EF lb/ 10 ³ gal. (OR lb/ million scf)	NO ₂ ER g/sec	SO ₂ EF lb/10 ³ gal. (OR lb/ million scf)	SO ₂ ER ^c g/sec	PM ₁₀ EF ^a lb/10 ³ gal. (OR lb/ million scf)	PM ₁₀ ER g/sec	TSP EF ^b lb/10 ³ gal. (OR lb/ million scf)	TSP ER g/sec
Misc. Prototypical Boiler TA-48	nat. gas	103.44	21	0.03	100	0.15	0.6	0.001	12	0.02	12	0.02
Misc. Prototypical Boiler TA-50	nat. gas	21.56	21	0.01	100	0.03	0.6	0.0002	12	0.004	12	0.004
Misc. Prototypical Boiler TA-52	nat. gas	28.69	21	0.01	100	0.04	0.6	0.0002	12	0.005	12	0.005
Misc. Prototypical Boiler TA-53	nat. gas	95.68	21	0.03	100	0.14	0.6	0.001	12	0.02	12	0.02
Misc. Prototypical Boiler TA-55	nat. gas	48.28	21	0.01	100	0.07	0.6	0.0004	12	0.01	12	0.01
Misc. Prototypical Boiler TA-58	nat. gas	28.05	21	0.01	100	0.04	0.6	0.0002	12	0.005	12	0.005
TA-3-73-1	nat. gas	13.6	21	0.004	100	0.02	0.6	0.0001	12	0.002	12	0.002
TA-3-73-2	oil #2	7,000	5	0.001	20	0.002	48	0.005	2	0.0002	2	0.0002
Nat. Gas Water Pump	nat. gas	700	1.6	0.31	5	0.97	0	0.00	0.003	0.001	0.003	0.001
Incinerator	waste			0.00002		0.0002		0.0002		0.0002		0.0002

Notes:

^a According to AP-42 (EPA 1995), particulate matter from the natural gas combustion is less than 1 μm in size, so ER(PM₁₀) = ER(TSP).

^b TSP EF from the fuel oil #2 is the same as in Title V application; PM₁₀ EF is obtained from Table 1.3-5 for size-specific EF from industrial boilers (EPA 1995).

^c Waste oil and solid waste was burned. 8-hour CO and 24-hour SO₂ concentrations were conservatively estimated using 1-hour (CO) and 3-hours (SO₂) emission rates.

^d In the first column, a miscellaneous prototypical boiler is a boiler that sums up emissions from all boilers at this TA.

ATTACHMENT 2
TOXIC CHEMICALS CONSIDERED FOR THE ANALYSIS

**Toxic Chemicals Considered for the
Analysis**

NO.	TOXIC AIR POLLUTANTS
NONCARCINOGENIC POLLUTANTS	
1	1,1-Dichloroethane
2	1,1,2-Trichloro-1,2,2-Trifluoroethane
3	1,1-Dichloro-Nitroethane
4	1,4-Dioxane
5	1,1,1-Trichloroethane
6	1,2,4-Trimethylbenzene
7	1,2-Dichloroethylene
8	1,3,5-Trimethylbenzene
9	1-Chloro-1-Nitropropane
10	1-Nitropropane
11	2,4,6-Trinitrotoluene (TNT)
12	2-Aminopyridine
13	2-Butoxyethanol
14	2-Butoxyethanol Acetate
15	2-Diethylaminoethanol
16	2-Ethoxyethanol (EGEE)
17	2-Ethoxyethyl Acetate (EGEEA)
18	2-Hydroxypropyl Acrylate
19	2-Methoxyethanol (EGME)
20	2-Methoxyethyl Acetate
21	2-Methyl-Cyclopent. Mang. Tricarbonyl
22	4-Methoxyphenol
23	a-Methyl Styrene
24	Acetic Acid
25	Acetic Anhydride
26	Acetone
27	Acetonitrile
28	Acetophenone
29	Acetylene
30	Acetylene Tetrabromide

**Toxic Chemicals Considered for the
Analysis-Continued**

NO.	TOXIC AIR POLLUTANTS
31	Acrolein
32	Acrylic Acid
33	Adiponitrile
34	Allyl Alcohol
35	Allyl Glycidyl Ether (AGE)
36	Aluminum, Metal Dust, as Al
37	Aluminum Alkyls not otherwise classified
38	Aluminum Pyro Powders, as Al
39	Aluminum, Welding Fumes, as Al
40	Amitrole
41	Ammonia
42	Ammonium Chloride (Fume)
43	Aniline and Homologues
44	Anisidine (o-, p-isomers)
45	Antimony and Compounds, as Sb
46	Arsine
47	Asphalt (Petroleum) Fumes
48	Benzenethiol
49	Benzoyl Peroxide
50	Biphenyl
51	Bismuth Telluride
52	Boron Oxide
53	Boron Trifluoride
54	Bromine
55	Bromine Pentafluoride
56	Bromoform
57	Butyl Mercaptan
58	Carbon Black
59	Carbon Disulfide
60	Carbon Tetrabromide
61	Catechol
62	Cesium Hydroxide

**Toxic Chemicals Considered for the
Analysis-Continued**

NO.	TOXIC AIR POLLUTANTS
63	Chlorinated Camphene
64	Chlorine
65	Chlorine Trifluoride
66	Chloroacetaldehyde
67	Chloroacetyl Chloride
68	Chlorobenzene
69	Chlorodifluoromethane
70	Chromium III comp., as Cr
71	Cobalt Carbonyl, as Co
72	Cobalt Hydrocarbonyl, as Co
73	Cobalt, el. & inorg. comp., as Co
74	Copper, Dusts & Mists, as Cu
75	Copper, Fume, as Cu
76	Cresol (all isomers)
77	Crotonaldehyde
78	Cumene
79	Cyanamide
80	Cyanogen
81	Cyanogen Chloride
82	Cyclohexane
83	Cyclohexanol
84	Cyclohexanone
85	Cyclohexene
86	Cyclohexylamine
87	Cyclopentadiene
88	Cyclopentane
89	Decaborane
90	Di-sec, Octyl Phthalate
91	Diacetone Alcohol
92	Diazinon
93	Diazomethane
94	Dibutyl Phosphate

**Toxic Chemicals Considered for the
Analysis-Continued**

NO.	TOXIC AIR POLLUTANTS
95	Dibutyl Phthalate
96	Dichlorodifluoromethane
97	Dichlorofluoromethane
98	Dichlorovos
99	Dicyclopentadiene
100	Dicyclopentadienyl Iron
101	Diethyl Ketone
102	Diethyl Phthalate
103	Diethylamine
104	Diethylene Triamine
105	Diisopropylamine
106	Dimethoxymethane
107	Dimethyl Amine
108	Dimethyl Phthalate
109	Dimethyl Sulfate
110	Dinitro-o-Cresol
111	Dinitrobenzene (all isomers)
112	Dinitrotoluene
113	Diphenylamine
114	Dipropyl Ketone
115	Diprop. Glycol Methyl Ether
116	Divinyl Benzene
117	Endrin
118	Enflurane
119	Ethanol
120	Ethanolamine
121	Ethion
122	Ethyl Acetate
123	Ethyl Benzene
124	Ethyl Bromide
125	Ethyl Chloride
126	Ethyl Ether

**Toxic Chemicals Considered for the
Analysis-Continued**

NO.	TOXIC AIR POLLUTANTS
127	Ethyl Formate
128	Ethyl Mercaptan
129	Ethylamine
130	Ethylene Chlorohydrin
131	Ethylene Diamine
132	Fibrous Glass Dust
133	Fluorides, as F
134	Fluorine
135	Formamide
136	Formic Acid
137	Furfural
138	Furfuryl Alcohol
139	Gasoline
140	Germanium Tetrahydride
141	Glutaraldehyde
142	Hafnium
143	Hexafluoroacetone
144	Hexamethylene Diisocyanate
145	Hexane (other isomers)*
146	Hexylene Glycol
147	Hydrogen Bromide
148	Hydrogen Chloride
149	Hydrogen Cyanide
150	Hydrogen Fluoride, as F
151	Hydrogen Peroxide
152	Hydrogen Sulfide
153	Hydroquinone
154	Indene
155	Indium & compounds, as In
156	Iodine
157	Iodoform
158	Iron Oxide Fume, as Fe

**Toxic Chemicals Considered for the
Analysis-Continued**

NO.	TOXIC AIR POLLUTANTS
159	Iron Pentacarbonyl, as Fe
160	Iso-Amyl Acetate
161	Iso-Amyl Alcohol
162	Isobutane
163	Isobutyl Acetate
164	Isobutyl Alcohol
165	Isobutyronitrile
166	Isooctyl Alcohol
167	Isophorone
168	Isophorone Diisocyanate
169	Isopropoxyethanol
170	Isopropyl Acetate
171	Isopropyl Alcohol
172	Isopropyl Ether
173	Isopropylamine
174	Kerosene
175	Lead, el. & inorg. compounds, as Pb
176	Lithium Hydride
177	m-Cresol
178	m-Phenylenediamine
179	m-Toluidine
180	Magnesium Oxide Fume
181	Maleic Anhydride
182	Malononitrile
183	Manganese Comp., as Mn
184	Manganese as Mn Fume
185	Mercury (in. forms, incl. m.Hg)
186	Mercury Alkyl Compounds
187	Mercury Aryl Compounds
188	Methacrylic Acid
189	Methoxychlor
190	Methyl 2-Cyanoacrylate

**Toxic Chemicals Considered for the
Analysis-Continued**

NO.	TOXIC AIR POLLUTANTS
191	Methyl Acetate
192	Methyl Acetylene
193	Methyl Acrylate
194	Methyl Alcohol
195	Methyl Cyclohexane
196	Methyl Ethyl Ketone (MEK)
197	Methyl Formate
198	Methyl Hydrazine
199	Methyl Iodide
200	Methyl Isobutyl Carbinol
201	Methyl Isobutyl Ketone
202	Methyl Isocyanate
203	Methyl Mercaptan
204	Methyl Methacrylate
205	Methyl n-Amyl Ketone
206	Methyl n-Butyl Ketone
207	Methyl Propyl Ketone
208	Methyl Silicate
209	Methylacrylonitrile
210	Methylamine
211	Methylene Bisphenyl Isocyanate
212	Molybdenum as Mo Insol. Comp.
213	Molybdenum as Mo Sol. Comp.
214	Morpholine
215	n,n-Dimethyl Acetamide
216	n,n-Dimethylaniline
217	n,n-Dimethylformamide
218	n-Amyl Acetate
219	n-Butyl Acetate
220	n-Butyl Acrylate
221	n-Butyl Alcohol
222	n-Butyl Glycidyl Ether (BGE)

**Toxic Chemicals Considered for the
Analysis-Continued**

NO.	TOXIC AIR POLLUTANTS
223	n-Butylamine
224	n-Heptane
225	n-Hexane
226	n-Methylaniline
227	n-Propyl Acetate
228	Naphtalene
229	Nickel Carbonyl, as Ni
230	Nickel Sol. & In. Comp., as Ni
231	Nicotine
232	Nitric Acid
233	Nitric Oxide
234	Nitrobenzene
235	Nitroethane
236	Nitromethane
237	Nitrotoluene
238	Nitrous Oxide
239	Nonane
240	o-Chlorostyrene
241	o-Chlorotoluene
242	o-Dichlorobenzene
243	o-Methylcyclohexanone
244	o-Phenylenediamine
245	o-Toluidine
246	Octane
247	Oil Mist, Mineral
248	Osmium Tetroxide, as Os
249	Oxalic Acid
250	p-Nitroaniline
251	p-Nitrochlorobenzene
252	p-Phenylenediamine
253	p-Toluidine
254	Paraffin Wax Fume

**Toxic Chemicals Considered for the
Analysis-Continued**

NO.	TOXIC AIR POLLUTANTS
255	Paraquat Dichloride
256	Paraquat Respirable Sizes
257	Particulate Matter, Resp. Dust
258	Pentachlorophenol
259	Pentaerythritol
260	Pentane (all isomers)
261	Perchloromethyl Mercaptan
262	Phenol
263	Phenothiazine
264	Phenylhydrazine
265	Phenylphosphine
266	Phosgene
267	Phosphoric Acid
268	Phosphorus
269	Phosphorus Oxychloride
270	Phosphorus Pentachloride
271	Phosphorus Trichloride
272	Picric Acid
273	Platinum Metal
274	Potassium Hydroxide
275	Propane
276	Propargyl Alcohol
277	Propionic Acid
278	Propionitrile
239	Propyl Alcohol
280	Propylene Glycol Monomethyl Ether
281	Pyridine
282	Rhodium Metal
283	sec-Butyl Acetate
284	sec-Butyl Alcohol
285	Selenium Compounds, as Se
286	Silica, Cristobalite

**Toxic Chemicals Considered for the
Analysis-Continued**

NO.	TOXIC AIR POLLUTANTS
287	Silica, Quartz
288	Tridymite, Respirable Dust
289	Silica, Fused (respirable)
290	Silicon Tetrahydride
291	Silver (met. dust & sol. comp., as Ag)
292	Stoddard Solvent
293	Sulfur Hexafluoride
294	Sulfuric Acid
295	Sulfuryl Fluoride
296	Tantalum Metal
297	Tellurium & Compounds, as Te
298	Terphenyls
299	tert-Butyl Alcohol
300	Tetraethyl Lead
301	Tetrahydrofuran
302	Tetranitromethane
303	Tetrasodium Pyrophosphate
304	Thioglycolic Acid
305	Thionyl Chloride
306	Tin, metal
307	Tin Organic Compounds, as Sn
308	Tin Oxide & Inorg. Comp., as Sn
309	Toluene
310	Toluene-2,4-diisocyanate (TDI)
311	Tributyl Phosphate
312	Trichloroacetic Acid
313	Triethylamine
314	Trimethyl Benzene
315	Trimethyl Phosphite
316	Trimethylamine
317	Triphenylamine
318	Triphenylphosphate

**Toxic Chemicals Considered for the
Analysis-Continued**

NO.	TOXIC AIR POLLUTANTS
319	Tungsten as W insoluble Compounds
320	Turpentine
321	Uranium (nat.) Sol. & Unsol. Comp. as U
322	Vanadium, Respirable Dust & Fume
323	Vinyl Acetate
324	Vinyl Toluene
325	Vinylidene Fluoride
326	VM & P Naphtha
327	Welding Fumes not otherwise listed
328	Wood Dust (certain hard woods)
329	Xylene (o-, m-, p-Isomers)
330	Yttrium
331	Zinc Chloride Fume
332	Zinc Oxide Fume
333	Zinc Chromate, as Cr
334	Zirconium Compounds, as Zr
CARCINOGENIC POLLUTANTS	
335	Acetaldehyde
336	Acrylamide
337	Acrylonitrile
338	Allyl Chloride
339	Aldrin
340	Arsenic, el. & inorg., exc. Arsine, as As
341	Asbestos
342	Benzene
343	Benzidine
344	Benzo(a)pyrene
345	Benzyl Chloride
346	Beryllium
347	Bis(Chloromethyl)Ether (BCME)
348	1,3-Butadiene

**Toxic Chemicals Considered for the
Analysis-Continued**

NO.	TOXIC AIR POLLUTANTS
349	Cadmium, el. & compounds, as Cd
350	Carbon Tetrachloride
351	Chloroform
352	Chlordane
353	Chromium VI
354	Diethanolamine
355	3,3-Dichlorobenzidine
356	Epichlorohydrin
357	Ethyl Acrylate
358	Ethylene Dibromide
359	Ethylene Dichloride
360	Ethylene Oxide
361	Formaldehyde
362	Hexachlorobenzene
363	Hexachlorobutadiene
364	Hexachloroethane
365	Hydrazine
366	Lindane
367	Methyl Chloride
368	Methylene Chloride
369	Nickel, metal (dust)
370	Polychlorinated Biphenyl (PCB)
371	Propylene Dichloride
372	Propylene Oxide
373	Styrene
374	Tetrachlorethylene
375	Trichloroethylene
376	Vinyl Chloride
377	1,1-Dichloethylene
378	1,1,2,2-Tetrachloroethane
379	1,1,1,2-Tetrachloroethane

***Toxic Chemicals Considered for the
Analysis-Continued***

NO.	TOXIC AIR POLLUTANTS
380	1,1,2-Trichloroethane
381	1,2-Dibromo-3-Chloropropane
382	2-Nitropropane

**ATTACHMENT 3
SET OF SENSITIVE RECEPTORS FOR
NONRADIOLOGICAL AIR QUALITY ANALYSIS**

*Set of Sensitive Receptors for Nonradiological
Air Quality Analysis*

RECEPTOR ID	RECEPTOR NAME
1	Entrance Park
2	Airport
3	East Park
4	Sombrillo Facility
5	Canyon School Park
6	Canyon Elementary School
7	Furr's Supermarket
8	Canyon Road Park
9	Pine Street Playlot
10	YMCA
11	Post Office
12	Community Shopping Center
13	Community Center Park
14	Masonic Temple
15	Unitarian Fellowship Church and Sage Montessori School
16	Church of Latter Day Saints
17	Fuller Lodge and Park
18	Ashley Pond
19	Mesa Public Library
20	Senior Center
21	United Church of Los Alamos and Canyoncito Montessori School
22	Jewish Center
23	Orange Street Playlot
24	Larry Walkup Aquatic Center
25	Immaculate Heart of Mary Catholic Church
26	Los Alamos High School
27	Episcopal Church
28	Los Alamos Medical Center
29	Methodist Church and ARK Daycare Center
30	Sullivan Field
31	Mesa Complex
32	Ed's Food Market
33	Western Area Park

*Set of Sensitive Receptors for Nonradiological
Air Quality Analysis-Continued*

RECEPTOR ID	RECEPTOR NAME
34	Ridgeway Playlot
35	Pueblo Complex
36	37 th Street Playlot
37	Aspen Elementary School
38	Walnut Street Playlot
39	Urban Park
40	Mountain School
41	Church of Christ
42	Fantasy Playlot
43	Golf Course
44	Guaje Pines Cemetery
45	Park
46	Picnic Area
47	Los Alamos Middle School
48	North Mesa Picnic Grounds
49	Rodeo Arena
50	Playlot
51	Barranca School
52	Barranca Mesa Park
53	Park
54	Overlook Park
55	Chamisa Elementary School
56	Mountain Meadow Playlot
57	Teddy Bear Junction
58	WR Shopping Center
59	Piñon Park
60	Piñon Elementary School
61	Grand Canyon Park
62	Jeffrey Playlot
63	Rover Park
64	Sage Montessori School
65	Park
66	Park
67	Community Club
68	Park
69	Park
70	Park

**Set of Sensitive Receptors for Nonradiological
Air Quality Analysis-Continued**

RECEPTOR ID	RECEPTOR NAME
71	First Baptist Church and Busy Bee Daycare and Playschool
72	Little Forest Daycare
73	North Mesa Ballfields
74	36 th Street Tennis Courts
75	Covenant Christian School
76	Hilltop Christian Academy
77	Los Alamos Sportman's Club
78	Royal Crest RV and Mobile Home Park
79	Camp May
80	Pajarito Ski Area
81	Los Alamos Reservoir
82	Duchess Castle Ruins
83	Tsankawi Ruins
84	Mortandad Cave
85	Otowi Ruins
86	Puye Cliffs
87	Two-Mile Mesa Trail
88	LANL Fitness Trail
89	Cuba
90	Jemez Springs
91	Coyote
92	Abiquiu
93	Chimayo
94	San Ysidro
95	Bernalillo
96	Corrales
97	Cedar Crest
98	Golden
99	Madrid
100	Lamy
101	Village of Agua Fria
102	Santa Fe
103	Tesuque
104	Española
105	Santa Cruz

**Set of Sensitive Receptors for Nonradiological
Air Quality Analysis-Continued**

RECEPTOR ID	RECEPTOR NAME
106	El Rancho
107	Jaconita
108	Pojoaque
109	Nambe
110	Cuyamungue
111	Eldorado
112	Gallina
113	Alcalde
114	Ojo Caliente
115	Dixon
116	Taos
117	Picuris Pueblo
118	Nambe Pueblo
119	Tesuque Pueblo
120	Santa Clara Pueblo
121	San Juan Pueblo
122	San Ildefonso Pueblo
123	Cochiti Pueblo
124	San Felipe Pueblo
125	Santa Ana Pueblo
126	Jemez Pueblo
127	Jemez Pueblo
128	Jemez Pueblo
129	Sandia Pueblo
130	Taos Pueblo
131	Jicarilla Apache Indian Reservation
132	Acoma Pueblo
133	Isleta Pueblo
134	Mescalero Apaches
135	Abiquiu Lake
136	Cochiti Lake
137	Fenton Lake
138	Las Cumbres Learning Services
139	Zia Pueblo
140	Zia Pueblo
141	Zia Pueblo
142	Bandelier National Monument

*Set of Sensitive Receptors for Nonradiological
Air Quality Analysis-Continued*

RECEPTOR ID	RECEPTOR NAME
143	Santo Domingo Pueblo
144	Crownpoint Navajo Indian Reservation
145	Taos Pueblo
146	Taos Pueblo
147	Trail on North Side of White Rock
148	White Rock Canyon Rim Trail
149	Red Dot Trail
150	Trail on West Side of Pajarito Acres
151	Trail on East Side of LANL
152	Trail on East Side of LANL
153	Fey Trail
154	Trail West of Frey Trail
155	Lower Frijoles Canyon Trail
156	Trail on North Side of Bandelier National Monument
157	North Side of Bandelier National Monument
158	Burnt Mesa Trail
159	Burnt Mesa Trail
160	Trail South of Burnt Mesa Trail
161	Burnt Mesa Trail
162	Burnt Mesa Trail
163	Burnt Mesa Trail
164	Upper Frijoles Crossing Trail
165	Water Canyon Trail 281
166	Canyon de Valle Trail
167	Trail South of Pajarito Canyon Trail 280
168	Nature Loop
169	Pueblo Canyon Trail
170	Pueblo Canyon Trail
171	Pueblo Canyon Trail
172	Pueblo Canyon Trail
173	Pueblo Canyon Trail
174	Pueblo Canyon Trail
175	Elevated Receptors at TA-43
176	Elevated Receptors at TA-43

*Set of Sensitive Receptors for Nonradiological
Air Quality Analysis-Continued*

RECEPTOR ID	RECEPTOR NAME
177	Elevated Receptors at TA-43
178	Elevated Receptors at TA-43
179	Elevated Receptors at TA-43
180	Elevated Receptors at TA-43

ATTACHMENT 4

DISPERSION MODELING METHODOLOGY USED TO DEVELOP SCREENING LEVEL EMISSION VALUES

Dispersion Modeling Analysis

The EPA's Industrial Source Complex Air Quality Dispersion Model (ISC-3) was used for the dispersion analyses conducted for this study. The ISC-3 model, which applies a steady-state Gaussian plume equation for a continuous source, is a validated model that is often used to estimate air quality impacts from existing and proposed sources of air pollutants. The ISC-3's short-term algorithm was used to estimate 8-hour and annual concentrations at each of the receptor locations. Flat terrain was assumed. An emission rate of 1 gram per second was used to establish the relationship between emission rate and concentration at the maximum receptor location for each TA.

The regulatory default options that were used include:

- Rural dispersion algorithm
- Final plume rise
- Stack-tip downwash
- Building downwash
- Buoyancy-induced dispersion
- Default wind speed and vertical temperature profiles
- Terrain receptors, equal to and below the height of the lowest stack

The land use within or near Los Alamos (using the EPA-recommended Auer's technique [Auer 1978]) was considered to be rural. As such, the Pasquill-Gifford rural dispersion coefficients were used for all dispersion analyses.

Five years of Los Alamos meteorological on-site observations for years 1991 through 1995 were used in dispersion analysis for nonradiological air emissions. These 5 years of data were obtained by using the EPA PC RAMMET program, with surface observations and morning and afternoon mixing heights data as inputs. The surface observations were collected at the TA-6 meteorological tower at LANL. Mixing heights were estimated based on the Albuquerque upper air observations and Santa Fe surface data.

Because the TA stacks and nearby buildings may be subject to building downwash (i.e., stack heights may be less than good-engineering practice [GEP] stack heights), the controlling prototypical building dimensions were entered as input into the dispersion analysis. Trinity Consultants' Breeze Air™ (TCI 1996) BPIP (Building Profile Input Program [EPA 1993a]) computer software were used to determine direction-specific building dimensions (height, projected width, and GEP stack height).

Because there are no other significant sources of toxic air pollutants near LANL facilities, background air toxin levels were assumed to be zero.

The ISC-3-estimated maximum 8-hour and annual pollutant concentrations associated with LANL TAs, for a test case of 1 gram per second, using 1991 through 1995 meteorological data, are provided in Table A of this attachment.

TABLE A.—The ISC-3 Estimated 8-Hour and Annual Concentrations Associated with LANL Technical Areas Using 1991–1995 Meteorological Data

8-HOUR ESTIMATED CONCENTRATIONS ($\mu\text{g}/\text{m}^3$) ^a					
METEOROLOGICAL DATA ^c					
TA	1991	1992	1993	1994	1995
00	279.49560	229.43240	276.49660	248.43500	287.41440
2	513.64450	473.75730	568.91710	509.66990	560.53440
3	163.81105	198.62587	155.75540	164.33449	155.43233
5	149.90700	162.09580	128.37780	138.83980	183.12160
8	324.95227	305.07642	251.05130	273.90700	321.50980
9	310.63486	244.58514	245.01843	262.47159	260.73364
11	353.89670	481.48288	365.60450	346.11150	285.51890
15	290.83716	292.22995	225.39305	219.32697	200.88281
16	123.92935	179.15591	150.07620	113.51302	122.97661
18	910.98451	665.79895	842.05798	787.37677	946.91431
21	432.78125	312.27692	427.35263	372.58060	403.49457
22	488.72080	524.60850	435.44110	446.54640	523.14040
33	177.21200	112.63840	120.58750	139.54990	118.77170
35	576.44983	557.09857	612.55536	610.81940	592.49658
36	282.37897	204.94788	295.61194	219.22858	389.92822
39	233.96115	285.91559	159.50490	249.67120	276.70010
40	322.70642	296.88312	323.19415	479.85321	367.77228
41	490.36520	657.47140	676.38990	709.29850	666.62910
46	318.06880	460.12480	297.29060	341.28820	299.20180
48	488.90000	534.90000	568.60000	589.30000	556.10000
50	456.40000	453.60000	484.60000	593.56396	478.00000
51	359.90330	430.70670	562.89490	421.93490	494.20170
53	190.86334	150.54651	147.59128	220.65263	209.51642
54	147.87006	207.02702	169.36514	219.19812	141.96089
55	860.71283	739.73020	968.98750	821.74750	1017.25200
59	684.99225	769.20410	730.56140	653.36480	769.62010
60	223.43800	250.81170	176.93660	274.93510	179.31870
61	234.10380	177.12100	218.73490	196.43460	253.92700
64	615.90990	784.60700	499.29060	462.26250	613.96380

TABLE A.—The ISC-3 Estimated 8-Hour and Annual Concentrations Associated with LANL Technical Areas Using 1991–1995 Meteorological Data-Continued

ANNUAL ESTIMATED CONCENTRATIONS ($\mu\text{g}/\text{m}^3$) ^b					
METEOROLOGICAL DATA ^c					
TA	1991	1992	1993	1994	1995
00	2.19354	1.76703	2.02104	1.69840	1.95963
2	4.48941	4.29066	4.98455	4.54396	4.59531
3	2.15460	1.96920	2.45068	2.46536	2.30553
5	0.74664	0.76824	0.73882	0.72562	0.67348
8	1.37394	1.26414	1.25554	1.22274	1.40186
9	0.60227	0.60095	0.71872	0.61262	0.56950
11	0.86231	0.81774	0.52535	0.45393	0.53742
15	0.29479	0.31361	0.28034	0.28057	0.26807
16	0.60160	0.78717	0.48017	0.61480	0.43183
18	0.46945	0.46511	0.43969	0.50015	0.45972
21	3.49665	2.61230	3.90596	3.67452	3.96519
22	0.51278	0.54939	0.58868	0.55958	0.52204
33	1.07322	0.99352	0.97370	1.06143	1.11189
35	0.55983	0.54803	0.65824	0.64655	0.60591
36	0.37314	0.39786	0.35679	0.34646	0.37540
39	2.55763	2.26826	3.05966	2.88462	2.97997
40	0.56740	0.54473	0.54502	0.60511	0.52467
41	5.10670	4.54171	5.34982	5.40181	5.26285
46	0.66202	0.54784	0.55816	0.52594	0.57425
48	2.69000	2.25000	2.88000	2.94752	2.82000
50	0.56421	0.59867	0.64865	0.57143	0.57586
51	0.52689	0.57286	0.62493	0.71755	0.66236
53	2.13802	2.31454	2.42821	2.31592	2.25865
54	0.68160	0.61071	0.69577	0.78755	0.68274
55	0.58653	0.65019	0.67169	0.63840	0.57909
59	1.61045	1.49807	1.86697	1.76562	1.87894
60	3.53892	3.61417	3.45185	3.48662	3.48484
61	3.79212	4.02321	4.07485	4.00865	3.79064
64	1.51835	1.34770	1.40558	1.43161	1.54660

Notes:

^a 8-hour pollutant concentrations were estimated at the fence line receptors located around each TA.

^b Annual pollutant concentrations were estimated at the sensitive receptors.

^c Bold entries indicate that the highest concentration occurs for this year of the meteorological event.

**ATTACHMENT 5
EIGHT-HOUR SCREENING LEVEL EMISSION VALUES
(TABLE 1) AND ANNUAL SCREENING LEVEL EMISSION
VALUES FOR CHEMICALS (TABLE 2) TA-3 EXAMPLE
WORKSHEETS**

TABLE 1 (PART A).—8-Hour SLEVs of the Toxic (Noncarcinogenic and Carcinogenic) Air Pollutants from TA-3 Facilities Based on RAPS-90 (LANL 1990) and ACIS 1995 (LANL 1995a) Data

NO.	TOXIC AIR POLLUTANTS	CAS NUMBER	OELS $\mu\text{g}/\text{m}^3$	1/100 OF THE OELS $\mu\text{g}/\text{m}^3$	8-HOUR SLEVs		RAPS 1990 DATA		ACIS 1995 DATA			THE SMALLER (R ¹) OR (R ²) RATIO
					g/sec	lb/hr	HOURLY EMISSION RATE FROM RAPS (Q ^{hr})	RATIO SLEVs/Q ^{hr} (R ¹)	PURCHASED AMOUNT OF CHEMICALS FROM ACIS	ESTIMATED HOURLY EMISSION RATES (Q ^{hr})	RATIO SLEVs/Q ^{hr} (R ²)	
1	2	3	4	5	6	7	8	9	10	11	12	13
NONCARCINOGENIC POLLUTANTS												
1	1,1 Dichloroethane	75-34-3	400,000	4,000	2.01E+01	1.60E+02						
2	1,1,2-Trichloro-1,2,2-Trifluoroethane	76-13-1	7,600,000	76,000	3.83E+02	3.04E+03						
3	1,1-Dichloro-Nitroethane	594-72-9	10,000	100	5.03E-01	4.00E+00						
4	1,4-Dioxane	123-91-1	90,000	900	4.53E+00	3.60E+01	8.44E-04	4.26E+04	9.08E+00	7.95E-03	4.52E+03	4.52E+03
5	1,1,1-Trichloroethane	71-55-6	1,900,000	19,000	9.57E+01	7.59E+02			1.51E+03	1.32E+00	5.74E+02	5.74E+02
6	1,2,4-Trimethylbenzene	95-63-6	123,000	1,230	6.19E+00	4.91E+01						
7	1,2-Dichloroethylene	540-59-0	790,000	7,900	3.98E+01	3.16E+02						
8	1,3,5-Trimethylbenzene	108-67-8	123,000	1,230	6.19E+00	4.91E+01						
9	1-Chloro-1-Nitropropane	600-25-9	10,000	100	5.03E-01	4.00E+00						
10	1-Nitropropane	108-03-2	90,000	900	4.53E+00	3.60E+01						
11	2,4,6-Trinitrotoluene	118-96-7	500	5	2.52E-02	2.00E-01						
12	2-Aminopyridine	504-29-0	2,000	20	1.01E-01	7.99E-01						
13	2-Butoxyethanol	111-76-2	121,000	1,210	6.09E+00	4.83E+01	5.11E-01	9.47E+01				9.47E+01
14	2-Butoxyethanol Acetate	112-07-2	33,000	330	1.66E+00	1.32E+01						
15	2-Diethylaminoethanol	100-37-8	9,600	96	4.83E-01	3.84E+00						
16	2-Ethoxyethanol	110-80-5	18,000	180	9.06E-01	7.19E+00						
17	2-Ethoxyethyl Acetate	111-15-9	27,000	270	1.36E+00	1.08E+01						
18	2-Hydroxypropyl Acrylate	999-61-1	2,800	28	1.41E-01	1.12E+00						

TABLE 1 (PART A).—8-Hour SLEVs of the Toxic (Noncarcinogenic and Carcinogenic) Air Pollutants from TA-3 Facilities Based on RAPS-90 (LANL 1990) and ACIS 1995 (LANL 1995a) Data-Continued

NO.	TOXIC AIR POLLUTANTS	CAS NUMBER	OELS $\mu\text{g}/\text{m}^3$	1/100 OF THE OELS $\mu\text{g}/\text{m}^3$	8-HOUR SLEVS		RAPS 1990 DATA		ACIS 1995 DATA			THE SMALLER (R^1) OR (R^2) RATIO
					g/sec	lb/hr	HOURLY EMISSION RATE FROM RAPS (Q^{hr}) lb/hr	RATIO SLEVS/ Q^{hr} (R^1)	PURCHASED AMOUNT OF CHEMICALS FROM ACIS lb/year	ESTIMATED HOURLY EMISSION RATES (Q^{hr}) lb/hr	RATIO SLEVS/ Q^{hr} (R^2)	
1	2	3	4	5	6	7	8	9	10	11	12	13
19	2-Methoxyethanol	109-86-4	16,000	160	8.06E-01	6.39E+00						
20	2-Methoxyethyl Acetate	110-49-6	24,000	240	1.21E+00	9.59E+00						
21	2-Methyl Cyclopentadienyl Manganese Tricarbonyl	12108-13-3	200	2	1.01E-02	7.99E-02						
22	4-Methoxyphenol	150-76-5	5,000	50	2.52E-01	2.00E+00						
23	a-Methyl Styrene	98-83-9	242,000	2,420	1.22E+01	9.67E+01						
24	Acetic Acid	64-19-7	25,000	250	1.26E+00	9.99E+00	2.84E+00	3.51E+00	1.62E+01	1.42E-02	7.04E+02	3.51E+00
25	Acetic Anhydride	108-24-7	20,000	200	1.01E+00	7.99E+00	--					
26	Acetone	67-64-1	1,780,000	17,800	8.96E+01	7.11E+02	2.41E+00	2.95E+02	5.64E+02	4.93E-01	1.44E+03	2.95E+02
27	Acetonitrile	75-05-8	67,000	670	3.37E+00	2.68E+01	--		2.41E+01	2.11E-02	1.27E+03	1.27E+03
28	Acetophenone	98-86-2	49,000	490	2.47E+00	1.96E+01	--					
29	Acetylene	74-86-2	2,662,000	26,620	1.34E+02	1.06E+03			9.09E+02	7.95E-01	1.34E+03	1.34E+03
30	Acetylene Tetrabromide	79-27-6	14,000	140	7.05E-01	5.59E+00	--					
31	Acrolein	107-02-8	230	2	1.16E-02	9.19E-02						
32	Acrylic Acid	79-10-7	5,900	59	2.97E-01	2.36E+00			6.95E-01	6.08E-04	3.88E+03	1.34E+03
33	Adiponitrile	111-69-3	8,800	88	4.43E-01	3.52E+00						
34	Allyl Alcohol	107-18-6	4,800	48	2.42E-01	1.92E+00	--					
35	Allyl Glycidyl Ether	106-92-3	23,000	230	1.16E+00	9.19E+00						
36	Aluminum, Metal Dust, as Al	7429-90-5	10,000	100	5.03E-01	4.00E+00	4.09E-02	9.78E+01	2.20E+00	1.93E-03	2.08E+03	9.78E+01
37	Aluminum Alkyls not otherwise classified	7429-90-5	2,000	20	1.01E-01	7.99E-01						

TABLE 1 (PART A).—8-Hour SLEVs of the Toxic (Noncarcinogenic and Carcinogenic) Air Pollutants from TA-3 Facilities Based on RAPS-90 (LANL 1990) and ACIS 1995 (LANL 1995a) Data-Continued

NO.	TOXIC AIR POLLUTANTS	CAS NUMBER	OELS $\mu\text{g}/\text{m}^3$	1/100 OF THE OELS $\mu\text{g}/\text{m}^3$	8-HOUR SLEVS		RAPS 1990 DATA		ACIS 1995 DATA			THE SMALLER (R ¹) OR (R ²) RATIO
					g/sec	lb/hr	HOURLY EMISSION RATE FROM RAPS (Q ^{hr})	RATIO SLEVS/Q ^{hr} (R ¹)	PURCHASED AMOUNT OF CHEMICALS FROM ACIS	ESTIMATED HOURLY EMISSION RATES (Q ^{hr})	RATIO SLEVS/Q ^{hr} (R ²)	
1	2	3	4	5	6	7	8	9	10	11	12	13
38	Aluminum Pyro Powders, as Al	7429-90-5	5,000	50	2.52E-01	2.00E+00						
39	Aluminum, Welding Fumes, as Al	7429-90-5	5,000	50	2.52E-01	2.00E+00	6.04E-01	3.31E+00				3.31E+00
40	Amitrole	61-8-5	200	2	1.01E-02	7.99E-02						
41	Ammonia	7664-41-7	17,000	170	8.56E-01	6.79E+00	7.09E-01	9.59E+00				9.59E+00
42	Ammonia Chloride (Fume)	12125-02-9	10,000	100	5.03E-01	4.00E+00						
43	Aniline & Homologues	62-53-3	7,600	76	3.83E-01	3.04E+00	2.81E-04	1.08E+04				1.08E+04
44	Anisidine (o-, p-isomers)	29191-52-4	500	5	2.52E-02	2.00E-01						
45	Antimony and Compounds, as Sb	7440-36-0	500	5	2.52E-02	2.00E-01			2.47E-01	2.16E-04	9.25E+02	9.25E+02
46	Arsine	7784-42-1	160	2	8.06E-03	6.39E-02						
47	Asphalt (Petroleum) Fumes	8052-42-4	5,000	50	2.52E-01	2.00E+00						
48	Benzenethiol	108-98-5	500	5	2.52E-02	2.00E-01						
49	Benzoyl Peroxide	94-36-0	5,000	50	2.52E-01	2.00E+00						
50	Biphenyl	92-52-4	1,000	10	5.03E-02	4.00E-01						
51	Bismuth Telluride	1304-82-1	5,000	50	2.52E-01	2.00E+00						
52	Boron Oxide	1303-86-2	10,000	100	5.03E-01	4.00E+00	7.25E-04	5.51E+03				5.51E+03
53	Boron Trifluoride	7637-07-2	3,000	30	1.51E-01	1.20E+00	3.50E-04	3.42E+03				3.42E+03
54	Bromine	7726-95-6	660	7	3.32E-02	2.64E-01	5.00E-04	5.27E+02				5.27E+02
55	Bromine Pentafluoride	7789-30-2	700	7	3.52E-02	2.80E-01						
56	Bromoform	75-25-2	5,000	50	2.52E-01	2.00E+00						

TABLE 1 (PART A).—8-Hour SLEVs of the Toxic (Noncarcinogenic and Carcinogenic) Air Pollutants from TA-3 Facilities Based on RAPS-90 (LANL 1990) and ACIS 1995 (LANL 1995a) Data-Continued

NO.	TOXIC AIR POLLUTANTS	CAS NUMBER	OELS $\mu\text{g}/\text{m}^3$	1/100 OF THE OELS $\mu\text{g}/\text{m}^3$	8-HOUR SLEVs		RAPS 1990 DATA		ACIS 1995 DATA			THE SMALLER (R^1) OR (R^2) RATIO
					g/sec	lb/hr	HOURLY EMISSION RATE FROM RAPS (Q^{hr})	RATIO SLEVs/ Q^{hr} (R^1)	PURCHASED AMOUNT OF CHEMICALS FROM ACIS	ESTIMATED HOURLY EMISSION RATES (Q^{hr})	RATIO SLEVs/ Q^{hr} (R^2)	
1	2	3	4	5	6	7	8	9	10	11	12	13
57	Butyl Mercaptan	109-79-5	1,500	15	7.55E-02	5.99E-01						
58	Carbon Black	1333-86-4	3,500	35	1.76E-01	1.40E+00	1.47E-02	9.49E+01	1.10E+00	9.63E-04	1.45E+03	9.49E+01
59	Carbon Disulfide	75-15-0	31,000	310	1.56E+00	1.24E+01						
60	Carbon Tetrabromide	558-13-4	1,400	14	7.05E-02	5.59E-01						
61	Catechol	120-80-9	23,000	230	1.16E+00	9.19E+00						
62	Cesium Hydroxide	21351-79-1	2,000	20	1.01E-01	7.99E-01						
63	Chlorinated Camphene	8001-35-2	500	5	2.52E-02	2.00E-01						
64	Chlorine	7782-50-5	1,500	15	7.55E-02	5.99E-01	1.40E-04	4.28E+03				4.28E+03
65	Chlorine Trifluoride	7790-91-2	400	4	2.01E-02	1.60E-01						
66	Chloroacetaldehyde	107-20-0	3,000	30	1.51E-01	1.20E+00						
67	Chloroacetyl Chloride	79-04-9	200	2	1.01E-02	7.99E-02						
68	Chlorobenzene	108-90-7	46,000	460	2.32E+00	1.84E+01	1.88E-03	9.80E+03				9.80E+03
69	Chlorodifluoromethane	75-45-6	3,540,000	35,400	1.78E+02	1.41E+03						
70	Chromium, Metal & Cr III Compounds, as Cr	7440-47-3	500	5	2.52E-02	2.00E-01	4.46E-04	4.48E+02	1.10E+00	9.63E-04	2.08E+02	2.08E+02
71	Cobalt Carbonyl, as Co	10210-68-1	100	1	5.03E-03	4.00E-02						
72	Cobalt Hydroxycarbonyl, as Co	16842-03-8	100	1	5.03E-03	4.00E-02						
73	Cobalt, elemental & inorg. comp., as Co	7440-48-4	20	0	1.01E-03	7.99E-03	2.80E-06	2.85E+03				2.85E+03
74	Copper, Dusts & Mists, as Cu	7440-50-8	1,000	10	5.03E-02	4.00E-01	7.07E-04	5.66E+02	1.30E+00	1.14E-03	3.51E+02	3.51E+02
75	Copper, Fume, as Cu	7440-50-8	200	2	1.01E-02	7.99E-02	5.48E-04	1.46E+02				1.46E+02
76	Cresol (all isomers)	1319-77-3	22,000	220	1.11E+00	8.79E+00						

TABLE 1 (PART A).—8-Hour SLEVs of the Toxic (Noncarcinogenic and Carcinogenic) Air Pollutants from TA-3 Facilities Based on RAPS-90 (LANL 1990) and ACIS 1995 (LANL 1995a) Data-Continued

NO.	TOXIC AIR POLLUTANTS	CAS NUMBER	OELS $\mu\text{g}/\text{m}^3$	1/100 OF THE OELS $\mu\text{g}/\text{m}^3$	8-HOUR SLEVS		RAPS 1990 DATA		ACIS 1995 DATA			THE SMALLER (R^1) OR (R^2) RATIO
					g/sec	lb/hr	HOURLY EMISSION RATE FROM RAPS (Q^{hr})	RATIO SLEVS/ Q^{hr} (R^1)	PURCHASED AMOUNT OF CHEMICALS FROM ACIS	ESTIMATED HOURLY EMISSION RATES (Q^{hr})	RATIO SLEVS/ Q^{hr} (R^2)	
1	2	3	4	5	6	7	8	9	10	11	12	13
77	Crotonaldehyde	4170-30-3	5,700	57	2.87E-01	2.28E+00						
78	Cumene	98-28-8	245,000	2,450	1.23E+01	9.79E+01						
79	Cyanamide	420-04-2	2,000	20	1.01E-01	7.99E-01						
80	Cyanogen	460-19-5	20,000	200	1.01E+00	7.99E+00						
81	Cyanogen Chloride	506-77-4	750	8	3.78E-02	3.00E-01						
82	Cyclohexane	110-82-7	1,030,000	10,300	5.19E+01	4.12E+02	4.53E-02	9.10E+03				9.10E+03
83	Cyclohexanol	108-93-0	200,000	2,000	1.01E+01	7.99E+01						
84	Cyclohexanone	108-94-1	100,000	1,000	5.03E+00	4.00E+01						
85	Cyclohexene	110-83-8	1,010,000	10,100	5.08E+01	4.04E+02						
86	Cyclohexylamine	108-91-8	40,000	400	2.01E+00	1.60E+01						
87	Cyclopentadiene	542-92-7	200,000	2,000	1.01E+01	7.99E+01						
88	Cyclopentane	287-92-3	1,720,000	17,200	8.66E+01	6.87E+02						
89	Decaborane	17702-41-9	250	3	1.26E-02	9.99E-02						
90	Di-sec, Octyl Phthalate	117-81-7	5,000	50	2.52E-01	2.00E+00						
91	Diacetone Alcohol	123-42-2	238,000	2,380	1.20E+01	9.51E+01						
92	Diazinon	333-41-5	100	1	5.03E-03	4.00E-02						
93	Diazomethane	334-88-3	340	3	1.71E-02	1.36E-01						
94	Dibutyl Phosphate	107-66-4	5,000	50	2.52E-01	2.00E+00						
95	Dibutyl Phthalate	84-74-2	5,000	50	2.52E-01	2.00E+00						
96	Dichlorodifluoromethane	75-71-8	4,950,000	49,500	2.49E+02	1.98E+03	7.95E-03	2.49E+05				2.49E+05
97	Dichlorofluoromethane	75-43-4	42,000	420	2.11E+00	1.68E+01						
98	Dichlorovos	62-73-7	900	9	4.53E-02	3.60E-01						
99	Dicyclopentadiene	77-73-6	27,000	270	1.36E+00	1.08E+01						

TABLE 1 (PART A).—8-Hour SLEVs of the Toxic (Noncarcinogenic and Carcinogenic) Air Pollutants from TA-3 Facilities Based on RAPS-90 (LANL 1990) and ACIS 1995 (LANL 1995a) Data-Continued

NO.	TOXIC AIR POLLUTANTS	CAS NUMBER	OELS $\mu\text{g}/\text{m}^3$	1/100 OF THE OELS $\mu\text{g}/\text{m}^3$	8-HOUR SLEVS		RAPS 1990 DATA		ACIS 1995 DATA			THE SMALLER (R^1) OR (R^2) RATIO
					g/sec	lb/hr	HOURLY EMISSION RATE FROM RAPS (Q^{hr})	RATIO SLEVS/ Q^{hr} (R^1)	PURCHASED AMOUNT OF CHEMICALS FROM ACIS	ESTIMATED HOURLY EMISSION RATES (Q^{hr})	RATIO SLEVS/ Q^{hr} (R^2)	
1	2	3	4	5	6	7	8	9	10	11	12	13
100	Dicyclopentadienyl Iron	102-54-5	10,000	100	5.03E-01	4.00E+00						
101	Diethyl Ketone	96-22-0	705,000	7,050	3.55E+01	2.82E+02	1.00E-03	2.82E+05				2.82E+05
102	Diethyl Phthalate	84-66-2	5,000	50	2.52E-01	2.00E+00						
103	Diethylamine	109-89-7	15,000	150	7.55E-01	5.99E+00	1.00E-04	5.99E+04				5.99E+04
104	Diethylene Triamine	111-40-0	1,000	10	5.03E-02	4.00E-01			6.05E+00	5.30E-03	7.55E+01	7.55E+01
105	Diisopropylamine	108-18-9	21,000	210	1.06E+00	8.39E+00						
106	Dimethoxymethane	109-87-5	3,100,000	31,000	1.56E+02	1.24E+03						
107	Dimethyl Acetamide	127-19-5	35,000	350	1.76E+00	1.40E+01						
108	Dimethyl Amine	124-40-3	9,200	92	4.63E-01	3.68E+00						
109	Dimethyl Phthalate	131-11-3	5,000	50	2.52E-01	2.00E+00						
110	Dimethyl Sulfate	77-78-1	520	5	2.62E-02	2.08E-01						
111	Dinitro-o-Cresol	534-52-1	200	2	1.01E-02	7.99E-02						
112	Dinitrobenzene (all isomers)	99-65-0	1,000	10	5.03E-02	4.00E-01						
113	Dinitrotoluene	25321-14-6	150	2	7.55E-03	5.99E-02						
114	Diphenylamine	122-39-4	10,000	100	5.03E-01	4.00E+00						
115	Dipropyl Ketone	123-19-3	233,000	2,330	1.17E+01	9.31E+01						
116	Dipropylene Glycol Methyl Ether	34590-94-8	600,000	6,000	3.02E+01	2.40E+02						
117	Divinyl Benzene	1321-74-0	50,000	500	2.52E+00	2.00E+01						
118	Endrin	72-20-8	100	1	5.03E-03	4.00E-02						
119	Enflurane	13838-16-9	566,000	5,660	2.85E+01	2.26E+02						
120	Ethanol	64-17-5	1,880,000	18,800	9.47E+01	7.51E+02			6.52E+02	5.70E-01	1.32E+03	1.32E+03
121	Ethanolamine	141-43-5	6,000	60	3.02E-01	2.40E+00			2.25E+00	1.97E-03	1.22E+03	1.22E+03

TABLE 1 (PART A).—8-Hour SLEVs of the Toxic (Noncarcinogenic and Carcinogenic) Air Pollutants from TA-3 Facilities Based on RAPS-90 (LANL 1990) and ACIS 1995 (LANL 1995a) Data-Continued

NO.	TOXIC AIR POLLUTANTS	CAS NUMBER	OELS $\mu\text{g}/\text{m}^3$	1/100 OF THE OELS $\mu\text{g}/\text{m}^3$	8-HOUR SLEVS		RAPS 1990 DATA		ACIS 1995 DATA			THE SMALLER (R ¹) OR (R ²) RATIO
					g/sec	lb/hr	HOURLY EMISSION RATE FROM RAPS (Q ^{hr})	RATIO SLEVS/Q ^{hr} (R ¹)	PURCHASED AMOUNT OF CHEMICALS FROM ACIS	ESTIMATED HOURLY EMISSION RATES (Q ^{hr})	RATIO SLEVS/Q ^{hr} (R ²)	
1	2	3	4	5	6	7	8	9	10	11	12	13
122	Ethion	563-12-2	400	4	2.01E-02	1.60E-01						
123	Ethyl Acetate	141-78-6	1,400,000	14,000	7.05E+01	5.59E+02	2.78E-03	2.02E+05	5.06E+01	4.43E-02	1.26E+04	1.26E+04
124	Ethyl Benzene	100-41-04	434,000	4,340	2.19E+01	1.73E+02						
125	Ethyl Bromide	74-96-4	22,000	220	1.11E+00	8.79E+00						
126	Ethyl Chloride	75-00-3	264,000	2,640	1.33E+01	1.05E+02	1.50E-04	7.03E+05				7.03E+05
127	Ethyl Ether	60-29-7	1,200,000	12,000	6.04E+01	4.79E+02	7.50E-03	6.39E+04	6.26E+00	5.48E-03	8.75E+04	6.39E+04
128	Ethyl Formate	109-94-4	300,000	3,000	1.51E+01	1.20E+02						
129	Ethyl Mercaptan	75-08-1	1,300	13	6.54E-02	5.19E-01						
130	Ethylamine	75-04-7	9,200	92	4.63E-01	3.68E+00						
131	Ethylene Chlorohydrin	107-07-3	3,000	30	1.51E-01	1.20E+00						
132	Ethylene Diamine	107-15-3	25,000	250	1.26E+00	9.99E+00						
133	Fibrous Glass Dust	NA	10,000	100	5.03E-01	4.00E+00						
134	Fluorides, as F	NA	2,500	25	1.26E-01	9.99E-01	1.33E-02	7.49E+01				7.49E+01
135	Fluorine	7782-41-4	200	2	1.01E-02	7.99E-02						
136	Formamide	75-12-7	18,000	180	9.06E-01	7.19E+00	2.38E-02	3.03E+02				3.03E+02
137	Formic Acid	64-18-6	9,000	90	4.53E-01	3.60E+00	2.56E-04	1.41E+04	1.35E+00	1.18E-03	3.06E+03	3.06E+03
138	Furfural	98-01-1	800	8	4.03E-02	3.20E-01						
139	Furfuryl Alcohol	98-00-0	40,000	400	2.01E+00	1.60E+01			4.95E+01	4.33E-02	3.69E+02	3.69E+02
140	Gasoline	8006-61-9	890,000	8,900	4.48E+01	3.56E+02						
141	Germanium Tetrahydride	7782-65-2	600	6	3.02E-02	2.40E-01	1.10E-07	2.18E+06				2.18E+06
142	Glutaraldehyde	111-30-8	700	7	3.52E-02	2.80E-01	5.00E-07	5.59E+05	7.28E-01	6.37E-04	4.39E+02	4.39E+02
143	Hafnium	7440-58-6	500	5	2.52E-02	2.00E-01	1.25E-05	1.60E+04	1.33E+00	1.16E-03	1.72E+02	1.72E+02
144	Hexafluoroacetone	684-16-2	680	7	3.42E-02	2.72E-01						

TABLE 1 (PART A).—8-Hour SLEVs of the Toxic (Noncarcinogenic and Carcinogenic) Air Pollutants from TA-3 Facilities Based on RAPS-90 (LANL 1990) and ACIS 1995 (LANL 1995a) Data-Continued

NO.	TOXIC AIR POLLUTANTS	CAS NUMBER	OELS $\mu\text{g}/\text{m}^3$	1/100 OF THE OELS $\mu\text{g}/\text{m}^3$	8-HOUR SLEVS		RAPS 1990 DATA		ACIS 1995 DATA			THE SMALLER (R^1) OR (R^2) RATIO
					g/sec	lb/hr	HOURLY EMISSION RATE FROM RAPS (Q^{hr})	RATIO SLEVS/ Q^{hr} (R^1)	PURCHASED AMOUNT OF CHEMICALS FROM ACIS	ESTIMATED HOURLY EMISSION RATES (Q^{hr})	RATIO SLEVS/ Q^{hr} (R^2)	
1	2	3	4	5	6	7	8	9	10	11	12	13
145	Hexamethylene Dithiocyanate	822-06-0	34	0.3	1.71E-03	1.36E-02						
146	Hexane (other isomers)*	110-54-3	1,760,000	17,600	8.86E+01	7.03E+02	2.63E-02	2.68E+04				2.68E+04
147	Hexylene Glycol	107-41-5	121,000	1,210	6.09E+00	4.83E+01						
148	Hydrogen Bromide	10035-10-6	9,900	99	4.98E-01	3.96E+00	8.70E-03	4.55E+02	1.97E+01	1.72E-02	2.29E+02	2.29E+02
149	Hydrogen Chloride	7647-01-0	7,000	70	3.52E-01	2.80E+00	5.36E-01	5.22E+00	5.27E+02	4.61E-01	6.07E+00	5.22E+00
150	Hydrogen Cyanide	74-90-8	5,000	50	2.52E-01	2.00E+00						
151	Hydrogen Fluoride, as F	7664-39-3	2,300	23	1.16E-01	9.19E-01	1.20E-02	7.67E+01	2.74E+01	2.39E-02	3.84E+01	3.84E+01
152	Hydrogen Peroxide	7722-84-1	1,400	14	7.05E-02	5.59E-01	1.28E-02	4.37E+01	7.47E+01	6.53E-02	8.56E+00	8.56E+00
153	Hydrogen Sulfide	7783-06-4	1,400	14	7.05E-02	5.59E-01	1.00E-07	5.59E+06				5.59E+06
154	Hydroquinone	123-31-9	2,000	20	1.01E-01	7.99E-01	1.07E-05	7.50E+04				7.50E+04
155	Indene	95-13-6	45,000	450	2.27E+00	1.80E+01						
156	Indium & compounds, as In	7440-74-6	100	1	5.03E-03	4.00E-02			6.00E-01	5.25E-04	7.61E+01	7.61E+01
157	Iodine	7553-56-2	1,000	10	5.03E-02	4.00E-01			3.00E-01	2.63E-04	1.52E+03	1.52E+03
158	Iodoform	75-47-8	10,000	100	5.03E-01	4.00E+00						
159	Iron Oxide Fume, as Fe	1309-37-1	5,000	50	2.52E-01	2.00E+00						
160	Iron Pentacarbonyl, as Fe	13463-4--6	800	8	4.03E-02	3.20E-01						
161	Iso-Amyl Acetate	123-92-2	525,000	5,250	2.64E+01	2.10E+02						
162	Iso-Amyl Alcohol	123-51-3	360,000	3,600	1.81E+01	1.44E+02	6.25E-04	2.30E+05				2.30E+05
163	Isobutane	75-28-5	1,936,000	19,360	9.75E+01	7.74E+02						
164	Isobutyl Acetate	110-19-0	700,000	7,000	3.52E+01	2.80E+02	2.28E-03	1.23E+05				1.23E+05
165	Isobutyl Alcohol	78-83-1	150,000	1,500	7.55E+00	5.99E+01	1.29E-03	4.66E+04				4.66E+04
166	Isobutyronitrile	78-82-0	22,000	220	1.11E+00	8.79E+00						

TABLE 1 (PART A).—8-Hour SLEVs of the Toxic (Noncarcinogenic and Carcinogenic) Air Pollutants from TA-3 Facilities Based on RAPS-90 (LANL 1990) and ACIS 1995 (LANL 1995a) Data-Continued

NO.	TOXIC AIR POLLUTANTS	CAS NUMBER	OELS $\mu\text{g}/\text{m}^3$	1/100 OF THE OELS $\mu\text{g}/\text{m}^3$	8-HOUR SLEVS		RAPS 1990 DATA		ACIS 1995 DATA			THE SMALLER (R ¹) OR (R ²) RATIO
					g/sec	lb/hr	HOURLY EMISSION RATE FROM RAPS (Q ^{hr})	RATIO SLEVS/Q ^{hr} (R ¹)	PURCHASED AMOUNT OF CHEMICALS FROM ACIS	ESTIMATED HOURLY EMISSION RATES (Q ^{hr})	RATIO SLEVS/Q ^{hr} (R ²)	
1	2	3	4	5	6	7	8	9	10	11	12	13
167	Isocetyl Alcohol	26952-21-6	266,000	2,660	1.34E+01	1.06E+02	1.25E-04	8.50E+05				8.50E+05
168	Isophorone	78-59-1	23,000	230	1.16E+00	9.19E+00						
169	Isophorone Diisocyanate	4098-71-9	45	0	2.27E-03	1.80E-02						
170	Isopropoxyethanol	109-59-1	106,000	1,060	5.34E+00	4.24E+01						
171	Isopropyl Acetate	108-21-4	950,000	9,500	4.78E+01	3.80E+02						
172	Isopropyl Alcohol	67-63-0	980,000	9,800	4.93E+01	3.92E+02	1.93E+00	2.03E+02	6.22E+02	5.44E-01	7.20E+02	2.03E+02
173	Isopropyl Ether	108-20-3	1,040,000	10,400	5.24E+01	4.16E+02	2.50E-04	1.66E+06				1.66E+06
174	Isopropylamine	75-31-0	12,000	120	6.04E-01	4.79E+00						
175	Kerosene	8008-20-6	100,000	1,000	5.03E+00	4.00E+01	9.75E-01	4.10E+01	1.00E+02	8.75E-02	4.57E+02	4.10E+01
176	Lead, el. & inorg. compounds, as Pb	7439-92-1	50	0.5	2.52E-03	2.00E-02						
177	Lithium Hydride	7580-67-8	25	0.25	1.26E-03	9.99E-03	1.02E-02	9.82E-01				9.82E-01
178	m-Cresol	108-39-4	10,000	100	5.03E-01	4.00E+00						
179	m-Phenylenediamine	108-45-2	100	1	5.03E-03	4.00E-02						
180	m-Toluidine	108-44-1	8,800	88	4.43E-01	3.52E+00						
181	Magnesium Oxide Fume	1309-48-4	10,000	100	5.03E-01	4.00E+00	3.60E-02	1.11E+02				1.11E+02
182	Maleic Anhydride	108-31-6	1,000	10	5.03E-02	4.00E-01						
183	Malononitrile	109-77-3	8,000	80	4.03E-01	3.20E+00						
184	Manganese as Dust & Compounds, as Mn	7439-96-5	200	2	1.01E-02	7.99E-02	5.00E-05	1.60E+03				1.60E+03
185	Manganese as Mn Fume	7439-96-5	200	2	1.01E-02	7.99E-02	2.75E-06	2.91E+04				2.91E+04
186	Mercury (inorganic forms, incl. metallic Hg)	7439-97-6	25	0.25	1.26E-03	9.99E-03						

TABLE 1 (PART A).—8-Hour SLEVs of the Toxic (Noncarcinogenic and Carcinogenic) Air Pollutants from TA-3 Facilities Based on RAPS-90 (LANL 1990) and ACIS 1995 (LANL 1995a) Data-Continued

NO.	TOXIC AIR POLLUTANTS	CAS NUMBER	OELS $\mu\text{g}/\text{m}^3$	1/100 OF THE OELS $\mu\text{g}/\text{m}^3$	8-HOUR SLEVS		RAPS 1990 DATA		ACIS 1995 DATA			THE SMALLER (R^1) OR (R^2) RATIO
					g/sec	lb/hr	HOURLY EMISSION RATE FROM RAPS (Q^{hr})	RATIO SLEVS/ Q^{hr} (R^1)	PURCHASED AMOUNT OF CHEMICALS FROM ACIS	ESTIMATED HOURLY EMISSION RATES (Q^{hr})	RATIO SLEVS/ Q^{hr} (R^2)	
1	2	3	4	5	6	7	8	9	10	11	12	13
187	Mercury Alkyl Compounds	7439-97-6	10	0.1	5.03E-04	4.00E-03						
188	Mercury Aryl Compounds	7439-97-6	100	1	5.03E-03	4.00E-02						
189	Methacrylic Acid	79-41-4	70,000	700	3.52E+00	2.80E+01						
190	Methoxychlor	72-43-5	10,000	100	5.03E-01	4.00E+00						
191	Methyl 2-Cyanoacrylate	137-05-3	8,000	80	4.03E-01	3.20E+00	1.95E-03	1.64E+03				1.64E+03
192	Methyl Acetate	79-20-9	606,000	6,060	3.05E+01	2.42E+02						
193	Methyl Acetylene	74-99-7	1,640,000	16,400	8.26E+01	6.55E+02						
194	Methyl Acrylate	96-33-3	35,000	350	1.76E+00	1.40E+01						
195	Methyl Alcohol	67-56-1	260,000	2,600	1.31E+01	1.04E+02	6.60E-01	1.57E+02	5.80E+02	5.08E-01	2.05E+02	1.57E+02
196	Methyl Cyclohexane	108-87-2	1,610,000	16,100	8.11E+01	6.43E+02						
197	Methyl Ethyl Ketone	78-93-3	590,000	5,900	2.97E+01	2.36E+02	8.62E-01	2.73E+02	1.00E+01	8.78E-03	2.69E+04	2.73E+02
198	Methyl Formate	107-31-3	246,000	2,460	1.24E+01	9.83E+01						
199	Methyl Hydrazine	60-34-4	19	0	9.57E-04	7.59E-03						
200	Methyl Iodide	74-88-4	12,000	120	6.04E-01	4.79E+00						
201	Methyl Isobutyl Carbinol	108-11-2	100,000	1,000	5.03E+00	4.00E+01						
202	Methyl Isobutyl Ketone	108-10-1	205,000	2,050	1.03E+01	8.19E+01	1.71E-02	4.80E+03	1.76E+00	1.54E-03	5.31E+04	4.80E+03
203	Methyl Isocyanate	624-83-9	47	0.47	2.37E-03	1.88E-02						
204	Methyl Mercaptan	74-93-1	980	10	4.93E-02	3.92E-01						
205	Methyl Methacrylate	80-62-6	410,000	4,100	2.06E+01	1.64E+02	3.30E-06	4.96E+07				4.96E+07
206	Methyl n-Amyl Ketone	110-43-0	233,000	2,330	1.17E+01	9.31E+01						
207	Methyl n-Butyl Ketone	591-78-6	20,000	200	1.01E+00	7.99E+00	5.00E-03	1.60E+03				1.60E+03
208	Methyl Propyl Ketone	107-87-9	6,000	60	3.02E-01	2.40E+00	2.50E-04	9.59E+03				9.59E+03

TABLE 1 (PART A).—8-Hour SLEVs of the Toxic (Noncarcinogenic and Carcinogenic) Air Pollutants from TA-3 Facilities Based on RAPS-90 (LANL 1990) and ACIS 1995 (LANL 1995a) Data-Continued

NO.	TOXIC AIR POLLUTANTS	CAS NUMBER	OELS $\mu\text{g}/\text{m}^3$	1/100 OF THE OELS $\mu\text{g}/\text{m}^3$	8-HOUR SLEVS		RAPS 1990 DATA		ACIS 1995 DATA			THE SMALLER (R ¹) OR (R ²) RATIO
					g/sec	lb/hr	HOURLY EMISSION RATE FROM RAPS (Q ^{hr})	RATIO SLEVS/Q ^{hr} (R ¹)	PURCHASED AMOUNT OF CHEMICALS FROM ACIS	ESTIMATED HOURLY EMISSION RATES (Q ^{hr})	RATIO SLEVS/Q ^{hr} (R ²)	
1	2	3	4	5	6	7	8	9	10	11	12	13
209	Methyl Silicate	681-84-5	6,000	60	3.02E-01	2.40E+00						
210	Methylacrylonitrile	126-98-7	2,700	27	1.36E-01	1.08E+00						
211	Methylamine	74-89-5	6,400	64	3.22E-01	2.56E+00						
212	Methylene Bisphenyl Isocyanate	101-68-8	51	1	2.57E-03	2.04E-02						
213	Molybdenum as Mo Insoluble Compounds	7439-98-7	10,000	100	5.03E-01	4.00E+00	1.31E-04	3.04E+04	1.00E-01	8.75E-05	4.57E+04	3.04E+04
214	Molybdenum as Mo Soluble Compounds	7439-98-7	5,000	50	2.52E-01	2.00E+00	2.50E-11	7.99E+10	1.00E-01	8.75E-05	2.28E+04	2.28E+04
215	Morpholine	110-91-8	70,000	700	3.52E+00	2.80E+01						
216	n,n-Dimethyl Acetamide	127-19-5	35,000	350	1.76E+00	1.40E+01						
217	n,n-Dimethylamine	121-69-7	25,000	250	1.26E+00	9.99E+00						
218	n,n-Dimethylformamide	68-12-2	30,000	300	1.51E+00	1.20E+01			1.26E+01	1.10E-02	1.09E+03	1.09E+03
219	n-Amyl Acetate	628-63-7	525,000	5,250	2.64E+01	2.10E+02	6.25E-03	3.36E+04				3.36E+04
220	n-Butyl Acetate	123-86-4	710,000	7,100	3.57E+01	2.84E+02	3.35E-03	8.47E+04				8.47E+04
221	n-Butyl Acrylate	141-32-2	52,000	520	2.62E+00	2.08E+01						
222	n-Butyl Alcohol	71-36-3	150,000	1,500	7.55E+00	5.99E+01	2.08E-03	2.89E+04				2.89E+04
223	n-Butyl Glycidyl Ether	2426-08-6	133,000	1,330	6.70E+00	5.31E+01	1.27E-04	4.18E+05				4.18E+05
224	n-Butylamine	109-73-9	15,000	150	7.55E-01	5.99E+00						
225	n-Heptane	142-82-5	1,640,000	16,400	8.26E+01	6.55E+02	3.98E-03	1.65E+05				1.65E+05
226	n-Hexane	110-54-3	176,000	1,760	8.86E+00	7.03E+01	4.77E-02	1.48E+03	2.04E+01	1.78E-02	3.94E+03	1.48E+03
227	n-Methylamine	100-61-8	2,000	20	1.01E-01	7.99E-01						
228	n-Propyl Acetate	109-60-4	835,000	8,350	4.20E+01	3.34E+02						
229	Naphtalene	91-20-3	50,000	500	2.52E+00	2.00E+01						

TABLE 1 (PART A).—8-Hour SLEVs of the Toxic (Noncarcinogenic and Carcinogenic) Air Pollutants from TA-3 Facilities Based on RAPS-90 (LANL 1990) and ACIS 1995 (LANL 1995a) Data-Continued

NO.	TOXIC AIR POLLUTANTS	CAS NUMBER	OELS $\mu\text{g}/\text{m}^3$	1/100 OF THE OELS $\mu\text{g}/\text{m}^3$	8-HOUR SLEVs		RAPS 1990 DATA		ACIS 1995 DATA			THE SMALLER (R ¹) OR (R ²) RATIO
					g/sec	lb/hr	HOURLY EMISSION RATE FROM RAPS (Q ^{hr}) lb/hr	RATIO SLEVs/Q ^{hr} (R ¹)	PURCHASED AMOUNT OF CHEMICALS FROM ACIS lb/year	ESTIMATED HOURLY EMISSION RATES (Q ^{hr}) lb/hr	RATIO SLEVs/Q ^{hr} (R ²)	
1	2	3	4	5	6	7	8	9	10	11	12	13
230	Nickel Carbonyl, as Ni	13463-39-3	7	0.1	3.52E-04	2.80E-03						
231	Nickel, soluble & inorg. comp., as Ni	7440-02-0	100	1	5.03E-03	4.00E-02	7.53E-06	5.31E+03	1.70E+00	1.49E-03	2.69E+01	2.69E+01
232	Nicotine	54-11-5	500	5	2.52E-02	2.00E-01						
233	Nitric Acid	7697-32-2	5,000	50	2.52E-01	2.00E+00	4.87E-01	4.10E+00	6.20E+02	5.43E-01	3.68E+00	3.68E+00
234	Nitric Oxide	10102-43-9	30,000	300	1.51E+00	1.20E+01	1.02E-02	1.17E+03				1.17E+03
235	Nitrobenzene	98-95-3	5,000	50	2.52E-01	2.00E+00						
236	Nitroethane	79-24-3	3,070,000	30,700	1.55E+02	1.23E+03	1.20E-08	1.02E+11				1.02E+11
237	Nitromethane	75-52-5	50,000	500	2.52E+00	2.00E+01	1.20E-08	1.66E+09				1.66E+09
238	Nitrotoluene	99-99-0	11,000	110	5.54E-01	4.40E+00						
239	Nitrous Oxide	10024-97-2	90,000	900	4.53E+00	3.60E+01	1.50E-03	2.39E+04				2.39E+04
240	Nonane	111-84-2	1,050,000	10,500	5.29E+01	4.20E+02						
241	o-Chlorostyrene	2039-87-4	283,000	2,830	1.42E+01	1.13E+02						
242	o-Chlorotoluene	95-49-8	250,000	2,500	1.26E+01	9.99E+01						
243	o-Dichlorobenzene	95-50-1	150,000	1,500	7.55E+00	5.99E+01			2.87E+00	2.51E-03	2.39E+04	2.39E+04
244	o-Methylcyclohexanone	583-60-8	234,000	2,340	1.18E+01	9.35E+01						
245	o-Phenylenediamine	95-54-5	100	1	5.03E-03	4.00E-02						
246	o-Toluidine	95-53-4	8,800	88	4.43E-01	3.52E+00						
247	Octane	111-65-9	1,400,000	14,000	7.05E+01	5.59E+02	2.50E-03	2.24E+05				2.24E+05
248	Oil Mist, Mineral	NA	5,000	50	2.52E-01	2.00E+00	2.45E-02	8.16E+01				8.16E+01
249	Osmium Tetroxide, as Os	20816-12-0	2	0.02	8.06E-05	6.39E-04						
250	Oxalic Acid	144-62-7	1,000	10	5.03E-02	4.00E-01	5.25E-04	7.61E+02	3.30E+00	2.89E-03	1.38E+02	1.38E+02
251	p-Nitroaniline	100-01-6	3,000	30	1.51E-01	1.20E+00						

TABLE 1 (PART A).—8-Hour SLEVs of the Toxic (Noncarcinogenic and Carcinogenic) Air Pollutants from TA-3 Facilities Based on RAPS-90 (LANL 1990) and ACIS 1995 (LANL 1995a) Data-Continued

NO.	TOXIC AIR POLLUTANTS	CAS NUMBER	OELS $\mu\text{g}/\text{m}^3$	1/100 OF THE OELS $\mu\text{g}/\text{m}^3$	8-HOUR SLEVS		RAPS 1990 DATA		ACIS 1995 DATA			THE SMALLER (R ¹) OR (R ²) RATIO
					g/sec	lb/hr	HOURLY EMISSION RATE FROM RAPS (Q ^{hr})	RATIO SLEVS/Q ^{hr} (R ¹)	PURCHASED AMOUNT OF CHEMICALS FROM ACIS	ESTIMATED HOURLY EMISSION RATES (Q ^{hr})	RATIO SLEVS/Q ^{hr} (R ²)	
1	2	3	4	5	6	7	8	9	10	11	12	13
252	p-Nitrochlorobenzene	100-00-5	640	6	3.22E-02	2.56E-01						
253	p-Phenylenediamine	106-50-3	100	1	5.03E-03	4.00E-02						
254	p-Toluidine	106-49-0	8,800	88	4.43E-01	3.52E+00						
255	Paraffin Wax Fume	8002-74-2	2,000	20	1.01E-01	7.99E-01	2.50E-05	3.20E+04				3.20E+04
256	Paraquat Dichloride	1910-42-5	100	1	5.03E-03	4.00E-02						
257	Paraquat Respirable Sizes	4685-14-7	100	1	5.03E-03	4.00E-02						
258	Particulate Matter, Respirable Dust	NA	3,000	30.00	1.51E-01	1.20E+00	3.08E-03	3.89E+02				3.89E+02
259	Pentachlorophenol	87-86-5	500	5	2.52E-02	2.00E-01						
260	Pentaerythritol	115-77-5	5,000	50	2.52E-01	2.00E+00						
261	Pentane (all isomers)	109-66-0	1,770,000	17,700	8.91E+01	7.07E+02	6.25E-04	1.13E+06	5.56E+00	4.86E-03	1.45E+05	1.45E+05
262	Perchloromethyl Mercaptan	594-42-3	760	8	3.83E-02	3.04E-01						
263	Phenol	108-95-2	19,000	190	9.57E-01	7.59E+00	1.25E-04	6.07E+04				6.07E+04
264	Phenothiazine	92-84-2	5,000	50	2.52E-01	2.00E+00						
265	Phenyl Mercaptan	108-98-5	2,300	23	1.16E-01	9.19E-01						
266	Phenyldiazine	100-63-0	440	4	2.22E-02	1.76E-01	2.50E-06	7.03E+04				7.03E+04
267	Phenylphosphine	638-21-1	230	2	1.16E-02	9.19E-02						
268	Phosgene	75-44-5	400	4	2.01E-02	1.60E-01						
269	Phosphoric Acid	7664-38-2	1,000	10	5.03E-02	4.00E-01	2.39E-03	1.67E+02	1.82E+01	1.59E-02	2.51E+01	2.51E+01
270	Phosphorus	7723-14-0	100	1	5.03E-03	4.00E-02			1.00E-01	8.75E-05	4.57E+02	4.57E+02
271	Phosphorus Oxide	10025-87-3	600	6	3.02E-02	2.40E-01	1.25E-03	1.92E+02				1.92E+02
272	Phosphorus Pentachloride	10026-13-8	850	9	4.28E-02	3.40E-01	2.50E-04	1.36E+03				1.36E+03
273	Phosphorus Trichloride	7719-12-2	1,100	11	5.54E-02	4.40E-01						

TABLE 1 (PART A).—8-Hour SLEVs of the Toxic (Noncarcinogenic and Carcinogenic) Air Pollutants from TA-3 Facilities Based on RAPS-90 (LANL 1990) and ACIS 1995 (LANL 1995a) Data-Continued

NO.	TOXIC AIR POLLUTANTS	CAS NUMBER	OELS $\mu\text{g}/\text{m}^3$	1/100 OF THE OELS $\mu\text{g}/\text{m}^3$	8-HOUR SLEVS		RAPS 1990 DATA		ACIS 1995 DATA				THE SMALLER (R ¹) OR (R ²) RATIO
					g/sec	lb/hr	HOURLY EMISSION RATE FROM RAPS (Q ^{hr}) lb/hr	RATIO SLEVS/Q ^{hr} (R ¹)	PURCHASED AMOUNT OF CHEMICALS FROM ACIS lb/year	ESTIMATED HOURLY EMISSION RATES (Q ^{hr}) lb/hr	RATIO SLEVS/Q ^{hr} (R ²)		
												6	
1	2	3	4	5	6	7	8	9	10	11	12	13	
274	Picric Acid	88-89-1	100	1	5.03E-03	4.00E-02							
275	Platinum Metal	7440-06-4	1,000	10	5.03E-02	4.00E-01	2.50E-06	1.60E+05				1.60E+05	
276	Potassium Hydroxide	1310-58-3	2,000	20	1.01E-01	7.99E-01	7.80E-04	1.02E+03	3.96E+01	3.47E-02	2.31E+01	2.31E+01	
277	Propane	74-98-6	1,800,000	18,000	9.06E+01	7.19E+02			2.11E+04	1.85E+01	3.89E+01	3.89E+01	
278	Propargyl Alcohol	107-19-7	2,000	20	1.01E-01	7.99E-01							
279	Propionic Acid	79-09-4	30,000	300	1.51E+00	1.20E+01							
280	Protonitrile	107-12-0	14,000	140	7.05E-01	5.59E+00							
281	Propyl Alcohol	71-23-8	492,000	4,920	2.48E+01	1.97E+02	2.50E-02	7.87E+03				7.87E+03	
282	Propylene Glycol Monomethyl Ether	107-98-2	369,000	3,690	1.86E+01	1.47E+02	5.50E-09	2.68E+10				2.68E+10	
283	Pyridine	110-86-1	15,000	150	7.55E-01	5.99E+00			6.48E+00	5.67E-03	1.06E+03	1.06E+03	
284	Rhodium Metal	7440-16-6	100	1	5.03E-03	4.00E-02							
285	sec-Butyl Acetate	105-46-4	950,000	9,500	4.78E+01	3.80E+02							
286	sec-Butyl Alcohol	78-92-2	300,000	3,000	1.51E+01	1.20E+02	6.25E-04	1.92E+05				1.92E+05	
287	Selenium Compounds, as Se	7782-49-2	200	2	1.01E-02	7.99E-02	5.00E-10	1.60E+08				1.60E+08	
288	Silica, Cristobalite	14464-64-1	50	0.5	2.52E-03	2.00E-02	2.50E-05	7.99E+02				7.99E+02	
289	Silica, Quartz	14808-60-7	100	1	5.03E-03	4.00E-02	2.50E-04	1.60E+02	2.64E+01	2.31E-02	1.73E+00	1.73E+00	
290	Tridymite, Respirable Dust	15468-32-3	50	0.5	2.52E-03	2.00E-02	2.50E-06	7.99E+03				7.99E+03	
291	Silica, Fused (respirable)	60676-86-0	100	1	5.03E-03	4.00E-02	2.56E-03	1.56E+01	1.00E-01	8.75E-05	4.57E+02	1.56E+01	
292	Silicon Tetrahydride	7803-62-5	6,600	66	3.32E-01	2.64E+00							
293	Silver (metal dust & soluble comp., as Ag)	7440-22-4	100	1	5.03E-03	4.00E-02	5.11E-05	7.82E+02	1.10E+00	9.63E-04	4.15E+01	4.15E+01	

TABLE 1 (PART A).—8-Hour SLEVs of the Toxic (Noncarcinogenic and Carcinogenic) Air Pollutants from TA-3 Facilities Based on RAPS-90 (LANL 1990) and ACIS 1995 (LANL 1995a) Data-Continued

NO.	TOXIC AIR POLLUTANTS	CAS NUMBER	OELS $\mu\text{g}/\text{m}^3$	1/100 OF THE OELS $\mu\text{g}/\text{m}^3$	8-HOUR SLEVS		RAPS 1990 DATA		ACIS 1995 DATA			THE SMALLER (R ¹) OR (R ²) RATIO
					g/sec	lb/hr	HOURLY EMISSION RATE FROM RAPS (Q ^{hr})	RATIO SLEVS/Q ^{hr} (R ¹)	PURCHASED AMOUNT OF CHEMICALS FROM ACIS	ESTIMATED HOURLY EMISSION RATES (Q ^{hr})	RATIO SLEVS/Q ^{hr} (R ²)	
1	2	3	4	5	6	7	8	9	10	11	12	13
294	Stoddard Solvent	8052-41-3	525,000	5,250	2.64E+01	2.10E+02	2.44E-01	8.59E+02				8.59E+02
295	Sulfur Hexafluoride	2551-62-4	5,970,000	59,700	3.01E+02	2.39E+03			1.27E+03	1.11E+00		2.15E+03
296	Sulfuric Acid	7664-93-9	1,000	10	5.03E-02	4.00E-01	7.91E-02	5.05E+00	1.57E+02	1.37E-01		2.92E+00
297	Sulfuryl Fluoride	2699-79-8	20,000	200	1.01E+00	7.99E+00						
298	Tantalum Metal	7440-25-7	5,000	50	2.52E-01	2.00E+00	1.13E-04	1.77E+04				1.77E+04
299	Tellurium & Compounds, as Te	13494-80-9	200	2	1.01E-02	7.99E-02						
300	Terphenyls	26140-60-3	5,000	50	2.52E-01	2.00E+00						
301	tert-Butyl Alcohol	75-65-0	300,000	3,000	1.51E+01	1.20E+02	1.05E-04	1.14E+06				1.14E+06
302	Tetraethyl Lead	78-00-2	75	1	3.78E-03	3.00E-02						
303	Tetrahydrofuran	109-99-9	590,000	5,900	2.97E+01	2.36E+02	4.50E-04	5.24E+05	3.92E+00	3.43E-03		6.86E+04
304	Tetranitromethane	509-14-8	40	0	2.01E-03	1.60E-02						
305	Tetrasodium Pyrophosphate	7722-88-5	5,000	50	2.52E-01	2.00E+00						
306	Thioglycolic Acid	68-11-1	3,800	38	1.91E-01	1.52E+00						
307	Thionyl Chloride	7719-09-7	4,900	49	2.47E-01	1.96E+00			3.62E-01	3.16E-04		6.19E+03
308	Tin, metal	7440-31-5	2,000	20	1.01E-01	7.99E-01	1.60E-04	4.99E+03				4.99E+03
309	Tin Organic Compounds, as Sn	7440-31-5	100	1	5.03E-03	4.00E-02						
310	Tin Oxide & Inorganic Compounds, as Sn	7440-31-5	2,000	20	1.01E-01	7.99E-01	5.00E-10	1.60E+09	1.97E+00	1.72E-03		4.63E+02
311	Toluene	108-88-3	188,000	1,880	9.47E+00	7.51E+01	1.36E-02	5.54E+03	2.01E+01	1.76E-02		4.26E+03
312	Toluene-2,4-diisocyanate	584-84-9	20	0.20	1.01E-03	7.99E-03			2.00E-01	1.75E-04		4.57E+01
313	Tributyl Phosphate	126-73-8	2,200	22	1.11E-01	8.79E-01	2.50E-03	3.52E+02	2.16E-01	1.89E-04		3.52E+02

TABLE 1 (PART A).—8-Hour SLEVs of the Toxic (Noncarcinogenic and Carcinogenic) Air Pollutants from TA-3 Facilities Based on RAPS-90 (LANL 1990) and ACIS 1995 (LANL 1995a) Data-Continued

NO.	TOXIC AIR POLLUTANTS	CAS NUMBER	OELS $\mu\text{g}/\text{m}^3$	1/100 OF THE OELS $\mu\text{g}/\text{m}^3$	8-HOUR SLEVS		RAPS 1990 DATA		ACIS 1995 DATA				THE SMALLER (R ¹) OR (R ²) RATIO
					g/sec	lb/hr	HOURLY EMISSION RATE FROM RAPS (Q ^{hr})	RATIO SLEVS/Q ^{hr} (R ¹)	PURCHASED AMOUNT OF CHEMICALS FROM ACIS	ESTIMATED HOURLY EMISSION RATES (Q ^{hr})	RATIO SLEVS/Q ^{hr} (R ²)		
1	2	3	4	5	6	7	8	9	10	11	12	13	
314	Trichloroacetic Acid	76-03-9	6,700	67	3.37E-01	2.68E+00	2.53E-04	1.06E+04				1.06E+04	
315	Triethylamine	121-44-8	4,100	41	2.06E-01	1.64E+00			4.83E-01	4.23E-04		3.88E+03	
316	Trimethyl Benzene	25551-13-7	123,000	1,230	6.19E+00	4.91E+01							
317	Trimethyl Phosphite	121-45-9	10,000	100	5.03E-01	4.00E+00							
318	Trimethylamine	75-50-3	12,000	120	6.04E-01	4.79E+00							
319	Triphenylamine	603-34-9	5,000	50	2.52E-01	2.00E+00							
320	Triphenylphosphate	115-86-6	3,000	30	1.51E-01	1.20E+00							
321	Tungsten as W insoluble Compounds	7440-33-7	5,000	50	2.52E-01	2.00E+00	6.02E-01	3.32E+00				3.32E+00	
322	Turpentine	8006-64-2	556,000	5,560	2.80E+01	2.22E+02	4.35E-02	5.11E+03				5.11E+03	
323	Uranium (natural) Sol. & Unsol. Comp. as U	7440-61-1	50	1	2.52E-03	2.00E-02	5.00E-10	4.00E+07	1.98E-01	1.74E-04	1.15E+02	1.15E+02	
324	Vanadium, Respirable Dust & Fume	1314-62-1	50	1	2.52E-03	2.00E-02	2.50E-10	7.99E+07	1.10E+00	9.63E-04	2.08E+01	2.08E+01	
325	Vinyl Acetate	108-05-4	35,000	350	1.76E+00	1.40E+01	2.50E-03	5.59E+03				5.59E+03	
326	Vinyl Toluene	25013-15-4	242,000	2,420	1.22E+01	9.67E+01							
327	Vinylidene Fluoride	75-38-7	2,660	27	1.34E-01	1.06E+00							
328	VM & P Naphtha	8032-32-4	1,370,000	13,700	6.90E+01	5.47E+02	3.52E-02	1.56E+04	1.65E+00	1.45E-03	3.78E+05	1.56E+04	
329	Welding Fumes not otherwise listed	NA	5,000	50	2.52E-01	2.00E+00	1.95E+00	1.03E+00				1.03E+00	
330	Wood Dust (certain hard woods)	NA	1,000	10	5.03E-02	4.00E-01	2.51E+00	1.60E-01				1.60E-01	
331	Xylene (o-, m-, p-Isomers)	1330-20-7	434,000	4,340	2.19E+01	1.73E+02	1.20E-01	1.45E+03	1.31E+01	1.14E-02	1.51E+04	1.45E+03	
332	Yttrium	7440-65-5	1,000	10	5.03E-02	4.00E-01	9.63E-04	4.15E+02	1.00E-01	8.75E-05	4.57E+03	4.15E+02	

TABLE 1 (PART A).—8-Hour SLEVs of the Toxic (Noncarcinogenic and Carcinogenic) Air Pollutants from TA-3 Facilities Based on RAPS-90 (LANL 1990) and ACIS 1995 (LANL 1995a) Data-Continued

NO.	TOXIC AIR POLLUTANTS	CAS NUMBER	OELS $\mu\text{g}/\text{m}^3$	1/100 OF THE OELS $\mu\text{g}/\text{m}^3$	8-HOUR SLEVS		RAPS 1990 DATA		ACIS 1995 DATA			THE SMALLER (R ¹) OR (R ²) RATIO
					g/sec	lb/hr	HOURLY EMISSION RATE FROM RAPS (Q ^{hr})	RATIO SLEVS/Q ^{hr} (R ¹)	PURCHASED AMOUNT OF CHEMICALS FROM ACIS	ESTIMATED HOURLY EMISSION RATES (Q ^{hr})	RATIO SLEVS/Q ^{hr} (R ²)	
1	2	3	4	5	6	7	8	9	10	11	12	13
333	Zinc Chloride Fume	7646-85-7	1,000	10	5.03E-02	4.00E-01	5.05E-03	7.91E+01	6.00E-01	5.25E-04	7.61E+02	7.91E+01
334	Zinc Oxide Fume	1314-13-2	5,000	50	2.52E-01	2.00E+00	3.65E-04	5.48E+03				5.48E+03
335	Zinc Chromate, as Cr	13530-65-9	10	0.1	5.03E-04	4.00E-03						
336	Zirconium Compounds, as Zr	7440-67-7	5,000	50	2.52E-01	2.00E+00	9.00E-04	2.22E+03				2.22E+03
CARCINOGENIC POLLUTANTS												
337	Acrylamide	79-06-1	30	0.3	1.51E-03	1.20E-02			6.00E-01	5.25E-04	2.28E+01	2.28E+01
338	Acrylonitrile	107-13-1	4,300	43	2.16E-01	1.72E+00						
339	Allyl Chloride	107-05-1	3,000	30	1.51E-01	1.20E+00						
340	Aldrin	309-00-2	250	3	1.26E-02	9.99E-02						
341	Arsenic, el. & inorg., exc. Arsenic, as As	7440-38-2	10	0.1	5.03E-04	4.00E-03	5.00E-10	7.99E+06				7.99E+06
342	Benzene	71-43-2	3,000	30	1.51E-01	1.20E+00						
343	Benzyl Chloride	100-44-7	2,800	28	1.41E-01	1.12E+00						
344	Beryllium	7440-41-7	2	0.02	1.01E-04	7.99E-04	3.01E-06	2.66E+02				2.66E+02
345	Bromoform	75-25-2	5,000	50	2.52E-01	2.00E+00						
346	1,3-Butadiene	106-99-0	4,400	44	2.22E-01	1.76E+00						
347	Cadmium, el. & compounds, as Cd	7440-43-9	2	0.02	1.01E-04	7.99E-04	6.60E-05	1.21E+01				1.21E+01
348	Carbon Tetrachloride	56-23-5	31,000	310	1.56E+00	1.24E+01	4.01E-02	3.09E+02				3.09E+02
349	Chloroform	67-66-3	49,000	490	2.47E+00	1.96E+01	4.55E-02	4.30E+02	1.44E+02	1.26E-01	1.56E+02	1.56E+02
350	Chromic acids & chromates	1333-82-0	1	0.01	5.03E-05	4.00E-04	8.06E-04	4.96E-01	3.00E-01	2.63E-04	1.52E+00	4.96E-01
351	Diethanolamine	111-42-2	200	2	1.01E-02	7.99E-02						

TABLE 1 (PART A).—8-Hour SLEVs of the Toxic (Noncarcinogenic and Carcinogenic) Air Pollutants from TA-3 Facilities Based on RAPS-90 (LANL 1990) and ACIS 1995 (LANL 1995a) Data-Continued

NO.	TOXIC AIR POLLUTANTS	CAS NUMBER	OELS $\mu\text{g}/\text{m}^3$	1/100 OF THE OELS $\mu\text{g}/\text{m}^3$	8-HOUR SLEVS		RAPS 1990 DATA		ACIS 1995 DATA			THE SMALLER (R ¹) OR (R ²) RATIO
					g/sec	lb/hr	HOURLY EMISSION RATE FROM RAPS (Q ^{hr})	RATIO SLEVS/Q ^{hr} (R ¹)	PURCHASED AMOUNT OF CHEMICALS FROM ACIS	ESTIMATED HOURLY EMISSION RATES (Q ^{hr})	RATIO SLEVS/Q ^{hr} (R ²)	
1	2	3	4	5	6	7	8	9	10	11	12	13
352	Epichlorohydrin	106-89-8	7,600	76	3.83E-01	3.04E+00						
353	Ethyl Acrylate	140-88-5	20,000	200	1.01E+00	7.99E+00			6.09E-01	5.33E-04	1.50E+04	1.50E+04
354	Ethylene Dichloride	107-06-2	40,000	400	2.01E+00	1.60E+01						
355	Ethylene Oxide	75-21-8	1,800	18	9.06E-02	7.19E-01						
356	Hexachlorobenzene	118-74-1	25	0.25	1.26E-03	9.99E-03						
357	Hexachlorobutadiene	87-68-3	210	2	1.06E-02	8.39E-02						
358	Hexachloroethane	67-72-1	9,700	97	4.88E-01	3.88E+00						
359	Hydrazine	302-01-2	13	0.1	6.54E-04	5.19E-03			2.00E-01	1.75E-04	2.97E+01	2.97E+01
360	Lindane	58-89-9	500	5	2.52E-02	2.00E-01						
361	Methyl Chloride	74-87-3	103,000	1,030	5.19E+00	4.12E+01	1.10E-01	3.74E+02				3.74E+02
362	Methylene Chloride	75-09-2	174,000	1,740	8.76E+00	6.95E+01	3.76E-02	1.85E+03	1.73E+02	1.51E-01	4.59E+02	4.59E+02
363	Nickel, metal (dust)	7440-02-0	1,000	10	5.03E-02	4.00E-01	3.01E-01	1.33E+00				1.33E+00
364	Pentachlorophenol	87-86-5	500	5	2.52E-02	2.00E-01						
365	Polychlorinated Biphenyl (PCB)	11097-69-1	500	5	2.52E-02	2.00E-01						
366	Propylene Dichloride	78-87-5	347,000	3,470	1.75E+01	1.39E+02	1.38E-02	1.01E+04				1.01E+04
367	Propylene Oxide	75-56-9	48,000	480	2.42E+00	1.92E+01						
368	Styrene	100-42-5	213,000	2,130	1.07E+01	8.51E+01						
369	Toxaphene	8001-35-2	500	5	2.52E-02	2.00E-01						
370	Tetrachlorethylene	127-18-4	170,000	1,700	8.56E+00	6.79E+01	2.50E-03	2.72E+04	2.25E+00	1.97E-03	5.45E+04	2.72E+04
371	Trichloroethylene	79-01-6	269,000	2,690	1.35E+01	1.07E+02	1.40E-01	7.68E+02				7.68E+02
372	Vinyl Chloride	75-01-4	13,000	130	6.54E-01	5.19E+00						
373	1,1-Dichloroethylene	75-35-4	20,000	200	1.01E+00	7.99E+00						

TABLE 1 (PART A).—8-Hour SLEVs of the Toxic (Noncarcinogenic and Carcinogenic) Air Pollutants from TA-3 Facilities Based on RAPS-90 (LANL 1990) and ACIS 1995 (LANL 1995a) Data-Continued

NO.	TOXIC AIR POLLUTANTS	CAS NUMBER	OELS $\mu\text{g}/\text{m}^3$	1/100 OF THE OELS $\mu\text{g}/\text{m}^3$	8-HOUR SLEVS		RAPS 1990 DATA		ACIS 1995 DATA			THE SMALLER (R^1) OR (R^2) RATIO
					g/sec	lb/hr	HOURLY EMISSION RATE FROM RAPS (Q^{hr})	RATIO SLEVS/ Q^{hr} (R^1)	PURCHASED AMOUNT OF CHEMICALS FROM ACIS	ESTIMATED HOURLY EMISSION RATES (Q^{hr})	RATIO SLEVS/ Q^{hr} (R^2)	
						lb/year	lb/hr	lb/hr	lb/year	lb/hr	lb/hr	
1	2	3	4	5	6	7	8	9	10	11	12	13
374	1,1,2,2-Tetrachloroethane	79-34-5	6,900	69	3.47E-01	2.76E+00						
375	1,1,2-Trichloroethane	79-00-5	45,000	450	2.27E+00	1.80E+01	3.10E+00	5.81E+00				5.81E+00
376	2-Nitropropane	79-46-9	36,000	360	1.81E+00	1.44E+01						

Note: The highest ISC-3 estimated concentration at fence line receptors around TA-3 was found to be 198.63 $\mu\text{g}/\text{m}^3$ when emission rate is 1 g/sec. NA = Not applicable, OELs = occupational exposure limits, RAPS = regulated air pollutants (reports), ACIS = Automated Chemical Inventory System

TABLE 1 (PART B).—8-Hour SLEVs of the Potentially Sensitive Toxic Air Pollutants (Noncarcinogenic and Carcinogenic) from TA-3 Facilities Based on RAPS-90 (LANL 1990) and ACIS 1995 (LANL 1995a) Data

NO.	TOXIC AIR POLLUTANTS	CAS NUMBER	OELS $\mu\text{g}/\text{m}^3$	1/100 OF THE OELS $\mu\text{g}/\text{m}^3$	8-HOUR SLEVS		RAPS 1990 DATA		ACIS 1995 DATA				THE SMALLER (R ¹) OR (R ²) RATIO
					g/sec	lb/hr	HOURLY EMISSION RATE FROM RAPS (Q ^{hr})	RATIO SLEVS/Q ^{hr} (R ¹)	PURCHASED AMOUNT OF CHEMICALS FROM ACIS	ESTIMATED HOURLY EMISSION RATES (Q ^{hr})	RATIO SLEVS/Q ^{hr} (R ²)		
												lb/year	
1	2	3	4	5	6	7	8	9	10	11	12	13	
NONCARCINOGENIC POLLUTANTS													
1	2-Butoxyethanol	111-76-2	121,000	1,210	6.09E+00	4.83E+01	5.11E-01	9.47E+01					9.47E+01
2	Acetic Acid	64-19-7	25,000	250	1.26E+00	9.99E+00	2.84E+00	3.51E+00	1.62E+01	1.42E-02	7.04E+02	3.51E+00	3.51E+00
3	Aluminum, Metal Dust, as Al	7429-90-5	10,000	100	5.03E-01	4.00E+00	4.09E-02	9.78E+01	2.20E+00	1.93E-03	2.08E+03	9.78E+01	9.78E+01
4	Aluminum, Welding Fumes, as Al	7429-90-5	5,000	50	2.52E-01	2.00E+00	6.04E-01	3.31E+00					3.31E+00
5	Ammonia	7664-41-7	17,000	170	8.56E-01	6.79E+00	7.09E-01	9.59E+00					9.59E+00
6	Carbon Black	1333-86-4	3,500	35	1.76E-01	1.40E+00	1.47E-02	9.49E+01	1.10E+00	9.63E-04	1.45E+03	9.49E+01	9.49E+01
7	Diethylene Triamine	111-40-0	1,000	10	5.03E-02	4.00E-01		6.05E+00	6.05E+00	5.30E-03	7.55E+01	7.55E+01	7.55E+01
8	Fluorides, as F	NA	2,500	25	1.26E-01	9.99E-01	1.33E-02	7.49E+01					7.49E+01
9	Hydrogen Chloride	7647-01-0	7,000	70	3.52E-01	2.80E+00	5.36E-01	5.22E+00	5.27E+02	4.61E-01	6.07E+00	5.22E+00	5.22E+00
10	Hydrogen Fluoride, as F	7664-39-3	2,300	23	1.16E-01	9.19E-01	1.20E-02	7.67E+01	2.74E+01	2.39E-02	3.84E+01	3.84E+01	3.84E+01
11	Hydrogen Peroxide	7722-84-1	1,400	14	7.05E-02	5.59E-01	1.28E-02	4.37E+01	7.47E+01	6.53E-02	8.56E+00	8.56E+00	8.56E+00
12	Indium & compounds, as In	7440-74-6	100	1	5.03E-03	4.00E-02			6.00E-01	5.25E-04	7.61E+01	7.61E+01	7.61E+01
13	Kerosene	8008-20-6	100,000	1,000	5.03E+00	4.00E+01	9.75E-01	4.10E+01	1.00E+02	8.75E-02	4.57E+02	4.10E+01	4.10E+01
14	Lithium Hydride	7580-67-8	25	0.25	1.26E-03	9.99E-03	1.02E-02	9.82E-01					9.82E-01
15	Nickel, soluble & inorg. comp., as Ni	7440-02-0	100	1	5.03E-03	4.00E-02	7.53E-06	5.31E+03	1.70E+00	1.49E-03	2.69E+01	2.69E+01	2.69E+01
16	Nitric Acid	7697-32-2	5,000	50	2.52E-01	2.00E+00	4.87E-01	4.10E+00	6.20E+02	5.43E-01	3.68E+00	3.68E+00	3.68E+00
17	Oil Mist, Mineral	NA	5,000	50	2.52E-01	2.00E+00	2.45E-02	8.16E+01					8.16E+01

TABLE 1 (PART B).—8-Hour SLEVs of the Potentially Sensitive Toxic Air Pollutants (Noncarcinogenic and Carcinogenic) from TA-3 Facilities Based on RAPS-90 (LANL 1990) and ACIS 1995 (LANL 1995a) Data-Continued

NO.	TOXIC AIR POLLUTANTS	CAS NUMBER	OELS $\mu\text{g}/\text{m}^3$	1/100 OF THE OELS $\mu\text{g}/\text{m}^3$	8-HOUR SLEVS		RAPS 1990 DATA		ACIS 1995 DATA				THE SMALLER (R ¹) OR (R ²) RATIO
					g/sec	lb/hr	HOURLY EMISSION RATE FROM RAPS (Q ^{hr})	RATIO SLEVS/Q ^{hr} (R ¹)	PURCHASED AMOUNT OF CHEMICALS FROM ACIS	ESTIMATED HOURLY EMISSION RATES (Q ^{ha})	RATIO SLEVS/Q ^{ha} (R ²)		
												lb/year	
1	2	3	4	5	6	7	8	9	10	11	12	13	
18	Phosphoric Acid	7664-38-2	1,000	10	5.03E-02	4.00E-01	2.39E-03	1.67E+02	1.82E+01	1.59E-02	2.51E+01	2.51E+01	
19	Potassium Hydroxide	1310-58-3	2,000	20	1.01E-01	7.99E-01	7.80E-04	1.02E+03	3.96E+01	3.47E-02	2.31E+01	2.31E+01	
20	Propane	74-98-6	1,800,000	18,000	9.06E+01	7.19E+02			2.11E+04	1.85E+01	3.89E+01	3.89E+01	
21	Silica, Quartz	14808-60-7	100	1	5.03E-03	4.00E-02	2.50E-04	1.60E+02	2.64E+01	2.31E-02	1.73E+00	1.73E+00	
22	Silica, Fused (respirable)	60676-86-0	100	1	5.03E-03	4.00E-02	2.56E-03	1.56E+01	1.00E-01	8.75E-05	4.57E+02	1.56E+01	
23	Silver (metal dust & soluble comp., as Ag)	7440-22-4	100	1	5.03E-03	4.00E-02	5.11E-05	7.82E+02	1.10E+00	9.63E-04	4.15E+01	4.15E+01	
24	Sulfuric Acid	7664-93-9	1,000	10	5.03E-02	4.00E-01	7.91E-02	5.05E+00	1.57E+02	1.37E-01	2.92E+00	2.92E+00	
25	Toluene-2,4-diisocyanate	584-84-9	20	0.20	1.01E-03	7.99E-03			2.00E-01	1.75E-04	4.57E+01	4.57E+01	
26	Tungsten as W insoluble Compounds	7440-33-7	5,000	50	2.52E-01	2.00E+00	6.02E-01	3.32E+00				3.32E+00	
27	Vanadium, Respirable Dust & Fume	1314-62-1	50	1	2.52E-03	2.00E-02	2.50E-10	7.99E+07	1.10E+00	9.63E-04	2.08E+01	2.08E+01	
28	Welding Fumes not otherwise listed	NA	5,000	50	2.52E-01	2.00E+00	1.95E+00	1.03E+00				1.03E+00	
29	Wood Dust (certain hard woods)	NA	1,000	10	5.03E-02	4.00E-01	2.51E+00	1.60E-01				1.60E-01	
30	Zinc Chloride Fume	7646-85-7	1,000	10	5.03E-02	4.00E-01	5.05E-03	7.91E+01	6.00E-01	5.25E-04	7.61E+02	7.91E+01	

TABLE 1 (PART B).—8-Hour SLEVs of the Potentially Sensitive Toxic Air Pollutants (Noncarcinogenic and Carcinogenic) from TA-3 Facilities Based on RAPS-90 (LANL 1990) and ACIS 1995 (LANL 1995a) Data-Continued

NO.	TOXIC AIR POLLUTANTS	CAS NUMBER	OELS $\mu\text{g}/\text{m}^3$	1/100 OF THE OELS $\mu\text{g}/\text{m}^3$	8-HOUR SLEVS		RAPS 1990 DATA		ACIS 1995 DATA			THE SMALLER (R ¹) OR (R ²) RATIO
					g/sec	lb/hr	lb/hr	lb/hr	HOURLY EMISSION RATE FROM RAPS (Q ^{hr})	RATIO SLEVS/Q ^{hr} (R ¹)	PURCHASED AMOUNT OF CHEMICALS FROM ACIS	
1	2	3	4	5	6	7	8	9	10	11	12	13
CARCINOGENIC POLLUTANTS												
31	Acrylamide	79-06-1	30	0.3	1.51E-03	1.20E-02			6.00E-01	5.25E-04	2.28E+01	2.28E+01
32	Cadmium, el. & compounds, as Cd	7440-43-9	2	0.02	1.01E-04	7.99E-04	6.60E-05	1.21E+01				1.21E+01
33	Chromic acids & chromate's	1333-82-0	1	0.01	5.03E-05	4.00E-04	8.06E-04	4.96E-01	3.00E-01	2.63E-04	1.52E+00	4.96E-01
34	Hydrazine	302-01-2	13	0.1	6.54E-04	5.19E-03			2.00E-01	1.75E-04	2.97E+01	2.97E+01
35	Nickel, metal (dust)	7440-02-0	1,000	10	5.03E-02	4.00E-01	3.01E-01	1.33E+00				1.33E+00
36	1,1,2-Trichloroethane	79-00-5	45,000	450	2.27E+00	1.80E+01	3.10E+00	5.81E+00				5.81E+00

NA = Not applicable

TABLE 1 (PART C).—8-Hour SLEVs of Potentially Sensitive Noncarcinogenic Pollutants from Building 1 of TA-3

NO.	TOXIC AIR POLLUTANTS	CAS NUMBER	OELS $\mu\text{g}/\text{m}^3$	1/100 OF THE OELS $\mu\text{g}/\text{m}^3$	8-HOUR SLEVS		RAPS 1990 DATA		ACIS 1995 DATA			THE SMALLER (R ¹) OR (R ²) RATIO
					g/sec	lb/hr	lb/hr	lb/hr	HOURLY EMISSION RATE FROM RAPS (Q ^{hr})	RATIO SLEVS/Q ^{hr} (R ¹)	PURCHASED AMOUNT OF CHEMICALS FROM ACIS	
1	2	3	4	5	6	7	8	9	10	11	12	13
1	Propane	74-98-6	1,800,000	18,000	9.06E+01	7.19E+02			1.81E+02	1.59E-01	4.53E+03	4.53E+03

TABLE 1 (PART D).—8-Hour SLEVs of Potentially Sensitive Noncarcinogenic and Carcinogenic Pollutants from Building 16 of TA-3

NO.	TOXIC AIR POLLUTANTS	CAS NUMBER	OELS $\mu\text{g}/\text{m}^3$	1/100 OF THE OELS $\mu\text{g}/\text{m}^3$	8-HOUR SLEVS		RAPS 1990 DATA		ACIS 1995 DATA			THE SMALLER (R ¹) OR (R ²) RATIO
					g/sec	lb/hr	lb/hr	lb/hr	HOURLY EMISSION RATE FROM RAPS (Q ^{hr})	RATIO SLEVS/Q ^{hr} (R ¹)	PURCHASED AMOUNT OF CHEMICALS FROM ACIS	
1	2	3	4	5	6	7	8	9	10	11	12	13
NONCARCINOGENIC POLLUTANTS												
1	Acetic Acid	64-19-7	25,000	250	1.26E+00	9.99E+00	3.13E-04	3.20E+04				3.20E+04
2	Hydrogen Chloride	7647-01-0	7,000	70	3.52E-01	2.80E+00	5.00E-06	5.59E+05				5.59E+05
3	Nitric Acid	7697-32-2	5,000	50	2.52E-01	2.00E+00	5.00E-04	4.00E+03				4.00E+03
4	Welding Fumes not otherwise listed	NA	5,000	50	2.52E-01	2.00E+00	1.20E-04	1.67E+04				1.67E+04
CARCINOGENIC POLLUTANTS												
5	Chromic Acids & Chromates	1333-82-0	1	0.01	5.03E-05	4.00E-04	5.00E-05	7.99E+00				7.99E+00

TABLE 1 (PART E).—8-Hour SLEVs of Potentially Sensitive Noncarcinogenic and Carcinogenic Pollutants from Building 29 of TA-3

NO.	TOXIC AIR POLLUTANTS	CAS NUMBER	OELS $\mu\text{g}/\text{m}^3$	1/100 OF THE OELS $\mu\text{g}/\text{m}^3$	8-HOUR SLEVS		RAPS 1990 DATA		ACIS 1995 DATA			THE SMALLER (R ¹) OR (R ²) RATIO
					g/sec	lb/hr	HOURLY EMISSION RATE FROM RAPS (Q ^{hr})	RATIO SLEVS/Q ^{hr} (R ¹)	PURCHASED AMOUNT OF CHEMICALS FROM ACIS	ESTIMATED HOURLY EMISSION RATES (Q ^{hr})	RATIO SLEVS/Q ^{hr} (R ²)	
					lb/hr	lb/hr	lb/hr	lb/hr	lb/year	lb/hr	lb/hr	
1	2	3	4	5	6	7	8	9	10	11	12	13
NONCARCINOGENIC POLLUTANTS												
1	Acetic Acid	64-19-7	25,000	250	1.26E+00	9.99E+00	1.25E-03	7.99E+03	1.27E+01	1.11E-02	8.97E+02	8.97E+02
2	Ammonia	7664-41-7	17,000	170	8.56E-01	6.79E+00	8.80E-04	7.72E+03				7.72E+03
3	Fluorides, as F	NA	2,500	25	1.26E-01	9.99E-01	1.33E-02	7.49E+01				7.49E+01
4	Hydrogen Chloride	7647-01-0	7,000	70	3.52E-01	2.80E+00	5.13E-01	5.46E+00	2.33E+02	2.04E-01	1.37E+01	5.46E+00
5	Hydrogen Fluoride, as F	7664-39-3	2,300	23	1.16E-01	9.19E-01	1.76E-03	5.21E+02	1.37E+01	1.20E-02	7.68E+01	7.68E+01
6	Hydrogen Peroxide	7722-84-1	1,400	14	7.05E-02	5.59E-01	1.12E-02	4.99E+01	3.79E+01	3.32E-02	1.69E+01	1.69E+01
7	Kerosene	8008-20-6	100,000	1,000	5.04E+00	4.00E+01	3.13E-03	1.28E+04				1.28E+04
8	Nitric Acid	7697-32-2	5,000	50	2.52E-01	2.00E+00	3.82E-01	5.23E+00	3.77E+02	3.30E-01	6.06E+00	5.23E+00
9	Oil Mist, Mineral	NA	5,000	50	2.52E-01	2.00E+00	2.43E-03	8.23E+02				8.23E+02
10	Phosphoric Acid	7664-38-2	1,000	10	5.03E-02	4.00E-01	3.98E-04	1.01E+03	1.01E+01	8.83E-03	4.53E+01	4.53E+01
11	Potassium Hydroxide	1310-58-31	2,000	20	1.01E-01	7.99E-01	6.50E-04	1.23E+03				1.23E+03
12	Propane	74-98-6	1,800,000	18,000	9.06E+01	7.19E+02			1.21E+02	1.06E-01	6.79E+03	6.79E+03
13	Silica, Fused (respirable)	60676-86-0	100	1	5.03E-03	4.00E-02			1.00E-01	8.75E-05	4.57E+02	4.57E+02
14	Silver (metal dust & soluble comp., as Ag)	7440-22-4	100	1	5.04E-03	4.00E-02	1.25E-07	3.20E+05				3.20E+05
15	Sulfuric Acid	7664-93-9	1,000	10	5.04E-02	4.00E-01	6.29E-02	6.35E+00	1.34E+02	1.17E-01	3.41E+00	6.35E+00
16	Vanadium, Respirable Dust & Fume	1314-62-1	50	1	2.52E-03	2.00E-02	2.50E-10	7.99E+07				7.99E+07
17	Welding Fumes not otherwise listed	NA	5,000	50	2.52E-01	2.00E+00	9.44E-03	2.12E+02				2.12E+02

TABLE 1 (PART E).—8-Hour SLEVs of Potentially Sensitive Noncarcinogenic and Carcinogenic Pollutants from Building 29 of TA-3-

NO.	TOXIC AIR POLLUTANTS	CAS NUMBER	OELS $\mu\text{g}/\text{m}^3$	1/100 OF THE OELS $\mu\text{g}/\text{m}^3$	8-HOUR SLEVS		RAPS 1990 DATA		ACIS 1995 DATA			THE SMALLER (R ¹) OR (R ²) RATIO
					g/sec	lb/hr	HOURLY EMISSION RATE FROM RAPS (Q ^{hr})	RATIO SLEVS/Q ^{hr} (R ¹)	PURCHASED AMOUNT OF CHEMICALS FROM ACIS	ESTIMATED HOURLY EMISSION RATES (Q ^{ha})	RATIO SLEVS/Q ^{ha} (R ²)	
1	2	3	4	5	6	7	8	9	10	11	12	13
CARCINOGENIC POLLUTANTS												
18	Acrylamide	79-06-1	30	0.3	1.51E-03	1.20E-02			6.00E-01	5.25E-04	2.28E+01	2.28E+01
19	Cadmium, el.&compounds, as Cd	7440-43-9	2	0.02	1.01E-04	7.99E-04	6.60E-05	1.21E+01				1.21E+01
21	Chromic acids & chromate's	1333-82-0	1	0.01	5.03E-05	4.00E-04	6.31E-04	6.33E-01	2.00E-01	1.75E-04	2.28E+00	6.33E-01
22	Nickel, metal (dust)	7440-02-0	1,000	10	5.03E-02	4.00E-01	2.75E-06	1.45E+05				1.45E+05
23	1,1,2-Trichloroethane	79-00-5	45,000	450	2.27E+00	1.80E+01	4.51E-03	3.99E+03				3.99E+03

TABLE 1 (PART F).—8-Hour SLEVs of Potentially Sensitive Noncarcinogenic Pollutants from Building 22 of TA-3-

NO.	TOXIC AIR POLLUTANTS	CAS NUMBER	OELS $\mu\text{g}/\text{m}^3$	1/100 OF THE OELS $\mu\text{g}/\text{m}^3$	8-HOUR SLEVS		RAPS 1990 DATA		ACIS 1995 DATA			THE SMALLER (R ¹) OR (R ²) RATIO
					g/sec	lb/hr	HOURLY EMISSION RATE FROM RAPS (Q ^{hr})	RATIO SLEVS/Q ^{hr} (R ¹)	PURCHASED AMOUNT OF CHEMICALS FROM ACIS	ESTIMATED HOURLY EMISSION RATES (Q ^{ha})	RATIO SLEVS/Q ^{ha} (R ²)	
1	2	3	4	5	6	7	8	9	10	11	12	13
1	Sulfuric Acid	7664-93-9	1,000	10	5.04E-02	4.00E-01			1.62E+00	1.42E-03	2.81E+02	2.81E+02

TABLE 1 (PART G).—8-Hour SLEVs of Potentially Sensitive Noncarcinogenic Pollutants from Building 30 of TA-3

NO.	TOXIC AIR POLLUTANTS	CAS NUMBER	OELS $\mu\text{g}/\text{m}^3$	1/100 OF THE OELS $\mu\text{g}/\text{m}^3$	8-HOUR SLEVS		RAPS 1990 DATA		ACIS 1995 DATA			THE SMALLER (R ¹) OR (R ²) RATIO
					g/sec	lb/hr	HOURLY EMISSION RATE FROM RAPS (Q ^{hr})	RATIO SLEVS/Q ^{hr} (R ¹)	PURCHASED AMOUNT OF CHEMICALS FROM ACIS	ESTIMATED HOURLY EMISSION RATES (Q ^{ba})	RATIO SLEVS/Q ^{ba} (R ²)	
						lb/hr		lb/hr	lb/year	lb/hr		
1	2	3	4	5	6	7	8	9	10	11	12	13
1	2-Butoxyethanol	111-76-2	121,000	1,210	6.09E+00	4.84E+01	9.68E-03	5.00E+03				5.00E+03
2	Ammonia	7664-41-7	17,000	170	8.56E-01	6.79E+00	1.58E-03	4.31E+03				4.31E+03
3	Propane	74-98-6	1,800,000	18,000	9.06E+01	7.19E+02			1.02E+04	8.94E+00		8.05E+01
4	Wood Dust (certain hard woods)	NA	1,000	10	5.04E-02	4.00E-01	2.50E+00	1.60E-01				1.60E-01

TABLE 1 (PART H).—8-Hour SLEVs of Potentially Sensitive Noncarcinogenic Pollutants from Building 25 of TA-3

NO.	TOXIC AIR POLLUTANTS	CAS NUMBER	OELS $\mu\text{g}/\text{m}^3$	1/100 OF THE OELS $\mu\text{g}/\text{m}^3$	8-HOUR SLEVS		RAPS 1990 DATA		ACIS 1995 DATA			THE SMALLER (R ¹) OR (R ²) RATIO
					g/sec	lb/hr	HOURLY EMISSION RATE FROM RAPS (Q ^{hr})	RATIO SLEVS/Q ^{hr} (R ¹)	PURCHASED AMOUNT OF CHEMICALS FROM ACIS	ESTIMATED HOURLY EMISSION RATES (Q ^{ba})	RATIO SLEVS/Q ^{ba} (R ²)	
						lb/hr		lb/hr	lb/year	lb/hr		
1	2	3	4	5	6	7	8	9	10	11	12	13
1	Propane	74-98-6	1,800,000	18,000	9.06E+01	7.19E+02			2.82E+02	2.47E-01		2.91E+03

TABLE 1 (PART I).—8-Hour SLEVs of Potentially Sensitive Noncarcinogenic Pollutants from Building 32 of TA-3

NO.	TOXIC AIR POLLUTANTS	CAS NUMBER	OELS $\mu\text{g}/\text{m}^3$	1/100 OF THE OELS $\mu\text{g}/\text{m}^3$	8-HOUR SLEVS		RAPS 1990 DATA		ACIS 1995 DATA			THE SMALLER (R ¹) OR (R ²) RATIO
					g/sec	lb/hr	lb/hr	lb/hr	HOURLY EMISSION RATE FROM RAPS (Q ^{hr})	RATIO SLEVS/Q ^{hr} (R ¹)	PURCHASED AMOUNT OF CHEMICALS FROM ACIS	
1	2	3	4	5	6	7	8	9	10	11	12	13
1	Acetic Acid	64-19-7	25,000	250	1.26E+00	9.99E+00			2.32E+00	2.03E-03	4.93E+03	4.93E+03
2	Kerosene	8008-20-6	100,000	1,000	5.03E+00	4.00E+01	2.25E-03	1.78E+04				1.78E+04
3	Nitric Acid	7697-32-2	5,000	50	2.52E-01	2.00E+00	1.13E-03	1.78E+03				1.78E+03

TABLE 1 (PART J).—8-Hour SLEVs of Potentially Sensitive Noncarcinogenic and Carcinogenic Pollutants from Building 34 of TA-3

NO.	TOXIC AIR POLLUTANTS	CAS NUMBER	OELS $\mu\text{g}/\text{m}^3$	1/100 OF THE OELS $\mu\text{g}/\text{m}^3$	8-HOUR SLEVS		RAPS 1990 DATA		ACIS 1995 DATA			THE SMALLER (R ¹) OR (R ²) RATIO
					g/sec	lb/hr	HOURLY EMISSION RATE FROM RAPS (Q ^{hr})	RATIO SLEVS/Q ^{hr} (R ¹)	PURCHASED AMOUNT OF CHEMICALS FROM ACIS	ESTIMATED HOURLY EMISSION RATES (Q ^{hr})	RATIO SLEVS/Q ^{hr} (R ²)	
1	2	3	4	5	6	7	8	9	10	11	12	13
NONCARCINOGENIC POLLUTANTS												
1	Acetic Acid	64-19-7	25,000	250	1.26E+00	9.99E+00	1.25E-04	7.99E+04	1.16E+00	1.01E-03	9.86E+03	9.86E+03
2	Aluminum, Metal Dust, as Al	7429-90-5	10,000	100	5.04E-01	4.00E+00	6.25E-05	6.39E+04	1.10E+00	9.63E-04	4.15E+03	4.15E+03
3	Carbon Black	1333-86-4	3,500	35	1.76E-01	1.40E+00	2.53E-04	5.54E+03	1.04E+01	9.11E-03	3.07E+02	3.07E+02
4	Hydrogen Chloride	7647-01-0	7,000	70	3.52E-01	2.80E+00	3.75E-04	7.46E+03	3.54E+00	3.09E-03	2.97E+02	2.97E+02
5	Hydrogen Fluoride, as F	7664-39-3	2,300	23	1.16E-01	9.19E-01			2.45E+00	2.14E-03	2.61E+02	2.61E+02
6	Hydrogen Peroxide	7722-84-1	1,400	14	7.05E-02	5.59E-01	2.50E-04	2.24E+03	6.00E-01	5.25E-04	7.61E+01	7.61E+01
7	Indium & Compounds, as In	7440-74-6	100	1	5.04E-03	4.00E-02			4.29E+01	3.75E-02	1.07E+03	1.07E+03
8	Kerosene	8008-20-6	100,000	1,000	5.04E+00	4.00E+01	8.45E-04	4.73E+04	1.60E+00	1.40E-03	2.85E+01	2.85E+01
9	Nickel, soluble & inorg. comp., as Ni	7440-02-0	100	1	5.03E-03	4.00E-02			3.31E+01	2.89E-02	6.90E+01	6.90E+01
10	Nitric Acid	7697-32-2	5,000	50	2.52E-01	2.00E+00	5.18E-03	3.86E+02	3.41E+01	2.98E-02	2.68E+01	2.68E+01
11	Potassium Hydroxide	1310-58-31	2,000	20	1.01E-01	7.99E-01			1.10E+00	9.63E-04	4.15E+01	4.15E+01
11	Silver (metal dust & soluble comp., as Ag)	7440-22-4	100	1	5.04E-03	4.00E-02						
12	Zinc Chloride Fume	7646-85-7	1,000	10	5.04E-02	4.00E-01	5.00E-05	7.99E+03	2.00E-01	1.75E-04	4.57E+01	4.57E+01
13	Toluene-2,4-diisocyanate	584-84-9	20	0.20	1.01E-03	7.99E-03						
14	Tungsten as W insoluble Compounds	7440-33-7	5,000	50	2.52E-01	2.00E+00	6.25E-05	3.20E+04				
CARCINOGENIC POLLUTANTS												
15	Chromic acids & chromate's	1333-82-0	1	0.01	5.03E-05	4.00E-04			1.00E-01	8.75E-05	4.57E+00	4.57E+00
16	Hydrazine	302-01-2	13	0.1	6.54E-04	5.19E-03			2.00E-01	1.75E-04	2.97E+01	2.97E+01
17	Nickel, metal (dust)	7440-02-0	1,000	10	5.03E-02	4.00E-01	6.25E-05	6.39E+03				

TABLE 1 (PART K).—8-Hour SLEVs of Potentially Sensitive Noncarcinogenic Pollutants from Building 35 of TA-3

NO.	TOXIC AIR POLLUTANTS	CAS NUMBER	OELS $\mu\text{g}/\text{m}^3$	1/100 OF THE OELS $\mu\text{g}/\text{m}^3$	8-HOUR SLEVS		RAPS 1990 DATA		ACIS 1995 DATA			THE SMALLER (R ¹) OR (R ²) RATIO
					g/sec	lb/hr	HOURLY EMISSION RATE FROM RAPS (Q ^{hr})	RATIO SLEVS/Q ^{hr} (R ¹)	PURCHASED AMOUNT OF CHEMICALS FROM ACIS	ESTIMATE D HOURLY EMISSION RATES (Q ^{hr})	RATIO SLEVS/Q ^{hr} (R ²)	
1	2	3	4	5	6	7	8	9	10	11	12	13
1	Carbon Black	1333-86-4	3,500	35	1.76E-01	1.40E+00	1.25E-05	1.12E+05				1.12E+05
2	Propane	74-98-6	1,800,000	18,000	9.06E+01	7.19E+02			1.81E+02	1.59E-01	4.53E+03	4.53E+03

TABLE 1 (PART L).—8-Hour SLEVs of Potentially Sensitive Noncarcinogenic Pollutants from Building 35 of TA-3

NO.	TOXIC AIR POLLUTANTS	CAS NUMBER	OELS $\mu\text{g}/\text{m}^3$	1/100 OF THE OELS $\mu\text{g}/\text{m}^3$	8-HOUR SLEVS		RAPS 1990 DATA		ACIS 1995 DATA			THE SMALLER (R ¹) OR (R ²) RATIO
					g/sec	lb/hr	HOURLY EMISSION RATE FROM RAPS (Q ^{hr})	RATIO SLEVS/Q ^{hr} (R ¹)	PURCHASED AMOUNT OF CHEMICALS FROM ACIS	ESTIMATED HOURLY EMISSION RATES (Q ^{hr})	RATIO SLEVS/Q ^{hr} (R ²)	
1	2	3	4	5	6	7	8	9	10	11	12	13
1	Aluminum, Welding Fumes, as Al	7429-90-5	5,000	50	2.52E-01	2.00E+00	9.00E-04	2.22E+03				2.22E+03
2	Hydrogen Chloride	7647-01-0	7,000	70	3.52E-01	2.80E+00	7.75E-04	3.61E+03	7.81E+01	6.83E-02	4.10E+01	4.10E+01
3	Propane	74-98-6	1,800,000	18,000	9.06E+01	7.19E+02			6.44E+02	5.63E-01	1.28E+03	1.28E+03
4	Welding Fumes not otherwise listed	NA	5,000	50	2.52E-01	2.00E+00	1.05E+00	1.91E+00				1.91E+00

TABLE 1 (PART M).—8-Hour SLEVs of Potentially Sensitive Noncarcinogenic and Carcinogenic Pollutants from Building 39 of TA-3

NO.	TOXIC AIR POLLUTANTS	CAS NUMBER	OELS $\mu\text{g}/\text{m}^3$	1/100 OF THE OELS $\mu\text{g}/\text{m}^3$	8-HOUR SLEVS		RAPS 1990 DATA		ACIS 1995 DATA			THE SMALLER (R ¹) OR (R ²) RATIO
					g/sec	lb/hr	HOURLY EMISSION RATE FROM RAPS (Q ^{hr})	RATIO SLEVS/Q ^{hr} (R ¹)	PURCHASED AMOUNT OF CHEMICALS FROM ACIS	ESTIMATED HOURLY EMISSION RATES (Q ^{hr})	RATIO SLEVS/Q ^{hr} (R ²)	
1	2	3	4	5	6	7	8	9	10	11	12	13
NONCARCINOGENIC POLLUTANTS												
2	Aluminum, Welding Fumes, as Al	7429-90-5	5,000	50	2.52E-01	2.00E+00	6.03E-01	3.31E+00				3.31E+00
3	Hydrogen Chloride	7647-01-0	7,000	70	3.52E-01	2.80E+00	1.96E-02	1.43E+02				1.43E+02
4	Kerosene	8008-20-6	100,000	1,000	5.04E+00	4.00E+01	1.05E-03	3.81E+04				3.81E+04
5	Nitric Acid	7697-32-2	5,000	50	2.52E-01	2.00E+00	2.42E-02	8.27E+01				8.27E+01
6	Oil Mist, Mineral	NA	5,000	50	2.52E-01	2.00E+00	1.25E-02	1.60E+02				1.60E+02
7	Propane	74-98-6	1,800,000	18,000	9.06E+01	7.19E+02			3.63E+02	3.18E-01	2.26E+03	2.26E+03
8	Silica, Fused (respirable)	60676-86-0	100	1	5.04E-03	4.00E-02	2.50E-03	1.60E+01				1.60E+01
9	Tungsten as W insoluble Compounds	7440-33-7	5,000	50	2.52E-01	2.00E+00	6.01E-01	3.33E+00				3.33E+00
10	Welding Fumes not otherwise listed	NA	5,000	50	2.52E-01	2.00E+00	8.56E-01	2.33E+00				2.33E+00
11	Zinc Chloride Fume	7646-85-7	1,000	10	5.04E-02	4.00E-01	5.00E-03	7.99E+01				7.99E+01
CARCINOGENIC POLLUTANTS												
1	Nickel, metal (dust)	7440-02-0	1,000	10	5.03E-02	4.00E-01	3.00E-01	1.33E+00				1.33E+00

TABLE 1 (PART N).—8-Hour SLEVs of Potentially Sensitive Noncarcinogenic and Carcinogenic Pollutants from Building 40 of TA-3

NO.	TOXIC AIR POLLUTANTS	CAS NUMBER	OELS $\mu\text{g}/\text{m}^3$	1/100 OF THE OELS $\mu\text{g}/\text{m}^3$	8-HOUR SLEVS		RAPS 1990 DATA		ACIS 1995 DATA			THE SMALLER (R ¹) OR (R ²) RATIO
					g/sec	lb/hr	lb/hr	lb/hr	RATIO SLEVS/Q ^{hr} (R ¹)	PURCHASED AMOUNT OF CHEMICALS FROM ACIS	ESTIMATED HOURLY EMISSION RATES (Q ^{hr})	
									lb/year	lb/hr		
1	2	3	4	5	6	7	8	9	10	11	12	13
NONCARCINOGENIC POLLUTANTS												
1	Aluminum, Metal Dust, as Al	7429-90-5	10,000	100	5.03E-01	4.00E+00	1.25E-02	3.19E+02				3.19E+02
2	Aluminum, Welding Fumes, as Al	7429-90-5	5,000	50	2.52E-01	2.00E+00	2.25E-05	8.88E+04				8.88E+04
3	Carbon Black	1333-86-4	3,500	35	1.76E-01	1.40E+00	2.50E-05	5.59E+04				5.59E+04
4	Hydrogen Chloride	7647-01-0	7,000	70	3.52E-01	2.80E+00	1.52E-03	1.85E+03	2.08E+01	1.82E-02	1.54E+02	1.54E+02
5	Hydrogen Fluoride, as F	7664-39-3	2,300	23	1.16E-01	9.19E-01	8.25E-03	1.11E+02	1.27E+00	1.11E-03	8.29E+02	1.11E+02
6	Hydrogen Peroxide	7722-84-1	1,400	14	7.05E-02	5.59E-01	1.18E-03	4.76E+02	1.71E+01	1.50E-02	3.73E+01	3.73E+01
7	Kerosene	8008-20-6	100,000	1,000	5.04E+00	4.00E+01	8.94E-02	4.47E+02	5.72E+01	5.00E-02	7.99E+02	4.47E+02
8	Nitric Acid	7697-32-2	5,000	50	2.52E-01	2.00E+00	3.59E-02	5.57E+01	2.15E+01	1.88E-02	1.06E+02	5.57E+01
9	Oil Mist, Mineral	NA	5,000	50	2.52E-01	2.00E+00	5.28E-03	3.79E+02				3.79E+02
10	Phosphoric Acid	7664-38-2	1,000	10	5.03E-02	4.00E-01	6.25E-04	6.39E+02				6.39E+02
11	Potassium Hydroxide	1310-58-31	2,000	20	1.01E-01	7.99E-01	1.25E-04	6.39E+03	5.50E+00	4.81E-03	1.66E+02	1.66E+02
12	Propane	74-98-6	1,800,000	18,000	9.06E+01	7.19E+02			1.95E+02	1.71E-01	4.21E+03	4.21E+03
13	Sulfuric Acid	7664-93-9	1,000	10	5.04E-02	4.00E-01	1.26E-02	3.17E+01	1.83E+01	1.60E-02	2.50E+01	2.50E+01
14	Tungsten as W insoluble Compounds	7440-33-7	5,000	50	2.52E-01	2.00E+00	3.63E-05	5.51E+04				5.51E+04
15	Wood Dust (certain hard woods)	NA	1,000	10	5.04E-02	4.00E-01	1.13E-03	3.55E+02				3.55E+02
CARCINOGENIC POLLUTANTS												
16	Nickel, Metal (dust)	7440-02-0	1,000	10	5.03E-02	4.00E-01	1.19E-04	3.36E+03				3.36E+03
17	1,1,2-Trichloroethane	79-00-5	45,000	450	2.27E+00	1.80E+01	3.88E-02	4.64E+02				4.64E+02

TABLE 1 (PART O).—8-Hour SLEVs of Potentially Sensitive Noncarcinogenic Pollutants from Building 43 of TA-3

NO.	TOXIC AIR POLLUTANTS	CAS NUMBER	OELS $\mu\text{g}/\text{m}^3$	1/100 OF THE OELS $\mu\text{g}/\text{m}^3$	8-HOUR SLEVS		RAPS 1990 DATA		ACIS 1995 DATA			THE SMALLER (R ¹) OR (R ²) RATIO
					g/sec	lb/hr	HOURLY EMISSION RATE FROM RAPS (Q ^{hr})	RATIO SLEVS/Q ^{hr} (R ¹)	PURCHASED AMOUNT OF CHEMICALS FROM ACIS	ESTIMATED HOURLY EMISSION RATES (Q ^{hr})	RATIO SLEVS/Q ^{hr} (R ²)	
					lb/hr	lb/hr	lb/hr	lb/year	lb/hr			
1	2	3	4	5	6	7	8	9	10	11	12	13
2	Acetic Acid	64-19-7	25,000	250	1.26E+00	9.99E+00	8.03E-03	1.24E+03				1.24E+03
3	Ammonia	7664-41-7	17,000	170	8.56E-01	6.79E+00	5.55E-01	1.22E+01				1.22E+01
4	Carbon Black	1333-86-4	3,500	35	1.76E-01	1.40E+00	6.95E-03	2.01E+02				2.01E+02
5	Kerosene	8008-20-6	100,000	1,000	5.04E+00	4.00E+01	1.00E-02	4.00E+03				4.00E+03
6	Potassium Hydroxide	1310-58-31	2,000	20	1.01E-01	7.99E-01	3.13E-06	2.56E+05				2.56E+05
7	Wood Dust (certain hard woods)	NA	1,000	10	5.04E-02	4.00E-01	1.25E-03	3.20E+02				3.20E+02
8	1,1,2-Trichloroethane	79-00-5	45,000	450	2.27E+00	1.80E+01	2.50E-02	7.19E+02				7.19E+02

TABLE 1 (PART P).—8-Hour SLEVs of Potentially Sensitive Noncarcinogenic and Carcinogenic Pollutants from Building 66 of TA-3

NO.	TOXIC AIR POLLUTANTS	CAS NUMBER	OELS $\mu\text{g}/\text{m}^3$	1/100 OF THE OELS $\mu\text{g}/\text{m}^3$	8-HOUR SLEVs		RAPS 1990 DATA		ACIS 1995 DATA			THE SMALLER (R ¹) OR (R ²) RATIO
					g/sec	lb/hr	HOURLY EMISSION RATE FROM RAPS (Q ^{hr})	RATIO SLEVs/Q ^{hr} (R ¹)	PURCHASED AMOUNT OF CHEMICALS FROM ACIS	ESTIMATED HOURLY EMISSION RATES (Q ^{lb/hr})	RATIO SLEVs/Q ^{lb/hr} (R ²)	
1	2	3	4	5	6	7	8	9	10	11	12	13
NONCARCINOGENIC POLLUTANTS												
2	Acetic Acid	64-19-7	25,000	250	1.26E+00	9.99E+00	1.38E-03	7.27E+03				7.27E+03
3	Aluminum, Metal Dust, as Al	7429-90-5	10,000	100	5.04E-01	4.00E+00	2.81E-02	1.42E+02				1.42E+02
4	Aluminum, Welding Fumes, as Al	7429-90-5	5,000	50	2.52E-01	2.00E+00	1.50E-04	1.33E+04				1.33E+04
5	Ammonia	7664-41-7	17,000	170	8.56E-01	6.79E+00	5.50E-03	1.24E+03				1.24E+03
6	Carbon Black	1333-86-4	3,500	35	1.76E-01	1.40E+00	5.00E-03	2.80E+02				2.80E+02
7	Hydrogen Chloride	7647-01-0	7,000	70	3.52E-01	2.80E+00	7.12E-04	3.93E+03	1.03E+02	8.99E-02	3.11E+01	3.11E+01
8	Hydrogen Fluoride, as F	7664-39-3	2,300	23	1.16E-01	9.19E-01	1.88E-03	4.90E+02	1.27E+00	1.11E-03	8.29E+02	4.90E+02
9	Hydrogen Peroxide	7722-84-1	1,400	14	7.05E-02	5.59E-01	1.50E-04	3.73E+03				3.73E+03
10	Kerosene	8008-20-6	100,000	1,000	5.04E+00	4.00E+01	2.92E-02	1.37E+03				1.37E+03
11	Nickel, soluble & inorg. comp., as Ni	7440-02-0	100	1	5.03E-03	4.00E-02	7.53E-06	5.31E+03				5.31E+03
12	Nitric Acid	7697-32-2	5,000	50	2.52E-01	2.00E+00	1.05E-02	1.90E+02	1.04E+02	9.12E-02	2.19E+01	2.19E+01
13	Oil Mist, Mineral	NA	5,000	50	2.52E-01	2.00E+00	4.28E-03	4.67E+02				4.67E+02
14	Phosphoric Acid	7664-38-2	1,000	10	5.03E-02	4.00E-01	1.37E-03	2.92E+02				2.92E+02
15	Potassium Hydroxide	1310-58-31	2,000	20	1.01E-01	7.99E-01	3.20E-07	2.50E+06				2.50E+06
16	Propane	74-98-6	1,800,000	18,000	9.06E+01	7.19E+02			5.14E+02	4.49E-01	1.60E+03	1.60E+03
17	Silica, Quartz	14808-60-7	100	1	5.03E-03	4.00E-02	2.50E-04	1.60E+02	2.64E+01	2.31E-02	1.73E+00	1.73E+00
18	Silica, Fused (respirable)	60676-86-0	100	1	5.04E-03	4.00E-02	6.25E-05	6.39E+02				6.39E+02
19	Silver (metal dust & soluble comp., as Ag)	7440-22-4	100	1	5.04E-03	4.00E-02	5.00E-05	7.99E+02				7.99E+02
20	Sulfuric Acid	7664-93-9	1,000	10	5.04E-02	4.00E-01	3.35E-03	1.19E+02	2.03E+00	1.78E-03	2.25E+02	1.19E+02

TABLE 1 (PART P).—8-Hour SLEVs of Potentially Sensitive Noncarcinogenic and Carcinogenic Pollutants from Building 66 of TA-3-

NO.	TOXIC AIR POLLUTANTS	CAS NUMBER	OELS $\mu\text{g}/\text{m}^3$	1/100 OF THE OELS $\mu\text{g}/\text{m}^3$	8-HOUR SLEVS		RAPS 1990 DATA		ACIS 1995 DATA			THE SMALLER (R ¹) OR (R ²) RATIO
					g/sec	lb/hr	HOURLY EMISSION RATE FROM RAPS (Q ^{hr})	RATIO SLEVS/Q ^{hr} (R ¹)	PURCHASED AMOUNT OF CHEMICALS FROM ACIS	ESTIMATED HOURLY EMISSION RATES (Q ^{lb/hr})	RATIO SLEVS/Q ^{lb/hr} (R ²)	
1	2	3	4	5	6	7	8	9	10	11	12	13
21	Tungsten as W insoluble Compounds	7440-33-7	5,000	50	2.52E-01	2.00E+00	1.50E-04	1.33E+04				1.33E+04
22	Welding Fumes not otherwise listed	NA	5,000	50	2.52E-01	2.00E+00	3.13E-02	6.38E+01				6.38E+01
CARCINOGENIC POLLUTANTS												
23	Chromic acids & chromates	1333-82-0	1.00	0.01	5.03E-05	4.00E-04	1.25E-04	3.20E+00				3.20E+00
24	1,1,2-Trichloroethane	79-00-5	45,000	450	2.27E+00	1.80E+01	4.15E-03	4.33E+03				4.33E+03

TABLE 1 (PART Q).—8-Hour SLEVs of Potentially Sensitive Noncarcinogenic Pollutants from Building 70 of TA-3

NO.	TOXIC AIR POLLUTANTS	CAS NUMBER	OELS $\mu\text{g}/\text{m}^3$	1/100 OF THE OELS $\mu\text{g}/\text{m}^3$	8-HOUR SLEVS		RAPS 1990 DATA		ACIS 1995 DATA			THE SMALLER (R ¹) OR (R ²) RATIO
					g/sec	lb/hr	HOURLY EMISSION RATE FROM RAPS (Q ^{hr})	lb/hr	RATIO SLEVS/Q ^{hr} (R ¹)	PURCHASED AMOUNT OF CHEMICALS FROM ACIS	ESTIMATED HOURLY EMISSION RATES (Q ^{hr})	
1	2	3	4	5	6	7	8	9	10	11	12	13
1	Propane	74-98-6	1,800,000	18,000	9.06E+01	7.19E+02			2.51E+03	2.19E+00	3.28E+02	3.28E+02

TABLE 1 (PART R).—8-Hour SLEVs of Potentially Sensitive Noncarcinogenic Pollutants from Building 142 of TA-3

NO.	TOXIC AIR POLLUTANTS	CAS NUMBER	OELS $\mu\text{g}/\text{m}^3$	1/100 OF THE OELS $\mu\text{g}/\text{m}^3$	8-HOUR SLEVS		RAPS 1990 DATA		ACIS 1995 DATA			THE SMALLER (R ¹) OR (R ²) RATIO
					g/sec	lb/hr	HOURLY EMISSION RATE FROM RAPS (Q ^{hr})	lb/hr	RATIO SLEVS/Q ^{hr} (R ¹)	PURCHASED AMOUNT OF CHEMICALS FROM ACIS	ESTIMATED HOURLY EMISSION RATES (Q ^{hr})	
1	2	3	4	5	6	7	8	9	10	11	12	13
1	Propane	74-98-6	1,800,000	18,000	9.06E+01	7.19E+02			1.09E+03	9.53E-01	7.55E+02	7.55E+02

TABLE 1 (PART S).—8-Hour SLEVs of Potentially Sensitive Noncarcinogenic Pollutants from Building 102 of TA-3

NO.	TOXIC AIR POLLUTANTS	CAS NUMBER	OELS $\mu\text{g}/\text{m}^3$	1/100 OF THE OELS $\mu\text{g}/\text{m}^3$	8-HOUR SLEVs		RAPS 1990 DATA		ACIS 1995 DATA			THE SMALLER (R ¹) OR (R ²) RATIO
					g/sec	lb/hr	g/sec	lb/hr	HOURLY EMISSION RATE FROM RAPS (Q ^{hr})	RATIO SLEVs/Q ^{hr} (R ¹)	PURCHASED AMOUNT OF CHEMICALS FROM ACIS	
1	2	3	4	5	6	7	8	9	10	11	12	13
1	Lithium Hydride	7580-67-8	25	0.25	1.26E-03	9.99E-03	1.02E-02	9.82E-01				9.82E-01

TABLE 1 (PART T).—8-Hour SLEVs of Potentially Sensitive Noncarcinogenic Pollutants from Building 102 of TA-3

NO.	TOXIC AIR POLLUTANTS	CAS NUMBER	OELS $\mu\text{g}/\text{m}^3$	1/100 OF THE OELS $\mu\text{g}/\text{m}^3$	8-HOUR		RAPS 1990 DATA		ACIS 1995 DATA			THE SMALLER (R ¹) OR (R ²) RATIO
					g/sec	lb/hr	g/sec	lb/hr	HOURLY EMISSION RATE FROM RAPS (Q ^{hr})	RATIO SLEVs/Q ^{hr} (R ¹)	PURCHASED AMOUNT OF CHEMICALS FROM ACIS	
1	2	3	4	5	6	7	8	9	10	11	12	13
1	Hydrogen Chloride	7647-01-0	7,000	70	3.52E-01	2.80E+00	5.00E-04	5.59E+03				5.59E+03
2	Nitric Acid	7697-32-2	5,000	50	2.52E-01	2.00E+00	2.80E-02	7.14E+01				7.14E+01
3	Sulfuric Acid	7664-93-9	1,000	10	5.04E-02	4.00E-01	2.50E-04	1.60E+03				1.60E+03
4	Welding Fumes not otherwise listed	NA	5,000	50	2.52E-01	2.00E+00	2.06E-03	9.70E+02				9.70E+02

TABLE 1 (PART U).—8-Hour SLEVs of Potentially Sensitive Noncarcinogenic Pollutants from Building 132 of TA-3

NO.	TOXIC AIR POLLUTANTS	CAS NUMBER	OELS $\mu\text{g}/\text{m}^3$	1/100 OF THE OELS $\mu\text{g}/\text{m}^3$	8-HOUR SLEVS		RAPS 1990 DATA		ACIS 1995 DATA			THE SMALLER (R ¹) OR (R ²) RATIO
					g/sec	lb/hr	lb/hr	lb/hr	HOURLY EMISSION RATE FROM RAPS (Q ^{hr})	RATIO SLEVS/Q ^{hr} (R ¹)	PURCHASED AMOUNT OF CHEMICALS FROM ACIS	
1	2	3	4	5	6	7	8	9	10	11	12	13
1	Acetic Acid	64-19-7	25,000	250	1.26E+00	9.99E+00	2.79E+00	3.58E+00				3.58E+00

TABLE 1 (PART V).—8-Hour SLEVs of Potentially Sensitive Noncarcinogenic and Carcinogenic Pollutants from Building 141 of TA-3

NO.	TOXIC AIR POLLUTANTS	CAS NUMBER	OELS $\mu\text{g}/\text{m}^3$	1/100 OF THE OELS $\mu\text{g}/\text{m}^3$	8-HOUR SLEVS		RAPS 1990 DATA		ACIS 1995 DATA			THE SMALLER (R ¹) OR (R ²) RATIO
					g/sec	lb/hr	lb/hr	lb/hr	HOURLY EMISSION RATE FROM RAPS (Q ^{hr})	RATIO SLEVS/Q ^{hr} (R ¹)	PURCHASED AMOUNT OF CHEMICALS FROM ACIS	
NONCARCINOGENIC POLLUTANTS												
1	Carbon Black	1333-86-4	3,500	35	1.76E-01	1.40E+00	2.50E-03	5.59E+02				5.59E+02
2	Nitric Acid	7697-32-2	5,000	50	2.52E-01	2.00E+00	7.50E-04	2.66E+03				2.66E+03
3	Tungsten as W insoluble Compounds	7440-33-7	5,000	50	2.52E-01	2.00E+00	1.25E-03	1.60E+03				1.60E+03
CARCINOGENIC POLLUTANTS												
4	Nickel, soluble & inorg. comp., as Ni	7440-02-0	100	1	5.03E-03	4.00E-02	1.25E-04	3.20E+02				3.20E+02

TABLE 1 (PART W).—8-Hour SLEVs of Potentially Sensitive Noncarcinogenic Pollutants from Building 170 of TA-3

NO.	TOXIC AIR POLLUTANTS	CAS NUMBER	OELS $\mu\text{g}/\text{m}^3$	1/100 OF THE OELS $\mu\text{g}/\text{m}^3$	8-HOUR SLEVS		RAPS 1990 DATA		ACIS 1995 DATA			THE SMALLER (R ¹) OR (R ²) RATIO	
					g/sec	lb/hr	lb/hr	HOURLY EMISSION RATE FROM RAPS (Q ^{hr})	RATIO SLEVS/Q ^{hr} (R ¹)	PURCHASED AMOUNT OF CHEMICALS FROM ACIS	ESTIMATED HOURLY EMISSION RATES (Q ^{hr})		RATIO SLEVS/Q ^{hr} (R ²)
1	2	3	4	5	6	7	8	9	10	11	12	13	
1	Propane	74-98-6	1,800,000	18,000	9.06E+01	7.19E+02			4.49E+03	3.93E+00	1.83E+02	1.83E+02	

TABLE 1 (PART X).—8-Hour SLEVs of Potentially Sensitive Noncarcinogenic and Carcinogenic Pollutants from Building 223 of TA-3

NO.	TOXIC AIR POLLUTANTS	CAS NUMBER	OELS $\mu\text{g}/\text{m}^3$	1/100 OF THE OELS $\mu\text{g}/\text{m}^3$	8-HOUR SLEVS		RAPS 1990 DATA		ACIS 1995 DATA			THE SMALLER (R ¹) OR (R ²) RATIO	
					g/sec	lb/hr	lb/hr	HOURLY EMISSION RATE FROM RAPS (Q ^{hr})	RATIO SLEVS/Q ^{hr} (R ¹)	PURCHASED AMOUNT OF CHEMICALS FROM ACIS	ESTIMATED HOURLY EMISSION RATES (Q ^{hr})		RATIO SLEVS/Q ^{hr} (R ²)
1	2	3	4	5	6	7	8	9	10	11	12	13	
NONCARCINOGENIC POLLUTANTS													
1	2-Butoxyethanol	111-76-2	121,000	1,210	6.09E+00	4.84E+01	5.01E-01	9.66E+01				9.66E+01	
2	Kerosene	8008-20-6	100,000	1,000	5.04E+00	4.00E+01	8.36E-01	4.78E+01				4.78E+01	
3	Sulfuric Acid	7664-93-9	1,000	10	5.04E-02	4.00E-01			8.11E-01	7.10E-04	5.63E+02	5.63E+02	
CARCINOGENIC POLLUTANTS													
4	1,1,2-Trichloroethane	79-00-5	45,000	450	2.27E+00	1.80E+01	3.03E+00	5.94E+00				5.94E+00	

TABLE 1 (PART Y).—8-Hour SLEVs of Potentially Sensitive Noncarcinogenic Pollutants from Building 287 of TA-3

NO.	TOXIC AIR POLLUTANTS	CAS NUMBER	OELS $\mu\text{g}/\text{m}^3$	1/100 OF THE OELS $\mu\text{g}/\text{m}^3$	8-HOUR SLEVS		RAPS 1990 DATA		ACIS 1995 DATA			THE SMALLER (R ¹) OR (R ²) RATIO
					g/sec	lb/hr	HOURLY EMISSION RATE FROM RAPS (Q ^{hr})	RATIO SLEVS/Q ^{hr} (R ¹)	PURCHASED AMOUNT OF CHEMICALS FROM ACIS	ESTIMATED HOURLY EMISSION RATES (Q ^{hr})	RATIO SLEVS/Q ^{hr} (R ²)	
1	2	3	4	5	6	7	8	9	10	11	12	13
1	Aluminum, Metal Dust, as Al	7429-90-5	10,000	100	5.04E-01	4.00E+00	2.50E-04	1.60E+04				1.60E+04
2	Kerosene	8008-20-6	100,000	1,000	5.04E+00	4.00E+01	3.00E-03	1.33E+04				1.33E+04

TABLE 1 (PART Z).—8-Hour SLEVs of Potentially Sensitive Noncarcinogenic Pollutants from Building 316 of TA-3

NO.	TOXIC AIR POLLUTANTS	CAS NUMBER	OELS $\mu\text{g}/\text{m}^3$	1/100 OF THE OELS $\mu\text{g}/\text{m}^3$	8-HOUR SLEVS		RAPS 1990 DATA		ACIS 1995 DATA			THE SMALLER (R ¹) OR (R ²) RATIO
					g/sec	lb/hr	HOURLY EMISSION RATE FROM RAPS (Q ^{hr})	RATIO SLEVS/Q ^{hr} (R ¹)	PURCHASED AMOUNT OF CHEMICALS FROM ACIS	ESTIMATED HOURLY EMISSION RATES (Q ^{hr})	RATIO SLEVS/Q ^{hr} (R ²)	
1	2	3	4	5	6	7	8	9	10	11	12	13
1	Propane	74-98-6	1,800,000	18,000	9.06E+01	7.19E+02			1.21E+02	1.06E-01	6.79E+03	6.79E+03

TABLE 1 (PART AA).—8-Hour SLEVs of Potentially Sensitive Noncarcinogenic Pollutants from Building 409 of TA-3

NO.	TOXIC AIR POLLUTANTS	CAS NUMBER	OELS $\mu\text{g}/\text{m}^3$	1/100 OF THE OELS $\mu\text{g}/\text{m}^3$	8-HOUR SLEVS		RAPS 1990 DATA		ACIS 1995 DATA			THE SMALLER (R ¹) OR (R ²) RATIO
					g/sec	lb/hr	HOURLY EMISSION RATE FROM RAPS (Q ^{hr})	RATIO SLEVS/Q ^{hr} (R ¹)	PURCHASED AMOUNT OF CHEMICALS FROM ACIS	ESTIMATED HOURLY EMISSION RATES (Q ^{hb})	RATIO SLEVS/Q ^{hb} (R ²)	
1	2	3	4	5	6	7	8	9	10	11	12	13
1	Acetic Acid	64-19-7	25,000	250	1.26E+00	9.99E+00	1.17E-02	8.51E+02				8.51E+02

TABLE 1 (PART BB).—8-Hour SLEVs of Potentially Sensitive Noncarcinogenic Pollutants from Building 425 of TA-3

NO.	TOXIC AIR POLLUTANTS	CAS NUMBER	OELS $\mu\text{g}/\text{m}^3$	1/100 OF THE OELS $\mu\text{g}/\text{m}^3$	8-HOUR SLEVS		RAPS 1990 DATA		ACIS 1995 DATA			THE SMALLER (R ¹) OR (R ²) RATIO
					g/sec	lb/hr	HOURLY EMISSION RATE FROM RAPS (Q ^{hr})	RATIO SLEVS/Q ^{hr} (R ¹)	PURCHASED AMOUNT OF CHEMICALS FROM ACIS	ESTIMATED HOURLY EMISSION RATES (Q ^{hb})	RATIO SLEVS/Q ^{hb} (R ²)	
1	2	3	4	5	6	7	8	9	10	11	12	13
1	Propane	74-98-6	1,800,000	18,000	9.06E+01	7.19E+02			3.86E+01	3.37E-02	2.13E+04	2.13E+04

TABLE 1 (PART CC).—8-Hour SLEVs of Potentially Sensitive Noncarcinogenic Pollutants from Building 494 of TA-3

NO.	TOXIC AIR POLLUTANTS	CAS NUMBER	OELS $\mu\text{g}/\text{m}^3$	1/100 OF THE OELS $\mu\text{g}/\text{m}^3$	8-HOUR SLEVS		RAPS 1990 DATA		ACIS 1995 DATA			THE SMALLER (R^1) OR (R^2) RATIO
					g/sec	lb/hr	HOURLY EMISSION RATE FROM RAPS (Q^{hr})	RATIO SLEVS/ Q^{hr} (R^1)	PURCHASED AMOUNT OF CHEMICALS FROM ACIS	ESTIMATED HOURLY EMISSION RATES (Q^{hr})	RATIO SLEVS/ Q^{hr} (R^2)	
		3	4	5	6	7	8	9	10	11	12	13
1	Acetic Acid	64-19-7	25,000	250	1.26E+00	9.99E+00	1.06E-05	9.40E+05				9.40E+05
2	Aluminum, Metal Dust, as Al	7429-90-5	10,000	100	5.04E-01	4.00E+00	2.50E-06	1.60E+06				1.60E+06
3	Ammonia	7664-41-7	17,000	170	8.56E-01	6.79E+00	1.25E-04	5.43E+04				5.43E+04
4	Hydrogen Chloride	7647-01-0	7,000	70	3.52E-01	2.80E+00	4.63E-05	6.05E+04	4.29E+01	3.76E-02	7.45E+01	7.45E+01
5	Hydrogen Fluoride, as F	7664-39-3	2,300	23	1.16E-01	9.19E-01	1.00E-04	9.19E+03	7.61E+00	6.66E-03	1.38E+02	1.38E+02
6	Hydrogen Peroxide	7722-84-1	1,400	14	7.05E-02	5.59E-01	3.75E-06	1.49E+05				1.49E+05
7	Nickel, soluble & inorg. comp., as Ni	7440-02-0	100	1	5.03E-03	4.00E-02	1.25E-10	3.20E+08				3.20E+08
8	Nitric Acid	7697-32-2	5,000	50	2.52E-01	2.00E+00	1.75E-04	1.14E+04	5.46E+01	4.78E-02	4.18E+01	4.18E+01
9	Phosphoric Acid	7664-38-2	1,000	10	5.03E-02	4.00E-01	5.00E-07	7.99E+05	4.04E+00	3.53E-03	1.13E+02	1.13E+02
10	Potassium Hydroxide	1310-58-31	2,000	20	1.01E-01	7.99E-01	1.25E-06	6.39E+05				6.39E+05
11	Silver (metal dust & soluble comp., as Ag)	7440-22-4	100	1	5.04E-03	4.00E-02	5.00E-12	7.99E+09				7.99E+09
12	Sulfuric Acid	7664-93-9	1,000	10	5.04E-02	4.00E-01	9.50E-06	4.21E+04				4.21E+04
13	Tungsten as W insoluble Compounds	7440-33-7	5,000	50	2.52E-01	2.00E+00	5.00E-10	4.00E+09				4.00E+09

TABLE 1 (PART DD).—8-Hour SLEVs of Potentially Sensitive Noncarcinogenic Pollutants from Building 495 of TA-3

NO.	TOXIC AIR POLLUTANTS	CAS NUMBER	OELS $\mu\text{g}/\text{m}^3$	1/100 OF THE OELS $\mu\text{g}/\text{m}^3$	8-HOUR SLEVS		RAPS 1990 DATA		ACIS 1995 DATA			THE SMALLER (R ¹) OR (R ²) RATIO
					g/sec	lb/hr	HOURLY EMISSION RATE FROM RAPS (Q ^{hr})	RATIO SLEVS/Q ^{hr} (R ¹)	PURCHASED AMOUNT OF CHEMICALS FROM ACIS	ESTIMATED HOURLY EMISSION RATES (Q ^{ha})	RATIO SLEVS/Q ^{ha} (R ²)	
1	2	3	4	5	6	7	8	9	10	11	12	13
1	Silver (metal dust & soluble comp., as Ag)	7440-22-4	100	1	5.04E-03	4.00E-02	9.50E-07	4.21E+04				4.21E+04

TABLE 1 (PART EE).—8-Hour SLEVs of Potentially Sensitive Noncarcinogenic Pollutants from Building 502 of TA-3

NO.	TOXIC AIR POLLUTANTS	CAS NUMBER	OELS $\mu\text{g}/\text{m}^3$	1/100 OF THE OELS $\mu\text{g}/\text{m}^3$	8-HOUR SLEVS		RAPS 1990 DATA		ACIS 1995 DATA			THE SMALLER (R ¹) OR (R ²) RATIO
					g/sec	lb/hr	HOURLY EMISSION RATE FROM RAPS (Q ^{hr})	RATIO SLEVS/Q ^{hr} (R ¹)	PURCHASED AMOUNT OF CHEMICALS FROM ACIS	ESTIMATED HOURLY EMISSION RATES (Q ^{ha})	RATIO SLEVS/Q ^{ha} (R ²)	
1	2	3	4	5	6	7	8	9	10	11	12	13
1	Propane	74-98-6	1,800,000	18,000	9.06E+01	7.19E+02			1.21E+02	1.06E-01	6.79E+03	6.79E+03

TABLE 1 (PART FF).—8-Hour SLEVs of Potentially Sensitive Noncarcinogenic Pollutants from Building 562 of TA-3

NO.	TOXIC AIR POLLUTANTS	CAS NUMBER	OELS $\mu\text{g}/\text{m}^3$	1/100 OF THE OELS $\mu\text{g}/\text{m}^3$	8-HOUR SLEVS		RAPS 1990 DATA		ACIS 1995 DATA			THE SMALLER (R ¹) OR (R ²) RATIO
					g/sec	lb/hr	HOURLY EMISSION RATE FROM RAPS (Q ^{hr})	RATIO SLEVS/Q ^{hr} (R ¹)	PURCHASED AMOUNT OF CHEMICALS FROM ACIS	ESTIMATED HOURLY EMISSION RATES (Q ^{hr})	RATIO SLEVS/Q ^{hr} (R ²)	
1	2	3	4	5	6	7	8	9	10	11	12	13
1	Hydrogen Chloride	7647-01-0	7,000	70	3.52E-01	2.80E+00			3.90E+01	3.41E-02	8.19E+01	8.19E+01

TABLE 1 (PART GG).—8-Hour SLEVs of Potentially Sensitive Noncarcinogenic Pollutants from Building 43/510 of TA-3

NO.	TOXIC AIR POLLUTANTS	CAS NUMBER	OELS $\mu\text{g}/\text{m}^3$	1/100 OF THE OELS $\mu\text{G}/\text{M}^3$	8-HOUR SLEVS		RAPS 1990 DATA		ACIS 1995 DATA			THE SMALLER (R ¹) OR (R ²) RATIO
					g/sec	lb/hr	HOURLY EMISSION RATE FROM RAPS (Q ^{hr})	RATIO SLEVS/Q ^{hr} (R ¹)	PURCHASED AMOUNT OF CHEMICALS FROM ACIS	ESTIMATED HOURLY EMISSION RATES (Q ^{hr})	RATIO SLEVS/Q ^{hr} (R ²)	
1	2	3	4	5	6	7	8	9	10	11	12	13
1	Acetic Acid	64-19-7	25,000	250	1.26E+00	9.99E+00	2.97E-02	3.37E+02				3.37E+02
2	Ammonia	7664-41-7	17,000	170	8.56E-01	6.79E+00	2.07E-02	3.28E+02				3.28E+02

TABLE 1 (PART HH).—8-Hour SLEVs of Potentially Sensitive Noncarcinogenic Pollutants from Building 1498 of TA-3

NO.	TOXIC AIR POLLUTANTS	CAS NUMBER	OELS $\mu\text{g}/\text{m}^3$	1/100 OF THE OELS $\mu\text{g}/\text{m}^3$	8-HOUR SLEVS		RAPS 1990 DATA		ACIS 1995 DATA			THE SMALLER (R ¹) OR (R ²) RATIO
					g/sec	lb/hr	HOURLY EMISSION RATE FROM RAPS (Q ^{hr})	RATIO SLEVS/Q ^{hr} (R ¹)	PURCHASED AMOUNT OF CHEMICALS FROM ACIS	ESTIMATED HOURLY EMISSION RATES (Q ^{hr})	RATIO SLEVS/Q ^{hr} (R ²)	
1	2	3	4	5	6	7	8	9	10	11	12	13
1	Propane	74-98-6	1,800,000	18,000	9.06E+01	7.19E+02			6.05E+01	5.30E-02	1.36E+04	1.36E+04

TABLE 1 (PART II).—8-Hour SLEVs of Potentially Sensitive Noncarcinogenic Pollutants from Building 1559 of TA-3

NO.	TOXIC AIR POLLUTANTS	CAS NUMBER	OELS $\mu\text{g}/\text{m}^3$	1/100 OF THE OELS $\mu\text{g}/\text{m}^3$	8-HOUR SLEVS		RAPS 1990 DATA		ACIS 1995 DATA			THE SMALLER (R ¹) OR (R ²) RATIO
					g/sec	lb/hr	HOURLY EMISSION RATE FROM RAPS (Q ^{hr})	RATIO SLEVS/Q ^{hr} (R ¹)	PURCHASED AMOUNT OF CHEMICALS FROM ACIS	ESTIMATED HOURLY EMISSION RATES (Q ^{hr})	RATIO SLEVS/Q ^{hr} (R ²)	
1	2	3	4	5	6	7	8	9	10	11	12	13
1	Ammonia	7664-41-7	17,000	170	8.56E-01	6.79E+00	1.25E-01	5.43E+01				5.43E+01

TABLE 1 (PART JJ).—8-Hour SLEVs of Potentially Sensitive Noncarcinogenic Pollutants from Building 1698 of TA-3

NO.	TOXIC AIR POLLUTANTS	CAS NUMBER	OELS $\mu\text{g}/\text{m}^3$	1/100 OF THE OELS $\mu\text{g}/\text{m}^3$	8-HOUR SLEVS		RAPS 1990 DATA		ACIS 1995 DATA			THE SMALLER (R ¹) OR (R ²) RATIO
					g/sec	lb/hr	HOURLY EMISSION RATE FROM RAPS (Q ^{hr})	RATIO SLEVS/Q ^{hr} (R ¹)	PURCHASED AMOUNT OF CHEMICALS FROM ACIS	ESTIMATED HOURLY EMISSION RATES (Q ^{hr})	RATIO SLEVS/Q ^{hr} (R ²)	
1	2	3	4	5	6	7	8	9	10	11	12	13
1	Hydrogen Peroxide	7722-84-1	1,400	14	7.05E-02	5.59E-01			2.45E+00	2.14E-03	2.61E+02	2.61E+02
2	Nickel, soluble & inorg. comp., as Ni	7440-02-0	100	1	5.03E-03	4.00E-02			1.00E-01	8.75E-05	4.57E+02	4.57E+02
3	Nitric Acid	7697-32-2	5,000	50	2.52E-01	2.00E+00			1.65E+01	1.45E-02	1.38E+02	1.38E+02
4	Vanadium, Respirable Dust & Fume	1314-62-1	50	1	2.52E-03	2.00E-02			1.10E+00	9.63E-04	2.08E+01	2.08E+01
5	Zinc Chloride Fume	7646-85-7	1,000	10	5.04E-02	4.00E-01			6.00E-01	5.25E-04	7.61E+02	7.61E+02

TABLE 1 (PART KK).—8-Hour SLEVs of Potentially Sensitive Noncarcinogenic Pollutants from Building 1701 of TA-3

NO.	TOXIC AIR POLLUTANTS	CAS NUMBER	OELS $\mu\text{g}/\text{m}^3$	1/100 OF THE OELS $\mu\text{g}/\text{m}^3$	8-HOUR SLEVS		RAPS 1990 DATA			ACIS 1995 DATA			THE SMALLER (R ¹) OR (R ²) RATIO
					g/sec	lb/hr	HOURLY EMISSION RATE FROM RAPS (Q ^{hr})	RATIO SLEVS/Q ^{hr} (R ¹)	PURCHASED AMOUNT OF CHEMICALS FROM ACIS	ESTIMATED HOURLY EMISSION RATES (Q ^{hr})	RATIO SLEVS/Q ^{hr} (R ²)		
1	2	3	4	5	6	7	8	9	10	11	12	13	
1	Wood Dust (certain hard woods)	NA	1,000	10	5.04E-02	4.00E-01	2.50E-03	1.60E+02				1.60E+02	

TABLE 1 (PART LL).—8-Hour SLEVs of Potentially Sensitive Noncarcinogenic Pollutants from Building 2202 of TA-3

NO.	TOXIC AIR POLLUTANTS	CAS NUMBER	OELS $\mu\text{g}/\text{m}^3$	1/100 OF THE OELS $\mu\text{g}/\text{m}^3$	8-HOUR SLEVs		RAPS 1990 DATA		ACIS 1995 DATA			THE SMALLER (R ¹) OR (R ²) RATIO
					g/sec	lb/hr	HOURLY EMISSION RATE FROM RAPS (Q ^{hr})	RATIO SLEVs/Q ^{hr} (R ¹)	PURCHASED AMOUNT OF CHEMICALS FROM ACIS	ESTIMATED HOURLY EMISSION RATES (Q ^{hr})	RATIO SLEVs/Q ^{hr} (R ²)	
1	2	3	4	5	6	7	8	9	10	11	12	13
1	Nitric Acid	7697-32-2	5,000	50	2.52E-01	2.00E+00			1.32E+01	1.16E-02	1.73E+02	1.73E+02
2	Phosphoric Acid	7664-38-2	1,000	10	5.03E-02	4.00E-01			4.04E+00	3.53E-03	1.13E+02	1.13E+02

TABLE 1 (PART MM).—8-Hour SLEVs of Potentially Sensitive Noncarcinogenic Pollutants from Building 2203 of TA-3

NO.	TOXIC AIR POLLUTANTS	CAS NUMBER	OELS $\mu\text{g}/\text{m}^3$	1/100 OF THE OELS $\mu\text{g}/\text{m}^3$	8-HOUR SLEVs		RAPS 1990 DATA		ACIS 1995 DATA			THE SMALLER (R ¹) OR (R ²) RATIO
					g/sec	lb/hr	HOURLY EMISSION RATE FROM RAPS (Q ^{hr})	RATIO SLEVs/Q ^{hr} (R ¹)	PURCHASED AMOUNT OF CHEMICALS FROM ACIS	ESTIMATED HOURLY EMISSION RATES (Q ^{hr})	RATIO SLEVs/Q ^{hr} (R ²)	
1	2	3	4	5	6	7	8	9	10	11	12	13
1	Aluminum, Metal Dust, as Al	7429-90-5	10,000	100	5.04E-01	4.00E+00			1.10E+00	9.63E-04	4.15E+03	4.15E+03
2	Carbon Black	1333-86-4	3,500	35	1.76E-01	1.40E+00			1.10E+00	9.63E-04	1.45E+03	1.45E+03

TABLE 1 (PART NN).—8-Hour SLEVs of Potentially Sensitive Noncarcinogenic Pollutants from Building 2010 of TA-3

NO.	TOXIC AIR POLLUTANTS	CAS NUMBER	OELS $\mu\text{g}/\text{m}^3$	1/100 OF THE OELS $\mu\text{g}/\text{m}^3$	8-HOUR SLEVS		RAPS 1990 DATA		ACIS 1995 DATA			THE SMALLER (R^1) OR (R^2) RATIO
					g/sec	lb/hr	lb/hr	lb/hr	HOURLY EMISSION RATE FROM RAPS (Q^{hr})	RATIO SLEVS/ Q^{hr} (R^1)	PURCHASED AMOUNT OF CHEMICALS FROM ACIS	
1	2	3	4	5	6	7	8	9	10	11	12	13
1	Hydrogen Peroxide	7722-84-1	1,400	14	7.05E-02	5.59E-01			1.47E+01	1.28E-02	4.35E+01	4.35E+01

TABLE 2 (PART A).—Annual SLEVs of the Carcinogenic Pollutants from TA-3 Facilities

NO.	CARCINOGENIC POLLUTANTS	CAS NUMBER	CAR. CLASS	UNIT RISK FACTOR (URF)	MAXIMUM CANCER RISK (C _{an} X URF)	ANNUAL SLEVS		RAPS 1990 DATA		NEW EMISSION RATE DATA			THE SMALLER (R ¹) OR (R ²) RATIO
						g/sec	lb/yr	ANNUAL EMISSION RATE FROM RAPS (Q _{air})	RATIO SLEVS/Q _{air} (R ¹)	PURCHASED AMOUNT OF CHEMICALS FROM ACIS	ESTIMATED ANNUAL EMISSION RATES (Q ^{air})	RATIO SLEVS/Q ^{air} (R ²)	
				(µg/m ³) ⁻¹		lb/yr	lb/yr	lb/yr	lb/yr	lb/year	lb/hr		
1	2	3	4	5	6	7	8	9	10	11	12	13	14
1	Acetaldehyde	75-07-0	B2	2.20E-06	5.42E-06	1.84E-03	2.93E+01			4.00E-01	1.40E-01	2.09E-02	2.09E+02
2	Acrylamide	79-06-1	B2	1.30E-03	3.20E-03	3.12E-06	4.95E-02						
3	Acrylonitrile	107-13-1	B1	6.80E-05	1.68E-04	5.97E-05	9.47E-01						
4	Allyl Chloride	107-05-1	C	5.50E-08	1.36E-07	7.37E-02	1.17E+03						
5	Aldrin	309-00-2	B2	4.90E-03	1.21E-02	8.28E-07	1.31E-02						
6	Arsenic, el. & in., exc. Arsenic, as As	7440-38-2	A	4.30E-03	1.06E-02	9.43E-07	1.50E-02	2.00E-07	7.49E+04				7.49E+04
7	Asbestos	1332-21-4	A	6.90E+00	1.70E+01	5.88E-10	9.33E-06						
8	Benzene	71-43-2	A	8.30E-06	2.05E-05	4.89E-04	7.76E+00				2.37E+00	3.27E+00	3.27E+00
9	Benzidine	92-87-5	A	6.70E-02	1.65E-01	6.05E-08	9.61E-04						
10	Benzo(a)pyrene	50-32-8	B2	1.70E-03	4.19E-03	2.39E-06	3.79E-02						
11	Benzyl Chloride	100-44-7	B2	1.20E-05	2.96E-05	3.38E-04	5.37E+00						
12	Beryllium	7440-41-7	B2	2.40E-03	5.92E-03	1.69E-06	2.68E-02				1.10E-01	2.44E-01	2.44E-01
13	Bis (Chloromethyl) Ether (BCME)	542-88-1	A	6.20E-02	1.53E-01	6.54E-08	1.04E-03						
14	Bromoform	75-25-2	B2	1.10E-06	2.71E-06	3.69E-03	5.85E+01						
15	1,3-Butadiene	106-99-0	B2	2.80E-04	6.90E-04	1.45E-05	2.30E-01						
16	Cadmium, el.&comp., as Cd	7440-43-9	B1	1.80E-03	4.44E-03	2.25E-06	3.58E-02						
17	Carbon Tetrachloride	56-23-5	B2	1.50E-05	3.70E-05	2.70E-04	4.29E+00	5.00E-01	8.58E+00	1.41E+01	4.94E+00	8.70E-01	8.70E-01
18	Chloroform	67-66-3	B2	2.30E-05	5.67E-05	1.76E-04	2.80E+00	4.50E-01	6.22E+00		4.52E+00	6.19E-01	6.19E-01
19	Chlordane	57-74-9	B2	3.70E-04	9.12E-04	1.10E-05	1.74E-01						
20	Chromium VI	18540-29-9	A	1.20E-02	2.96E-02	3.38E-07	5.37E-03						
21	Diethanolamine	111-42-2	--	1.10E-07	2.71E-07	3.69E-02	5.85E+02						
22	3,3-Dichlorobenzidine	91-94-1	B2	4.80E-04	1.18E-03	8.45E-06	1.34E-01						
23	Epichlorohydrin	106-89-8	B2	1.20E-06	2.96E-06	3.38E-03	5.37E+01						
24	Ethyl Acrylate	140-88-5	B2	5.00E-07	1.23E-06	8.11E-03	1.29E+02			6.09E-01	2.13E-01	6.05E+02	6.05E+02

TABLE 2 (PART A).—Annual SLEVs of the Carcinogenic Pollutants from TA-3 Facilities-Continued

NO.	CARCINOGENIC POLLUTANTS	CAS NUMBER	CAR. CLASS	UNITRISK FACTOR (URF) ($\mu\text{g}/\text{m}^3\text{-yr}^{-1}$)	MAXIMUM CANCER RISK (Can. X URF)	ANNUAL SLEVS		RAPS 1990 DATA		NEW EMISSION RATE DATA			THE SMALLER (R ¹) OR (R ²) RATIO
						g/sec	lb/yr	ANNUAL EMISSION RATE FROM RAPS (Q ^{AR})	RATIO SLEVS/Q ^{AR} (R ¹)	PURCHASED AMOUNT OF CHEMICALS FROM ACTS	ESTIMATED ANNUAL EMISSION RATES (Q ^{EA})	RATIO SLEVS/Q ^{EA} (R ²)	
1	2	3	4	5	6	7	8	9	10	11	12	13	14
25	Ethylene Dibromide	106-93-4	B2	2.20E-04	5.42E-04	1.84E-05	2.93E-01						
26	Ethylene Dichloride	107-06-2	B2	2.60E-05	6.41E-05	1.56E-04	2.48E+00			2.60E+00	9.10E-01	2.72E+00	2.72E+00
27	Ethylene Oxide	75-21-8	B1	1.00E-04	2.47E-04	4.06E-05	6.44E-01						
28	Formaldehyde	50-00-0	B1	1.30E-05	3.20E-05	3.12E-04	4.95E+00	5.46E+00	9.07E-01				9.07E-01
29	Hexachlorobenzene	118-74-1	B2	4.60E-04	1.13E-03	8.82E-06	1.40E-01						
30	Hexachlorobutadiene	87-68-3	C	2.20E-05	5.42E-05	1.84E-04	2.93E+00						
31	Hexachloroethane	67-72-1	C	4.00E-06	9.86E-06	1.01E-03	1.61E+01						
32	Hydrazine	302-01-2	B2	4.90E-03	1.21E-02	8.28E-07	1.31E-02						
33	Lindane	58-89-9	B2-C	3.80E-04	9.37E-04	1.07E-05	1.69E-01						
34	Methyl Chloride	74-87-3	C	1.80E-06	4.44E-06	2.25E-03	3.58E+01						
35	Methylene Chloride	75-09-2	B2	4.70E-07	1.16E-06	8.63E-03	1.37E+02	1.50E+01	9.11E+00		7.42E+02	1.85E-01	1.85E-01
36	Nickel, metal (dust)	NA	A	2.40E-04	5.92E-04	1.69E-05	2.68E-01	7.36E-02	3.65E+00	5.25E+01	1.58E-03	1.70E+02	3.65E+00
37	Pentaachlorophenol	87-86-5	B2	3.90E-07	9.61E-07	1.04E-02	1.65E+02						
38	Polychlorinated Biphenyl (PCB)	11097-69-1	B2	1.20E-03	2.96E-03	3.38E-06	5.37E-02						
39	Propylene Dichloride	78-87-5	B2	7.20E-07	1.78E-06	5.63E-03	8.94E+01	5.50E+00	1.63E+01				1.63E+01
40	Propylene Oxide	75-56-9	B2	3.70E-06	9.12E-06	1.10E-03	1.74E+01						
41	Styrene	100-42-5	B2	5.70E-07	1.41E-06	7.12E-03	1.13E+02			1.00E-01	3.50E-02	3.23E+03	3.23E+03
42	Toxaphene	8001-35-2	B2	3.20E-04	7.89E-04	1.27E-05	2.01E-01						
43	Tetrachlorethylene	127-18-4	B2	1.40E-05	3.45E-05	2.90E-04	4.60E+00	1.00E+00	4.60E+00				4.60E+00
44	Trichloroethylene	79-01-6	B2	1.00E-05	2.47E-05	4.06E-04	6.44E+00	4.15E+00	1.55E+00		1.12E-01	5.75E+01	1.55E+00
45	Vinyl Chloride	75-01-4	A	8.40E-05	2.07E-04	4.83E-05	7.66E-01						
46	1,1-Dichloroethylene	75-35-4	C	5.00E-05	1.23E-04	8.11E-05	1.29E+00						
47	1,1,2,2-Tetrachloroethane	79-34-5	C	5.80E-05	1.43E-04	6.99E-05	1.11E+00						
48	1,1,1,2-Tetrachloroethane	630-20-6	C	7.40E-06	1.82E-05	5.48E-04	8.70E+00						
49	1,1,2-Trichloroethane	79-00-5	C	1.60E-05	3.94E-05	2.54E-04	4.02E+00	1.66E+00	2.42E+00				2.42E+00
50	1,2-Dibromo-3-Chloropropane	96-12-8	B2	6.90E-07	1.70E-06	5.88E-03	9.33E+01						

TABLE 2 (PART A).—Annual SLEVs of the Carcinogenic Pollutants from TA-3 Facilities-Continued

NO.	CARCINOGENIC POLLUTANTS	CAS NUMBER	CAR. CLASS	UNIT RISK FACTOR (URF) ($\mu\text{g}/\text{m}^3\text{-}1$)	MAXIMUM CANCER RISK ($C_{an} \times \text{URF}$)	ANNUAL SLEVS		RAPS 1990 DATA		NEW EMISSION RATE DATA				THE SMALLER (R^1) OR (R^2) RATIO
						g/sec	lb/yr	ANNUAL EMISSION RATE FROM RAPS (Q_{air})	RATIO SLEVS/ Q_{air} (R^1)	PURCHASED AMOUNT OF CHEMICALS FROM ACS	ESTIMATED ANNUAL EMISSION RATES (Q^{RA})	RATIO SLEVS/ Q^{RA} (R^2)		
1	2	3	4	5	6	7	8	9	10	11	12	13	14	
51	2-Nitropropane	79-46-9	B2	2.70E-03	6.66E-03	1.50E-06	2.38E-02							

Note: The highest ISC-3 estimated annual concentration at sensitive receptors set was found to be 2.465 $\mu\text{g}/\text{m}^3$ when emission rate is 1 g/sec.
 Note: ACS and RAPS databases (LANL 1995a and LANL 1990) indicated that 51 carcinogens had been used in the past. Site information now shows 35 carcinogens in use (Attachment 6, Table C).

TABLE 2 (PART B).—Annual SLEVs of Potentially Sensitive Carcinogenic Pollutants from TA-3

NO.	CARCINOGENIC POLLUTANTS	CAS NUMBER	CAR. CLASS	UNIT RISK FACTOR (URF) ($\mu\text{g}/\text{m}^3\text{-}1$)	MAXIMUM CANCER RISK ($C_{\text{an}} \times \text{URF}$)	ANNUAL SLEVS		RAPS 1990 DATA		NEW EMISSION RATE DATA				THE SMALLER (R^1) OR (R^2) RATIO
						g/sec	lb/yr	ANNUAL EMISSION RATE FROM RAPS ($Q^{\text{a,b}}$) lb/yr	RATIO SLEVS/ $Q^{\text{a,r}}$ (R^1)	PURCHASED AMOUNT OF CHEMICALS FROM ACIS lb/year	ESTIMATED ANNUAL EMISSION RATES ($Q^{\text{a,b}}$) lb/hr	RATIO SLEVS/ $Q^{\text{a,b}}$ (R^2)		
1	2	3	4	5	6	7	8	9	10	11	12	13	14	
1	Benzene	71-43-2	A	8.30E-06	2.05E-05	4.89E-04	7.76E+00				2.37E+00	3.27E+00	3.27E+00	
2	Beryllium	7440-41-7	B2	2.40E-03	5.92E-03	1.69E-06	2.68E-02				1.10E-01	2.44E-01	2.44E-01	
3	Carbon Tetrachloride	56-23-5	B2	1.50E-05	3.70E-05	2.70E-04	4.29E+00	5.00E-01	8.58E+00	1.41E+01	4.94E+00	8.70E-01	8.70E-01	
4	Chloroform	67-66-3	B2	2.30E-05	5.67E-05	1.76E-04	2.80E+00	4.50E-01	6.22E+00		4.52E+00	6.19E-01	6.19E-01	
5	Ethylene Dichloride	107-06-2	B2	2.60E-05	6.41E-05	1.56E-04	2.48E+00			2.60E+00	9.10E-01	2.72E+00	2.72E+00	
6	Formaldehyde	50-00-0	B1	1.30E-05	3.20E-05	3.12E-04	4.95E+00	5.46E+00	9.07E-01				9.07E-01	
7	Methylene Chloride	75-09-2	B2	4.70E-07	1.16E-06	8.63E-03	1.37E+02	1.50E+01	9.11E+00		7.42E+02	1.85E-01	1.85E-01	
8	Nickel, metal (dust)	NA	A	2.40E-04	5.92E-04	1.69E-05	2.68E-01	7.36E-02	3.65E+00	5.25E+01	1.58E-03	1.70E+02	3.65E+00	
9	Propylene Dichloride	78-87-5	B2	7.20E-07	1.78E-06	5.63E-03	8.94E+01	5.50E+00	1.63E+01				1.63E+01	
10	Tetrachlorethylene	127-18-4	B2	1.40E-05	3.45E-05	2.90E-04	4.60E+00	1.00E+00	4.60E+00				4.60E+00	
11	Trichloroethylene	79-01-6	B2	1.00E-05	2.47E-05	4.06E-04	6.44E+00	4.15E+00	1.55E+00		1.12E-01	5.75E+01	1.55E+00	
12	1,1,2-Trichloroethane	79-00-5	C	1.60E-05	3.94E-05	2.54E-04	4.02E+00	1.66E+00	2.42E+00				2.42E+00	

TABLE 2 (PART C).—Annual SLEVs of Potentially Sensitive Carcinogenic Pollutants from Building 16 of TA-3

NO.	CARCINOGENIC POLLUTANTS	CAS NUMBER	CAR. CLASS	UNIT RISK FACTOR (URF) ($\mu\text{g}/\text{m}^3\text{-}^{-1}$)	MAXIMUM CANCER RISK (C _{an} X URF)	ANNUAL SLEVS		RAPS 1990 DATA		NEW EMISSION RATE DATA			THE SMALLER (R ¹) OR (R ²) RATIO
						g/sec	lb/yr	ANNUAL EMISSION RATE FROM RAPS (Q ⁰⁸)	RATIO SLEVS/Q ⁰⁸ (R ¹)	PURCHASED AMOUNT OF CHEMICALS FROM ACIS	ESTIMATED ANNUAL EMISSION RATES (Q ^{0A})	RATIO SLEVS/Q ^{0A} (R ²)	
1	2	3	4	5	6	7	8	9	10	11	12	13	14
1	Chloroform	67-66-3	B2	2.30E-05	5.67E-05	1.76E-04	2.80E+00	4.50E-01	6.22E+00				6.22E+00
2	Chromium VI	18540-29-9	A	1.20E-02	2.96E-02	3.38E-07	5.37E-03	2.00E-02	2.68E-01				2.68E-01
3	Formaldehyde	50-00-0	B1	1.30E-05	3.20E-05	3.12E-04	4.95E+00	6.00E-01	8.25E+00				8.25E+00

TABLE 2 (PART D).—Annual SLEVs of Potentially Sensitive Carcinogenic Pollutants from Building 29 of TA-3

NO.	CARCINOGENIC POLLUTANTS	CAS NUMBER	CAR. CLASS	UNIT RISK FACTOR (URF) ($\mu\text{g}/\text{m}^3\text{-}^{-1}$)	MAXIMUM CANCER RISK (C _{an} X URF)	ANNUAL SLEVS		RAPS 1990 DATA		NEW EMISSION RATE DATA			THE SMALLER (R ¹) OR (R ²) RATIO
						g/sec	lb/yr	ANNUAL EMISSION RATE FROM RAPS (Q ⁰⁸)	RATIO SLEVS/Q ⁰⁸ (R ¹)	PURCHASED AMOUNT OF CHEMICALS FROM ACIS	ESTIMATED ANNUAL EMISSION RATES (Q ^{0A})	RATIO SLEVS/Q ^{0A} (R ²)	
1	2	3	4	5	6	7	8	9	10	11	12	13	14
1	Beryllium	7440-41-7	B2	2.40E-03	5.92E-03	1.69E-06	2.68E-02				3.60E-06	7.45E+03	7.45E+03
2	Formaldehyde	50-00-0	B1	1.30E-05	3.20E-05	3.12E-04	4.95E+00	1.00E-02	4.95E+02				4.95E+02
3	Methylene Chloride	75-09-2	B2	4.70E-07	3.24E-07	3.09E-02	4.90E+02				7.00E+02	7.00E-01	7.00E-01
4	Nickel, metal (dust)	NA	A	2.40E-04	5.92E-04	1.69E-05	2.68E-01	1.10E-03	2.44E+02				2.44E+02

TABLE 2 (PART E).—Annual SLEVs of Potentially Sensitive Carcinogenic Pollutants from Building 30 of TA-3

NO.	CARCINOGENIC POLLUTANTS	CAS NUMBER	CAR. CLASS	UNIT RISK FACTOR (URF) ($\mu\text{g}/\text{m}^3\text{-}1$)	MAXIMUM CANCER RISK ($C_{\text{am}} \times \text{URF}$)	ANNUAL SLEVS		RAPS 1990 DATA		NEW EMISSION RATE DATA				THE SMALLER (R ¹) OR (R ²) RATIO		
						g/sec	lb/yr	ANNUAL EMISSION RATE FROM RAPS (Q ^R)	RATIO SLEVS/ Q ^R (R ¹)	PURCHASED AMOUNT OF CHEMICALS FROM ACIS	ESTIMATED ANNUAL EMISSION RATES (Q ^{EA})	RATIO SLEVS/ Q ^{EA} (R ²)	lb/yr		lb/year	lb/hr
1	Methylene Chloride	75-09-2	B2	4.70E-07	1.16E-06	8.63E-03	1.37E+02	8.25E-00	1.66E+01					1.66E+01	1.66E+01	

TABLE 2 (PART F).—Annual SLEVs of Potentially Sensitive Carcinogenic Pollutants from Building 34 of TA-3

NO.	CARCINOGENIC POLLUTANTS	CAS NUMBER	CAR. CLASS	UNIT RISK FACTOR (URF) ($\mu\text{g}/\text{m}^3\text{-}1$)	MAXIMUM CANCER RISK ($C_{\text{am}} \times \text{URF}$)	ANNUAL SLEVS		RAPS 1990 DATA		NEW EMISSION RATE DATA				THE SMALLER (R ¹) OR (R ²) RATIO		
						g/sec	lb/yr	ANNUAL EMISSION RATE FROM RAPS (Q ^R)	RATIO SLEVS/ Q ^R (R ¹)	PURCHASED AMOUNT OF CHEMICALS FROM ACIS	ESTIMATED ANNUAL EMISSION RATES (Q ^{EA})	RATIO SLEVS/ Q ^{EA} (R ²)	lb/yr		lb/year	lb/hr
1		3	4	5	6	7	8	9	10							
1	Formaldehyde	50-00-0	B1	1.30E-05	3.20E-05	3.12E-04	4.95E+00	1.56E-01	3.17E+01					3.17E+01		
2	Methylene Chloride	75-09-2	B2	4.70E-07	1.16E-06	8.63E-03	1.37E+02							2.87E+01	4.77E+00	
3	Nickel, metal (dust)	NA	A	2.40E-04	5.92E-04	1.69E-05	2.68E-01	2.50E-02	1.07E+01						1.07E+01	

TABLE 2 (PART G).—Annual SLEVs of Potentially Sensitive Carcinogenic Pollutants from Building 37 of TA-3

NO.	CARCINOGENIC POLLUTANTS	CAS NUMBER	CAR. CLASS	UNIT RISK FACTOR (URF)	MAXIMUM CANCER RISK ($C_{in} \times URF$)	ANNUAL SLEVS		RAPS 1990 DATA		NEW EMISSION RATE DATA				THE SMALLER (R^1) OR (R^2) RATIO
						g/sec	lb/yr	lb/yr	lb/yr	ANNUAL EMISSION RATE FROM RAPS (Q^{AR})	RATIO SLEVS/ Q^{AR} (R^1)	PURCHASED AMOUNT OF CHEMICALS FROM ACIS	ESTIMATED ANNUAL EMISSION RATES (Q^{AR})	
1	2	3	4	5	6	7	8	9	10	11	12	13	14	
		127-18-4	B2	$(\mu\text{g}/\text{m}^3)^{-1}$	$3.45\text{E}-05$	$2.90\text{E}-04$	$4.60\text{E}+00$	$1.00\text{E}+00$	$4.60\text{E}+00$				$4.60\text{E}+00$	

TABLE 2 (PART H).—Annual SLEVs of Potentially Sensitive Carcinogenic Pollutants from Building 38 of TA-3

NO.	CARCINOGENIC POLLUTANTS	CAS NUMBER	CAR. CLASS	UNIT RISK FACTOR (URF)	MAXIMUM CANCER RISK ($C_{in} \times URF$)	ANNUAL SLEVS		RAPS 1990 DATA		NEW EMISSION RATE DATA				THE SMALLER (R^1) OR (R^2) RATIO
						g/sec	lb/yr	lb/yr	lb/yr	ANNUAL EMISSION RATE FROM RAPS (Q^{AR})	RATIO SLEVS/ Q^{AR} (R^1)	PURCHASED AMOUNT OF CHEMICALS FROM ACIS	ESTIMATED ANNUAL EMISSION RATES (Q^{AR})	
1	2	3	4	5	6	7	8	9	10	11	12	13	14	
		71-43-2	A	$(\mu\text{g}/\text{m}^3)^{-1}$	$2.05\text{E}-05$	$4.89\text{E}-04$	$7.76\text{E}+00$						$3.40\text{E}+00$	
2	Methylene Chloride	75-09-2	B2	$(\mu\text{g}/\text{m}^3)^{-1}$	$1.16\text{E}-06$	$8.63\text{E}-03$	$1.37\text{E}+02$	$2.78\text{E}+00$	$4.94\text{E}+01$		$2.28\text{E}+00$		$4.94\text{E}+01$	
3	Propylene Dichloride	78-87-5	B2	$(\mu\text{g}/\text{m}^3)^{-1}$	$1.78\text{E}-06$	$5.63\text{E}-03$	$8.94\text{E}+01$	$5.50\text{E}+00$	$1.63\text{E}+01$				$1.63\text{E}+01$	
4	Tetrachloroethylene	127-18-4	B2	$(\mu\text{g}/\text{m}^3)^{-1}$	$3.45\text{E}-05$	$2.90\text{E}-04$	$4.60\text{E}+00$	$1.48\text{E}-08$	$3.11\text{E}+08$				$3.11\text{E}+08$	
5	Trichloroethylene	79-01-6	B2	$(\mu\text{g}/\text{m}^3)^{-1}$	$2.47\text{E}-05$	$4.06\text{E}-04$	$6.44\text{E}+00$	$4.50\text{E}-02$	$1.43\text{E}+02$				$1.43\text{E}+02$	

TABLE 2 (PART I).—Annual SLEVs of Potentially Sensitive Carcinogenic Pollutants from Building 39 of TA-3

NO.	CARCINOGENIC POLLUTANTS	CAS NUMBER	CAR CLASS	UNIT RISK FACTOR (URF) ($\mu\text{g}/\text{m}^3$) ⁻¹	MAXIMUM CANCER RISK ($C_{\text{an}} \times \text{URF}$)	ANNUAL SLEVS		RAPS 1990 DATA		NEW EMISSION RATE DATA				THE SMALLER (R ¹) OR (R ²) RATIO
						g/sec	lb/yr	RATIO SLEVS/ RAPS (R ¹)	ANNUAL EMISSION RATE FROM RAPS (Q ^{RA}) lb/yr	PURCHASED AMOUNT OF CHEMICALS FROM ACIS lb/year	ESTIMATED ANNUAL EMISSION RATES (Q ^{RA}) lb/hr	RATIO SLEVS/ Q ^{RA} (R ²)		
													7	
1	Benzene	71-43-2	A	8.30E-06	2.05E-05	4.89E-04	7.76E+00	1.00E-02	4.95E+02	9.10E-02	8.52E+01	8.52E+01	8.52E+01	
2	Formaldehyde	50-00-0	B1	1.30E-05	3.20E-05	3.12E-04	4.95E+00	1.00E-02	4.95E+02	9.10E-02	8.52E+01	8.52E+01	4.95E+02	

TABLE 2 (PART J).—Annual SLEVs of Potentially Sensitive Carcinogenic Pollutants from Building 40 of TA-3

NO.	CARCINOGENIC POLLUTANTS	CAS NUMBER	CAR CLASS	UNIT RISK FACTOR (URF) ($\mu\text{g}/\text{m}^3$) ⁻¹	MAXIMUM CANCER RISK ($C_{\text{an}} \times \text{URF}$)	ANNUAL SLEVS		RAPS 1990 DATA		NEW EMISSION RATE DATA				THE SMALLER (R ¹) OR (R ²) RATIO
						g/sec	lb/yr	RATIO SLEVS/ RAPS (R ¹)	ANNUAL EMISSION RATE FROM RAPS (Q ^{RA}) lb/yr	PURCHASED AMOUNT OF CHEMICALS FROM ACIS lb/year	ESTIMATED ANNUAL EMISSION RATES (Q ^{RA}) lb/hr	RATIO SLEVS/ Q ^{RA} (R ²)		
													7	
1	2	3	4	5	6	7	8	9	10	11	12	13	14	
1	Carbon Tetrachloride	56-23-5	B2	1.50E-05	3.70E-05	2.70E-04	4.29E+00	5.00E-01	8.58E+00				8.58E+00	
2	Chromium VI	18540-29-9	A	1.20E-02	2.96E-02	3.38E-07	5.37E-03	5.75E-02	9.33E-02				9.33E-02	
3	Formaldehyde	50-00-0	B1	1.30E-05	3.20E-05	3.12E-04	4.95E+00	3.06E-01	1.62E+01				1.62E+01	
4	Methylene Chloride	75-09-2	B2	4.70E-07	1.16E-06	8.63E-03	1.37E-02	5.00E-01	2.74E+02	2.93E+01	1.03E+01	1.33E+01	1.33E+01	
5	Nickel, metal (dust)	N/A	A	2.40E-04	5.92E-04	1.69E-05	2.68E-01	4.75E-02	5.65E+00				5.65E+00	
6	Trichloroethylene	79-01-6	B2	1.00E-05	2.47E-05	4.06E-04	6.44E+00	2.50E+00	2.58E+00				2.58E+00	

TABLE 2 (PART K).—Annual SLEVs of Potentially Sensitive Carcinogenic Pollutants from Building 43 of TA-3

NO.	CARCINOGENIC POLLUTANTS	CAS NUMBER	CAR. CLASS	UNIT RISK FACTOR (URF)	MAXIMUM CANCER RISK (C _{an} X URF)	ANNUAL SLEVS		RAPS 1990 DATA		NEW EMISSION RATE DATA			THE SMALLER (R ¹) OR (R ²) RATIO		
						g/sec	lb/yr	lb/yr	lb/yr	ANNUAL EMISSION RATE FROM RAPS (Q ^{aB})	RATIO SLEVS/ Q ^{aB} (R ¹)	PURCHASED AMOUNT OF CHEMICALS FROM ACIS		ESTIMATED ANNUAL EMISSION RATES (Q ^{aA})	RATIO SLEVS/ Q ^{aA} (R ²)
1	2	3	4	5	6	7	8	9	10	11	12	13	14		
1	Formaldehyde	50-00-0	B1	1.30E-05	3.20E-05	3.12E-04	4.95E+00	5.20E-01	9.52E+00				9.52E+00		
2	Methylene Chloride	75-09-2	B2	4.70E-07	1.16E-06	8.63E-03	1.37E+02	3.00E+00	4.57E+01				4.57E+01		

TABLE 2 (PART L).—Annual SLEVs of Potentially Sensitive Carcinogenic Pollutants from Building 43 510 of TA-3

NO.	CARCINOGENIC POLLUTANTS	CAS NUMBER	CAR. CLASS	UNIT RISK FACTOR (URF)	MAXIMUM CANCER RISK (C _{an} X URF)	ANNUAL SLEVS		RAPS 1990 DATA		NEW EMISSION RATE DATA			THE SMALLER (R ¹) OR (R ²) RATIO		
						g/sec	lb/yr	lb/yr	lb/yr	ANNUAL EMISSION RATE FROM RAPS (Q ^{aB})	RATIO SLEVS/ Q ^{aB} (R ¹)	PURCHASED AMOUNT OF CHEMICALS FROM ACIS		ESTIMATED ANNUAL EMISSION RATES (Q ^{aA})	RATIO SLEVS/ Q ^{aA} (R ²)
1	2	3	4	5	6	7	8	9	10	11	12	13	14		
1	Formaldehyde	50-00-0	B1	1.30E-05	3.20E-05	3.12E-04	4.95E+00	2.17E+00	2.28E+00				2.28E+00		

TABLE 2 (PART M).—Annual SLEVs of Potentially Sensitive Carcinogenic Pollutants from Building 65 of TA-3

NO.	CARCINOGENIC POLLUTANTS	CAS NUMBER	CAR. CLASS	UNIT RISK FACTOR (URF) ($\mu\text{g}/\text{m}^3$) ⁻¹	MAXIMUM CANCER RISK ($C_{\text{an}} \times \text{URF}$)	ANNUAL SLEVS		RAPS 1990 DATA			NEW EMISSION RATE DATA			THE SMALLER (R ¹) OR (R ²) RATIO
						g/sec	lb/yr	ANNUAL EMISSION RATE FROM RAPS (Q ^{aB}) lb/yr	RATIO SLEVS/Q ^{aB} (R ¹)	PURCHASED AMOUNT OF CHEMICALS FROM ACIS lb/year	ESTIMATED ANNUAL EMISSION RATES (Q ^{aA}) lb/hr	RATIO SLEVS/Q ^{aA} (R ²)		
1	2	3	4	5	6	7	8	9	10	11	12	13	14	
1	Trichloroethylene	79-01-6	B2	1.00E-05	2.47E-05	4.06E-04	6.44E+00	1.60E+00	4.02E+00				4.02E+00	

TABLE 2 (PART N).—Annual SLEVs of Potentially Sensitive Carcinogenic Pollutants from Building 66 of TA-3

NO.	CARCINOGENIC POLLUTANTS	CAS NUMBER	CAR. CLASS	UNIT RISK FACTOR (URF) ($\mu\text{g}/\text{m}^3$) ⁻¹	MAXIMUM CANCER RISK ($C_{\text{an}} \times \text{URF}$)	ANNUAL SLEVS		RAPS 1990 DATA			NEW EMISSION RATE DATA			THE SMALLER (R ¹) OR (R ²) RATIO
						g/sec	lb/yr	ANNUAL EMISSION RATE FROM RAPS (Q ^{aB}) lb/yr	RATIO SLEVS/Q ^{aB} (R ¹)	PURCHASED AMOUNT OF CHEMICALS FROM ACIS lb/year	ESTIMATED ANNUAL EMISSION RATES (Q ^{aA}) lb/hr	RATIO SLEVS/Q ^{aA} (R ²)		
1	2	3	4	5	6	7	8	9	10	11	12	13	14	
1	Carbon Tetrachloride	56-23-5	B2	1.50E-05	3.70E-05	2.70E-04	4.29E+00			1.06E+01	3.71E+00	1.16E+00	1.16E+00	
2	Chloroform	67-66-3	B2	2.30E-05	5.67E-05	1.76E-04	2.80E+00			6.60E+01	6.60E-01	4.24E+00	4.24E+00	
3	Formaldehyde	50-00-0	B1	1.30E-05	3.20E-05	3.12E-04	4.95E+00	5.00E-02	9.91E+01				9.91E+01	
4	Methylene Chloride	75-09-2	B2	4.70E-07	1.16E-06	8.63E-03	1.37E+02	5.00E-01	2.74E+02				2.74E+02	
5	Trichloroethylene	79-01-6	B2	1.00E-05	2.47E-05	4.06E-04	6.44E+00	1.66E+00	4.02E+00	3.20E-01	1.12E-01	5.75E+01	5.75E+01	
6	1,1,2-Trichloroethane	79-00-5	C	1.60E-05	3.94E-05	2.54E-04	4.02E+00	1.66E+00	2.42E+00				2.42E+00	

TABLE 2 (PART O).—Annual SLEVs of Potentially Sensitive Carcinogenic Pollutants from Building 70 of TA-3

NO.	CARCINOGENIC POLLUTANTS	CAS NUMBER	CAR. CLASS	UNIT RISK FACTOR (URF)	MAXIMUM CANCER RISK (C _{am} X URF)	ANNUAL SLEVS		RAPS 1990 DATA		NEW EMISSION RATE DATA			THE SMALLER (R ¹) OR (R ²) RATIO
						g/sec	lb/yr	ANNUAL EMISSION RATE FROM RAPS (Q ^{aB})	RATIO SLEVS/Q ^{aB} (R ¹)	PURCHASED AMOUNT OF CHEMICALS FROM ACIS	ESTIMATED ANNUAL EMISSION RATES (Q ^{aA})	RATIO SLEVS/Q ^{aA} (R ²)	
1	2	3	4	5	6	7	8	9	10	11	12	13	14
	Formaldehyde	50-00-0	B1	(µg/m ³) ⁻¹	3.20E-05	3.12E-04	4.95E+00	1.93E-01	2.57E+01				2.57E+01

TABLE 2 (PART P).—Annual SLEVs of Potentially Sensitive Carcinogenic Pollutants from Building 73 of TA-3

NO.	CARCINOGENIC POLLUTANTS	CAS NUMBER	CAR. CLASS	UNIT RISK FACTOR (URF)	MAXIMUM CANCER RISK (C _{am} X URF)	ANNUAL SLEVS		RAPS 1990 DATA		NEW EMISSION RATE DATA			THE SMALLER (R ¹) OR (R ²) RATIO
						g/sec	lb/yr	ANNUAL EMISSION RATE FROM RAPS (Q ^{aB})	RATIO SLEVS/Q ^{aB} (R ¹)	PURCHASED AMOUNT OF CHEMICALS FROM ACIS	ESTIMATED ANNUAL EMISSION RATES (Q ^{aA})	RATIO SLEVS/Q ^{aA} (R ²)	
1	2	3	4	5	6	7	8	9	10	11	12	13	14
	Formaldehyde	50-00-0	B1	(µg/m ³) ⁻¹	3.20E-05	3.12E-04	4.95E+00	5.84E-01	8.49E+00				8.49E+00

TABLE 2 (PART Q).—Annual SLEVs of Potentially Sensitive Carcinogenic Pollutants from Building 102 of TA-3

NO.	CARCINOGENIC POLLUTANTS	CAS NUMBER	CAR. CLASS	UNIT RISK FACTOR (URF) ($\mu\text{g}/\text{m}^3\text{yr}^{-1}$)	MAXIMUM CANCER RISK ($C_{\text{an}} \times \text{URF}$)	ANNUAL SLEVS		RAPS 1990 DATA		NEW EMISSION RATE DATA			THE SMALLER (R ¹) OR (R ²) RATIO
						g/sec	lb/yr	ANNUAL EMISSION RATE FROM RAPS (Q ^{aR}) lb/yr	RATIO SLEVS/ Q ^{aR} (R ¹)	PURCHASED AMOUNT OF CHEMICALS FROM ACIS lb/year	ESTIMATED ANNUAL EMISSION RATES (Q ^{aA}) lb/hr	RATIO SLEVS/ Q ^{aA} (R ²)	
1	2	3	4	5	6	7	8	9	10	11	12	13	14
	Beryllium	7440-41-7	B2	2.40E-03	5.92E-03	1.69E-06	2.68E-02				1.40E-04	1.92E+02	1.92E+02
2	Nickel, metal (dust)	NA	A	2.40E-04	5.92E-04	1.69E-05	2.68E-01			5.25E+01	1.58E-03	1.70E+02	1.70E+02

TABLE 2 (PART R).—Annual SLEVs of Potentially Sensitive Carcinogenic Pollutants from Building 105 of TA-3

NO.	CARCINOGENIC POLLUTANTS	CAS NUMBER	CAR. CLASS	UNIT RISK FACTOR (URF) ($\mu\text{g}/\text{m}^3\text{yr}^{-1}$)	MAXIMUM CANCER RISK ($C_{\text{an}} \times \text{URF}$)	ANNUAL SLEVS		RAPS 1990 DATA		NEW EMISSION RATE DATA			THE SMALLER (R ¹) OR (R ²) RATIO
						g/sec	lb/yr	ANNUAL EMISSION RATE FROM RAPS (Q ^{aR}) lb/yr	RATIO SLEVS/ Q ^{aR} (R ¹)	PURCHASED AMOUNT OF CHEMICALS FROM ACIS lb/year	ESTIMATED ANNUAL EMISSION RATES (Q ^{aA}) lb/hr	RATIO SLEVS/ Q ^{aA} (R ²)	
1	2	3	4	5	6	7	8	9	10	11	12	13	14
	Formaldehyde	50-00-0	B1	1.30E-05	3.20E-05	3.12E-04	4.95E+00	2.50E-01	1.98E+01				1.98E+01

TABLE 2 (PART U).—Annual SLEVs of Potentially Sensitive Carcinogenic Pollutants from Building 287 of TA-3

NO.	CARCINOGENIC POLLUTANTS	CAS NUMBER	CAR. CLASS	UNIT RISK FACTOR (URF) ($\mu\text{g}/\text{m}^3\text{yr}^{-1}$)	MAXIMUM CANCER RISK ($C_{\text{an}} \times \text{URF}$)	ANNUAL SLEVS		RAPS 1990 DATA		NEW EMISSION RATE DATA			THE SMALLER (R ¹) OR (R ²) RATIO
						g/sec	lb/yr	ANNUAL EMISSION RATE FROM RAPS (Q ^{AR}) lb/yr	RATIO SLEVS/ Q ^{AR} (R ¹)	PURCHASED AMOUNT OF CHEMICALS FROM ACIS lb/year	ESTIMATED ANNUAL EMISSION RATES (Q ^{AR}) lb/hr	RATIO SLEVS/ Q ^{AR} (R ²)	
1	2	3	4	5	6	7	8	9	10	11	12	13	14
1	Formaldehyde	50-00-0	B1	1.30E-05	3.20E-05	3.12E-04	4.95E+00	3.00E-01	1.65E+01				1.65E+01

TABLE 2 (PART V).—Annual SLEVs of Potentially Sensitive Carcinogenic Pollutants from Building 1698 of TA-3

NO.	CARCINOGENIC POLLUTANTS	CAS NUMBER	CAR. CLASS	UNIT RISK FACTOR (URF) ($\mu\text{g}/\text{m}^3\text{yr}^{-1}$)	MAXIMUM CANCER RISK ($C_{\text{an}} \times \text{URF}$)	ANNUAL SLEVS		RAPS 1990 DATA		NEW EMISSION RATE DATA			THE SMALLER (R ¹) OR (R ²) RATIO
						g/sec	lb/yr	ANNUAL EMISSION RATE FROM RAPS (Q ^{AR}) lb/yr	RATIO SLEVS/ Q ^{AR} (R ¹)	PURCHASED AMOUNT OF CHEMICALS FROM ACIS lb/year	ESTIMATED ANNUAL EMISSION RATES (Q ^{AR}) lb/hr	RATIO SLEVS/ Q ^{AR} (R ²)	
1	2	3	4	5	6	7	8	9	10	11	12	13	14
1	Carbon Tetrachloride	56-23-5	B2	1.50E-05	3.70E-05	2.70E-04	4.29E+00			3.50E+00	1.23E+00	3.50E+00	3.50E+00
2	Chloroform	67-66-3	B2	2.30E-05	5.67E-05	1.76E-04	2.80E+00			1.15E+02	1.38E+00	2.03E+00	2.03E+00
3	Ethylene Dichloride	107-06-2	B2	2.60E-05	6.41E-05	1.56E-04	2.48E+00			2.60E+00	9.10E-01	2.72E+00	2.72E+00
4	Methylene Chloride	75-09-2	B2	4.70E-07	1.16E-06	8.63E-03	1.37E+02			5.80E+00	2.03E+00	6.75E+01	6.75E+01
5	Styrene	100-42-5	B2	5.70E-07	1.41E-06	7.12E-03	1.13E+02			1.00E+01	3.50E-02	3.23E+03	3.23E+03

TABLE 2 (PART W).—Annual SLEVs of Potentially Sensitive Carcinogenic Pollutants from Building 495 of TA-3

NO.	CARCINOGENIC POLLUTANTS	CAS NUMBER	CAR. CLASS	UNIT RISK FACTOR (URF) ($\mu\text{g}/\text{m}^3\text{-}1$)	MAXIMUM CANCER RISK ($C_{\text{an}} \times \text{URF}$)	ANNUAL SLEVS		RAPS 1990 DATA		NEW EMISSION RATE DATA			THE SMALLER (R ¹) OR (R ²) RATIO
						g/sec	lb/yr	ANNUAL EMISSION RATE FROM RAPS (Q ^{ar}) lb/yr	RATIO SLEVS/ Q ^{ar} (R ¹)	PURCHASED AMOUNT OF CHEMICALS FROM ACIS	ESTIMATED ANNUAL EMISSION RATES (Q ^{ra}) lb/hr	RATIO SLEVS/ Q ^{ra} (R ²)	
1	2	3	4	5	6	7	8	9	10	11	12	13	14
1	Formaldehyde	50-00-0	B1	1.30E-05	3.20E-05	3.12E-04	4.95E+00	3.00E-01	1.65E+01				1.65E+01

TABLE 2 (PART X).—Annual SLEVs of Potentially Sensitive Carcinogenic Pollutants from Building 1819 of TA-3

NO.	CARCINOGENIC POLLUTANTS	CAS NUMBER	CAR. CLASS	UNIT RISK FACTOR (URF) ($\mu\text{g}/\text{m}^3\text{-}1$)	MAXIMUM CANCER RISK ($C_{\text{an}} \times \text{URF}$)	ANNUAL SLEVS		RAPS 1990 DATA		NEW EMISSION RATE DATA			THE SMALLER (R ¹) OR (R ²) RATIO
						g/sec	lb/yr	ANNUAL EMISSION RATE FROM RAPS (Q ^{ar}) lb/yr	RATIO SLEVS/Q ^{ar} (R ¹)	PURCHASED AMOUNT OF CHEMICALS FROM ACIS	ESTIMATED ANNUAL EMISSION RATES (Q ^{ra}) lb/hr	RATIO SLEVS/ Q ^{ra} (R ²)	
1	2	3	4	5	6	7	8	9	10	11	12	13	14
1	Chloroform	67-66-3	B2	2.30E-05	5.67E-05	1.76E-04	2.80E+00			1.16E+02	2.48E+00	1.13E+00	1.13E+00
2	Methylene Chloride	75-09-2	B2	4.70E-07	1.16E-06	8.63E-03	1.37E+02			2.93E+00	1.03E+00	1.33E+02	1.33E+02

ATTACHMENT 6

ADDITIVE IMPACT ANALYSIS ASSOCIATED WITH THE COMBINED RELEASES OF CARCINOGENIC POLLUTANTS FROM ALL TECHNICAL AREAS

Technical Area(s): TA-00, TA-2, TA-3, TA-5, TA-8, TA-9, TA-11, TA-15, TA-16, TA-18, TA-21, TA-22, TA-33, TA-35, TA-36, TA-39, TA-40, TA-41, TA-43, TA-46, TA-48, TA-50, TA-51, TA-53, TA-54, TA-55, TA-59, TA-60, TA-61, and TA-64

Emission Sources

Releases of Noncarcinogenic and Carcinogenic Air Pollutants From All LANL TAs

Title III of the *Clean Air Act* (CAA) Amendments of 1990 sets a framework for regulating sources of toxic air pollutants. According to the provisions of the CAA, “after the implementation of the maximum achievable control technology, it is necessary to assess the residual risks due to toxic air emissions to the population near each source of emissions.”

This assessment includes the determination of noncancer health effects of noncarcinogenic air pollutants based on the estimation of long-term and short-term ambient concentrations of these pollutants, and the determination of lifetime cancer risk exposure of carcinogenic air pollutants based on the estimation of long-term ambient concentrations of these pollutants. The determination involves performing analytical (modeling) simulations of the air pollutants dispersion for all emission sources of concern. Such simulations are then coupled with health effects information and compared to available population data to quantify human exposure, noncancer health risk, cancer risk, and ecological risks.

For carcinogenic air pollutants, the level of concern is the risk of an individual contracting cancer by being exposed to ambient concentrations of that pollutant over the course of a lifetime, or lifetime cancer risk. The criteria specified in the CAA is 1.0×10^{-6} (1 in 1,000,000) lifetime cancer risk for the individual exposed to the highest predicted concentration of a pollutant. Lifetime cancer risk is estimated by multiplying the predicted annual ambient concentration (in micrograms per cubic meter) of a specific pollutant by the unit risk factor for that pollutant, where the unit risk factor is equal to the upper bound lifetime cancer risk associated with inhaling a unit concentration (1 microgram per cubic meter) of that pollutant.

EPA has developed unit risk factors for a number of possible, probable, or known human carcinogens, which are available from its Integrated Risk Information System (IRIS) database.

According to EPA 1992f, “cancer risks resulting from exposure to mixtures of multiple carcinogenic pollutants are to be assessed by summing the incremental cancer risks due to each individual pollutant, regardless of the type of cancer that may be associated with any particular carcinogen. Thus, this approach assumes that all cancer risks are additive and all worst-case impacts occur at the same location. While this assumption may not be very realistic, it does help to insure that results are conservative, and, therefore protective to the public.”

Pollutant(s) Considered

Noncarcinogenic Pollutants

An analysis of potential short-term impacts at a TA's fence line receptors showed that the 8-hour impacts from the releases of that TA were significantly greater (i.e., more than two orders of magnitude) than the impacts from the releases of a nearby TA. This is because the TAs are relatively far apart in comparison to the distances between the emission sources of a TA and its fence line receptors. Therefore, it is unlikely that the additive short-term impacts of noncarcinogenic pollutants at the fence line receptors of a TA would be significantly different from the maximum concentrations previously estimated for that TA.

An analysis of annual potential impacts at sensitive receptors showed that these impacts were significantly less (i.e., less than two orders of magnitude) relative to the appropriate Guideline Values (GVs) than the corresponding short-term impacts at the fence line receptors. Therefore, it is unlikely that the additive annual impacts of the noncarcinogenic pollutants at the sensitive receptors would be significant.

Carcinogenic Pollutants

All carcinogenic air pollutants that are currently being used at LANL or are anticipated to be used under the future alternatives were included in the additive impact analysis.

TA-2, TA-5, TA-11, TA-36, TA-40, TA-41, and TA-64 do not currently use carcinogenic pollutants and do not anticipate using them under the future alternatives. As such, these TAs were not included in the additive impact evaluation.

Emission Rates of Pollutants Considered

Annual emission rates of the carcinogenic pollutants used were those developed for both key and non-key facilities for each pollutant that had an SLEV/Q ratio less than one, based on process knowledge and chemical usage for the Expanded Operations Alternative. For those carcinogenic pollutants released from key or non-key facilities, within both key and non-key TAs, for which such emission data were not specifically developed for this analysis, emission rates were estimated based on data either from the RAPS Report or ACIS database, or were assumed to be at SLEV levels.

Beryllium emissions from all LANL sources (i.e., TA-3 CMR Building 29, TA-3 Machine Shops Complex, TA-35 Building 213, and TA-55 Building 15 Chemical Laboratory) were modeled using LANL's permitted emission rates.

Estimated emission rates of each of the carcinogenic pollutants considered in the additive impacts analysis for releases of all carcinogenic pollutants from all TAs are presented in Table A.

Dispersion Modeling Analysis

The additive impact analysis was conducted with the EPA's ISC-3 Model using 5 years of on-site meteorological data. All buildings near emission sources within the zone of influence at each TA were included in the downwash effects evaluation.

The incremental cancer risk from the release of a pollutant was estimated by multiplying the maximum ISC-3-estimated annual average concentration of that pollutant by its unit risk factor.

Major Assumptions Used in the Dispersion Analysis

- Emissions would be released simultaneously from LANL operations over 8,760 hours a year.
- Incremental cancer risks are additive.
- There is no reduction of the ambient concentrations by entry into buildings and deposition within them.

Results

Releases of Each Carcinogenic Pollutant from All TAs

The potential additive impact of the emissions of each of the carcinogenic pollutants from all of the TAs was estimated by assuming that each pollutant was emitted from all of the TAs at the SLEV levels. The maximum receptor for the release from each TA was added to the maximum receptor from each of the other TAs. This analysis was conducted for one of the pollutants, and the results were applied to each of the other pollutants. This approach is legitimate because the relationship between SLEVs and GVs are identical for all of the pollutants for each TA due to the fact that they are based on the same dispersion-related X/Q (concentration related to the emissions) ratio.

Results of the analysis are presented in Table B. For illustrational purposes, the cancer risk associated with the releases of three pollutants (arsenic, benzene, and formaldehyde) at their SLEV release rates are shown in Table B.

As shown, the combined cancer risk associated with releases of each of these pollutants from all TAs is 1.23×10^{-7} , which is below the GV of 1.0×10^{-6} .

Releases of All Carcinogenic Pollutants from All TAs

A total of 35 carcinogenic pollutants were considered in the additive impacts analysis of emissions of all carcinogenic pollutants from all of the TAs. These are the carcinogenic pollutants that are currently being used at LANL or are anticipated to be used under the site's future alternatives. The annual average concentrations of each pollutant were estimated assuming that all pollutants were emitted simultaneously from all of the TAs.

The maximum concentration of each pollutant from the simultaneous release from all TAs was determined by modeling the emission rates from Table A and recording the highest concentration from a listing of 180 receptors. The combined cancer risk was then estimated by summing up the cancer risk of each individual pollutant at these (maximum) concentrations, even though the receptors may

have been different. This value was then compared with an allowable incremental cancer risk of 1.0×10^{-6} . Results of this analysis are presented in Table C. As shown, the potential combined incremental cancer risk associated with releases of all carcinogenic pollutants from all TAs is above the GV of 1.0×10^{-6} .

Because the predicted combined additive impact of all carcinogenic pollutants released from all TAs is above the specified GV of 1.0×10^{-6} , a more detailed analysis that considered the impact at each receptor locations was conducted. This more refined analysis estimated the combined cancer risk at each of the 180 sensitive receptor locations with a focus on the pollutants with the greatest contribution to the combined cancer risk from the previous step.

For each of these critical pollutants (chloroform, formaldehyde, methylene chloride, and trichloethylene), the maximum cancer risk was estimated at each of the 180 receptor locations using the highest values of the annual concentrations estimated using 5 years of meteorological data for that receptor. Cancer risk values at receptors #28 and #175 through #180 (the highest values) were computed for all the other chemicals, also using the highest value of the annual concentration estimated using 5 years of meteorological data for those receptors. For receptors other than those just mentioned, default values of the maximum concentration of any of the receptors were recorded in Table D for each of the chemicals other than the four critical pollutants.

As shown in Table D, the combined incremental cancer risk associated with releases of all carcinogenic pollutants from all TAs at the receptor locations where these impacts actually occur are above the GV of 1.0×10^{-6} at the two locations within the LANL Medical Center, 1.17×10^{-6} at Receptor #175 (air intake duct at a height of 3.7 feet [12.2 meters]) and 1.07×10^{-6} at Receptor #180 (an operable window at a height of 0.46 feet [1.5 meters]).

The major contributors to the estimated combined cancer risk values are pollutants primarily released from TA-43, the Health Research Laboratory (HRL). The critical pollutants are chloroform, formaldehyde, and trichloethylene from the HRL and methylene chloride from multiple sources (TA-3, TA-9, TA-16, TA-35, TA-46, and TA-48). The estimated maximum cancer risk for each of these individual pollutants is 8.74×10^{-7} , 5.17×10^{-8} , 6.73×10^{-8} , and 6.84×10^{-8} , respectively. Of these, the relative contribution of chloroform emissions alone to the combined cancer risk value is more than 87 percent.

The impacts of TA-43 emissions are due to a combination of relatively high emission rates, close proximity between receptors and sources, and the elevation of the receptors. Receptors at or near the Medical Center, where these impacts are estimated, are #28 and #175 through 180 in attachment 3, Sensitive Receptors. Receptor #28 is a ground level receptor. Receptors #175 through 180 are elevated (i.e., air intakes at a height of up to 3.7 feet [12 meters] and operable windows at a height of 0.46 feet [1.5 meters] above the ground) and are at the distance of less than 30.5 feet (100 meters) from the nearest stack on the roof of the HRL.

Because the estimated cancer risk at these two receptor locations is above the GV of 1.0×10^{-6} , these results are subject to a risk assessment analysis.

TABLE A (PART 1).—Emission Rates of the Carcinogenic Pollutants Considered in the Additive Impact Analysis

NO.		POLLUTANTS		KEY BUILDINGS OF THE TA-3 FACILITY															
				TA-3 SIGMA (BLDG. 66)				TA-3 CMR (BLDG. 29)				TA-3 MSL (BLDG. 1098)				TA-3 SHOP COMPLEX (BLDG. 102 & 141)			
				SLEV/O RATIOS		EMISSION RATES		SLEV/O RATIOS		EMISSION RATES		SLEV/O RATIOS		EMISSION RATES		SLEV/O RATIOS		EMISSION RATES	
				ORIGINAL	REVISED	AT THE SLEV LEVEL	USED IN THE ANALYSIS	ORIGINAL	REVISED	AT THE SLEV LEVEL	USED IN THE ANALYSIS	ORIGINAL	REVISED	AT THE SLEV LEVEL	USED IN THE ANALYSIS	ORIGINAL	REVISED	AT THE SLEV LEVEL	USED IN THE ANALYSIS
		g/sec	g/sec			g/sec	g/sec			g/sec	g/sec			g/sec	g/sec	g/sec	g/sec		
1																			
2																			
3																			
4																			
5																			
6																			
7																			
8																			
9																			
10																			
11																			
12																			
13																			
14																			
15																			
16																			
17																			
18																			
19																			
20																			
21																			
22																			
23																			
24																			
25																			
26																			
27																			
28																			

TABLE A (PART 1).—Emission Rates of the Carcinogenic Pollutants Considered in the Additive Impact Analysis-Continued

KEY BUILDINGS OF THE TA-3 FACILITY																
NO.	POLLUTANTS	TA-3 SIGMA (BLDG. 66)				TA-3 CMR (BLDG. 29)				TA-3 MSL (BLDG. 1698)				TA-3 SHOP COMPLEX (BLDG. 102 & 141)		
		SLEV/O RATIOS		EMISSION RATES		SLEV/O RATIOS		EMISSION RATES		SLEV/O RATIOS		EMISSION RATES		EMISSION RATES USED IN THE ANALYSIS		
		ORIGINAL	REVISED	AT THE SLEV LEVEL	USED IN THE ANALYSIS	ORIGINAL	REVISED	AT THE SLEV LEVEL	USED IN THE ANALYSIS	ORIGINAL	REVISED	AT THE SLEV LEVEL	USED IN THE ANALYSIS	BLDG. 102	BLDG. 141	
				g/sec	g/sec			g/sec	g/sec			g/sec	g/sec	g/sec	g/sec	
29	Methylene Chloride					8.34E+00	7.03E-01			3.34E+01	6.70E+01					
30	Nickel, metal (dust)													2.27E-08		
31	Propylene Dichloride															
32	Styrene															
33	Tetrachlorethylene															
34	Trichloroethylene	1.71E-01	5.75E+01		1.61E-06											
35	Vinyl Chloride															
19	Diethanolamine															
20	Epichlorohydrin															
21	Ethyl Acrylate															
22	Ethylene Dichloride															
23	Ethylene Oxide															
24	Formaldehyde															
25	Hexachlorobutadiene															
26	Hexachloroethane															
27	Hydrazine															
28	Methyl Chloride															
29	Methylene Chloride					7.70E+01	--									
30	Nickel, metal (dust)															
31	Propylene Dichloride															
32	Styrene															
33	Tetrachlorethylene															
34	Trichloroethylene															
35	Vinyl Chloride															

TABLE A (PART 2).—Emission Rates of the Carcinogenic Pollutants Considered in the Additive Impact Analysis

NO.	POLLUTANTS	NON-KEY BUILDINGS TA-3				TA-40				TA-8				TA-9				
		EMISSION RATES USED IN THE ANALYSIS		TA TOTAL BUILDING(S) CONSIDERED	SLEV/Q RATIOS		EMISSION RATES		SLEV/Q RATIOS		EMISSION RATES		SLEV/Q RATIOS		EMISSION RATES			
		BY BUILDING	g/sec		BY BUILDING	g/sec	ORIGINAL	REVISED	AT THE SLEV LEVEL	USED IN THE ANALYSIS	g/sec	g/sec	ORIGINAL	REVISED	AT THE SLEV LEVEL	USED IN THE ANALYSIS	g/sec	g/sec
1	1,1,1,2-Tetrachloroethane																	
2	1,1,2,2-Tetrachloroethane																	
3	1,1,2-Trichloroethane		2.39E-05	Bldg. 66											1.38E+02	--	8.70E-04	8.70E-04
4	1,3-Butadiene																	
5	2,3,7,8-Tetrachlorodibenzo(p)dioxin																	
6	2-Nitropropane																	
7	Acetaldehyde		1.84E-03															
8	Acrylamide																	
9	Allyl Chloride																	
10	Arsenic		9.43E-07															
11	Benzene	3.2825E-05	1.3101E-06	Bldg. 38 ^b Bldg. 39 ^c											1.06E+04	--	1.68E-03	1.68E-03
12	Benzo(p)pyrene																	
13	Benzyl Chloride																	
14	Beryllium ^a																	
15	Cadmium																	
16	Carbon Tetrachloride	7.20E-06		Bldg. 40											2.94E+04	--	9.28E-04	9.28E-04
17	Chloroform	6.48E-06	3.57E-05	Bldg. 16 ^b Bldg. 181 ^{9c}											1.40E+00	--	6.05E-04	6.05E-04
18	Chromium VI																	
19	Diethanolamine																	
20	Epichlorohydrin																	
21	Ethyl Acrylate		8.11E-03															
22	Ethylene Dichloride																	
23	Ethylene Oxide																	
24	Formaldehyde		7.86E-05	15 Bldgs.										1.16E+02	--	5.49E-04	5.49E-04	
25	Hexachlorobutadiene																	
26	Hexachloroethane																	
27	Hydrazine														4.51E-02	2.04E+01		3.17E-08

TABLE A (PART 2).—Emission Rates of the Carcinogenic Pollutants Considered in the Additive Impact Analysis-Continued

NO.	POLLUTANTS	NON-KEY BUILDINGS TA-3						TA-8				TA-9					
		EMISSION RATES USED IN THE ANALYSIS						SLEW/Q RATIOS		EMISSION RATES		SLEW/Q RATIOS		EMISSION RATES			
		BY BUILDING	BY BUILDING	TA TOTAL	BUILDING(S) CONSIDERED	ORIGINAL	REVISED	AT THE SLEW LEVEL	USED IN THE ANALYSIS	ORIGINAL	REVISED	AT THE SLEW LEVEL	USED IN THE ANALYSIS	ORIGINAL	REVISED	AT THE SLEW LEVEL	USED IN THE ANALYSIS
		g/sec	g/sec	g/sec				g/sec	g/sec			g/sec	g/sec			g/sec	g/sec
28	Methyl Chloride																
29	Methylene Chloride			7.85E-04	7 Bldgs.	7.70E+01	--	9.70E-03	9.70E-03					6.66E+01	--	2.96E-02	2.96E-02
30	Nickel, metal (dust)			1.06E-06	3 Bldgs.												
31	Propylene Dichloride			5.63E-03													
32	Styrene			7.12E-03													
33	Tetrachlorethylene		--	2.90E-04													
34	Trichloroethylene			5.97E-05	4 Bldgs.									2.21E+02	--	1.39E-03	1.39E-03
35	Vinyl Chloride																

TABLE A (PART 3).—Emission Rates of the Carcinogenic Pollutants Considered in the Additive Impact Analysis

NO.	POLLUTANTS	TA-15				TA-16				TA-21				TA-22			
		SLEW/Q RATIOS		EMISSION RATES		SLEW/Q RATIOS		EMISSION RATES		SLEW/Q RATIOS		EMISSION RATES		SLEW/Q RATIOS		EMISSION RATES	
		ORIGINAL	REVISED	AT THE SLEW LEVEL	USED IN THE ANALYSIS	ORIGINAL	REVISED	AT THE SLEW LEVEL	USED IN THE ANALYSIS	ORIGINAL	REVISED	AT THE SLEW LEVEL	USED IN THE ANALYSIS	ORIGINAL	REVISED	AT THE SLEW LEVEL	USED IN THE ANALYSIS
				g/sec	g/sec			g/sec	g/sec			g/sec	g/sec			g/sec	g/sec
1	1,1,1,2-Tetrachloroethane																
2	1,1,2,2-Tetrachloroethane													1.42E+02	--	4.35E-05	4.35E-05
3	1,1,2-Trichloroethane				new pol.												
4	1,3-Butadiene				new pol. fr. incinerator												
5	2,3,7,8-Tetrachlorodibenzofuran (p)dioxin																
6	2-Nitropropane																
7	Acetaldehyde																
8	Acrylamide																
9	Allyl Chloride																
10	Arsenic					1.06E-08											
11	Benzene																
12	Benzo(a)pyrene													9.65E+00	--	3.04E-04	3.04E-04
13	Benzyl Chloride																

TABLE A (PART 3).—Emission Rates of the Carcinogenic Pollutants Considered in the Additive Impact Analysis-Continued

NO.	POLLUTANTS	TA-15				TA-16				TA-21				TA-22				
		SLEV/Q RATIOS		EMISSION RATES		SLEV/Q RATIOS		EMISSION RATES		SLEV/Q RATIOS		EMISSION RATES		SLEV/Q RATIOS		EMISSION RATES		
		ORIGINAL	REVISED	AT THE SLEV LEVEL	USED IN THE ANALYSIS	ORIGINAL	REVISED	AT THE SLEV LEVEL	USED IN THE ANALYSIS	ORIGINAL	REVISED	AT THE SLEV LEVEL	USED IN THE ANALYSIS	ORIGINAL	REVISED	AT THE SLEV LEVEL	USED IN THE ANALYSIS	
		g/sec	g/sec			g/sec	g/sec			g/sec	g/sec			g/sec	g/sec			
14	Beryllium ^a																	
15	Cadmium																	
16	Carbon Tetrachloride																	
17	Chloroform																	
18	Chromium VI																	
19	Diethanolamine																	
20	Epichlorohydrin																	
21	Ethyl Acrylate																	
22	Ethylene Dichloride	9.73E+00	--	1.23E-03	1.23E-03													
23	Ethylene Oxide																	
24	Formaldehyde																	
25	Hexachlorobutadiene																	
26	Hexachloroethane																	
27	Hydrazine																	
28	Methyl Chloride																	
29	Methylene Chloride																	
30	Nickel, metal (dust)																	
31	Propylene Dichloride																	
32	Styrene																	
33	Tetrachlorethylene																	
34	Trichloroethylene	3.37E+00	--	3.19E-03	3.19E-03													
35	Vinyl Chloride																	

TABLE A (PART 4).—Emission Rates of the Carcinogenic Pollutants Considered in the Additive Impact Analysis

NO.	POLLUTANTS	TA-35				TA-39				TA-43				TA-46			
		SLEV/Q RATIOS		EMISSION RATES		SLEV/Q RATIOS		EMISSION RATES		EMISSION RATES USED IN THE ANALYSIS		SLEV/Q RATIOS		EMISSION RATES			
		ORIGINAL	REVISED	AT THE SLEV LEVEL	USED IN THE ANALYSIS	ORIGINAL	REVISED	AT THE SLEV LEVEL	USED IN THE ANALYSIS	BLDG. 247	BLDG. 124/126	N-SIDE	S-SIDE	ORIGINAL	REVISED	AT THE SLEV LEVEL	USED IN THE ANALYSIS
1	1,1,1,2-Tetrachloroethane																
2	1,1,1,2,2-Tetrachloroethane	2.08E+01	--	2.62E-04	2.62E-04												
3	1,1,1,2-Trichloroethane																
4	1,3-Butadiene	new pol.	8.61E+01		1.44E-07								2.72E+00	--	5.39E-05	5.39E-05	
5	2,3,7,8-Tetrachlorodibenzo(p)dioxin																
6	2-Nitropropane	new pol.	4.47E+01		2.88E-08								1.16E+00	--	5.59E-06	5.59E-06	
7	Acetaldehyde																
8	Acrylamide	new pol.			6.62E-08			8.44E-08	8.44E-08	8.44E-08	8.44E-08						
9	Allyl Chloride																
10	Arsenic			3.53E-06													
11	Benzene	1.45E+02	-	1.83E-03	1.83E-03								4.25E+02	--	1.82E-03	1.82E-03	
12	Benzo(a)pyrene																
13	Benzyl Chloride			1.27E-03													
14	Beryllium ^a				1.15E-08												
15	Cadmium																
16	Carbon Tetrachloride	1.61E+02	--	1.01E-03	1.01E-03								1.30E+01	--	1.01E-03	1.01E-03	
17	Chloroform	5.36E-01	1.95E+01		7.75E-06	1.41E+02	--	1.42E-04	1.42E-04	3.17E-05	3.07E-04	3.07E-04	6.29E-01	2.21E+01		6.80E-06	
18	Chromium VI																
19	Diethanolamine														1.37E-01		
20	Epichlorohydrin																
21	Ethyl Acrylate																
22	Ethylene Dichloride	1.94E+00	--	5.84E-04	5.84E-04								9.64E+00	--	5.81E-04	5.81E-04	
23	Ethylene Oxide																
24	Formaldehyde												2.49E-06	2.42E-05	2.42E-05	2.42E-05	
25	Hexachlorobutadiene																
26	Hexachloroethane																
27	Hydrazine																
28	Methyl Chloride					1.87E+04	--	6.95E-03	6.95E-03				8.33E+02	--	8.39E-03	8.39E-03	
29	Methylene Chloride	2.04E+01	--	3.23E-02	3.23E-02							1.36E-05	1.66E+01	--	3.21E-02	3.21E-02	
30	Nickel, metal (dust)												2.27E+05	--	6.29E-05	6.29E-05	

TABLE A (PART 4).—Emission Rates of the Carcinogenic Pollutants Considered in the Additive Impact Analysis-Continued

NO.	POLLUTANTS	TA-35			TA-39			TA-43			TA-46				
		SLEV/Q RATIOS		EMISSION RATES	SLEV/Q RATIOS		EMISSION RATES	EMISSION RATES USED IN THE ANALYSIS		SLEV/Q RATIOS		EMISSION RATES			
		ORIGINAL	REVISED	AT THE SLEV LEVEL ANALYSIS	USED IN THE ANALYSIS	ORIGINAL	REVISED	AT THE SLEV LEVEL ANALYSIS	USED IN THE ANALYSIS	BLDG. 247	BLDG. 124/126	N.SIDE	S.SIDE	AT THE SLEV LEVEL ANALYSIS	USED IN THE ANALYSIS
		g/sec	g/sec			g/sec	g/sec	g/sec	g/sec	g/sec	g/sec	g/sec	g/sec	g/sec	
31	Propylene Dichloride														
32	Styrene			2.67E-02											
33	Tetrachlorethylene	1.72E+02	--	1.09E-03	1.09E-03										
34	Trichloroethylene	5.62E-01	3.05E+00	5.27E-05	8.30E+01	--	3.27E-04	3.27E-04	1.47E-04	1.08E+01	--	1.51E-03	1.51E-03	1.51E-03	
35	Vinyl Chloride			1.81E-04											

TABLE A (PART 5).—Emission Rates of the Carcinogenic Pollutants Considered in the Additive Impact Analysis

NO.	POLLUTANTS	TA-48			TA-50			TA-53			TA-54		
		SLEV/Q RATIOS		EMISSION RATES	SLEV/Q RATIOS		EMISSION RATES	SLEV/Q RATIOS		EMISSION RATES	SLEV/Q RATIOS		EMISSION RATES
		ORIGINAL	REVISED	AT THE SLEV LEVEL ANALYSIS	USED IN THE ANALYSIS	ORIGINAL	REVISED	AT THE SLEV LEVEL ANALYSIS	USED IN THE ANALYSIS	ORIGINAL	REVISED	AT THE SLEV LEVEL ANALYSIS	USED IN THE ANALYSIS
		g/sec	g/sec			g/sec	g/sec	g/sec	g/sec	g/sec	g/sec	g/sec	
1	1,1,1,2-Tetrachloroethane			4.58E-04									
2	1,1,2,2-Tetrachloroethane	1.47E+02	--	9.07E-08									
3	1,1,2-Trichloroethane	7.22E+01	--	2.21E-04	2.21E-04								
4	1,3-Butadiene	8.74E+00		3.17E-07									
5	2,3,7,8-Tetrachlorodibenzo(p)dioxin												
6	2-Nitropropane												
7	Acetaldehyde												
8	Acrylamide												
9	Allyl Chloride												
10	Arsenic												
11	Benzene	9.55E-01	3.34E+01	2.79E-06	7.73E-01	5.41E+00	2.10E-05	5.96E+00	--	1.53E-03	1.53E-03	1.53E-03	1.53E-03
12	Benzo(a)pyrene												
13	Benzyl Chloride												
14	Beryllium ^a												

TABLE A (PART 5).—Emission Rates of the Carcinogenic Pollutants Considered in the Additive Impact Analysis-Continued

NO.	POLLUTANTS	TA-48				TA-50				TA-53				TA-54					
		SLEV/Q RATIOS		EMISSION RATES		SLEV/Q RATIOS		EMISSION RATES		SLEV/Q RATIOS		EMISSION RATES		SLEV/Q RATIOS		EMISSION RATES			
		ORIGINAL	REVISED	AT THE SLEV LEVEL	USED IN THE ANALYSIS	ORIGINAL	REVISED	AT THE SLEV LEVEL	USED IN THE ANALYSIS	ORIGINAL	REVISED	AT THE SLEV LEVEL	USED IN THE ANALYSIS	ORIGINAL	REVISED	AT THE SLEV LEVEL	USED IN THE ANALYSIS		
		g/sec	g/sec			g/sec	g/sec			g/sec	g/sec			g/sec	g/sec				
15	Cadmium					1.70E+01	--	8.56E-06	8.56E-06										
16	Carbon Tetrachloride		2.93E+00		1.77E-05					1.74E+02	--	2.75E-04	2.75E-04	2.19E+01	--	8.47E-04	8.47E-04		
17	Chloroform	2.56E-01	8.97E+00		3.76E-06					2.24E-01	--	2.35E-04	2.35E-04	1.92E-01	5.48E+00			2.30E-05	
18	Chromium VI																		
19	Diethanolamine																		
20	Epichlorohydrin												3.43E-03						
21	Ethyl Acrylate																		
22	Ethylene Dichloride	4.33E+00	--	1.30E-04	1.30E-04					5.25E+00	--	1.58E-04	1.58E-04	8.10E+00	--	4.88E-04	4.88E-04		
23	Ethylene Oxide																		
24	Formaldehyde	1.03E+01	--	2.61E-04	2.61E-04														
25	Hexachlorobutadiene			1.54E-04															
26	Hexachloroethane			8.48E-04															
27	Hydrazine																		
28	Methyl Chloride																		
29	Methylene Chloride	1.15E+03	--	7.22E-03	7.22E-03					3.87E+00	--	8.76E-03	8.76E-03	8.36E-01	3.57E+03			1.73E-06	
30	Nickel, metal (dust)	2.34E-01	3.74E+01		8.78E-08					1.45E+00	--	1.72E-05	1.72E-05						
31	Propylene Dichloride																		
32	Styrene				5.95E-03														
33	Tetrachlorethylene	3.08E+01	--	2.42E-04	2.42E-04														
34	Trichloroethylene	4.78E+01	--	3.39E-04	3.39E-04	1.63E+01	--	1.54E-03	1.54E-03										
35	Vinyl Chloride																		

TABLE A (PART 6).—Emission Rates of the Carcinogenic Pollutants Considered in the Additive Impact Analysis

NO.	POLLUTANTS	TA-55				TA-59				TA-60				TA-61				
		SLEV/Q RATIOS		EMISSION RATES		SLEV/Q RATIOS		EMISSION RATES		SLEV/Q RATIOS		EMISSION RATES		SLEV/Q RATIOS		EMISSION RATES		
		ORIGINAL	REVISED	AT THE SLEV LEVEL	USED IN THE ANALYSIS	ORIGINAL	REVISED	AT THE SLEV LEVEL	USED IN THE ANALYSIS	ORIGINAL	REVISED	AT THE SLEV LEVEL	USED IN THE ANALYSIS	ORIGINAL	REVISED	AT THE SLEV LEVEL	USED IN THE ANALYSIS	
		g/sec	g/sec			g/sec	g/sec			g/sec	g/sec			g/sec	g/sec			
1	1,1,1,2-Tetrachloroethane																	
2	1,1,1,2,2-Tetrachloroethane																	
3	1,1,1,2-Trichloroethane	3.88E+01	--	9.30E-04	9.30E-04													
4	1,3-Butadiene																	
5	2,3,7,8-Tetrachlorodibenzop(dioxin)																	
6	2-Nitropropane																	
7	Acetaldehyde																	
8	Acrylamide	8.24E+02	--	1.15E-05	1.15E-05													
9	Allyl Chloride																	
10	Arsenic																	
11	Benzene	8.38E+01	2.94E+04		1.40E-08												1.73E-05	
12	Benzo(a)pyrene																	
13	Benzyl Chloride																	
14	Beryllium ^a																	
15	Cadmium	3.97E+03	--	8.27E-06	8.27E-06													
16	Carbon Tetrachloride	1.54E+01	1.29E+01		1.77E-05	5.63E+01	--	3.55E-04	3.55E-04								1.54E-06	1.54E-06
17	Chloroform	5.62E-01	8.90E+00		1.67E-05													
18	Chromium VI	8.93E+00	--	1.24E-06	1.24E-06													
19	Diethanolamine																	
20	Epichlorohydrin																	
21	Ethyl Acrylate																	
22	Ethylene Dichloride																	
23	Ethylene Oxide																	
24	Formaldehyde	1.82E+04	--	1.15E-03	1.15E-03	1.62E+01	--	4.09E-04	4.09E-04									
25	Hexachlorobutadiene																	
26	Hexachloroethane																	
27	Hydrazine	4.33E+00	--	3.04E-06	3.04E-06													
28	Methyl Chloride																	
29	Methylene Chloride	3.06E+01	4.95E+02		1.47E-05	8.64E-02	1.53E+03										7.87E+00	1.36E-03
30	Nickel, metal (dust)	3.28E+04	--	6.20E-05	6.20E-05													

TABLE A (PART 6).—Emission Rates of the Carcinogenic Pollutants Considered in the Additive Impact Analysis-Continued

NO.	POLLUTANTS	TA-55				TA-59				TA-60				TA-61			
		SLEV/Q RATIOS		EMISSION RATES		SLEV/Q RATIOS		EMISSION RATES		SLEV/Q RATIOS		EMISSION RATES		SLEV/Q RATIOS		EMISSION RATES	
		ORIGINAL	REVISED	AT THE SLEV LEVEL	USED IN THE ANALYSIS	ORIGINAL	REVISED	AT THE SLEV LEVEL	USED IN THE ANALYSIS	ORIGINAL	REVISED	AT THE SLEV LEVEL	USED IN THE ANALYSIS	ORIGINAL	REVISED	AT THE SLEV LEVEL	USED IN THE ANALYSIS
				g/sec	g/sec			g/sec	g/sec			g/sec	g/sec			g/sec	g/sec
31	Propylene Dichloride																
32	Styrene																
33	Tetrachlorethylene	1.13E+01	1.34E+01	1.81E-05													
34	Trichloroethylene	9.23E-02	2.11E+01	1.61E-05	5.63E+00	--	5.32E-04	5.32E-04	4.39E+00	--	2.77E-04	2.77E-04					
35	Vinyl Chloride																

Notes: TA-2, TA-5, TA-11, TA-36, TA-40, TA-41, and TA-64, which are not currently using any of the carcinogenic pollutants or are anticipated to use them under future alternatives, were not included in the analysis.

^a Beryllium emissions from all sources (i.e., TA-3 CMR Building 29, TA-3 Shop Complex, TA-35 Building 213, and TA-55 Building 15 Chemical Lab.), were modeled using LANL's permitted emission rates.

^b Annual emission rates of carcinogenic pollutants were estimated based on detailed evaluation of actual operating conditions. These revised emission rates were developed for both key and non-key buildings, within key and non-key buildings, for each pollutant that had an SLEV/Q ratio less than 1. For those pollutants released from key or non-key buildings, within both key and non-key buildings, for which such emission data were not developed, emission rates were estimated based on data either from the RAPS-90 (LANL 1990) Report or ACIS 1996 database (LANL 1995a), or were assumed to be at SLEV levels.

^c It was assumed that emissions would be released simultaneously over 8,760 hours a year.

TABLE B.—Results of the Additive Impact Analysis of the Cancer Risk Associated with Releases of Each Carcinogenic Pollutant from All TAs Combined

NO.	LANL TAs	ANNUAL SLEVS ^a		
		ARSENIC	BENZENE	FORMALDEHYDE
		g/sec	g/sec	g/sec
1	TA-00	1.06E-06	5.49E-04	3.15E-04
2	TA-2	4.67E-07	2.42E-04	1.54E-04
3	TA-3	9.43E-07	4.89E-04	3.12E-04
4	TA-5	3.03E-06	1.57E-03	1.00E-03
5	TA-8	1.66E-06	8.59E-04	5.49E-04
6	TA-9	3.24E-06	1.68E-03	1.07E-03
7	TA-11	2.70E-06	1.40E-03	8.92E-04
8	TA-15	7.42E-06	3.84E-03	2.45E-03
9	TA-16	2.95E-06	1.53E-03	9.77E-04
10	TA-18	4.68E-06	2.41E-03	1.54E-03
11	TA-21	5.86E-07	3.04E-04	1.94E-04
12	TA-22	3.95E-06	2.05E-03	1.31E-03
13	TA-33	2.09E-06	1.08E-03	6.92E-04
14	TA-35	3.53E-06	1.83E-03	1.17E-03
15	TA-36	5.85E-06	3.03E-03	1.93E-03
16	TA-39	7.60E-07	3.94E-04	2.51E-04
17	TA-40	3.84E-06	1.99E-03	1.27E-03
18	TA-41	4.31E-07	2.23E-04	1.42E-04
19	TA-43	1.38E-08	7.13E-06	4.55E-06
20	TA-46	3.51E-06	1.82E-03	1.16E-03
21	TA-48	7.89E-07	4.09E-04	2.61E-04
22	TA-50	3.59E-06	1.86E-03	1.19E-03
23	TA-51	3.24E-06	1.68E-03	1.07E-03

TABLE B.—Results of the Additive Impact Analysis of the Cancer Risk Associated with Releases of Each Carcinogenic Pollutant from All TAs Combined—Continued

NO.	LANL TAs	ANNUAL SLEVS ^a		
		ARSENIC	BENZENE	FORMALDEHYDE
		g/sec	g/sec	g/sec
24	TA-53	9.58E-07	4.96E-04	3.17E-04
25	TA-54	2.95E-06	1.53E-03	9.77E-04
26	TA-55	3.46E-06	1.79E-03	1.15E-03
27	TA-59	1.24E-06	6.41E-04	4.09E-04
28	TA-60	6.43E-07	3.33E-04	2.13E-04
29	TA-61	5.71E-07	2.96E-04	1.89E-04
30	TA-64	1.50E-06	7.79E-04	4.97E-04
SUMMARY				
Estimated Annual Concentration ^b from Releases of Each Pollutant from All TAs, (C _{an}), µg/m ³		2.82E-05	1.49E-02	9.49E-03
Unit Risk Factors ^c (URF), (µg/m ³) ⁻¹		4.35E-03	8.30E-06	1.30E-05
Maximum Incremental Cancer Risk ^d (C _{an} x URF)		1.23E-07	1.23E-07	1.23E-07
Guideline Value ^e		1.00E-06	1.00E-06	1.00E-06

Major Assumptions:

^a Annual emission rates at the SLEV levels were used in the additive impacts analysis.

^b Annual average concentration (C_{an}) is the highest concentration estimated by the ISC-3 model at any of the sensitive receptor locations using 5 years of on-site meteorological data.

^c Unit risk factors are from the EPA's Integrated Risk Information System (IRIS) database (EPA 1993b).

^d Maximum cancer risk of each pollutant was estimated by multiplying the annual concentration of that pollutant by its unit risk factor (EPA 1992f and EPA 1993b). Total combined incremental cancer risk was estimated by summing the cancer risks due to each individual pollutant released from all TAs.

^e The guideline value of 1.0E-06 (1.0 x 10⁻⁶), established by Title III of the *Clean Air Act Amendments of 1990* (CAAA) as a level of concern, is associated with a life time exposure to carcinogenic pollutants (EPA 1992f).

TABLE C.—Total Combined Cancer Risks of All Carcinogenic Pollutants from All TAs (Regardless of the Receptor Locations Where Maximum Values Are Estimated)

NO.	CARCINOGENIC POLLUTANTS ^a	ISC-3 ESTIMATED HIGHEST ANNUAL POLLUTANT CONCENTRATION (C _{an}) ^b µg/m ³	UNIT RISK FACTORS (URF) ^c		MAXIMUM CANCER RISK DUE TO EACH POLLUTANT (C _{an} x URF) ^d
			(µg/m ³) ⁻¹		
1	1,1,1,2-Tetrachloroethane	1.32E-03	7.40E-06		9.77E-09
2	1,1,2,2-Tetrachloroethane	3.10E-04	5.80E-05		1.80E-08
3	1,1,2-Trichloroethane	2.44E-03	1.60E-05		3.90E-08
4	1,3-Butadiene	3.00E-05	2.80E-04		8.40E-09
5	2-Nitropropane	4.00E-05	2.70E-03		1.08E-07
6	Acetaldehyde	5.16E-03	2.20E-06		1.14E-08
7	Acrylamide	1.56E-05	1.30E-03		2.02E-08
8	Allyl Chloride	1.79E-01	5.50E-08		9.86E-09
9	Arsenic	2.84E-06	4.30E-03		1.22E-08
10	Benzene	3.67E-03	8.30E-06		3.05E-08
11	Benzo(p)pyrene	1.70E-07	1.70E-03		2.89E-10
12	Benzyl Chloride	8.40E-04	1.20E-05		1.01E-08
13	Beryllium	1.10E-06	2.40E-03		2.64E-09
14	Cadmium	1.59E-05	1.80E-03		2.86E-08
15	Carbon Tetrachloride	2.56E-03	1.50E-05		3.84E-08
16	2,3,7,8-tetrachlorodibenzo(p)dioxin	1.70E-11	3.30E+01		5.61E-10
17	Chloroform	3.80E-02	2.30E-05		8.74E-07
18	Chromium VI	8.35E-07	1.20E-02		1.00E-08
19	Diethanolamine	7.64E-02	1.10E-07		8.40E-09
20	Epichlorohydrin	8.33E-03	1.20E-06		1.00E-08
21	Ethyl Acrylate	2.73E-02	5.00E-07		1.37E-08
22	Ethylene Dichloride	1.83E-03	2.60E-05		4.76E-08

TABLE C.—Total Combined Cancer Risks of All Carcinogenic Pollutants from All TAs (Regardless of the Receptor Locations Where Maximum Values Are Estimated)-Continued

NO.	CARCINOGENIC POLLUTANTS ^a	ISC-3 ESTIMATED HIGHEST ANNUAL POLLUTANT CONCENTRATION (C _{an}) ^b µg/m ³	UNIT RISK FACTORS (URF) ^c (µg/m ³) ⁻¹		MAXIMUM CANCER RISK DUE TO EACH POLLUTANT (C _{an} x URF) ^d
23	Ethylene Oxide	1.00E-04	1.00E-04		1.00E-08
24	Formaldehyde	3.98E-03	1.30E-05		5.17E-08
25	Hexachlorobutadiene	4.30E-04	2.20E-05		9.46E-09
26	Hexachloroethane	2.45E-03	4.00E-06		9.80E-09
27	Hydrazine	3.30E-06	4.90E-03		1.62E-08
28	Methyl Chloride	2.22E-02	1.80E-06		3.99E-08
29	Methylene Chloride	1.45E-01	4.70E-07		6.84E-08
30	Nickel, metal (dust)	9.95E-05	2.40E-04		2.39E-08
31	Propylene Dichloride	1.57E-02	7.20E-07		1.13E-08
32	Styrene	3.45E-02	5.70E-07		1.97E-08
33	Tetrachloroethylene	1.41E-03	1.40E-05		1.97E-08
34	Trichloroethylene	6.73E-03	1.00E-05		6.73E-08
35	Vinyl Chloride	1.20E-04	8.40E-05		1.01E-08
Total Combined Cancer Risk of All Pollutants ^e					1.67E-06
Guideline Value ^f					1.00E-06

Notes:

Major Assumptions:

^a The total of 35 carcinogenic pollutants that have the potential to be released from LANL operations were considered in the additive impact analysis. Emission rates of these pollutants are presented in Table A.

^b ISC-3 estimated annual concentration is the highest concentration at any of the sensitive receptor locations using 5 years on-site of meteorological data.

^c Unit risk factors are from the EPA's Integrated Risk Information System (IRIS) database (EPA 1993b).

^d Maximum cancer risk was obtained by multiplying of the estimated annual concentration of a specific pollutant by its unit risk factor (EPA 1992f and EPA 1993b).

^e The total potential combined cancer risks were estimated by summing the cancer risks due to each individual pollutant released from LANL operations, regardless of the location where maximum values are estimated.

^f The guideline value of 1.0E-06 (1.0 x 10⁻⁶), established by Title III of the *Clean Air Act Amendments of 1990* (CAAA) as a level of concern, is associated with a life time exposure to carcinogenic pollutants (EPA 1992f).

TABLE D (PART 1).—Total Combined Cancer Risk of All Pollutants from All TAs

NO.	1		2		3		4		5		6		7		8		9		10		11		12	
	CHLF	FORM	TRCE	MECH	Be	MITCH	ETDC	CCL4	Ni	BENZ	ACAL	ETAC	Max. CR	Max. CR	Max. CR	Max. CR	Max. CR	Max. CR	Max. CR	Max. CR	Max. CR	Max. CR	Max. CR	Max. CR
1	2.58E-08	2.09E-08	2.70E-08	3.48E-08	7.37E-10	6.59E-09	3.82E-08	3.12E-08	2.39E-08	3.05E-08	1.14E-08	1.37E-08	3.82E-08	3.12E-08	2.39E-08	3.05E-08	1.14E-08	1.37E-08	3.82E-08	3.12E-08	2.39E-08	3.05E-08	1.14E-08	1.37E-08
2	2.55E-08	2.87E-08	3.49E-08	3.52E-08	1.03E-09	6.66E-09	3.28E-08	2.73E-08	2.39E-08	3.05E-08	1.14E-08	1.37E-08	3.28E-08	2.73E-08	2.39E-08	3.05E-08	1.14E-08	1.37E-08	3.28E-08	2.73E-08	2.39E-08	3.05E-08	1.14E-08	1.37E-08
3	2.05E-08	2.18E-08	2.91E-08	2.98E-08	1.15E-09	5.92E-09	2.78E-08	2.01E-08	2.39E-08	3.05E-08	1.14E-08	1.37E-08	2.78E-08	2.01E-08	2.39E-08	3.05E-08	1.14E-08	1.37E-08	2.78E-08	2.01E-08	2.39E-08	3.05E-08	1.14E-08	1.37E-08
4	2.19E-08	2.09E-08	2.88E-08	2.89E-08	1.25E-09	5.18E-09	2.47E-08	1.79E-08	2.39E-08	3.05E-08	1.14E-08	1.37E-08	2.47E-08	1.79E-08	2.39E-08	3.05E-08	1.14E-08	1.37E-08	2.47E-08	1.79E-08	2.39E-08	3.05E-08	1.14E-08	1.37E-08
5	2.39E-08	2.26E-08	3.12E-08	3.15E-08	1.35E-09	5.31E-09	2.60E-08	1.86E-08	2.39E-08	3.05E-08	1.14E-08	1.37E-08	2.60E-08	1.86E-08	2.39E-08	3.05E-08	1.14E-08	1.37E-08	2.60E-08	1.86E-08	2.39E-08	3.05E-08	1.14E-08	1.37E-08
6	2.53E-08	2.17E-08	3.03E-08	3.01E-08	1.40E-09	5.04E-09	2.39E-08	1.70E-08	2.39E-08	3.05E-08	1.14E-08	1.37E-08	2.39E-08	1.70E-08	2.39E-08	3.05E-08	1.14E-08	1.37E-08	2.39E-08	1.70E-08	2.39E-08	3.05E-08	1.14E-08	1.37E-08
7	2.90E-08	2.41E-08	3.37E-08	3.39E-08	1.56E-09	5.22E-09	2.55E-08	1.76E-08	2.39E-08	3.05E-08	1.14E-08	1.37E-08	2.55E-08	1.76E-08	2.39E-08	3.05E-08	1.14E-08	1.37E-08	2.55E-08	1.76E-08	2.39E-08	3.05E-08	1.14E-08	1.37E-08
8	2.69E-08	2.04E-08	2.82E-08	2.96E-08	1.37E-09	4.68E-09	2.24E-08	1.52E-08	2.39E-08	3.05E-08	1.14E-08	1.37E-08	2.24E-08	1.52E-08	2.39E-08	3.05E-08	1.14E-08	1.37E-08	2.24E-08	1.52E-08	2.39E-08	3.05E-08	1.14E-08	1.37E-08
9	2.74E-08	1.87E-08	2.55E-08	2.67E-08	1.30E-09	4.30E-09	2.05E-08	1.38E-08	2.39E-08	3.05E-08	1.14E-08	1.37E-08	2.05E-08	1.38E-08	2.39E-08	3.05E-08	1.14E-08	1.37E-08	2.05E-08	1.38E-08	2.39E-08	3.05E-08	1.14E-08	1.37E-08
10	3.45E-08	2.12E-08	2.99E-08	3.89E-08	1.61E-09	4.97E-09	2.16E-08	1.44E-08	2.39E-08	3.05E-08	1.14E-08	1.37E-08	2.16E-08	1.44E-08	2.39E-08	3.05E-08	1.14E-08	1.37E-08	2.16E-08	1.44E-08	2.39E-08	3.05E-08	1.14E-08	1.37E-08
11	4.12E-08	2.04E-08	3.01E-08	4.87E-08	1.68E-09	5.44E-09	2.13E-08	1.37E-08	2.39E-08	3.05E-08	1.14E-08	1.37E-08	2.13E-08	1.37E-08	2.39E-08	3.05E-08	1.14E-08	1.37E-08	2.13E-08	1.37E-08	2.39E-08	3.05E-08	1.14E-08	1.37E-08
12	3.80E-08	1.96E-08	2.87E-08	4.23E-08	1.60E-09	5.04E-09	2.03E-08	1.31E-08	2.39E-08	3.05E-08	1.14E-08	1.37E-08	2.03E-08	1.31E-08	2.39E-08	3.05E-08	1.14E-08	1.37E-08	2.03E-08	1.31E-08	2.39E-08	3.05E-08	1.14E-08	1.37E-08
13	3.66E-08	1.79E-08	2.61E-08	3.38E-08	1.48E-09	4.57E-09	1.85E-08	1.20E-08	2.39E-08	3.05E-08	1.14E-08	1.37E-08	1.85E-08	1.20E-08	2.39E-08	3.05E-08	1.14E-08	1.37E-08	1.85E-08	1.20E-08	2.39E-08	3.05E-08	1.14E-08	1.37E-08
14	3.17E-08	1.66E-08	2.40E-08	2.66E-08	1.34E-09	4.48E-09	1.77E-08	1.16E-08	2.39E-08	3.05E-08	1.14E-08	1.37E-08	1.77E-08	1.16E-08	2.39E-08	3.05E-08	1.14E-08	1.37E-08	1.77E-08	1.16E-08	2.39E-08	3.05E-08	1.14E-08	1.37E-08
15	3.29E-08	1.65E-08	2.38E-08	2.65E-08	1.36E-09	4.48E-09	1.74E-08	1.14E-08	2.39E-08	3.05E-08	1.14E-08	1.37E-08	1.74E-08	1.14E-08	2.39E-08	3.05E-08	1.14E-08	1.37E-08	1.74E-08	1.14E-08	2.39E-08	3.05E-08	1.14E-08	1.37E-08
16	3.45E-08	1.65E-08	2.40E-08	2.91E-08	1.38E-09	4.52E-09	1.74E-08	1.14E-08	2.39E-08	3.05E-08	1.14E-08	1.37E-08	1.74E-08	1.14E-08	2.39E-08	3.05E-08	1.14E-08	1.37E-08	1.74E-08	1.14E-08	2.39E-08	3.05E-08	1.14E-08	1.37E-08
17	4.07E-08	1.95E-08	2.84E-08	4.79E-08	1.66E-09	5.22E-09	2.00E-08	1.29E-08	2.39E-08	3.05E-08	1.14E-08	1.37E-08	2.00E-08	1.29E-08	2.39E-08	3.05E-08	1.14E-08	1.37E-08	2.00E-08	1.29E-08	2.39E-08	3.05E-08	1.14E-08	1.37E-08
18	4.67E-08	2.13E-08	3.15E-08	6.22E-08	1.83E-09	6.14E-09	2.24E-08	1.46E-08	2.39E-08	3.05E-08	1.14E-08	1.37E-08	2.24E-08	1.46E-08	2.39E-08	3.05E-08	1.14E-08	1.37E-08	2.24E-08	1.46E-08	2.39E-08	3.05E-08	1.14E-08	1.37E-08
19	4.69E-08	1.90E-08	2.80E-08	6.84E-08	1.70E-09	5.56E-09	1.95E-08	1.31E-08	2.39E-08	3.05E-08	1.14E-08	1.37E-08	1.95E-08	1.31E-08	2.39E-08	3.05E-08	1.14E-08	1.37E-08	1.95E-08	1.31E-08	2.39E-08	3.05E-08	1.14E-08	1.37E-08
20	4.49E-08	1.87E-08	2.74E-08	5.34E-08	1.66E-09	5.26E-09	1.92E-08	1.25E-08	2.39E-08	3.05E-08	1.14E-08	1.37E-08	1.92E-08	1.25E-08	2.39E-08	3.05E-08	1.14E-08	1.37E-08	1.92E-08	1.25E-08	2.39E-08	3.05E-08	1.14E-08	1.37E-08
21	4.74E-08	1.70E-08	2.53E-08	4.45E-08	1.66E-09	5.06E-09	1.82E-08	1.25E-08	2.39E-08	3.05E-08	1.14E-08	1.37E-08	1.82E-08	1.25E-08	2.39E-08	3.05E-08	1.14E-08	1.37E-08	1.82E-08	1.25E-08	2.39E-08	3.05E-08	1.14E-08	1.37E-08
22	4.58E-08	1.64E-08	2.44E-08	3.52E-08	1.65E-09	4.84E-09	1.74E-08	1.19E-08	2.39E-08	3.05E-08	1.14E-08	1.37E-08	1.74E-08	1.19E-08	2.39E-08	3.05E-08	1.14E-08	1.37E-08	1.74E-08	1.19E-08	2.39E-08	3.05E-08	1.14E-08	1.37E-08
23	3.84E-08	1.43E-08	2.09E-08	2.19E-08	1.53E-09	3.74E-09	1.51E-08	1.04E-08	2.39E-08	3.05E-08	1.14E-08	1.37E-08	1.51E-08	1.04E-08	2.39E-08	3.05E-08	1.14E-08	1.37E-08	1.51E-08	1.04E-08	2.39E-08	3.05E-08	1.14E-08	1.37E-08
24	5.98E-08	1.79E-08	2.71E-08	3.05E-08	1.89E-09	6.19E-09	1.79E-08	1.26E-08	2.39E-08	3.05E-08	1.14E-08	1.37E-08	1.79E-08	1.26E-08	2.39E-08	3.05E-08	1.14E-08	1.37E-08	1.79E-08	1.26E-08	2.39E-08	3.05E-08	1.14E-08	1.37E-08
25	1.13E-07	1.72E-08	2.41E-08	1.76E-08	1.87E-09	9.09E-09	1.38E-08	1.07E-08	2.39E-08	3.05E-08	1.14E-08	1.37E-08	1.38E-08	1.07E-08	2.39E-08	3.05E-08	1.14E-08	1.37E-08	1.38E-08	1.07E-08	2.39E-08	3.05E-08	1.14E-08	1.37E-08
26	9.94E-08	1.50E-08	2.09E-08	1.49E-08	1.50E-09	5.92E-09	1.17E-08	9.15E-09	2.39E-08	3.05E-08	1.14E-08	1.37E-08	1.17E-08	9.15E-09	2.39E-08	3.05E-08	1.14E-08	1.37E-08	1.17E-08	9.15E-09	2.39E-08	3.05E-08	1.14E-08	1.37E-08

TABLE D (PART 1).—Total Combined Cancer Risk of All Pollutants from All TAs-Continued

NO.	1	2	3	4	5	6	7	8	9	10	11	12
REC. #	CHLF	FORM	TRCE	MECH	Be	MTCB	ETDC	CCL4	Ni	BENZ	ACAL	ETAC
	Max. CR	Max. CR	Max. CR	Max. CR	Max. CR	Max. CR	Max. CR	Max. CR	Max. CR	Max. CR	Max. CR	Max. CR
27	2.22E-07	2.24E-08	2.87E-08	1.80E-08	1.83E-09	9.95E-09	1.35E-08	1.08E-08	2.39E-08	3.05E-08	1.14E-08	1.37E-08
28	5.17E-07	3.61E-08	4.42E-08	2.03E-08	1.78E-09	1.07E-08	1.43E-08	1.14E-08	3.16E-08	7.47E-09	1.01E-08	8.92E-09
29	2.67E-07	2.29E-08	2.98E-08	1.67E-08	1.39E-09	5.76E-09	1.25E-08	9.60E-09	2.39E-08	3.05E-08	1.14E-08	1.37E-08
30	1.87E-07	1.85E-08	2.42E-08	1.61E-08	1.27E-09	4.90E-09	1.20E-08	9.15E-09	2.39E-08	3.05E-08	1.14E-08	1.37E-08
31	1.15E-07	1.47E-08	1.99E-08	1.52E-08	1.14E-09	4.10E-09	1.12E-08	8.55E-09	2.39E-08	3.05E-08	1.14E-08	1.37E-08
32	1.13E-07	1.50E-08	2.07E-08	1.49E-08	1.39E-09	5.15E-09	1.12E-08	8.70E-09	2.39E-08	3.05E-08	1.14E-08	1.37E-08
33	3.82E-08	1.00E-08	1.33E-08	1.30E-08	6.26E-10	1.73E-09	1.09E-08	8.55E-09	2.39E-08	3.05E-08	1.14E-08	1.37E-08
34	4.81E-08	1.07E-08	1.53E-08	1.18E-08	1.08E-09	3.28E-09	9.88E-09	7.20E-09	2.39E-08	3.05E-08	1.14E-08	1.37E-08
35	3.20E-08	8.58E-09	1.24E-08	1.02E-08	8.74E-10	2.32E-09	8.84E-09	6.75E-09	2.39E-08	3.05E-08	1.14E-08	1.37E-08
36	2.94E-08	8.71E-09	1.26E-08	9.91E-09	8.86E-10	2.38E-09	9.36E-09	6.75E-09	2.39E-08	3.05E-08	1.14E-08	1.37E-08
37	2.44E-08	9.62E-09	1.36E-08	1.10E-08	9.96E-10	2.65E-09	9.62E-09	6.75E-09	2.39E-08	3.05E-08	1.14E-08	1.37E-08
38	2.83E-08	1.25E-08	1.84E-08	1.79E-08	1.28E-09	3.10E-09	1.35E-08	9.15E-09	2.39E-08	3.05E-08	1.14E-08	1.37E-08
39	2.00E-08	7.41E-09	9.90E-09	9.05E-09	5.74E-10	1.49E-09	8.06E-09	6.00E-09	2.39E-08	3.05E-08	1.14E-08	1.37E-08
40	1.56E-08	6.37E-09	8.80E-09	7.98E-09	5.04E-10	1.35E-09	7.02E-09	5.10E-09	2.39E-08	3.05E-08	1.14E-08	1.37E-08
41	1.63E-08	6.50E-09	9.10E-09	7.85E-09	5.88E-10	1.40E-09	7.02E-09	5.25E-09	2.39E-08	3.05E-08	1.14E-08	1.37E-08
42	1.01E-08	5.20E-09	7.30E-09	6.32E-09	3.74E-10	1.01E-09	6.24E-09	4.35E-09	2.39E-08	3.05E-08	1.14E-08	1.37E-08
43	1.61E-08	7.28E-09	1.07E-08	8.78E-09	7.22E-10	1.80E-09	8.06E-09	5.70E-09	2.39E-08	3.05E-08	1.14E-08	1.37E-08
44	1.13E-08	7.28E-09	1.06E-08	9.10E-09	6.82E-10	1.89E-09	8.58E-09	5.55E-09	2.39E-08	3.05E-08	1.14E-08	1.37E-08
45	1.27E-08	8.71E-09	1.24E-08	1.09E-08	7.87E-10	2.25E-09	1.01E-08	6.60E-09	2.39E-08	3.05E-08	1.14E-08	1.37E-08
46	1.54E-08	1.03E-08	1.43E-08	1.28E-08	8.57E-10	2.43E-09	1.17E-08	7.80E-09	2.39E-08	3.05E-08	1.14E-08	1.37E-08
47	1.89E-08	1.18E-08	1.68E-08	1.53E-08	9.48E-10	2.84E-09	1.33E-08	8.85E-09	2.39E-08	3.05E-08	1.14E-08	1.37E-08
48	1.54E-08	1.08E-08	1.56E-08	1.39E-08	7.99E-10	2.75E-09	1.27E-08	8.70E-09	2.39E-08	3.05E-08	1.14E-08	1.37E-08
49	1.40E-08	1.34E-08	1.80E-08	1.68E-08	7.42E-10	3.76E-09	1.77E-08	1.29E-08	2.39E-08	3.05E-08	1.14E-08	1.37E-08
50	1.15E-08	8.58E-09	1.19E-08	1.06E-08	6.65E-10	2.20E-09	1.01E-08	6.75E-09	2.39E-08	3.05E-08	1.14E-08	1.37E-08
51	1.08E-08	9.36E-09	1.33E-08	1.14E-08	5.86E-10	2.88E-09	1.22E-08	8.55E-09	2.39E-08	3.05E-08	1.14E-08	1.37E-08
52	1.08E-08	9.49E-09	1.36E-08	1.18E-08	6.00E-10	2.93E-09	1.25E-08	8.85E-09	2.39E-08	3.05E-08	1.14E-08	1.37E-08

TABLE D (PART 1).—Total Combined Cancer Risk of All Pollutants from All TAs-Continued

NO.	1	2	3	4	5	6	7	8	9	10	11	12
REC.#	CHLF	FORM	TRCE	MECH	Be	MTCH	ETDC	CCL4	Ni	BENZ	ACAL	ETAC
	Max. CR	Max. CR	Max. CR	Max. CR	Max. CR	Max. CR	Max. CR	Max. CR	Max. CR	Max. CR	Max. CR	Max. CR
53	1.10E-08	1.04E-08	1.41E-08	1.37E-08	5.30E-10	3.35E-09	1.43E-08	1.02E-08	2.39E-08	3.05E-08	1.14E-08	1.37E-08
54	6.44E-09	8.32E-09	1.21E-08	1.04E-08	3.29E-10	4.21E-09	1.48E-08	1.07E-08	2.39E-08	3.05E-08	1.14E-08	1.37E-08
55	7.13E-09	9.49E-09	1.37E-08	1.19E-08	3.67E-10	4.75E-09	1.69E-08	1.23E-08	2.39E-08	3.05E-08	1.14E-08	1.37E-08
56	7.13E-09	9.88E-09	1.42E-08	1.23E-08	3.86E-10	4.88E-09	1.74E-08	1.28E-08	2.39E-08	3.05E-08	1.14E-08	1.37E-08
57	7.36E-09	1.07E-08	1.51E-08	1.30E-08	4.10E-10	5.02E-09	1.85E-08	1.35E-08	2.39E-08	3.05E-08	1.14E-08	1.37E-08
58	7.59E-09	1.08E-08	1.54E-08	1.33E-08	4.18E-10	5.04E-09	1.92E-08	1.41E-08	2.39E-08	3.05E-08	1.14E-08	1.37E-08
59	7.82E-09	1.20E-08	1.70E-08	1.41E-08	4.37E-10	5.63E-09	2.05E-08	1.52E-08	2.39E-08	3.05E-08	1.14E-08	1.37E-08
60	7.82E-09	1.17E-08	1.77E-08	1.38E-08	4.37E-10	6.17E-09	2.03E-08	1.52E-08	2.39E-08	3.05E-08	1.14E-08	1.37E-08
61	7.36E-09	1.09E-08	1.66E-08	1.28E-08	4.10E-10	6.23E-09	1.85E-08	1.40E-08	2.39E-08	3.05E-08	1.14E-08	1.37E-08
62	6.90E-09	9.23E-09	1.37E-08	1.12E-08	3.58E-10	4.72E-09	1.51E-08	1.10E-08	2.39E-08	3.05E-08	1.14E-08	1.37E-08
63	6.90E-09	9.62E-09	1.49E-08	1.14E-08	3.74E-10	5.47E-09	1.61E-08	1.20E-08	2.39E-08	3.05E-08	1.14E-08	1.37E-08
64	6.90E-09	9.88E-09	1.54E-08	1.16E-08	3.79E-10	5.67E-09	1.66E-08	1.23E-08	2.39E-08	3.05E-08	1.14E-08	1.37E-08
65	7.59E-09	1.11E-08	1.73E-08	1.27E-08	4.13E-10	6.53E-09	1.87E-08	1.35E-08	2.39E-08	3.05E-08	1.14E-08	1.37E-08
66	7.13E-09	9.36E-09	1.51E-08	1.08E-08	3.65E-10	6.43E-09	1.59E-08	1.07E-08	2.39E-08	3.05E-08	1.14E-08	1.37E-08
67	7.82E-09	9.75E-09	1.62E-08	1.15E-08	3.62E-10	7.04E-09	1.61E-08	1.05E-08	2.39E-08	3.05E-08	1.14E-08	1.37E-08
68	8.05E-09	1.07E-08	1.78E-08	1.26E-08	3.91E-10	7.24E-09	1.82E-08	1.17E-08	2.39E-08	3.05E-08	1.14E-08	1.37E-08
69	7.13E-09	7.67E-09	1.49E-08	8.85E-09	2.83E-10	8.89E-09	1.43E-08	8.55E-09	2.39E-08	3.05E-08	1.14E-08	1.37E-08
70	6.67E-09	6.89E-09	1.35E-08	7.95E-09	2.59E-10	8.71E-09	1.25E-08	7.50E-09	2.39E-08	3.05E-08	1.14E-08	1.37E-08
71	1.84E-08	6.89E-09	9.50E-09	8.32E-09	6.17E-10	1.51E-09	7.28E-09	5.40E-09	2.39E-08	3.05E-08	1.14E-08	1.37E-08
72	1.96E-08	7.28E-09	1.03E-08	8.69E-09	6.94E-10	1.75E-09	8.06E-09	6.15E-09	2.39E-08	3.05E-08	1.14E-08	1.37E-08
73	1.54E-08	1.25E-08	1.78E-08	1.60E-08	8.21E-10	3.53E-09	1.56E-08	1.10E-08	2.39E-08	3.05E-08	1.14E-08	1.37E-08
74	1.56E-08	6.63E-09	9.30E-09	7.73E-09	5.93E-10	1.53E-09	7.54E-09	5.40E-09	2.39E-08	3.05E-08	1.14E-08	1.37E-08
75	7.13E-09	1.03E-08	1.48E-08	1.24E-08	3.89E-10	5.20E-09	1.72E-08	1.25E-08	2.39E-08	3.05E-08	1.14E-08	1.37E-08
76	2.21E-08	2.25E-08	3.01E-08	3.05E-08	1.24E-09	5.53E-09	2.68E-08	1.94E-08	2.39E-08	3.05E-08	1.14E-08	1.37E-08
77	8.28E-09	7.80E-09	1.11E-08	9.55E-09	4.58E-10	2.36E-09	1.04E-08	7.35E-09	2.39E-08	3.05E-08	1.14E-08	1.37E-08
78	5.13E-08	3.93E-08	5.76E-08	4.01E-08	2.65E-09	6.05E-09	3.77E-08	2.31E-08	2.39E-08	3.05E-08	1.14E-08	1.37E-08

TABLE D (PART 1).—Total Combined Cancer Risk of All Pollutants from All TAs-Continued

NO.	1	2	3	4	5	6	7	8	9	10	11	12
REC.#	CHLF	FORM	TRCE	MECH	Be	MICH	ETDC	CCL4	Ni	BENZ	ACAL	ETAC
	Max. CR	Max. CR	Max. CR	Max. CR	Max. CR	Max. CR	Max. CR	Max. CR	Max. CR	Max. CR	Max. CR	Max. CR
79	1.61E-09	1.56E-09	2.10E-09	1.77E-09	8.16E-11	2.70E-10	2.08E-09	1.35E-09	2.39E-08	3.05E-08	1.14E-08	1.37E-08
80	1.84E-09	1.43E-09	2.00E-09	1.81E-09	9.36E-11	3.06E-10	1.82E-09	1.35E-09	2.39E-08	3.05E-08	1.14E-08	1.37E-08
81	5.75E-09	4.81E-09	5.30E-09	5.77E-09	1.97E-10	5.40E-10	5.20E-09	3.90E-09	2.39E-08	3.05E-08	1.14E-08	1.37E-08
82	9.89E-09	1.11E-08	1.54E-08	1.47E-08	3.98E-10	4.39E-09	1.92E-08	1.44E-08	2.39E-08	3.05E-08	1.14E-08	1.37E-08
83	1.01E-08	1.17E-08	1.67E-08	1.52E-08	3.79E-10	5.09E-09	2.16E-08	1.64E-08	2.39E-08	3.05E-08	1.14E-08	1.37E-08
84	2.44E-08	2.37E-08	3.05E-08	3.53E-08	5.86E-10	9.86E-09	4.76E-08	3.84E-08	2.39E-08	3.05E-08	1.14E-08	1.37E-08
85	1.17E-08	1.17E-08	1.62E-08	1.63E-08	4.70E-10	4.10E-09	1.79E-08	1.37E-08	2.39E-08	3.05E-08	1.14E-08	1.37E-08
86	2.30E-09	2.34E-09	3.40E-09	2.93E-09	1.22E-10	9.36E-10	3.64E-09	2.55E-09	2.39E-08	3.05E-08	1.14E-08	1.37E-08
87	1.75E-08	1.24E-08	1.46E-08	1.67E-08	4.27E-10	9.90E-10	1.33E-08	1.16E-08	2.39E-08	3.05E-08	1.14E-08	1.37E-08
88	1.06E-08	1.57E-08	1.04E-08	1.09E-08	2.28E-10	7.20E-10	1.01E-08	8.55E-09	2.39E-08	3.05E-08	1.14E-08	1.37E-08
89	2.30E-10	1.30E-10	2.00E-10	1.65E-10	9.60E-12	3.60E-11	2.60E-10	1.50E-10	2.39E-08	3.05E-08	1.14E-08	1.37E-08
90	2.30E-10	3.90E-10	5.00E-10	4.23E-10	1.68E-11	1.08E-10	5.20E-10	3.00E-10	2.39E-08	3.05E-08	1.14E-08	1.37E-08
91	2.30E-10	1.30E-10	3.00E-10	2.40E-10	1.20E-11	5.40E-11	2.60E-10	1.50E-10	2.39E-08	3.05E-08	1.14E-08	1.37E-08
92	4.60E-10	5.20E-10	9.00E-10	6.72E-10	2.64E-11	2.16E-10	7.80E-10	4.50E-10	2.39E-08	3.05E-08	1.14E-08	1.37E-08
93	9.20E-10	1.04E-09	1.60E-09	1.27E-09	5.28E-11	5.22E-10	1.56E-09	1.05E-09	2.39E-08	3.05E-08	1.14E-08	1.37E-08
94	2.30E-10	2.60E-10	4.00E-10	3.34E-10	9.60E-12	5.40E-11	5.20E-10	3.00E-10	2.39E-08	3.05E-08	1.14E-08	1.37E-08
95	2.30E-10	3.90E-10	5.00E-10	4.14E-10	9.60E-12	7.20E-11	5.20E-10	3.00E-10	2.39E-08	3.05E-08	1.14E-08	1.37E-08
96	2.30E-10	2.60E-10	4.00E-10	3.34E-10	9.60E-12	7.20E-11	5.20E-10	3.00E-10	2.39E-08	3.05E-08	1.14E-08	1.37E-08
97	4.60E-10	3.90E-10	5.00E-10	4.28E-10	9.60E-12	9.00E-11	5.20E-10	4.50E-10	2.39E-08	3.05E-08	1.14E-08	1.37E-08
98	4.60E-10	3.90E-10	6.00E-10	4.79E-10	1.92E-11	1.08E-10	7.80E-10	4.50E-10	2.39E-08	3.05E-08	1.14E-08	1.37E-08
99	4.60E-10	5.20E-10	9.00E-10	6.77E-10	2.40E-11	1.98E-10	7.80E-10	6.00E-10	2.39E-08	3.05E-08	1.14E-08	1.37E-08
100	6.90E-10	7.80E-10	1.20E-09	9.45E-10	3.12E-11	4.32E-10	1.04E-09	7.50E-10	2.39E-08	3.05E-08	1.14E-08	1.37E-08
101	1.38E-09	1.56E-09	2.50E-09	1.89E-09	6.96E-11	9.54E-10	2.34E-09	1.50E-09	2.39E-08	3.05E-08	1.14E-08	1.37E-08
102	1.38E-09	1.82E-09	2.80E-09	2.18E-09	8.16E-11	7.56E-10	2.60E-09	1.80E-09	2.39E-08	3.05E-08	1.14E-08	1.37E-08
103	1.61E-09	1.69E-09	2.60E-09	2.12E-09	7.92E-11	7.38E-10	2.60E-09	1.80E-09	2.39E-08	3.05E-08	1.14E-08	1.37E-08
104	1.38E-09	1.56E-09	2.10E-09	1.85E-09	7.68E-11	6.48E-10	2.34E-09	1.50E-09	2.39E-08	3.05E-08	1.14E-08	1.37E-08

TABLE D (PART 1).—Total Combined Cancer Risk of All Pollutants from All TAs-Continued

NO.	1		2		3		4		5		6		7		8		9		10		11		12					
	CHLF	FORM	TRCE	MECH	Be	MTCH	ETDC	CCL4	Ni	BENZ	ACAL	ETAC	Max. CR	Max. CR	Max. CR	Max. CR	Max. CR	Max. CR	Max. CR	Max. CR	Max. CR	Max. CR	Max. CR	Max. CR				
105	1.38E-09	1.43E-09	2.10E-09	1.76E-09	7.20E-11	5.22E-10	2.08E-09	1.35E-09	2.39E-08	3.05E-08	1.14E-08	1.37E-08	2.08E-09	1.35E-09	2.39E-08	3.05E-08	1.14E-08	1.37E-08	2.39E-08	3.05E-08	1.14E-08	1.37E-08	2.08E-09	1.35E-09	2.39E-08	3.05E-08	1.14E-08	1.37E-08
106	2.76E-09	3.12E-09	4.40E-09	3.91E-09	1.37E-10	1.17E-09	4.94E-09	3.75E-09	2.39E-08	3.05E-08	1.14E-08	1.37E-08	4.94E-09	3.75E-09	2.39E-08	3.05E-08	1.14E-08	1.37E-08	2.39E-08	3.05E-08	1.14E-08	1.37E-08	4.94E-09	3.75E-09	2.39E-08	3.05E-08	1.14E-08	1.37E-08
107	2.53E-09	2.86E-09	4.20E-09	3.61E-09	1.25E-10	1.15E-09	4.68E-09	3.30E-09	2.39E-08	3.05E-08	1.14E-08	1.37E-08	4.68E-09	3.30E-09	2.39E-08	3.05E-08	1.14E-08	1.37E-08	2.39E-08	3.05E-08	1.14E-08	1.37E-08	4.68E-09	3.30E-09	2.39E-08	3.05E-08	1.14E-08	1.37E-08
108	2.07E-09	2.47E-09	3.50E-09	2.99E-09	1.03E-10	9.90E-10	3.90E-09	2.85E-09	2.39E-08	3.05E-08	1.14E-08	1.37E-08	3.90E-09	2.85E-09	2.39E-08	3.05E-08	1.14E-08	1.37E-08	2.39E-08	3.05E-08	1.14E-08	1.37E-08	3.90E-09	2.85E-09	2.39E-08	3.05E-08	1.14E-08	1.37E-08
109	1.84E-09	2.08E-09	3.00E-09	2.51E-09	8.88E-11	7.92E-10	3.38E-09	2.40E-09	2.39E-08	3.05E-08	1.14E-08	1.37E-08	3.38E-09	2.40E-09	2.39E-08	3.05E-08	1.14E-08	1.37E-08	2.39E-08	3.05E-08	1.14E-08	1.37E-08	3.38E-09	2.40E-09	2.39E-08	3.05E-08	1.14E-08	1.37E-08
110	1.84E-09	2.08E-09	3.20E-09	2.61E-09	9.84E-11	9.18E-10	3.64E-09	2.55E-09	2.39E-08	3.05E-08	1.14E-08	1.37E-08	3.64E-09	2.55E-09	2.39E-08	3.05E-08	1.14E-08	1.37E-08	2.39E-08	3.05E-08	1.14E-08	1.37E-08	3.64E-09	2.55E-09	2.39E-08	3.05E-08	1.14E-08	1.37E-08
111	9.20E-10	9.10E-10	1.40E-09	1.14E-09	4.56E-11	5.04E-10	1.30E-09	9.00E-10	2.39E-08	3.05E-08	1.14E-08	1.37E-08	1.30E-09	9.00E-10	2.39E-08	3.05E-08	1.14E-08	1.37E-08	2.39E-08	3.05E-08	1.14E-08	1.37E-08	1.30E-09	9.00E-10	2.39E-08	3.05E-08	1.14E-08	1.37E-08
112	4.60E-10	5.20E-10	7.00E-10	5.64E-10	2.16E-11	1.98E-10	7.80E-10	6.00E-10	2.39E-08	3.05E-08	1.14E-08	1.37E-08	7.80E-10	6.00E-10	2.39E-08	3.05E-08	1.14E-08	1.37E-08	2.39E-08	3.05E-08	1.14E-08	1.37E-08	7.80E-10	6.00E-10	2.39E-08	3.05E-08	1.14E-08	1.37E-08
113	9.20E-10	7.80E-10	1.20E-09	1.02E-09	4.32E-11	3.24E-10	1.30E-09	7.50E-10	2.39E-08	3.05E-08	1.14E-08	1.37E-08	1.30E-09	7.50E-10	2.39E-08	3.05E-08	1.14E-08	1.37E-08	2.39E-08	3.05E-08	1.14E-08	1.37E-08	1.30E-09	7.50E-10	2.39E-08	3.05E-08	1.14E-08	1.37E-08
114	4.60E-10	3.90E-10	6.00E-10	4.98E-10	2.16E-11	1.80E-10	5.20E-10	4.50E-10	2.39E-08	3.05E-08	1.14E-08	1.37E-08	5.20E-10	4.50E-10	2.39E-08	3.05E-08	1.14E-08	1.37E-08	2.39E-08	3.05E-08	1.14E-08	1.37E-08	5.20E-10	4.50E-10	2.39E-08	3.05E-08	1.14E-08	1.37E-08
115	4.60E-10	5.20E-10	8.00E-10	6.11E-10	2.40E-11	1.80E-10	7.80E-10	6.00E-10	2.39E-08	3.05E-08	1.14E-08	1.37E-08	7.80E-10	6.00E-10	2.39E-08	3.05E-08	1.14E-08	1.37E-08	2.39E-08	3.05E-08	1.14E-08	1.37E-08	7.80E-10	6.00E-10	2.39E-08	3.05E-08	1.14E-08	1.37E-08
116	2.30E-10	2.60E-10	4.00E-10	3.34E-10	1.20E-11	1.08E-10	5.20E-10	3.00E-10	2.39E-08	3.05E-08	1.14E-08	1.37E-08	5.20E-10	3.00E-10	2.39E-08	3.05E-08	1.14E-08	1.37E-08	2.39E-08	3.05E-08	1.14E-08	1.37E-08	5.20E-10	3.00E-10	2.39E-08	3.05E-08	1.14E-08	1.37E-08
117	4.60E-10	5.20E-10	7.00E-10	5.55E-10	2.16E-11	1.80E-10	5.20E-10	4.50E-10	2.39E-08	3.05E-08	1.14E-08	1.37E-08	5.20E-10	4.50E-10	2.39E-08	3.05E-08	1.14E-08	1.37E-08	2.39E-08	3.05E-08	1.14E-08	1.37E-08	5.20E-10	4.50E-10	2.39E-08	3.05E-08	1.14E-08	1.37E-08
118	1.61E-09	1.82E-09	2.80E-09	2.24E-09	8.40E-11	7.20E-10	3.38E-09	2.10E-09	2.39E-08	3.05E-08	1.14E-08	1.37E-08	3.38E-09	2.10E-09	2.39E-08	3.05E-08	1.14E-08	1.37E-08	2.39E-08	3.05E-08	1.14E-08	1.37E-08	3.38E-09	2.10E-09	2.39E-08	3.05E-08	1.14E-08	1.37E-08
119	1.61E-09	1.82E-09	2.80E-09	2.17E-09	7.92E-11	9.18E-10	3.12E-09	2.10E-09	2.39E-08	3.05E-08	1.14E-08	1.37E-08	3.12E-09	2.10E-09	2.39E-08	3.05E-08	1.14E-08	1.37E-08	2.39E-08	3.05E-08	1.14E-08	1.37E-08	3.12E-09	2.10E-09	2.39E-08	3.05E-08	1.14E-08	1.37E-08
120	1.61E-09	1.82E-09	2.70E-09	2.23E-09	8.88E-11	6.66E-10	2.60E-09	1.80E-09	2.39E-08	3.05E-08	1.14E-08	1.37E-08	2.60E-09	1.80E-09	2.39E-08	3.05E-08	1.14E-08	1.37E-08	2.39E-08	3.05E-08	1.14E-08	1.37E-08	2.60E-09	1.80E-09	2.39E-08	3.05E-08	1.14E-08	1.37E-08
121	2.30E-10	3.90E-10	5.00E-10	3.95E-10	1.44E-11	1.44E-10	5.20E-10	3.00E-10	2.39E-08	3.05E-08	1.14E-08	1.37E-08	5.20E-10	3.00E-10	2.39E-08	3.05E-08	1.14E-08	1.37E-08	2.39E-08	3.05E-08	1.14E-08	1.37E-08	5.20E-10	3.00E-10	2.39E-08	3.05E-08	1.14E-08	1.37E-08
122	3.22E-09	3.64E-09	5.30E-09	4.54E-09	1.56E-10	1.44E-09	5.98E-09	4.35E-09	2.39E-08	3.05E-08	1.14E-08	1.37E-08	5.98E-09	4.35E-09	2.39E-08	3.05E-08	1.14E-08	1.37E-08	2.39E-08	3.05E-08	1.14E-08	1.37E-08	5.98E-09	4.35E-09	2.39E-08	3.05E-08	1.14E-08	1.37E-08
123	1.15E-09	1.17E-09	1.90E-09	1.44E-09	3.84E-11	2.70E-10	2.08E-09	1.20E-09	2.39E-08	3.05E-08	1.14E-08	1.37E-08	2.08E-09	1.20E-09	2.39E-08	3.05E-08	1.14E-08	1.37E-08	2.39E-08	3.05E-08	1.14E-08	1.37E-08	2.08E-09	1.20E-09	2.39E-08	3.05E-08	1.14E-08	1.37E-08
124	4.60E-10	5.20E-10	8.00E-10	6.44E-10	1.92E-11	1.26E-10	7.80E-10	6.00E-10	2.39E-08	3.05E-08	1.14E-08	1.37E-08	7.80E-10	6.00E-10	2.39E-08	3.05E-08	1.14E-08	1.37E-08	2.39E-08	3.05E-08	1.14E-08	1.37E-08	7.80E-10	6.00E-10	2.39E-08	3.05E-08	1.14E-08	1.37E-08
125	2.30E-10	2.60E-10	5.00E-10	3.90E-10	1.20E-11	7.20E-11	5.20E-10	3.00E-10	2.39E-08	3.05E-08	1.14E-08	1.37E-08	5.20E-10	3.00E-10	2.39E-08	3.05E-08	1.14E-08	1.37E-08	2.39E-08	3.05E-08	1.14E-08	1.37E-08	5.20E-10	3.00E-10	2.39E-08	3.05E-08	1.14E-08	1.37E-08
126	2.30E-10	2.60E-10	3.00E-10	2.49E-10	9.60E-12	7.20E-11	2.60E-10	1.50E-10	2.39E-08	3.05E-08	1.14E-08	1.37E-08	2.60E-10	1.50E-10	2.39E-08	3.05E-08	1.14E-08	1.37E-08	2.39E-08	3.05E-08	1.14E-08	1.37E-08	2.60E-10	1.50E-10	2.39E-08	3.05E-08	1.14E-08	1.37E-08
127	2.30E-10	2.60E-10	4.00E-10	3.29E-10	9.60E-12	5.40E-11	2.60E-10	3.00E-10	2.39E-08	3.05E-08	1.14E-08	1.37E-08	2.60E-10	3.00E-10	2.39E-08	3.05E-08	1.14E-08	1.37E-08	2.39E-08	3.05E-08	1.14E-08	1.37E-08	2.60E-10	3.00E-10	2.39E-08	3.05E-08	1.14E-08	1.37E-08
128	4.60E-10	6.50E-10	9.00E-10	7.33E-10	2.16E-11	1.08E-10	1.04E-09	6.00E-10	2.39E-08	3.05E-08	1.14E-08	1.37E-08	1.04E-09	6.00E-10	2.39E-08	3.05E-08	1.14E-08	1.37E-08	2.39E-08	3.05E-08	1.14E-08	1.37E-08	1.04E-09	6.00E-10	2.39E-08	3.05E-08	1.14E-08	1.37E-08
129	2.30E-10	2.60E-10	5.00E-10	3.81E-10	9.60E-12	7.20E-11	5.20E-10	3.00E-10	2.39E-08	3.05E-08	1.14E-08	1.37E-08	5.20E-10	3.00E-10	2.39E-08	3.05E-08	1.14E-08	1.37E-08	2.39E-08	3.05E-08	1.14E-08	1.37E-08	5.20E-10	3.00E-10	2.39E-08	3.05E-08	1.14E-08	1.37E-08
130	2.30E-10	2.60E-10	4.00E-10	3.06E-10	1.20E-11	1.08E-10	2.60E-10	3.00E-10	2.39E-08	3.05E-08	1.14E-08	1.37E-08	2.60E-10	3.00E-10	2.39E-08	3.05E-08	1.14E-08	1.37E-08	2.39E-08	3.05E-08	1.14E-08	1.37E-08	2.60E-10	3.00E-10	2.39E-08	3.05E-08	1.14E-08	1.37E-08

TABLE D (PART 1).—Total Combined Cancer Risk of All Pollutants from All TAs—Continued

NO.	1	2	3	4	5	6	7	8	9	10	11	12
REC. #	CHLF	FORM	TRCE	MECH	Be	MTCB	ETDC	CCL4	Ni	BENZ	ACAL	ETAC
	Max. CR	Max. CR	Max. CR	Max. CR	Max. CR	Max. CR	Max. CR	Max. CR	Max. CR	Max. CR	Max. CR	Max. CR
131	0.00E+00	1.30E-10	1.00E-10	8.46E-11	2.40E-12	3.60E-11	0.00E+00	0.00E+00	2.39E-08	3.05E-08	1.14E-08	1.37E-08
132	0.00E+00	1.30E-10	2.00E-10	1.27E-10	2.40E-12	1.80E-11	2.60E-10	1.50E-10	2.39E-08	3.05E-08	1.14E-08	1.37E-08
133	2.30E-10	2.60E-10	3.00E-10	2.44E-10	4.80E-12	5.40E-11	2.60E-10	1.50E-10	2.39E-08	3.05E-08	1.14E-08	1.37E-08
134	0.00E+00	1.30E-10	1.00E-10	8.93E-11	2.40E-12	1.80E-11	0.00E+00	0.00E+00	2.39E-08	3.05E-08	1.14E-08	1.37E-08
135	2.30E-10	3.90E-10	5.00E-10	4.75E-10	1.44E-11	1.08E-10	5.20E-10	3.00E-10	2.39E-08	3.05E-08	1.14E-08	1.37E-08
136	1.15E-09	1.30E-09	2.10E-09	1.60E-09	5.04E-11	4.14E-10	2.34E-09	1.50E-09	2.39E-08	3.05E-08	1.14E-08	1.37E-08
137	2.30E-10	2.60E-10	5.00E-10	3.85E-10	1.68E-11	9.00E-11	5.20E-10	3.00E-10	2.39E-08	3.05E-08	1.14E-08	1.37E-08
138	7.59E-09	1.11E-08	1.57E-08	1.32E-08	4.15E-10	5.17E-09	1.87E-08	1.38E-08	2.39E-08	3.05E-08	1.14E-08	1.37E-08
139	2.30E-10	2.60E-10	3.00E-10	2.44E-10	7.20E-12	5.40E-11	2.60E-10	3.00E-10	2.39E-08	3.05E-08	1.14E-08	1.37E-08
140	2.30E-10	2.60E-10	4.00E-10	3.29E-10	9.60E-12	5.40E-11	5.20E-10	3.00E-10	2.39E-08	3.05E-08	1.14E-08	1.37E-08
141	4.60E-10	3.90E-10	7.00E-10	5.45E-10	1.44E-11	1.08E-10	7.80E-10	4.50E-10	2.39E-08	3.05E-08	1.14E-08	1.37E-08
142	4.83E-09	5.59E-09	1.05E-08	6.77E-09	2.04E-10	2.20E-09	1.07E-08	6.45E-09	2.39E-08	3.05E-08	1.14E-08	1.37E-08
143	6.90E-10	7.80E-10	1.30E-09	9.64E-10	3.12E-11	2.34E-10	1.30E-09	9.00E-10	2.39E-08	3.05E-08	1.14E-08	1.37E-08
144	0.00E+00	1.30E-10	1.00E-10	8.46E-11	2.40E-12	1.80E-11	0.00E+00	0.00E+00	2.39E-08	3.05E-08	1.14E-08	1.37E-08
145	2.30E-10	2.60E-10	4.00E-10	2.91E-10	9.60E-12	9.00E-11	2.60E-10	1.50E-10	2.39E-08	3.05E-08	1.14E-08	1.37E-08
146	2.30E-10	2.60E-10	4.00E-10	3.62E-10	1.44E-11	9.00E-11	5.20E-10	3.00E-10	2.39E-08	3.05E-08	1.14E-08	1.37E-08
147	7.13E-09	9.10E-09	1.31E-08	1.14E-08	3.38E-10	4.39E-09	1.59E-08	1.14E-08	2.39E-08	3.05E-08	1.14E-08	1.37E-08
148	7.36E-09	1.09E-08	1.66E-08	1.28E-08	4.13E-10	6.19E-09	1.85E-08	1.40E-08	2.39E-08	3.05E-08	1.14E-08	1.37E-08
149	6.67E-09	8.45E-09	1.37E-08	9.72E-09	3.31E-10	5.92E-09	1.38E-08	9.15E-09	2.39E-08	3.05E-08	1.14E-08	1.37E-08
150	7.82E-09	8.45E-09	1.61E-08	9.72E-09	3.10E-10	1.03E-08	1.56E-08	9.60E-09	2.39E-08	3.05E-08	1.14E-08	1.37E-08
151	9.89E-09	9.23E-09	1.95E-08	1.14E-08	3.00E-10	1.43E-08	1.79E-08	1.05E-08	2.39E-08	3.05E-08	1.14E-08	1.37E-08
152	1.59E-08	7.67E-09	2.17E-08	9.11E-09	2.45E-10	3.99E-08	1.25E-08	7.80E-09	2.39E-08	3.05E-08	1.14E-08	1.37E-08
153	5.98E-09	6.37E-09	1.10E-08	7.75E-09	2.28E-10	3.42E-09	1.20E-08	7.20E-09	2.39E-08	3.05E-08	1.14E-08	1.37E-08
154	6.44E-09	7.93E-09	1.38E-08	9.42E-09	2.47E-10	2.39E-09	1.46E-08	8.55E-09	2.39E-08	3.05E-08	1.14E-08	1.37E-08
155	5.52E-09	6.63E-09	1.19E-08	7.91E-09	2.09E-10	2.30E-09	1.17E-08	7.05E-09	2.39E-08	3.05E-08	1.14E-08	1.37E-08
156	5.75E-09	6.89E-09	1.16E-08	7.84E-09	2.06E-10	1.57E-09	1.20E-08	6.45E-09	2.39E-08	3.05E-08	1.14E-08	1.37E-08

TABLE D (PART 1).—Total Combined Cancer Risk of All Pollutants from All TAs-Continued

NO.	1	2	3	4	5	6	7	8	9	10	11	12
REC.#	CHLF	FORM	TRCE	MECH	Be	MTCH	ETDC	CCL4	Ni	BENZ	ACAL	ETAC
	Max. CR	Max. CR	Max. CR	Max. CR	Max. CR	Max. CR	Max. CR	Max. CR	Max. CR	Max. CR	Max. CR	Max. CR
157	6.44E-09	7.15E-09	1.24E-08	8.24E-09	2.38E-10	1.51E-09	1.27E-08	6.45E-09	2.39E-08	3.05E-08	1.14E-08	1.37E-08
158	7.82E-09	8.84E-09	1.74E-08	1.02E-08	2.86E-10	1.62E-09	1.77E-08	7.95E-09	2.39E-08	3.05E-08	1.14E-08	1.37E-08
159	8.97E-09	9.49E-09	1.73E-08	1.06E-08	2.93E-10	1.17E-09	1.69E-08	7.35E-09	2.39E-08	3.05E-08	1.14E-08	1.37E-08
160	8.05E-09	8.45E-09	1.31E-08	1.01E-08	2.45E-10	1.06E-09	1.17E-08	6.00E-09	2.39E-08	3.05E-08	1.14E-08	1.37E-08
161	1.22E-08	1.12E-08	1.86E-08	1.32E-08	2.83E-10	1.22E-09	1.72E-08	7.80E-09	2.39E-08	3.05E-08	1.14E-08	1.37E-08
162	1.31E-08	1.31E-08	1.58E-08	1.57E-08	3.00E-10	1.10E-09	1.56E-08	7.95E-09	2.39E-08	3.05E-08	1.14E-08	1.37E-08
163	1.59E-08	1.57E-08	1.61E-08	1.95E-08	3.07E-10	8.64E-10	1.46E-08	8.55E-09	2.39E-08	3.05E-08	1.14E-08	1.37E-08
164	5.06E-09	4.42E-09	5.40E-09	5.10E-09	1.22E-10	5.04E-10	5.46E-09	3.75E-09	2.39E-08	3.05E-08	1.14E-08	1.37E-08
165	4.37E-09	4.55E-09	5.90E-09	5.76E-09	1.37E-10	5.76E-10	4.68E-09	3.30E-09	2.39E-08	3.05E-08	1.14E-08	1.37E-08
166	5.06E-09	5.46E-09	7.00E-09	6.68E-09	1.46E-10	5.58E-10	5.20E-09	3.90E-09	2.39E-08	3.05E-08	1.14E-08	1.37E-08
167	5.98E-09	5.46E-09	6.30E-09	6.13E-09	1.94E-10	6.12E-10	6.24E-09	4.80E-09	2.39E-08	3.05E-08	1.14E-08	1.37E-08
168	1.79E-08	9.36E-09	1.20E-08	1.24E-08	3.91E-10	1.15E-09	1.09E-08	8.85E-09	2.39E-08	3.05E-08	1.14E-08	1.37E-08
169	4.58E-08	1.56E-08	2.32E-08	2.70E-08	1.64E-09	4.57E-09	1.64E-08	1.13E-08	2.39E-08	3.05E-08	1.14E-08	1.37E-08
170	2.53E-08	1.70E-08	2.28E-08	2.21E-08	1.15E-09	4.07E-09	1.77E-08	1.20E-08	2.39E-08	3.05E-08	1.14E-08	1.37E-08
171	1.91E-08	1.82E-08	2.47E-08	2.45E-08	1.01E-09	5.22E-09	2.39E-08	1.71E-08	2.39E-08	3.05E-08	1.14E-08	1.37E-08
172	1.84E-08	2.04E-08	2.55E-08	2.49E-08	8.50E-10	5.94E-09	2.47E-08	2.00E-08	2.39E-08	3.05E-08	1.14E-08	1.37E-08
173	1.66E-08	1.85E-08	2.36E-08	2.38E-08	7.13E-10	5.71E-09	2.55E-08	2.00E-08	2.39E-08	3.05E-08	1.14E-08	1.37E-08
174	1.61E-08	1.48E-08	1.99E-08	2.11E-08	5.76E-10	5.20E-09	2.52E-08	2.01E-08	2.39E-08	3.05E-08	1.14E-08	1.37E-08
175	8.74E-07	5.17E-08	6.73E-08	1.94E-08	1.71E-09	8.08E-09	1.38E-08	1.08E-08	3.06E-09	7.22E-09	9.50E-09	8.53E-09
176	6.90E-07	4.34E-08	5.94E-08	2.02E-08	1.91E-09	1.18E-08	1.43E-08	1.14E-08	3.14E-09	7.47E-09	9.46E-09	8.82E-09
177	5.65E-07	3.76E-08	4.93E-08	1.97E-08	1.89E-09	1.12E-08	1.40E-08	1.11E-08	3.07E-09	7.39E-09	9.09E-09	8.37E-09
178	5.96E-07	3.94E-08	4.93E-08	1.97E-08	1.71E-09	8.96E-09	1.40E-08	1.11E-08	3.11E-09	7.39E-09	9.79E-09	8.65E-09
179	4.51E-07	3.28E-08	4.33E-08	2.05E-08	1.98E-09	1.36E-08	1.46E-08	1.17E-08	3.19E-09	7.64E-09	9.48E-09	9.31E-09
180	7.71E-07	4.80E-08	5.39E-08	2.13E-08	1.80E-09	1.01E-08	1.46E-08	1.16E-08	3.26E-09	7.72E-09	1.12E-08	9.87E-09

TABLE D (PART 2).—Total Combined Cancer Risk of All Pollutants from All TAs

NO.	13	14	15	16	17	18	19	20	21	22	23	24
REC. #	TECE	PRDI	STYR	CDDF	As	Cd	BNZP	Cr Vi	ACAM	1,3-BUT	2-NTP	1,1,1,2-TCE
	Max. CR	Max. CR	Max. CR	Max. CR	Max. CR	Max. CR	Max. CR	Max. CR	Max. CR	Max. CR	Max. CR	Max. CR
1	1.97E-08	1.13E-08	1.97E-08	5.61E-10	1.22E-08	2.86E-08	2.89E-10	1.00E-08	2.02E-08	8.40E-09	1.08E-07	9.77E-09
2	1.97E-08	1.13E-08	1.97E-08	5.61E-10	1.22E-08	2.86E-08	2.89E-10	1.00E-08	2.02E-08	8.40E-09	1.08E-07	9.77E-09
3	1.97E-08	1.13E-08	1.97E-08	5.61E-10	1.22E-08	2.86E-08	2.89E-10	1.00E-08	2.02E-08	8.40E-09	1.08E-07	9.77E-09
4	1.97E-08	1.13E-08	1.97E-08	5.61E-10	1.22E-08	2.86E-08	2.89E-10	1.00E-08	2.02E-08	8.40E-09	1.08E-07	9.77E-09
5	1.97E-08	1.13E-08	1.97E-08	5.61E-10	1.22E-08	2.86E-08	2.89E-10	1.00E-08	2.02E-08	8.40E-09	1.08E-07	9.77E-09
6	1.97E-08	1.13E-08	1.97E-08	5.61E-10	1.22E-08	2.86E-08	2.89E-10	1.00E-08	2.02E-08	8.40E-09	1.08E-07	9.77E-09
7	1.97E-08	1.13E-08	1.97E-08	5.61E-10	1.22E-08	2.86E-08	2.89E-10	1.00E-08	2.02E-08	8.40E-09	1.08E-07	9.77E-09
8	1.97E-08	1.13E-08	1.97E-08	5.61E-10	1.22E-08	2.86E-08	2.89E-10	1.00E-08	2.02E-08	8.40E-09	1.08E-07	9.77E-09
9	1.97E-08	1.13E-08	1.97E-08	5.61E-10	1.22E-08	2.86E-08	2.89E-10	1.00E-08	2.02E-08	8.40E-09	1.08E-07	9.77E-09
10	1.97E-08	1.13E-08	1.97E-08	5.61E-10	1.22E-08	2.86E-08	2.89E-10	1.00E-08	2.02E-08	8.40E-09	1.08E-07	9.77E-09
11	1.97E-08	1.13E-08	1.97E-08	5.61E-10	1.22E-08	2.86E-08	2.89E-10	1.00E-08	2.02E-08	8.40E-09	1.08E-07	9.77E-09
12	1.97E-08	1.13E-08	1.97E-08	5.61E-10	1.22E-08	2.86E-08	2.89E-10	1.00E-08	2.02E-08	8.40E-09	1.08E-07	9.77E-09
13	1.97E-08	1.13E-08	1.97E-08	5.61E-10	1.22E-08	2.86E-08	2.89E-10	1.00E-08	2.02E-08	8.40E-09	1.08E-07	9.77E-09
14	1.97E-08	1.13E-08	1.97E-08	5.61E-10	1.22E-08	2.86E-08	2.89E-10	1.00E-08	2.02E-08	8.40E-09	1.08E-07	9.77E-09
15	1.97E-08	1.13E-08	1.97E-08	5.61E-10	1.22E-08	2.86E-08	2.89E-10	1.00E-08	2.02E-08	8.40E-09	1.08E-07	9.77E-09
16	1.97E-08	1.13E-08	1.97E-08	5.61E-10	1.22E-08	2.86E-08	2.89E-10	1.00E-08	2.02E-08	8.40E-09	1.08E-07	9.77E-09
17	1.97E-08	1.13E-08	1.97E-08	5.61E-10	1.22E-08	2.86E-08	2.89E-10	1.00E-08	2.02E-08	8.40E-09	1.08E-07	9.77E-09
18	1.97E-08	1.13E-08	1.97E-08	5.61E-10	1.22E-08	2.86E-08	2.89E-10	1.00E-08	2.02E-08	8.40E-09	1.08E-07	9.77E-09
19	1.97E-08	1.13E-08	1.97E-08	5.61E-10	1.22E-08	2.86E-08	2.89E-10	1.00E-08	2.02E-08	8.40E-09	1.08E-07	9.77E-09
20	1.97E-08	1.13E-08	1.97E-08	5.61E-10	1.22E-08	2.86E-08	2.89E-10	1.00E-08	2.02E-08	8.40E-09	1.08E-07	9.77E-09
21	1.97E-08	1.13E-08	1.97E-08	5.61E-10	1.22E-08	2.86E-08	2.89E-10	1.00E-08	2.02E-08	8.40E-09	1.08E-07	9.77E-09
22	1.97E-08	1.13E-08	1.97E-08	5.61E-10	1.22E-08	2.86E-08	2.89E-10	1.00E-08	2.02E-08	8.40E-09	1.08E-07	9.77E-09
23	1.97E-08	1.13E-08	1.97E-08	5.61E-10	1.22E-08	2.86E-08	2.89E-10	1.00E-08	2.02E-08	8.40E-09	1.08E-07	9.77E-09
24	1.97E-08	1.13E-08	1.97E-08	5.61E-10	1.22E-08	2.86E-08	2.89E-10	1.00E-08	2.02E-08	8.40E-09	1.08E-07	9.77E-09
25	1.97E-08	1.13E-08	1.97E-08	5.61E-10	1.22E-08	2.86E-08	2.89E-10	1.00E-08	2.02E-08	8.40E-09	1.08E-07	9.77E-09
26	1.97E-08	1.13E-08	1.97E-08	5.61E-10	1.22E-08	2.86E-08	2.89E-10	1.00E-08	2.02E-08	8.40E-09	1.08E-07	9.77E-09

TABLE D (PART 2).—Total Combined Cancer Risk of All Pollutants from All TAs-Continued

NO.	13	14	15	16	17	18	19	20	21	22	23	24
REC.#	TECE Max. CR	PRDI Max. CR	STYR Max. CR	CDDF Max. CR	As Max. CR	Cd Max. CR	BNZP Max. CR	Cr Vi Max. CR	ACAM Max. CR	1,3-BUT Max. CR	2-NTP Max. CR	1,1,1,2-TCE Max. CR
27	1.97E-08	1.13E-08	1.97E-08	5.61E-10	1.22E-08	2.86E-08	2.89E-10	1.00E-08	2.02E-08	8.40E-09	1.08E-07	9.77E-09
28	1.11E-08	1.01E-08	1.10E-08	3.30E-11	1.08E-08	4.04E-09	1.70E-10	1.28E-09	1.16E-08	0.00E+00	0.00E+00	5.18E-10
29	1.97E-08	1.13E-08	1.97E-08	5.61E-10	1.22E-08	2.86E-08	2.89E-10	1.00E-08	2.02E-08	8.40E-09	1.08E-07	9.77E-09
30	1.97E-08	1.13E-08	1.97E-08	5.61E-10	1.22E-08	2.86E-08	2.89E-10	1.00E-08	2.02E-08	8.40E-09	1.08E-07	9.77E-09
31	1.97E-08	1.13E-08	1.97E-08	5.61E-10	1.22E-08	2.86E-08	2.89E-10	1.00E-08	2.02E-08	8.40E-09	1.08E-07	9.77E-09
32	1.97E-08	1.13E-08	1.97E-08	5.61E-10	1.22E-08	2.86E-08	2.89E-10	1.00E-08	2.02E-08	8.40E-09	1.08E-07	9.77E-09
33	1.97E-08	1.13E-08	1.97E-08	5.61E-10	1.22E-08	2.86E-08	2.89E-10	1.00E-08	2.02E-08	8.40E-09	1.08E-07	9.77E-09
34	1.97E-08	1.13E-08	1.97E-08	5.61E-10	1.22E-08	2.86E-08	2.89E-10	1.00E-08	2.02E-08	8.40E-09	1.08E-07	9.77E-09
35	1.97E-08	1.13E-08	1.97E-08	5.61E-10	1.22E-08	2.86E-08	2.89E-10	1.00E-08	2.02E-08	8.40E-09	1.08E-07	9.77E-09
36	1.97E-08	1.13E-08	1.97E-08	5.61E-10	1.22E-08	2.86E-08	2.89E-10	1.00E-08	2.02E-08	8.40E-09	1.08E-07	9.77E-09
37	1.97E-08	1.13E-08	1.97E-08	5.61E-10	1.22E-08	2.86E-08	2.89E-10	1.00E-08	2.02E-08	8.40E-09	1.08E-07	9.77E-09
38	1.97E-08	1.13E-08	1.97E-08	5.61E-10	1.22E-08	2.86E-08	2.89E-10	1.00E-08	2.02E-08	8.40E-09	1.08E-07	9.77E-09
39	1.97E-08	1.13E-08	1.97E-08	5.61E-10	1.22E-08	2.86E-08	2.89E-10	1.00E-08	2.02E-08	8.40E-09	1.08E-07	9.77E-09
40	1.97E-08	1.13E-08	1.97E-08	5.61E-10	1.22E-08	2.86E-08	2.89E-10	1.00E-08	2.02E-08	8.40E-09	1.08E-07	9.77E-09
41	1.97E-08	1.13E-08	1.97E-08	5.61E-10	1.22E-08	2.86E-08	2.89E-10	1.00E-08	2.02E-08	8.40E-09	1.08E-07	9.77E-09
42	1.97E-08	1.13E-08	1.97E-08	5.61E-10	1.22E-08	2.86E-08	2.89E-10	1.00E-08	2.02E-08	8.40E-09	1.08E-07	9.77E-09
43	1.97E-08	1.13E-08	1.97E-08	5.61E-10	1.22E-08	2.86E-08	2.89E-10	1.00E-08	2.02E-08	8.40E-09	1.08E-07	9.77E-09
44	1.97E-08	1.13E-08	1.97E-08	5.61E-10	1.22E-08	2.86E-08	2.89E-10	1.00E-08	2.02E-08	8.40E-09	1.08E-07	9.77E-09
45	1.97E-08	1.13E-08	1.97E-08	5.61E-10	1.22E-08	2.86E-08	2.89E-10	1.00E-08	2.02E-08	8.40E-09	1.08E-07	9.77E-09
46	1.97E-08	1.13E-08	1.97E-08	5.61E-10	1.22E-08	2.86E-08	2.89E-10	1.00E-08	2.02E-08	8.40E-09	1.08E-07	9.77E-09
47	1.97E-08	1.13E-08	1.97E-08	5.61E-10	1.22E-08	2.86E-08	2.89E-10	1.00E-08	2.02E-08	8.40E-09	1.08E-07	9.77E-09
48	1.97E-08	1.13E-08	1.97E-08	5.61E-10	1.22E-08	2.86E-08	2.89E-10	1.00E-08	2.02E-08	8.40E-09	1.08E-07	9.77E-09
49	1.97E-08	1.13E-08	1.97E-08	5.61E-10	1.22E-08	2.86E-08	2.89E-10	1.00E-08	2.02E-08	8.40E-09	1.08E-07	9.77E-09
50	1.97E-08	1.13E-08	1.97E-08	5.61E-10	1.22E-08	2.86E-08	2.89E-10	1.00E-08	2.02E-08	8.40E-09	1.08E-07	9.77E-09
51	1.97E-08	1.13E-08	1.97E-08	5.61E-10	1.22E-08	2.86E-08	2.89E-10	1.00E-08	2.02E-08	8.40E-09	1.08E-07	9.77E-09
52	1.97E-08	1.13E-08	1.97E-08	5.61E-10	1.22E-08	2.86E-08	2.89E-10	1.00E-08	2.02E-08	8.40E-09	1.08E-07	9.77E-09

TABLE D (PART 2).—Total Combined Cancer Risk of All Pollutants from All TAs-Continued

NO.	13	14	15	16	17	18	19	20	21	22	23	24
REC. #	TECE Max. CR	PRDI Max. CR	STYR Max. CR	CDDF Max. CR	As Max. CR	Cd Max. CR	BNZP Max. CR	Cr Vi Max. CR	ACAM Max. CR	1,3-BUT Max. CR	2-NTP Max. CR	1,1,1,2-TCE Max. CR
53	1.97E-08	1.13E-08	1.97E-08	5.61E-10	1.22E-08	2.86E-08	2.89E-10	1.00E-08	2.02E-08	8.40E-09	1.08E-07	9.77E-09
54	1.97E-08	1.13E-08	1.97E-08	5.61E-10	1.22E-08	2.86E-08	2.89E-10	1.00E-08	2.02E-08	8.40E-09	1.08E-07	9.77E-09
55	1.97E-08	1.13E-08	1.97E-08	5.61E-10	1.22E-08	2.86E-08	2.89E-10	1.00E-08	2.02E-08	8.40E-09	1.08E-07	9.77E-09
56	1.97E-08	1.13E-08	1.97E-08	5.61E-10	1.22E-08	2.86E-08	2.89E-10	1.00E-08	2.02E-08	8.40E-09	1.08E-07	9.77E-09
57	1.97E-08	1.13E-08	1.97E-08	5.61E-10	1.22E-08	2.86E-08	2.89E-10	1.00E-08	2.02E-08	8.40E-09	1.08E-07	9.77E-09
58	1.97E-08	1.13E-08	1.97E-08	5.61E-10	1.22E-08	2.86E-08	2.89E-10	1.00E-08	2.02E-08	8.40E-09	1.08E-07	9.77E-09
59	1.97E-08	1.13E-08	1.97E-08	5.61E-10	1.22E-08	2.86E-08	2.89E-10	1.00E-08	2.02E-08	8.40E-09	1.08E-07	9.77E-09
60	1.97E-08	1.13E-08	1.97E-08	5.61E-10	1.22E-08	2.86E-08	2.89E-10	1.00E-08	2.02E-08	8.40E-09	1.08E-07	9.77E-09
61	1.97E-08	1.13E-08	1.97E-08	5.61E-10	1.22E-08	2.86E-08	2.89E-10	1.00E-08	2.02E-08	8.40E-09	1.08E-07	9.77E-09
62	1.97E-08	1.13E-08	1.97E-08	5.61E-10	1.22E-08	2.86E-08	2.89E-10	1.00E-08	2.02E-08	8.40E-09	1.08E-07	9.77E-09
63	1.97E-08	1.13E-08	1.97E-08	5.61E-10	1.22E-08	2.86E-08	2.89E-10	1.00E-08	2.02E-08	8.40E-09	1.08E-07	9.77E-09
64	1.97E-08	1.13E-08	1.97E-08	5.61E-10	1.22E-08	2.86E-08	2.89E-10	1.00E-08	2.02E-08	8.40E-09	1.08E-07	9.77E-09
65	1.97E-08	1.13E-08	1.97E-08	5.61E-10	1.22E-08	2.86E-08	2.89E-10	1.00E-08	2.02E-08	8.40E-09	1.08E-07	9.77E-09
66	1.97E-08	1.13E-08	1.97E-08	5.61E-10	1.22E-08	2.86E-08	2.89E-10	1.00E-08	2.02E-08	8.40E-09	1.08E-07	9.77E-09
67	1.97E-08	1.13E-08	1.97E-08	5.61E-10	1.22E-08	2.86E-08	2.89E-10	1.00E-08	2.02E-08	8.40E-09	1.08E-07	9.77E-09
68	1.97E-08	1.13E-08	1.97E-08	5.61E-10	1.22E-08	2.86E-08	2.89E-10	1.00E-08	2.02E-08	8.40E-09	1.08E-07	9.77E-09
69	1.97E-08	1.13E-08	1.97E-08	5.61E-10	1.22E-08	2.86E-08	2.89E-10	1.00E-08	2.02E-08	8.40E-09	1.08E-07	9.77E-09
70	1.97E-08	1.13E-08	1.97E-08	5.61E-10	1.22E-08	2.86E-08	2.89E-10	1.00E-08	2.02E-08	8.40E-09	1.08E-07	9.77E-09
71	1.97E-08	1.13E-08	1.97E-08	5.61E-10	1.22E-08	2.86E-08	2.89E-10	1.00E-08	2.02E-08	8.40E-09	1.08E-07	9.77E-09
72	1.97E-08	1.13E-08	1.97E-08	5.61E-10	1.22E-08	2.86E-08	2.89E-10	1.00E-08	2.02E-08	8.40E-09	1.08E-07	9.77E-09
73	1.97E-08	1.13E-08	1.97E-08	5.61E-10	1.22E-08	2.86E-08	2.89E-10	1.00E-08	2.02E-08	8.40E-09	1.08E-07	9.77E-09
74	1.97E-08	1.13E-08	1.97E-08	5.61E-10	1.22E-08	2.86E-08	2.89E-10	1.00E-08	2.02E-08	8.40E-09	1.08E-07	9.77E-09
75	1.97E-08	1.13E-08	1.97E-08	5.61E-10	1.22E-08	2.86E-08	2.89E-10	1.00E-08	2.02E-08	8.40E-09	1.08E-07	9.77E-09
76	1.97E-08	1.13E-08	1.97E-08	5.61E-10	1.22E-08	2.86E-08	2.89E-10	1.00E-08	2.02E-08	8.40E-09	1.08E-07	9.77E-09
77	1.97E-08	1.13E-08	1.97E-08	5.61E-10	1.22E-08	2.86E-08	2.89E-10	1.00E-08	2.02E-08	8.40E-09	1.08E-07	9.77E-09
78	1.97E-08	1.13E-08	1.97E-08	5.61E-10	1.22E-08	2.86E-08	2.89E-10	1.00E-08	2.02E-08	8.40E-09	1.08E-07	9.77E-09

TABLE D (PART 2).—Total Combined Cancer Risk of All Pollutants from All TAs-Continued

NO.	13	14	15	16	17	18	19	20	21	22	23	24
REC. #	TECE Max. CR	PRDI Max. CR	STYR Max. CR	CDDF Max. CR	As Max. CR	Cd Max. CR	BNZP Max. CR	Cr Vi Max. CR	ACAM Max. CR	1,3-BUT Max. CR	2-NTP Max. CR	1,1,1,2-TCE Max. CR
79	1.97E-08	1.13E-08	1.97E-08	5.61E-10	1.22E-08	2.86E-08	2.89E-10	1.00E-08	2.02E-08	8.40E-09	1.08E-07	9.77E-09
80	1.97E-08	1.13E-08	1.97E-08	5.61E-10	1.22E-08	2.86E-08	2.89E-10	1.00E-08	2.02E-08	8.40E-09	1.08E-07	9.77E-09
81	1.97E-08	1.13E-08	1.97E-08	5.61E-10	1.22E-08	2.86E-08	2.89E-10	1.00E-08	2.02E-08	8.40E-09	1.08E-07	9.77E-09
82	1.97E-08	1.13E-08	1.97E-08	5.61E-10	1.22E-08	2.86E-08	2.89E-10	1.00E-08	2.02E-08	8.40E-09	1.08E-07	9.77E-09
83	1.97E-08	1.13E-08	1.97E-08	5.61E-10	1.22E-08	2.86E-08	2.89E-10	1.00E-08	2.02E-08	8.40E-09	1.08E-07	9.77E-09
84	1.97E-08	1.13E-08	1.97E-08	5.61E-10	1.22E-08	2.86E-08	2.89E-10	1.00E-08	2.02E-08	8.40E-09	1.08E-07	9.77E-09
85	1.97E-08	1.13E-08	1.97E-08	5.61E-10	1.22E-08	2.86E-08	2.89E-10	1.00E-08	2.02E-08	8.40E-09	1.08E-07	9.77E-09
86	1.97E-08	1.13E-08	1.97E-08	5.61E-10	1.22E-08	2.86E-08	2.89E-10	1.00E-08	2.02E-08	8.40E-09	1.08E-07	9.77E-09
87	1.97E-08	1.13E-08	1.97E-08	5.61E-10	1.22E-08	2.86E-08	2.89E-10	1.00E-08	2.02E-08	8.40E-09	1.08E-07	9.77E-09
88	1.97E-08	1.13E-08	1.97E-08	5.61E-10	1.22E-08	2.86E-08	2.89E-10	1.00E-08	2.02E-08	8.40E-09	1.08E-07	9.77E-09
89	1.97E-08	1.13E-08	1.97E-08	5.61E-10	1.22E-08	2.86E-08	2.89E-10	1.00E-08	2.02E-08	8.40E-09	1.08E-07	9.77E-09
90	1.97E-08	1.13E-08	1.97E-08	5.61E-10	1.22E-08	2.86E-08	2.89E-10	1.00E-08	2.02E-08	8.40E-09	1.08E-07	9.77E-09
91	1.97E-08	1.13E-08	1.97E-08	5.61E-10	1.22E-08	2.86E-08	2.89E-10	1.00E-08	2.02E-08	8.40E-09	1.08E-07	9.77E-09
92	1.97E-08	1.13E-08	1.97E-08	5.61E-10	1.22E-08	2.86E-08	2.89E-10	1.00E-08	2.02E-08	8.40E-09	1.08E-07	9.77E-09
93	1.97E-08	1.13E-08	1.97E-08	5.61E-10	1.22E-08	2.86E-08	2.89E-10	1.00E-08	2.02E-08	8.40E-09	1.08E-07	9.77E-09
94	1.97E-08	1.13E-08	1.97E-08	5.61E-10	1.22E-08	2.86E-08	2.89E-10	1.00E-08	2.02E-08	8.40E-09	1.08E-07	9.77E-09
95	1.97E-08	1.13E-08	1.97E-08	5.61E-10	1.22E-08	2.86E-08	2.89E-10	1.00E-08	2.02E-08	8.40E-09	1.08E-07	9.77E-09
96	1.97E-08	1.13E-08	1.97E-08	5.61E-10	1.22E-08	2.86E-08	2.89E-10	1.00E-08	2.02E-08	8.40E-09	1.08E-07	9.77E-09
97	1.97E-08	1.13E-08	1.97E-08	5.61E-10	1.22E-08	2.86E-08	2.89E-10	1.00E-08	2.02E-08	8.40E-09	1.08E-07	9.77E-09
98	1.97E-08	1.13E-08	1.97E-08	5.61E-10	1.22E-08	2.86E-08	2.89E-10	1.00E-08	2.02E-08	8.40E-09	1.08E-07	9.77E-09
99	1.97E-08	1.13E-08	1.97E-08	5.61E-10	1.22E-08	2.86E-08	2.89E-10	1.00E-08	2.02E-08	8.40E-09	1.08E-07	9.77E-09
100	1.97E-08	1.13E-08	1.97E-08	5.61E-10	1.22E-08	2.86E-08	2.89E-10	1.00E-08	2.02E-08	8.40E-09	1.08E-07	9.77E-09
101	1.97E-08	1.13E-08	1.97E-08	5.61E-10	1.22E-08	2.86E-08	2.89E-10	1.00E-08	2.02E-08	8.40E-09	1.08E-07	9.77E-09
102	1.97E-08	1.13E-08	1.97E-08	5.61E-10	1.22E-08	2.86E-08	2.89E-10	1.00E-08	2.02E-08	8.40E-09	1.08E-07	9.77E-09
103	1.97E-08	1.13E-08	1.97E-08	5.61E-10	1.22E-08	2.86E-08	2.89E-10	1.00E-08	2.02E-08	8.40E-09	1.08E-07	9.77E-09
104	1.97E-08	1.13E-08	1.97E-08	5.61E-10	1.22E-08	2.86E-08	2.89E-10	1.00E-08	2.02E-08	8.40E-09	1.08E-07	9.77E-09

TABLE D (PART 2).—Total Combined Cancer Risk of All Pollutants from All TAs-Continued

NO.	13	14	15	16	17	18	19	20	21	22	23	24
REC.#	TECE	PRDI	STYR	CDDF	As	Cd	BNZP	Cr Vi	ACAM	1,3-BUT	2-NTP	1,1,1,2-TCF
	Max. CR	Max. CR	Max. CR	Max. CR	Max. CR	Max. CR	Max. CR	Max. CR	Max. CR	Max. CR	Max. CR	Max. CR
105	1.97E-08	1.13E-08	1.97E-08	5.61E-10	1.22E-08	2.86E-08	2.89E-10	1.00E-08	2.02E-08	8.40E-09	1.08E-07	9.77E-09
106	1.97E-08	1.13E-08	1.97E-08	5.61E-10	1.22E-08	2.86E-08	2.89E-10	1.00E-08	2.02E-08	8.40E-09	1.08E-07	9.77E-09
107	1.97E-08	1.13E-08	1.97E-08	5.61E-10	1.22E-08	2.86E-08	2.89E-10	1.00E-08	2.02E-08	8.40E-09	1.08E-07	9.77E-09
108	1.97E-08	1.13E-08	1.97E-08	5.61E-10	1.22E-08	2.86E-08	2.89E-10	1.00E-08	2.02E-08	8.40E-09	1.08E-07	9.77E-09
109	1.97E-08	1.13E-08	1.97E-08	5.61E-10	1.22E-08	2.86E-08	2.89E-10	1.00E-08	2.02E-08	8.40E-09	1.08E-07	9.77E-09
110	1.97E-08	1.13E-08	1.97E-08	5.61E-10	1.22E-08	2.86E-08	2.89E-10	1.00E-08	2.02E-08	8.40E-09	1.08E-07	9.77E-09
111	1.97E-08	1.13E-08	1.97E-08	5.61E-10	1.22E-08	2.86E-08	2.89E-10	1.00E-08	2.02E-08	8.40E-09	1.08E-07	9.77E-09
112	1.97E-08	1.13E-08	1.97E-08	5.61E-10	1.22E-08	2.86E-08	2.89E-10	1.00E-08	2.02E-08	8.40E-09	1.08E-07	9.77E-09
113	1.97E-08	1.13E-08	1.97E-08	5.61E-10	1.22E-08	2.86E-08	2.89E-10	1.00E-08	2.02E-08	8.40E-09	1.08E-07	9.77E-09
114	1.97E-08	1.13E-08	1.97E-08	5.61E-10	1.22E-08	2.86E-08	2.89E-10	1.00E-08	2.02E-08	8.40E-09	1.08E-07	9.77E-09
115	1.97E-08	1.13E-08	1.97E-08	5.61E-10	1.22E-08	2.86E-08	2.89E-10	1.00E-08	2.02E-08	8.40E-09	1.08E-07	9.77E-09
116	1.97E-08	1.13E-08	1.97E-08	5.61E-10	1.22E-08	2.86E-08	2.89E-10	1.00E-08	2.02E-08	8.40E-09	1.08E-07	9.77E-09
117	1.97E-08	1.13E-08	1.97E-08	5.61E-10	1.22E-08	2.86E-08	2.89E-10	1.00E-08	2.02E-08	8.40E-09	1.08E-07	9.77E-09
118	1.97E-08	1.13E-08	1.97E-08	5.61E-10	1.22E-08	2.86E-08	2.89E-10	1.00E-08	2.02E-08	8.40E-09	1.08E-07	9.77E-09
119	1.97E-08	1.13E-08	1.97E-08	5.61E-10	1.22E-08	2.86E-08	2.89E-10	1.00E-08	2.02E-08	8.40E-09	1.08E-07	9.77E-09
120	1.97E-08	1.13E-08	1.97E-08	5.61E-10	1.22E-08	2.86E-08	2.89E-10	1.00E-08	2.02E-08	8.40E-09	1.08E-07	9.77E-09
121	1.97E-08	1.13E-08	1.97E-08	5.61E-10	1.22E-08	2.86E-08	2.89E-10	1.00E-08	2.02E-08	8.40E-09	1.08E-07	9.77E-09
122	1.97E-08	1.13E-08	1.97E-08	5.61E-10	1.22E-08	2.86E-08	2.89E-10	1.00E-08	2.02E-08	8.40E-09	1.08E-07	9.77E-09
123	1.97E-08	1.13E-08	1.97E-08	5.61E-10	1.22E-08	2.86E-08	2.89E-10	1.00E-08	2.02E-08	8.40E-09	1.08E-07	9.77E-09
124	1.97E-08	1.13E-08	1.97E-08	5.61E-10	1.22E-08	2.86E-08	2.89E-10	1.00E-08	2.02E-08	8.40E-09	1.08E-07	9.77E-09
125	1.97E-08	1.13E-08	1.97E-08	5.61E-10	1.22E-08	2.86E-08	2.89E-10	1.00E-08	2.02E-08	8.40E-09	1.08E-07	9.77E-09
126	1.97E-08	1.13E-08	1.97E-08	5.61E-10	1.22E-08	2.86E-08	2.89E-10	1.00E-08	2.02E-08	8.40E-09	1.08E-07	9.77E-09
127	1.97E-08	1.13E-08	1.97E-08	5.61E-10	1.22E-08	2.86E-08	2.89E-10	1.00E-08	2.02E-08	8.40E-09	1.08E-07	9.77E-09
128	1.97E-08	1.13E-08	1.97E-08	5.61E-10	1.22E-08	2.86E-08	2.89E-10	1.00E-08	2.02E-08	8.40E-09	1.08E-07	9.77E-09
129	1.97E-08	1.13E-08	1.97E-08	5.61E-10	1.22E-08	2.86E-08	2.89E-10	1.00E-08	2.02E-08	8.40E-09	1.08E-07	9.77E-09
130	1.97E-08	1.13E-08	1.97E-08	5.61E-10	1.22E-08	2.86E-08	2.89E-10	1.00E-08	2.02E-08	8.40E-09	1.08E-07	9.77E-09

TABLE D (PART 2).—Total Combined Cancer Risk of All Pollutants from All TAs-Continued

NO.	13	14	15	16	17	18	19	20	21	22	23	24
REC.#	TECE Max. CR	PRDI Max. CR	STYR Max. CR	CDDF Max. CR	As Max. CR	Cd Max. CR	BNZP Max. CR	Cr Vi Max. CR	ACAM Max. CR	1,3-BUT Max. CR	2-NTP Max. CR	1,1,1,2-TCE Max. CR
131	1.97E-08	1.13E-08	1.97E-08	5.61E-10	1.22E-08	2.86E-08	2.89E-10	1.00E-08	2.02E-08	8.40E-09	1.08E-07	9.77E-09
132	1.97E-08	1.13E-08	1.97E-08	5.61E-10	1.22E-08	2.86E-08	2.89E-10	1.00E-08	2.02E-08	8.40E-09	1.08E-07	9.77E-09
133	1.97E-08	1.13E-08	1.97E-08	5.61E-10	1.22E-08	2.86E-08	2.89E-10	1.00E-08	2.02E-08	8.40E-09	1.08E-07	9.77E-09
134	1.97E-08	1.13E-08	1.97E-08	5.61E-10	1.22E-08	2.86E-08	2.89E-10	1.00E-08	2.02E-08	8.40E-09	1.08E-07	9.77E-09
135	1.97E-08	1.13E-08	1.97E-08	5.61E-10	1.22E-08	2.86E-08	2.89E-10	1.00E-08	2.02E-08	8.40E-09	1.08E-07	9.77E-09
136	1.97E-08	1.13E-08	1.97E-08	5.61E-10	1.22E-08	2.86E-08	2.89E-10	1.00E-08	2.02E-08	8.40E-09	1.08E-07	9.77E-09
137	1.97E-08	1.13E-08	1.97E-08	5.61E-10	1.22E-08	2.86E-08	2.89E-10	1.00E-08	2.02E-08	8.40E-09	1.08E-07	9.77E-09
138	1.97E-08	1.13E-08	1.97E-08	5.61E-10	1.22E-08	2.86E-08	2.89E-10	1.00E-08	2.02E-08	8.40E-09	1.08E-07	9.77E-09
139	1.97E-08	1.13E-08	1.97E-08	5.61E-10	1.22E-08	2.86E-08	2.89E-10	1.00E-08	2.02E-08	8.40E-09	1.08E-07	9.77E-09
140	1.97E-08	1.13E-08	1.97E-08	5.61E-10	1.22E-08	2.86E-08	2.89E-10	1.00E-08	2.02E-08	8.40E-09	1.08E-07	9.77E-09
141	1.97E-08	1.13E-08	1.97E-08	5.61E-10	1.22E-08	2.86E-08	2.89E-10	1.00E-08	2.02E-08	8.40E-09	1.08E-07	9.77E-09
142	1.97E-08	1.13E-08	1.97E-08	5.61E-10	1.22E-08	2.86E-08	2.89E-10	1.00E-08	2.02E-08	8.40E-09	1.08E-07	9.77E-09
143	1.97E-08	1.13E-08	1.97E-08	5.61E-10	1.22E-08	2.86E-08	2.89E-10	1.00E-08	2.02E-08	8.40E-09	1.08E-07	9.77E-09
144	1.97E-08	1.13E-08	1.97E-08	5.61E-10	1.22E-08	2.86E-08	2.89E-10	1.00E-08	2.02E-08	8.40E-09	1.08E-07	9.77E-09
145	1.97E-08	1.13E-08	1.97E-08	5.61E-10	1.22E-08	2.86E-08	2.89E-10	1.00E-08	2.02E-08	8.40E-09	1.08E-07	9.77E-09
146	1.97E-08	1.13E-08	1.97E-08	5.61E-10	1.22E-08	2.86E-08	2.89E-10	1.00E-08	2.02E-08	8.40E-09	1.08E-07	9.77E-09
147	1.97E-08	1.13E-08	1.97E-08	5.61E-10	1.22E-08	2.86E-08	2.89E-10	1.00E-08	2.02E-08	8.40E-09	1.08E-07	9.77E-09
148	1.97E-08	1.13E-08	1.97E-08	5.61E-10	1.22E-08	2.86E-08	2.89E-10	1.00E-08	2.02E-08	8.40E-09	1.08E-07	9.77E-09
149	1.97E-08	1.13E-08	1.97E-08	5.61E-10	1.22E-08	2.86E-08	2.89E-10	1.00E-08	2.02E-08	8.40E-09	1.08E-07	9.77E-09
150	1.97E-08	1.13E-08	1.97E-08	5.61E-10	1.22E-08	2.86E-08	2.89E-10	1.00E-08	2.02E-08	8.40E-09	1.08E-07	9.77E-09
151	1.97E-08	1.13E-08	1.97E-08	5.61E-10	1.22E-08	2.86E-08	2.89E-10	1.00E-08	2.02E-08	8.40E-09	1.08E-07	9.77E-09
152	1.97E-08	1.13E-08	1.97E-08	5.61E-10	1.22E-08	2.86E-08	2.89E-10	1.00E-08	2.02E-08	8.40E-09	1.08E-07	9.77E-09
153	1.97E-08	1.13E-08	1.97E-08	5.61E-10	1.22E-08	2.86E-08	2.89E-10	1.00E-08	2.02E-08	8.40E-09	1.08E-07	9.77E-09
154	1.97E-08	1.13E-08	1.97E-08	5.61E-10	1.22E-08	2.86E-08	2.89E-10	1.00E-08	2.02E-08	8.40E-09	1.08E-07	9.77E-09
155	1.97E-08	1.13E-08	1.97E-08	5.61E-10	1.22E-08	2.86E-08	2.89E-10	1.00E-08	2.02E-08	8.40E-09	1.08E-07	9.77E-09
156	1.97E-08	1.13E-08	1.97E-08	5.61E-10	1.22E-08	2.86E-08	2.89E-10	1.00E-08	2.02E-08	8.40E-09	1.08E-07	9.77E-09

TABLE D (PART 2).—Total Combined Cancer Risk of All Pollutants from All TAs-Continued

NO.	13	14	15	16	17	18	19	20	21	22	23	24
REC.#	TECE	PRDI	STYR	CDDF	As	Cd	BNZP	Cr Vi	ACAM	1,3-BUT	2-NTP	1,1,1,2-TCF
	Max. CR	Max. CR	Max. CR	Max. CR	Max. CR	Max. CR	Max. CR	Max. CR	Max. CR	Max. CR	Max. CR	Max. CR
157	1.97E-08	1.13E-08	1.97E-08	5.61E-10	1.22E-08	2.86E-08	2.89E-10	1.00E-08	2.02E-08	8.40E-09	1.08E-07	9.77E-09
158	1.97E-08	1.13E-08	1.97E-08	5.61E-10	1.22E-08	2.86E-08	2.89E-10	1.00E-08	2.02E-08	8.40E-09	1.08E-07	9.77E-09
159	1.97E-08	1.13E-08	1.97E-08	5.61E-10	1.22E-08	2.86E-08	2.89E-10	1.00E-08	2.02E-08	8.40E-09	1.08E-07	9.77E-09
160	1.97E-08	1.13E-08	1.97E-08	5.61E-10	1.22E-08	2.86E-08	2.89E-10	1.00E-08	2.02E-08	8.40E-09	1.08E-07	9.77E-09
161	1.97E-08	1.13E-08	1.97E-08	5.61E-10	1.22E-08	2.86E-08	2.89E-10	1.00E-08	2.02E-08	8.40E-09	1.08E-07	9.77E-09
162	1.97E-08	1.13E-08	1.97E-08	5.61E-10	1.22E-08	2.86E-08	2.89E-10	1.00E-08	2.02E-08	8.40E-09	1.08E-07	9.77E-09
163	1.97E-08	1.13E-08	1.97E-08	5.61E-10	1.22E-08	2.86E-08	2.89E-10	1.00E-08	2.02E-08	8.40E-09	1.08E-07	9.77E-09
164	1.97E-08	1.13E-08	1.97E-08	5.61E-10	1.22E-08	2.86E-08	2.89E-10	1.00E-08	2.02E-08	8.40E-09	1.08E-07	9.77E-09
165	1.97E-08	1.13E-08	1.97E-08	5.61E-10	1.22E-08	2.86E-08	2.89E-10	1.00E-08	2.02E-08	8.40E-09	1.08E-07	9.77E-09
166	1.97E-08	1.13E-08	1.97E-08	5.61E-10	1.22E-08	2.86E-08	2.89E-10	1.00E-08	2.02E-08	8.40E-09	1.08E-07	9.77E-09
167	1.97E-08	1.13E-08	1.97E-08	5.61E-10	1.22E-08	2.86E-08	2.89E-10	1.00E-08	2.02E-08	8.40E-09	1.08E-07	9.77E-09
168	1.97E-08	1.13E-08	1.97E-08	5.61E-10	1.22E-08	2.86E-08	2.89E-10	1.00E-08	2.02E-08	8.40E-09	1.08E-07	9.77E-09
169	1.97E-08	1.13E-08	1.97E-08	5.61E-10	1.22E-08	2.86E-08	2.89E-10	1.00E-08	2.02E-08	8.40E-09	1.08E-07	9.77E-09
170	1.97E-08	1.13E-08	1.97E-08	5.61E-10	1.22E-08	2.86E-08	2.89E-10	1.00E-08	2.02E-08	8.40E-09	1.08E-07	9.77E-09
171	1.97E-08	1.13E-08	1.97E-08	5.61E-10	1.22E-08	2.86E-08	2.89E-10	1.00E-08	2.02E-08	8.40E-09	1.08E-07	9.77E-09
172	1.97E-08	1.13E-08	1.97E-08	5.61E-10	1.22E-08	2.86E-08	2.89E-10	1.00E-08	2.02E-08	8.40E-09	1.08E-07	9.77E-09
173	1.97E-08	1.13E-08	1.97E-08	5.61E-10	1.22E-08	2.86E-08	2.89E-10	1.00E-08	2.02E-08	8.40E-09	1.08E-07	9.77E-09
174	1.97E-08	1.13E-08	1.97E-08	5.61E-10	1.22E-08	2.86E-08	2.89E-10	1.00E-08	2.02E-08	8.40E-09	1.08E-07	9.77E-09
175	1.04E-08	9.53E-09	1.03E-08	2.97E-10	9.55E-09	3.76E-09	1.53E-10	1.24E-09	1.92E-08	0.00E+00	0.00E+00	5.18E-10
176	1.08E-08	9.47E-09	1.07E-08	3.30E-11	1.03E-08	4.17E-09	1.70E-10	1.30E-09	1.51E-08	0.00E+00	0.00E+00	5.18E-10
177	1.04E-08	9.10E-09	1.03E-08	3.33E-11	9.89E-09	4.19E-09	1.70E-10	1.28E-09	1.34E-08	0.00E+00	0.00E+00	5.18E-10
178	1.06E-08	9.79E-09	1.06E-08	2.97E-10	9.98E-09	3.87E-09	1.53E-10	1.26E-09	1.38E-08	0.00E+00	0.00E+00	5.18E-10
179	1.11E-08	9.50E-09	1.10E-08	3.30E-11	1.02E-08	4.46E-09	1.70E-10	1.33E-09	9.49E-09	0.00E+00	0.00E+00	5.92E-10
180	1.20E-08	1.12E-08	1.20E-08	6.60E-11	1.19E-08	3.90E-09	1.70E-10	1.27E-09	2.02E-08	0.00E+00	0.00E+00	5.18E-10

TABLE D (PART 3).—Total Combined Cancer Risk of All Pollutants from All TAs

NO.	REC. #	25	26	27	28	29	30	31	32	33	34	35		TOTAL COMBINED CR
		1,1,2-TCE Max. CR	1,1,2-TCE Max. CR	HECE Max. CR	HECB Max. CR	VINC Max. CR	DIEA Max. CR	EPCH Max. CR	ALCH Max. CR	ETOX Max. CR	BNCH Max. CR	HDRZ Max. CR		
1		2.03E-08	3.90E-08	9.80E-09	9.46E-09	1.01E-08	8.41E-09	1.00E-08	9.85E-09	1.00E-08	1.01E-08	1.62E-08	1.62E-08	6.67E-07
2		2.03E-08	3.90E-08	9.80E-09	9.46E-09	1.01E-08	8.41E-09	1.00E-08	9.85E-09	1.00E-08	1.01E-08	1.62E-08	1.62E-08	6.73E-07
3		2.03E-08	3.90E-08	9.80E-09	9.46E-09	1.01E-08	8.41E-09	1.00E-08	9.85E-09	1.00E-08	1.01E-08	1.62E-08	1.62E-08	6.38E-07
4		2.03E-08	3.90E-08	9.80E-09	9.46E-09	1.01E-08	8.41E-09	1.00E-08	9.85E-09	1.00E-08	1.01E-08	1.62E-08	1.62E-08	6.31E-07
5		2.03E-08	3.90E-08	9.80E-09	9.46E-09	1.01E-08	8.41E-09	1.00E-08	9.85E-09	1.00E-08	1.01E-08	1.62E-08	1.62E-08	6.42E-07
6		2.03E-08	3.90E-08	9.80E-09	9.46E-09	1.01E-08	8.41E-09	1.00E-08	9.85E-09	1.00E-08	1.01E-08	1.62E-08	1.62E-08	6.36E-07
7		2.03E-08	3.90E-08	9.80E-09	9.46E-09	1.01E-08	8.41E-09	1.00E-08	9.85E-09	1.00E-08	1.01E-08	1.62E-08	1.62E-08	6.52E-07
8		2.03E-08	3.90E-08	9.80E-09	9.46E-09	1.01E-08	8.41E-09	1.00E-08	9.85E-09	1.00E-08	1.01E-08	1.62E-08	1.62E-08	6.30E-07
9		2.03E-08	3.90E-08	9.80E-09	9.46E-09	1.01E-08	8.41E-09	1.00E-08	9.85E-09	1.00E-08	1.01E-08	1.62E-08	1.62E-08	6.20E-07
10		2.03E-08	3.90E-08	9.80E-09	9.46E-09	1.01E-08	8.41E-09	1.00E-08	9.85E-09	1.00E-08	1.01E-08	1.62E-08	1.62E-08	6.48E-07
11		2.03E-08	3.90E-08	9.80E-09	9.46E-09	1.01E-08	8.41E-09	1.00E-08	9.85E-09	1.00E-08	1.01E-08	1.62E-08	1.62E-08	6.64E-07
12		2.03E-08	3.90E-08	9.80E-09	9.46E-09	1.01E-08	8.41E-09	1.00E-08	9.85E-09	1.00E-08	1.01E-08	1.62E-08	1.62E-08	6.50E-07
13		2.03E-08	3.90E-08	9.80E-09	9.46E-09	1.01E-08	8.41E-09	1.00E-08	9.85E-09	1.00E-08	1.01E-08	1.62E-08	1.62E-08	6.32E-07
14		2.03E-08	3.90E-08	9.80E-09	9.46E-09	1.01E-08	8.41E-09	1.00E-08	9.85E-09	1.00E-08	1.01E-08	1.62E-08	1.62E-08	6.15E-07
15		2.03E-08	3.90E-08	9.80E-09	9.46E-09	1.01E-08	8.41E-09	1.00E-08	9.85E-09	1.00E-08	1.01E-08	1.62E-08	1.62E-08	6.16E-07
16		2.03E-08	3.90E-08	9.80E-09	9.46E-09	1.01E-08	8.41E-09	1.00E-08	9.85E-09	1.00E-08	1.01E-08	1.62E-08	1.62E-08	6.20E-07
17		2.03E-08	3.90E-08	9.80E-09	9.46E-09	1.01E-08	8.41E-09	1.00E-08	9.85E-09	1.00E-08	1.01E-08	1.62E-08	1.62E-08	6.58E-07
18		2.03E-08	3.90E-08	9.80E-09	9.46E-09	1.01E-08	8.41E-09	1.00E-08	9.85E-09	1.00E-08	1.01E-08	1.62E-08	1.62E-08	6.88E-07
19		2.03E-08	3.90E-08	9.80E-09	9.46E-09	1.01E-08	8.41E-09	1.00E-08	9.85E-09	1.00E-08	1.01E-08	1.62E-08	1.62E-08	6.83E-07
20		2.03E-08	3.90E-08	9.80E-09	9.46E-09	1.01E-08	8.41E-09	1.00E-08	9.85E-09	1.00E-08	1.01E-08	1.62E-08	1.62E-08	6.64E-07
21		2.03E-08	3.90E-08	9.80E-09	9.46E-09	1.01E-08	8.41E-09	1.00E-08	9.85E-09	1.00E-08	1.01E-08	1.62E-08	1.62E-08	6.53E-07
22		2.03E-08	3.90E-08	9.80E-09	9.46E-09	1.01E-08	8.41E-09	1.00E-08	9.85E-09	1.00E-08	1.01E-08	1.62E-08	1.62E-08	6.39E-07
23		2.03E-08	3.90E-08	9.80E-09	9.46E-09	1.01E-08	8.41E-09	1.00E-08	9.85E-09	1.00E-08	1.01E-08	1.62E-08	1.62E-08	6.08E-07
24		2.03E-08	3.90E-08	9.80E-09	9.46E-09	1.01E-08	8.41E-09	1.00E-08	9.85E-09	1.00E-08	1.01E-08	1.62E-08	1.62E-08	6.55E-07
25		2.03E-08	3.90E-08	9.80E-09	9.46E-09	1.01E-08	8.41E-09	1.00E-08	9.85E-09	1.00E-08	1.01E-08	1.62E-08	1.62E-08	6.89E-07
26		2.03E-08	3.90E-08	9.80E-09	9.46E-09	1.01E-08	8.41E-09	1.00E-08	9.85E-09	1.00E-08	1.01E-08	1.62E-08	1.62E-08	6.60E-07

TABLE D (PART 3).—Total Combined Cancer Risk of All Pollutants from All TAs—Continued

NO.	REC. #	25	26	27	28	29	30	31	32	33	34	35		TOTAL COMBINED CR
		1,1,2-TCE Max. CR	1,1,2-TCE Max. CR	HECE Max. CR	HECB Max. CR	VINC Max. CR	DIEA Max. CR	EPCH Max. CR	ALCH Max. CR	ETOX Max. CR	BNCH Max. CR	HDRZ Max. CR	Max. CR	
27		2.03E-08	3.90E-08	9.80E-09	9.46E-09	1.01E-08	8.41E-09	1.00E-08	9.85E-09	1.00E-08	1.01E-08	1.62E-08	1.62E-08	8.08E-07
28		1.74E-09	2.35E-08	5.20E-10	4.40E-10	8.40E-10	5.56E-10	1.20E-10	1.64E-10	0.00E+00	8.40E-10	1.45E-09	1.45E-09	8.05E-07
29		2.03E-08	3.90E-08	9.80E-09	9.46E-09	1.01E-08	8.41E-09	1.00E-08	9.85E-09	1.00E-08	1.01E-08	1.62E-08	1.62E-08	8.47E-07
30		2.03E-08	3.90E-08	9.80E-09	9.46E-09	1.01E-08	8.41E-09	1.00E-08	9.85E-09	1.00E-08	1.01E-08	1.62E-08	1.62E-08	7.54E-07
31		2.03E-08	3.90E-08	9.80E-09	9.46E-09	1.01E-08	8.41E-09	1.00E-08	9.85E-09	1.00E-08	1.01E-08	1.62E-08	1.62E-08	6.72E-07
32		2.03E-08	3.90E-08	9.80E-09	9.46E-09	1.01E-08	8.41E-09	1.00E-08	9.85E-09	1.00E-08	1.01E-08	1.62E-08	1.62E-08	6.71E-07
33		2.03E-08	3.90E-08	9.80E-09	9.46E-09	1.01E-08	8.41E-09	1.00E-08	9.85E-09	1.00E-08	1.01E-08	1.62E-08	1.62E-08	5.78E-07
34		2.03E-08	3.90E-08	9.80E-09	9.46E-09	1.01E-08	8.41E-09	1.00E-08	9.85E-09	1.00E-08	1.01E-08	1.62E-08	1.62E-08	5.89E-07
35		2.03E-08	3.90E-08	9.80E-09	9.46E-09	1.01E-08	8.41E-09	1.00E-08	9.85E-09	1.00E-08	1.01E-08	1.62E-08	1.62E-08	5.63E-07
36		2.03E-08	3.90E-08	9.80E-09	9.46E-09	1.01E-08	8.41E-09	1.00E-08	9.85E-09	1.00E-08	1.01E-08	1.62E-08	1.62E-08	5.61E-07
37		2.03E-08	3.90E-08	9.80E-09	9.46E-09	1.01E-08	8.41E-09	1.00E-08	9.85E-09	1.00E-08	1.01E-08	1.62E-08	1.62E-08	5.60E-07
38		2.03E-08	3.90E-08	9.80E-09	9.46E-09	1.01E-08	8.41E-09	1.00E-08	9.85E-09	1.00E-08	1.01E-08	1.62E-08	1.62E-08	5.85E-07
39		2.03E-08	3.90E-08	9.80E-09	9.46E-09	1.01E-08	8.41E-09	1.00E-08	9.85E-09	1.00E-08	1.01E-08	1.62E-08	1.62E-08	5.44E-07
40		2.03E-08	3.90E-08	9.80E-09	9.46E-09	1.01E-08	8.41E-09	1.00E-08	9.85E-09	1.00E-08	1.01E-08	1.62E-08	1.62E-08	5.34E-07
41		2.03E-08	3.90E-08	9.80E-09	9.46E-09	1.01E-08	8.41E-09	1.00E-08	9.85E-09	1.00E-08	1.01E-08	1.62E-08	1.62E-08	5.35E-07
42		2.03E-08	3.90E-08	9.80E-09	9.46E-09	1.01E-08	8.41E-09	1.00E-08	9.85E-09	1.00E-08	1.01E-08	1.62E-08	1.62E-08	5.22E-07
43		2.03E-08	3.90E-08	9.80E-09	9.46E-09	1.01E-08	8.41E-09	1.00E-08	9.85E-09	1.00E-08	1.01E-08	1.62E-08	1.62E-08	5.41E-07
44		2.03E-08	3.90E-08	9.80E-09	9.46E-09	1.01E-08	8.41E-09	1.00E-08	9.85E-09	1.00E-08	1.01E-08	1.62E-08	1.62E-08	5.36E-07
45		2.03E-08	3.90E-08	9.80E-09	9.46E-09	1.01E-08	8.41E-09	1.00E-08	9.85E-09	1.00E-08	1.01E-08	1.62E-08	1.62E-08	5.46E-07
46		2.03E-08	3.90E-08	9.80E-09	9.46E-09	1.01E-08	8.41E-09	1.00E-08	9.85E-09	1.00E-08	1.01E-08	1.62E-08	1.62E-08	5.57E-07
47		2.03E-08	3.90E-08	9.80E-09	9.46E-09	1.01E-08	8.41E-09	1.00E-08	9.85E-09	1.00E-08	1.01E-08	1.62E-08	1.62E-08	5.70E-07
48		2.03E-08	3.90E-08	9.80E-09	9.46E-09	1.01E-08	8.41E-09	1.00E-08	9.85E-09	1.00E-08	1.01E-08	1.62E-08	1.62E-08	5.62E-07
49		2.03E-08	3.90E-08	9.80E-09	9.46E-09	1.01E-08	8.41E-09	1.00E-08	9.85E-09	1.00E-08	1.01E-08	1.62E-08	1.62E-08	5.79E-07
50		2.03E-08	3.90E-08	9.80E-09	9.46E-09	1.01E-08	8.41E-09	1.00E-08	9.85E-09	1.00E-08	1.01E-08	1.62E-08	1.62E-08	5.44E-07
51		2.03E-08	3.90E-08	9.80E-09	9.46E-09	1.01E-08	8.41E-09	1.00E-08	9.85E-09	1.00E-08	1.01E-08	1.62E-08	1.62E-08	5.50E-07
52		2.03E-08	3.90E-08	9.80E-09	9.46E-09	1.01E-08	8.41E-09	1.00E-08	9.85E-09	1.00E-08	1.01E-08	1.62E-08	1.62E-08	5.52E-07

TABLE D (PART 3).—Total Combined Cancer Risk of All Pollutants from All TAs-Continued

NO.	REC. #	25	26	27	28	29	30	31	32	33	34	35	TOTAL COMBINED CR
		1,1,2-TCE Max. CR	1,1,2-TCE Max. CR	HECE Max. CR	HECB Max. CR	VINC Max. CR	DIEA Max. CR	EPCH Max. CR	ALCH Max. CR	ETOX Max. CR	BNCH Max. CR	HDRZ Max. CR	
53		2.03E-08	3.90E-08	9.80E-09	9.46E-09	1.01E-08	8.41E-09	1.00E-08	9.85E-09	1.00E-08	1.01E-08	1.62E-08	5.59E-07
54		2.03E-08	3.90E-08	9.80E-09	9.46E-09	1.01E-08	8.41E-09	1.00E-08	9.85E-09	1.00E-08	1.01E-08	1.62E-08	5.49E-07
55		2.03E-08	3.90E-08	9.80E-09	9.46E-09	1.01E-08	8.41E-09	1.00E-08	9.85E-09	1.00E-08	1.01E-08	1.62E-08	5.58E-07
56		2.03E-08	3.90E-08	9.80E-09	9.46E-09	1.01E-08	8.41E-09	1.00E-08	9.85E-09	1.00E-08	1.01E-08	1.62E-08	5.60E-07
57		2.03E-08	3.90E-08	9.80E-09	9.46E-09	1.01E-08	8.41E-09	1.00E-08	9.85E-09	1.00E-08	1.01E-08	1.62E-08	5.65E-07
58		2.03E-08	3.90E-08	9.80E-09	9.46E-09	1.01E-08	8.41E-09	1.00E-08	9.85E-09	1.00E-08	1.01E-08	1.62E-08	5.67E-07
59		2.03E-08	3.90E-08	9.80E-09	9.46E-09	1.01E-08	8.41E-09	1.00E-08	9.85E-09	1.00E-08	1.01E-08	1.62E-08	5.74E-07
60		2.03E-08	3.90E-08	9.80E-09	9.46E-09	1.01E-08	8.41E-09	1.00E-08	9.85E-09	1.00E-08	1.01E-08	1.62E-08	5.74E-07
61		2.03E-08	3.90E-08	9.80E-09	9.46E-09	1.01E-08	8.41E-09	1.00E-08	9.85E-09	1.00E-08	1.01E-08	1.62E-08	5.68E-07
62		2.03E-08	3.90E-08	9.80E-09	9.46E-09	1.01E-08	8.41E-09	1.00E-08	9.85E-09	1.00E-08	1.01E-08	1.62E-08	5.54E-07
63		2.03E-08	3.90E-08	9.80E-09	9.46E-09	1.01E-08	8.41E-09	1.00E-08	9.85E-09	1.00E-08	1.01E-08	1.62E-08	5.58E-07
64		2.03E-08	3.90E-08	9.80E-09	9.46E-09	1.01E-08	8.41E-09	1.00E-08	9.85E-09	1.00E-08	1.01E-08	1.62E-08	5.60E-07
65		2.03E-08	3.90E-08	9.80E-09	9.46E-09	1.01E-08	8.41E-09	1.00E-08	9.85E-09	1.00E-08	1.01E-08	1.62E-08	5.69E-07
66		2.03E-08	3.90E-08	9.80E-09	9.46E-09	1.01E-08	8.41E-09	1.00E-08	9.85E-09	1.00E-08	1.01E-08	1.62E-08	5.57E-07
67		2.03E-08	3.90E-08	9.80E-09	9.46E-09	1.01E-08	8.41E-09	1.00E-08	9.85E-09	1.00E-08	1.01E-08	1.62E-08	5.61E-07
68		2.03E-08	3.90E-08	9.80E-09	9.46E-09	1.01E-08	8.41E-09	1.00E-08	9.85E-09	1.00E-08	1.01E-08	1.62E-08	5.68E-07
69		2.03E-08	3.90E-08	9.80E-09	9.46E-09	1.01E-08	8.41E-09	1.00E-08	9.85E-09	1.00E-08	1.01E-08	1.62E-08	5.52E-07
70		2.03E-08	3.90E-08	9.80E-09	9.46E-09	1.01E-08	8.41E-09	1.00E-08	9.85E-09	1.00E-08	1.01E-08	1.62E-08	5.45E-07
71		2.03E-08	3.90E-08	9.80E-09	9.46E-09	1.01E-08	8.41E-09	1.00E-08	9.85E-09	1.00E-08	1.01E-08	1.62E-08	5.39E-07
72		2.03E-08	3.90E-08	9.80E-09	9.46E-09	1.01E-08	8.41E-09	1.00E-08	9.85E-09	1.00E-08	1.01E-08	1.62E-08	5.44E-07
73		2.03E-08	3.90E-08	9.80E-09	9.46E-09	1.01E-08	8.41E-09	1.00E-08	9.85E-09	1.00E-08	1.01E-08	1.62E-08	5.74E-07
74		2.03E-08	3.90E-08	9.80E-09	9.46E-09	1.01E-08	8.41E-09	1.00E-08	9.85E-09	1.00E-08	1.01E-08	1.62E-08	5.36E-07
75		2.03E-08	3.90E-08	9.80E-09	9.46E-09	1.01E-08	8.41E-09	1.00E-08	9.85E-09	1.00E-08	1.01E-08	1.62E-08	5.61E-07
76		2.03E-08	3.90E-08	9.80E-09	9.46E-09	1.01E-08	8.41E-09	1.00E-08	9.85E-09	1.00E-08	1.01E-08	1.62E-08	6.39E-07
77		2.03E-08	3.90E-08	9.80E-09	9.46E-09	1.01E-08	8.41E-09	1.00E-08	9.85E-09	1.00E-08	1.01E-08	1.62E-08	5.39E-07
78		2.03E-08	3.90E-08	9.80E-09	9.46E-09	1.01E-08	8.41E-09	1.00E-08	9.85E-09	1.00E-08	1.01E-08	1.62E-08	7.39E-07

TABLE D (PART 3).—Total Combined Cancer Risk of All Pollutants from All TAs-Continued

NO.	REC.#	25	26	27	28	29	30	31	32	33	34	35		TOTAL COMBINED CR
		1,1,2,2-TCE Max. CR	1,1,2-TCE Max. CR	HECE Max. CR	HECB Max. CR	VINC Max. CR	DIEA Max. CR	EPCH Max. CR	ALCH Max. CR	ETOX Max. CR	BNCH Max. CR	HDRZ Max. CR		
79		2.03E-08	3.90E-08	9.80E-09	9.46E-09	1.01E-08	8.41E-09	1.00E-08	9.85E-09	1.00E-08	1.01E-08	1.62E-08	1.62E-08	4.92E-07
80		2.03E-08	3.90E-08	9.80E-09	9.46E-09	1.01E-08	8.41E-09	1.00E-08	9.85E-09	1.00E-08	1.01E-08	1.62E-08	1.62E-08	4.92E-07
81		2.03E-08	3.90E-08	9.80E-09	9.46E-09	1.01E-08	8.41E-09	1.00E-08	9.85E-09	1.00E-08	1.01E-08	1.62E-08	1.62E-08	5.13E-07
82		2.03E-08	3.90E-08	9.80E-09	9.46E-09	1.01E-08	8.41E-09	1.00E-08	9.85E-09	1.00E-08	1.01E-08	1.62E-08	1.62E-08	5.71E-07
83		2.03E-08	3.90E-08	9.80E-09	9.46E-09	1.01E-08	8.41E-09	1.00E-08	9.85E-09	1.00E-08	1.01E-08	1.62E-08	1.62E-08	5.79E-07
84		2.03E-08	3.90E-08	9.80E-09	9.46E-09	1.01E-08	8.41E-09	1.00E-08	9.85E-09	1.00E-08	1.01E-08	1.62E-08	1.62E-08	6.92E-07
85		2.03E-08	3.90E-08	9.80E-09	9.46E-09	1.01E-08	8.41E-09	1.00E-08	9.85E-09	1.00E-08	1.01E-08	1.62E-08	1.62E-08	5.73E-07
86		2.03E-08	3.90E-08	9.80E-09	9.46E-09	1.01E-08	8.41E-09	1.00E-08	9.85E-09	1.00E-08	1.01E-08	1.62E-08	1.62E-08	5.00E-07
87		2.03E-08	3.90E-08	9.80E-09	9.46E-09	1.01E-08	8.41E-09	1.00E-08	9.85E-09	1.00E-08	1.01E-08	1.62E-08	1.62E-08	5.69E-07
88		2.03E-08	3.90E-08	9.80E-09	9.46E-09	1.01E-08	8.41E-09	1.00E-08	9.85E-09	1.00E-08	1.01E-08	1.62E-08	1.62E-08	5.49E-07
89		2.03E-08	3.90E-08	9.80E-09	9.46E-09	1.01E-08	8.41E-09	1.00E-08	9.85E-09	1.00E-08	1.01E-08	1.62E-08	1.62E-08	4.83E-07
90		2.03E-08	3.90E-08	9.80E-09	9.46E-09	1.01E-08	8.41E-09	1.00E-08	9.85E-09	1.00E-08	1.01E-08	1.62E-08	1.62E-08	4.84E-07
91		2.03E-08	3.90E-08	9.80E-09	9.46E-09	1.01E-08	8.41E-09	1.00E-08	9.85E-09	1.00E-08	1.01E-08	1.62E-08	1.62E-08	4.83E-07
92		2.03E-08	3.90E-08	9.80E-09	9.46E-09	1.01E-08	8.41E-09	1.00E-08	9.85E-09	1.00E-08	1.01E-08	1.62E-08	1.62E-08	4.85E-07
93		2.03E-08	3.90E-08	9.80E-09	9.46E-09	1.01E-08	8.41E-09	1.00E-08	9.85E-09	1.00E-08	1.01E-08	1.62E-08	1.62E-08	4.89E-07
94		2.03E-08	3.90E-08	9.80E-09	9.46E-09	1.01E-08	8.41E-09	1.00E-08	9.85E-09	1.00E-08	1.01E-08	1.62E-08	1.62E-08	4.83E-07
95		2.03E-08	3.90E-08	9.80E-09	9.46E-09	1.01E-08	8.41E-09	1.00E-08	9.85E-09	1.00E-08	1.01E-08	1.62E-08	1.62E-08	4.84E-07
96		2.03E-08	3.90E-08	9.80E-09	9.46E-09	1.01E-08	8.41E-09	1.00E-08	9.85E-09	1.00E-08	1.01E-08	1.62E-08	1.62E-08	4.83E-07
97		2.03E-08	3.90E-08	9.80E-09	9.46E-09	1.01E-08	8.41E-09	1.00E-08	9.85E-09	1.00E-08	1.01E-08	1.62E-08	1.62E-08	4.84E-07
98		2.03E-08	3.90E-08	9.80E-09	9.46E-09	1.01E-08	8.41E-09	1.00E-08	9.85E-09	1.00E-08	1.01E-08	1.62E-08	1.62E-08	4.85E-07
99		2.03E-08	3.90E-08	9.80E-09	9.46E-09	1.01E-08	8.41E-09	1.00E-08	9.85E-09	1.00E-08	1.01E-08	1.62E-08	1.62E-08	4.86E-07
100		2.03E-08	3.90E-08	9.80E-09	9.46E-09	1.01E-08	8.41E-09	1.00E-08	9.85E-09	1.00E-08	1.01E-08	1.62E-08	1.62E-08	4.87E-07
101		2.03E-08	3.90E-08	9.80E-09	9.46E-09	1.01E-08	8.41E-09	1.00E-08	9.85E-09	1.00E-08	1.01E-08	1.62E-08	1.62E-08	4.94E-07
102		2.03E-08	3.90E-08	9.80E-09	9.46E-09	1.01E-08	8.41E-09	1.00E-08	9.85E-09	1.00E-08	1.01E-08	1.62E-08	1.62E-08	4.95E-07
103		2.03E-08	3.90E-08	9.80E-09	9.46E-09	1.01E-08	8.41E-09	1.00E-08	9.85E-09	1.00E-08	1.01E-08	1.62E-08	1.62E-08	4.95E-07
104		2.03E-08	3.90E-08	9.80E-09	9.46E-09	1.01E-08	8.41E-09	1.00E-08	9.85E-09	1.00E-08	1.01E-08	1.62E-08	1.62E-08	4.93E-07

TABLE D (PART 3).—Total Combined Cancer Risk of All Pollutants from All TAs-Continued

NO.	REC. #	25	26	27	28	29	30	31	32	33	34	35	TOTAL COMBINED CR
		1,1,2,2-TCE Max. CR	1,1,2-TCE Max. CR	HECE Max. CR	HECB Max. CR	VINC Max. CR	DIEA Max. CR	EPCH Max. CR	ALCH Max. CR	ETOX Max. CR	BNCH Max. CR	HDRZ Max. CR	
105		2.03E-08	3.90E-08	9.80E-09	9.46E-09	1.01E-08	8.41E-09	1.00E-08	9.85E-09	1.00E-08	1.01E-08	1.62E-08	4.92E-07
106		2.03E-08	3.90E-08	9.80E-09	9.46E-09	1.01E-08	8.41E-09	1.00E-08	9.85E-09	1.00E-08	1.01E-08	1.62E-08	5.06E-07
107		2.03E-08	3.90E-08	9.80E-09	9.46E-09	1.01E-08	8.41E-09	1.00E-08	9.85E-09	1.00E-08	1.01E-08	1.62E-08	5.04E-07
108		2.03E-08	3.90E-08	9.80E-09	9.46E-09	1.01E-08	8.41E-09	1.00E-08	9.85E-09	1.00E-08	1.01E-08	1.62E-08	5.00E-07
109		2.03E-08	3.90E-08	9.80E-09	9.46E-09	1.01E-08	8.41E-09	1.00E-08	9.85E-09	1.00E-08	1.01E-08	1.62E-08	4.97E-07
110		2.03E-08	3.90E-08	9.80E-09	9.46E-09	1.01E-08	8.41E-09	1.00E-08	9.85E-09	1.00E-08	1.01E-08	1.62E-08	4.98E-07
111		2.03E-08	3.90E-08	9.80E-09	9.46E-09	1.01E-08	8.41E-09	1.00E-08	9.85E-09	1.00E-08	1.01E-08	1.62E-08	4.88E-07
112		2.03E-08	3.90E-08	9.80E-09	9.46E-09	1.01E-08	8.41E-09	1.00E-08	9.85E-09	1.00E-08	1.01E-08	1.62E-08	4.85E-07
113		2.03E-08	3.90E-08	9.80E-09	9.46E-09	1.01E-08	8.41E-09	1.00E-08	9.85E-09	1.00E-08	1.01E-08	1.62E-08	4.88E-07
114		2.03E-08	3.90E-08	9.80E-09	9.46E-09	1.01E-08	8.41E-09	1.00E-08	9.85E-09	1.00E-08	1.01E-08	1.62E-08	4.84E-07
115		2.03E-08	3.90E-08	9.80E-09	9.46E-09	1.01E-08	8.41E-09	1.00E-08	9.85E-09	1.00E-08	1.01E-08	1.62E-08	4.85E-07
116		2.03E-08	3.90E-08	9.80E-09	9.46E-09	1.01E-08	8.41E-09	1.00E-08	9.85E-09	1.00E-08	1.01E-08	1.62E-08	4.84E-07
117		2.03E-08	3.90E-08	9.80E-09	9.46E-09	1.01E-08	8.41E-09	1.00E-08	9.85E-09	1.00E-08	1.01E-08	1.62E-08	4.85E-07
118		2.03E-08	3.90E-08	9.80E-09	9.46E-09	1.01E-08	8.41E-09	1.00E-08	9.85E-09	1.00E-08	1.01E-08	1.62E-08	4.96E-07
119		2.03E-08	3.90E-08	9.80E-09	9.46E-09	1.01E-08	8.41E-09	1.00E-08	9.85E-09	1.00E-08	1.01E-08	1.62E-08	4.96E-07
120		2.03E-08	3.90E-08	9.80E-09	9.46E-09	1.01E-08	8.41E-09	1.00E-08	9.85E-09	1.00E-08	1.01E-08	1.62E-08	4.95E-07
121		2.03E-08	3.90E-08	9.80E-09	9.46E-09	1.01E-08	8.41E-09	1.00E-08	9.85E-09	1.00E-08	1.01E-08	1.62E-08	4.84E-07
122		2.03E-08	3.90E-08	9.80E-09	9.46E-09	1.01E-08	8.41E-09	1.00E-08	9.85E-09	1.00E-08	1.01E-08	1.62E-08	5.10E-07
123		2.03E-08	3.90E-08	9.80E-09	9.46E-09	1.01E-08	8.41E-09	1.00E-08	9.85E-09	1.00E-08	1.01E-08	1.62E-08	4.91E-07
124		2.03E-08	3.90E-08	9.80E-09	9.46E-09	1.01E-08	8.41E-09	1.00E-08	9.85E-09	1.00E-08	1.01E-08	1.62E-08	4.85E-07
125		2.03E-08	3.90E-08	9.80E-09	9.46E-09	1.01E-08	8.41E-09	1.00E-08	9.85E-09	1.00E-08	1.01E-08	1.62E-08	4.84E-07
126		2.03E-08	3.90E-08	9.80E-09	9.46E-09	1.01E-08	8.41E-09	1.00E-08	9.85E-09	1.00E-08	1.01E-08	1.62E-08	4.83E-07
127		2.03E-08	3.90E-08	9.80E-09	9.46E-09	1.01E-08	8.41E-09	1.00E-08	9.85E-09	1.00E-08	1.01E-08	1.62E-08	4.83E-07
128		2.03E-08	3.90E-08	9.80E-09	9.46E-09	1.01E-08	8.41E-09	1.00E-08	9.85E-09	1.00E-08	1.01E-08	1.62E-08	4.86E-07
129		2.03E-08	3.90E-08	9.80E-09	9.46E-09	1.01E-08	8.41E-09	1.00E-08	9.85E-09	1.00E-08	1.01E-08	1.62E-08	4.84E-07
130		2.03E-08	3.90E-08	9.80E-09	9.46E-09	1.01E-08	8.41E-09	1.00E-08	9.85E-09	1.00E-08	1.01E-08	1.62E-08	4.83E-07

TABLE D (PART 3).—Total Combined Cancer Risk of All Pollutants from All TAs—Continued

NO.	REC. #	25	26	27	28	29	30	31	32	33	34	35		TOTAL COMBINED CR
		1,1,2-TCE Max. CR	1,1,2-TCE Max. CR	HECE Max. CR	HECB Max. CR	VINC Max. CR	DIEA Max. CR	EPCH Max. CR	ALCH Max. CR	ETOX Max. CR	BNCH Max. CR	HDRZ Max. CR		
131		2.03E-08	3.90E-08	9.80E-09	9.46E-09	1.01E-08	8.41E-09	1.00E-08	9.85E-09	1.00E-08	1.01E-08	1.62E-08	1.62E-08	4.82E-07
132		2.03E-08	3.90E-08	9.80E-09	9.46E-09	1.01E-08	8.41E-09	1.00E-08	9.85E-09	1.00E-08	1.01E-08	1.62E-08	1.62E-08	4.82E-07
133		2.03E-08	3.90E-08	9.80E-09	9.46E-09	1.01E-08	8.41E-09	1.00E-08	9.85E-09	1.00E-08	1.01E-08	1.62E-08	1.62E-08	4.83E-07
134		2.03E-08	3.90E-08	9.80E-09	9.46E-09	1.01E-08	8.41E-09	1.00E-08	9.85E-09	1.00E-08	1.01E-08	1.62E-08	1.62E-08	4.82E-07
135		2.03E-08	3.90E-08	9.80E-09	9.46E-09	1.01E-08	8.41E-09	1.00E-08	9.85E-09	1.00E-08	1.01E-08	1.62E-08	1.62E-08	4.84E-07
136		2.03E-08	3.90E-08	9.80E-09	9.46E-09	1.01E-08	8.41E-09	1.00E-08	9.85E-09	1.00E-08	1.01E-08	1.62E-08	1.62E-08	4.92E-07
137		2.03E-08	3.90E-08	9.80E-09	9.46E-09	1.01E-08	8.41E-09	1.00E-08	9.85E-09	1.00E-08	1.01E-08	1.62E-08	1.62E-08	4.84E-07
138		2.03E-08	3.90E-08	9.80E-09	9.46E-09	1.01E-08	8.41E-09	1.00E-08	9.85E-09	1.00E-08	1.01E-08	1.62E-08	1.62E-08	5.67E-07
139		2.03E-08	3.90E-08	9.80E-09	9.46E-09	1.01E-08	8.41E-09	1.00E-08	9.85E-09	1.00E-08	1.01E-08	1.62E-08	1.62E-08	4.83E-07
140		2.03E-08	3.90E-08	9.80E-09	9.46E-09	1.01E-08	8.41E-09	1.00E-08	9.85E-09	1.00E-08	1.01E-08	1.62E-08	1.62E-08	4.83E-07
141		2.03E-08	3.90E-08	9.80E-09	9.46E-09	1.01E-08	8.41E-09	1.00E-08	9.85E-09	1.00E-08	1.01E-08	1.62E-08	1.62E-08	4.85E-07
142		2.03E-08	3.90E-08	9.80E-09	9.46E-09	1.01E-08	8.41E-09	1.00E-08	9.85E-09	1.00E-08	1.01E-08	1.62E-08	1.62E-08	5.29E-07
143		2.03E-08	3.90E-08	9.80E-09	9.46E-09	1.01E-08	8.41E-09	1.00E-08	9.85E-09	1.00E-08	1.01E-08	1.62E-08	1.62E-08	4.88E-07
144		2.03E-08	3.90E-08	9.80E-09	9.46E-09	1.01E-08	8.41E-09	1.00E-08	9.85E-09	1.00E-08	1.01E-08	1.62E-08	1.62E-08	4.82E-07
145		2.03E-08	3.90E-08	9.80E-09	9.46E-09	1.01E-08	8.41E-09	1.00E-08	9.85E-09	1.00E-08	1.01E-08	1.62E-08	1.62E-08	4.83E-07
146		2.03E-08	3.90E-08	9.80E-09	9.46E-09	1.01E-08	8.41E-09	1.00E-08	9.85E-09	1.00E-08	1.01E-08	1.62E-08	1.62E-08	4.84E-07
147		2.03E-08	3.90E-08	9.80E-09	9.46E-09	1.01E-08	8.41E-09	1.00E-08	9.85E-09	1.00E-08	1.01E-08	1.62E-08	1.62E-08	5.54E-07
148		2.03E-08	3.90E-08	9.80E-09	9.46E-09	1.01E-08	8.41E-09	1.00E-08	9.85E-09	1.00E-08	1.01E-08	1.62E-08	1.62E-08	5.68E-07
149		2.03E-08	3.90E-08	9.80E-09	9.46E-09	1.01E-08	8.41E-09	1.00E-08	9.85E-09	1.00E-08	1.01E-08	1.62E-08	1.62E-08	5.49E-07
150		2.03E-08	3.90E-08	9.80E-09	9.46E-09	1.01E-08	8.41E-09	1.00E-08	9.85E-09	1.00E-08	1.01E-08	1.62E-08	1.62E-08	5.59E-07
151		2.03E-08	3.90E-08	9.80E-09	9.46E-09	1.01E-08	8.41E-09	1.00E-08	9.85E-09	1.00E-08	1.01E-08	1.62E-08	1.62E-08	5.74E-07
152		2.03E-08	3.90E-08	9.80E-09	9.46E-09	1.01E-08	8.41E-09	1.00E-08	9.85E-09	1.00E-08	1.01E-08	1.62E-08	1.62E-08	5.96E-07
153		2.03E-08	3.90E-08	9.80E-09	9.46E-09	1.01E-08	8.41E-09	1.00E-08	9.85E-09	1.00E-08	1.01E-08	1.62E-08	1.62E-08	5.35E-07
154		2.03E-08	3.90E-08	9.80E-09	9.46E-09	1.01E-08	8.41E-09	1.00E-08	9.85E-09	1.00E-08	1.01E-08	1.62E-08	1.62E-08	5.45E-07
155		2.03E-08	3.90E-08	9.80E-09	9.46E-09	1.01E-08	8.41E-09	1.00E-08	9.85E-09	1.00E-08	1.01E-08	1.62E-08	1.62E-08	5.35E-07
156		2.03E-08	3.90E-08	9.80E-09	9.46E-09	1.01E-08	8.41E-09	1.00E-08	9.85E-09	1.00E-08	1.01E-08	1.62E-08	1.62E-08	5.34E-07

TABLE D (PART 3).—Total Combined Cancer Risk of All Pollutants from All TAs-Continued

NO.	REC. #	25	26	27	28	29	30	31	32	33	34	35	TOTAL COMBINED CR
		1,1,2-TCE Max. CR	1,1,2-TCE Max. CR	HECE Max. CR	HECB Max. CR	VINC Max. CR	DIEA Max. CR	EPCH Max. CR	ALCH Max. CR	ETOX Max. CR	BNCH Max. CR	HDRZ Max. CR	
157		2.03E-08	3.90E-08	9.80E-09	9.46E-09	1.01E-08	8.41E-09	1.00E-08	9.85E-09	1.00E-08	1.01E-08	1.62E-08	5.37E-07
158		2.03E-08	3.90E-08	9.80E-09	9.46E-09	1.01E-08	8.41E-09	1.00E-08	9.85E-09	1.00E-08	1.01E-08	1.62E-08	5.53E-07
159		2.03E-08	3.90E-08	9.80E-09	9.46E-09	1.01E-08	8.41E-09	1.00E-08	9.85E-09	1.00E-08	1.01E-08	1.62E-08	5.53E-07
160		2.03E-08	3.90E-08	9.80E-09	9.46E-09	1.01E-08	8.41E-09	1.00E-08	9.85E-09	1.00E-08	1.01E-08	1.62E-08	5.40E-07
161		2.03E-08	3.90E-08	9.80E-09	9.46E-09	1.01E-08	8.41E-09	1.00E-08	9.85E-09	1.00E-08	1.01E-08	1.62E-08	5.63E-07
162		2.03E-08	3.90E-08	9.80E-09	9.46E-09	1.01E-08	8.41E-09	1.00E-08	9.85E-09	1.00E-08	1.01E-08	1.62E-08	5.64E-07
163		2.03E-08	3.90E-08	9.80E-09	9.46E-09	1.01E-08	8.41E-09	1.00E-08	9.85E-09	1.00E-08	1.01E-08	1.62E-08	5.73E-07
164		2.03E-08	3.90E-08	9.80E-09	9.46E-09	1.01E-08	8.41E-09	1.00E-08	9.85E-09	1.00E-08	1.01E-08	1.62E-08	5.11E-07
165		2.03E-08	3.90E-08	9.80E-09	9.46E-09	1.01E-08	8.41E-09	1.00E-08	9.85E-09	1.00E-08	1.01E-08	1.62E-08	5.11E-07
166		2.03E-08	3.90E-08	9.80E-09	9.46E-09	1.01E-08	8.41E-09	1.00E-08	9.85E-09	1.00E-08	1.01E-08	1.62E-08	5.15E-07
167		2.03E-08	3.90E-08	9.80E-09	9.46E-09	1.01E-08	8.41E-09	1.00E-08	9.85E-09	1.00E-08	1.01E-08	1.62E-08	5.17E-07
168		2.03E-08	3.90E-08	9.80E-09	9.46E-09	1.01E-08	8.41E-09	1.00E-08	9.85E-09	1.00E-08	1.01E-08	1.62E-08	5.54E-07
169		2.03E-08	3.90E-08	9.80E-09	9.46E-09	1.01E-08	8.41E-09	1.00E-08	9.85E-09	1.00E-08	1.01E-08	1.62E-08	6.27E-07
170		2.03E-08	3.90E-08	9.80E-09	9.46E-09	1.01E-08	8.41E-09	1.00E-08	9.85E-09	1.00E-08	1.01E-08	1.62E-08	6.03E-07
171		2.03E-08	3.90E-08	9.80E-09	9.46E-09	1.01E-08	8.41E-09	1.00E-08	9.85E-09	1.00E-08	1.01E-08	1.62E-08	6.15E-07
172		2.03E-08	3.90E-08	9.80E-09	9.46E-09	1.01E-08	8.41E-09	1.00E-08	9.85E-09	1.00E-08	1.01E-08	1.62E-08	6.22E-07
173		2.03E-08	3.90E-08	9.80E-09	9.46E-09	1.01E-08	8.41E-09	1.00E-08	9.85E-09	1.00E-08	1.01E-08	1.62E-08	6.16E-07
174		2.03E-08	3.90E-08	9.80E-09	9.46E-09	1.01E-08	8.41E-09	1.00E-08	9.85E-09	1.00E-08	1.01E-08	1.62E-08	6.04E-07
175		1.74E-09	2.19E-08	5.20E-10	4.40E-10	8.40E-10	5.40E-10	1.20E-10	1.61E-10	0.00E+00	8.40E-10	1.40E-09	1.17E-06
176		1.74E-09	2.30E-08	5.60E-10	4.40E-10	8.40E-10	5.59E-10	1.20E-10	1.65E-10	0.00E+00	8.40E-10	1.46E-09	9.73E-07
177		1.74E-09	2.24E-08	5.20E-10	4.40E-10	8.40E-10	5.62E-10	1.20E-10	1.65E-10	0.00E+00	8.40E-10	1.45E-09	8.26E-07
178		1.74E-09	2.26E-08	5.20E-10	4.40E-10	8.40E-10	5.48E-10	1.20E-10	1.62E-10	0.00E+00	8.40E-10	1.42E-09	8.59E-07

TABLE D (PART 3).—Total Combined Cancer Risk of All Pollutants from All TAs-Continued

NO.	25	26	27	28	29	30	31	32	33	34	35	TOTAL COMBINED CR
REC. #	1,1,2,2-TCE	1,1,2-TCE	HECE	HECB	VINC	DIEA	EPCH	ALCH	ETOX	BNCH	HDRZ	Max. CR
	Max. CR	Max. CR	Max. CR	Max. CR	Max. CR	Max. CR	Max. CR	Max. CR	Max. CR	Max. CR	Max. CR	
179	1.74E-09	2.32E-08	5.60E-10	4.40E-10	8.40E-10	5.74E-10	1.20E-10	1.68E-10	0.00E+00	8.40E-10	1.49E-09	7.07E-07
180	1.74E-09	2.50E-08	5.20E-10	4.40E-10	8.40E-10	5.43E-10	1.20E-10	1.62E-10	0.00E+00	8.40E-10	1.45E-09	1.07E-06

Receptor ID Numbers:

1. CHLF = Chloroform; 2. FORM = Formaldehyde; 3. TRCE = Trichloroethylene; 4. MECH = Methylene Chloride; 5. Be = Beryllium; 6. MTCH = Methyl Chloride; 7. ETDC = Ethylene Dichloride; 8. CCL4 = Carbon Tetrachloride; 9. NI = Nickel; 10. BENZ = Benzene; 11. ACAL = Acetaldehyde; 12. ETAC = Ethyl Acrylate; 13. TECE = Tetrachloroethylene; 14. PRDI = Propylene Dichloride; 15. STYR = Styrene; 16. CDDF = 2,3,7,8-Tetrachlorodibenzo(p)dioxin; 17. As = Arsenic; 18. Cd = Cadmium; 19. BNZP = Benzo(p)pyrene; 20. Cr VI = Hexavalent Chromium; 21. ACAM = Acrylamide; 22. 1,3-BUT = 1,3-Butadiene; 23. 2-NTP = 2-Nitropropane; 24. 1,1,1,2-TCE = 1,1,1,2-Tetrachloroethane; 25. 1,1,2,2-TCE = 1,1,2,2-Tetrachloroethane; 26. 1,1,2-Trichloroethane; 27. HECE = Hexachloroethane; 28. HECB = Hexachlorobutadiene; 29. VINC = Vinyl Chloride; 30. DIEA = Diethanolamine; 31. 1,1,2,2-Tetrachloroethane; 32. ALCH = Allyl Chloride; 33. ETOX = Ethylene Oxide; 34. BNCH = Benzyl Chloride; 35. HDRZ = Hydrazine.

Notes:

Max. CR = Maximum cancer risk due to each pollutant.

Total Combined CR = total estimated cancer risk of all pollutants combined.

Dispersion Analysis:

- The additive impact analysis was conducted with the EPA's ISC-3 model using 5 years of on-site meteorological data.
- The total of 35 carcinogenic pollutants that have the potential to be released from LANL operations were considered in the analysis. Emission rates of these pollutants and the appropriate unit risk factors are presented in Tables A and C.
- Maximum cancer risk was obtained by multiplying of the estimated annual concentration of a specific pollutant by its unit risk factor (EPA 1992f and EPA 1993b).
- The total potential combined cancer risks were estimated by summing the cancer risks due to each individual pollutant at each of the 180 receptor locations.

Major Assumptions:

- Emissions would be released simultaneously from LANL operations over 8,760 hours a year.
- Incremental cancer risks are additive.

Other Assumptions Include:

- All chemicals are released to the atmosphere, rather than used in process or product or sent to waste disposal or recycling after use.
- There is no time spent indoors or inside automobiles; whereas, people actually spend more than 80% of their time indoors. Being inside would cut the concentration by half as a minimum.

ATTACHMENT 7

AIR QUALITY IMPACT ASSESSMENT OF THE TA-3 CHEMICAL AND METALLURGY RESEARCH FACILITY (CMR) METHYLENE CHLORIDE EMISSIONS

Technical Area: TA-3, CMR Facility

Emission Source(s)

An emission source of methylene chloride is located at the CMR Facility, Building 29 (Stack ID FE-20). Methylene chloride is used for analysis of soil samples. During the concentrating phase, the extracted methylene chloride is evaporated and emitted to the atmosphere.

Source Term Parameters

Stack parameters and their locations are provided in Table A.

Emission Rates of Pollutants Considered

The annual emission rate of methylene chloride was estimated to be 700 pounds a year under the Expanded Operations Alternative operating schedule (Table A). It was assumed that these emissions would be released over 8,760 hours of operation per year.

Dispersion Modeling Analysis

Air quality impacts analysis was conducted with the EPA's ISC-3 Model using 5 years of on-site meteorological data. All nearby buildings within the zone of plume influence were considered in the downwash analysis. The highest annual average concentration estimated by the ISC-3 Model at any of sensitive receptors was used to estimate the incremental cancer risk of the methylene chloride release using its unit risk factor.

Results

Results of the analysis are presented in Tables B and C. As shown in Table C, the maximum cancer risk associated with release of methylene chloride from Building 29 of the TA-3 CMR facility is below the Guideline Value of 1.0×10^{-8} .

TABLE A.—Stack Parameters and Emission Rate of the Methylene Chloride Associated with the TA-3 CMR Facility (Building 29)

NO.	EMISSION SOURCE	STACK ID	STACK PARAMETERS				ESTIMATED ANNUAL EMISSION RATE	
			UTM COORD. (X; Y)	HEIGHT	VELOCITY	DIAMETER	lb/year	g/sec
			m	m	m/sec	m		
1	TA-3 CMR Facility (Building 29)	Bldg 29 (FE-20)	380752; 3970257	15.90	17.20	1.10	700.0	0.0101

TABLE B.—ISC-3 Estimated Annual Concentration of the Methylene Chloride Associated with Emission Source of the TA-3 CMR Facility Using 1991-1995 Meteorological Data

EMISSION SOURCE	ISC-3 ESTIMATED ANNUAL AVERAGE CONCENTRATION ($\mu\text{g}/\text{m}^3$)			
	METEOROLOGICAL DATA			
	1991	1992	1993	1994
TA-3 CMR Facility (Building 29)	6.80E-03	6.02E-03	7.35E-03	7.31E-03
				6.91E-03

TABLE C.—Results of the Dispersion Modeling Analysis of the Methylene Chloride Emissions from the CMR Facility of the TA-3

NO.	EMISSION SOURCE	METHYLENE CHLORIDE UNIT RISK FACTOR (URF)	ISC-3 ESTIMATED ANNUAL CONCENTRATION (C_{an})	MAXIMUM CANCER RISK ($C_{an} \times \text{URF}$)	GUIDELINE VALUE
		($\mu\text{g}/\text{m}^3$) ⁻¹	$\mu\text{g}/\text{m}^3$		
1	2	3	4	5	6
1	TA-3 CMR Facility (Building 29)	4.70E-07	7.35E-03	3.45E-09	1.00E-08

ATTACHMENT 8

AIR QUALITY IMPACT ASSESSMENT OF THE TA-3 BERYLLIUM EMISSIONS

Technical Area: TA-3, Buildings 102 and SM141

Emission Source(s)

Beryllium process development and machining operations at TA-3 are conducted in support of ongoing beryllium research and are currently being refurbished. Beryllium machining operations conducted at TA-3-39 will be relocated to the new Sigma beryllium TA-3-141 in order to consolidate the majority of the beryllium processing conducted at LANL. The permitted beryllium operations conducted at TA-3-102, TA-35-213, and TA-55, and the registered beryllium sources at TA-3-29 and TA-66 will remain in place. The modified SM141 beryllium facility also will incorporate operations and equipment from other DOE complexes.

Emissions from the two stacks, one on the TA-3 Building 102, and the other on the Building SM141, were considered in the analysis.

Source Term Parameters

Stack parameters and their locations are shown in Table A.

Emission Rates of Pollutants Considered

Annual emission rates of beryllium were estimated based on the draft permit application for SM141 and the existing air quality permit for the TA-3-102 facility. Emissions from these facilities are released to the atmosphere through a high efficiency particulate air (HEPA) filtration system, with a removal efficiency of 99.95 percent. Controlled emission rates are estimated to be 0.11 pounds per year for SM141 facility, and 1.4×10^{-4} pounds per year for the TA-3-102 facility.

Estimated annual emission rates of beryllium that were used in the analysis are shown in Table A. It was assumed that emissions would be released over 8,760 hours of operation per year.

Dispersion Modeling Analysis

An air quality impacts analysis was conducted using EPA's ISC-3 Model and 5 years of on-site meteorological data. All nearby buildings, including Buildings 102 and SM141, within the zone of stack plume influence were considered in the downwash analysis. The highest annual concentration estimated by the ISC-3 Model (Table B) was used to compute the maximum combined cancer risk of beryllium releases using its unit risk factor.

Results

Results of the analysis are presented in Tables B and C. As shown in Table C, the combined cancer risk associated with releases of beryllium from Buildings 102 and SM141 of the TA-3 facility is 2.41×10^{-9} , which is below the Guideline Value of 1.0×10^{-8} .

TABLE A.—Stack Parameters and Beryllium Annual Emission Rate Associated with Buildings 102 and SM141 of the TA-3 Facility

NO.	SOURCE	STACK ID	STACK PARAMETERS				ANNUAL PERMITTED EMISSION RATE	
			UTM COORD. (X; Y)	HEIGHT	VELOCITY	DIAMETER	lb/year	g/sec
1	TA-3 Building 102	B102	380476; 3970171	13.70	5.88	0.91	1.40E-04	2.02E-09
2	TA-3 Building 141	B141	381219; 3970330	15.24	14.30	1.52	1.10E-01	1.58E-06

TABLE B.—TA-3 ISC-3 Estimated Annual Average Concentration of the Beryllium Using 1991 to 1995 Meteorological Data

EMISSION SOURCE	ISC-3 ESTIMATED ANNUAL AVERAGE CONCENTRATION ($\mu\text{g}/\text{m}^3$)			
	METEOROLOGICAL DATA			
	1991	1992	1993	1994
TA-3 Buildings 102 & SM141	7.82E-07	8.48E-07	1.00E-06	8.88E-07
				1995
				8.87E-07

TABLE C.—Results of the Dispersion Modeling Analysis of the Beryllium Emissions from TA-3

NO.	EMISSION SOURCE	BERYLLIUM UNIT RISK FACTOR (URF) ($\mu\text{g}/\text{m}^3$) ⁻¹	ISC-3 ESTIMATED ANNUAL CONC. ¹ (C_{an}) $\mu\text{g}/\text{m}^3$	COMBINED MAXIMUM CANCER RISK ($C_{\text{an}} \times \text{URF}$)	GUIDELINE VALUE
1	TA-3 Buildings 102 & SM141	2.40E-03	1.00E-06	2.41E-09	1.00E-08

ATTACHMENT 9

AIR QUALITY IMPACT ASSESSMENT OF THE TA-3 SHOPS COMPLEX NICKEL DUST EMISSIONS

Technical Area: TA-3, Shops Complex

Emission Source(s)

The Shops Complex contains machining and inspection equipment to support LANL. The missions supported include nuclear weapons technology, stockpile management, nuclear materials production, and general fabrication. Nickel is machined in Building 102 of the Shops Complex facility.

Source Term Parameters

Stack parameters and locations are provided in Table A.

Emission Rates of Pollutants Considered

The nickel dust generated from the machining process is exhausted through a series of in-line high efficiency particulate air (HEPA) filters before entering a common shops baghouse control system and exiting to the atmosphere. The HEPA filter has a rated control efficiency of 99.97 percent, and the baghouse has a measured control efficiency of 80 percent. The amount of nickel currently being machined is approximately 10 percent of what was machined in 1990. The estimated annual emission rate of the nickel dust used in the dispersion analysis is shown in Table A. It was assumed that annual emissions would be released over 8,760 hours of operation per year.

Dispersion Modeling Analysis

An air quality impacts analysis was conducted with EPA's ISC-3 Model using 5 years of on-site meteorological data. All nearby buildings within the zone of plume influence were considered in the downwash analysis. The highest annual average concentration estimated by the ISC-3 Model at any of sensitive receptors was used to estimate the incremental cancer risk of the nickel release using its unit risk factor.

Results

Results of the analysis are presented in Tables B and C. As shown in Table C, the maximum cancer risk associated with release of the nickel dust from Shops Complex Building 102 of the TA-3 facility is below the Guideline Value of 1.0×10^{-8} .

TABLE A.—Stack Parameters and Emission Rate of the Nickel Dust Associated with TA-3 Shops Complex (Building 102)

NO.	EMISSION SOURCE	STACK ID	STACK PARAMETERS				ESTIMATED ANNUAL EMISSION RATE	
			UTM COORD. (X; Y)	HEIGHT	VELOCITY	DIAMETER	lb/year	g/sec
			m	m	m/sec	m		
1	TA-3 Shops Complex (Building 102)	Building 102	380476; 3970171	13.70	5.88	0.91	1.58 x 10 ⁻³	2.27 x 10 ⁻⁸

TABLE B.—ISC-3 Estimated Annual Concentration of the Nickel Dust Associated with Emission Source of the TA-3 Shops Complex Using Meteorological Data (1991 to 1995)

EMISSION SOURCE	ISC-3 ESTIMATED ANNUAL AVERAGE CONCENTRATION (µg/m ³)				
	METEOROLOGICAL DATA				
	1991	1992	1993	1994	1995
TA-3 Shops Complex (Building 102)	2.70 x 10 ⁻⁸	2.40 x 10 ⁻⁸	3.00 x 10 ⁻⁸	2.60 x 10 ⁻⁸	2.70 x 10 ⁻⁸

TABLE C.—Results of the Dispersion Modeling Analysis of the Nickel Dust Emissions from Shops Complex (Building 102) of TA-3

NO.	EMISSION SOURCE	NICKEL UNIT RISK FACTOR (URF)	ISC-3 ESTIMATED ANNUAL CONCENTRATION (C _{an})	MAXIMUM CANCER RISK (C _{an} X URF)	GUIDELINE VALUE
		(µg/m ³) ⁻¹	µg/m ³	X URF	
1	TA-3 Shops Complex (Building 102)	2.40 x 10 ⁻⁴	3.00 x 10 ⁻⁸	7.20 x 10 ⁻¹²	1.00 x 10 ⁻⁸

ATTACHMENT 10

AIR QUALITY IMPACT ASSESSMENT OF PAINT BOOTH EMISSIONS

Technical Areas: TA–3, Building 38; TA–3, Building 39; and TA–60, Building 17

Emission Source: Paint Booth Operations

Paint booth operations occur at TA–3–38, TA–3–39, and TA–60–17.

Pollutant(s) Considered

There are seven toxic, noncarcinogenic pollutants and one carcinogenic air pollutant that have the potential to be released into the atmosphere from the paint booth located at TA–3–38. The noncarcinogenic pollutants are 2-butoxyethanol, isobutyl acetate, isopropyl alcohol, toluene, trimethyl benzene, xylene, and particulate matter. The carcinogenic pollutant is benzene. These chemicals are constituents of oil-based paint and paint thinner. Of these, toluene, trimethyl benzene, xylene, and benzene are constituents of oil-based paint. Isopropyl alcohol, 2-butoxyethanol, isobutyl acetate, and toluene are constituents of the paint thinner.

Because the chemical composition of the paints and thinner at TA–3–39 and TA–60–17 were not provided, it was assumed that paints and thinner compositions to be used at paint booths at TA–3–39 and TA–60–17 are similar to those used at the TA–3–38 paint booth.

Emission Rates of Pollutants Considered

To estimate annual emissions from painting operations from the paint booths, the information giving the quantity of paints and thinner used annually at each TA and their density was obtained. This information is presented in Tables A through E for each TA in the footnotes. It was assumed that type and duration of painting operations conducted at TA–60–17 in 1994 (i.e., 528 hours per year of operations consisted of 240 hours per year of rack painting, plus 288 hours per year of maintenance painting) would apply to all painting activities conducted at the TA–3–38 and TA–3–39 paint booths. Hourly emission rates were estimated for 528 hours of operations per year using a correction factor of five to approximate maximum hourly emission rates. That is, the hourly emission rates were estimated by dividing annual emission rates by 528 hours and then multiplying this value by five.

Estimated hourly and annual emission rates of toxic (noncarcinogenic and carcinogenic) air pollutants from paint booths at TA–3–38, TA–3–39, and TA–60–17 are presented in Tables A through F.

Emissions were modeled with EPA's ISC–3 Model as point sources located on specified buildings (TA–3 Buildings 38 and 39, TA–60 Building 17). The source terms were estimated based on engineering judgment (stack height = 32.8 feet [10 meters], building height = 31.17 feet [9.5 meters], stack diameter = 1.15 feet [0.35 meters], exit velocity = 16.41 feet per second [5 meters per second], and exit temperature = 293°K).

Two paint booth impact analyses were conducted, one to estimate short-term (8-hour) impacts of noncarcinogenic and carcinogenic pollutants, and one to estimate long-term annual impacts of carcinogenic pollutants.

Major Assumptions Used in the Analysis

- All paints and thinners used at TA-3-39 and TA-60-17 have similar composition and constituents as those identified for paints and thinner at TA-3-38.
- The type and duration of painting operations conducted at TA-60-17 would apply to all painting activities conducted at TA-3-38 and TA-3-39 paint booths.
- Content of fine particles (less than 10 micrometers in size) is 50 percent of the total particulate matter content.
- Five percent of PM₁₀ content would be released into the atmosphere through the emission control equipment.

Results

Analysis of short-term (8-hour) impacts of noncarcinogenic air pollutants that have the potential to be released into the atmosphere under baseline conditions and under future alternatives show no impacts on ambient air quality. The SLEV/Q^h ratios for all pollutants considered are all greater than one (Tables A, C, and E). That is, the estimated pollutant levels are below the established Guideline Values (GVs).

Results of the annual impacts analysis of the carcinogenic pollutant presented in Tables B, D, and F show that benzene emitted from TA-3-38 and TA-60-17 failed the analysis with an SLEV/Q^{an} ratio less than one. That is, the estimated benzene level is greater than the established GV. This pollutant was further evaluated in the additive impact analysis.

TABLE A.—8-Hour SLEV/Q Ratios of the Toxic (Noncarcinogenic and Carcinogenic) Air Pollutants from TA-3-38 Paint Booth¹

NO.	TOXIC AIR POLLUTANTS	CAS NUMBER	OEEL ⁶	1/100 OF THE OEEL ⁷	8-HR SLEV ⁸		ESTIMATED HOURLY EMISSION RATE (Q) ^{h2}	SLEV/Q ^h RATIO
			µg/m ³	µg/m ³	g/sec	lb/hr		
1	2	3	4	5	6	7	8	9
NONCARCINOGENIC POLLUTANTS								
1	2-Butoxyethanol	111-76-2	120,000	1,200	4.54	36.1	0.366	98.5
2	Isobutyl Acetate	110-19-0	700,000	7,000	26.5	210.0	1.28	164.0
3	Isopropyl Alcohol	67-63-0	980,000	9,800	37.1	294.0	0.732	402.0
4	Particulate Matter, Respirable Dust ^{3,4,5}	NA	3,000	30.0	0.114	0.901	0.200	45.1
5	Toluene	108-88-3	188,000	1,880	7.12	56.5	1.44	39.1
6	Trimethyl Benzene	25551-13-7	125,000	1,250	4.73	37.6	1.08	34.9
7	Xylene (o-, m-, p-Isomers)	1330-20-7	434,000	4,340	16.4	130.0	6.46	20.2
CARCINOGENIC POLLUTANTS								
8	Benzene	71-43-2	32,000	320	1.21	9.62	0.0215	446.0

TABLE A.—8-Hour SLEV/Q Ratios of the Toxic (Noncarcinogenic and Carcinogenic) Air Pollutants from TA-3-38 Paint Booth¹

Site Operations Data:

- The amount of oil-based paint used annually is 250 gal./year.
- The constituents of the paint are toluene (5% by weight), trimethyl benzene (5% by weight), xylene (30% by weight), and benzene (0.1% by weight).
- The highest density of the paint is 9.1 lb/gal.
- The amount of paint thinner used annually with a density of 6.9 lb/gal. is 56 gal.
- The constituents of the thinner are toluene (10% by weight), isopropyl alcohol (20% by weight), 2-Butoxyethanol (10% by weight), and isobutyl acetate (35% by weight).

Notes:

Major Assumptions:

- ¹ Type and duration of painting operations conducted at TA-60-17 in 1994 (528 hours/year of operation consisted of 240 hours/year of rack painting, plus 288 hours/year of maintenance painting) would apply to all painting activities conducted at TA-3-38 paint booth.
- ² Hourly emission rates were estimated based upon 528 hours/year of operation using a correction factor of five to approximate the maximum potential hourly emission rate.
- ³ Particulate emissions of 10 micrometers in size (PM₁₀) were estimated based upon the solids content of a paint and amount of total particulates emitted from TA-3-38 paint booth (844 lb/year).
- ⁴ Content of fine particles PM₁₀ is 50% of the total particulate matter content.
- ⁵ 5% of the PM₁₀ content would be released into the atmosphere.

Guideline Value(s):

⁶ OEL = occupational exposure limits established by the American Conference of Governmental Industrial Hygienists (ACGIH 1997).

⁷ 1/100 of the OEL is 8-hour guideline value used in the analysis to estimate short-term impacts of the toxic air pollutants.

Dispersion Analysis Results:

- ⁸ 5 years of meteorological data were used in the dispersion modeling analysis. The highest ISC-3 estimated 8-hour concentration at fence line receptors was found to be 264.1 µg/m³ when emission rate is 1 g/sec.

NA = Not applicable

TABLE B.—Annual SLEV/Q Ratios of the Carcinogenic Pollutants from TA-3-38 Paint Booth

NO.	CARCINOGENIC POLLUTANT	CAS NUMBER	CAR CLASS	UNIT RISK FACTOR (URF) ($\mu\text{g}/\text{m}^3$) ⁻¹	MAXIMUM CANCER RISK ($C_{\text{an}} \times \text{URF}$) ³	ANNUAL SLEV ¹		ANNUAL EMISSION RATE (Q) ²	RATIO SLEV/Q ^a
						g/sec	lb/year		
1	2	3	4	5	6	7	8	9	10
1	Benzene	71-43-2	A	8.30E-06	2.35E-05	4.25E-04	1.78E+00	2.28E+00	7.84E-01

Site Operations Data:

- The amount of oil-based paint used annually is 250 gal./year.
- The benzene content of the paint is 0.1% by weight.
- The highest density of the paint is 9.1 lb/gal.

Notes:

Major Assumptions:

- ¹ Type and duration of painting operations conducted at TA-60-17 in 1994 (528 hours of operation consisted of 240 hours/year of rack painting, plus 288 hours/year of maintenance painting) would apply to all painting activities conducted at TA-3-38 paint booth.
- ² Emission rate was estimated based upon amount of paint used annually and benzene content of the paint.

Dispersion Analysis Results:

- ³ 5 years of meteorological data were used in the dispersion modeling analysis. The highest ISC-3 estimated annual concentration at sensitive receptors was found to be 2.83 $\mu\text{g}/\text{m}^3$ when emission rate is 1 g/sec.

TABLE C.—8-Hour SLEV/Q Ratios of the Toxic (Noncarcinogenic and Carcinogenic) Air Pollutants from TA-3-38 Paint Booth¹

NO.	TOXIC AIR POLLUTANTS	CAS NUMBER	OEL ⁷ µg/m ³	1/100 OF THE OEL ⁸		8-HR SLEV ⁹		ESTIMATED HOURLY EMISSION RATE (Q ^h) ^{2,6} lb/hr	SLEVs/Q ^h RATIO
				µg/m ³	g/sec	g/sec	lb/hr		
1	2	3	4	5	6	7	8	9	
NONCARCINOGENIC POLLUTANTS									
1	2-Butoxyethanol	111-76-2	120,000	1,200	4.78	38.0	0.0327	1,160.0	
2	Isobutyl Acetate	110-19-0	700,000	7,000	27.9	221.0	0.114	1,940.0	
3	Isopropyl Alcohol	67-63-0	980,000	9,800	39.1	310.0	0.0653	4,740.0	
4	Particulate Matter, Respirable Dust ^{3,4,5}	NA	3,000	30.0	0.120	0.949	0.00805	118.0	
5	Toluene	108-88-3	188,000	1,880	7.49	59.5	0.0758	785.0	
6	Trimethyl Benzene	25551-13-7	125,000	1,250	4.98	39.5	0.0431	918.0	
7	Xylene (o-,m-,p-Isomers)	1330-20-7	434,000	4,340	17.3	137.0	0.259	531.0	
CARCINOGENIC POLLUTANTS									
8	Benzene	71-43-2	32,000	320	1.28	10.0	0.000862	11,700.0	

TABLE C.—8-Hour SLEV/Q Ratios of the Toxic (Noncarcinogenic and Carcinogenic) Air Pollutants from TA-3-38 Paint Booth¹-Continued

Site Operations Data:

- The amount of oil-based paint used annually is 10 gal./year.
- The constituents of the paint are toluene (5% by weight), trimethyl benzene (5% by weight), xylene (30% by weight), and benzene (0.1% by weight).
- The highest density of the paint is 9.1 lb/gal.
- The amount of paint thinner used annually with a density of 6.9 lb/gal. is 5 gal.
- The constituents of the thinner are toluene (10% by weight), isopropyl alcohol (20% by weight), 2-Butoxyethanol (10% by weight), and isobutyl acetate (35% by weight).

Notes:

Major Assumptions:

- 1 Type and duration of painting operations conducted at TA-60-17 in 1994 (528 hours of operation consisted of 240 hours/year of rack painting, plus 288 hours/year of maintenance painting) would apply to all painting activities conducted at TA-3-39 paint booth.
- 2 Hourly emission rates were estimated based upon 528 hours/year of operation using a correction factor of five to approximate the maximum potential hourly emission rate.
- 3 Particulate emissions of 10 micrometers in size (PM₁₀) were estimated based upon the solids content of a paint and amount of total particulates emitted from TA-3-38 paint booth (844 lb/year).
- 4 Content of fine particles PM₁₀ is 50% of the total particulate matter content.
- 5 5% of the PM₁₀ content would be released into the atmosphere.
- 6 The constituents of the paint and the thinner used at TA-3-39 paint booth are the same as for the paint booth at TA-3-38.

Guideline Value(s):

- 7 OEL = occupational exposure limits established by the American Conference of Governmental Industrial Hygienists (ACGIH 1997).

- 8 1/100 of the OEL is 8-hour guideline value used in the analysis to estimate short-term impacts of the toxic air pollutants.

Dispersion Analysis Results:

- 9 5 years of meteorological data were used in the dispersion modeling analysis. The highest ISC-3 estimated 8-hour concentration at fence line receptors was found to be 250.9 µg/m³ when emission rate is 1 g/sec.

TABLE D.—Annual SLEV/Q Ratios of the Carcinogenic Pollutants from TA-3-38 Paint Booth

NO.	CARCINOGENIC POLLUTANT	CAS NUMBER	CAR. CLASS	UNIT RISK FACTOR (URF) ($\mu\text{g}/\text{m}^3\text{-}1$)	MAXIMUM CANCER RISK ($C_{\text{an}} \times \text{URF}$) ⁴	ANNUAL SLEV ¹		ESTIMATED ANNUAL EMISSION RATE (Q ^a) ^{2,3}	SLEV/Q ^a RATIO
						g/sec	lb/year		
1	2	3	4	5	6	7	8	9	10
1	Benzene	71-43-2	A	8.30E-06	1.59E-05	6.28E-04	2.63E+00	9.10E-02	2.89E+01

Site Operations Data:

- The amount of oil-based paint used annually is 10 gal./year.
- The highest density of the paint is 9.1 lb/gal.

Notes:

Major Assumptions:

- ¹ Type and duration of painting operations conducted at TA-60-17 in 1994 (528 hours of operation consisted of 240 hours/year of rack painting, plus 288 hours/year of maintenance painting) would apply to all painting activities conducted at TA-3-39 paint booth.
- ² Emission rate was estimated based upon amount of paint used annually and benzene content of the paint.
- ³ The benzene content of the paint is the same as for the paint booth at TA-3-38 (0.1% by weight).

Dispersion Analysis Results:

- ⁴ 5 years of meteorological data were used in the dispersion modeling analysis. The highest ISC-3 estimated annual concentration at sensitive receptors was found to be 1.92 $\mu\text{g}/\text{m}^3$ when emission rate is 1 g/sec.

TABLE E.—8-Hour SLEV/Q Ratios of the Toxic (Noncarcinogenic and Carcinogenic) Air Pollutants from TA-60-17 Paint Booth¹

NO.	TOXIC AIR POLLUTANTS	CAS NUMBER	OEI ⁷	1/100 OF THE OEI ⁸	8-HR SLEV ⁹		ESTIMATED HOURLY EMISSION RATE (Q ^h) ^{2,6}	SLEVs/Q ^h RATIO
			µg/m ³	µg/m ³	g/sec	lb/hr		
1	2	3	4	5	6	7	8	9
NONCARCINOGENIC POLLUTANTS								
1	2-Butoxyethanol	111-76-2	120,000	1,200	8.46	67.1	0.288	233.0
2	Isobutyl Acetate	110-19-0	700,000	7,000	49.3	392.0	1.01	389.0
3	Isopropyl Alcohol	67-63-0	980,000	9,800	69.1	548.0	0.575	953.0
4	Particulate Matter, Respirable Dust ^{3,4,5}	NA	3,000	30.0	0.211	1.68	0.106	15.9
5	Toluene	108-88-3	188,000	1,880	13.3	105.0	0.856	123.0
6	Trimethyl Benzene	25551-13-7	125,000	1,250	8.81	69.9	0.569	123.0
7	Xylene (o-,m-,p-Isomers)	1330-20-7	434,000	4,340	30.6	243.0	3.41	71.1
CARCINOGENIC POLLUTANTS								
8	Benzene	71-43-2	32,000	320	2.26	17.9	0.114	1,570.0

TABLE E.—8-Hour SLEV/Q Ratios of the Toxic (Noncarcinogenic and Carcinogenic) Air Pollutants from TA-60-17 Paint Booth¹-Continued

Site Operations Data:

- The amount of oil-based paint used annually is 132 gal./year.
- The constituents of the paint are toluene (5% by weight), trimethyl benzene (5% by weight), xylene (30% by weight), and benzene (0.1% by weight).
- The highest density of the paint is 9.1 lb/gal.
- The amount of paint thinner used annually with a density of 6.9 lb/gal. is 44 gal.
- The constituents of the thinner are toluene (10% by weight), isopropyl alcohol (20% by weight), 2-Butoxyethanol (10% by weight), and isobutyl acetate (35% by weight).

Notes:

Major Assumptions:

- 1 Type and duration of painting operations conducted at TA-60-17 in 1994 (528 hours of operation consisted of 240 hours/year of rack painting, plus 288 hours/year of maintenance painting) would apply to all current painting activities.
 - 2 Hourly emission rates were estimated based upon 528 hours/year of operation using a correction factor of five to approximate the maximum potential hourly emission rate.
 - 3 Particulate emissions of 10 micrometers in size (PM₁₀) were estimated based upon the solids content of a paint and amount of total particulates emitted from TA-3-38 paint booth (844 lb/year).
 - 4 Content of fine particles PM₁₀ is 50% of the total particulate matter content.
 - 5 5% of the PM₁₀ content would be released into the atmosphere.
 - 6 The constituents of the paint and the thinner used at TA-60-17 paint booth are the same as for the paint booth at TA-3-38.
 - 7 OEL = occupational exposure limits established by the American Conference of Governmental Industrial Hygienists (ACGIH 1997).
Guideline Value(s):
 - 8 1/100 of the OEL is 8-hour guideline value used in the analysis to estimate short-term impacts of the toxic air pollutants.
- Dispersion Analysis Results:
- 9 5 years of meteorological data were used in the dispersion modeling analysis. The highest ISC-3 estimated 8-hour concentration at fence line receptors was found to be 141.9 µg/m³ when emission rate is 1 g/sec.

TABLE F.—Annual SLEV/Q Ratios of the Carcinogenic Pollutants from TA-60-17 Paint Booth

NO.	CARCINOGENIC POLLUTANT	CAS NUMBER	CAR. CLASS	UNIT RISK FACTOR (URF) ($\mu\text{g}/\text{m}^3$) ⁻¹	MAXIMUM CANCER RISK ($C_{\text{an}} \times \text{URF}$) ⁴	ANNUAL SLEV ¹		ESTIMATED ANNUAL EMISSION RATE (Q) ^{2,3}	SLEV/Q ^a RATIO
						g/sec	lb/year		
1	2	3	4	5	6	7	8	9	10
1	Benzene	71-43-2	A	8.30E-06	4.03E-05	2.48E-04	1.04E+00	1.20E+00	8.66E-01

Site Operations Data:

- The amount of oil-based paint used annually is 132 gal./year.
- The highest density of the paint is 9.1 lb/gal.

Notes:

Major Assumptions:

- ¹ Type and duration of painting operations conducted at TA-60-17 in 1994 (528 hours of operation consisted of 240 hours/year of rack painting, plus 288 hours/year of maintenance painting) would apply to all current painting activities.
 - ² Emission rate was estimated based upon amount of paint used annually and benzene content of the paint.
 - ³ The benzene content of the paint is the same as for the paint booth at TA-3-38 (0.1% by weight).
- Dispersion Analysis Results:
- ⁴ 5 years of meteorological data were used in the dispersion modeling analysis. The highest ISC-3 estimated annual concentration at sensitive receptors was found to be 4.85 $\mu\text{g}/\text{m}^3$ when emission rate is 1 g/sec.

ATTACHMENT 11

AIR QUALITY IMPACT ASSESSMENT OF INCINERATOR EMISSIONS

Technical Area: TA-16

Emission Source(s): Incineration of HE-Contaminated Paper and Oil

Two incinerator impact analyses were conducted, one for burning high explosives (HE)-contaminated paper waste and one for burning HE-contaminated oil.

Incineration of HE-Contaminated Paper Waste

Maximum Firing Rate

The maximum HE-contaminated paper waste firing rate was estimated to be 2,204.6 pounds (1,000 kilograms) per year in order to reflect the maximum amount of paper waste currently burned under baseline conditions and the expected maximum amount that is anticipated to be burned under any of the future alternatives.

Source Term Parameters (from incinerator specifications)

- Incinerator stack height above ground level = 28.15 feet (8.58 meters)
- Stack inner diameter = 1.83 feet (0.559 meters)
- Stack exit velocity = 22.97 feet per second (7 meters per second) (assumed based on engineering judgment)
- Stack exit temperature = 800°F (427°C) (assumed based on engineering judgment)
- Stack location = south-east corner of Building 1409 of TA-16

Pollutant(s) Considered

Pollutants usually associated with the combustion of paper and wood waste are metals, acid gases, toxic organics such as CDD/CDF (i.e., groups of chlorinated homologs of dioxins and furans), and criteria pollutants (CO, NO_x, SO₂, and PM₁₀). For conservativeness, only toxic pollutants with the highest toxicity and carcinogenicity, such as arsenic, hexavalent chromium, cadmium, nickel, and CDD/CDF were selected for evaluation.

Emission Rates of Pollutants Considered

Emission factors for toxic and criteria pollutants considered were obtained from EPA's "Compilation of Air Pollutant Emissions Factors" (EPA 1995) (Table 2.1-9) for modular starved air combustors burning solid waste. Emission factors for criteria pollutants were used for estimating long-term emission rates because they are based only on long-term monitoring data.

Estimated annual emission rates of the toxic and criteria pollutants that are based on the most recent AP-42 emission factors are shown in Tables A and B, respectively.

Major Assumptions

- Incinerator would operate 250 hours a year (one burn per day, 5 days per week, and 50 weeks per year).
- 30 percent of the total chromium would be released in the form of hexavalent chromium.
- Emissions would be released over 8,760 hours of operation per year.
- The content of fine particulates (less than 10 micrometers in size) is 50 percent of the total particulate matter emitted.

Results

Toxic Air Pollutants. Because all of the toxic pollutants to be considered in the analysis are carcinogenic and annual impacts from these pollutants on ambient air are much more significant than the short-term (8-hour) impacts, only annual impacts were considered. As shown in Table A, only one of the pollutants considered (CDD/CDF) had an estimated pollutant level greater than the established Guideline Value (GV) (i.e., the SLEV/Q^a ratio is less than 1). This pollutant will therefore be further evaluated as a part of the additive impact analysis. None of the releases of other toxic pollutants would result in air quality impacts.

Criteria Air Pollutants. As shown in Table C, estimated annual concentrations of the criteria pollutants (C^{an}) are below the NAAQS. That is, the NAAQS/C^{an} ratios are always greater than 1. None of the releases of criteria pollutants would result in air quality impacts.

Incineration of HE-Contaminated Oil

Maximum Firing Rate

The maximum HE-contaminated oil firing rate is 1,200 gallons (4,542.48 liters) annually and 10 gallons (37.85 liters) hourly.

Source Term Parameters

The source term parameters are the same as were used in the analysis of HE-contaminated paper waste.

Pollutant(s) Considered

HE-contaminated oil generated by the High Explosives Processing Facility (HEPF) is not a “traditional waste oil,” and many of the toxic air pollutants (such as metals) are not constituents of HE-contaminated oil. Therefore, metals were not considered in this analysis. The composition of VOCs were determined using EPA data (EPA 1995). Based on these data, it was assumed that, with the exception of metals, some specified organic compounds from VOCs, such as phenol, dichlorobenzene, naphthalene, and benzo(p)pyrene, may be formed as products of incomplete combustion. There also

are acid gases, such as hydrogen chloride that are usually detected in flue gases from waste oil combustion. Based on these findings, toxic pollutants from waste oil burning were considered.

Emission Rates of Pollutants Considered

Emission factors for toxic and criteria air pollutants were obtained from Tables 1.11-1, -2, -3, and -5 of EPA 1995 for waste oil combustors. Estimated maximum hourly emission rates of the toxic noncarcinogenic and criteria air pollutants are presented in Table D. Estimated annual emission rates of the toxic carcinogenic pollutants and criteria pollutants are shown in Tables E and F, respectively.

Major Assumptions

- Incinerator would operate 250 hours a year (one burn per day, 5 days per week, and 50 weeks per year).
- Emissions would be released over 8,760 hours of operation per year.
- Percent of chlorine in oil is 0.1 percent by weight.
- Percent of ash in oil is 1 percent by weight.
- Sulfur content in oil is 1 percent by weight.

Results

Toxic Air Pollutants. Both short-term (8-hour) and long-term (annual) impacts of the toxic (carcinogenic and noncarcinogenic) air pollutants from waste oil incineration were considered. No pollutants failed the analysis (i.e., the estimated pollutant levels are below the established GV). As shown in Tables D and E, the SLEV/Q ratios are always greater than 1. None of the releases of toxic pollutants would result in air quality impacts.

Criteria Air Pollutants. As shown in Table G, estimated annual concentrations of the criteria pollutants (C^{an}) are below the NAAQS (i.e., the NAAQS/ C^{an} ratios are always greater than 1). None of the releases of criteria pollutants would result in air quality impacts.

TABLE A.—Annual SLEV/Q Ratios for the Toxic Carcinogenic Air Pollutants from TA–16 Incinerator Burning HE-Contaminated Paper Waste

NO.	CARCINOGENIC AIR POLLUTANT	CAS NUMBER	CAR CLASS	UNIT RISK FACTOR (URF) ($\mu\text{g}/\text{m}^3\text{-}1$)	MAXIMUM CANCER RISK ($C_{\text{an}} \times \text{URF}$) ⁵	ANNUAL SLEVs ³		EMISSION FACTORS ¹	ANNUAL AVERAGE EMISSION RATES (Q^a) ²	SLEV/Q ^a RATIO
						g/sec	lb/year			
1	2	3	4	5	6	7	8	9	10	11
1	Arsenic, el. & inorg., exc. Arsine, as As	7440-38-2	A	4.30E-03	1.57E-03	6.38E-06	1.27E-02	6.69E-04	7.37E-04	1.72E+01
2	Cadmium, el. & compounds, as Cd	7440-43-9	B1	1.80E-03	6.56E-04	1.53E-05	3.03E-02	2.41E-03	2.66E-03	1.14E+01
3	Chromium (VI) ⁴	18540-29-9	A	1.20E-02	4.37E-03	2.29E-06	4.54E-03	3.31E-03	1.09E-03	4.15E+00
4	Nickel, metal (dust)	NA	A	2.40E-04	8.74E-05	1.14E-04	2.27E-01	5.52E-03	6.08E-03	3.37E+01
5	2,3,7,8-Tetrachlorodibenzo(p)dioxin (CDD/CDF)	1746-01-6	B2	3.30E+01	1.20E+01	8.32E-10	1.65E-06	2.94E-06	3.24E-06	5.09E-01

Source Term Parameters:

Source term parameters obtained from incinerator specification were as follows:

- Incinerator stack height above ground level is 8.58 m.
- Stack inner diameter is 0.559 m.
- Stack exit velocity is 7 m/sec (assumed).
- Stack exit temperature is 427°C.
- Stack location is southeast corner of Building 1409 of TA–16.

Maximum Firing Emission Rate:

Maximum amount of the material burned is 1,000 kilograms on an annual basis.

Notes:

Major Assumptions:

- ¹ Emission factors were obtained from EPA's AP-42 (EPA 1995), Tables 2.1–9 for modular starved air combustors burning solid waste.
- ² Annual average emission rates were estimated based on EPA's AP-42 emission factors and the maximum amount of material burned annually (EPA 1995).
- ³ Annual SLEVs (lb/yr) were estimated assuming that incinerator would be operating 250 hours/year (one burn/day, 5 days/week, and 50 weeks/year).
- ⁴ 30% of the total chromium was assumed to be released in the form of hexavalent chromium.

Dispersion Analysis Results:

5 5 years of meteorological data (1991 to 1995) were used in the dispersion modeling analysis. The highest annual concentration of 0.36 $\mu\text{g}/\text{m}^3$ was found to occur during 1991.

TABLE B.—Annual Emission Rates for the Criteria Pollutants from TA-16 Incinerator Burning HE-Contaminated Paper Waste

NO.	CRITERIA AIR POLLUTANTS	AMOUNT OF WASTE BURNED ANNUALLY ^a		EPA'S AP-42 EMISSION FACTORS ^b		ANNUAL EMISSION RATE ^c				
		lb/year	5	lb/ton	3	lb/lb	4	lb/year	6	g/sec
1	Particulate Matter (PM ₁₀) ^d	2.20E+03	3.43E+00	1.72E-03	1.89E+00	2.72E-05	1.89E+00	2.72E-05	5.01E-05	5.13E-05
2	Nitrogen Oxide	2.20E+03	3.16E+00	1.58E-03	3.48E+00	5.01E-05	3.48E+00	5.01E-05	5.13E-05	5.13E-05
3	Sulfur Dioxide	2.20E+03	3.23E+00	1.62E-03	3.56E+00	5.13E-05	3.56E+00	5.13E-05	5.13E-05	5.13E-05

Notes:

Maximum Firing Annual Emission Rate:

^a Maximum amount of material burned is 1,000 kilograms on an annual basis.

Major Assumptions:

^b Emission factors for criteria pollutants were obtained from EPA's AP-42 (EPA 1995), Tables 2.1-9 for modular starved air combustors burning solid waste. These emission factors are intended to be used for estimating long-term emission levels only.

^c Annual average emission rates were estimated based on EPA's AP-42 emission factors, maximum amount of material burned annually, and assumption that the emissions would be released over 8,760 hours of operation per year (EPA 1995).

^d The fraction of fine particulates (PM₁₀) is 50% of the total particulate matter.

TABLE C.—Annual Impact Analysis of the Criteria Pollutants from TA-16 Incinerator Burning HE-Contaminated Paper Waste

NO.	CRITERIA AIR POLLUTANTS	AVERAGING TIME PERIOD	ANNUAL EMISSION RATE ^a	ICS-3 ESTIMATED ANNUAL POLLUTANT CONCENTRATION (C ^{an}) ^b	NATIONAL AMBIENT AIR QUALITY STANDARD (NAAQS)	(NAAQS)/(C ^{an}) RATIO
1	2	3	4	5	6	7
1	Particulate Matter (PM ₁₀)	Annual	2.72E-05	1.00E-05	50	5.00E+06
2	Nitrogen Oxide	Annual	5.01E-05	2.00E-05	100	5.00E+06
3	Sulfur Dioxide	Annual	5.13E-05	2.00E-05	80	4.00E+06

Source Term Parameters:

Source term parameters obtained from incinerator specification were as follows:

- Incinerator stack height above ground level is 8.58 m.
- Stack inner diameter is 0.559 m.
- Stack exit velocity is 7 m/sec (assumed).
- Stack exit temperature is 427°C (assumed).
- Stack location is southeast corner of Building 1409 of TA-16.

Notes:

Annual Emission Rate:

^a As presented in Table B, item 3.

Dispersion Analysis Results:

^b 5 years of meteorological data (1991 to 1995) were used in the dispersion modeling analysis. The highest ISC-3 estimated annual concentration (C^{an}) was found to occur during 1991.

TABLE D.—8-Hour SLEV/Q Ratios for the Toxic and Criteria Air Pollutants from TA-16 Incinerator Burning HE-Contaminated Oil

NO.	TOXIC AND CRITERIA AIR POLLUTANTS	CAS NUMBER	OELs		1/100 OF THE OELs		8-HR SLEV ^s ^f		EMISSION FACTORS ^a	MAXIMUM HOURLY EMISSION RATE (Q ^h) ^e	SLEVs/Q ^h RATIO
			µg/m ³	µg/m ³	µg/m ³	µg/m ³	g/sec	lb/hr			
1	2	3	4	5	6	7	8	10	11		
TOXIC POLLUTANTS											
1	Hydrogen Chloride ^b	7647-01-0	7,000	70	5.91E-01	4.69E+00	6.60E-03	6.60E-02	7.11E+01		
2	o-Dichlorobenzene	95-50-1	300,000	3,000	2.53E+01	2.01E+02	6.70E-09	6.70E-08	3.00E+09		
3	Naphthalene	91-20-3	52,000	520	4.39E+00	3.48E+01	1.30E-05	1.30E-04	2.68E+05		
4	Phenol	108-95-2	19,000	190	1.60E+00	1.27E+01	2.40E-06	2.40E-05	5.30E+05		
CRITERIA POLLUTANTS											
5	Carbon Monoxide	638-08-1	29,000	290	2.45E+00	1.94E+01	5.00E-03	5.00E-02	3.89E+02		
6	Nitrogen Dioxide	10102-44-0	5,600	56	4.73E-01	3.75E+00	1.90E-02	1.90E-01	1.98E+01		
7	Particulate Matter (PM ₁₀) ^c	NA	3000	30	2.53E-01	2.01E+00	5.10E-02	5.10E-01	3.94E+00		
8	Sulfur Dioxide ^d	7446-09-5	5,200	52	4.39E-01	3.48E+00	1.47E-01	1.47E+00	2.37E+00		

NA = Not applicable
 Source Term Parameters:
 Source term parameters obtained from incinerator specification were as follows:
 • Incinerator stack height above ground level is 8.58 m.
 • Stack inner diameter is .559 m.
 • Stack exit velocity is 7 m/sec (assumed).
 • Stack exit temperature is 427°C (assumed).
 • Stack location is southeast corner of Building 1409 of TA-16.

TABLE D.—8-Hour SLEV/Q Ratios for the Toxic and Criteria Air Pollutants from TA-16 Incinerator Burning HE-Contaminated Oil-Continued

Maximum Firing Emission Rate:

Maximum amount of oil burned (i.e., 10 gallons on an hourly basis) was obtained from EPA 1992f.

Notes:

Major Assumptions:

- ^a Emission factors were obtained from EPA's AP-42, Tables 1.11-1, 2, 3, and 5 for waste oil combustors (EPA 1995). Toxic metal compounds such as arsenic, cadmium, chromium, etc., that are usually emitted from waste oil combustion, are not constituents of HE-contaminated oil. Therefore, toxic metals were not considered.
- ^b Percent of chlorine in oil is 0.1% by weight,
- ^c Percent of ash in oil is 1% by weight, and
- ^d Sulfur content in oil is 1% by weight.
- ^e Maximum hourly emission rates were estimated based on EPA's AP-42 emission factors and maximum amount of oil burned (EPA 1995).

Dispersion Analysis Results:

- ^f 5 years of meteorological data (1991 to 1995) were used in the dispersion modeling analysis. The estimated maximum 8-hour concentration of 118.4 $\mu\text{g}/\text{m}^3$ was found to occur during 1992.

TABLE E.—Annual SLEV/Q for the Toxic Carcinogenic Air Pollutants from TA-16 Incinerator Burning HE-Contaminated Oil

NO	TOXIC CARCINOGENIC AIR POLLUTANTS	CAS NUMBER	CAR CLASS	UNIT RISK FACTOR (URF) ($\mu\text{g}/\text{m}^3\text{-}1$)	MAXIMUM CANCER RISK ($C_{\text{an}} \times \text{URF}$) ^e	ANNUAL SLEVs ^d		EMISSION FACTORS ^b lb/gal.	AMOUNT OF OIL BURNED ON ANNUAL BASIS ^a gal./year	ANNUAL EMISSION RATE (Q _a) ^c lb/year	SLEVs/Q _a RATIO
						g/sec	lb/year				
1	2	3	4	5	6	7	8	9	10	11	12
1	Benzo(a)pyrene	50-32-8	B2	1.70E-03	6.19E-04	1.62E-05	3.20E-02	4.00E-06	1.20E+03	4.80E-03	6.68E+00

Source Term Parameters:

Source term parameters obtained from incinerator specification were as follows:

- Incinerator stack height above ground level is 8.58 m.
- Stack inner diameter is 0.559 m.
- Stack exit velocity is 7 m/sec (assumed).
- Stack exit temperature is 427°C (assumed).
- Stack location is southeast corner of Building 1409 of TA-16.

Notes:

Maximum Firing Emission Rate:

^a Maximum amount of oil burned (i.e., 1,200 gallons on an annual basis) was obtained from EPA 1992c.

Major Assumptions:

^b Emission factors for benzo(p)pyrene were obtained from EPA's AP-42, Table 1.11-5 for waste oil combustors (EPA 1995).

^c Annual average emission rate was estimated based on EPA's AP-42 (EPA 1995) emission factors and the maximum amount of oil burned annually (1,200 gallons), according to EPA 1992c.

^d Annual SLEVs was estimated assuming that incinerator would be operating 250 hours/year (one burn/day, 5 days/week, and 50 weeks/year), according to EPA 1992f.

Dispersion Analysis Results:

^e 5 years of meteorological data were used in the dispersion modeling analysis. The highest annual concentration of 0.36 $\mu\text{g}/\text{m}^3$ was found to occur during 1991.

TABLE F.—Annual Emission Rates of the Criteria Pollutants from TA-16 Incinerator Burning HE-Contaminated Oil

NO.	CRITERIA AIR POLLUTANTS	AMOUNT OF OILS BURNED ON AN ANNUAL BASIS ^a		EPA'S AP-42 EMISSION FACTORS ^b	ANNUAL EMISSION RATE ^c	
		lb/year	3		lb/gal.	lb/year
1	2			4	5	6
1	Particulate Matter (PM ₁₀) ^d	1.20E+03		5.10E-02	6.12E+01	8.81E-04
2	Nitrogen Oxide	1.20E+03		1.90E-02	2.28E+01	3.28E-04
3	Sulfur Dioxide ^e	1.20E+03		1.47E-01	1.76E+02	2.54E-03

Notes:

Maximum Firing Annual Emission Rate:

^a The maximum amount of oil burned (i.e., 1,200 gallons on an annual basis) was obtained from Table K of EPA 1992c.

Major Assumptions:

^b Emission factors for air pollutants considered in the analysis (lb/gal.) were obtained from EPA's AP-42, Table 2.1-9 for waste oil combustors (EPA 1995).^c Annual average emission rates were estimated based on EPA's AP-42 emission factors, maximum amount of material burned annually, and assumption that the emissions would be released over 8,760 hours of operation per year (EPA 1995).^d Percent of the ash in oils is 1% by weight.^e Sulfur content in oil is 1% by weight.

TABLE G.—Annual Impact Analysis of the Criteria Pollutants from TA-16 Incinerator Burning HE-Contaminated Oil

NO.	CRITERIA AIR POLLUTANTS	AVERAGING TIME PERIOD	ANNUAL EMISSION RATE ^a	ICS-3 ESTIMATED ANNUAL POLLUTANT CONCENTRATION (C ^{an}) ^b	NATIONAL AMBIENT AIR QUALITY STANDARDS (NAAQS)	(NAAQS)/(C ^{an}) RATIO
			g/sec	µg/m ³	µg/m ³	
1	2	3	4	5	6	7
1	Particulate Matter (PM ₁₀)	Annual	8.81E-04	3.19E-04	50	1.57E+05
2	Nitrogen Oxide	Annual	3.28E-04	1.20E-04	100	8.33E+05
3	Sulfur Dioxide	Annual	2.54E-03	9.30E-04	80	8.60E+04

Source Term Parameters:

Source term parameters obtained from incinerator specification were as follows:

- Incinerator stack height above ground level is 8.58 m.
- Stack inner diameter is 0.559 m.
- Stack exit velocity is 7 m/sec (assumed).
- Stack exit temperature is 427°C (assumed).
- Stack location is southeast corner of Building 1409 of TA-16.

Notes:

Annual Emission Rate:

^a As presented in Table F, item 3.

Dispersion Analysis Results:

^b 5 years of meteorological data (1991 to 1995) were used in the dispersion modeling analysis. The highest ISC-3 estimated annual concentration (C^{an}) was found to occur during 1991.

ATTACHMENT 12

AIR QUALITY IMPACT ASSESSMENT OF OPEN BURNING OPERATIONS AT HIGH EXPLOSIVES TREATMENT AND DISPOSAL FACILITY

Technical Area: TA-16

Emission Source: Open Burning Operations at High Explosives Treatment and Disposal Facility

There are three open burning emission sources at the High Explosive Processing Facilities (HEPF). These are all located at TA-16, High Explosives Treatment and Disposal Facility, and include the open burning of HE-contaminated solvents and oil, the open burning of scrap HE, and the flashing of HE-contaminated materials that cannot be burned.

Open Burning of HE-Contaminated Solvents and Oil at the Burn Pit Located at TA-16-394

Pollutant(s) Considered

There are two groups of emissions from open-burning operations of solvents and oil. These include toxic pollutants specified as volatile organics/hazardous air pollutants (VOC/HAP), and criteria pollutants—primarily carbon monoxide and PM₁₀. There are no significant NO_x emissions as a result of these activities because the relatively low temperatures associated with open burning suppress emissions of NO_x.

According to Tewerson (1985), some of the highly volatile chemicals associated with the burning solvents or oil include acetone, cyclohexane, ethanol, ethyl acetate, methyl alcohol, methyl ethyl ketone, butyl acetate, and toluene. These chemicals were therefore selected for evaluation.

Emission Rates of Pollutants Considered

Appropriate emission factors and fuel constituents were obtained from Tewerson (1985). The maximum amount of solvents and oil in a burn of 300 gallons (1,135.62 liters) and 1,200 gallons (4,542.48 liters) per year, respectively, was obtained from site data. Based on these values, the density of the fuel, and the assumption that the facility will operate 50 hours per year, an hourly emission rates of toxic and criteria air pollutants were estimated. They are presented in Tables A and B, respectively.

Major Assumptions

- 50 hours of burn operations a year (50 burns per year at 1-hour length of burn).
- Content of fine particulates (less than 10 micrometers in size) is 50 percent of the total particulate matter content.
- Emissions were modeled as surface-based volume sources using the EPA's ISC-3 Model with initial dispersion parameters estimated based on approximate burn tray dimensions.

- Following the conservative technique used for estimating short-term impacts from all emission sources, all fence line receptor locations, regardless of whether the public has access to these locations, were considered.
- Actual receptors will be considered for those sources where potential air quality impacts are likely to occur.

Results

Toxic Air Pollutants. Analysis of short-term (8-hour) impacts of the individual components comprising VOC/HAP emissions were considered at nearby fence line receptors. The analysis shows no impacts on ambient air quality; the SLEV/Q^h ratios are all greater than one (Tables C and D). That is, the estimated pollutant levels are below the established Guideline Values (GVs).

Criteria Air Pollutants. Two analyses were performed to estimate 8-hour SLEVs from open burning of HE-contaminated solvents and oil at the burn pit at TA-16-394.

Because potential impacts were predicted at all fence line receptors, including locations to which the public does not have access, the locations where the public does have access were considered. These locations are along the south border of TA-16 near State Road 4, bordering Bandelier National Monument, at 5,905.8 to 6,562 feet (1,800 to 2,000 meters) from the emission source. At these locations, the estimated 8-hour SLEV/Q^h ratios were all greater than one (Tables E and F).

Annual impacts of criteria pollutants from open burning of HE-contaminated solvents and oil at the burn pit at TA-16-394 were not considered due to the fact that the annual estimated emission rates (Tewerson 1985, Tables E and F) were too small to cause impacts.

Open Burning of Scrap HE at the Burn Pit Located at TA-16-388

Pollutant(s) Considered

The chemical constituents were selected for analysis based on information provided by Carter (1978). Due to uncertainty in identifying these constituents and their amounts in the scrap HE, chemicals of different toxicities were selected to represent the range of toxic emissions that may be emitted. These include hydrogen chloride, hydrogen fluoride, ammonia, ethanol, methyl alcohol, and acetylene.

Emission Rates of Pollutants Considered

Appropriate emission factors for selected VOC/HAP constituents were obtained from Table 3-5 of a document entitled "Air Emissions from Burning of Explosives" (Carter 1978). The maximum total amount of scrap HE burned per year, 106,526 pounds (48,320 kilograms), and the total estimated amount of VOC/HAP emissions per year (257 pounds [116.57 kilograms]) were obtained from site data. In order to estimate emissions associated with the burning of individual VOC/HAP components, it was assumed that the content of explosive components in scrap material is 1 percent. The major combustible components in scrap that account for at least 90 percent of composition are usually lumber or wood pallets. Estimated hourly and annual emission rates of toxic VOC/HAP pollutants, with the corresponding emission factors, are presented in Table G.

Major Assumptions

- The same assumptions that were used in the analysis of open-burning HE-contaminated solvents and oil at the Burn Pit Located at TA-16-394 are also made for this analysis.
- The content of explosive components in scrap material is 1 percent by weight.
- Emissions would be released over 8,760 hours of operations per year.

Results

Toxic Air Pollutants. Two analyses were performed to estimate 8-hour SLEVs of the toxic pollutants from open burning of scrap HE. Because potential impacts were predicted at fence line receptors to which the public does not have access, the locations where the public does have access were considered. The highest estimated 8-hour SLEV/Q ratios at receptor locations along the south border of TA-16 near State Road 4, bordering Bandelier National Monument, were found to be greater than one for all pollutants considered (Table H). That is, the estimated pollutant levels are below the established GV.

Annual impact analysis of toxic air pollutants from burning of HE scrap was performed at the sensitive receptor locations. Two toxic air pollutants for which inhalation reference concentrations (RfC) have been established were considered: hydrogen chloride and ammonia. The SLEV/Q^{an} ratios were found to be greater than 1 for these toxic air pollutants (Table I). That is, the estimated pollutant levels are below the established GV. None of the releases of toxic pollutants would result in air quality impacts.

Criteria Pollutants. The same methodology that was used to estimate potential annual impact of the toxic air pollutants was utilized to evaluate annual impacts of criteria pollutants. Three criteria pollutants were considered in the analysis, PM₁₀, CO, and NO₂. Annual emission rates for these pollutants were obtained directly from site data. The NAAQS/Q^{an} ratios were greater than one for all pollutants (Table J). That is, the estimated pollutant levels are below the NAAQS.

Annual impacts of criteria pollutants from the flashing of unburnable HE-contaminated materials were not considered because the quantities of emissions from these operations on an annual basis are much smaller than those from scrap HE-burning operations, and were too small to cause any impacts.

TABLE A.—Emissions of HE-Contaminated Solvents from Open Burn at TA-16

NO.	FUEL CON- STITUENTS	AMOUNT OF SOLVENTS BURNED ^{b,d}		AMOUNT OF FUEL CONSTITUENTS IN BURN	TOXIC POLLUTANTS		CRITERIA POLLUTANTS			
		gal./hr	lb/hr		YIELD OF COMPOUND ^c	HOURLY EMISSION RATE ^a	CARBON MONOXIDE		PARTICULATE MATTER (PM ₁₀) ^e	
							lb/lb	lb/hr	YIELD OF COMPOUND ^c	HOURLY EMISSION RATE ^a
1	2	3	4	5	6	7	8	9	10	11
1	Acetone	6.0	41.3	0.1196	0.0130	0.0642	0.0014	0.0069	0.0137	0.0338
2	Cyclohexane	6.0	41.3	0.1179	0.0460	0.2238	0.0100	0.0486	0.0369	0.0898
3	Ethanol	6.0	41.3	0.1195	0.0050	0.0247	0.0012	0.0059	0.0110	0.0271
4	Ethyl Acetate	6.0	41.3	0.1363	0.0069	0.0388	0.0024	0.0135	0.0120	0.0337
5	Methyl Alcohol	6.0	41.3	0.1198	0.0050	0.0247	0.0009	0.0044	0.0079	0.0195
6	Methyl Ethyl Ketone	6.0	41.3	0.1220	0.0060	0.0302	0.0031	0.0156	0.0153	0.0385
7	Butyl Acetate	6.0	41.3	0.1336	0.0465	0.2563	0.0051	0.0281	0.0199	0.0548
8	Toluene	6.0	41.3	0.1313	0.1070	0.5797	0.0639	0.3462	0.1735	0.4700
	Total							0.4693		0.7673

Emission Source:

Open burning of HE-contaminated solvents was considered at the pit located at TA-16-394.

Notes:

Hourly Emission Rate:

a Hourly emission rates in pounds per hour of each compound from burning fuel constituents were estimated using applicable emission factors, fuel constituents, and its amount in a burn.

b The maximum amount of solvents in a burn of 300 gallons per year was obtained from Tewerson 1985.

c Yield of compound is expressed in lb/lb of material combusted (Carter 1978).

Major Assumptions:

d 50 hours of burn operations a year (50 burns per year at 1 hour length of burn), according to Carter 1978.

e Content of fine particles PM₁₀ (less than 10 micrometers in size) is 50% of the total particulate matter content.

TABLE B.—Emissions of HE-Contaminated Oil from Open Burning at TA-16

NO.	FUEL CON- STITUENTS	AMOUNT OF SOLVENTS BURNED ^{b,d}		AMOUNT OF FUEL CONSTITUENTS IN BURN	TOXIC POLLUTANTS		CRITERIA POLLUTANTS			
		gal./hr	lb/hr		YIELD OF COMPOUND ^c	HOURLY EMISSION RATE ^a	CARBON MONOXIDE		PARTICULATE MATTER (PM ₁₀) ^e	
							lb/lb	lb/hr	YIELD OF COMPOUND ^c	HOURLY EMISSION RATE ^a
1	2	3	4	5	6	7	8	9	10	11
1	Acetone	24.0	165.0	0.1196	0.0130	0.2566	0.0014	0.0276	0.0137	0.1352
2	Cyclohexane	24.0	165.0	0.1179	0.0460	0.8951	0.0100	0.1946	0.0369	0.3590
3	Ethanol	24.0	165.0	0.1195	0.0050	0.0986	0.0012	0.0237	0.0110	0.1085
4	Ethyl Acetate	24.0	165.0	0.1363	0.0069	0.1552	0.0024	0.0540	0.0120	0.1350
5	Methyl Alcohol	24.0	165.0	0.1198	0.0050	0.0989	0.0009	0.0178	0.0079	0.0781
6	Methyl Ethyl Ketone	24.0	165.0	0.1220	0.0060	0.1208	0.0031	0.0624	0.0153	0.1540
7	Butyl Acetate	24.0	165.0	0.1336	0.0465	1.0253	0.0051	0.1125	0.0199	0.2194
8	Toluene	24.0	165.0	0.1313	0.1070	2.3187	0.0639	1.3847	0.1735	1.8799
	Total							1.8772		3.0690

Emission Source:
Open burning of HE-contaminated solvents was considered at the pit located at TA-16-394.

Notes:
 Hourly Emission Rate:
 a Hourly emission rates in pounds per hour of each compound from burning fuel constituents were estimated using applicable emission factors, fuel constituents, and its amount in a burn.
 b The maximum amount of solvents in a burn of 300 gallons per year was obtained from Tewerson 1985.
 c Yield of compound is expressed in lb/lb of material combusted (Carter 1978).
 Major Assumptions:
 d 50 hours of burn operations a year (50 burns per year at 1 hour length of burn), according to Carter 1978.
 e Content of fine particles PM₁₀ (less than 10 micrometers in size) is 50% of the total particulate matter content.

TABLE C.—8-Hour SLEV/Q Ratios of the Toxic Air Pollutants from Open Burning of HE-Contaminated Solvents at TA-16

NO.	TOXIC AIR POLLUTANTS	CAS NUMBER	OEI ^c	1/100 OF THE OEI ^d	8-HOUR SLEV ^b		ESTIMATED HOURLY EMISSION RATE ^a (Q ^b)	SLEV/Q ^h RATIO
			$\mu\text{g}/\text{m}^3$	$\mu\text{g}/\text{m}^3$	g/sec	lb/hr		
1	2	3	4	5	6	7	8	9
1	Acetone	67-64-1	1,780,000	17,800	3.89E+01	3.09E+02	0.0642	4.81E+03
2	Cyclohexane	110-82-7	1,050,000	10,500	2.29E+01	1.82E+02	0.2238	8.13E+02
3	Ethanol	64-17-5	1,880,000	18,800	4.11E+01	3.26E+02	0.0247	1.32E+04
4	Ethyl Acetate	141-78-6	1,400,000	14,000	3.06E+01	2.43E+02	0.0388	6.25E+03
5	Methyl Alcohol	67-56-1	262,000	2,620	5.72E+00	4.54E+01	0.0247	1.84E+03
6	Methyl Ethyl Ketone	78-93-3	590,000	5,900	1.29E+01	1.02E+02	0.0302	3.39E+03
7	n-Butyl Acetate	123-86-4	710,000	7,100	1.55E+01	1.23E+02	0.2563	4.80E+02
8	Toluene	108-88-3	188,000	1,880	4.11E+00	3.26E+01	0.5797	5.62E+01

Emission Source:

Open burning of HE-contaminated solvents was considered at the pit located at TA-16-394.

Notes:

Major Assumptions:

^a Emission rates are presented in Table A. Emissions were modeled as surface-based volume source using EPA's ISC-3 Model with initial dispersion parameters estimated based on approximate tray dimensions. Initial lateral and vertical dimensions of the volume source was estimated based on the EPA Guideline, "Volume Source Inputs," EPA's User's Guide for the Industrial Source Complex (ISC-3) Dispersion Model, Volume 1 (EPA 1992b).

Dispersion Analysis Results:

^b The highest ISC-3 estimated concentration at fence line receptors was found to be 457.9 $\mu\text{g}/\text{m}^3$ when emission rate is 1 g/sec.

Guideline Values

^c OEI = occupational exposure limits established by the American Conference of Governmental Industrial Hygienists (ACGIH 1997).

^d 1/100 of the OEI is 8-hour guideline value used in the analysis to estimate short-term (8-hour) impacts of the toxic air pollutants.

TABLE D.—8-Hour SLEV/Q Ratios of the Toxic Air Pollutants from Open Burning of HE-Contaminated Oil at TA-16

NO.	TOXIC AIR POLLUTANTS	CAS NUMBER	OEL ^c µg/m ³	1/100 OF THE OEL ^d		8-HOUR SLEV ^b		ESTIMATED HOURLY EMISSION RATE ^a (Q ^b) lb/hr	SLEV/Q ^h RATIO
				µg/m ³	5	g/sec	6		
1	Acetone	67-64-1	1,780,000	17,800	3.89E+01	3.09E+02	0.2566	1.20E+03	
2	Cyclohexane	110-82-7	1,050,000	10,500	2.29E+01	1.82E+02	0.8951	2.03E+02	
3	Ethanol	64-17-5	1,880,000	18,800	4.11E+01	3.26E+02	0.0986	3.30E+03	
4	Ethyl Acetate	141-78-6	1,400,000	14,000	3.06E+01	2.43E+02	0.1552	1.56E+03	
5	Methyl Alcohol	67-56-1	262,000	2,620	5.72E+00	4.54E+01	0.0989	4.59E+02	
6	Methyl Ethyl Ketone	78-93-3	590,000	5,900	1.29E+01	1.02E+02	0.1208	8.46E+02	
7	n-Butyl Acetate	123-86-4	710,000	7,100	1.55E+01	1.23E+02	1.0253	1.20E+02	
8	Toluene	108-88-3	188,000	1,880	4.11E+00	3.26E+01	2.3187	1.41E+01	

Emission Source:

Open burning of HE-contaminated oil was considered at the pit located at TA-16-394.

Notes:

Major Assumptions:

^a Emission rates are presented in Table B. Emissions were modeled as surface-based volume source using EPA's ISC-3 Model with initial dispersion parameters estimated based on approximate tray dimensions. Initial lateral and vertical dimensions of the volume source was estimated based on the EPA Guideline, "Volume Source Inputs," EPA's User's Guide for the Industrial Source Complex (ISC-3) Dispersion Model, Volume 1 (EPA 1992b).

Dispersion Analysis Results:

^b The highest ISC-3 estimated concentration at fence line receptors was found to be 457.9 µg/m³ when emission rate is 1 g/sec.

Guideline Values

^c OEL = occupational exposure limits established by the American Conference of Governmental Industrial Hygienists (ACGIH 1997).

^d 1/100 of the OEL is 8-hour guideline value used in the analysis to estimate short-term (8-hour) impacts of the toxic air pollutants.

TABLE E.—8-Hour SLEV/Q Ratios of the Criteria Pollutants from Open Burning of HE-Contaminated Solvents at TA-16

NO.	CRITERIA AIR POLLUTANTS ^a	CAS NUMBER	OEL ^d µg/m ³	1/100 OF THE OEL ^e µg/m ³		8-HOUR SLEV ^c lb/hr		ESTIMATED HOURLY EMISSION RATE ^b (Q ^h) lb/hr	SLEV/Q ^h RATIO
				5	30	6	7		
1	2	3	4	5	6	7	8	9	
1	Particulate Matter (PM ₁₀)	NA	3,000	30	3.65	29.0	0.77	37.8	
2	Carbon Monoxide	630-08-0	29,000	290	35.3	280.0	0.47	597.0	

Emission Source:

Open burning of HE-contaminated oil was considered at the pit located at TA-16-394.

Notes:

Major Assumptions:

^a The same modeling procedure that was used to estimate the air quality impacts of toxic air pollutants that have the potential to be released from open burning operations at TA-16 under future alternatives. Two criteria pollutants (CO and PM₁₀) were considered from open burning operations of HE-contaminated oil at the burn pit located at TA-16-394. According to Tewerson 1985, there is no significant NO_x emissions as a result of these activities.

^b Emission rates are presented in Table A. Emissions were modeled as surface-based volume source using EPA's ISC-3 Model with initial dispersion parameters estimated based on approximate tray dimensions. Initial lateral and vertical dimensions of the volume source was estimated based on the EPA Guideline, "Volume Source Inputs," EPA's User's Guide for the Industrial Source Complex (ISC-3), Dispersion Model, Volume 1 (EPA 1992b).

Dispersion Analysis Results:

^c In this analysis, receptor locations to where the public could have access were considered. These are locations along the south border of TA-16 near State Road 4, bordering Bandelier National Monument. The highest ISC-3 estimated concentration at these receptor locations was found to be 8.2 µg/m³ when emission rate is 1 g/sec.

Guideline Values

^d OEL = occupational exposure limits established by the American Conference of Governmental Industrial Hygienists (ACGIH 1997).

^e 1/100 of the OEL is 8-hour guideline value used in the analysis to estimate short-term (8-hour) impacts of the toxic air pollutants.

NA = Not applicable

TABLE F.—8-Hour SLEV/Q Ratios of the Criteria Pollutants from Open Burning of HE-Contaminated Oil at TA-16

NO.	CRITERIA AIR POLLUTANTS ^a	CAS NUMBER	OEL ^d µg/m ³	1/100 OF THE OEL ^e		8-HOUR SLEV ^c		ESTIMATED HOURLY EMISSION RATE ^b (Q ^h) lb/hr	SLEV/Q ^h RATIO
				µg/m ³	5	g/sec	6		
1	2	3	4	5	6	7	8	9	
1	Particulate Matter (PM ₁₀)	NA	3,000	30	3.65	29.0	3.07	9.44	
2	Carbon Monoxide	630-08-0	29,000	290	35.3	280.0	1.88	149.0	

Emission Source:

Open burning of HE-contaminated oil was considered at the pit located at TA-16-394.

Notes:**Major Assumptions:**

^a The same modeling procedure that was used to estimate the air quality impacts of toxic air pollutants that have the potential to be released from open burning operations at TA-16 under future alternatives. Two criteria pollutants (CO and PM₁₀) were considered from open burning operations of HE-contaminated oil at the burn pit located at TA-16-394. According to Tewerson 1985, there is no significant NO_x emissions as a result of these activities.

^b Emission rates are presented in Table B. Emissions were modeled as surface-based volume source using EPA's ISC-3 Model with initial dispersion parameters estimated based on approximate tray dimensions. Initial lateral and vertical dimensions of the volume source was estimated based on the EPA Guideline, "Volume Source Inputs," EPA's User's Guide for the Industrial Source Complex (ISC-3), Dispersion Model, Volume 1 (EPA 1992b).

Dispersion Analysis Results:

^c In this analysis, receptor locations where the public could have access to were considered. These are locations along the south border of TA-16 near State Road 4, bordering Bandelier National Monument. The highest ISC-3 estimated concentration at any of these receptor locations was 8.2 µg/m³, when emission rate is 1 g/sec, and the SLEV/Q ratio was greater than 1.

Guideline Values

^d OEL = occupational exposure limits established by the American Conference of Governmental Industrial Hygienists (ACGIH 1997).

^e 1/100 of the OEL is 8-hour guideline value used in the analysis to estimate short-term (8-hour) impacts of the toxic air pollutants.

NA = Not applicable

TABLE G.—VOC/HAP Emissions from Open Burning of Scrap HE at TA-16

NO.	CONSTITUENTS ^d	AMOUNT OF SCRAP HE BURNED PER YEAR ^c		AMOUNT OF EXPLOSIVE COMPONENTS IN A BURN PRODUCING VOC/HAP ^{d,e}		EMISSION FACTORS ^b	VOC/HAP POLLUTANTS		
		kg/year	3	lb/year	4		tons/year	5	ANNUAL EMISSION RATE ^a
1	2					lb/ton	lb/year	lb/hr	
1	Hydrogen Chloride	48,320		1,065		22.9	12.2	0.24	
2	Hydrogen Fluoride	48,320		1,065		30.0	16.0	0.32	
3	Ammonia	48,320		1,065		23.9	12.7	0.25	
4	Ethanol	48,320		1,065		160.0	85.2	1.70	
5	Methyl Alcohol	48,320		1,065		99.0	52.7	1.05	
6	Acetylene	48,320		1,065		146.0	77.8	1.56	
Total							257		

Emission Source:

Open burning of scrap HE was considered at the pit located at TA-16-388.

Notes:

Annual and Hourly Emission Rates:

^a Annual and hourly emission rates of each compound from burning scrap were estimated using applicable emission factors, scrap constituents, and their amount in scrap.

^b Emission factors in lb/ton for the VOC/HAP constituents were obtained from Table 3-5 entitled, "Air Emissions From Burning of Explosives" (Carter 1978).

^c The maximum total amount of scrap HE burned per year (48,320 kilograms) and the total estimated amount of VOC/HAP emissions per year (257 pounds) was obtained from Table G of Tewerson 1985.

Major Assumptions:

^d Constituents of VOC/HAP emissions were selected based on Carter 1978. Due to uncertainty in identifying of typical composition of explosives and their amount in the scrap HE, chemicals of different toxicity were selected to represent the range of toxic emissions that may be emitted.

^e The content of explosive components in scrap is 1% by weight.

^f 50 hours of burn operations a year (50 burns per year at 1 hour length of burn).

VOC/HAP = volatile organic compound/hazardous air pollutant

TABLE H.—8-Hour SLEV/Q Ratios of the Toxic Air Pollutants from Open Burning of Scrap HE at TA-16

NO.	TOXIC AIR POLLUTANTS	CAS NUMBER	OEL ^d µg/m ³	1/100 OF THE OEL ^e		8-HOUR SLEV ^{b,c}		ESTIMATED HOURLY EMISSION RATE ^a (Q ^b) lb/hr	SLEV/Q ^h RATIO
				µg/m ³	5	g/sec	7		
1	2	3	4	5	6	7	8	9	
1	Hydrogen Chloride	7647-01-0	7,000	70	1.44E+00	1.14E+01	0.24	4.75E+01	
2	Hydrogen Fluoride	7664-39-3	2,490	25	5.11E-01	4.05E+00	0.32	1.27E+01	
3	Ammonia	7664-41-7	18,000	180	3.69E+00	2.93E+01	0.25	1.17E+02	
4	Acetylene	74-86-2	2,662,000	26,620	5.46E+02	4.33E+03	1.56	2.78E+03	
5	Ethanol	64-17-5	1,880,000	18,800	3.86E+02	3.06E+03	1.70	1.80E+03	
6	Methyl Alcohol	67-56-1	262,000	2,620	5.38E+01	4.27E+02	1.05	4.06E+02	

Emission Source:

Open burning of scrap HE was considered at the pit located at TA-16-388.

Notes:

Major Assumptions:

^a Emission rates are presented in Table G. Emissions were modeled as surface-based volume source using EPA's ISC-3 Model with initial dispersion parameters estimated based on approximate tray dimensions. Initial lateral and vertical dimensions of the volume source was estimated based on the EPA Guideline, "Volume Source Inputs," EPA's User's Guide for the Industrial Source Complex (ISC-3) Dispersion Model, Volume 1 (EPA 1992b)

Dispersion Analysis Results:

^b In this analysis, receptor locations where the public could have access to were considered. These are locations along the south border of TA-16 near State Road 4, bordering Bandelier National Monument.

^c The highest ISC-3 estimated concentration at fence line receptors was found to be 48.7 µg/m³ when emission rate is 1 g/sec. Guideline Values

^d OEL = occupational exposure limits established by the American Conference of Governmental Industrial Hygienists (ACGIH 1997).

^e 1/100 of the OEL is 8-hour guideline value used in the analysis to estimate short-term (8-hour) impacts of the toxic air pollutants.

TABLE I.—Annual SLEV/Q Ratios of the Toxic Air Pollutants from Open Burning of Scrap HE at TA-16

NO.	TOXIC AIR POLLUTANTS	CAS NUMBER	RfC ^c		ANNUAL SLEVs ^b		ESTIMATED ANNUAL EMISSION RATE ^a (Q ⁸)	SLEV/Q ⁸ RATIO
			µg/m ³	4	g/sec	lb/year		
1	2	3	4	5	6	7	8	
1	Ammonia	7664-41-7	100	1.30E+02	5.14E+04	12.7	4.05E+03	
2	Hydrogen Chloride	7647-01-0	20	2.59E+01	1.03E+04	12.2	8.43E+02	

Emission Source:

Open burning of scrap HE was considered at the pit located at TA-16-388.

Notes:

Major Assumptions:

^a Emission rates are presented in Table G. Emissions were modeled as surface-based volume source using EPA's ISC-3 Model with an initial dispersion parameters estimated based on an approximate tray dimensions. Initial lateral and vertical dimensions of the volume source was estimated based on the EPA Guideline, "Volume Source Inputs," EPA's User's Guide for the Industrial Source Complex (ISC-3) Dispersion Model, Volume 1 (EPA 1992b).

Dispersion Analysis Results:

^b The ISC-3 estimated annual concentration used to compute annual SLEV was found to be 0.77 µg/m³ at sensitive receptors when emission rate is 1 g/sec.

Guideline Value(s):

^c RfC = Inhalation reference concentrations that represent the annual guideline value(s) used in the analysis to estimate annual impacts of the toxic air pollutants.

TABLE J.—Annual SLEV/Q Ratios of the Toxic Air Pollutants from Open Burning of Scrap HE at TA-16

NO.	TOXIC AIR POLLUTANTS	CAS NUMBER	RfC ^c		ANNUAL SLEVs ^b		ESTIMATED ANNUAL EMISSION RATE ^a (Q ^a)	SLEV/Q ^a RATIO
			µg/m ³	4	g/sec	5		
1	Ammonia	7664-41-7	100	4	1.30E+02	5	12.7	4.05E+03
2	Hydrogen Chloride	7647-01-0	20	4	2.59E+01	5	12.2	8.43E+02

Emission Source:

Open burning of scrap HE was considered at the pit located at TA-16-388.

Notes:

Major Assumptions:

^a Emission rates are presented in Table G. Emissions were modeled as surface-based volume source using EPA's ISC-3 Model with an initial dispersion parameters estimated based on an approximate tray dimensions. Initial lateral and vertical dimensions of the volume source was estimated based on the EPA Guideline, "Volume Source Inputs," EPA's User's Guide for the Industrial Source Complex (ISC-3) Dispersion Model, Volume 1 (EPA 1992b).

Dispersion Analysis Results:

^b The ISC-3 estimated annual concentration used to compute annual SLEV was found to be 0.77 µg/m³ at sensitive receptors when emission rate is 1 g/sec. Guideline Value(s):

^c RfC = Inhalation reference concentrations that represent the annual guideline value(s) used in the analysis to estimate annual impacts of the toxic air pollutants.

TABLE K.—Annual Impact Analysis of the Criteria Pollutants from Open Burning of Scrap HE at TA-16-388

NO.	CRITERIA AIR POLLUTANTS	AVERAGING TIME PERIOD	ANNUAL EMISSION RATE ^{a,c}	ICS-3 ESTIMATED ANNUAL POLLUTANT CONCENTRATION (C ^{an}) ^{b,d}	NATIONAL (NAAQS)	(NAAQS)/(C ^{an}) RATIO
			g/sec	µg/m ³	µg/m ³	
1	2	3	4	5	6	7
1	Particulate Matter (PM ₁₀)	Annual	9.66E-02	7.49E-02	50	6.68E+02
2	Nitrogen Oxide	Annual	9.68E-02	7.50E-02	100	1.33E+03
3	Carbon Monoxide	Annual	3.73E-02	2.89E-02	80	2.77E+03

Emission Source:

Open burning of scrap HE was considered at the pit located at TA-16-388.

Notes:

Major Assumptions:

^a Annual emission rates were estimated based on information provided in Table G of Tewerson 1985.

^b Emissions were modeled as surface-based volume source using EPA's ISC-3 Model with initial dispersion parameters estimated based on approximate tray dimensions. Initial lateral and vertical dimensions of the volume source was estimated based on the EPA Guideline, "Volume Source Inputs," EPA's User's Guide for the Industrial Source Complex (ISC-3) Dispersion Model, Volume 1 (EPA 1992b).

^c Emissions would be released over 8,760 hours of operations per year.

Dispersion Analysis Results:

^d 5 years of meteorological data (1991 to 1995) were used in the dispersion modeling analysis. The highest ISC-3 estimated annual concentration (C^{an}) was found to occur during 1991.

ATTACHMENT 13

AIR QUALITY IMPACT ASSESSMENT OF EMISSIONS FROM FIRING SITES

Technical Area(s): TA-14, TA-15, TA-36, TA-39, and TA-40 of the High Explosives Firing Sites (HEFSs)

Emission Sources Detonation of High Explosives at HEFSs Testing Sites

Hydrodynamic experiments involving the detonation of high explosives are conducted at several areas within TA-14, TA-15, TA-36, TA-39, and TA-40. These experiments are used to gain information on the physical properties and dynamic behavior of materials used in nuclear weapons and to evaluate the effects of aging on the nuclear weapons remaining in stockpile. HEFSs combine the capability of testing explosives with the ability to evaluate explosion dynamics.

Screening Analysis

Pollutant(s) Considered

There are up to eight metals that may be emitted into the atmosphere in respirable form during HEFSs testing operations. These include depleted uranium, beryllium, lead, aluminum, copper, tantalum, tungsten, and iron. Two of these TAs (TA-15 and TA-36) have the potential to emit all of these metals; TA-39 may emit all of these metals with the exception of depleted uranium; TA-40 may emit aluminum, copper, tantalum, tungsten, and iron; and TA-14 may emit depleted uranium and lead.

Three of the metals that may be emitted from HEFSs operations, beryllium, lead, and depleted uranium, are highly toxic. The 8-hour Guideline Values (GVs) developed for these pollutants are 0.02 microgram per cubic meter, 0.5 microgram per cubic meter, and 2 micrograms per cubic meter, respectively. The toxicity of depleted uranium is assumed to be the same as for a natural uranium. The other pollutants, copper, tungsten, tantalum, and iron, are moderately toxic, with 8-hour GV's between 10 micrograms per cubic meter and 50 micrograms per cubic meter.

These pollutants were all considered in the air quality impacts analysis. Lithium hydride, another toxic pollutant released from HEFSs operations, was not considered because it is highly reactive and undergoes rapid chemical transformation to lithium hydroxide, which has a very low vapor pressure and no OEL.

Emission Rates of Pollutants Considered

Total amounts of material that are expected to be used for HEFSs activities at each TA, together with the maximum annual and 8-hour respirable release rates were estimated from site operations data. Annual release rates were estimated using the assumption that the release fractions are 10 percent of the total material exploded. The 8-hour release rates of respirable particles were estimated using a scale factor of 0.085. That is, the 8-hour release was estimated by multiplying annual respirable emission rate by a factor of 0.085. This factor was derived from a consideration of the number of tests

per year and the range in amount of material per shot, in order to best represent a release of this duration. The 8-hour emission rate is needed for a comparison with the appropriate SLEV.

Estimated emission rates of pollutants used in the dispersion modeling analysis for each TA are presented in Table A.

Dispersion Modeling Analysis

EPA's Puff Model

Total amount of materials released at each TA during HEFSs operations were modeled using the EPA's Puff Model.

Included in the EPA's TSCREEN Model, the Puff Model is designed to assess the impacts of toxic air pollutants from instantaneous releases. The model is applicable if the travel time to the receptor from the source exceeds the release duration and if the release duration is less than the averaging time of interest to the user.

It is assumed that a HEFSs explosion in the atmosphere reasonably simulates an instantaneous release, where all mass is released in less than 1 to 5 minutes.

The Puff Model conservatively uses worst-case meteorological conditions to determine the maximum concentrations at receptors located directly downwind under the plume centerline. The meteorological conditions that result in a maximum concentration at each of the downwind distances are usually a wind speed of 9.1×10^{-4} feet per second (1 meter per second), a low mixing height (984.24 to 1,640.40 feet [300 to 500 meters]), and stable atmospheric conditions.

The Puff Model assumes that all materials (emissions) are released during a very short period of time (i.e., 1 to 5 minutes), with zero emissions the rest of the averaging time. If the release duration is less than the selected averaging time, the model calculates a concentration reduction based on ratio of the duration time to the averaging time. That is, the estimated maximum instantaneous concentration is converted internally by the model to average 1-minute, 5-minute, 15-minute, and 60-minute concentrations. For this analysis, 60-minute concentrations were estimated and these values were then converted to 8-hour values using a factor 0.125.

Model Inputs Used in the Dispersion Analysis

- The total amount of material released projected from the index for this operation
- The initial dispersion parameters were $Y = 76.11$ feet (23.2 meters) for lateral dispersion and $Z = 30.18$ feet (9.2 meters) for vertical dispersion
- The downwind distances to the receptor locations were as follows:
 - TA-14: 7,496.63 feet (2,285 meters)
 - TA-15: 4,494.70 feet (1,370 meters)
 - TA-36: 1,640.40 feet (500 meters)

- TA-39: 3,001.93 feet (915 meters)
- TA-40: 4,215.83 feet (1,285 meters)
- Ground level release

Estimated emission rates of the pollutants are summarized in Table A.

Results

Estimated 8-hour pollutant concentrations ($C^{8\text{-hr}}$) were compared with the project's 8-hour GVs, 1/100 of the OEL, for each pollutant. Results of the analysis are presented in Table B.

The $GV/C^{8\text{-hr}}$ ratios are less than one (i.e., the estimated concentration of a pollutant is greater than its GV) for the following releases:

- Depleted uranium, beryllium, lead, aluminum, copper, tantalum, tungsten, and iron from TA-15
- Depleted uranium, beryllium, lead, copper, and iron from TA-36
- Beryllium, lead, aluminum, and copper from TA-39
- Depleted uranium and lead from TA-14
- Copper from TA-40

Based on the ratios, depleted uranium, beryllium, and lead are of particular concern. Additional information for a health risk analysis was therefore provided in a further analysis. Due to the fact that all releases from firing operations are short-term, the releases of these pollutants were not considered in the additive impact analysis, which is associated with long-term exposure.

Detailed Analysis

Detailed dispersion modeling was done for HEFSs for the pollutants that exceeded the short-term GVs using the screening analysis. This modeling was conducted using a combination of HOTSPOT 8.0 model and the ISCST3 model. HOTSPOT was used to calculate the effective release height and lateral and vertical dimensions of the volume. These calculated values were used in the ISCST3 modeling, which was run as a volume source model.

Modeling Assumptions

- Amount considered for each test = 154 pounds (70 kilograms)
- Using HOTSPOT, cloud top was calculated
- Cloud top = $76 (w)^{0.25}$, where w is in pounds, and cloud top height is in meters
- Cloud top for 154-pound (70-kilogram) HE detonation = $76 (154 \text{ pounds})^{0.25} = 878.3 \text{ feet}$ (267.7 meters)
- Cloud radius = $0.2 \times \text{cloud top height}$
- Cloud radius = $0.2 \times 267.7 \text{ meters}$
= 175.7 feet (53.54 meters)
- Effective release height = $0.6 (76) (w)^{0.25}$

- Effective release height = $0.6 (76) (w)^{0.25}$
 = 0.6 x 267.7 meters
 = 524.9 feet (160 meters)
- Lateral dimension of the volume in meters, $\sigma_y = 0.5 \times \text{cloud radius}$
- Vertical dimension of the volume in meters, $\sigma_z = 0.2 \times \text{cloud top}$
- Lateral dimension of the volume in meters, $\sigma_y = 0.5 \times 53.54$
 = 87.8 feet (26.77 meters)
- Vertical dimension of the volume in meters, $\sigma_z = 0.2 \times \text{cloud top}$
 = 0.2 x 267.7
 = 175.7 feet (53.54 meters)

Emission Sources Modeled

TA	BERYLLIUM (Be)	DEPLETED URANIUM (DU)	LEAD (Pb)
TA-14	—	X	X
TA-15	X	X	X
TA-36	X	X	X
TA-39	X	—	X

Both the Expanded Operations and the No Action Alternatives were modeled.

Modeled Emission Rates—Expanded Operations Alternative

SOURCE NUMBER	POLLUTANT	ANNUAL RESPIRABLE EMISSION RATE (kg/yr)	HOURLY MODELED EMISSION RATE (g/sec)
TA-14	Depleted Uranium	3.1	0.0001
	Lead	3.1	0.0001
TA-15	Beryllium	3.0	0.0001
	Depleted Uranium	270.0	0.0086
	Lead	15.0	0.0005
TA-36	Beryllium	3.0	0.0001
	Depleted Uranium	120.0	0.0038
	Lead	3.0	0.0001
TA-39	Beryllium	3.0	0.0001
	Lead	3.0	0.0001

The No Action Alternative emission rates are one-third of the Expanded Operations Alternative emission rates. Therefore, modeling for the No Action Alternative was done using one-third of the emission rates stated in the above table.

Location of Sources and Receptors Modeled

SOURCES AND RECEPTORS	STATE PLANE COORDINATES, EAST (ft)	STATE PLANE COORDINATES, NORTH (ft)
TA-14	1,620,310	1,763,740
Receptor for TA-14	1,620,310	1,756,250
TA-15	1,624,875	1,758,375
Receptor for TA-15	1,622,500	1,754,000
TA-36	1,641,250	1,755,875
Receptor for TA-36	1,642,000	1,757,200
TA-39	1,637,875	1,745,500
Receptor for TA-39	1,636,500	1,742,500

Annual Average Modeled Concentrations

SOURCE NUMBER	POLLUTANT	NO ACTION ALTERNATIVE CONCENTRATION (µg/m³)	EXPANDED OPERATIONS ALTERNATIVE CONCENTRATION (µg/m³)
TA-14	Depleted Uranium	0.0	0.0
	Lead	0.0	0.0
TA-15	Beryllium	0.0	0.00001
	Depleted Uranium	0.00015	0.00043
	Lead	0.00001	0.00003
TA-36	Beryllium	0.0	0.00001
	Depleted Uranium	0.00013	0.00039
	Lead	0.0	0.00001
TA-39	Beryllium	0.0	0.00001
	Lead	0.0	0.00001

TABLE A.—Estimated Emission Rates of the Pollutants That Have the Potential to be Released from High Explosives Firing Sites (HEFSs)

NO.	TAS WITH HEFSs TESTING OPERATIONS ^a	POLLUTANTS THAT HAVE THE POTENTIAL TO BE RELEASED DURING TESTING OPERATIONS	ESTIMATED MAXIMUM AMOUNT OF MATERIAL THAT WILL BE USED DURING TESTING OPERATIONS ^b	ESTIMATED RESPIRABLE FRACTION RELEASE RATE		
				ANNUAL RATE ^b	8-HOUR RESPIRABLE RELEASE RATE ^c	
					kg/year	kilograms
1	2	3	4	5	6	7
1	TA-14	Depleted Uranium	31.4	3.1	2.67E+01	2.67E+02
2		Lead	31.4	3.1	2.67E+01	2.67E+02
1	TA-15	Depleted Uranium	2,700	270.0	2.30E+01	2.30E+04
2		Beryllium	30	3.0	2.56E+01	2.56E+02
3		Lead	150	15.0	1.28E+00	1.28E+03
4		Aluminum	450	45.0	3.83E+00	3.83E+03
5		Copper	300	30.0	2.56E+00	2.56E+03
6		Tantalum	300	30.0	2.56E+00	2.56E+03
7		Tungsten	300	30.0	2.56E+00	2.56E+03
8		Iron	150	15.0	1.28E+00	1.28E+03
1	TA-36	Depleted Uranium	1,200	120.0	1.02E+01	1.02E+04
2		Beryllium	30	3.0	2.56E+01	2.56E+02
3		Lead	30	3.0	2.56E+01	2.56E+02
4		Aluminum	30	3.0	2.56E+01	2.56E+02
5		Copper	30	3.0	2.56E+01	2.56E+02
6		Tantalum	30	3.0	2.56E+01	2.56E+02
7		Tungsten	30	3.0	2.56E+01	2.56E+02
8		Iron	150	15.0	1.28E+00	1.28E+03

TABLE A.—Estimated Emission Rates of the Pollutants That Have the Potential to be Released from High Explosives Firing Sites (HEFSs)-Continued

NO.	TAS WITH HEFS TESTING OPERATIONS ^a	POLLUTANTS THAT HAVE THE POTENTIAL TO BE RELEASED DURING TESTING OPERATIONS	ESTIMATED MAXIMUM AMOUNT OF MATERIAL THAT WILL BE USED DURING TESTING OPERATIONS ^b		ESTIMATED RESPIRABLE FRACTION RELEASE RATE		
			kg/year	4	ANNUAL RATE ^b	8-HOUR RESPIRABLE RELEASE RATE ^c	grams ^d
1	2	3	4	5	6	7	
1	TA-39	Beryllium	30	3.0	2.56E-01	2.56E+02	
2		Lead	30	3.0	2.56E-01	2.56E+02	
3		Aluminum ^e	45,000	4,500.0	3.83E+02	3.83E+05	
4		Copper ^e	45,000	4,500.0	3.83E+02	3.83E+05	
5		Tantalum	30	3.0	2.56E-01	2.56E+02	
6		Tungsten	30	3.0	2.56E-01	2.56E+02	
7		Iron ^e	30,000	3,000.0	2.56E+02	2.56E+05	
1	TA-40	Aluminum	240	24.0	2.04E+00	2.04E+03	
2		Copper	300	30.0	2.56E+00	2.56E+03	
3		Tantalum	90	9.0	7.67E-01	7.67E+02	
4		Tungsten	30	3.0	2.56E-01	2.56E+02	
5		Iron	60	6.0	5.11E-01	5.11E+02	

Notes:

Emission Sources:

^a Firing operations involve detonations of explosives at TA-14, TA-15, TA-36, TA-39, and TA-40. Particulate emissions released into the atmosphere due to detonation of high explosives contain bonded metal emissions in respirable form.

Emission Rates of Pollutants Considered:

^b The maximum amount of material that will be used during testing operations and the estimated maximum annual respirable release rates (in kilograms per year per TA) were obtained from Table B for TA-14, Table D for TA-15, Table E for TA-36, Table H for TA-39, and Table J for TA-40 of EPA 1992c. Respirable release rates were estimated based on the assumption that this fraction is 10% of total amount of material exploded.

^c The total 8-hour respirable release rates (in kilograms), as a results of these operations, were estimated using the scale factor of 0.085.

Major Assumptions:

Lithium hydride was not considered because it is highly reactive and undergoes chemical transformations to lithium hydroxide that has very low vapor pressure and no OEL.

Dispersion Analysis:

^d The total amount of material released, in grams, was used in dispersion analysis to estimate maximum 1-hour average concentration at specified receptor locations. Each release was modeled using the EPA's Puff Model as an instantaneous release.

^e These quantities are dominated by the support structures constructed for tests. These structures, in actuality, are not expended in explosive tests and do not contribute to test air emissions.

TABLE B.—Air Quality Impact Analysis of the Pollutants That Have the Potential to be Released from High Explosives Firing Sites (HEFSs)

NO.	TAs WITH HEFSs TESTING OPERATIONS ^a	POLLUTANTS THAT HAVE THE POTENTIAL TO BE RELEASED DURING TESTING OPERATIONS	8-HR RELEASE RATE OF RESPIRABLE FRACTION OF METALS	ESTIMATED CONCENTRATION AT THE SPECIFIED DISTANCES ^{b,c}		GUIDELINE VALUE (GV) (1/100 OF THE OEL)	GV/C ^{8-hr} RATIO
				1-HOUR CONC. ^{c,e,f} (C ^{1-hr})	8-HOUR CONC. ^c (C ^{8-hr})		
1	2	3	grams	µg/m ³	µg/m ³	µg/m ³	8
1	TA-14	Depleted Uranium	2.67E+02	7.17E+01	8.96E+00	2	2.23E-01
2		Lead	2.67E+02	7.17E+01	8.96E+00	0.5	5.58E-02
1	TA-15	Depleted Uranium	2.30E+04	7.61E+03	9.51E+02	2	2.10E-03
2		Beryllium	2.56E+02	8.47E+01	1.06E+01	0.02	1.89E-03
3		Lead	1.28E+03	4.24E+02	5.29E+01	0.5	9.44E-03
4		Aluminum	3.83E+03	1.27E+03	1.58E+02	100	6.31E-01
5		Copper	2.56E+03	8.47E+02	1.06E+02	10	9.44E-02
6		Tantalum	2.56E+03	8.47E+02	1.06E+02	50	4.72E-01
7		Tungsten	2.56E+03	8.47E+02	1.06E+02	50	4.72E-01
8		Iron	1.28E+03	4.24E+02	5.29E+01	50	9.44E-01
1	TA-36	Depleted Uranium	1.02E+04	3.97E+03	4.97E+02	2	4.03E-03
2		Beryllium	2.56E+02	9.97E+01	1.25E+01	0.02	1.60E-03
3		Lead	2.56E+02	9.97E+01	1.25E+01	0.5	4.01E-02
4		Aluminum	2.56E+02	9.97E+01	1.25E+01	100	8.02E+00
5		Copper	2.56E+02	9.97E+01	1.25E+01	10	8.02E-01
6		Tantalum	2.56E+02	9.97E+01	1.25E+01	50	4.01E+00
7		Tungsten	2.56E+02	9.97E+01	1.25E+01	50	4.01E+00
8		Iron	1.28E+03	4.99E+02	6.23E+01	50	8.02E-01

TABLE B.—Air Quality Impact Analysis of the Pollutants That Have the Potential to be Released from High Explosives Firing Sites (HEFSs)-Continued

NO.	TAs WITH HEFSs TESTING OPERATIONS ^a	POLLUTANTS THAT HAVE THE POTENTIAL TO BE RELEASED DURING TESTING OPERATIONS	8-HR RELEASE RATE OF RESPIRABLE FRACTION OF METALS	ESTIMATED CONCENTRATION AT THE SPECIFIED DISTANCES ^{b,c}		GUIDELINE VALUE (GV) (1/100 OF THE OEL)	GV/C ⁸ -hr RATIO
				1-HOUR CONC. ^{c,e,f} (C ¹ -hr)	8-HOUR CONC. ^c (C ⁸ -hr)		
1	2	3	grams	µg/m ³	µg/m ³	µg/m ³	8
1	TA-39	Beryllium	2.56E+02	9.30E+01	1.16E+01	0.02	1.72E-03
2		Lead	2.56E+02	9.30E+01	1.16E+01	0.5	4.30E-02
3		Aluminum	3.83E+05	1.39E+05	1.74E+04	100	5.75E-03
4		Copper	3.83E+05	1.39E+05	1.74E+04	10	5.75E-04
5		Tantalum	2.56E+02	9.30E+01	1.16E+01	50	4.30E+00
6		Tungsten	2.56E+02	9.30E+01	1.16E+01	50	4.30E+00
7		Iron	2.56E+02	9.30E+01	1.16E+01	50	4.30E+00
1	TA-40	Aluminum	2.04E+03	6.87E+02	8.59E+01	100	1.16E+00
2		Copper	2.56E+03	8.63E+02	1.08E+02	10	9.27E-02
3		Tantalum	7.67E+02	2.58E+02	3.23E+01	50	1.55E+00
4		Tungsten	2.56E+02	8.63E+01	1.08E+01	50	4.64E+00
5		Iron	5.11E+02	1.72E+02	2.15E+01	50	2.32E+00

Notes:

Emission Sources:

^a Firing operations involve detonations of explosives at TA-14, TA-15, TA-36, TA-39, and TA-40. Particulate emissions released into the atmosphere due to detonation of high explosives contain bounded metal emissions in respirable form.

Emission Rates of Pollutants Considered:

^b Emission rates of pollutants are from Table A.

Major Assumptions:

^c Estimated 1-hour average concentrations was converted to 8-hour concentrations using a conversion factor of 0.125.

Dispersion Analysis:

^d Total amounts of material released at each TA over 8-hour period were modeled using the EPA's PUFF Model as an instantaneous release scenario with assumed initial dispersion parameters. The lateral dispersion parameter (sigma Y) was assumed to be 23.2 meters; the vertical dispersion parameter (sigma Z) was assumed to be 9.2 meters.

^e The conditions that produced the maximum concentrations at each of the downwind distances were: wind speed of 1 m/sec; mixing height of 320 meters; and stable atmospheric conditions.

^f The downwind distances at which off-site concentrations were estimated were selected on TA by TA basis. These distances are as follows: TA-14, 2,285 meters; TA-15, 1,370 meters; TA-36, 500 meters; TA-39, 915 meters; and TA-40, 1,285 meters.

ATTACHMENT 14

AIR QUALITY IMPACT ASSESSMENT OF THE HEALTH RESEARCH LABORATORY (TA-43) EMISSIONS

Technical Area: TA-43

Emission Source(s)

There are four emission exhaust ducts located on the roof of the Health Research Laboratory (HRL) that emit carcinogenic pollutants from HRL operations. The pollutants of concern for this analysis are chloroform, trichloroethylene, methylene chloride, formaldehyde, and acrylamide.

The releases of pollutants may potentially impact nearby sensitive receptors (such as air intake shafts and/or operable windows) at the LANL Medical Center located in close proximity to HRL. Numerous receptor locations along the face and roof of the hospital were considered. Closest to HRL exhaust duct is an air intake shaft (#1) located within distance of 328 feet (100 meters) of stack B247 on the roof of the HRL.

Source Term Parameters

Annual pollutant emission rates were estimated were those projected for the Expanded Operations Alternative. Associated stack parameters and locations are presented in Table A. It was assumed that annual emissions would be released over 8,760 hours of operation per year.

Dispersion Modeling Analysis

An air quality impacts analysis was conducted using EPA's ISC-3 Model and 5 years of on-site meteorological data. All nearby buildings, including the Medical Center and HRL Building 1, within the zone of the stack plume influence were considered in the downwash analysis.

The highest annual average concentrations of these pollutants were found at the elevated receptors of the Medical Center. These values were then used to estimate the incremental cancer risk of these releases using appropriate unit risk factors.

Results

Results of the analysis are presented in Tables B and C. As shown in Table C, four of the five pollutants considered (chloroform, trichloroethylene, formaldehyde, and acrylamide) have the estimated maximum cancer risk values greater than Guideline Value of 1.0×10^{-8} .

The maximum annual concentration of 3.04×10^{-2} micrograms per cubic meter was estimated for chloroform, the most critical of these carcinogens, at one of the air intake shaft of the Medical Center located at a height of 40 feet (12.2 meters) above the ground level (Refer to the Receptor #175 of the LANL sensitive receptors). The maximum cancer risk of chloroform is estimated to be 6.99×10^{-7} at

this location, and sum of the cancer risks of all of these carcinogens combined is estimated to be 7.79×10^{-7} . These pollutants were further evaluated as a part of the additive impact analysis.

TABLE A.—Stack Parameters and Estimated Annual Emission Rates of the Carcinogenic Pollutants That Have the Potential to be Released from the Health Research Laboratory of the TA-43 Facilities

NO.	POLLUTANTS	STACK ID	STACK PARAMETERS				ANNUAL AVERAGE EMISSION RATES	
			UTM COORD. (X; Y)	HEIGHT	VELOCITY	DIAMETER	lb/year	g/sec
			m	m	m/sec	m		
1	Acrylamide	Bldg. 247	380883; 3971376	12.80	13.41	0.18	5.86E-03	8.44E-08
		Bldg. 124/126	380838; 3971363	14.02	13.41	0.18	5.86E-03	8.44E-08
		N. Side FH	380848; 3971377	16.61	13.41	0.18	5.86E-03	8.44E-08
		S. Side FH	380854; 3971340	12.80	13.41	0.18	5.86E-03	8.44E-08
		Bldg. 247	380883; 3971376	12.80	13.41	0.18	2.20E+00	3.17E-05
2	Chloroform	Bldg. 124/126	380838; 3971363	14.02	13.41	0.18	2.13E+01	3.07E-04
		N. Side FH	380848; 3971377	16.61	13.41	0.18	2.13E+01	3.07E-04
		S. Side FH	380854; 3971340	12.80	13.41	0.18	2.13E+01	3.07E-04
		Bldg. 247	380883; 3971376	12.80	13.41	0.18	1.73E-01	2.50E-06
3	Formaldehyde	Bldg. 124/126	380838; 3971363	14.02	13.41	0.18	1.68E+00	2.41E-05
		N. Side FH	380848; 3971377	16.61	13.41	0.18	1.68E+00	2.41E-05
		S. Side FH	380854; 3971340	12.80	13.41	0.18	1.68E+00	2.41E-05
4	Methylene Chloride	N. Side FH	380848; 3971377	16.61	13.41	0.18	9.46E-01	1.36E-05
		S. Side FH	380854; 3971340	12.80	13.41	0.18	9.46E-01	1.36E-05
5	Trichloroethylene	N. Side FH	380848; 3971377	16.61	13.41	0.18	1.02E+01	1.47E-04

TABLE B.—ISC-3 Estimated Annual Concentrations of the Carcinogenic Pollutants That Have the Potential to be Released from the Health Research Laboratory of the TA-43 Facilities Using 1991 to 1995 Meteorological Data

NO.	POLLUTANTS	ANNUAL ISC-3 ESTIMATED CONCENTRATIONS ($\mu\text{g}/\text{m}^3$)				
		1991	1992	1993	1994	1995
		METEOROLOGICAL DATA				
1	Acrylamide	1.11E-05	1.04E-05	1.15E-05	1.13E-05	1.15E-05
2	Chloroform	2.89E-02	2.60E-02	2.99E-02	2.95E-02	3.04E-02
3	Formaldehyde	2.28E-03	2.04E-03	2.36E-03	2.32E-03	2.40E-03
4	Methylene Chloride	7.20E-04	6.40E-04	7.80E-04	7.60E-04	7.60E-04
5	Trichloroethylene	3.18E-03	2.82E-03	3.22E-03	3.30E-03	3.34E-03

TABLE C.—Results of the Dispersion Modeling Analysis of the Carcinogenic Pollutants from the Health Research Laboratory at TA-43

NO.	CARCINOGENIC POLLUTANTS	CAS NUMBER	CAR CLASS	UNIT RISK FACTORS (URF) ($\mu\text{g}/\text{m}^3$) ⁻¹	ISC-3 ESTIMATED ANNUAL CONCENTRATION ¹ (C_{an})		MAXIMUM CANCER RISK ($C_{\text{an}} \times \text{URF}$)	GUIDELINE VALUE
					$\mu\text{g}/\text{m}^3$			
1	2	3	4	5	6	7	6	
1	Acrylamide	79-06-1	B2	1.30E-03	1.15E-05	1.50E-08	1.50E-08	
2	Chloroform	67-66-3	B2	2.30E-05	3.04E-02	6.99E-07	6.99E-07	
3	Formaldehyde	50-00-0	B1	1.30E-05	2.40E-03	3.12E-08	3.12E-08	
4	Methylene Chloride	75-09-2	B2	4.70E-07	7.80E-04	3.67E-10	3.67E-10	
5	Trichloroethylene	79-01-6	B2	1.00E-05	3.34E-03	3.34E-08	3.34E-08	
Total Combined Maximum Cancer Risk							7.79E-07	1.00E-08

ATTACHMENT 15

AIR QUALITY IMPACT ASSESSMENT OF THE TA-53 CHLOROFORM EMISSIONS

Technical Area: TA-53, Building MPF-15

Emission Source(s)

Chloroform is used for cleaning in preparation for surface chemistry studies using the LANSCE neutron beam. All of the chloroform used evaporates during this process.

There are two emission sources of the chloroform emissions at TA-53; both are located on Building MPF-15. One emission source is an exhaust duct from the clean room and the other is an exhaust duct from chemistry laboratory.

Source Term Parameters

Stack parameters and their locations are provided in Table A.

Emission Rates of Pollutants Considered

Estimated annual emission rates of chloroform from the two emission sources are shown in Table A. All chloroform used is assumed released into the atmosphere. It was assumed that emissions would be released over 8,760 hours of operation per year.

Dispersion Modeling Analysis

An air quality impacts analysis was conducted using EPA's ISC-3 Model and 5 years of on-site meteorological data. All nearby buildings within the zone of stack plume influence were considered in the downwash analysis. The highest annual concentration estimated by the ISC-3 Model (Table B) was used to estimate the maximum cancer risk of chloroform releases using its unit risk factor.

Results

Results of the analysis are presented in Tables B and C. As shown in Table C, the maximum combined cancer risk associated with releases of chloroform from two emission sources on building MPF-15 of the TA-53 facility is 1.29×10^{-8} , which is above the Guideline Value of 1.0×10^{-8} . This pollutant was, therefore, further evaluated as part of the additive impact analysis.

TABLE A.—Stack Parameters and Emission Rate of the Chloroform Associated with TA-53 Building MPF-15

NO.	EMISSIONS SOURCE	STACK ID	STACK PARAMETERS				ESTIMATED ANNUAL EMISSION RATE	
			UTM COORD. (X; Y)	HEIGHT	VELOCITY	DIAMETER	lb/year	g/sec
			m	m	m/sec	m		
1	TA-53 MPF-15 Clean Room	Bldg. 15	386592; 3969778	10.97	15.52	0.15	1.20E+01	1.73E-04
2	TA-53 MPF-15 Chemistry Lab.	Bldg. 15	386589; 3969789	9.30	5.41	0.36	4.00E+00	5.76E-05

TABLE B.—ISC-3-Estimated Annual Concentration of the Chloroform Associated with Emission Source of the TA-53 MPF-15 Using 1991 to 1995 Meteorological Data

EMISSION SOURCE	ISC-3 ESTIMATED ANNUAL AVERAGE CONCENTRATIONS ($\mu\text{g}/\text{m}^3$)			
	1991	1992	1993	1994
TA-53 MPF-15 Chemistry Lab. & Clean Room	4.30E-04	5.60E-04	5.20E-04	5.20E-04
				5.30E-04

TABLE C.—Results of the Dispersion Modeling Analysis of the Chloroform Emissions from TA-53 Building MPF-15

NO.	EMISSION SOURCE	CHLOROFORM UNIT RISK FACTOR (URF)	ISC-3 ESTIMATED ANNUAL CONCENTRATION (C_{an})	MAXIMUM CANCER RISK ($C_{an} \times \text{URF}$)	GUIDELINE VALUE
		$(\mu\text{g}/\text{m}^3)^{-1}$	$\mu\text{g}/\text{m}^3$		
1	2	3	4	5	6
1	TA-53 MPF-15 Chemistry Lab. & Clean Room	2.30E-05	5.60E-04	1.29E-08	1.00E-08

ATTACHMENT 16

AIR QUALITY IMPACT ASSESSMENT OF THE TA-55 BERYLLIUM EMISSIONS

Technical Area: TA-55, Building PF-4

Emission Source(s)

There are two beryllium emission sources at TA-55, located on Building PF-4, TA-55 FE-15 and TA-55 FE-16.

Source Term Parameters

Stack parameters and their locations are shown in Table A.

Emission Rates of Pollutants Considered

Annual emission rates of the beryllium were estimated based on the existing permit application for TA-55. Emissions from these sources are released to the atmosphere through a HEPA filtration system, with a removal efficiency of 99.95 percent. Controlled emission rates are estimated to be 3.0×10^{-3} pounds per year for TA-55 FE-15 and 4.2×10^{-3} pounds per year for TA-55 FE-16.

Estimated annual emission rates of the beryllium that were used in the analysis are shown in Table A. It was assumed that emissions would be released over 8,760 hours of operation per year.

Dispersion Modeling Analysis

An air quality impacts analysis was conducted using EPA's ISC-3 Model and 5 years of on-site meteorological data. All nearby buildings within the zone of stack plume influence were considered in the downwash analysis. The highest annual concentration estimated by the ISC-3 Model (Table B) was used to compute the maximum combined cancer risk of beryllium releases using its unit risk factor.

Results

Results of the analysis are presented in Tables B and C. As shown in Table C, the combined cancer risk associated with releases of beryllium from emission sources on Building PF-4, TA-55 FE-15 and TA-55 FE-16, is 2.35×10^{-10} , which is below the Guideline Value of 1.0×10^{-8} .

TABLE A.—Stack Parameters and Annual Beryllium Emission Rates Associated with TA-55 Building PF-4 Emission Sources FE-15 and FE-16

NO.	EMISSION SOURCES	STACK ID	STACK PARAMETERS				PERMITTED ANNUAL EMISSION RATE	
			UTM COORD. (X; Y)	HEIGHT	VELOCITY	DIAMETER	lb/year	g/sec
			m	m	m/sec	m		
1	TA-55 FE-15	FE-15	382458; 3969439	15.24	19.20	0.91	3.00E-03	4.32E-08
2	TA-55 FE-16	FE-16	382416; 3969359	9.45	12.80	0.91	4.20E-03	6.05E-08

TABLE B.—TA-55 ISC-3 Estimated Annual Concentrations of the Beryllium Using 1991 to 1995 Meteorological Data

EMISSION SOURCE	ISC-3 ESTIMATED ANNUAL AVERAGE CONCENTRATION ($\mu\text{g}/\text{m}^3$)			
	1991	1992	1993	1994
TA-55 Building PF-4 FE-15 & FE-16	9.00E-08	6.40E-08	9.90E-08	8.70E-08

TABLE C.—Results of the Dispersion Modeling Analysis of the Beryllium Emissions from TA-55 Sources FE-15 and FE-16

NO.	EMISSION SOURCE	BERYLLIUM UNIT RISK FACTOR (URF)	ISC-3 ESTIMATED ANNUAL CONC (C_{an})	COMBINED MAXIMUM CANCER RISK ($C_{\text{an}} \times \text{URF}$)	GUIDELINE VALUE
		$(\mu\text{g}/\text{m}^3)^{-1}$	$\mu\text{g}/\text{m}^3$		
1	2	3	4	5	6
1	TA-55 Building PF-4 FE-15 & FE-16	2.40E-03	9.90E-08	2.38E-10	1.00E-08

ATTACHMENT 17

AIR QUALITY IMPACT ASSESSMENT OF THE TA-55 HYDROCHLORIC AND NITRIC ACID EMISSIONS

Technical Area: TA-55, Building PF-4, Stacks FE-15 and FE-16

Emission Source(s)

The chemistry group at TA-59 uses nitric and hydrochloric acids for the recovery of plutonium. There are few emission sources of hydrochloric and nitric acid at TA-55. The two sources that were considered in the analysis include stacks FE-15 and FE-16, located on Building PF-4.

Source Term Parameters

Stack parameters and their locations are provided in Table A.

Emission Rates of Pollutants Considered

Estimated maximum hourly emission rates of nitric acid and hydrochloric acids associated with stacks FE-15 and FE-16 that were used in the analysis are shown in Table A. It was assumed that emissions would be released over 8,760 hours of operation per year.

Dispersion Modeling Analysis

An air quality impacts analysis was conducted using EPA's ISC-3 Model and 5 years of on-site meteorological data. All nearby buildings within the zone of stack plume influence were considered in the downwash analysis.

The ISC-3-estimated 8-hour concentrations of nitric and hydrochloric acids are shown in Table B. Using these values and appropriate 8-hour Guideline Values (GVs), 8-hour SLEVs were estimated and compared to hourly emission rates of these pollutants.

Results

Results of the analysis are presented in Table C. As shown in Table C, the 8-hour concentrations of both hydrochloric acid and nitric acid are below the 8-hour GV. Accordingly, 8-hour SLEV/Q ratios are all greater than one. That is, the estimated nitric acid and hydrochloric acid levels are below the applicable GV.

TABLE A.—Stack Parameters and Emission Rate of Hydrochloric and Nitric Acid Associated with TA-55 Building PF-4

NO.	EMISSION SOURCE/ POLLUTANT	STACK ID	STACK PARAMETERS				MAXIMUM HOURLY EMISSION RATE	
			UTM COORD. (X; Y) m	HEIGHT m	VELOCITY m/sec	DIAMETER m	lb/hour	g/sec
1	TA-55 Building PF-4 Hydrochloric Acid	FE-15	382458; 3969439	15.24	19.20	0.91	0.533	0.0672
2	Nitric Acid						0.360	0.0454
1	TA-55 Building PF-4 Nitric Acid	FE-16	382416; 3969359	9.45	12.80	0.91	2.42	0.305

TABLE B.—ISC-3 Estimated 8-Hour Concentration of the Hydrochloric and Nitric Acid Associated with TA-55 Building PF-4 Using 1991 to 1995 Meteorological Data

NO.	EMISSION SOURCE/POLLUTANT	ISC-3 ESTIMATED 8-HOUR CONCENTRATION ($\mu\text{g}/\text{m}^3$)				
		METEOROLOGICAL DATA				
		1991	1992	1993	1994	1995
1	TA-55 Building PF-4, Stack FE-15, Hydrochloric Acid	2.36	2.81	1.87	3.10	1.94
2	TA-55 Building PF-4, Stack FE-15/FE-16, Nitric Acid	39.8	35.9	41.5	41.8	33.0

TABLE C.—Results of the Dispersion Modeling Analysis of the Hydrochloric and Nitric Acid Emission from TA-55 Building PF-4 Stack FE-15 and FE-16

NO.	SOURCE	POLLUTANT	ISC-3 ESTIMATED 8-HOUR CONCENTRATION $\mu\text{g}/\text{m}^3$	GUIDELINE VALUE (1/100 OF THE OELS) $\mu\text{g}/\text{m}^3$	8-HOUR SLEVS lb/hr	HOURLY EMISSION RATE (Q^h) lb/hr	SLEVS/ Q^h RATIO
1	2	3	3.10	70.0	12.0	0.533	22.5
1	TA-55 Building PF-4, Stack FE-15	Hydrochloric Acid	41.8	52.0	3.46	2.78	1.25
2	TA-55 Building PF-4, Stack FE-15/FE-16	Nitric Acid					

ATTACHMENT 18

AIR QUALITY IMPACT ASSESSMENT OF THE TA-59 HYDROCHLORIC AND NITRIC ACIDS EMISSIONS

Technical Area: TA-59, Building 1

Emission Source(s)

The radio chemistry group at TA-59 uses large quantities of nitric and hydrochloric acid for the digestion and separation processes. One percent of each chemical is estimated to be released to the atmosphere due to container transfer.

There are two groups of emission sources of the hydrochloric and nitric acid at TA-59. They are both located on Building 1 and include exhaust fume hoods from laboratory rooms. One group of emission sources is associated with Hoods #102 through 106, and the other with Hoods #184 through 186. One representative stack with equivalent source parameters was used in the dispersion analysis for each group of these emissions sources.

Source Term Parameters

Stack parameters and their locations are provided in Table A.

Emission Rates of Pollutants Considered

Estimated maximum hourly emission rates of nitric acid and hydrochloric acids associated with two groups of emission sources that were used in the analysis are shown in Table A.

Dispersion Modeling Analysis

An air quality impacts analysis was conducted using EPA's ISC-3 Model and 5 years of on-site meteorological data. All nearby buildings within the zone of stack plume influence were considered in the downwash analysis.

Due to the fact that laboratory operating schedules are related to the daytime, the 8-hour concentration was computed for this time period. The highest daytime 8-hour concentration of hydrochloric and nitric acid was found to occur between 8:00 a.m. and 4:00 p.m. in 1991, at the receptor site located near boundary of TA-59 on Pajarito Road (Table B). These concentrations were compared to the appropriate 8-hour Guideline Values (GVs).

Results

Results of the analysis are presented in Table C. As shown in Table C, the 8-hour concentration of the nitric acid is above the 8-hour GV, and the 8-hour concentration of the hydrochloric acid is below the 8-hour GV. The results of the nitric acid analysis, therefore, were referred to the human health and ecological risk assessment process.

TABLE A.—Stack Parameters and Emission Rate of the Hydrochloric and Nitric Acid Associated with Emission Sources of the TA-59 Building 1

NO.	EMISSION SOURCE/ POLLUTANT ^a	STACK PARAMETERS						ESTIMATED MAXIMUM HOURLY EMISSION RATE	
		UTM COORD. (X; Y)	HEIGHT	AIRFLOW ^{b,c}	VELOCITY	DIAMETER			
		m	m	m ³ /sec	m/sec	m	lb/hr	g/sec	
1	TA-59 Rooms 102-106, Nitric Acid	381228; 3969886	18.29	8.73	14.06	0.89	5.00E+00	6.30E-01	
2	TA-59 Rooms 184-186, Nitric Acid	381218; 3969911	12.27	0.54	5.80	0.34	2.50E+00	3.15E-01	
3	TA-59 Rooms 102-106, Hydrogen Chloride	381228; 3969886	18.29	8.73	14.06	0.89	1.48E+00	1.86E-01	
4	TA-59 Rooms 184-186, Hydrogen Chloride	381218; 3969911	12.27	0.54	5.80	0.34	7.20E-01	9.07E-02	

Notes:

^a All emission sources associated with a fume hoods on Building 1 were divided into the two categories: emission sources from Room 102-106 and emission sources from Room 184-186. A representative stack from each group of emissions sources was used in the dispersion modeling analysis.

^b Due to the fact that fume hoods in Rooms 102, 103, 104, and 106 are connected to the central exhaust system, the total airflow rate of 18,500 cubic feet per minute going through the central system was used to estimate the average flow rate associated with a first group of emission sources.

^c The average airflow rate associated with fume hoods of the second group of emission sources was estimated using the actual flow rate of each hood.

TABLE B.—ISC-3 Estimated 8-Hour Concentration of the Hydrochloric and Nitric Acid Associated with Emission Source of the TA-59 Building 1 Using 1991 to 1995 Meteorological Data^a

EMISSION SOURCE/POLLUTANT	8-HOUR ESTIMATED CONCENTRATIONS (µg/m ³)				
	1991	1992	1993	1994	1995
TA-59 Building 1, Nitric Acid	83.8	87.4	120.0	91.8	83.2
TA-59 Building 1, Hydrogen Chloride	24.2	25.2	34.7	26.5	24.0

^a The highest ISC-3 estimated 8-hour concentration of nitric and hydrochloric acid during daytime (between 8 a.m. and 4 p.m.) was found to occur in 1993.

TABLE C.—Results of the Dispersion Modeling Analysis of the Hydrochloric and Nitric Acid Emissions from TA-59 Building 1

NO.	POLLUTANT	ISC-3 ESTIMATED 8-HOUR CONCENTRATION	8-HOUR GUIDELINE VALUE (1/100 OF THE OELs)	GV/8-HOUR CONCENTRATION RATIO
		µg/m ³	µg/m ³	
1	2	3	4	5
1	Nitric Acid	120.0	52.0	0.433
2	Hydrogen Chloride	34.7	70.0	2.02

ATTACHMENT 19

AIR QUALITY IMPACT ASSESSMENT OF THE TA-53 OZONE EMISSIONS

Technical Area: TA-53, Building MPF-14

Emission Source(s)

Ozone is generated as a by-product from operation of the advanced free electron laser at TA-53. The source of ozone emissions is located at TA-53 Building MPF-14.

Source Term Parameters

Stack parameters, locations of emission sources, and the estimated maximum hourly emission rates of ozone are shown in Table A.

Dispersion Modeling Analysis

An air quality impacts analysis was conducted using EPA's ISC-3 Model and 5 years of on-site meteorological data. All nearby buildings within the zone of stack plume influence were considered in the downwash analysis.

The ISC-3-estimated 1-hour and 8-hour ozone concentrations are provided in Tables B and C, respectively. These values were compared with corresponding 1-hour National Ambient Air Quality Standards (NAAQS) ozone standard, and appropriate 8-hour Guideline Values (GVs).

Results

Results of the analysis are presented in Table D. As shown in Table D, the 1-hour and 8-hour ozone concentrations are below the applicable standards and GV's.

TABLE A.—Stack Parameters and Emission Rate Associated with Ozone Emissions from TA-53 Building MPF-14

NO.	EMISSION SOURCE	STACK ID	STACK PARAMETERS				MAXIMUM HOURLY EMISSION RATE	
			UTM COORD. (X; Y)	HEIGHT	VELOCITY	DIAMETER	g/hr	g/sec
1	TA-53 MPF-14	B14	386180; 3969696	1.8	5.0	0.35	8.58E-01	2.38E-04

TABLE B.—ISC-3 Estimated 1-Hour Concentration of the Ozone Associated with Emission Source of the TA-53 MPF-14 Using 1991 to 1995 Meteorological Data

EMISSION SOURCE	ISC-3 ESTIMATED 1-HOUR CONCENTRATION ($\mu\text{g}/\text{m}^3$) ^a			
	METEOROLOGICAL DATA			
TA-53 Building MPF-14	1991	1992	1993	1994
	0.858	0.332	0.608	0.503
				1995
				0.343

Note:
^a 5 years of meteorological conditions were used in the dispersion analysis. The ISC-3 estimated 1-hour ozone concentration was found to occur in 1991.

TABLE C.—ISC-3 Estimated 8-Hour Ozone Concentration Associated with Emission Source of the TA-53 MPF-14 Using 1991 to 1995 Meteorological Data

EMISSION SOURCE	ISC-3 ESTIMATED 8-HOUR CONCENTRATION ($\mu\text{g}/\text{m}^3$)			
	METEOROLOGICAL DATA			
	1991	1992	1993	1994
TA-53 Building MPF-14	1.07E-01	5.85E-02	7.59E-02	6.41E-02
				4.84E-02

TABLE D.—Results of the Dispersion Modeling Analysis of the Ozone Emissions from TA-53 Building MPF-14

EMISSION SOURCE	ISC-3 ESTIMATED CONCENTRATION		NAAQS ^a 1-HOUR CONCENTRATION $\mu\text{g}/\text{m}^3$	8-HOUR GUIDELINE VALUE (1/100 OF THE OELS) $\mu\text{g}/\text{m}^3$
	1-HOUR CONCENTRATION $\mu\text{g}/\text{m}^3$	8-HOUR CONCENTRATION $\mu\text{g}/\text{m}^3$		
	1	2	3	4
TA-53, Building MPF-14	0.858	0.107	235	2

^a NAAQS = National Ambient Air Quality Standards

(This Page Intentionally Left Blank)

REFERENCES

- ACGIH 1997 *Guide to Occupational Exposure Values*. American Conference of Governmental Industrial Hygienists. 1997
- Auer 1978 “Correlation of Land Use and Cover with Meteorological Anomalies.” A. H. Auer. *Journal of Applied Meteorology*. Vol. 17. 1978
- BBER 1995 *Projected Population Data for New Mexico Counties*. Bureau of Business and Economic Research. Santa Fe, New Mexico. 1995.
- Bowen 1990 *Los Alamos Climatology*. Brent Bowen. LA-11735-MS. UC-902. University of California, Berkeley, and Los Alamos National Laboratory. Los Alamos, New Mexico. 1990.
- Carter 1978 *Emissions from Open Burning or Detonation of Explosives*. Roy V. Carter. Paper presented at the 71st meeting of the Air Pollution Control Association. Houston, Texas. June 25–30, 1978.
- DOC 1991 *1990 Census of Population and Housing: Summary Population and Housing Characteristics, New Mexico*. U.S. Department of Commerce, Bureau of the Census. 1990 CPH-1-33. Washington, D.C. August 1991.
- EPA 1988 *A Workbook of Screening Techniques for Assessing Impacts of Toxic Air Pollutants*. U.S. Environmental Protection Agency, Office of Air Quality Planning and Standards, Technical Support Division. EPA-450/4-88-009. Research Triangle Park, North Carolina. 1988.
- EPA 1992a *User Guide for CAP-88-PC*. U.S. Environmental Protection Agency. Washington, D.C. March 1992.
- EPA 1992b *Industrial Source Complex (ISC) Dispersion Model User Guide, Volume 1*. U.S. Environmental Protection Agency, Office of Air Quality Planning and Standards, Technical Support Division. EPA-450/4-92-008a. Research Triangle Park, North Carolina. 1992.
- EPA 1992c *Guideline on Air Quality Models (Revised)*. U.S. Environmental Protection Agency, Office of Air and Radiation, Office of Air Quality Planning and Standards. EPA-450/2-78-027R. Research Triangle Park, North Carolina. 1992.
- EPA 1992d *Tutorial Package For the TSCREEN Model, Puff Model*. U.S. Environmental Protection Agency, Office of Air Quality Planning and Standards, Technical Support Division. EPA-450/4-90-013. Research Triangle Park, North Carolina. 1992.

- EPA 1992e *Screening Procedures for Estimating the Air Quality Impact of Stationary Sources*, Revised. U.S. Environmental Protection Agency, Office of Air and Radiation, Office of Air Quality Planning and Standards. EPA-454/R-92-019. Research Triangle Park, North Carolina. 1992.
- EPA 1992f *A Tiered Modeling Approach For Assessing The Risks Due To Sources Of Hazardous Air Pollutants*. U.S. Environmental Protection Agency, Office of Air Quality Planning and Standards, Technical Support Division. EPA-450/4-92-001. Research Triangle Park, North Carolina. 1992.
- EPA 1993a *User's Guide to the Building Profile Input Program (BPIP)*. U.S. Environmental Protection Agency, Office of Air Quality Planning and Standards, Technical Support Division. Research Triangle Park, North Carolina. 1993.
- EPA 1993b *Integrated Risk Information System (IRIS) Data Base, Version 1.0*. U.S. Environmental Protection Agency, Office of Research and Development. 1993.
- EPA 1995 "Compilation of Air Pollutant Emission Factors," Vol. 1. *Stationary Point and Area Sources*. U.S. Environmental Protection Agency. AP-42. January 1995
- LANL 1990 *Nonradioactive Air Emissions Inventory (Regulated Air Pollutants Reports)*. Los Alamos National Laboratory, Air Quality and Meteorology Section, Environmental Protection (EM-8), Environmental Management. Los Alamos, New Mexico. 1990.
- LANL 1995a *Automatic Chemical Inventory System*. Los Alamos National Laboratory. Los Alamos, New Mexico. January 1996.
- LANL 1995b *20 NMAC 2.70 Operating Permit Application for Los Alamos National Laboratory (Title V Permit Application)*. Los Alamos National Laboratory. LA-UR-95-4192. Los Alamos, New Mexico. December 1995.
- ORNL-LLNL 1996 *HOTSPOT 8.0*, CCC-644. Radiation Shielding Information Center. Oak Ridge National Laboratory and Lawrence Livermore Laboratory. January 1996.
- TCI 1996 *Breeze AirTM ISC-3, Version 2.0, User's Guide for Windows*. Trinity Consultants Incorporated. 1996.
- Tewerson 1985 *Prediction of Fire Properties of Materials, Part 1*. A. Tewerson. Factory Mutual Research Corporation. December 1985.

APPENDIX C

CONTAMINANT DATA SETS SUPPORTING ECOLOGICAL AND HUMAN HEALTH CONSEQUENCE ANALYSIS

Appendix C consists of nine statistical data tables constructed from databases maintained as part of LANL's Environmental Surveillance Program and Environmental Restoration (ER) Project. The tables include columns for: (1) the number of times for which the analyte was detected; (2) the number of times the analyte was sampled; (3) units; (4) the minimum, maximum, and arithmetic mean values; and (5) the 95 percent confidence limit (mean, plus two standard deviations). Only analytes that were detected at least once during the sampling period (1990 to 1996) are shown. Mean values and values for the 95 percent confidence interval are reported in exponential notation and rounded to two significant figures.

The NPDES table, Table C-1, consists of 1994 to 1996 data tabulated by the Water Quality and Hydrology Group (ESH-18) from laboratory inorganic trace analysis (CST-9) reports. The data are arranged by watershed.

Surface water and sediment tables, Tables C-2 through C-5, consist of environmental surveillance and compliance program data from the years 1991 through 1996, found in the LANL Environmental Surveillance Reports (e.g., *Environmental Surveillance at Los Alamos During 1995*, LANL 1996b). The data are arranged by location (on site, perimeter, and regional) and by watershed.

Groundwater tables, Tables C-6 and C-7, also consist of LANL environmental surveillance compliance program data from 1991 through 1996, found in the LANL Environmental Surveillance and Reports. The data are arranged by groundwater regime (alluvial, intermediate,

and main) and by watershed (for alluvial and intermediate only).

Soils tables, Tables C-8 and C-9, consist of ER Project data. The data are arranged by both analyte and by watershed. Tables C-8 and C-9 in the Draft SWEIS contained incorrect data and these two tables have been completely reconstructed to eliminate these errors. These errors were a result of including data collected in the early phases of the ER Project that had not undergone quality assurance screening. These data contained known laboratory analytical errors, contained errors in unit conversions, and contained errors from samples contaminated either during sample collection or in the chemical laboratory during analysis. The problem occurred during data extraction because these samples with known problems were not screened. The corrected tables only use those data from the ER Project that have undergone quality assurance screening and are known to be error free.

Tables were constructed by first summing the total number of analyses for each analyte and reporting the number in the "Analyzed" column of each table. For radioactivity measurements, all zero and negative results were removed from the data set, and the remaining results were summed for each analyte and reported in the "Detected" column. Thus, for radionuclides, many results below the detection limit determined by the analytical laboratory are represented in the table as "Detects." For constituents other than radioactivity measurements, all non-detect results were removed from the data set, and the remaining results were summed for each analyte and reported in the "Detected" column. These

detected results were used to calculate the minimum, mean, maximum, and 95 percent confidence limit. The detected results were not compared to either the detection limit for the analytical laboratory or the associated counting uncertainty for radionuclides. Thus, for radiochemical analyses of groundwater, surface water, and sediment, the detected results do not agree with LANL's Environmental Surveillance Program's definition of "detects" as results that are (1) greater than the detection limit and (2) equal to or greater than 4.66 times the counting uncertainty.

Because only positive "detects" were averaged, not the total number of samples analyzed, the number of "detects" is thus higher than reported

in the LANL Environmental Surveillance Reports, and the mean and 95 percent upper confidence limits appearing in the Appendix C tables are artificially high. When used elsewhere in the SWEIS, such as in the analyses of human health impacts, these values thus (intentionally) result in conservative estimates of the consequences of LANL operations.

Data from Tables C-1 through C-7 were used in the study of the ingestion pathway in the human health analysis (section D.3.3 of appendix D). Data from Tables C-8 and C-9 are not used in the SWEIS but provided for additional information.

TABLE C-1.—NPDES Detection Statistics by Watershed (NPDES Data 1994 to 1996)

WATERSHED	ANALYTE ^a	UNITS ^b	DETECTED	ANALYZED	MINIMUM	MEAN	MAXIMUM	95% UCL ^c
Ancho	Boron (T)	mg/l	3	3	0.02	2.3E-02	0.03	3.5E-02
	Cadmium (T)	mg/l	2	3	0.0001	2.0E-04	0.0003	4.8E-04
	Chromium (T)	mg/l	2	3	0.005	5.5E-03	0.006	6.9E-03
	Copper (T)	mg/l	2	3	0.012	2.1E-02	0.029	4.5E-02
	Lead (T)	mg/l	2	3	0.003	3.0E-03	0.003	3.0E-03
	Radium-226, Radium-228	pCi/l	3	3	0.386	6.5E+00	18.503	2.7E+01
	Tritium	pCi/l	1	3	400	4.0E+02	400	
	Vanadium (T)	mg/l	3	3	0.009	1.0E-02	0.012	1.3E-02
	Zinc (T)	mg/l	2	3	0.04	6.0E-02	0.08	1.2E-01
	Aluminum (T)	mg/l	2	2	0.097	9.9E-02	0.1	1.0E-01
	Arsenic (T)	mg/l	1	1	0.0034	3.4E-03	0.0034	
Cañada del Buey	Boron (T)	mg/l	2	2	0.06	6.1E-02	0.061	6.2E-02
	Cadmium (T)	mg/l	1	2	0.0001	1.0E-04	0.0001	
	Chromium (T)	mg/l	2	2	0.015	2.1E-02	0.027	3.8E-02
	Radium-226, Radium-228	pCi/l	2	2	0.269	1.5E+00	2.695	4.9E+00
	Selenium (T)	mg/l	1	2	0.0022	2.2E-03	0.0022	
	Tritium	pCi/l	1	2	1000	1.0E+03	1000	
	Vanadium (T)	mg/l	2	2	0.009	1.5E-02	0.021	3.2E-02
	Zinc (T)	mg/l	1	2	0.026	2.6E-02	0.026	

TABLE C-1.—NPDES Detection Statistics by Watershed (NPDES Data 1994 to 1996)-Continued

WATERSHED	ANALYTE ^a	UNITS ^b	DETECTED	ANALYZED	MINIMUM	MEAN	MAXIMUM	95% UCL ^c	
Guaje	Aluminum (T)	mg/l	4	6	0.1	2.4E-01	0.4	5.1E-01	
	Arsenic (T)	mg/l	4	6	0.003	1.1E-02	0.027	3.3E-02	
	Boron (T)	mg/l	6	6	0.02	4.8E-02	0.065	8.1E-02	
	Cadmium (T)	mg/l	1	6	0.002	2.0E-03	0.002		
	Chromium (T)	mg/l	1	6	0.016	1.6E-02	0.016		
	Cobalt (T)	mg/l	2	6	0.005	6.5E-03	0.008	1.1E-02	
	Copper (T)	mg/l	3	6	0.032	1.0E-01	0.23	3.2E-01	
	Lead (T)	mg/l	1	6	0.045	4.5E-02	0.045		
	Radium-226, Radium-228	pCi/l	6	6	0.386	2.0E+00	5.469	6.3E+00	
	Tritium	pCi/l	3	6	6	3.0E+02	700	1.0E+03	
	Vanadium (T)	mg/l	6	6	0.014	2.7E-02	0.058	6.1E-02	
	Zinc (T)	mg/l	6	6	0.02	1.6E-01	0.52	5.7E-01	
	Los Alamos	Aluminum (T)	mg/l	5	21	0.1	1.0E-01	0.1	1.0E-01
		Arsenic (T)	mg/l	11	13	0.002	1.3E-02	0.072	5.3E-02
Boron (T)		mg/l	21	21	0.01	6.7E-02	0.15	1.4E-01	
Cadmium (T)		mg/l	2	21	0.0001	1.0E-04	0.0001	1.0E-04	
Chromium (T)		mg/l	17	20	0.004	9.5E-03	0.022	2.0E-02	
Cobalt (T)		mg/l	2	21	0.003	4.0E-03	0.005	6.8E-03	
Copper (T)		mg/l	15	20	0.004	5.8E-02	0.59	3.5E-01	
Lead (T)		mg/l	3	21	0.003	1.5E-02	0.04	5.8E-02	
Radium-226, Radium-228		pCi/l	21	21	0.02	1.1E+00	7.968	4.6E+00	
Selenium (T)		mg/l	7	21	0.001	1.9E-03	0.002	2.6E-03	
Tritium		pCi/l	11	21	100	3.2E+02	700	7.1E+02	
Vanadium (T)		mg/l	21	21	0.01	2.6E-02	0.06	5.0E-02	
Zinc (T)		mg/l	19	21	0.02	8.6E-02	0.3	2.2E-01	

TABLE C-1.—NPDES Detection Statistics by Watershed (NPDES Data 1994 to 1996)-Continued

WATERSHED	ANALYTE ^a	UNITS ^b	DETECTED	ANALYZED	MINIMUM	MEAN	MAXIMUM	95% UCL ^c
Mortandad	Aluminum (T)	mg/l	8	19	0.06	1.6E-01	0.3	3.4E-01
	Arsenic (T)	mg/l	10	14	0.002	3.5E-03	0.0052	5.9E-03
	Boron (T)	mg/l	19	19	0.02	6.9E-02	0.23	1.8E-01
	Cadmium (T)	mg/l	5	18	0.0002	4.9E-03	0.023	2.5E-02
	Chromium (T)	mg/l	15	18	0.005	1.4E-02	0.063	4.5E-02
	Cobalt (T)	mg/l	2	19	0.006	1.7E-02	0.028	4.8E-02
	Copper (T)	mg/l	12	18	0.004	7.6E-02	0.54	3.8E-01
	Lead (T)	mg/l	3	18	0.002	6.3E-03	0.011	1.5E-02
	Mercury (T)	mg/l	1	18	0.0006	6.0E-04	0.0006	
	Radium-226, Radium-228	pCi/l	18	18	0.02	3.2E+00	11.9	1.1E+01
	Selenium (T)	mg/l	2	19	0.0028	4.6E-03	0.0063	9.5E-03
	Tritium	pCi/l	14	19	82	1.2E+04	134143	8.4E+04
	Vanadium (T)	mg/l	16	19	0.003	1.6E-02	0.037	3.6E-02
	Zinc (T)	mg/l	15	18	0.02	1.5E-01	1.2	7.5E-01
Pajarito	Aluminum (T)	mg/l	8	22	0.1	3.5E-01	1	1.0E+00
	Arsenic (T)	mg/l	10	22	0.0016	3.0E-03	0.009	7.6E-03
	Boron (T)	mg/l	23	23	0.02	1.5E-01	2.5	1.2E+00
	Cadmium (T)	mg/l	9	23	0.0001	1.0E-03	0.003	3.3E-03
	Chromium (T)	mg/l	16	23	0.004	1.2E-02	0.07	4.4E-02
	Cobalt (T)	mg/l	6	23	0.0005	3.8E-03	0.005	7.3E-03
	Copper (T)	mg/l	13	23	0.004	2.5E-02	0.15	1.0E-01
	Lead (T)	mg/l	6	23	0.002	6.5E-03	0.014	1.5E-02
	Mercury (T)	mg/l	3	23	0.00035	3.8E-04	0.0004	4.4E-04

TABLE C-1.—NPDES Detection Statistics by Watershed (NPDES Data 1994 to 1996)-Continued

WATERSHED	ANALYTE ^a	UNITS ^b	DETECTED	ANALYZED	MINIMUM	MEAN	MAXIMUM	95% UCL ^c
Pajarito (cont.)	Radium-226, Radium-228	pCi/l	23	23	0.026	1.7E+00	8.198	7.2E+00
	Selenium (T)	mg/l	3	23	0.001	1.3E-03	0.002	2.5E-03
	Tritium	pCi/l	11	23	162	6.0E+02	2900	2.2E+03
	Vanadium (T)	mg/l	23	23	0.005	1.2E-02	0.037	2.7E-02
	Zinc (T)	mg/l	21	23	0.02	6.2E-02	0.19	1.6E-01
	Aluminum (T)	mg/l	6	17	0.1	3.0E-01	0.8	8.4E-01
	Arsenic (T)	mg/l	10	14	0.003	6.2E-03	0.026	2.0E-02
	Boron (T)	mg/l	17	17	0.03	6.9E-02	0.18	1.4E-01
	Cadmium (T)	mg/l	3	17	0.0001	1.7E-04	0.0003	4.0E-04
	Chromium (T)	mg/l	12	17	0.004	1.9E-02	0.06	5.5E-02
Sandia	Cobalt (T)	mg/l	6	17	0.003	6.5E-03	0.01	1.2E-02
	Copper (T)	mg/l	11	17	0.004	1.3E-02	0.034	3.3E-02
	Lead (T)	mg/l	3	17	0.004	1.0E-02	0.023	3.2E-02
	Mercury (T)	mg/l	1	17	0.0017	1.7E-03	0.0017	
	Radium-226, Radium-228	pCi/l	17	17	0.202	1.4E+00	6.457	4.5E+00
	Selenium (T)	mg/l	3	17	0.00145	2.3E-03	0.0034	4.3E-03
	Tritium	pCi/l	9	17	100	2.8E+02	700	6.9E+02
	Vanadium (T)	mg/l	16	16	0.007	1.7E-02	0.036	3.6E-02
	Zinc (T)	mg/l	17	17	0.016	5.9E-02	0.16	1.5E-01
	Aluminum (T)	mg/l	7	27	0.1	2.9E-01	1.2	1.1E+00
Water	Arsenic (T)	mg/l	14	26	0.002	4.0E-03	0.018	1.2E-02
	Boron (T)	mg/l	27	27	0.018	6.8E-02	0.45	2.4E-01
	Cadmium (T)	mg/l	4	27	0.0002	1.1E-03	0.002	3.2E-03
	Chromium (T)	mg/l	14	26	0.004	6.6E-03	0.017	1.4E-02
	Cobalt (T)	mg/l	5	27	0.004	5.0E-03	0.008	8.5E-03
	Copper (T)	mg/l	13	26	0.004	3.2E-02	0.31	2.0E-01

TABLE C-1.—NPDES Detection Statistics by Watershed (NPDES Data 1994 to 1996)-Continued

WATERSHED	ANALYTE ^a	UNITS ^b	DETECTED	ANALYZED	MINIMUM	MEAN	MAXIMUM	95% UCL ^c
Water (cont.)	Lead (T)	mg/l	6	27	0.0002	2.5E-03	0.004	5.1E-03
	Mercury (T)	mg/l	1	27	0.0003	3.0E-04	0.0003	
	Radium-226, Radium-228	pCi/l	27	27	0.0598	7.9E-01	3.414	2.8E+00
	Selenium (T)	mg/l	2	27	0.001	1.5E-03	0.002	2.9E-03
	Tritium	pCi/l	15	27	100	3.9E+02	1900	1.4E+03
	Vanadium (T)	mg/l	24	27	0.004	1.8E-02	0.12	6.4E-02
	Zinc (T)	mg/l	25	27	0.02	5.5E-02	0.15	1.3E-01

^a (T) signifies that the total amount of the analyte in the sample was measured, that is, both the dissolved amount and the amount adsorbed to suspended particles.

^b mg/l is milligrams of analyte per liter of sample; pCi/l is picocuries of radioactive analyte per liter of sample.

^c Upper confidence limit (UCL) not calculated for number of detected analyses less than two.

TABLE C-2.—Surface Water Detection Statistics by Location and Analyte
(Environmental Surveillance Report Data 1991 to 1996)

LOCATION ^a	ANALYTE	UNITS ^b	DETECTED	ANALYZED	MINIMUM	MEAN	MAXIMUM	95% UCL ^c
On Site	Acetone	µg/l	4	15	1.5E+01	3.2E+01	4.9E+01	6.1E+01
	Aluminum	µg/l	58	63	5.0E+01	4.2E+03	6.4E+04	2.4E+04
	Americium-241	pCi/l	46	52	6.0E-04	2.5E-01	2.2E+00	1.2E+00
	Antimony	µg/l	14	62	3.0E-01	8.9E-01	3.0E+00	2.5E+00
	Arsenic	µg/l	39	60	2.0E+00	5.0E+00	1.3E+01	1.0E+01
	Barium	µg/l	54	54	7.3E+00	1.1E+02	8.1E+02	4.7E+02
	Benzoic acid	µg/l	1	11	1.1E+01	1.1E+01	1.1E+01	
	Beryllium	µg/l	11	63	5.0E-01	1.3E+01	1.2E+02	8.4E+01
	Bicarbonate	mg/l	58	60	1.2E+01	9.6E+01	2.3E+02	1.8E+02
	Bis(2-ethylhexyl) phthalate	µg/l	2	11	8.0E+00	1.1E+01	1.4E+01	1.9E+01
	Boron	µg/l	60	63	1.1E+01	8.0E+01	4.0E+02	2.5E+02
	Bromine	µg/l	1	3	1.1E+02	1.1E+02	1.1E+02	
	Cadmium	µg/l	8	60	3.0E-01	2.1E+01	1.5E+02	1.3E+02
	Calcium	mg/l	63	63	7.3E+00	2.4E+01	1.9E+02	7.0E+01
	Carbonate	mg/l	12	60	2.0E+00	1.2E+01	2.8E+01	2.9E+01
	Cesium-137	pCi/l	64	93	1.1E-01	2.2E+01	3.3E+02	1.4E+02
	Chlorine	mg/l	60	60	2.0E+00	3.3E+01	1.1E+02	8.5E+01
	Chromium	µg/l	38	63	1.0E+00	3.3E+01	7.6E+02	2.8E+02
	Cobalt	µg/l	14	57	4.0E+00	2.8E+01	1.6E+02	1.1E+02
	Copper	µg/l	37	63	4.0E+00	3.7E+01	7.5E+02	2.8E+02
Cyanide	mg/l	13	48	1.0E-02	2.6E-02	1.1E-01	7.9E-02	
Di-n-butyl phthalate	µg/l	4	11	2.0E+00	6.3E+00	1.4E+01	1.8E+01	
Di-n-octyl phthalate	µg/l	1	11	8.0E+00	8.0E+00	8.0E+00		

TABLE C-2.—Surface Water Detection Statistics by Location and Analyte
(Environmental Surveillance Report Data 1991 to 1996)-Continued

LOCATION ^a	ANALYTE	UNITS ^b	DETECTED	ANALYZED	MINIMUM	MEAN	MAXIMUM	95% UCL ^c
On Site (cont.)	Fluorine	mg/l	58	60	1.0E-01	7.0E-01	2.5E+00	1.8E+00
	Gross Alpha	pCi/l	60	88	2.0E-01	7.6E+00	2.1E+02	6.4E+01
	Gross Beta	pCi/l	88	88	1.0E+00	2.7E+01	3.5E+02	1.3E+02
	Gross Gamma	pCi/l	52	86	1.0E+01	1.3E+02	6.0E+02	4.1E+02
	Hardness	mg/l	63	63	2.2E+01	7.8E+01	6.1E+02	2.3E+02
	HMX (Octogen)	µg/l	1	5	4.9E+00	4.9E+00	4.9E+00	
	Iron	µg/l	62	63	2.0E+01	3.1E+03	6.0E+04	2.0E+04
	Lead	µg/l	42	68	2.0E-01	7.4E+00	4.5E+01	2.8E+01
	Lithium	mg/l	11	13	4.0E-03	2.6E-02	5.9E-02	6.4E-02
	Magnesium	mg/l	63	63	1.3E+00	4.6E+00	3.3E+01	1.3E+01
	Manganese	µg/l	57	63	1.0E+00	1.6E+02	2.1E+03	8.2E+02
	Mercury	µg/l	16	62	1.0E-01	2.8E-01	1.0E+00	7.4E-01
	Molybdenum	µg/l	41	62	1.0E+00	2.5E+02	1.2E+03	8.6E+02
	Nickel	µg/l	12	63	2.0E+00	1.4E+02	7.9E+02	6.8E+02
	Nitrate, as Nitrogen	mg/l	50	63	3.0E-02	3.7E+00	2.0E+01	1.4E+01
	Nitrite, as Nitrogen	mg/l	1	3	4.6E-01	4.6E-01	4.6E-01	
	pH		60	60	3.6E+00		9.3E+00	
	Phosphate	mg/l	1	3	1.7E+00	1.7E+00	1.7E+00	
	Phosphate, as Phosphorous	mg/l	46	57	3.0E-02	1.8E+00	1.6E+01	7.4E+00
	Plutonium-238	pCi/l	116	176	1.0E-03	1.0E-01	4.7E+00	1.1E+00
	Plutonium-239, Plutonium-240	pCi/l	149	178	1.0E-03	7.3E-01	5.2E+01	1.0E+01
	Potassium	mg/l	58	58	1.2E+00	7.4E+00	4.3E+01	2.0E+01
	RDX (Cyclonite)	µg/l	1	6	7.6E-01	7.6E-01	7.6E-01	

TABLE C-2.—Surface Water Detection Statistics by Location and Analyte
(Environmental Surveillance Report Data 1991 to 1996)-Continued

LOCATION ^a	ANALYTE	UNITS ^b	DETECTED	ANALYZED	MINIMUM	MEAN	MAXIMUM	95% UCL ^c
On Site (cont.)	Selenium	µg/l	12	63	1.0E+00	6.3E+01	6.7E+02	4.5E+02
	Silica	mg/l	66	67	1.5E+01	6.1E+01	1.7E+02	1.2E+02
	Silver	µg/l	20	63	5.0E-01	4.8E+01	6.9E+02	3.5E+02
	Sodium	mg/l	63	63	5.0E+00	4.8E+01	1.8E+02	1.2E+02
	Strontium	µg/l	63	63	4.7E+01	1.2E+02	9.1E+02	3.9E+02
	Strontium-90	pCi/l	44	51	6.0E-02	2.7E+01	7.0E+02	2.4E+02
	Sulfate	mg/l	60	60	2.0E+00	2.9E+01	1.1E+02	9.3E+01
	Thallium	µg/l	11	63	1.7E-01	8.4E-01	6.0E+00	4.3E+00
	Tin	µg/l	14	58	1.0E+01	5.6E+01	2.4E+02	1.9E+02
	Total Dissolved Solids	mg/l	60	60	9.0E+01	3.5E+02	1.8E+03	8.4E+02
	Total Suspended Solids	mg/l	50	54	1.2E+00	7.3E+02	1.5E+04	5.3E+03
	Tritium	nCi/l	71	96	1.0E-04	1.2E+00	1.8E+01	7.7E+00
	Uranium	µg/l	63	79	6.0E-02	8.0E-01	9.5E+00	3.4E+00
	Vanadium	µg/l	44	63	1.0E+00	2.1E+01	9.0E+01	6.0E+01
	Zinc	µg/l	50	62	5.0E+00	7.3E+01	4.2E+02	2.2E+02
	Acetone	µg/l	4	12	2.3E+01	2.6E+01	3.2E+01	3.4E+01
	Perimeter	Aluminum	µg/l	38	47	1.0E+01	9.5E+02	3.3E+03
Americium-241		pCi/l	24	32	7.0E-03	5.4E-02	1.7E-01	1.5E-01
Antimony		µg/l	6	47	2.0E-01	4.8E-01	1.2E+00	1.2E+00
Arsenic		µg/l	22	46	2.0E+00	3.5E+00	7.8E+00	6.8E+00
Barium		µg/l	39	40	6.8E+00	1.8E+02	5.2E+03	1.8E+03
Beryllium		µg/l	9	47	5.0E-01	1.4E+02	1.2E+03	9.4E+02
Bicarbonate		mg/l	47	48	2.4E+01	6.3E+01	1.5E+02	1.2E+02

TABLE C-2.—Surface Water Detection Statistics by Location and Analyte
(Environmental Surveillance Report Data 1991 to 1996)-Continued

LOCATION ^a	ANALYTE	UNITS ^b	DETECTED	ANALYZED	MINIMUM	MEAN	MAXIMUM	95% UCL ^c
Perimeter (cont.)	Bis(2-ethylhexyl) phthalate	µg/l	1	8	2.0E+00	2.0E+00	2.0E+00	
	Boron	µg/l	29	47	1.0E+01	2.5E+02	4.2E+03	1.8E+03
	Cadmium	µg/l	10	47	2.0E-01	1.2E+02	1.0E+03	7.4E+02
	Calcium	mg/l	46	48	6.0E+00	3.2E+01	8.1E+02	2.7E+02
	Carbonate	mg/l	3	48	4.0E+00	8.3E+00	1.2E+01	1.6E+01
	Cesium-137	pCi/l	39	57	2.0E-02	3.0E+01	3.2E+02	1.6E+02
	Chlorine	mg/l	47	48	9.2E-01	2.7E+01	2.1E+02	1.1E+02
	Chromium	µg/l	21	47	2.0E+00	2.7E+02	5.0E+03	2.4E+03
	Cobalt	µg/l	5	42	3.0E+00	2.1E+02	8.5E+02	9.4E+02
	Copper	µg/l	22	48	2.0E+00	1.1E+03	1.7E+04	8.7E+03
	Cyanide	mg/l	6	36	1.0E-02	1.3E-02	2.0E-02	2.4E-02
	Di-n-butyl phthalate	µg/l	1	8	4.0E+00	4.0E+00	4.0E+00	
	Dinitrotoluene [2,4-]	µg/l	1	10	3.4E+00	3.4E+00	3.4E+00	
	Fluorine	mg/l	44	48	6.0E-02	3.4E-01	1.1E+00	8.5E-01
	Gross Alpha	pCi/l	35	51	5.0E-02	1.9E+00	2.5E+01	1.0E+01
	Gross Beta	pCi/l	49	51	1.0E+00	9.3E+00	1.4E+02	4.9E+01
	Gross Gamma	pCi/l	36	54	1.0E+01	1.6E+02	9.0E+02	5.6E+02
	Hardness	mg/l	47	49	1.0E+01	5.0E+01	1.1E+02	1.0E+02
	Iron	µg/l	43	47	2.0E+01	6.1E+02	2.2E+03	1.8E+03
	Lead	µg/l	21	48	5.0E-01	4.6E+00	5.5E+01	2.8E+01
Lithium	mg/l	8	9	1.0E-02	2.0E-02	3.0E-02	3.7E-02	
Magnesium	mg/l	46	48	1.2E+00	3.6E+00	8.8E+00	7.1E+00	
Manganese	µg/l	40	47	2.0E+00	1.7E+02	5.4E+03	1.9E+03	

TABLE C-2.—Surface Water Detection Statistics by Location and Analyte
(Environmental Surveillance Report Data 1991 to 1996)-Continued

LOCATION ^a	ANALYTE	UNITS ^b	DETECTED	ANALYZED	MINIMUM	MEAN	MAXIMUM	95% UCL ^c
Perimeter (cont.)	Mercury	µg/l	5	46	1.0E-01	2.2E-01	4.0E-01	5.5E-01
	Methylene chloride	µg/l	1	12	2.0E+01	2.0E+01	2.0E+01	
	Molybdenum	µg/l	12	45	1.0E+00	1.0E+02	1.0E+03	6.7E+02
	Nickel	µg/l	6	47	1.0E+01	9.9E+02	5.5E+03	5.4E+03
	Nitrate, as Nitrogen	mg/l	37	52	4.5E-03	1.9E+00	1.7E+01	8.6E+00
	pH		48	48	1.7E+00		8.6E+00	
	Phosphate	mg/l	1	3	1.1E-01	1.1E-01	1.1E-01	
	Phosphate, as Phosphorous	mg/l	31	45	2.0E-02	1.4E+00	9.0E+00	6.5E+00
	Plutonium-238	pCi/l	64	103	1.0E-03	2.3E-02	2.3E-01	9.8E-02
	Plutonium-239, Plutonium-240	pCi/l	87	103	3.0E-03	5.8E-01	1.2E+01	4.6E+00
	Potassium	mg/l	41	46	5.7E-01	5.0E+00	1.7E+01	1.5E+01
	Selenium	µg/l	6	46	2.0E+00	4.7E+00	7.0E+00	9.2E+00
	Silica	mg/l	51	51	1.7E+01	5.3E+01	9.9E+01	9.7E+01
	Silver	µg/l	9	47	4.0E-01	5.9E+01	3.7E+02	3.0E+02
	Sodium	mg/l	46	48	3.0E+00	2.9E+01	8.5E+01	8.5E+01
	Strontium	µg/l	46	47	3.8E+01	2.0E+02	5.3E+03	1.7E+03
	Strontium-90	pCi/l	21	32	1.0E-01	5.4E+01	5.0E+02	3.5E+02
	Sulfate	mg/l	48	48	2.5E+00	1.1E+01	3.5E+01	3.1E+01
	Thallium	µg/l	2	47	1.0E-01	2.0E-01	3.0E-01	4.8E-01
	Tin	µg/l	5	33	3.0E+01	2.2E+02	9.2E+02	1.0E+03
	Total Dissolved Solids	mg/l	48	48	6.6E+01	2.6E+02	1.1E+03	6.8E+02
	Total Suspended Solids	mg/l	26	32	2.0E+00	1.9E+03	1.4E+04	9.4E+03

TABLE C-2.—Surface Water Detection Statistics by Location and Analyte
(Environmental Surveillance Report Data 1991 to 1996)-Continued

LOCATION ^a	ANALYTE	UNITS ^b	DETECTED	ANALYZED	MINIMUM	MEAN	MAXIMUM	95% UCL ^c
Perimeter (cont.)	Trinitrotoluene [2,4,6-]	µg/l	1	2	1.4E+00	1.4E+00	1.4E+00	
	Tritium	nCi/l	44	59	1.0E-04	4.2E-01	1.7E+00	1.2E+00
	Uranium	µg/l	39	56	6.0E-02	5.6E-01	2.7E+00	1.7E+00
	Vanadium	µg/l	26	47	3.0E+00	5.1E+01	1.0E+03	4.4E+02
	Zinc	µg/l	28	47	4.0E+00	9.2E+01	1.3E+03	5.8E+02
	Aluminum	µg/l	36	36	2.0E+02	2.9E+03	1.4E+04	8.9E+03
	Americium-241	pCi/l	21	29	4.0E-03	3.2E-02	6.8E-02	6.7E-02
	Antimony	µg/l	4	36	1.0E-01	3.1E+00	9.0E+00	1.1E+01
	Arsenic	µg/l	24	35	2.0E+00	1.1E+01	6.3E+01	4.2E+01
	Barium	µg/l	30	30	4.5E+01	1.3E+02	1.0E+03	4.8E+02
Regional	Beryllium	µg/l	5	36	3.0E+00	1.3E+01	5.0E+01	5.4E+01
	Bicarbonate	mg/l	42	42	5.9E+01	9.0E+01	1.7E+02	1.4E+02
	Boron	µg/l	34	36	1.0E+01	7.4E+01	5.7E+02	3.1E+02
	Cadmium	µg/l	2	36	3.0E+00	2.7E+01	5.1E+01	9.5E+01
	Calcium	mg/l	42	42	2.0E+01	4.0E+01	2.1E+02	9.6E+01
	Carbonate	mg/l	1	42	1.6E+01	1.6E+01	1.6E+01	
	Cesium-137	pCi/l	30	41	2.1E-01	4.9E+01	2.3E+02	1.9E+02
	Chlorine	mg/l	42	42	2.1E+00	9.5E+00	7.5E+01	3.6E+01
	Chromium	µg/l	19	36	2.0E+00	2.4E+01	2.5E+02	1.4E+02
	Cobalt	µg/l	5	30	4.0E+00	2.0E+01	5.0E+01	5.9E+01
	Copper	µg/l	10	36	2.0E+00	4.2E+01	2.4E+02	1.9E+02
	Cyanide	mg/l	3	30	1.0E-02	1.0E-02	1.0E-02	1.0E-02
	Fluorine	mg/l	42	42	1.0E-01	3.4E-01	1.0E+00	7.1E-01
	Gross Alpha	pCi/l	33	36	4.0E-01	3.2E+00	1.5E+01	9.6E+00
	Gross Beta	pCi/l	36	36	1.0E+00	1.0E+01	1.2E+02	5.2E+01

TABLE C-2.—Surface Water Detection Statistics by Location and Analyte
(Environmental Surveillance Report Data 1991 to 1996)-Continued

LOCATION ^a	ANALYTE	UNITS ^b	DETECTED	ANALYZED	MINIMUM	MEAN	MAXIMUM	95% UCL ^c
Regional (cont.)	Gross Gamma	pCi/l	27	42	1.0E+01	1.5E+02	5.5E+02	4.9E+02
	Hardness	mg/l	42	42	5.0E+01	1.2E+02	1.7E+02	1.7E+02
	Iron	µg/l	36	36	1.4E+02	2.2E+03	1.3E+04	6.8E+03
	Lead	µg/l	22	36	1.0E+00	4.9E+00	1.9E+01	1.4E+01
	Lithium	mg/l	6	10	1.5E-02	3.9E-02	1.4E-01	1.4E-01
	Magnesium	mg/l	42	42	2.6E+00	7.0E+00	1.6E+01	1.2E+01
	Manganese	µg/l	36	36	2.0E+00	1.5E+02	1.6E+03	6.8E+02
	Mercury	µg/l	5	36	1.0E-01	1.2E-01	2.0E-01	2.1E-01
	Molybdenum	µg/l	14	36	2.0E+00	2.7E+02	2.4E+03	1.6E+03
	Nickel	µg/l	11	36	2.0E+00	6.4E+01	3.0E+02	2.8E+02
	Nitrate, as Nitrogen	mg/l	40	48	1.4E-02	1.2E+00	9.7E+00	6.5E+00
	pH		42	42	7.0E+00		8.8E+00	
	Phosphate	mg/l	1	6	2.6E-01	2.6E-01	2.6E-01	
	Phosphate, as Phosphorous	mg/l	23	42	3.0E-02	1.1E-01	2.0E-01	2.3E-01
	Plutonium-238	pCi/l	29	48	3.0E-03	1.8E-02	1.1E-01	5.9E-02
	Plutonium-239, Plutonium-240	pCi/l	33	48	2.0E-04	1.7E-02	9.2E-02	5.8E-02
	Potassium	mg/l	42	42	2.0E+00	3.1E+00	1.1E+01	6.4E+00
	Selenium	µg/l	12	36	2.0E+00	3.7E+00	8.0E+00	7.9E+00
	Silica	mg/l	48	48	1.4E+01	2.3E+01	4.4E+01	3.9E+01
	Silver	µg/l	2	36	1.0E+00	4.5E+01	8.8E+01	1.7E+02
Sodium	mg/l	42	42	9.4E+00	1.9E+01	6.0E+01	3.6E+01	
Strontium	µg/l	36	36	8.3E+01	2.9E+02	1.0E+03	5.9E+02	
Strontium-90	pCi/l	24	29	1.0E-01	7.0E-01	3.3E+00	2.0E+00	
Sulfate	mg/l	42	42	6.0E+00	4.4E+01	1.1E+02	8.8E+01	

TABLE C-2.—Surface Water Detection Statistics by Location and Analyte
(Environmental Surveillance Report Data 1991 to 1996)-Continued

LOCATION ^a	ANALYTE	UNITS ^b	DETECTED	ANALYZED	MINIMUM	MEAN	MAXIMUM	95% UCL ^c
Regional (cont.)	Thallium	µg/l	1	36	2.0E-01	2.0E-01	2.0E-01	
	Tin	µg/l	1	30	3.3E+01	3.3E+01	3.3E+01	
	Total Dissolved Solids	mg/l	42	42	8.6E+01	2.5E+02	7.2E+02	4.6E+02
	Total Suspended Solids	mg/l	14	18	1.2E+01	1.7E+02	1.3E+03	8.4E+02
	Tritium	nCi/l	28	42	1.0E-04	2.4E-01	6.0E-01	6.3E-01
	Uranium	µg/l	41	43	2.0E-01	1.7E+00	3.9E+00	3.5E+00
	Vanadium	µg/l	30	36	2.0E+00	1.6E+01	1.3E+02	6.1E+01
	Zinc	µg/l	26	36	6.0E+00	4.1E+01	2.1E+02	1.3E+02

^a On-site, perimeter, and regional locations are in accordance with the Environmental Surveillance Program.

^b pCi/l is picocuries of radioactive analyte per liter of sample, nCi/l is nanocuries of radioactive analyte per liter of sample, µg/l is micrograms of analyte per liter of sample, mg/l is milligrams of analyte per liter of sample.

^c Upper confidence limit (UCL) not calculated when the number of detected analyses equals 1.

**TABLE C-3.—Surface Water Detection Statistics by Watershed and Analyte
(Environmental Surveillance Report Data 1991 to 1996)**

WATERSHED ^a	ANALYTE	UNITS ^b	DETECTED	ANALYZED	MINIMUM	MEAN	MAXIMUM	95% UCL ^c
Ancho	Acetone	µg/l	2	2	2.5E+01	3.2E+01	3.8E+01	5.0E+01
	Aluminum	µg/l	5	7	5.0E+01	1.7E+03	7.0E+03	7.7E+03
	Americium-241	pCi/l	4	6	3.0E-03	3.0E-02	4.3E-02	6.6E-02
	Arsenic	µg/l	4	7	2.0E+00	3.0E+00	4.0E+00	4.6E+00
	Barium	µg/l	6	6	2.7E+01	1.6E+02	8.1E+02	8.0E+02
	Bicarbonate	mg/l	6	7	5.5E+01	6.5E+01	7.5E+01	7.8E+01
	Boron	µg/l	7	7	1.1E+01	5.2E+01	2.3E+02	2.1E+02
	Calcium	mg/l	7	7	7.3E+00	1.3E+01	1.6E+01	1.9E+01
	Carbonate	mg/l	4	7	1.4E+01	1.7E+01	2.3E+01	2.5E+01
	Cesium-137	pCi/l	5	9	1.1E-01	1.4E+00	3.3E+00	3.8E+00
	Chlorine	mg/l	7	7	2.0E+00	4.5E+00	8.3E+00	8.9E+00
	Chromium	µg/l	4	7	1.0E+00	4.8E+00	7.7E+00	1.1E+01
	Copper	µg/l	2	7	6.0E+00	6.5E+00	7.0E+00	7.9E+00
	Di-n-butyl phthalate	µg/l	1	2	1.4E+01	1.4E+01	1.4E+01	
	Fluorine	mg/l	7	7	2.5E-01	3.8E-01	4.0E-01	4.9E-01
	Gross Alpha	pCi/l	5	8	1.0E+00	5.7E+00	2.3E+01	2.5E+01
	Gross Beta	pCi/l	8	8	2.0E+00	1.4E+01	7.3E+01	6.3E+01
	Gross Gamma	pCi/l	4	8	8.0E+01	2.0E+02	4.6E+02	5.5E+02
	Hardness	mg/l	7	7	2.7E+01	4.7E+01	5.6E+01	6.6E+01
	Iron	µg/l	6	7	5.0E+01	8.3E+02	3.6E+03	3.6E+03
Lead	µg/l	3	7	2.0E-01	2.7E+00	6.0E+00	8.7E+00	
Lithium	mg/l	1	1	2.2E-02	2.2E-02	2.2E-02		
Magnesium	mg/l	7	7	2.2E+00	3.3E+00	4.0E+00	4.5E+00	
Manganese	µg/l	6	7	1.0E+00	3.4E+01	1.4E+02	1.4E+02	

TABLE C-3.—Surface Water Detection Statistics by Watershed and Analyte
(Environmental Surveillance Report Data 1991 to 1996)-Continued

WATERSHED ^a	ANALYTE	UNITS ^b	DETECTED	ANALYZED	MINIMUM	MEAN	MAXIMUM	95% UCL ^c
Ancho (cont.)	Molybdenum	µg/l	1	6	1.0E+01	1.0E+01	1.0E+01	
	Nitrate, as Nitrogen	mg/l	2	6	4.0E-02	4.8E-01	9.1E-01	1.7E+00
	pH		7	7	6.9E+00		9.3E+00	
	Phosphate, as Phosphorous	mg/l	2	6	3.0E-02	1.7E-01	3.0E-01	5.5E-01
	Plutonium-238	pCi/l	10	13	2.0E-03	6.7E-03	2.0E-02	1.8E-02
	Plutonium-239, Plutonium-240	pCi/l	10	13	2.0E-03	1.2E-02	3.9E-02	3.6E-02
	Potassium	mg/l	7	7	1.2E+00	2.5E+00	4.8E+00	4.8E+00
	Selenium	µg/l	2	7	1.0E+00	2.0E+00	3.0E+00	4.8E+00
	Silica	mg/l	7	7	1.5E+01	6.7E+01	8.1E+01	1.1E+02
	Sodium	mg/l	7	7	5.0E+00	1.0E+01	1.2E+01	1.5E+01
	Strontium	µg/l	7	7	4.7E+01	6.6E+01	7.6E+01	8.7E+01
	Strontium-90	pCi/l	6	7	9.0E-01	1.3E+02	7.0E+02	6.9E+02
	Sulfate	mg/l	7	7	2.0E+00	4.6E+00	8.7E+00	8.8E+00
	Tin	µg/l	2	5	3.6E+01	3.7E+01	3.8E+01	4.0E+01
	Total Dissolved Solids	mg/l	7	7	9.0E+01	3.8E+02	1.8E+03	1.6E+03
	Total Suspended Solids	mg/l	3	4	1.2E+00	1.6E+03	4.6E+03	6.8E+03
	Tritium	nCi/l	5	9	1.0E-01	3.4E-01	6.0E-01	7.0E-01
	Uranium	µg/l	8	9	2.2E-01	1.7E+00	9.5E+00	8.0E+00
	Vanadium	µg/l	7	7	6.0E+00	9.2E+00	1.1E+01	1.3E+01
	Zinc	µg/l	3	7	2.4E+01	1.1E+02	2.3E+02	3.2E+02

**TABLE C-3.—Surface Water Detection Statistics by Watershed and Analyte
(Environmental Surveillance Report Data 1991 to 1996)-Continued**

WATERSHED ^a	ANALYTE	UNITS ^b	DETECTED	ANALYZED	MINIMUM	MEAN	MAXIMUM	95% UCL ^c
Cañada del Buey	Aluminum	µg/l	6	6	3.0E+02	1.2E+04	3.5E+04	3.9E+04
	Americium-241	pCi/l	2	3	2.3E-02	3.9E-02	5.5E-02	8.4E-02
	Antimony	µg/l	1	6	3.0E-01	3.0E-01	3.0E-01	
	Arsenic	µg/l	4	5	3.2E+00	4.5E+00	5.8E+00	6.8E+00
	Barium	µg/l	5	5	1.2E+02	2.1E+02	4.8E+02	5.1E+02
	Beryllium	µg/l	2	6	1.0E+00	2.0E+00	2.9E+00	4.6E+00
	Bicarbonate	mg/l	5	6	1.2E+01	4.9E+01	7.7E+01	9.7E+01
	Boron	µg/l	6	6	5.0E+01	6.3E+01	7.5E+01	8.3E+01
	Calcium	mg/l	6	6	1.0E+01	1.2E+01	1.6E+01	1.6E+01
	Cesium-137	pCi/l	3	5	1.1E+00	4.6E+00	1.0E+01	1.4E+01
	Chlorine	mg/l	5	6	7.0E+00	2.1E+01	5.7E+01	6.2E+01
	Chromium	µg/l	5	6	7.2E+00	1.7E+01	2.7E+01	3.1E+01
	Cobalt	µg/l	2	5	6.0E+00	8.0E+00	1.0E+01	1.4E+01
	Copper	µg/l	6	7	6.0E+00	2.9E+03	1.7E+04	1.7E+04
	Cyanide	mg/l	2	5	2.0E-02	2.0E-02	2.0E-02	2.0E-02
	Fluorine	mg/l	5	6	4.7E-01	5.1E-01	6.0E-01	6.1E-01
	Gross Alpha	pCi/l	5	5	3.2E-01	1.8E+00	3.0E+00	4.2E+00
	Gross Beta	pCi/l	5	5	5.0E+00	6.5E+00	1.0E+01	1.1E+01
	Gross Gamma	pCi/l	3	6	6.0E+01	1.8E+02	2.9E+02	4.0E+02
	Hardness	mg/l	6	7	2.2E+01	4.1E+01	5.5E+01	6.7E+01
Iron	µg/l	6	6	7.2E+02	7.2E+03	1.8E+04	2.1E+04	
Lead	µg/l	5	6	2.0E+00	9.5E+00	1.3E+01	1.8E+01	
Lithium	mg/l	1	1	4.1E-02	4.1E-02	4.1E-02		
Magnesium	mg/l	6	6	1.2E+00	3.5E+00	5.5E+00	6.6E+00	
Manganese	µg/l	6	6	1.2E+01	2.5E+02	5.2E+02	6.6E+02	
Mercury	µg/l	3	5	3.0E-01	3.7E-01	4.0E-01	4.8E-01	

TABLE C-3.—Surface Water Detection Statistics by Watershed and Analyte
(Environmental Surveillance Report Data 1991 to 1996)-Continued

WATERSHED ^a	ANALYTE	UNITS ^b	DETECTED	ANALYZED	MINIMUM	MEAN	MAXIMUM	95% UCL ^c
Cañada del Buey (cont.)	Molybdenum	µg/l	5	6	1.0E+02	2.0E+02	5.0E+02	5.4E+02
	Nickel	µg/l	1	6	1.0E+01	1.0E+01	1.0E+01	
	Nitrate, as Nitrogen	mg/l	6	7	8.0E-02	1.8E+00	6.0E+00	6.2E+00
	pH		6	6	3.6E+00		8.4E+00	
	Phosphate, as Phosphorous	mg/l	5	6	8.0E-02	3.4E-01	7.0E-01	9.4E-01
	Plutonium-238	pCi/l	2	6	6.0E-03	6.5E-03	7.0E-03	7.9E-03
	Plutonium-239, Plutonium-240	pCi/l	6	6	8.0E-03	1.6E-02	4.4E-02	4.4E-02
	Potassium	mg/l	4	5	3.0E+00	4.7E+00	7.3E+00	8.6E+00
	Silica	mg/l	7	7	1.8E+01	5.1E+01	1.7E+02	1.6E+02
	Silver	µg/l	4	6	1.2E+00	9.1E+00	2.0E+01	2.7E+01
	Sodium	mg/l	6	6	3.0E+00	2.0E+01	3.4E+01	4.0E+01
	Strontium	µg/l	6	6	4.9E+01	7.2E+01	9.0E+01	9.9E+01
	Strontium-90	pCi/l	2	3	1.1E+00	1.1E+00	1.1E+00	1.1E+00
	Sulfate	mg/l	6	6	2.5E+00	1.9E+01	6.2E+01	6.5E+01
	Thallium	µg/l	1	6	2.0E-01	2.0E-01	2.0E-01	
	Tin	µg/l	1	6	4.0E+01	4.0E+01	4.0E+01	
	Total Dissolved Solids	mg/l	6	6	1.8E+02	3.1E+02	4.5E+02	5.3E+02
	Total Suspended Solids	mg/l	2	2	3.5E+01	4.6E+03	9.1E+03	1.7E+04
	Tritium	nCi/l	4	6	5.0E-04	4.0E-01	7.0E-01	1.0E+00
	Uranium	µg/l	5	6	2.2E-01	6.1E-01	1.3E+00	1.6E+00
Vanadium	µg/l	5	6	3.0E+00	2.0E+01	3.7E+01	4.8E+01	
Zinc	µg/l	6	6	3.0E+01	8.4E+01	1.2E+02	1.6E+02	

TABLE C-3.—Surface Water Detection Statistics by Watershed and Analyte
(Environmental Surveillance Report Data 1991 to 1996)-Continued

WATERSHED ^a	ANALYTE	UNITS ^b	DETECTED	ANALYZED	MINIMUM	MEAN	MAXIMUM	95% UCL ^c
Chaquehui	Aluminum	µg/l	1	1	6.4E+04	6.4E+04	6.4E+04	
	Americium-241	pCi/l	1	1	6.0E-02	6.0E-02	6.0E-02	
	Barium	µg/l	1	1	6.2E+02	6.2E+02	6.2E+02	
	Beryllium	µg/l	1	1	5.0E+00	5.0E+00	5.0E+00	
	Bicarbonate	mg/l	1	1	6.0E+01	6.0E+01	6.0E+01	
	Calcium	mg/l	1	1	2.7E+01	2.7E+01	2.7E+01	
	Chlorine	mg/l	1	1	3.0E+00	3.0E+00	3.0E+00	
	Chromium	µg/l	1	1	3.6E+01	3.6E+01	3.6E+01	
	Cobalt	µg/l	1	1	1.4E+01	1.4E+01	1.4E+01	
	Copper	µg/l	1	1	3.3E+01	3.3E+01	3.3E+01	
	Fluorine	mg/l	1	1	5.0E-01	5.0E-01	5.0E-01	
	Gross Alpha	pCi/l	1	1	2.0E+00	2.0E+00	2.0E+00	
	Gross Beta	pCi/l	1	1	2.0E+00	2.0E+00	2.0E+00	
	Hardness	mg/l	1	1	4.1E+01	4.1E+01	4.1E+01	
	Iron	µg/l	1	1	6.0E+04	6.0E+04	6.0E+04	
	Lead	µg/l	1	1	3.0E+00	3.0E+00	3.0E+00	
	Magnesium	mg/l	1	1	1.2E+01	1.2E+01	1.2E+01	
	Manganese	µg/l	1	1	8.7E+02	8.7E+02	8.7E+02	
	Nickel	µg/l	1	1	2.4E+01	2.4E+01	2.4E+01	
	pH		1	1	7.9E+00		7.9E+00	
	Plutonium-238	pCi/l	1	1	2.0E-02	2.0E-02	2.0E-02	
	Plutonium-239, Plutonium-240	pCi/l	1	1	2.9E-02	2.9E-02	2.9E-02	
	Potassium	mg/l	1	1	1.0E+01	1.0E+01	1.0E+01	
Silica	mg/l	1	1	8.0E+01	8.0E+01	8.0E+01		
Sodium	mg/l	1	1	7.0E+00	7.0E+00	7.0E+00		

TABLE C-3.—Surface Water Detection Statistics by Watershed and Analyte
(Environmental Surveillance Report Data 1991 to 1996)-Continued

WATERSHED ^a	ANALYTE	UNITS ^b	DETECTED	ANALYZED	MINIMUM	MEAN	MAXIMUM	95% UCL ^c
Chaquehui (cont.)	Strontium	µg/l	1	1	6.0E+01	6.0E+01	6.0E+01	
	Strontium-90	pCi/l	1	1	1.9E+00	1.9E+00	1.9E+00	
	Sulfate	mg/l	1	1	3.0E+00	3.0E+00	3.0E+00	
	Total Dissolved Solids	mg/l	1	1	1.4E+02	1.4E+02	1.4E+02	
	Tritium	nCi/l	1	1	3.0E-01	3.0E-01	3.0E-01	
	Uranium	µg/l	1	1	1.4E+00	1.4E+00	1.4E+00	
	Vanadium	µg/l	1	1	6.0E+01	6.0E+01	6.0E+01	
	Zinc	µg/l	1	1	2.3E+02	2.3E+02	2.3E+02	
	Acetone	µg/l	2	4	2.3E+01	2.4E+01	2.5E+01	2.7E+01
	Aluminum	µg/l	10	13	1.2E+02	5.2E+02	1.8E+03	1.7E+03
Frijoles	Americium-241	pCi/l	8	8	7.0E-03	4.7E-02	1.7E-01	1.5E-01
	Antimony	µg/l	1	13	4.0E-01	4.0E-01	4.0E-01	
	Arsenic	µg/l	3	13	2.0E+00	2.3E+00	3.0E+00	3.5E+00
	Barium	µg/l	10	11	1.6E+01	2.0E+01	2.8E+01	2.8E+01
	Beryllium	µg/l	1	13	5.0E-01	5.0E-01	5.0E-01	
	Bicarbonate	mg/l	13	13	3.3E+01	5.1E+01	7.6E+01	7.3E+01
	Boron	µg/l	6	13	1.0E+01	1.5E+01	2.0E+01	2.3E+01
	Cadmium	µg/l	2	13	2.0E-01	1.6E+00	3.0E+00	5.6E+00
	Calcium	mg/l	12	13	8.0E+00	7.6E+01	8.1E+02	5.4E+02
	Carbonate	mg/l	1	13	4.0E+00	4.0E+00	4.0E+00	
	Cesium-137	pCi/l	7	14	4.0E-01	2.8E+01	9.5E+01	1.2E+02
	Chlorine	mg/l	13	13	3.0E+00	6.6E+00	3.2E+01	2.2E+01
	Chromium	µg/l	4	13	2.0E+00	3.5E+00	6.0E+00	7.3E+00
	Cobalt	µg/l	1	11	3.0E+00	3.0E+00	3.0E+00	
	Copper	µg/l	3	13	2.0E+00	5.7E+00	1.3E+01	1.8E+01

TABLE C-3.—Surface Water Detection Statistics by Watershed and Analyte
(Environmental Surveillance Report Data 1991 to 1996)-Continued

WATERSHED ^a	ANALYTE	UNITS ^b	DETECTED	ANALYZED	MINIMUM	MEAN	MAXIMUM	95% UCL ^c
Frijoles (cont.)	Cyanide	mg/l	1	11	1.0E-02	1.0E-02	1.0E-02	
	Dinitrotoluene [2,4-]	µg/l	1	4	3.4E+00	3.4E+00	3.4E+00	
	Fluorine	mg/l	12	13	9.0E-02	1.9E-01	3.0E-01	3.2E-01
	Gross Alpha	pCi/l	7	12	7.0E-01	4.7E+00	2.5E+01	2.3E+01
	Gross Beta	pCi/l	10	12	1.7E+00	3.2E+00	8.0E+00	7.1E+00
	Gross Gamma	pCi/l	6	11	4.0E+01	2.5E+02	7.0E+02	7.4E+02
	Hardness	mg/l	12	13	2.2E+01	3.7E+01	4.7E+01	4.9E+01
	Iron	µg/l	11	13	1.2E+02	3.4E+02	9.6E+02	8.8E+02
	Lead	µg/l	5	14	1.0E+00	1.2E+01	5.5E+01	6.0E+01
	Lithium	mg/l	3	3	1.0E-02	1.6E-02	2.3E-02	2.9E-02
	Magnesium	mg/l	12	13	2.7E+00	3.2E+00	3.5E+00	3.6E+00
	Manganese	µg/l	10	13	2.0E+00	1.6E+01	3.6E+01	4.2E+01
	Methylene chloride	µg/l	1	4	2.0E+01	2.0E+01	2.0E+01	
	Molybdenum	µg/l	2	12	1.0E+00	7.0E+00	1.3E+01	2.4E+01
	Nickel	µg/l	2	13	2.3E+01	3.9E+01	5.4E+01	8.2E+01
	Nitrate, as Nitrogen	mg/l	7	14	9.0E-03	4.3E-01	2.0E+00	1.9E+00
	pH			13	7.3E+00		8.4E+00	
	Phosphate, as Phosphorous	mg/l		7	5.0E-02	1.5E-01	3.0E-01	3.6E-01
	Plutonium-238	pCi/l		11	3.0E-03	1.2E-02	3.1E-02	3.0E-02
	Plutonium-239, Plutonium-240	pCi/l		9	3.0E-03	8.4E-03	1.6E-02	1.6E-02
	Potassium	mg/l		11	5.7E-01	2.0E+00	3.0E+00	3.3E+00
	Selenium	µg/l		2	2.0E+00	2.5E+00	3.0E+00	3.9E+00

TABLE C-3.—Surface Water Detection Statistics by Watershed and Analyte
(Environmental Surveillance Report Data 1991 to 1996)-Continued

WATERSHED ^a	ANALYTE	UNITS ^b	DETECTED	ANALYZED	MINIMUM	MEAN	MAXIMUM	95% UCL ^c
Frijoles (cont.)	Silica	mg/l	14	14	4.8E+01	6.0E+01	9.0E+01	8.1E+01
	Sodium	mg/l	12	13	7.9E+00	1.0E+01	1.2E+01	1.3E+01
	Strontium	µg/l	12	13	5.0E+01	5.8E+01	6.6E+01	6.7E+01
	Strontium-90	pCi/l	6	8	1.0E-01	8.4E+01	5.0E+02	4.9E+02
	Sulfate	mg/l	13	13	3.0E+00	6.1E+00	3.2E+01	2.2E+01
	Tin	µg/l	1	9	3.5E+01	3.5E+01	3.5E+01	
	Total Dissolved Solids	mg/l	13	13	9.0E+01	2.2E+02	9.9E+02	6.9E+02
	Total Suspended Solids	mg/l	4	5	2.0E+00	7.4E+00	1.9E+01	2.3E+01
	Trinitrotoluene [2,4,6-]	µg/l	1	1	1.4E+00	1.4E+00	1.4E+00	
	Tritium	nCi/l	10	14	1.0E-04	2.9E-01	8.0E-01	7.9E-01
	Uranium	µg/l	9	13	8.0E-02	4.5E-01	1.3E+00	1.3E+00
	Vanadium	µg/l	7	13	4.0E+00	8.3E+00	1.3E+01	1.5E+01
	Zinc	µg/l	6	13	9.0E+00	2.9E+01	6.4E+01	7.0E+01
	Aluminum	µg/l	4	5	1.1E+02	9.5E+02	2.3E+03	3.0E+03
Guaje	Americium-241	pCi/l	1	2	4.3E-02	4.3E-02	4.3E-02	
	Arsenic	µg/l	1	5	2.0E+00	2.0E+00	2.0E+00	
	Barium	µg/l	4	4	1.8E+01	2.3E+01	3.0E+01	3.3E+01
	Bicarbonate	mg/l	5	5	3.0E+01	3.7E+01	4.3E+01	4.6E+01
	Boron	µg/l	1	5	1.0E+01	1.0E+01	1.0E+01	
	Calcium	mg/l	5	5	7.0E+00	7.9E+00	1.0E+01	1.0E+01
	Cesium-137	pCi/l	3	5	4.0E-01	3.5E+01	1.0E+02	1.5E+02
	Chlorine	mg/l	5	5	9.2E-01	2.5E+00	6.7E+00	7.3E+00
	Chromium	µg/l	1	5	2.0E+00	2.0E+00	2.0E+00	
	Copper	µg/l	1	5	4.0E+00	4.0E+00	4.0E+00	

**TABLE C-3.—Surface Water Detection Statistics by Watershed and Analyte
(Environmental Surveillance Report Data 1991 to 1996)-Continued**

WATERSHED ^a	ANALYTE	UNITS ^b	DETECTED	ANALYZED	MINIMUM	MEAN	MAXIMUM	95% UCL ^c
Guaje (cont.)	Cyanide	mg/l	2	4	1.0E-02	1.0E-02	1.0E-02	1.0E-02
	Fluorine	mg/l	5	5	7.0E-02	1.5E-01	3.0E-01	3.4E-01
	Gross Alpha	pCi/l	5	5	2.0E-01	8.4E-01	1.0E+00	1.6E+00
	Gross Beta	pCi/l	5	5	2.0E+00	3.3E+00	4.0E+00	4.9E+00
	Gross Gamma	pCi/l	3	6	4.8E+01	1.4E+02	3.0E+02	4.2E+02
	Hardness	mg/l	5	5	1.0E+01	2.8E+01	3.5E+01	4.8E+01
	Iron	µg/l	5	5	1.1E+02	4.8E+02	1.2E+03	1.4E+03
	Lead	µg/l	1	5	1.0E+00	1.0E+00	1.0E+00	
	Lithium	mg/l	1	1	3.0E-02	3.0E-02	3.0E-02	
	Magnesium	mg/l	5	5	2.4E+00	2.7E+00	3.3E+00	3.4E+00
	Manganese	µg/l	4	5	7.0E+00	2.0E+01	3.5E+01	4.3E+01
	Nitrate, as Nitrogen	mg/l	4	6	4.5E-03	1.4E-01	4.8E-01	6.0E-01
	pH			5	7.4E+00		7.8E+00	
	Phosphate	mg/l	1	1	1.1E-01	1.1E-01	1.1E-01	
	Phosphate, as Phosphorous	mg/l	4	5	3.6E-02	1.2E-01	3.0E-01	3.7E-01
	Plutonium-238	pCi/l	5	8	1.9E-03	8.4E-03	2.0E-02	2.4E-02
	Plutonium-239, Plutonium-240	pCi/l	7	8	8.0E-03	2.4E-02	3.9E-02	4.9E-02
	Potassium	mg/l	5	5	1.8E+00	2.5E+00	3.0E+00	3.6E+00
	Selenium	µg/l	1	5	6.0E+00	6.0E+00	6.0E+00	
	Silica	mg/l	6	6	3.8E+01	5.0E+01	5.6E+01	6.3E+01
	Silver	µg/l	1	5	1.0E+00	1.0E+00	1.0E+00	
	Sodium	mg/l	5	5	5.0E+00	7.1E+00	1.0E+01	1.1E+01
	Strontium	µg/l	5	5	3.8E+01	5.0E+01	7.0E+01	7.8E+01
Sulfate	mg/l	5	5	4.9E+00	5.4E+00	7.0E+00	7.2E+00	

TABLE C-3.—Surface Water Detection Statistics by Watershed and Analyte
(Environmental Surveillance Report Data 1991 to 1996)-Continued

WATERSHED ^a	ANALYTE	UNITS ^b	DETECTED	ANALYZED	MINIMUM	MEAN	MAXIMUM	95% UCL ^c
Guaje (cont.)	Thallium	mg/l	2	3	2.4E+01	2.6E+01	2.8E+01	3.1E+01
	Tin	µg/l	1	3	3.0E+01	3.0E+01	3.0E+01	
	Total Dissolved Solids	mg/l	5	5	8.8E+01	1.4E+02	1.8E+02	2.1E+02
	Tritium	nCi/l	5	6	3.0E-04	3.6E-01	7.0E-01	9.7E-01
	Uranium	µg/l	3	5	7.0E-02	1.8E-01	3.6E-01	5.0E-01
	Vanadium	µg/l	1	5	3.0E+00	3.0E+00	3.0E+00	
	Zinc	µg/l	2	5	8.0E+00	3.5E+01	6.2E+01	1.1E+02
	Acetone	µg/l	1	5	1.5E+01	1.5E+01	1.5E+01	
	Aluminum	µg/l	19	20	1.0E+02	2.6E+03	1.4E+04	9.7E+03
	Americium-241	pCi/l	19	20	1.4E-02	2.3E-01	1.3E+00	9.6E-01
Los Alamos	Antimony	µg/l	2	20	1.2E+00	1.6E+00	2.0E+00	2.7E+00
	Arsenic	µg/l	6	20	3.0E+00	3.9E+00	5.2E+00	5.7E+00
	Barium	µg/l	19	19	1.6E+01	6.6E+01	1.4E+02	1.4E+02
	Benzoic acid	µg/l	1	4	1.1E+01	1.1E+01	1.1E+01	
	Beryllium	µg/l	2	20	1.0E+00	1.0E+00	1.0E+00	1.0E+00
	Bicarbonate	mg/l	17	17	2.4E+01	6.2E+01	1.4E+02	1.4E+02
	Bis(2-ethylhexyl) phthalate	µg/l	2	4	2.0E+00	8.0E+00	1.4E+01	2.5E+01
	Boron	µg/l	13	20	1.0E+01	4.8E+01	1.6E+02	1.2E+02
	Bromine	µg/l	1	4	1.1E+02	1.1E+02	1.1E+02	
	Cadmium	mg/l	17	17	4.0E+00	2.6E+01	1.1E+02	8.1E+01
	Calcium	mg/l	20	20	6.0E+00	1.6E+01	3.6E+01	3.6E+01
	Carbonate	mg/l	2	17	9.0E+00	1.9E+01	2.8E+01	4.6E+01
	Cesium-137	pCi/l	31	42	2.0E-02	1.2E+01	1.6E+02	7.5E+01
	Chromium	µg/l	5	20	4.0E+00	9.8E+00	1.7E+01	1.9E+01

**TABLE C-3.—Surface Water Detection Statistics by Watershed and Analyte
(Environmental Surveillance Report Data 1991 to 1996)-Continued**

WATERSHED ^a	ANALYTE	UNITS ^b	DETECTED	ANALYZED	MINIMUM	MEAN	MAXIMUM	95% UCL ^c
Los Alamos (cont.)	Cobalt	µg/l	4	19	4.0E+00	7.0E+00	1.0E+01	1.3E+01
	Copper	µg/l	5	20	7.0E+00	1.3E+01	2.1E+01	2.4E+01
	Cyanide	mg/l	1	14	1.0E-02	1.0E-02	1.0E-02	
	Di-n-butyl phthalate	µg/l	2	4	4.0E+00	5.5E+00	7.0E+00	9.7E+00
	Di-n-octyl phthalate	µg/l	1	4	8.0E+00	8.0E+00	8.0E+00	
	Fluorine	mg/l	15	17	6.0E-02	4.2E-01	1.1E+00	1.0E+00
	Gross Alpha	pCi/l	28	41	3.0E-01	3.4E+00	3.2E+01	1.8E+01
	Gross Beta	pCi/l	41	41	1.0E+00	2.8E+01	2.1E+02	1.2E+02
	Gross Gamma	pCi/l	25	37	1.0E+01	7.9E+01	4.0E+02	2.5E+02
	Hardness	mg/l	20	20	1.5E+01	5.3E+01	1.5E+02	1.2E+02
	Iron	µg/l	20	20	2.0E+01	1.5E+03	7.9E+03	5.6E+03
	Lead	µg/l	11	22	1.0E+00	1.2E+01	4.5E+01	4.1E+01
	Lithium	mg/l	3	6	6.0E-03	1.3E-02	2.0E-02	2.7E-02
	Magnesium	mg/l	20	20	1.3E+00	2.6E+00	5.2E+00	4.6E+00
	Manganese	µg/l	15	20	4.0E+00	1.3E+02	5.2E+02	4.6E+02
	Mercury	µg/l	5	20	1.0E-01	2.8E-01	1.0E+00	1.1E+00
	Molybdenum	µg/l	6	20	6.0E+00	2.4E+01	5.1E+01	5.7E+01
	Nickel	µg/l	3	20	2.0E+00	1.5E+01	2.2E+01	3.8E+01
	Nitrate, as Nitrogen	mg/l	13	22	7.0E-02	1.1E+00	3.9E+00	3.1E+00
	Nitrite, as Nitrogen	mg/l	1	4	4.6E-01	4.6E-01	4.6E-01	
	pH			17	7.1E+00		9.2E+00	
	Phosphate	mg/l	1	4	1.7E+00	1.7E+00	1.7E+00	

TABLE C-3.—Surface Water Detection Statistics by Watershed and Analyte
(Environmental Surveillance Report Data 1991 to 1996)-Continued

WATERSHED ^a	ANALYTE	UNITS ^b	DETECTED	ANALYZED	MINIMUM	MEAN	MAXIMUM	95% UCL ^c
Los Alamos (cont.)	Phosphate, as Phosphorous	mg/l	11	17	4.0E-02	2.1E-01	8.0E-01	7.0E-01
	Plutonium-238	pCi/l	78	108	1.0E-03	2.8E-02	2.5E-01	1.2E-01
	Plutonium-239, Plutonium-240	pCi/l	104	110	2.0E-03	4.9E-01	1.2E+01	4.2E+00
	Potassium	mg/l	19	20	1.7E+00	4.5E+00	7.2E+00	8.4E+00
	Selenium	µg/l	2	20	1.3E+00	4.2E+00	7.0E+00	1.2E+01
	Silica	mg/l	20	21	1.5E+01	3.3E+01	5.1E+01	5.3E+01
	Silver	µg/l	1	20	1.0E+00	1.0E+00	1.0E+00	
	Sodium	mg/l	20	20	5.0E+00	2.5E+01	8.7E+01	7.1E+01
	Strontium	µg/l	20	20	4.5E+01	9.2E+01	2.3E+02	1.9E+02
	Strontium-90	pCi/l	14	18	1.0E-01	1.4E+01	8.5E+01	6.1E+01
	Sulfate	mg/l	17	17	4.0E+00	7.6E+00	2.2E+01	1.7E+01
	Thallium	µg/l	3	20	4.3E-01	6.1E-01	8.0E-01	9.8E-01
	Total Dissolved Solids	mg/l	17	17	6.6E+01	2.1E+02	5.4E+02	4.8E+02
	Total Suspended Solids	mg/l	32	35	1.8E+00	1.3E+03	1.4E+04	7.6E+03
	Tritium	nCi/l	32	42	2.0E-04	5.7E-01	2.2E+00	1.6E+00
	Uranium	µg/l	23	33	6.0E-02	4.5E-01	2.2E+00	1.4E+00
	Vanadium	µg/l	6	20	4.0E+00	1.2E+01	2.2E+01	2.7E+01
Zinc	µg/l	13	20	6.0E+00	4.6E+01	1.2E+02	1.2E+02	

**TABLE C-3.—Surface Water Detection Statistics by Watershed and Analyte
(Environmental Surveillance Report Data 1991 to 1996)-Continued**

WATERSHED ^a	ANALYTE	UNITS ^b	DETECTED	ANALYZED	MINIMUM	MEAN	MAXIMUM	95% UCL ^c
Mortandad	Aluminum	µg/l	10	11	9.0E+01	2.7E+03	1.4E+04	1.1E+04
	Americium-241	pCi/l	6	8	2.2E-02	1.1E+00	2.2E+00	2.7E+00
	Antimony	µg/l	3	11	6.0E-01	1.6E+00	3.0E+00	4.1E+00
	Arsenic	µg/l	9	11	2.0E+00	3.3E+00	5.0E+00	5.3E+00
	Barium	µg/l	9	9	3.0E+01	5.4E+01	9.3E+01	9.8E+01
	Beryllium	µg/l	2	11	5.0E-01	1.3E+00	2.0E+00	3.4E+00
	Bicarbonate	mg/l	11	11	7.0E+01	1.3E+02	2.1E+02	2.0E+02
	Boron	µg/l	11	11	1.9E+01	2.1E+02	4.1E+02	5.4E+02
	Cadmium	µg/l	1	11	4.0E-01	4.0E-01	4.0E-01	
	Calcium	mg/l	11	11	2.5E+01	4.6E+01	1.9E+02	1.4E+02
	Carbonate	mg/l	2	11	2.0E+00	7.0E+00	1.2E+01	2.1E+01
	Cesium-137	pCi/l	7	8	2.4E-01	2.6E+01	9.0E+01	9.3E+01
	Chlorine	mg/l	11	11	6.0E+00	2.9E+01	7.4E+01	7.7E+01
	Chromium	µg/l	5	11	3.0E+00	4.5E+00	6.3E+00	7.0E+00
	Cobalt	µg/l	2	10	4.0E+00	3.2E+01	6.0E+01	1.1E+02
	Copper	µg/l	10	11	6.0E+00	2.1E+01	4.0E+01	4.1E+01
	Cyanide	mg/l	3	9	1.0E-02	1.5E-02	2.0E-02	2.5E-02
	Fluorine	mg/l	11	11	3.0E-01	7.3E-01	1.1E+00	1.3E+00
	Gross Alpha	pCi/l	7	9	4.4E-01	1.3E+01	4.9E+01	5.0E+01
	Gross Beta	pCi/l	9	9	6.4E+00	8.1E+01	3.5E+02	3.0E+02
Gross Gamma	pCi/l	7	9	2.0E+01	1.2E+02	6.0E+02	5.5E+02	
Hardness	mg/l	11	11	7.3E+01	1.5E+02	6.1E+02	4.6E+02	
Iron	µg/l	11	11	7.0E+01	1.8E+03	1.1E+04	8.1E+03	
Lead	µg/l	6	12	5.0E-01	9.1E+00	4.3E+01	4.2E+01	
Lithium	mg/l	2	2	2.9E-02	3.2E-02	3.4E-02	3.9E-02	
Magnesium	mg/l	11	11	2.2E+00	7.9E+00	3.3E+01	2.5E+01	

TABLE C-3.—Surface Water Detection Statistics by Watershed and Analyte
(Environmental Surveillance Report Data 1991 to 1996)-Continued

WATERSHED ^a	ANALYTE	UNITS ^b	DETECTED	ANALYZED	MINIMUM	MEAN	MAXIMUM	95% UCL ^c
Mortandad (cont.)	Manganese	µg/l	10	11	5.0E+00	3.7E+01	8.3E+01	8.2E+01
	Mercury	µg/l	2	11	3.0E-01	3.5E-01	4.0E-01	4.9E-01
	Molybdenum	µg/l	8	10	1.1E+01	2.8E+02	1.2E+03	1.1E+03
	Nickel	µg/l	2	11	1.0E+01	2.5E+01	4.0E+01	6.7E+01
	Nitrite, as Nitrogen	mg/l	11	11	5.1E-01	6.8E+00	1.8E+01	1.7E+01
	pH		11	11	7.5E+00		8.6E+00	
	Phosphate, as Phosphorous	mg/l	10	10	8.0E-02	3.6E+00	9.0E+00	1.1E+01
	Plutonium-238	pCi/l	9	10	3.9E-03	9.8E-01	4.7E+00	4.2E+00
	Plutonium-239, Plutonium-240	pCi/l	8	10	7.0E-03	4.3E-01	1.5E+00	1.5E+00
	Potassium	mg/l	11	11	3.0E+00	1.3E+01	4.3E+01	3.5E+01
	Selenium	µg/l	4	11	1.0E+00	1.7E+02	6.7E+02	8.4E+02
	Silica	mg/l	11	11	3.9E+01	6.8E+01	9.9E+01	1.1E+02
	Sodium	mg/l	11	11	2.1E+01	7.3E+01	1.8E+02	1.6E+02
	Strontium	µg/l	11	11	6.0E+01	1.0E+02	1.6E+02	1.6E+02
	Strontium-90	pCi/l	8	9	5.0E-01	9.0E+01	5.0E+02	4.3E+02
	Sulfate	mg/l	11	11	5.0E+00	2.1E+01	4.1E+01	4.8E+01
	Thallium	µg/l	2	11	1.7E-01	3.1E+00	6.0E+00	1.1E+01
	Tin	µg/l	2	8	4.5E+01	8.8E+01	1.3E+02	2.1E+02
	Total Dissolved Solids	mg/l	11	11	2.1E+02	4.1E+02	1.1E+03	9.1E+02
	Total Suspended Solids	mg/l	3	4	2.0E+00	1.3E+01	2.4E+01	3.5E+01
	Tritium	nCi/l	9	10	4.0E-04	6.7E+00	1.8E+01	2.1E+01
	Uranium	µg/l	11	11	4.0E-01	1.2E+00	2.7E+00	2.7E+00

TABLE C-3.—Surface Water Detection Statistics by Watershed and Analyte
(Environmental Surveillance Report Data 1991 to 1996)-Continued

WATERSHED ^a	ANALYTE	UNITS ^b	DETECTED	ANALYZED	MINIMUM	MEAN	MAXIMUM	95% UCL ^c
Mortandad (cont.)	Vanadium	µg/l	7	11	9.0E+00	1.0E+01	1.1E+01	1.2E+01
	Zinc	µg/l	9	11	1.0E+01	2.5E+01	3.9E+01	4.2E+01
Pajarito	Acetone	µg/l	1	4	2.4E+01	2.4E+01	2.4E+01	
	Aluminum	µg/l	8	10	1.0E+01	9.5E+02	3.8E+03	3.6E+03
	Americium-241	pCi/l	7	8	8.0E-03	2.5E-02	3.7E-02	4.9E-02
	Antimony	µg/l	2	10	3.0E-01	4.5E-01	6.0E-01	8.7E-01
	Arsenic	µg/l	4	10	2.0E+00	4.0E+00	9.0E+00	1.1E+01
	Barium	µg/l	9	9	3.8E+01	8.9E+01	1.8E+02	2.0E+02
	Beryllium	µg/l	3	10	5.0E-01	2.4E+01	6.8E+01	1.0E+02
	Bicarbonate	mg/l	11	11	5.7E+01	7.8E+01	9.5E+01	1.0E+02
	Boron	µg/l	10	10	2.0E+01	4.9E+01	2.1E+02	1.6E+02
	Cadmium	µg/l	3	10	3.0E-01	5.1E+01	1.5E+02	2.2E+02
	Calcium	mg/l	10	11	1.5E+01	2.2E+01	3.0E+01	3.1E+01
	Cesium-137	pCi/l	11	17	2.1E-01	4.1E+01	3.3E+02	2.4E+02
	Chlorine	mg/l	11	11	5.0E+00	2.4E+01	6.2E+01	6.8E+01
	Chromium	µg/l	7	10	2.2E+00	7.8E+01	5.1E+02	4.6E+02
	Cobalt	µg/l	3	9	1.4E+01	8.3E+01	1.7E+02	2.4E+02
	Copper	µg/l	4	10	4.0E+00	1.4E+02	5.2E+02	6.5E+02
	Di-n-butyl phthalate	µg/l	1	4	2.0E+00	2.0E+00	2.0E+00	
Fluorine	mg/l	10	11	1.0E-01	3.4E-01	5.0E-01	6.6E-01	
Gross Alpha	pCi/l	13	15	5.0E-02	1.1E+00	3.0E+00	2.6E+00	
Gross Beta	pCi/l	15	15	1.0E+00	4.6E+00	9.0E+00	9.2E+00	
Gross Gamma	pCi/l	10	14	1.0E+01	1.6E+02	9.0E+02	7.0E+02	
Hardness	mg/l	11	11	5.6E+01	7.7E+01	1.1E+02	1.1E+02	
Iron	µg/l	9	10	2.0E+01	2.7E+03	1.8E+04	1.4E+04	

TABLE C-3.—Surface Water Detection Statistics by Watershed and Analyte
(Environmental Surveillance Report Data 1991 to 1996)-Continued

WATERSHED ^a	ANALYTE	UNITS ^b	DETECTED	ANALYZED	MINIMUM	MEAN	MAXIMUM	95% UCL ^c
Pajarito (cont.)	Lead	µg/l	3	10	5.0E-01	1.5E+00	2.0E+00	3.1E+00
	Lithium	mg/l	2	2	4.0E-03	1.6E-02	2.7E-02	4.8E-02
	Magnesium	mg/l	10	11	4.3E+00	5.5E+00	7.3E+00	7.8E+00
	Manganese	µg/l	9	10	2.0E+00	3.1E+02	2.1E+03	1.7E+03
	Mercury	µg/l	1	10	2.0E-01	2.0E-01	2.0E-01	
	Molybdenum	µg/l	5	10	1.0E+00	9.9E+01	3.4E+02	4.0E+02
	Nickel	µg/l	1	10	2.4E+02	2.4E+02	2.4E+02	
	Nitrate, as Nitrogen	mg/l	10	11	4.0E-02	6.4E-01	1.5E+00	1.5E+00
	pH		11	11	6.8E+00		8.5E+00	
	Phosphate, as Phosphorous	mg/l	5	11	2.0E-02	1.5E-01	3.0E-01	3.9E-01
	Plutonium-238	pCi/l	18	31	1.0E-03	9.4E-03	2.2E-02	2.3E-02
	Plutonium-239 Plutonium-240	pCi/l	20	31	1.0E-03	1.2E-02	4.5E-02	3.3E-02
	Potassium	mg/l	10	11	1.5E+00	3.3E+00	5.0E+00	5.5E+00
	Selenium	µg/l	1	10	3.0E+00	3.0E+00	3.0E+00	
	Silica	mg/l	11	11	2.9E+01	5.3E+01	7.3E+01	9.0E+01
	Silver	µg/l	3	10	1.0E+00	3.4E+01	9.6E+01	1.4E+02
	Sodium	mg/l	10	11	1.2E+01	1.9E+01	3.1E+01	3.4E+01
	Strontium	µg/l	10	10	1.1E+02	1.8E+02	5.1E+02	4.1E+02
	Strontium-90	pCi/l	7	9	3.0E-01	1.5E+01	1.0E+02	9.0E+01
	Sulfate	mg/l	11	11	4.0E+00	1.1E+01	3.2E+01	2.7E+01
	Thallium	µg/l	1	10	2.0E-01	2.0E-01	2.0E-01	
	Tin	µg/l	3	9	1.0E+01	3.0E+01	6.3E+01	8.8E+01
	Total Dissolved Solids	mg/l	11	11	1.4E+02	2.4E+02	7.5E+02	5.8E+02

TABLE C-3.—Surface Water Detection Statistics by Watershed and Analyte
(Environmental Surveillance Report Data 1991 to 1996)-Continued

WATERSHED ^a	ANALYTE	UNITS ^b	DETECTED	ANALYZED	MINIMUM	MEAN	MAXIMUM	95% UCL ^c
Pajarito (cont.)	Total Suspended Solids	mg/l	6	8	2.0E+00	1.6E+01	4.1E+01	5.5E+01
	Tritium	nCi/l	11	17	1.0E-04	3.7E-01	6.0E-01	7.9E-01
	Uranium	µg/l	11	14	1.0E-01	6.7E-01	1.2E+00	1.6E+00
	Vanadium	µg/l	7	10	1.0E+00	2.8E+01	1.0E+02	9.6E+01
	Zinc	µg/l	6	10	5.0E+00	8.0E+01	2.5E+02	2.6E+02
	Acetone	µg/l	1	5	3.2E+01	3.2E+01	3.2E+01	
	Aluminum	µg/l	13	16	1.6E+02	1.2E+03	3.2E+03	3.2E+03
	Americium-241	pCi/l	10	13	6.0E-04	7.2E-02	1.7E-01	1.9E-01
	Antimony	µg/l	4	15	2.0E-01	2.8E-01	4.0E-01	4.7E-01
	Arsenic	µg/l	15	16	2.0E+00	5.6E+00	1.3E+01	1.3E+01
Pueblo	Barium	µg/l	13	13	6.8E+00	4.2E+02	5.2E+03	3.3E+03
	Beryllium	µg/l	5	16	1.0E+00	2.4E+02	1.2E+03	1.3E+03
	Bicarbonate	mg/l	15	16	3.5E+01	9.0E+01	2.3E+02	1.9E+02
	Bis(2-ethylhexyl) phthalate	µg/l	1	2	8.0E+00	8.0E+00	8.0E+00	
	Boron	µg/l	14	16	2.5E+01	4.3E+02	4.2E+03	2.6E+03
	Cadmium	µg/l	5	16	3.0E-01	2.0E+02	1.0E+03	1.1E+03
	Calcium	mg/l	16	16	9.7E+00	1.7E+01	3.1E+01	2.9E+01
	Cesium-137	pCi/l	23	24	4.9E-01	2.9E+01	3.2E+02	1.8E+02
	Chlorine	mg/l	16	16	2.8E+01	6.0E+01	2.1E+02	1.6E+02
	Chromium	µg/l	12	16	3.2E+00	4.3E+02	5.0E+03	3.3E+03
	Cobalt	µg/l	4	16	5.0E+00	2.2E+02	8.5E+02	1.1E+03
	Copper	µg/l	12	16	2.0E+00	4.6E+02	5.3E+03	3.5E+03
	Cyanide	mg/l	2	8	2.0E-02	3.0E-02	4.0E-02	5.8E-02
	Fluorine	mg/l	16	16	2.0E-01	4.4E-01	9.0E-01	8.3E-01

TABLE C-3.—Surface Water Detection Statistics by Watershed and Analyte
(Environmental Surveillance Report Data 1991 to 1996)-Continued

WATERSHED ^a	ANALYTE	UNITS ^b	DETECTED	ANALYZED	MINIMUM	MEAN	MAXIMUM	95% UCL ^c
Pueblo (cont.)	Gross Alpha	pCi/l	13	21	2.0E-01	1.4E+00	3.0E+00	3.1E+00
	Gross Beta	pCi/l	21	21	2.0E+00	2.1E+01	1.4E+02	7.8E+01
	Gross Gamma	pCi/l	19	24	1.0E+01	1.4E+02	5.0E+02	4.5E+02
	Hardness	mg/l	16	16	3.0E+01	5.5E+01	9.9E+01	1.0E+02
	Iron	µg/l	15	16	2.0E+02	7.9E+02	1.9E+03	1.9E+03
	Lead	µg/l	12	15	1.0E+00	2.6E+00	5.6E+00	5.8E+00
	Lithium	mg/l	2	2	1.0E-02	1.1E-02	1.1E-02	1.2E-02
	Magnesium	mg/l	16	16	1.2E+00	3.1E+00	6.4E+00	6.0E+00
	Manganese	µg/l	16	16	2.0E+00	3.8E+02	5.4E+03	3.1E+03
	Mercury	µg/l	5	16	1.0E-01	2.8E-01	4.0E-01	6.1E-01
	Molybdenum	µg/l	8	16	2.0E+00	1.3E+02	1.0E+03	8.3E+02
	Nickel	µg/l	3	16	3.0E+01	1.9E+03	5.5E+03	8.2E+03
	Nitrate, as Nitrogen	mg/l	13	16	2.5E-01	4.7E+00	1.7E+01	1.6E+01
	pH		16	16	1.7E+00		8.7E+00	
	Phosphate, as Phosphorous	mg/l	12	12	3.0E-01	2.1E+00	8.9E+00	7.6E+00
	Plutonium-238	pCi/l	28	57	1.0E-03	5.1E-02	4.6E-01	2.4E-01
	Plutonium-239, Plutonium-240	pCi/l	49	57	4.0E-03	2.1E+00	5.2E+01	1.9E+01
	Potassium	mg/l	13	13	4.0E+00	9.6E+00	1.5E+01	1.9E+01
	Selenium	µg/l	1	16	1.8E+01	1.8E+01	1.8E+01	
	Silica	mg/l	16	16	1.7E+01	5.0E+01	9.1E+01	1.1E+02
Silver	µg/l	9	16	4.0E-01	1.3E+02	6.9E+02	6.1E+02	
Sodium	mg/l	16	16	3.6E+01	5.9E+01	8.1E+01	8.7E+01	
Strontium	µg/l	16	16	5.1E+01	4.1E+02	5.3E+03	3.0E+03	
Strontium-90	pCi/l	9	11	5.0E-01	3.3E+00	8.3E+00	9.2E+00	

**TABLE C-3.—Surface Water Detection Statistics by Watershed and Analyte
(Environmental Surveillance Report Data 1991 to 1996)-Continued**

WATERSHED ^a	ANALYTE	UNITS ^b	DETECTED	ANALYZED	MINIMUM	MEAN	MAXIMUM	95% UCL ^c
Pueblo (cont.)	Sulfate	mg/l	16	16	6.0E+00	1.8E+01	3.8E+01	3.8E+01
	Thallium	µg/l	3	16	1.0E-01	2.0E-01	3.0E-01	4.0E-01
	Tin	µg/l	1	12	9.2E+02	9.2E+02	9.2E+02	
	Total Dissolved Solids	mg/l	16	16	1.9E+02	3.4E+02	4.7E+02	5.2E+02
	Total Suspended Solids	mg/l	15	16	2.0E+00	1.9E+03	1.5E+04	9.5E+03
	Tritium	nCi/l	19	24	4.0E-04	3.7E-01	1.5E+00	1.0E+00
	Uranium	µg/l	12	20	6.0E-02	3.9E-01	8.0E-01	9.3E-01
	Vanadium	µg/l	10	16	4.0E+00	1.2E+02	1.0E+03	7.4E+02
	Zinc	µg/l	13	16	4.0E+00	1.7E+02	1.3E+03	8.9E+02
	Aluminum	µg/l	17	18	1.0E+02	6.9E+02	3.3E+03	2.3E+03
Sandia	Americium-241	pCi/l	11	13	2.0E-03	3.6E-02	6.6E-02	8.2E-02
	Antimony	µg/l	6	18	3.0E-01	7.3E-01	1.7E+00	1.7E+00
	Arsenic	µg/l	13	15	4.0E+00	5.5E+00	9.0E+00	8.1E+00
	Barium	µg/l	15	15	2.4E+01	8.3E+01	7.7E+02	4.6E+02
	Beryllium	µg/l	3	18	5.0E-01	4.1E+01	1.2E+02	1.8E+02
	Bicarbonate	mg/l	18	18	8.8E+01	1.2E+02	1.5E+02	1.6E+02
	Boron	µg/l	18	18	4.2E+01	8.7E+01	4.0E+02	2.5E+02
	Cadmium	µg/l	5	15	6.0E-01	3.3E+01	1.5E+02	1.6E+02
	Calcium	mg/l	18	18	1.5E+01	2.5E+01	4.0E+01	3.8E+01
	Carbonate	mg/l	6	18	2.0E+00	7.3E+00	1.5E+01	1.9E+01
	Cesium-137	pCi/l	9	20	5.2E-01	4.1E+01	2.7E+02	2.2E+02
	Chlorine	mg/l	18	18	2.7E+01	5.5E+01	1.1E+02	9.4E+01
	Chromium	µg/l	15	18	1.1E+01	6.6E+01	7.6E+02	4.5E+02
	Cobalt	µg/l	2	15	2.6E+01	9.3E+01	1.6E+02	2.8E+02
	Copper	µg/l	15	18	5.0E+00	6.1E+01	7.5E+02	4.4E+02

TABLE C-3.—Surface Water Detection Statistics by Watershed and Analyte
(Environmental Surveillance Report Data 1991 to 1996)-Continued

WATERSHED ^a	ANALYTE	UNITS ^b	DETECTED	ANALYZED	MINIMUM	MEAN	MAXIMUM	95% UCL ^c
Sandia (cont.)	Cyanide	mg/l	8	15	1.0E-02	2.9E-02	1.1E-01	9.5E-02
	Di-n-butyl phthalate	µg/l	1	2	2.0E+00	2.0E+00	2.0E+00	
	Fluorine	mg/l	18	18	4.0E-01	1.2E+00	2.5E+00	2.5E+00
	Gross Alpha	pCi/l	8	18	1.0E+00	2.8E+01	2.1E+02	1.8E+02
	Gross Beta	pCi/l	18	18	1.0E+00	1.2E+01	3.1E+01	2.6E+01
	Gross Gamma	pCi/l	8	19	2.0E+01	1.9E+02	4.8E+02	5.7E+02
	Hardness	mg/l	18	18	5.5E+01	8.4E+01	1.4E+02	1.3E+02
	Iron	µg/l	18	18	9.0E+01	6.5E+02	2.6E+03	1.8E+03
	Lead	µg/l	13	21	2.0E+00	4.7E+00	1.9E+01	1.5E+01
	Lithium	mg/l	3	3	4.3E-02	4.9E-02	5.9E-02	6.7E-02
	Magnesium	mg/l	18	18	4.0E+00	5.0E+00	7.3E+00	6.5E+00
	Manganese	µg/l	17	18	7.0E+00	1.1E+02	8.0E+02	5.8E+02
	Mercury	µg/l	5	17	1.0E-01	1.4E-01	3.0E-01	3.2E-01
	Molybdenum	µg/l	18	18	6.0E+01	3.7E+02	1.2E+03	1.0E+03
	Nickel	µg/l	4	18	1.0E+01	3.7E+02	7.9E+02	1.2E+03
	Nitrate, as Nitrogen	mg/l	18	18	4.0E-02	4.1E+00	2.0E+01	1.5E+01
	pH		18	18	7.7E+00		8.9E+00	
	Phosphate, as Phosphorous	mg/l	18	18	2.6E-01	3.1E+00	1.6E+01	9.8E+00
	Plutonium-238	pCi/l	11	21	2.0E-03	7.6E-03	2.1E-02	2.0E-02
	Plutonium-239, Plutonium-240	pCi/l	18	21	1.0E-03	1.1E-02	4.4E-02	3.4E-02
	Potassium	mg/l	15	15	3.0E+00	1.1E+01	1.4E+01	1.6E+01
Selenium	µg/l	4	18	2.0E+00	2.5E+00	3.1E+00	3.7E+00	
Silica	mg/l	21	21	2.4E+01	8.4E+01	1.0E+02	1.2E+02	

**TABLE C-3.—Surface Water Detection Statistics by Watershed and Analyte
(Environmental Surveillance Report Data 1991 to 1996)-Continued**

WATERSHED ^a	ANALYTE	UNITS ^b	DETECTED	ANALYZED	MINIMUM	MEAN	MAXIMUM	95% UCL ^c
Sandia (cont.)	Silver	µg/l	11	18	5.0E-01	1.9E+01	6.7E+01	7.9E+01
	Sodium	mg/l	18	18	4.8E+01	8.4E+01	1.1E+02	1.2E+02
	Strontium	µg/l	18	18	7.1E+01	1.8E+02	9.1E+02	6.5E+02
	Strontium-90	pCi/l	11	13	6.0E-02	4.4E-01	1.1E+00	1.2E+00
	Sulfate	mg/l	18	18	1.3E+01	6.8E+01	1.1E+02	1.3E+02
	Thallium	µg/l	3	18	2.0E-01	2.0E-01	2.0E-01	2.0E-01
	Tin	µg/l	6	18	2.0E+01	7.6E+01	2.4E+02	2.6E+02
	Total Dissolved Solids	mg/l	18	18	2.2E+02	4.7E+02	7.6E+02	7.2E+02
	Total Suspended Solids	mg/l	6	6	4.0E+00	9.8E+00	2.2E+01	2.4E+01
	Tritium	nCi/l	15	21	2.0E-04	3.9E-01	1.1E+00	1.1E+00
	Uranium	µg/l	15	19	3.0E-01	8.7E-01	4.7E+00	3.1E+00
	Vanadium	µg/l	18	18	8.1E+00	2.7E+01	9.0E+01	7.7E+01
	Zinc	µg/l	18	18	1.0E+01	7.4E+01	2.1E+02	1.8E+02
	Acetone	µg/l	1	2	4.9E+01	4.9E+01	4.9E+01	
Water	Aluminum	µg/l	3	3	6.0E+02	5.0E+03	1.2E+04	1.7E+04
	Americium-241	pCi/l	1	2	1.3E-02	1.3E-02	1.3E-02	
	Antimony	µg/l	1	3	3.0E-01	3.0E-01	3.0E-01	
	Arsenic	µg/l	2	3	2.0E+00	3.0E+00	4.0E+00	5.8E+00
	Barium	µg/l	2	2	4.0E+02	4.6E+02	5.2E+02	6.3E+02
	Beryllium	µg/l	1	3	1.0E+00	1.0E+00	1.0E+00	
	Bicarbonate	mg/l	3	3	4.8E+01	5.8E+01	6.6E+01	7.7E+01
	Boron	µg/l	3	3	3.0E+01	5.6E+01	9.0E+01	1.2E+02
	Cadmium	µg/l	2	3	2.1E+00	2.6E+00	3.0E+00	3.8E+00
	Calcium	mg/l	3	3	1.2E+01	1.4E+01	1.6E+01	1.9E+01
	Cesium-137	pCi/l	4	5	7.1E-01	5.7E+01	1.7E+02	2.2E+02

TABLE C-3.—Surface Water Detection Statistics by Watershed and Analyte
(Environmental Surveillance Report Data 1991 to 1996)-Continued

WATERSHED ^a	ANALYTE	UNITS ^b	DETECTED	ANALYZED	MINIMUM	MEAN	MAXIMUM	95% UCL ^c
Water (cont.)	Chlorine	mg/l	3	3	9.0E+00	1.8E+01	2.9E+01	3.8E+01
	Fluorine	mg/l	2	3	1.7E-01	1.7E-01	1.7E-01	1.7E-01
	Gross Alpha	pCi/l	3	4	1.0E+00	2.8E+00	5.5E+00	7.6E+00
	Gross Beta	pCi/l	4	4	4.0E+00	6.9E+00	9.0E+00	1.1E+01
	Gross Gamma	pCi/l	3	5	2.4E+01	9.5E+01	1.9E+02	2.6E+02
	Hardness	mg/l	3	3	4.8E+01	5.5E+01	5.9E+01	6.7E+01
	HMX (Octogen)	µg/l	1	1	4.9E+00	4.9E+00	4.9E+00	
	Iron	µg/l	3	3	4.0E+02	2.4E+03	5.6E+03	8.1E+03
	Lead	µg/l	3	3	2.0E+00	2.3E+00	3.0E+00	3.5E+00
	Lithium	mg/l	1	1	5.0E-03	5.0E-03	5.0E-03	
	Magnesium	mg/l	3	3	4.5E+00	4.8E+00	5.0E+00	5.3E+00
	Manganese	µg/l	3	3	1.4E+01	2.3E+01	2.9E+01	4.0E+01
	Nickel	µg/l	1	3	1.0E+01	1.0E+01	1.0E+01	
	Nitrate, as Nitrogen	mg/l	3	3	3.0E-02	4.1E+00	9.6E+00	1.4E+01
	pH		3	3	6.8E+00		7.5E+00	
	Phosphate, as Phosphorous	mg/l	3	3	6.0E-02	1.6E-01	2.2E-01	3.3E-01
	Plutonium-238	pCi/l	7	9	2.4E-03	1.5E-02	2.3E-02	3.0E-02
	Plutonium-239, Plutonium-240	pCi/l	4	9	1.0E-03	4.3E-03	7.3E-03	9.5E-03
	Potassium	mg/l	3	3	3.9E+00	4.4E+00	5.2E+00	5.8E+00
	RDX (Cyclonite)	µg/l	1	1	7.6E-01	7.6E-01	7.6E-01	
	Selenium	µg/l	1	3	4.8E+01	4.8E+01	4.8E+01	
	Silica	mg/l	3	3	3.0E+01	3.4E+01	3.8E+01	4.2E+01
	Sodium	mg/l	3	3	1.7E+01	1.8E+01	1.9E+01	2.1E+01
Strontium	µg/l	3	3	8.8E+01	9.9E+01	1.2E+02	1.4E+02	

**TABLE C-3.—Surface Water Detection Statistics by Watershed and Analyte
(Environmental Surveillance Report Data 1991 to 1996)-Continued**

WATERSHED ^a	ANALYTE	UNITS ^b	DETECTED	ANALYZED	MINIMUM	MEAN	MAXIMUM	95% UCL ^c
Water (cont.)	Strontium-90	pCi/l	1	2	1.1E+00	1.1E+00	1.1E+00	
	Sulfate	mg/l	3	3	6.0E+00	6.6E+00	7.0E+00	7.8E+00
	Tin	µg/l	2	3	2.6E+01	2.8E+01	3.0E+01	3.4E+01
	Total Dissolved Solids	mg/l	3	3	1.7E+02	1.8E+02	1.9E+02	2.0E+02
	Total Suspended Solids	mg/l	3	3	3.0E+00	1.4E+01	3.6E+01	5.2E+01
	Tritium	nCi/l	4	5	3.0E-04	3.4E-01	8.0E-01	1.0E+00
	Uranium	µg/l	4	4	1.0E-01	4.0E-01	6.2E-01	8.9E-01
	Vanadium	µg/l	1	3	8.0E+00	8.0E+00	8.0E+00	
	Zinc	µg/l	1	2	2.0E+01	2.0E+01	2.0E+01	

^a Watershed includes both on-site and perimeter analyses as designated by the Environmental Surveillance Program.

^b pCi/l is picocuries of radioactive analyte per liter of sample, nCi/l is nanocuries of radioactive analyte per liter of sample, µg/l is micrograms of analyte per liter of sample, mg/l is milligrams of analyte per liter of sample.

^c Upper confidence limit (UCL) not calculated when the number of detected analyses equals 1.

TABLE C-4.—Sediment Detection Statistics by Location and Analyte
(Environmental Surveillance Report Data 1991 to 1996)

LOCATION ^a	ANALYTE	UNITS ^b	DETECTED	ANALYZED	MINIMUM	MEAN	MAXIMUM	95% UCL ^c
On Site	Aluminum	mg/kg	210	210	6.1E+02	5.5E+03	3.2E+04	1.5E+04
	Americium-241	pCi/g	207	224	1.0E-03	4.6E-01	1.2E+01	3.8E+00
	Antimony	mg/kg	6	211	2.5E-01	3.6E+00	8.0E+00	9.8E+00
	Arsenic	mg/kg	204	214	2.8E-01	1.4E+00	5.5E+00	3.4E+00
	Barium	mg/kg	213	213	6.2E+00	8.0E+01	5.5E+02	2.9E+02
	Beryllium	mg/kg	164	211	2.0E-02	5.8E-01	2.9E+00	1.7E+00
	Bis(2-ethylhexyl) phthalate	µg/kg	2	30	3.5E+02	3.5E+02	3.5E+02	3.5E+02
	Boron	mg/kg	95	210	1.1E+00	8.9E+00	1.2E+02	3.9E+01
	Cadmium	mg/kg	33	214	1.8E-01	6.0E-01	2.3E+00	1.5E+00
	Calcium	mg/kg	21	21	1.8E+02	1.2E+03	4.6E+03	3.9E+03
	Cesium-137	pCi/g	252	294	1.0E-02	1.9E+00	1.1E+02	1.8E+01
	Chromium	mg/kg	210	214	1.1E+00	1.2E+01	1.2E+03	1.8E+02
	Cobalt	mg/kg	201	210	5.2E-01	3.5E+00	1.2E+01	8.4E+00
	Copper	mg/kg	159	211	6.7E-01	4.5E+00	3.3E+01	1.2E+01
	Di-n-butyl phthalate	µg/kg	21	30	3.8E+02	6.0E+02	1.0E+03	9.9E+02
	Gross Alpha	pCi/g	292	292	8.0E-01	5.6E+00	5.4E+01	1.9E+01
	Gross Beta	pCi/g	290	292	5.0E-01	4.8E+00	8.9E+01	1.9E+01
	Gross Gamma	pCi/g	262	296	1.0E+00	5.3E+00	1.1E+02	2.2E+01
	Iron	mg/kg	211	211	2.4E+01	6.2E+03	2.7E+04	1.5E+04
	Lead	mg/kg	167	213	1.0E+00	1.3E+01	1.4E+02	3.8E+01
Lithium	mg/kg	21	21	1.2E+00	8.0E+00	5.1E+01	2.9E+01	
Magnesium	mg/kg	21	21	1.2E+02	7.2E+02	2.5E+03	2.2E+03	
Manganese	mg/kg	211	211	4.7E+01	2.4E+02	6.6E+02	5.0E+02	
Mercury	mg/kg	50	196	1.0E-02	2.9E-02	2.0E-01	8.7E-02	

**TABLE C-4.—Sediment Detection Statistics by Location and Analyte
(Environmental Surveillance Report Data 1991 to 1996)-Continued**

LOCATION ^a	ANALYTE	UNITS ^b	DETECTED	ANALYZED	MINIMUM	MEAN	MAXIMUM	95% UCL ^c
On Site (cont.)	Molybdenum	mg/kg	41	211	3.0E-01	1.9E+00	1.4E+01	6.4E+00
	Nickel	mg/kg	116	210	1.1E+00	6.3E+00	1.6E+01	1.3E+01
	Plutonium-238	pCi/g	265	295	2.0E-04	1.8E-01	6.8E+00	1.7E+00
	Plutonium-239, Plutonium-240	pCi/g	294	295	1.0E-03	4.4E-01	1.7E+01	3.7E+00
	Potassium	mg/kg	20	21	1.3E+02	7.2E+02	2.7E+03	2.3E+03
	Selenium	mg/kg	72	214	1.2E-01	3.7E-01	7.0E-01	6.0E-01
	Silver	mg/kg	16	214	3.5E-01	3.5E+00	1.3E+01	1.0E+01
	Sodium	mg/kg	21	21	3.1E+01	1.3E+02	3.1E+02	3.1E+02
	Strontium	mg/kg	210	210	1.6E+00	2.3E+01	1.0E+03	1.8E+02
	Strontium-90	pCi/g	216	251	1.0E-01	4.2E-01	5.0E+00	1.6E+00
	Thallium	mg/kg	20	211	4.0E-02	1.8E+00	1.8E+01	1.0E+01
	Tin	mg/kg	45	210	2.4E+00	2.2E+01	8.6E+01	7.3E+01
	Tritium	nCi/l ^d	172	244	1.3E-02	3.6E+00	9.4E+01	2.8E+01
	Uranium	mg/kg	283	283	4.0E-01	2.0E+00	4.8E+00	3.8E+00
	Vanadium	mg/kg	208	210	1.5E+00	1.2E+01	1.1E+02	3.9E+01
	Zinc	mg/kg	211	211	6.0E+00	4.4E+01	6.5E+02	1.6E+02
	Aluminum	mg/kg	123	123	3.8E+02	4.8E+03	1.9E+04	1.2E+04
	Americium-241	pCi/g	115	124	1.0E-03	3.4E-02	5.3E-01	2.2E-01
	Antimony	mg/kg	4	122	3.0E-02	2.2E-01	7.8E-01	9.7E-01
	Arsenic	mg/kg	111	128	2.1E-01	2.1E+00	6.5E+01	1.5E+01
Barium	mg/kg	128	128	4.9E+00	6.6E+01	6.0E+02	2.4E+02	
Beryllium	mg/kg	101	123	8.0E-02	4.9E-01	1.8E+00	1.1E+00	
Boron	mg/kg	56	123	5.0E-01	4.5E+00	3.3E+01	1.6E+01	
Cadmium	mg/kg	24	128	2.2E-01	7.6E-01	1.8E+00	1.6E+00	
Calcium	mg/kg	8	8	3.1E+02	4.8E+03	1.3E+04	1.5E+04	
Cesium-137	pCi/g	111	149	2.0E-02	2.8E-01	2.1E+00	9.9E-01	
Perimeter								

TABLE C-4.—Sediment Detection Statistics by Location and Analyte
(Environmental Surveillance Report Data 1991 to 1996)-Continued

LOCATION ^a	ANALYTE	UNITS ^b	DETECTED	ANALYZED	MINIMUM	MEAN	MAXIMUM	95% UCL ^c
Perimeter (cont.)	Chromium	mg/kg	127	127	5.8E-01	4.7E+00	1.5E+01	1.0E+01
	Cobalt	mg/kg	119	123	6.0E-01	3.3E+00	1.8E+01	8.0E+00
	Copper	mg/kg	110	123	5.0E-01	4.5E+00	4.4E+01	1.6E+01
	Cyanide	mg/kg	2	5	7.5E-02	1.5E-01	2.3E-01	3.7E-01
	Gross Alpha	pCi/g	146	146	4.1E-01	3.7E+00	1.4E+01	8.6E+00
	Gross Beta	pCi/g	145	145	3.0E-01	2.9E+00	2.8E+01	8.5E+00
	Gross Gamma	pCi/g	138	149	1.0E+00	4.5E+00	1.5E+01	1.1E+01
	Iron	mg/kg	123	123	5.3E+02	6.8E+03	2.2E+04	1.5E+04
	Lead	mg/kg	109	128	1.0E+00	9.9E+00	3.3E+01	2.3E+01
	Lithium	mg/kg	13	13	2.9E+00	1.1E+01	3.1E+01	2.7E+01
	Magnesium	mg/kg	13	13	2.4E+02	1.3E+03	4.1E+03	3.7E+03
	Manganese	mg/kg	123	123	3.7E+01	2.4E+02	6.4E+02	5.0E+02
	Mercury	mg/kg	32	122	1.0E-02	3.0E-02	1.2E-01	6.7E-02
	Molybdenum	mg/kg	21	123	4.0E-01	1.3E+00	2.5E+00	2.5E+00
	Nickel	mg/kg	82	123	1.5E+00	5.2E+00	1.5E+01	1.1E+01
	Plutonium-238	pCi/g	134	150	3.0E-04	6.7E-03	6.1E-02	2.7E-02
	Plutonium-239, Plutonium-240	pCi/g	149	150	1.0E-03	4.0E-01	1.2E+01	3.7E+00
	Potassium	mg/kg	13	13	2.3E+02	9.7E+02	2.6E+03	2.5E+03
	Selenium	mg/kg	39	127	1.0E-01	2.2E+00	6.8E+01	2.4E+01
	Silver	mg/kg	13	128	1.2E+00	6.6E+00	2.7E+01	2.1E+01
	Sodium	mg/kg	8	8	7.3E+01	1.7E+02	3.6E+02	3.9E+02
	Strontium	mg/kg	121	122	1.4E+00	1.2E+01	9.7E+01	3.7E+01
	Strontium-90	pCi/g	110	140	1.0E-01	2.8E-01	2.9E+00	9.3E-01
Thallium	mg/kg	23	122	5.0E-02	8.8E-01	6.4E+00	4.3E+00	
Tin	mg/kg	43	122	3.4E+00	1.1E+01	3.5E+01	2.3E+01	
Tritium	nCi/l ^d	95	131	4.7E-02	6.8E-01	3.6E+00	1.9E+00	

**TABLE C-4.—Sediment Detection Statistics by Location and Analyte
(Environmental Surveillance Report Data 1991 to 1996)-Continued**

LOCATION ^a	ANALYTE	UNITS ^b	DETECTED	ANALYZED	MINIMUM	MEAN	MAXIMUM	95% UCL ^c
Perimeter (cont.)	Uranium	mg/kg	132	132	3.2E-01	2.1E+00	5.9E+00	4.2E+00
	Vanadium	mg/kg	121	122	2.0E+00	1.0E+01	4.3E+01	2.4E+01
	Zinc	mg/kg	122	122	5.5E+00	3.8E+01	3.3E+02	1.1E+02
Regional	Acetone	µg/kg	1	1	2.6E+01	2.6E+01	2.6E+01	
	Aluminum	mg/kg	45	46	6.8E+02	4.9E+03	1.3E+04	1.1E+04
	Americium-241	pCi/g	43	44	1.0E-03	1.6E-02	1.6E-01	9.3E-02
	Arsenic	mg/kg	49	52	4.1E-01	2.2E+00	5.3E+00	4.5E+00
	Barium	mg/kg	51	52	1.1E+01	1.8E+02	6.4E+02	5.3E+02
	Beryllium	mg/kg	35	46	1.0E-01	4.4E-01	7.7E-01	8.1E-01
	Boron	mg/kg	22	46	1.0E+00	1.0E+01	1.0E+02	5.4E+01
	Butyl benzyl phthalate	µg/kg	1	3	1.7E+03	1.7E+03	1.7E+03	
	Cadmium	mg/kg	16	52	2.9E-01	8.4E-01	1.7E+00	1.7E+00
	Calcium	mg/kg	8	9	1.6E+03	6.8E+03	1.6E+04	1.8E+04
	Cesium-137	pCi/g	51	63	1.0E-02	2.5E-01	7.7E+00	2.4E+00
	Chromium	mg/kg	51	52	5.5E-01	7.1E+00	2.6E+01	1.6E+01
	Cobalt	mg/kg	44	46	6.2E-01	4.2E+00	1.3E+01	8.9E+00
	Copper	mg/kg	37	46	1.2E+00	5.1E+00	1.2E+01	1.0E+01
	Gross Alpha	pCi/g	61	61	8.0E-01	3.6E+00	1.5E+01	8.6E+00
	Gross Beta	pCi/g	61	61	3.0E-01	2.7E+00	6.0E+00	5.0E+00
Gross Gamma	pCi/g	55	63	1.3E+00	3.2E+00	1.1E+01	7.0E+00	
Iron	mg/kg	44	46	3.8E+02	7.2E+03	1.9E+04	1.6E+04	
Lead	mg/kg	29	52	1.0E-01	6.4E+00	3.2E+01	1.8E+01	
Lithium	mg/kg	4	4	1.2E+00	4.4E+00	1.1E+01	1.3E+01	
Magnesium	mg/kg	4	4	3.3E+02	9.4E+02	2.5E+03	3.0E+03	
Manganese	mg/kg	46	46	2.6E-01	1.8E+02	3.9E+02	3.7E+02	
Mercury	mg/kg	20	52	2.0E-02	3.2E-02	9.7E-02	6.8E-02	

TABLE C-4.—Sediment Detection Statistics by Location and Analyte
(Environmental Surveillance Report Data 1991 to 1996)-Continued

LOCATION ^a	ANALYTE	UNITS ^b	DETECTED	ANALYZED	MINIMUM	MEAN	MAXIMUM	95% UCL ^c
Regional (cont.)	Molybdenum	mg/kg	6	46	1.3E+00	2.4E+00	3.9E+00	4.5E+00
	Nickel	mg/kg	31	46	2.0E+00	7.4E+00	2.2E+01	1.5E+01
	Plutonium-238	pCi/g	53	59	2.0E-04	3.8E-03	1.3E-02	1.0E-02
	Plutonium-239, Plutonium-240	pCi/g	59	59	1.0E-03	4.2E-03	2.4E-02	1.1E-02
	Potassium	mg/kg	4	4	1.3E+02	4.0E+02	1.1E+03	1.3E+03
	Selenium	mg/kg	18	52	1.0E-01	5.3E-01	2.7E+00	1.9E+00
	Silver	mg/kg	6	52	1.0E+00	3.0E+00	5.0E+00	5.5E+00
	Sodium	mg/kg	4	4	3.8E+01	8.5E+01	1.8E+02	2.1E+02
	Strontium	mg/kg	45	46	3.4E+00	5.1E+01	2.2E+02	1.3E+02
	Strontium-90	pCi/g	37	55	1.0E-01	6.4E-01	1.1E+01	4.2E+00
	Thallium	mg/kg	6	46	5.0E-02	7.8E-02	1.0E-01	1.1E-01
	Tin	mg/kg	12	46	8.0E+00	1.3E+01	2.1E+01	2.1E+01
	Tritium	nCi/l ^d	30	58	2.1E-02	2.1E-01	6.0E-01	4.5E-01
	Uranium	mg/kg	61	61	6.1E-01	2.2E+00	1.4E+01	5.7E+00
	Vanadium	mg/kg	45	46	1.5E+00	1.6E+01	4.8E+01	3.5E+01
	Zinc	mg/kg	44	45	6.1E+00	2.2E+01	5.3E+01	4.3E+01

^a On-site, perimeter, and regional locations are in accordance with the Environmental Surveillance Program.

^b pCi/g is picocuries of radioactive analyte per gram of sample, nCi/l is nanocuries of radioactive analyte per liter of sample, µg/kg is micrograms of analyte per kilogram of sample, mg/kg is milligrams of analyte per kilogram of sample.

^c Upper confidence limit (UCL) not calculated when the number of detected analyses equals 1.

^d Tritium is reported as nanocuries of tritium per liter of water because tritium in sediments exists as tritiated water. The water is distilled, and the tritium content of the water is measured.

**TABLE C-5.—Sediment Detection Statistics by Watershed and Analyte
(Environmental Surveillance Report Data 1991 to 1996)**

WATERSHED ^a	ANALYTE	UNITS ^b	DETECTED	ANALYZED	MINIMUM	MEAN	MAXIMUM	95% UCL ^c
Ancho	Aluminum	mg/kg	60	60	8.4E+02	9.0E+03	3.2E+04	2.2E+04
	Americium-241	pCi/g	49	61	1.0E-03	3.4E-02	4.2E-01	2.2E-01
	Antimony	mg/kg	3	60	3.0E+00	5.0E+00	8.0E+00	1.0E+01
	Arsenic	mg/kg	59	61	2.8E-01	2.3E+00	5.5E+00	4.7E+00
	Barium	mg/kg	61	61	6.2E+00	1.7E+02	5.5E+02	4.7E+02
	Beryllium	mg/kg	37	60	1.1E-01	1.3E+00	2.9E+00	3.0E+00
	Boron	mg/kg	31	60	1.5E+00	1.1E+01	6.3E+01	3.8E+01
	Cadmium	mg/kg	8	61	3.6E-01	8.2E-01	2.3E+00	2.3E+00
	Calcium	mg/kg	1	1	3.4E+03	3.4E+03	3.4E+03	
	Cesium-137	pCi/g	80	87	4.0E-02	2.7E-01	1.0E+00	6.5E-01
	Chromium	mg/kg	59	61	1.3E+00	3.1E+01	1.2E+03	3.4E+02
	Cobalt	mg/kg	55	60	1.3E+00	5.6E+00	1.2E+01	1.1E+01
	Copper	mg/kg	45	60	1.5E+00	5.4E+00	1.2E+01	1.0E+01
	Di-n-butyl phthalate	µg/kg	1	1	6.5E+02	6.5E+02	6.5E+02	
	Gross Alpha	pCi/g	86	86	1.0E+00	5.4E+00	1.7E+01	1.1E+01
	Gross Beta	pCi/g	86	86	1.0E+00	4.7E+00	1.0E+01	8.7E+00
	Gross Gamma	pCi/g	72	88	1.0E+00	3.2E+00	1.0E+01	7.1E+00
	Iron	mg/kg	60	60	6.0E+02	8.3E+03	2.7E+04	1.9E+04
	Lead	mg/kg	47	61	1.0E+00	1.5E+01	3.4E+01	3.1E+01
	Lithium	mg/kg	1	1	1.2E+01	1.2E+01	1.2E+01	
	Magnesium	mg/kg	1	1	2.2E+03	2.2E+03	2.2E+03	
Manganese	mg/kg	60	60	4.7E+01	3.3E+02	6.6E+02	6.2E+02	
Mercury	mg/kg	20	61	1.0E-02	2.1E-02	5.0E-02	4.1E-02	
Molybdenum	mg/kg	4	60	6.0E-01	1.9E+00	2.8E+00	3.8E+00	
Nickel	mg/kg	49	60	3.2E+00	8.1E+00	1.6E+01	1.4E+01	

TABLE C-5.—Sediment Detection Statistics by Watershed and Analyte
(Environmental Surveillance Report Data 1991 to 1996)-Continued

WATERSHED ^a	ANALYTE	UNITS ^b	DETECTED	ANALYZED	MINIMUM	MEAN	MAXIMUM	95% UCL ^c
Ancho (cont.)	Plutonium-238	pCi/g	67	88	6.0E-04	6.8E-03	4.8E-02	2.5E-02
	Plutonium-239, Plutonium-240	pCi/g	88	88	1.0E-03	7.4E-02	1.7E+00	6.3E-01
	Potassium	mg/kg	1	1	2.0E+03	2.0E+03	2.0E+03	
	Selenium	mg/kg	32	61	1.2E-01	3.5E-01	5.5E-01	6.0E-01
	Silver	mg/kg	2	61	1.7E+00	2.6E+00	3.5E+00	5.2E+00
	Sodium	mg/kg	1	1	2.5E+02	2.5E+02	2.5E+02	
	Strontium	mg/kg	60	60	3.1E+00	5.7E+01	1.0E+03	3.3E+02
	Strontium-90	pCi/g	57	63	1.0E-01	4.1E-01	2.5E+00	1.2E+00
	Thallium	mg/kg	4	60	2.0E-01	1.4E+00	5.0E+00	6.2E+00
	Tin	mg/kg	14	60	7.0E+00	5.2E+01	8.6E+01	1.1E+02
	Tritium	nCi/l ^d	54	83	1.5E-02	5.9E-01	4.5E+00	2.3E+00
	Uranium	mg/kg	76	76	4.5E-01	2.2E+00	4.8E+00	4.2E+00
	Vanadium	mg/kg	60	60	2.6E+00	2.4E+01	1.1E+02	6.4E+01
	Zinc	mg/kg	60	60	6.0E+00	6.2E+01	6.5E+02	2.5E+02
	Aluminum	mg/kg	4	4	1.5E+03	2.8E+03	5.9E+03	7.0E+03
	Americium-241	pCi/g	5	5	2.0E-03	2.3E-02	1.1E-01	1.2E-01
	Bayo	Arsenic	mg/kg	3	4	4.0E-01	5.1E-01	7.3E-01
Barium		mg/kg	4	4	2.2E+01	4.5E+01	8.7E+01	1.0E+02
Beryllium		mg/kg	2	4	1.6E-01	2.7E-01	3.8E-01	5.8E-01
Boron		mg/kg	1	4	2.9E+00	2.9E+00	2.9E+00	
Cadmium		mg/kg	1	4	3.9E-01	3.9E-01	3.9E-01	
Cesium-137		pCi/g	1	6	7.0E-02	7.0E-02	7.0E-02	
Chromium		mg/kg	4	4	2.8E+00	4.2E+00	6.6E+00	7.5E+00
Cobalt		mg/kg	4	4	1.1E+00	2.4E+00	4.3E+00	5.1E+00
Copper		mg/kg	4	4	1.8E+00	3.5E+00	5.5E+00	6.6E+00

**TABLE C-5.—Sediment Detection Statistics by Watershed and Analyte
(Environmental Surveillance Report Data 1991 to 1996)-Continued**

WATERSHED ^a	ANALYTE	UNITS ^b	DETECTED	ANALYZED	MINIMUM	MEAN	MAXIMUM	95% UCL ^c
Bayo (cont.)	Gross Alpha	pCi/g	6	6	1.0E+00	1.7E+00	2.0E+00	2.7E+00
	Gross Beta	pCi/g	6	6	9.0E-01	1.5E+00	2.0E+00	2.6E+00
	Gross Gamma	pCi/g	6	6	1.0E+00	3.0E+00	7.0E+00	7.1E+00
	Iron	mg/kg	4	4	1.4E+03	3.4E+03	5.5E+03	6.7E+03
	Lead	mg/kg	1	4	8.0E+00	8.0E+00	8.0E+00	
	Manganese	mg/kg	4	4	9.8E+01	1.2E+02	1.7E+02	1.9E+02
	Molybdenum	mg/kg	1	4	1.4E+00	1.4E+00	1.4E+00	
	Nickel	mg/kg	3	4	2.0E+00	5.2E+00	9.8E+00	1.3E+01
	Plutonium-238	pCi/g	5	6	2.0E-03	7.0E-03	1.1E-02	1.5E-02
	Plutonium-239, Plutonium-240	pCi/g	6	6	2.0E-03	4.2E-03	7.0E-03	8.0E-03
	Strontium	mg/kg	4	4	4.9E+00	1.4E+01	3.9E+01	4.7E+01
	Strontium-90	pCi/g	5	6	1.0E-01	2.4E-01	5.0E-01	5.7E-01
	Tin	mg/kg	1	4	1.3E+01	1.3E+01	1.3E+01	
	Tritium	nCi/l ^d	3	3	3.0E-01	4.6E-01	7.0E-01	8.8E-01
	Uranium	mg/kg	6	6	9.3E-01	2.0E+00	2.8E+00	3.5E+00
	Vanadium	mg/kg	4	4	5.6E+00	9.6E+00	1.5E+01	1.9E+01
	Zinc	mg/kg	4	4	1.1E+01	1.4E+01	2.2E+01	2.5E+01
Cañada del Buey	Aluminum	mg/kg	13	13	1.8E+03	5.0E+03	2.1E+04	1.5E+04
	Americium-241	pCi/g	15	16	2.0E-03	2.6E-02	1.5E-01	9.8E-02
	Arsenic	mg/kg	13	13	3.0E-01	9.5E-01	3.0E+00	2.3E+00
	Barium	mg/kg	13	13	1.7E+01	4.0E+01	8.3E+01	8.0E+01
	Beryllium	mg/kg	9	13	1.1E-01	5.5E-01	1.4E+00	1.4E+00
	Bis(2-ethylhexyl) phthalate	µg/kg	2	9	3.5E+02	3.5E+02	3.5E+02	3.5E+02
	Boron	mg/kg	8	13	1.3E+00	2.5E+00	5.4E+00	5.1E+00

**TABLE C-5.—Sediment Detection Statistics by Watershed and Analyte
(Environmental Surveillance Report Data 1991 to 1996)-Continued**

WATERSHED^a	ANALYTE	UNITS^b	DETECTED	ANALYZED	MINIMUM	MEAN	MAXIMUM	95% UCL^c
Cañada del Buey (cont.)	Cadmium	mg/kg	4	13	2.0E-01	4.8E-01	1.1E+00	1.3E+00
	Cesium-137	pCi/g	20	24	4.0E-02	2.1E-01	6.0E-01	5.0E-01
	Chromium	mg/kg	13	13	1.4E+00	4.0E+00	1.3E+01	1.0E+01
	Cobalt	mg/kg	13	13	5.2E-01	2.7E+00	4.9E+00	5.6E+00
	Copper	mg/kg	8	13	6.7E-01	2.4E+00	5.2E+00	5.5E+00
	Di-n-butyl phthalate	µg/kg	6	9	4.6E+02	7.1E+02	1.0E+03	1.2E+03
	Gross Alpha	pCi/g	24	24	1.9E+00	4.2E+00	1.0E+01	7.9E+00
	Gross Beta	pCi/g	23	24	1.4E+00	2.8E+00	7.0E+00	5.4E+00
	Gross Gamma	pCi/g	21	24	1.0E+00	5.7E+00	2.1E+01	1.6E+01
	Iron	mg/kg	13	13	2.4E+01	5.2E+03	1.5E+04	1.3E+04
	Lead	mg/kg	11	13	3.4E+00	6.9E+00	9.2E+00	1.0E+01
	Manganese	mg/kg	13	13	8.0E+01	1.9E+02	3.1E+02	3.4E+02
	Mercury	mg/kg	1	13	2.0E-02	2.0E-02	2.0E-02	
	Nickel	mg/kg	8	13	1.1E+00	4.7E+00	1.0E+01	1.0E+01
	Plutonium-238	pCi/g	24	24	1.0E-03	5.7E-02	2.4E-01	2.0E-01
	Plutonium-239, Plutonium-240	pCi/g	24	24	2.0E-03	6.7E-02	2.3E-01	2.1E-01
	Selenium	mg/kg	3	13	3.0E-01	4.0E-01	5.0E-01	6.0E-01
	Strontium	mg/kg	13	13	3.2E+00	7.7E+00	2.0E+01	1.8E+01
	Strontium-90	pCi/g	12	18	1.0E-01	2.2E-01	4.0E-01	4.6E-01
	Thallium	mg/kg	1	13	2.0E-01	2.0E-01	2.0E-01	
Tin	mg/kg	1	13	8.0E+00	8.0E+00	8.0E+00		
Tritium	nCi/l ^d	17	19	2.0E-01	1.4E+00	3.7E+00	3.9E+00	

**TABLE C-5.—Sediment Detection Statistics by Watershed and Analyte
(Environmental Surveillance Report Data 1991 to 1996)-Continued**

WATERSHED ^a	ANALYTE	UNITS ^b	DETECTED	ANALYZED	MINIMUM	MEAN	MAXIMUM	95% UCL ^c
Cañada del Buey (cont.)	Uranium	mg/kg	24	24	4.0E-01	2.0E+00	4.4E+00	4.1E+00
	Vanadium	mg/kg	13	13	1.8E+00	8.2E+00	2.4E+01	2.0E+01
	Zinc	mg/kg	13	13	1.1E+01	2.8E+01	6.0E+01	5.5E+01
Chaquehui	Aluminum	mg/kg	4	4	3.1E+03	6.3E+03	1.2E+04	1.4E+04
	Americium-241	pCi/g	3	3	3.0E-03	5.3E-03	1.0E-02	1.3E-02
	Arsenic	mg/kg	4	5	7.0E-01	1.6E+00	3.0E+00	3.9E+00
	Barium	mg/kg	5	5	5.5E+01	1.5E+02	3.2E+02	3.6E+02
	Beryllium	mg/kg	4	4	3.1E-01	5.3E-01	8.9E-01	1.0E+00
	Boron	mg/kg	2	4	3.0E+00	3.7E+00	4.4E+00	5.7E+00
	Cadmium	mg/kg	1	5	1.3E+00	1.3E+00	1.3E+00	
	Calcium	mg/kg	1	1	4.6E+03	4.6E+03	4.6E+03	
	Cesium-137	pCi/g	5	5	1.0E-01	2.8E-01	6.1E-01	7.2E-01
	Chromium	mg/kg	5	5	3.1E+00	5.8E+00	9.1E+00	1.1E+01
	Cobalt	mg/kg	4	4	2.6E+00	4.0E+00	5.1E+00	6.1E+00
	Copper	mg/kg	4	4	4.9E+00	7.7E+00	1.3E+01	1.5E+01
	Gross Alpha	pCi/g	5	5	3.0E+00	4.2E+00	9.0E+00	9.6E+00
	Gross Beta	pCi/g	5	5	2.0E+00	3.4E+00	6.0E+00	6.7E+00
	Gross Gamma	pCi/g	5	5	2.6E+00	3.2E+00	4.3E+00	4.5E+00
	Iron	mg/kg	4	4	6.0E+03	1.0E+04	1.4E+04	1.7E+04
Lead	mg/kg	4	5	3.8E+00	7.7E+00	1.4E+01	1.7E+01	
Lithium	mg/kg	1	1	1.4E+01	1.4E+01	1.4E+01		
Magnesium	mg/kg	1	1	2.4E+03	2.4E+03	2.4E+03		
Manganese	mg/kg	4	4	1.3E+02	2.6E+02	3.5E+02	4.6E+02	
Mercury	mg/kg	2	5	3.0E-02	4.0E-02	5.0E-02	6.8E-02	
Molybdenum	mg/kg	2	4	1.8E+00	2.9E+00	4.0E+00	6.0E+00	

TABLE C-5.—Sediment Detection Statistics by Watershed and Analyte
(Environmental Surveillance Report Data 1991 to 1996)-Continued

WATERSHED ^a	ANALYTE	UNITS ^b	DETECTED	ANALYZED	MINIMUM	MEAN	MAXIMUM	95% UCL ^c
Chaquehui (cont.)	Nickel	mg/kg	4	4	3.8E+00	7.0E+00	1.1E+01	1.3E+01
	Plutonium-238	pCi/g	4	5	1.0E-03	7.0E-03	1.8E-02	2.2E-02
	Plutonium-239, Plutonium-240	pCi/g	5	5	4.0E-03	1.1E-02	2.8E-02	3.1E-02
	Potassium	mg/kg	1	1	2.7E+03	2.7E+03	2.7E+03	
	Selenium	mg/kg	2	5	3.8E-01	4.9E-01	6.0E-01	8.0E-01
	Silver	mg/kg	1	5	1.8E+00	1.8E+00	1.8E+00	
	Sodium	mg/kg	1	1	2.6E+02	2.6E+02	2.6E+02	
	Strontium	mg/kg	4	4	1.0E+01	3.1E+01	6.5E+01	8.1E+01
	Strontium-90	pCi/g	4	4	1.0E-01	3.8E-01	1.0E+00	1.2E+00
	Thallium	mg/kg	2	4	7.0E-02	1.6E-01	2.5E-01	4.1E-01
	Tin	mg/kg	1	4	9.6E+00	9.6E+00	9.6E+00	
	Tritium	nCi/l ^d	3	5	3.0E-01	1.1E+01	2.8E+01	4.1E+01
	Uranium	mg/kg	5	5	1.4E+00	2.2E+00	2.9E+00	3.4E+00
	Vanadium	mg/kg	4	4	6.5E+00	1.4E+01	2.0E+01	2.5E+01
Frijoles	Zinc	mg/kg	4	4	1.9E+01	3.4E+01	4.7E+01	6.2E+01
	Aluminum	mg/kg	9	9	3.8E+02	5.8E+03	1.5E+04	1.6E+04
	Americium-241	pCi/g	7	9	3.0E-03	2.4E-02	1.4E-01	1.2E-01
	Arsenic	mg/kg	7	10	2.1E-01	1.5E+00	4.0E+00	4.5E+00
	Barium	mg/kg	10	10	4.9E+00	7.0E+01	2.1E+02	2.2E+02
	Beryllium	mg/kg	8	9	1.0E-01	4.9E-01	1.2E+00	1.3E+00
	Boron	mg/kg	3	9	8.6E-01	1.5E+00	1.9E+00	2.6E+00
	Cadmium	mg/kg	2	10	2.2E-01	3.8E-01	5.4E-01	8.3E-01
	Calcium	mg/kg	1	1	1.3E+04	1.3E+04	1.3E+04	
	Cesium-137	pCi/g	10	12	7.0E-02	2.0E-01	5.0E-01	4.8E-01
	Chromium	mg/kg	10	10	5.8E-01	4.7E+00	1.3E+01	1.3E+01

**TABLE C-5.—Sediment Detection Statistics by Watershed and Analyte
(Environmental Surveillance Report Data 1991 to 1996)-Continued**

WATERSHED ^a	ANALYTE	UNITS ^b	DETECTED	ANALYZED	MINIMUM	MEAN	MAXIMUM	95% UCL ^c
Frijoles (cont.)	Cobalt	mg/kg	9	9	7.3E-01	3.0E+00	6.7E+00	7.1E+00
	Copper	mg/kg	7	9	1.0E+00	5.9E+00	1.4E+01	1.5E+01
	Gross Alpha	pCi/g	11	11	4.1E-01	2.2E+00	4.0E+00	4.4E+00
	Gross Beta	pCi/g	11	11	1.0E+00	1.8E+00	5.0E+00	4.1E+00
	Gross Gamma	pCi/g	12	12	2.0E+00	3.5E+00	7.0E+00	6.6E+00
	Iron	mg/kg	9	9	8.2E+02	6.7E+03	1.6E+04	1.7E+04
	Lead	mg/kg	8	10	3.0E+00	9.5E+00	2.0E+01	2.3E+01
	Lithium	mg/kg	1	1	2.0E+01	2.0E+01	2.0E+01	
	Magnesium	mg/kg	1	1	4.1E+03	4.1E+03	4.1E+03	
	Manganese	mg/kg	9	9	3.7E+01	2.7E+02	6.4E+02	6.9E+02
	Mercury	mg/kg	3	10	2.0E-02	3.0E-02	4.0E-02	5.0E-02
	Nickel	mg/kg	5	9	1.5E+00	5.4E+00	1.1E+01	1.3E+01
	Plutonium-238	pCi/g	9	12	4.0E-04	5.0E-03	1.6E-02	1.6E-02
	Plutonium-239, Plutonium-240	pCi/g	12	12	2.0E-03	6.0E-03	2.0E-02	1.5E-02
	Potassium	mg/kg	1	1	2.6E+03	2.6E+03	2.6E+03	
	Selenium	mg/kg	4	10	6.0E-01	7.8E-01	1.1E+00	1.2E+00
	Silver	mg/kg	2	10	2.4E+00	1.5E+01	2.7E+01	4.9E+01
	Sodium	mg/kg	1	1	3.6E+02	3.6E+02	3.6E+02	
	Strontium	mg/kg	9	9	1.4E+00	1.9E+01	6.3E+01	6.1E+01
	Strontium-90	pCi/g	8	10	1.0E-01	3.0E-01	1.3E+00	1.1E+00
	Thallium	mg/kg	1	9	3.0E-01	3.0E-01	3.0E-01	
	Tin	mg/kg	3	9	3.6E+00	5.6E+00	7.1E+00	9.1E+00
	Tritium	nCi/l ^d	5	11	1.0E-01	3.6E-01	9.6E-01	1.0E+00
Uranium	mg/kg	12	12	1.2E+00	2.3E+00	4.6E+00	4.1E+00	

TABLE C-5.—Sediment Detection Statistics by Watershed and Analyte
(Environmental Surveillance Report Data 1991 to 1996)-Continued

WATERSHED ^a	ANALYTE	UNITS ^b	DETECTED	ANALYZED	MINIMUM	MEAN	MAXIMUM	95% UCL ^c
Guaje	Vanadium	mg/kg	8	9	2.0E+00	1.1E+01	2.3E+01	2.7E+01
	Zinc	mg/kg	9	9	5.5E+00	3.5E+01	8.1E+01	8.5E+01
	Aluminum	mg/kg	4	4	1.7E+03	2.9E+03	5.5E+03	6.4E+03
	Americium-241	pCi/g	3	5	1.0E-03	1.7E-03	2.0E-03	2.8E-03
	Arsenic	mg/kg	4	4	4.0E-01	4.9E-01	6.0E-01	6.6E-01
	Barium	mg/kg	4	4	2.1E+01	3.5E+01	5.3E+01	6.8E+01
	Beryllium	mg/kg	2	4	1.7E-01	2.6E-01	3.4E-01	5.0E-01
	Cadmium	mg/kg	1	4	3.2E-01	3.2E-01	3.2E-01	
	Cesium-137	pCi/g	4	6	4.0E-02	7.5E-02	1.0E-01	1.4E-01
	Chromium	mg/kg	4	4	2.7E+00	6.1E+00	1.2E+01	1.4E+01
	Cobalt	mg/kg	4	4	2.2E+00	2.5E+00	3.0E+00	3.2E+00
	Copper	mg/kg	3	4	2.4E+00	4.3E+00	7.3E+00	9.6E+00
	Gross Alpha	pCi/g	6	6	1.7E+00	2.3E+00	3.0E+00	3.4E+00
	Gross Beta	pCi/g	6	6	1.0E+00	1.7E+00	3.0E+00	3.2E+00
	Gross Gamma	pCi/g	6	6	1.0E+00	3.2E+00	9.0E+00	9.1E+00
	Iron	mg/kg	4	4	6.2E+02	7.4E+03	1.7E+04	2.1E+04
	Lead	mg/kg	2	4	6.0E+00	7.2E+00	8.3E+00	1.0E+01
	Manganese	mg/kg	4	4	8.8E+01	1.7E+02	3.2E+02	3.8E+02
	Molybdenum	mg/kg	1	4	1.4E+00	1.4E+00	1.4E+00	
	Nickel	mg/kg	3	4	3.1E+00	5.9E+00	9.1E+00	1.2E+01
Plutonium-238	pCi/g	6	6	1.0E-03	6.3E-03	1.5E-02	1.8E-02	
Plutonium-239, Plutonium-240	pCi/g	6	6	1.0E-03	3.5E-02	1.9E-01	1.9E-01	

**TABLE C-5.—Sediment Detection Statistics by Watershed and Analyte
(Environmental Surveillance Report Data 1991 to 1996)-Continued**

WATERSHED ^a	ANALYTE	UNITS ^b	DETECTED	ANALYZED	MINIMUM	MEAN	MAXIMUM	95% UCL ^c
Guaje (cont.)	Selenium	mg/kg	1	4	5.0E-01	5.0E-01	5.0E-01	
	Silver	mg/kg	1	4	2.9E+00	2.9E+00	2.9E+00	
	Strontium	mg/kg	4	4	5.7E+00	1.2E+01	2.5E+01	3.0E+01
	Strontium-90	pCi/g	6	6	1.0E-01	6.3E-01	2.9E+00	2.9E+00
	Tin	mg/kg	1	4	8.2E+00	8.2E+00	8.2E+00	
	Tritium	nCi/l ^d	3	3	1.0E-01	4.3E-01	1.0E+00	1.4E+00
	Uranium	mg/kg	6	6	1.5E+00	2.0E+00	2.4E+00	2.6E+00
	Vanadium	mg/kg	4	4	5.5E+00	1.6E+01	3.3E+01	4.0E+01
	Zinc	mg/kg	4	4	1.2E+01	3.2E+01	7.5E+01	9.0E+01
	Aluminum	mg/kg	59	59	6.1E+02	2.9E+03	7.1E+03	6.5E+03
	Americium-241	pCi/g	61	62	1.0E-03	1.1E-01	4.9E-01	3.6E-01
	Arsenic	mg/kg	53	59	3.2E-01	2.1E+00	6.5E+01	2.0E+01
	Barium	mg/kg	59	59	7.2E+00	3.3E+01	2.6E+02	1.0E+02
	Beryllium	mg/kg	47	59	1.1E-01	2.9E-01	5.7E-01	5.5E-01
Los Alamos	Boron	mg/kg	19	59	5.0E-01	8.3E+00	3.7E+01	3.2E+01
	Cadmium	mg/kg	3	59	4.6E-01	6.0E-01	8.0E-01	9.6E-01
	Calcium	mg/kg	8	8	1.8E+02	5.3E+02	1.0E+03	1.1E+03
	Cesium-137	pCi/g	58	72	2.0E-02	9.2E-01	4.0E+00	2.8E+00
	Chromium	mg/kg	57	58	1.1E+00	3.4E+00	1.5E+01	8.1E+00
	Cobalt	mg/kg	56	59	7.7E-01	2.7E+00	1.3E+01	6.8E+00
	Copper	mg/kg	46	59	1.0E+00	3.6E+00	1.1E+01	8.0E+00
	Gross Alpha	pCi/g	73	73	8.0E-01	2.5E+00	6.1E+00	4.9E+00
	Gross Beta	pCi/g	71	72	5.0E-01	2.2E+00	6.0E+00	5.0E+00
	Gross Gamma	pCi/g	63	73	1.0E+00	4.1E+00	1.4E+01	1.1E+01
	Iron	mg/kg	59	59	5.3E+02	4.2E+03	2.2E+04	1.1E+04
	Lead	mg/kg	48	59	2.0E+00	1.1E+01	2.8E+01	2.2E+01

TABLE C-5.—Sediment Detection Statistics by Watershed and Analyte
(Environmental Surveillance Report Data 1991 to 1996)-Continued

WATERSHED ^a	ANALYTE	UNITS ^b	DETECTED	ANALYZED	MINIMUM	MEAN	MAXIMUM	95% UCL ^c	
Los Alamos (cont.)	Lithium	mg/kg	8	8	1.2E+00	3.5E+00	5.4E+00	6.2E+00	
	Magnesium	mg/kg	8	8	1.2E+02	4.0E+02	7.2E+02	8.2E+02	
	Manganese	mg/kg	59	59	5.4E+01	1.5E+02	4.0E+02	2.9E+02	
	Mercury	mg/kg	14	51	1.0E-02	3.5E-02	1.2E-01	1.0E-01	
	Molybdenum	mg/kg	13	59	3.3E-01	8.4E-01	1.8E+00	1.9E+00	
	Nickel	mg/kg	27	59	2.1E+00	4.5E+00	1.5E+01	1.1E+01	
	Plutonium-238	pCi/g	69	72	3.0E-04	1.6E-02	6.4E-02	4.7E-02	
	Plutonium-239, Plutonium-240	pCi/g	71	72	1.0E-03	1.5E-01	1.3E+00	4.9E-01	
	Potassium	mg/kg	7	8	1.3E+02	3.3E+02	5.5E+02	6.1E+02	
	Selenium	mg/kg	18	59	1.9E-01	4.2E+00	6.8E+01	3.6E+01	
	Silver	mg/kg	8	59	3.5E-01	7.5E+00	1.5E+01	1.7E+01	
	Sodium	mg/kg	8	8	3.1E+01	8.1E+01	1.3E+02	1.7E+02	
	Strontium	mg/kg	59	59	1.8E+00	7.8E+00	4.1E+01	2.1E+01	
	Strontium-90	pCi/g	64	73	1.0E-01	3.3E-01	4.0E+00	1.3E+00	
	Thallium	mg/kg	2	59	1.0E-01	3.5E-01	6.0E-01	1.1E+00	
	Tin	mg/kg	13	59	3.4E+00	8.3E+00	1.3E+01	1.4E+01	
	Tritium	nCi/l ^d	32	51	1.0E-01	7.9E-01	5.4E+00	2.7E+00	
	Uranium	mg/kg	71	71	7.7E-01	1.8E+00	4.4E+00	3.4E+00	
	Vanadium	mg/kg	58	59	1.6E+00	6.6E+00	4.2E+01	1.8E+01	
	Zinc	mg/kg	59	59	8.0E+00	2.8E+01	9.3E+01	5.7E+01	
	Mortandad	Aluminum	mg/kg	87	87	8.5E+02	5.5E+03	1.9E+04	1.3E+04
		Americium-241	pCi/g	83	86	1.0E-03	1.0E+00	1.2E+01	6.1E+00
		Antimony	mg/kg	5	86	3.0E-02	1.3E-01	3.0E-01	4.0E-01
Arsenic		mg/kg	81	88	3.0E-01	1.5E+00	4.6E+00	3.2E+00	
Barium		mg/kg	88	88	9.8E+00	6.0E+01	5.2E+02	1.8E+02	
Beryllium		mg/kg	80	87	1.1E-01	5.3E-01	1.8E+00	1.2E+00	
Boron		mg/kg	47	87	1.0E+00	7.3E+00	1.2E+02	4.2E+01	

**TABLE C-5.—Sediment Detection Statistics by Watershed and Analyte
(Environmental Surveillance Report Data 1991 to 1996)-Continued**

WATERSHED ^a	ANALYTE	UNITS ^b	DETECTED	ANALYZED	MINIMUM	MEAN	MAXIMUM	95% UCL ^c
Mortandad (cont.)	Cadmium	mg/kg	15	88	1.8E-01	7.4E-01	1.7E+00	1.5E+00
	Calcium	mg/kg	8	8	2.9E+02	1.5E+03	5.7E+03	5.3E+03
	Cesium-137	pCi/g	85	101	3.0E-02	4.7E+00	1.1E+02	3.2E+01
	Chromium	mg/kg	88	88\	8.1E-01	4.2E+00	1.1E+01	8.9E+00
	Cobalt	mg/kg	86	87	5.9E-01	3.2E+00	1.8E+01	8.1E+00
	Copper	mg/kg	72	87	5.0E-01	5.4E+00	4.4E+01	1.9E+01
	Cyanide	mg/kg	2	5	7.5E-02	1.5E-01	2.3E-01	3.7E-01
	Gross Alpha	pCi/g	98	98	1.0E+00	8.6E+00	5.4E+01	2.9E+01
	Gross Beta	pCi/g	98	98	1.0E+00	8.0E+00	8.9E+01	3.1E+01
	Gross Gamma	pCi/g	95	101	1.0E+00	9.2E+00	1.1E+02	3.5E+01
	Iron	mg/kg	87	87	5.0E+02	6.6E+03	1.8E+04	1.4E+04
	Lead	mg/kg	69	88	1.0E+00	1.1E+01	2.6E+01	2.0E+01
	Lithium	mg/kg	13	13	2.6E+00	7.8E+00	1.3E+01	1.6E+01
	Magnesium	mg/kg	13	13	1.8E+02	7.2E+02	2.9E+03	2.2E+03
	Manganese	mg/kg	87	87	7.9E+01	2.7E+02	6.4E+02	5.2E+02
	Mercury	mg/kg	19	81	1.0E-02	2.9E-02	5.0E-02	4.9E-02
	Molybdenum	mg/kg	23	87	4.5E-01	1.4E+00	2.6E+00	2.8E+00
	Nickel	mg/kg	50	87	1.6E+00	5.4E+00	1.3E+01	9.8E+00
	Plutonium-238	pCi/g	96	102	3.0E-04	4.6E-01	6.8E+00	2.9E+00
	Plutonium-239, Plutonium-240	pCi/g	101	102	1.0E-03	1.0E+00	1.7E+01	6.4E+00
	Potassium	mg/kg	13	13	1.5E+02	6.9E+02	2.2E+03	1.8E+03
	Selenium	mg/kg	25	87	2.0E-01	3.9E-01	7.3E-01	6.6E-01
	Silver	mg/kg	3	88	5.3E-01	1.1E+00	1.9E+00	2.5E+00
Sodium	mg/kg	8	8	4.2E+01	9.0E+01	2.6E+02	2.4E+02	
Strontium	mg/kg	85	86	1.6E+00	1.1E+01	3.6E+01	2.6E+01	

TABLE C-5.—Sediment Detection Statistics by Watershed and Analyte
(Environmental Surveillance Report Data 1991 to 1996)-Continued

WATERSHED ^a	ANALYTE	UNITS ^b	DETECTED	ANALYZED	MINIMUM	MEAN	MAXIMUM	95% UCL ^c
Mortandad (cont.)	Strontium-90	pCi/g	87	99	1.0E-01	4.5E-01	3.9E+00	1.7E+00
	Thallium	mg/kg	21	86	5.0E-02	4.9E-01	5.0E+00	2.8E+00
	Tin	mg/kg	32	86	4.0E+00	1.2E+01	3.5E+01	2.5E+01
	Tritium	nCi/l ^d	68	90	1.0E-01	6.4E+00	9.4E+01	4.3E+01
	Uranium	mg/kg	88	88	3.2E-01	2.2E+00	5.4E+00	4.4E+00
	Vanadium	mg/kg	85	86	1.5E+00	8.8E+00	2.4E+01	1.9E+01
	Zinc	mg/kg	86	86	9.3E+00	4.3E+01	3.3E+02	1.2E+02
	Aluminum	mg/kg	30	30	1.0E+03	5.0E+03	1.5E+04	1.1E+04
	Americium-241	pCi/g	36	37	1.0E-03	9.5E-03	4.9E-02	3.2E-02
	Arsenic	mg/kg	29	31	3.2E-01	1.2E+00	3.0E+00	2.3E+00
Pajarito	Barium	mg/kg	31	31	1.1E+01	6.3E+01	5.3E+02	2.5E+02
	Beryllium	mg/kg	26	30	1.1E-01	3.6E-01	7.4E-01	7.4E-01
	Boron	mg/kg	19	30	1.4E+00	4.0E+00	2.2E+01	1.3E+01
	Cadmium	mg/kg	7	31	2.0E-01	5.8E-01	1.8E+00	1.7E+00
	Calcium	mg/kg	1	1	5.6E+02	5.6E+02	5.6E+02	
	Cesium-137	pCi/g	44	52	3.0E-02	2.2E-01	1.2E+00	6.1E-01
	Chromium	mg/kg	30	31	1.6E+00	5.1E+00	1.4E+01	1.0E+01
	Cobalt	mg/kg	29	30	6.5E-01	3.1E+00	1.1E+01	7.5E+00
	Copper	mg/kg	25	30	9.5E-01	3.0E+00	1.2E+01	7.7E+00
	Di-n-butyl phthalate	µg/kg	12	18	3.9E+02	5.7E+02	8.7E+02	9.1E+02
	Gross Alpha	pCi/g	52	52	1.0E+00	4.5E+00	1.3E+01	8.9E+00
	Gross Beta	pCi/g	52	52	7.0E-01	3.0E+00	7.0E+00	5.9E+00
	Gross Gamma	pCi/g	49	52	1.0E+00	3.7E+00	1.3E+01	8.6E+00
	Iron	mg/kg	30	30	2.0E+03	7.3E+03	1.6E+04	1.4E+04
	Lead	mg/kg	25	31	1.2E+00	1.7E+01	1.4E+02	7.1E+01

TABLE C-5.—Sediment Detection Statistics by Watershed and Analyte
(Environmental Surveillance Report Data 1991 to 1996)-Continued

WATERSHED ^a	ANALYTE	UNITS ^b	DETECTED	ANALYZED	MINIMUM	MEAN	MAXIMUM	95% UCL ^c
Pajarito (cont.)	Lithium	mg/kg	1	1	3.0E+00	3.0E+00	3.0E+00	
	Magnesium	mg/kg	1	1	3.9E+02	3.9E+02	3.9E+02	
	Manganese	mg/kg	30	30	4.6E+01	2.3E+02	6.2E+02	4.7E+02
	Mercury	mg/kg	6	31	1.0E-02	2.3E-02	4.0E-02	4.4E-02
	Molybdenum	mg/kg	5	30	5.0E-01	2.4E+00	5.5E+00	6.1E+00
	Nickel	mg/kg	15	30	3.0E+00	4.8E+00	9.9E+00	8.7E+00
	Plutonium-238	pCi/g	50	52	1.0E-03	7.6E-03	3.6E-02	2.2E-02
	Plutonium-239, Plutonium-240	pCi/g	52	52	1.0E-03	2.9E-02	2.3E-01	1.2E-01
	Potassium	mg/kg	1	1	2.7E+02	2.7E+02	2.7E+02	
	Selenium	mg/kg	9	31	1.0E-01	3.2E-01	5.0E-01	6.3E-01
	Sodium	mg/kg	1	1	8.0E+01	8.0E+01	8.0E+01	
	Strontium	mg/kg	30	30	2.2E+00	9.4E+00	3.1E+01	2.1E+01
	Strontium-90	pCi/g	30	39	1.0E-01	2.2E-01	9.0E-01	5.4E-01
	Thallium	mg/kg	3	30	2.0E-01	3.7E-01	6.5E-01	8.6E-01
	Tin	mg/kg	2	30	6.0E+00	9.0E+00	1.2E+01	1.7E+01
	Tritium	nCi/l ^d	42	49	7.5E-02	1.9E+00	6.6E+00	6.0E+00
	Uranium	mg/kg	52	52	6.0E-01	1.9E+00	4.5E+00	3.8E+00
	Vanadium	mg/kg	30	30	1.8E+00	9.9E+00	2.5E+01	2.0E+01
	Zinc	mg/kg	30	30	9.2E+00	5.2E+01	3.9E+02	1.9E+02
	Potrillo	Aluminum	mg/kg	2	2	5.0E+03	6.1E+03	7.3E+03
Americium-241		pCi/g	3	3	2.0E-03	4.3E-03	7.0E-03	9.4E-03
Arsenic		mg/kg	2	2	1.6E+00	1.7E+00	1.7E+00	1.8E+00
Barium		mg/kg	2	2	6.7E+01	7.0E+01	7.3E+01	7.7E+01
Beryllium		mg/kg	2	2	2.7E-01	5.2E-01	7.6E-01	1.2E+00
Boron		mg/kg	1	2	2.8E+00	2.8E+00	2.8E+00	

TABLE C-5.—Sediment Detection Statistics by Watershed and Analyte
(Environmental Surveillance Report Data 1991 to 1996)-Continued

WATERSHED ^a	ANALYTE	UNITS ^b	DETECTED	ANALYZED	MINIMUM	MEAN	MAXIMUM	95% UCL ^c
Potrillo (cont.)	Cadmium	mg/kg	1	2	5.4E-01	5.4E-01	5.4E-01	
	Cesium-137	pCi/g	3	3	1.0E-01	2.1E-01	4.0E-01	5.4E-01
	Chromium	mg/kg	2	2	3.1E+00	4.7E+00	6.3E+00	9.2E+00
	Cobalt	mg/kg	2	2	2.0E+00	2.5E+00	2.9E+00	3.7E+00
	Copper	mg/kg	2	2	3.2E+00	4.2E+00	5.2E+00	7.0E+00
	Gross Alpha	pCi/g	3	3	4.0E+00	4.4E+00	4.8E+00	5.2E+00
	Gross Beta	pCi/g	3	3	3.5E+00	3.8E+00	4.0E+00	4.3E+00
	Gross Gamma	pCi/g	3	3	3.0E+00	4.6E+00	6.0E+00	7.6E+00
	Iron	mg/kg	2	2	5.9E+03	6.7E+03	7.6E+03	9.1E+03
	Lead	mg/kg	2	2	5.7E+00	7.6E+00	9.4E+00	1.3E+01
	Manganese	mg/kg	2	2	2.0E+02	2.1E+02	2.3E+02	2.5E+02
	Mercury	mg/kg	1	2	2.0E-02	2.0E-02	2.0E-02	
	Molybdenum	mg/kg	1	2	1.1E+00	1.1E+00	1.1E+00	
	Nickel	mg/kg	2	2	4.0E+00	5.3E+00	6.5E+00	8.8E+00
	Plutonium-238	pCi/g	3	3	1.0E-03	1.2E-02	2.9E-02	4.2E-02
	Plutonium-239, Plutonium-240	pCi/g	3	3	5.0E-03	8.7E-03	1.1E-02	1.5E-02
	Selenium	mg/kg	1	2	7.0E-01	7.0E-01	7.0E-01	
	Strontium	mg/kg	2	2	1.0E+01	1.1E+01	1.2E+01	1.4E+01
	Strontium-90	pCi/g	3	3	2.0E-01	3.0E-01	4.0E-01	5.0E-01
	Thallium	mg/kg	2	2	3.0E-01	4.5E-01	6.0E-01	8.7E-01
	Tin	mg/kg	1	2	2.4E+00	2.4E+00	2.4E+00	
	Tritium	nCi/l ^d	2	3	1.3E-02	6.6E-01	1.3E+00	2.5E+00
	Uranium	mg/kg	3	3	1.8E+00	2.5E+00	3.2E+00	3.8E+00
Vanadium	mg/kg	2	2	6.3E+00	8.2E+00	1.0E+01	1.4E+01	
Zinc	mg/kg	2	2	2.4E+01	2.9E+01	3.5E+01	4.4E+01	

**TABLE C-5.—Sediment Detection Statistics by Watershed and Analyte
(Environmental Surveillance Report Data 1991 to 1996)-Continued**

WATERSHED ^a	ANALYTE	UNITS ^b	DETECTED	ANALYZED	MINIMUM	MEAN	MAXIMUM	95% UCL ^c
Pueblo	Aluminum	mg/kg	30	30	1.1E+03	3.0E+03	6.3E+03	6.7E+03
	Americium-241	pCi/g	29	31	2.0E-03	1.0E-01	5.3E-01	4.2E-01
	Antimony	mg/kg	1	31	6.0E+00	6.0E+00	6.0E+00	
	Arsenic	mg/kg	29	31	3.5E-01	7.7E-01	1.6E+00	1.4E+00
	Barium	mg/kg	30	30	1.2E+01	2.9E+01	9.2E+01	6.0E+01
	Beryllium	mg/kg	22	31	2.0E-02	3.5E-01	7.0E-01	7.2E-01
	Boron	mg/kg	7	30	3.6E+00	1.0E+01	2.3E+01	2.7E+01
	Cadmium	mg/kg	6	31	5.0E-01	6.7E-01	8.0E-01	9.0E-01
	Calcium	mg/kg	6	6	3.1E+02	8.8E+02	2.7E+03	2.7E+03
	Cesium-137	pCi/g	29	37	1.0E-02	2.5E-01	3.1E+00	1.4E+00
	Chromium	mg/kg	31	31	1.4E+00	3.3E+00	1.3E+01	8.1E+00
	Cobalt	mg/kg	28	30	9.4E-01	2.8E+00	7.1E+00	6.3E+00
	Copper	mg/kg	27	31	1.1E+00	4.0E+00	3.3E+01	1.6E+01
	Gross Alpha	pCi/g	37	37	2.0E+00	4.3E+00	1.4E+01	1.0E+01
	Gross Beta	pCi/g	37	37	3.0E-01	1.8E+00	4.0E+00	3.5E+00
	Gross Gamma	pCi/g	33	37	1.0E+00	4.2E+00	1.5E+01	1.1E+01
	Iron	mg/kg	31	31	7.5E+02	6.3E+03	2.5E+04	1.8E+04
	Lead	mg/kg	29	30	4.1E+00	1.5E+01	6.0E+01	3.9E+01
	Lithium	mg/kg	6	6	2.9E+00	1.4E+01	5.1E+01	5.1E+01
	Magnesium	mg/kg	6	6	2.4E+02	4.9E+02	1.2E+03	1.2E+03
Manganese	mg/kg	31	31	4.7E+01	2.4E+02	6.5E+02	5.1E+02	
Mercury	mg/kg	7	25	1.0E-02	4.9E-02	2.0E-01	1.8E-01	
Molybdenum	mg/kg	7	31	3.0E-01	3.3E+00	1.4E+01	1.3E+01	

TABLE C-5.—Sediment Detection Statistics by Watershed and Analyte
(Environmental Surveillance Report Data 1991 to 1996)-Continued

WATERSHED ^a	ANALYTE	UNITS ^b	DETECTED	ANALYZED	MINIMUM	MEAN	MAXIMUM	95% UCL ^c
Pueblo (cont.)	Nickel	mg/kg	9	30	1.5E+00	4.3E+00	9.4E+00	1.1E+01
	Plutonium-238	pCi/g	35	37	2.0E-04	1.4E-02	6.1E-02	4.6E-02
	Plutonium-239, Plutonium-240	pCi/g	37	37	2.7E-03	1.7E+00	1.2E+01	7.7E+00
	Potassium	mg/kg	6	6	2.3E+02	5.1E+02	1.0E+03	1.1E+03
	Selenium	mg/kg	8	31	2.0E-01	3.8E-01	5.0E-01	6.1E-01
	Silver	mg/kg	5	31	6.0E-01	2.6E+00	4.0E+00	5.3E+00
	Sodium	mg/kg	6	6	8.7E+01	1.8E+02	3.1E+02	3.6E+02
	Strontium	mg/kg	30	30	2.3E+00	7.3E+00	3.8E+01	2.1E+01
	Strontium-90	pCi/g	29	37	1.0E-01	4.7E-01	5.0E+00	2.3E+00
	Thallium	mg/kg	1	31	1.8E+01	1.8E+01	1.8E+01	
	Tin	mg/kg	9	30	3.1E+00	9.1E+00	1.5E+01	1.6E+01
	Tritium	nCi/l ^d	17	27	1.0E-01	6.8E-01	3.6E+00	2.3E+00
	Uranium	mg/kg	36	36	7.7E-01	2.2E+00	5.9E+00	4.3E+00
	Vanadium	mg/kg	30	30	2.5E+00	6.7E+00	1.7E+01	1.4E+01
Sandia	Zinc	mg/kg	31	31	1.3E+01	4.6E+01	1.4E+02	1.1E+02
	Aluminum	mg/kg	17	17	1.6E+03	3.2E+03	7.1E+03	6.2E+03
	Americium-241	pCi/g	17	17	1.0E-03	1.6E-02	2.4E-01	1.3E-01
	Antimony	mg/kg	1	17	7.8E-01	7.8E-01	7.8E-01	
	Arsenic	mg/kg	17	18	4.0E-01	1.4E+00	1.0E+01	5.8E+00
	Barium	mg/kg	18	18	1.6E+01	4.8E+01	3.0E+02	1.8E+02
	Beryllium	mg/kg	15	17	8.0E-02	3.4E-01	6.0E-01	6.5E-01
	Boron	mg/kg	7	17	1.0E+00	2.7E+00	3.7E+00	4.6E+00
	Cadmium	mg/kg	3	18	3.0E-01	7.7E-01	1.2E+00	1.7E+00
	Calcium	mg/kg	1	1	7.0E+03	7.0E+03	7.0E+03	
	Cesium-137	pCi/g	9	20	4.0E-02	1.2E-01	3.0E-01	2.8E-01

**TABLE C-5.—Sediment Detection Statistics by Watershed and Analyte
(Environmental Surveillance Report Data 1991 to 1996)-Continued**

WATERSHED ^a	ANALYTE	UNITS ^b	DETECTED	ANALYZED	MINIMUM	MEAN	MAXIMUM	95% UCL ^c
Sandia (cont.)	Chromium	mg/kg	18	18	2.5E+00	6.4E+00	1.2E+01	1.2E+01
	Cobalt	mg/kg	17	17	8.0E-01	2.5E+00	6.0E+00	5.2E+00
	Copper	mg/kg	15	17	1.6E+00	2.9E+00	5.6E+00	5.4E+00
	Di-n-butyl phthalate	µg/kg	1	1	4.4E+02	4.4E+02	4.4E+02	
	Gross Alpha	pCi/g	19	19	2.0E+00	2.7E+00	5.0E+00	4.3E+00
	Gross Beta	pCi/g	19	19	1.0E+00	1.7E+00	3.0E+00	3.0E+00
	Gross Gamma	pCi/g	20	20	1.0E+00	2.7E+00	1.0E+01	6.8E+00
	Iron	mg/kg	17	17	1.8E+03	5.7E+03	1.8E+04	1.5E+04
	Lead	mg/kg	17	18	3.0E+00	7.5E+00	1.3E+01	1.5E+01
	Lithium	mg/kg	1	1	3.1E+01	3.1E+01	3.1E+01	
	Magnesium	mg/kg	1	1	2.6E+03	2.6E+03	2.6E+03	
	Manganese	mg/kg	17	17	9.7E+01	2.0E+02	3.5E+02	3.9E+02
	Mercury	mg/kg	2	15	2.0E-02	2.0E-02	2.0E-02	2.0E-02
	Molybdenum	mg/kg	4	17	6.0E-01	1.3E+00	1.8E+00	2.2E+00
	Nickel	mg/kg	12	17	2.0E+00	4.4E+00	1.1E+01	1.1E+01
	Plutonium-238	pCi/g	17	20	1.0E-03	3.6E-03	1.3E-02	1.0E-02
	Plutonium-239, Plutonium-240	pCi/g	20	20	1.0E-03	2.6E-03	5.0E-03	5.3E-03
	Potassium	mg/kg	1	1	1.7E+03	1.7E+03	1.7E+03	
	Selenium	mg/kg	4	18	3.0E-01	4.3E-01	6.0E-01	7.3E-01
	Silver	mg/kg	5	18	2.0E+00	4.6E+00	8.0E+00	9.3E+00
	Sodium	mg/kg	1	1	2.6E+02	2.6E+02	2.6E+02	
	Strontium	mg/kg	17	17	2.6E+00	8.2E+00	2.9E+01	2.2E+01
	Strontium-90	pCi/g	10	18	1.0E-01	2.5E-01	8.0E-01	6.6E-01
Thallium	mg/kg	5	17	6.0E-02	3.6E+00	8.2E+00	1.1E+01	
Tin	mg/kg	7	17	4.0E+00	9.4E+00	1.8E+01	1.9E+01	

TABLE C-5.—Sediment Detection Statistics by Watershed and Analyte
(Environmental Surveillance Report Data 1991 to 1996)-Continued

WATERSHED ^a	ANALYTE	UNITS ^b	DETECTED	ANALYZED	MINIMUM	MEAN	MAXIMUM	95% UCL ^c
Sandia (cont.)	Tritium	nCi/l ^d	12	17	1.0E-01	1.1E+00	2.7E+00	2.9E+00
	Uranium	mg/kg	18	18	7.0E-01	1.7E+00	3.4E+00	3.0E+00
	Vanadium	mg/kg	17	17	2.7E+00	9.3E+00	4.3E+01	3.0E+01
	Zinc	mg/kg	17	17	1.8E+01	3.2E+01	7.7E+01	6.9E+01
	Aluminum	mg/kg	10	10	6.6E+02	6.3E+03	2.1E+04	1.9E+04
	Americium-241	pCi/g	10	10	1.0E-03	1.4E-02	1.1E-01	7.9E-02
	Arsenic	mg/kg	10	11	4.0E-01	1.2E+00	2.4E+00	2.8E+00
	Barium	mg/kg	11	11	1.4E+01	9.6E+01	2.5E+02	2.8E+02
	Beryllium	mg/kg	8	10	1.7E-01	5.6E-01	1.3E+00	1.3E+00
	Boron	mg/kg	5	10	2.5E+00	8.1E+00	2.5E+01	2.7E+01
Water	Cadmium	mg/kg	3	11	3.6E-01	5.4E-01	7.0E-01	8.9E-01
	Calcium	mg/kg	1	1	3.7E+03	3.7E+03	3.7E+03	
	Cesium-137	pCi/g	11	13	8.0E-02	2.4E-01	7.0E-01	6.3E-01
	Chromium	mg/kg	11	11	2.0E+00	4.5E+00	1.2E+01	1.2E+01
	Cobalt	mg/kg	9	10	1.5E+00	3.2E+00	6.5E+00	7.5E+00
	Copper	mg/kg	8	10	9.7E-01	4.8E+00	1.2E+01	1.3E+01
	Di-n-butyl phthalate	µg/kg	1	1	3.8E+02	3.8E+02	3.8E+02	
	Gross Alpha	pCi/g	13	13	2.0E+00	3.7E+00	8.7E+00	8.4E+00
	Gross Beta	pCi/g	13	13	1.0E+00	2.9E+00	7.0E+00	7.1E+00
	Gross Gamma	pCi/g	12	13	1.5E+00	3.7E+00	9.0E+00	7.7E+00
	Iron	mg/kg	10	10	1.5E+03	6.7E+03	1.6E+04	1.6E+04
	Lead	mg/kg	10	11	1.5E+00	9.3E+00	1.7E+01	1.9E+01
	Lithium	mg/kg	1	1	1.3E+01	1.3E+01	1.3E+01	
	Magnesium	mg/kg	1	1	2.5E+03	2.5E+03	2.5E+03	
	Manganese	mg/kg	10	10	4.3E+01	2.0E+02	3.9E+02	4.3E+02

**TABLE C-5.—Sediment Detection Statistics by Watershed and Analyte
(Environmental Surveillance Report Data 1991 to 1996)-Continued**

WATERSHED ^a	ANALYTE	UNITS ^b	DETECTED	ANALYZED	MINIMUM	MEAN	MAXIMUM	95% UCL ^c
Water (cont.)	Mercury	mg/kg	5	11	1.0E-02	2.4E-02	4.0E-02	4.7E-02
	Molybdenum	mg/kg	1	10	1.8E+00	1.8E+00	1.8E+00	
	Nickel	mg/kg	7	10	1.9E+00	5.8E+00	1.1E+01	1.2E+01
	Plutonium-238	pCi/g	10	13	1.0E-03	2.1E-03	7.0E-03	6.1E-03
	Plutonium-239, Plutonium-240	pCi/g	13	13	2.0E-03	6.4E-03	1.4E-02	1.4E-02
	Potassium	mg/kg	1	1	2.5E+03	2.5E+03	2.5E+03	
	Selenium	mg/kg	2	11	4.0E-01	4.5E-01	5.0E-01	5.9E-01
	Silver	mg/kg	1	11	1.7E+00	1.7E+00	1.7E+00	
	Sodium	mg/kg	1	1	2.9E+02	2.9E+02	2.9E+02	
	Strontium	mg/kg	10	10	2.9E+00	2.2E+01	9.5E+01	7.8E+01
	Strontium-90	pCi/g	10	12	1.0E-01	1.7E-01	4.0E-01	3.8E-01
	Thallium	mg/kg	1	10	4.0E-02	4.0E-02	4.0E-02	
	Tin	mg/kg	2	10	6.0E+00	8.0E+00	1.0E+01	1.4E+01
	Tritium	nCi/l ^d	6	9	4.7E-02	2.6E+00	1.5E+01	1.4E+01
	Uranium	mg/kg	13	13	6.5E-01	1.7E+00	2.9E+00	2.9E+00
	Vanadium	mg/kg	10	10	3.2E+00	8.3E+00	2.4E+01	2.2E+01
	Zinc	mg/kg	10	10	1.4E+01	2.9E+01	4.7E+01	5.4E+01

^a Watershed includes both on-site and perimeter analyses as designated by the Environmental Surveillance Program.

^b pCi/g is picocuries of radioactive analyte per gram of sample, nCi/l is nanocuries of radioactive analyte per liter of sample, µg/kg is micrograms of analyte per kilogram of sample, mg/kg is milligrams of analyte per kilogram of sample.

^c Upper confidence limit (UCL) not calculated when the number of detected analyses equals 1.

^d Tritium is reported as nanocuries of tritium per liter (nCi/l) of water because tritium in sediments exists as tritiated water. The water is distilled, and the tritium content of the water is measured.

TABLE C-6.—Groundwater Detection Statistics by Regime and Analyte
(Environmental Surveillance Report Data 1991 to 1996)

GROUNDWATER REGIME ^a	ANALYTE	UNITS ^b	DETECTED	ANALYZED	MINIMUM	MEAN	MAXIMUM	95% UCL ^c
Alluvial Groundwater Wells	Acetone	µg/l	5	40	2.0E+00	7.4E+00	2.1E+01	2.3E+01
	Actinium-228	pCi/l	3	6	1.2E+00	6.2E+00	9.8E+00	1.5E+01
	Aluminum	µg/l	161	174	2.5E+01	9.8E+03	2.4E+05	6.7E+04
	Americium-241	pCi/l	166	201	9.0E-04	2.9E+00	9.4E+01	2.6E+01
	Ammonia, as Nitrogen	mg/l	4	11	3.0E-02	1.0E-01	2.4E-01	2.9E-01
	Antimony	µg/l	22	171	2.0E-01	1.4E+00	3.0E+00	2.9E+00
	Arsenic	µg/l	77	172	1.0E+00	9.2E+00	8.3E+01	3.9E+01
	Barium	µg/l	139	159	3.0E-02	2.6E+02	3.1E+03	1.3E+03
	Barium-140	pCi/l	17	23	6.7E-01	7.0E+00	1.9E+01	1.6E+01
	Benzidine [m-]	µg/l	1	27	2.0E+01	2.0E+01	2.0E+01	2.0E+01
	Beryllium	µg/l	36	171	3.0E-01	6.0E+00	3.0E+01	2.0E+01
	Bicarbonate	mg/l	145	146	2.6E+01	1.1E+02	3.2E+02	2.2E+02
	Bis(2-ethylhexyl) phthalate	µg/l	2	38	4.0E+00	6.0E+00	8.0E+00	1.2E+01
	Bismuth-211	pCi/l	2	6	3.3E+01	4.1E+01	4.8E+01	6.1E+01
	Bismuth-212	pCi/l	5	6	2.2E+01	3.8E+01	7.6E+01	8.5E+01
	Bismuth-214	pCi/l	1	6	8.3E+00	8.3E+00	8.3E+00	8.3E+00
	Boron	µg/l	134	181	1.3E+01	8.0E+01	5.0E+02	2.3E+02
	Cadmium	µg/l	23	173	2.0E-01	4.7E+00	3.6E+01	2.1E+01
	Cadmium-109	pCi/l	5	6	2.5E+01	4.0E+01	5.7E+01	6.9E+01
	Calcium	mg/l	174	174	6.0E+00	2.7E+01	3.2E+02	8.8E+01
Carbonate	mg/l	2	147	1.0E+00	2.0E+00	3.0E+00	4.8E+00	
Cerium-139	pCi/l	2	6	5.5E-02	2.8E-01	5.0E-01	9.1E-01	

TABLE C-6.—Groundwater Detection Statistics by Regime and Analyte
(Environmental Surveillance Report Data 1991 to 1996)-Continued

GROUNDWATER REGIME ^a	ANALYTE	UNITS ^b	DETECTED	ANALYZED	MINIMUM	MEAN	MAXIMUM	95% UCL ^c
Alluvial Groundwater Wells (cont.)	Cerium-144	pCi/l	33	51	2.8E-01	3.3E+01	1.6E+02	1.2E+02
	Cesium-134	pCi/l	1	6	2.4E-01	2.4E-01	2.4E-01	
	Cesium-137	pCi/l	103	165	1.3E-02	1.4E+01	2.6E+02	1.0E+02
	Chlorine	mg/l	150	150	6.0E+00	3.6E+01	4.5E+02	1.2E+02
	Chloro-3-methylphenol [4-]	µg/l	1	38	2.0E+01	2.0E+01	2.0E+01	
	Chloromethane	µg/l	1	40	1.1E+01	1.1E+01	1.1E+01	
	Chlorophenol [o-]	µg/l	1	38	1.0E+01	1.0E+01	1.0E+01	
	Chromium	µg/l	67	171	1.1E+00	4.4E+02	7.7E+03	3.5E+03
	Cobalt	µg/l	29	174	3.1E+00	1.6E+01	7.1E+01	5.0E+01
	Cobalt-57	pCi/l	23	34	1.4E-01	4.7E+00	1.8E+01	1.5E+01
	Cobalt-60	pCi/l	45	51	1.4E-01	1.1E+01	4.6E+01	3.6E+01
	Copper	µg/l	63	174	1.3E+00	3.8E+01	8.7E+02	2.6E+02
	Cyanide	mg/l	15	138	1.0E-02	2.6E-02	6.0E-02	5.6E-02
	Dichlorophenol [2,4-]	µg/l	1	38	1.0E+01	1.0E+01	1.0E+01	
	Dimethylphenol [2,4-]	µg/l	1	38	1.0E+01	1.0E+01	1.0E+01	
	Di-n-butyl phthalate	µg/l	2	38	1.1E+01	1.2E+01	1.2E+01	1.3E+01
	Dinitrophenol [2,4-]	µg/l	1	38	5.0E+01	5.0E+01	5.0E+01	
	Europium-152	pCi/l	40	51	9.8E-01	2.9E+01	1.2E+02	1.0E+02
	Fluorine	mg/l	161	169	1.0E-01	9.3E-01	2.2E+00	2.1E+00
	Gross Alpha	pCi/l	134	166	2.0E-01	1.2E+01	1.4E+02	6.0E+01
Gross Beta	pCi/l	164	166	2.0E+00	7.3E+01	6.3E+02	3.0E+02	
Gross Gamma	pCi/l	135	160	2.0E+00	1.2E+02	9.0E+02	3.8E+02	

TABLE C-6.—Groundwater Detection Statistics by Regime and Analyte
(Environmental Surveillance Report Data 1991 to 1996)-Continued

GROUNDWATER REGIME ^a	ANALYTE	UNITS ^b	DETECTED	ANALYZED	MINIMUM	MEAN	MAXIMUM	95% UCL ^c
Alluvial Groundwater Wells (cont.)	Hardness	mg/l	125	125	2.0E+01	1.0E+02	1.1E+03	3.7E+02
	Iodine-129	pCi/l	2	7	7.7E-01	1.9E+00	3.1E+00	5.3E+00
	Iron	µg/l	161	174	4.0E+01	7.5E+03	1.9E+05	5.4E+04
	Lanthanum-140	pCi/l	1	6	3.8E+02	3.8E+02	3.8E+02	
	Lead	µg/l	68	176	6.0E-01	3.2E+01	4.1E+02	1.6E+02
	Lead-210	pCi/l	4	6	1.5E+02	1.0E+03	1.7E+03	2.3E+03
	Lead-211	pCi/l	3	6	1.8E+00	1.2E+01	2.6E+01	3.7E+01
	Lead-212	pCi/l	3	6	1.2E-01	3.8E+00	6.2E+00	1.0E+01
	Lead-214	pCi/l	2	6	5.0E+00	7.9E+00	1.1E+01	1.6E+01
	Lithium	mg/l	63	94	1.0E-03	3.1E-02	1.3E-01	8.2E-02
	Magnesium	mg/l	154	174	1.4E+00	6.1E+00	7.7E+01	2.1E+01
	Manganese	µg/l	127	174	7.0E-01	8.4E+02	1.4E+04	5.5E+03
	Manganese-54	pCi/l	2	6	5.2E-01	5.2E-01	5.3E-01	5.3E-01
	Mercury	µg/l	41	173	3.0E-02	9.5E-01	1.4E+01	6.0E+00
	Mercury-203	pCi/l	6	6	9.9E-02	1.7E+00	3.2E+00	4.1E+00
	Methyl-4,6-dinitrophenol [2-]	µg/l	1	38	5.0E+01	5.0E+01	5.0E+01	
	Methylphenol [2-]	µg/l	1	38	1.0E+01	1.0E+01	1.0E+01	
	Methylphenol [4-]	µg/l	1	38	1.0E+01	1.0E+01	1.0E+01	
	Molybdenum	µg/l	114	175	2.0E-01	1.9E+02	1.0E+03	6.6E+02
	Neptunium-237	pCi/l	32	51	4.9E-02	2.5E+01	1.1E+02	9.1E+01
	Nickel	µg/l	39	174	1.1E+00	3.1E+01	1.7E+02	1.0E+02
	Nitrate, as Nitrogen	mg/l	156	184	4.0E-02	1.2E+01	6.6E+01	4.5E+01
	Nitrite, as Nitrogen	mg/l	4	11	2.0E-02	4.5E-02	9.0E-02	1.1E-01
Nitrophenol [2-]	µg/l	1	38	1.0E+01	1.0E+01	1.0E+01		

TABLE C-6.—Groundwater Detection Statistics by Regime and Analyte
(Environmental Surveillance Report Data 1991 to 1996)-Continued

GROUNDWATER REGIME ^a	ANALYTE	UNITS ^b	DETECTED	ANALYZED	MINIMUM	MEAN	MAXIMUM	95% UCL ^c
Alluvial Groundwater Wells (cont.)	Nitrophenol [4-]	µg/l	1	38	5.0E+01	5.0E+01	5.0E+01	
	Pentachlorophenol	µg/l	2	38	1.1E+01	3.1E+01	5.0E+01	8.6E+01
	pH		150	150	1.0E-01		9.0E+00	
	Phenol	µg/l	1	38	1.0E+01	1.0E+01	1.0E+01	
	Phosphate, as Phosphorous	mg/l	122	129	2.0E-02	7.4E-01	2.9E+01	6.2E+00
	Phosphorous	mg/l	17	29	4.3E-02	6.7E-01	4.8E+00	3.8E+00
	Plutonium-238	pCi/l	117	167	1.0E-03	7.5E-02	2.4E+00	6.3E-01
	Plutonium-239, Plutonium-240	pCi/l	149	167	1.0E-03	1.7E-01	7.6E+00	1.8E+00
	Potassium	mg/l	165	171	1.0E+00	1.2E+01	3.6E+01	2.8E+01
	Potassium-40	pCi/l	24	34	2.2E+00	2.9E+02	1.3E+03	9.3E+02
	Protactinium-231	pCi/l	4	6	6.5E+00	1.0E+01	1.5E+01	1.8E+01
	Protactinium-233	pCi/l	3	6	1.5E-01	6.6E-01	1.3E+00	1.8E+00
	Protactinium-234M	pCi/l	5	6	2.9E+01	2.5E+02	5.0E+02	6.2E+02
	Pyridine	µg/l	2	5	1.0E+01	1.0E+01	1.0E+01	1.0E+01
	Radium-223	pCi/l	2	6	2.8E+00	5.5E+00	8.3E+00	1.3E+01
	Radium-224	pCi/l	1	6	3.2E+01	3.2E+01	3.2E+01	
	Radium-226	pCi/l	5	6	2.5E+01	9.4E+01	1.8E+02	2.2E+02
	Radon-219	pCi/l	2	6	5.9E-01	5.8E+00	1.1E+01	2.1E+01
	Ruthenium-106	pCi/l	23	51	2.1E+00	3.2E+01	1.5E+02	1.0E+02
	Selenium	µg/l	30	172	1.0E+00	1.8E+01	9.0E+01	7.6E+01
	Selenium-75	pCi/l	3	6	3.3E-01	9.6E-01	1.8E+00	2.5E+00
	Silica	mg/l	148	148	2.0E+01	4.2E+01	1.6E+02	7.4E+01
	Silver	µg/l	19	173	3.0E-01	1.6E+01	1.7E+02	9.2E+01

TABLE C-6.—Groundwater Detection Statistics by Regime and Analyte
(Environmental Surveillance Report Data 1991 to 1996)-Continued

GROUNDWATER REGIME ^a	ANALYTE	UNITS ^b	DETECTED	ANALYZED	MINIMUM	MEAN	MAXIMUM	95% UCL ^c
Alluvial Groundwater Wells (cont.)	Sodium	mg/l	174	174	4.0E+00	5.6E+01	1.6E+02	1.2E+02
	Sodium-22	pCi/l	38	51	2.9E-02	7.5E+00	3.3E+01	2.3E+01
	Strontium	µg/l	175	175	4.8E+01	1.6E+02	1.5E+03	4.4E+02
	Strontium-85	pCi/l	2	6	3.5E+00	3.5E+00	3.5E+00	3.6E+00
	Strontium-90	pCi/l	141	151	1.0E-01	2.2E+01	3.7E+02	1.0E+02
	Sulfate	mg/l	172	172	2.0E+00	1.5E+01	1.5E+02	4.5E+01
	Thallium	µg/l	27	170	4.0E-02	1.3E+00	6.0E+00	4.0E+00
	Thallium-208	pCi/l	3	6	9.4E-02	3.3E+00	6.8E+00	1.0E+01
	Thorium-227	pCi/l	3	6	5.8E+00	8.7E+00	1.3E+01	1.7E+01
	Thorium-234	pCi/l	2	6	6.0E+00	1.6E+02	3.1E+02	5.8E+02
	Tin	µg/l	10	160	1.0E+01	3.3E+01	7.0E+01	7.0E+01
	Tin-113	pCi/l	3	6	6.7E-01	1.1E+00	1.6E+00	2.0E+00
	Total Dissolved Solids	mg/l	152	152	1.1E+01	3.1E+02	1.4E+03	6.7E+02
	Total Kjeldahl Nitrogen	mg/l	9	11	4.0E-02	6.8E-01	2.5E+00	2.2E+00
	Total Suspended Solids	mg/l	32	59	1.0E+00	8.6E+01	8.6E+02	4.5E+02
	Trichlorobenzene [1,2,4-]	µg/l	1	44	5.0E+00	5.0E+00	5.0E+00	
	Trichlorophenol [2,4,5-]	µg/l	1	38	5.0E+01	5.0E+01	5.0E+01	
	Trichlorophenol [2,4,6-]	µg/l	1	38	1.0E+01	1.0E+01	1.0E+01	
	Tritium	nCi/l	145	167	2.9E-02	1.2E+01	1.1E+02	4.9E+01
	Turbidity	NTU	27	27	3.5E-01	6.2E+00	8.0E+01	3.7E+01
Uranium	µg/l	150	167	2.0E-02	2.0E+00	5.0E+01	1.1E+01	

TABLE C-6.—Groundwater Detection Statistics by Regime and Analyte
(Environmental Surveillance Report Data 1991 to 1996)-Continued

GROUNDWATER REGIME ^a	ANALYTE	UNITS ^b	DETECTED	ANALYZED	MINIMUM	MEAN	MAXIMUM	95% UCL ^c
Alluvial Groundwater Wells (cont.)	Vanadium	µg/l	64	171	1.7E+00	3.1E+01	3.5E+02	1.3E+02
	Yttrium-88	pCi/l	3	6	1.0E+00	1.7E+00	2.3E+00	3.0E+00
	Zinc	µg/l	96	174	9.0E-02	9.2E+01	1.6E+03	4.7E+02
	Zinc-65	pCi/l	5	6	7.8E-01	1.2E+00	1.6E+00	2.0E+00
	Bicarbonate	mg/l	1	1	5.7E+01	5.7E+01	5.7E+01	
	Calcium	mg/l	1	1	1.1E+01	1.1E+01	1.1E+01	
	Chlorine	mg/l	1	1	6.3E+00	6.3E+00	6.3E+00	
	Fluorine	mg/l	1	1	1.5E-01	1.5E-01	1.5E-01	
	Hardness	mg/l	1	1	4.3E+01	4.3E+01	4.3E+01	
	Magnesium	mg/l	1	1	3.9E+00	3.9E+00	3.9E+00	
Springs (Threemile Spring)	pH		1	1	6.6E+00		6.6E+00	
	Phosphate, as Phosphorous	mg/l	1	1	4.0E-02	4.0E-02	4.0E-02	
	Potassium	mg/l	1	1	3.2E+00	3.2E+00	3.2E+00	
	Silica	mg/l	1	1	3.5E+01	3.5E+01	3.5E+01	
	Sodium	mg/l	1	1	1.0E+01	1.0E+01	1.0E+01	
	Sulfate	mg/l	1	1	5.1E+00	5.1E+00	5.1E+00	
	Total Dissolved Solids	mg/l	1	1	1.5E+02	1.5E+02	1.5E+02	
	Aluminum	µg/l	4	13	4.0E+01	3.9E+03	1.5E+04	1.9E+04
	Americium-241	pCi/l	6	8	1.1E-02	4.8E-02	1.1E-01	1.3E-01
	Antimony	µg/l	3	13	1.0E-01	4.5E+01	1.3E+02	2.0E+02
Intermediate Perched Groundwater Wells	Arsenic	µg/l	5	13	2.0E+00	4.7E+00	7.0E+00	9.0E+00
	Barium	µg/l	9	11	3.0E+01	6.1E+01	1.7E+02	1.5E+02
	Beryllium	µg/l	1	13	3.0E+00	3.0E+00	3.0E+00	
	Bicarbonate	mg/l	13	13	5.3E+01	9.7E+01	1.6E+02	1.6E+02

TABLE C-6.—Groundwater Detection Statistics by Regime and Analyte
(Environmental Surveillance Report Data 1991 to 1996)-Continued

GROUNDWATER REGIME ^a	ANALYTE	UNITS ^b	DETECTED	ANALYZED	MINIMUM	MEAN	MAXIMUM	95% UCL ^c
Intermediate Perched Groundwater Wells (cont.)	Boron	µg/l	12	13	3.0E+01	1.4E+02	2.3E+02	2.8E+02
	Cadmium	µg/l	4	13	4.0E-01	5.7E+00	1.0E+01	1.4E+01
	Calcium	mg/l	13	13	1.0E+01	2.8E+01	3.8E+01	4.6E+01
	Cesium-137	pCi/l	8	13	3.2E-01	1.0E+01	5.6E+01	4.9E+01
	Chlorine	mg/l	13	13	4.6E+00	3.9E+01	6.1E+01	7.2E+01
	Chromium	µg/l	2	13	1.6E+00	4.0E+00	6.4E+00	1.1E+01
	Cobalt	µg/l	1	13	9.0E+00	9.0E+00	9.0E+00	
	Copper	µg/l	5	13	8.0E+00	3.2E+01	5.5E+01	7.0E+01
	Fluorine	mg/l	13	13	2.0E-01	4.7E-01	9.0E-01	1.0E+00
	Gross Alpha	pCi/l	5	13	1.0E+00	1.8E+00	3.0E+00	3.5E+00
	Gross Beta	pCi/l	13	13	1.2E+00	8.8E+00	5.2E+01	3.5E+01
	Gross Gamma	pCi/l	10	13	1.0E+01	9.5E+01	2.4E+02	2.3E+02
	Hardness	mg/l	13	13	3.3E+01	9.5E+01	1.2E+02	1.6E+02
	Iron	µg/l	13	13	4.5E+02	8.1E+03	5.7E+04	3.9E+04
	Lead	µg/l	11	15	4.6E+00	3.5E+01	9.1E+01	1.1E+02
	Lithium	mg/l	2	2	1.3E-02	2.4E-02	3.5E-02	5.5E-02
	Magnesium	mg/l	13	13	1.8E+00	6.6E+00	8.6E+00	1.0E+01
	Manganese	µg/l	13	13	5.6E+01	1.6E+02	6.8E+02	4.8E+02
	Mercury	µg/l	3	13	2.0E-01	3.7E-01	7.0E-01	9.4E-01
	Molybdenum	µg/l	6	13	5.0E+00	1.8E+01	6.2E+01	6.2E+01
	Nickel	µg/l	2	13	2.0E+01	3.1E+01	4.1E+01	6.0E+01
	Nitrate, as Nitrogen	mg/l	11	13	9.0E-02	5.5E+00	1.9E+01	1.8E+01
	pH		9	9	6.9E+00		8.6E+00	
Phosphate, as Phosphorous	mg/l	10	11	1.0E-01	1.1E+00	4.1E+00	3.9E+00	

TABLE C-6.—Groundwater Detection Statistics by Regime and Analyte
(Environmental Surveillance Report Data 1991 to 1996)-Continued

GROUNDWATER REGIME ^a	ANALYTE	UNITS ^b	DETECTED	ANALYZED	MINIMUM	MEAN	MAXIMUM	95% UCL ^c
Intermediate Perched Groundwater Wells (cont.)	Plutonium-238	pCi/l	6	16	3.0E-03	1.2E-02	3.0E-02	3.3E-02
	Plutonium-239, Plutonium-240	pCi/l	10	16	7.0E-03	1.5E-01	1.3E+00	9.5E-01
	Potassium	mg/l	12	13	1.6E+00	5.1E+00	9.6E+00	9.8E+00
	Selenium	µg/l	1	13	2.0E+00	2.0E+00	2.0E+00	
	Silica	mg/l	12	13	7.0E+00	4.2E+01	6.8E+01	8.1E+01
	Sodium	mg/l	13	13	1.8E+01	4.3E+01	8.8E+01	8.4E+01
	Strontium	µg/l	12	13	3.3E+01	1.5E+02	2.1E+02	2.6E+02
	Strontium-90	pCi/l	6	9	1.0E-01	3.9E+00	2.1E+01	2.0E+01
	Sulfate	mg/l	12	13	7.3E+00	2.1E+01	3.1E+01	3.7E+01
	Thallium	µg/l	2	13	1.0E-01	6.0E-01	1.1E+00	2.0E+00
	Tin	µg/l	1	11	7.0E+01	7.0E+01	7.0E+01	
	Total Dissolved Solids	mg/l	11	13	1.8E+02	2.6E+02	3.3E+02	3.6E+02
	Total Suspended Solids	mg/l	2	4	7.6E+00	9.3E+00	1.1E+01	1.4E+01
	Tritium	nCi/l	13	13	1.8E-01	1.3E+00	3.1E+00	3.7E+00
	Uranium	µg/l	11	13	8.0E-02	6.4E-01	3.3E+00	2.5E+00
	Vanadium	µg/l	4	13	2.0E+00	1.2E+01	3.0E+01	3.7E+01
	Zinc	µg/l	12	13	8.2E+01	2.7E+03	9.5E+03	9.0E+03
	Aluminum	µg/l	5	6	6.0E+01	6.5E+02	2.3E+03	2.5E+03
	Americium-241	pCi/l	2	5	3.0E-02	3.4E-02	3.8E-02	4.5E-02
Antimony	µg/l	4	6	4.0E-01	7.5E-01	1.0E+00	1.4E+00	
Arsenic	µg/l	5	6	3.0E+00	6.0E+00	1.3E+01	1.4E+01	
Barium	µg/l	5	5	4.8E+01	7.3E+01	1.1E+02	1.2E+02	
Bicarbonate	mg/l	6	6	5.3E+01	9.7E+01	1.2E+02	1.5E+02	
Spring from Basalt (Basalt Spring)								

TABLE C-6.—Groundwater Detection Statistics by Regime and Analyte
(Environmental Surveillance Report Data 1991 to 1996)-Continued

GROUNDWATER REGIME ^a	ANALYTE	UNITS ^b	DETECTED	ANALYZED	MINIMUM	MEAN	MAXIMUM	95% UCL ^c
Spring from Basalt (Basalt Spring) (cont.)	Boron	µg/l	6	6	8.0E+01	1.7E+02	2.7E+02	3.5E+02
	Bromine	µg/l	1	1	8.0E+01	8.0E+01	8.0E+01	8.0E+01
	Calcium	mg/l	6	6	1.2E+01	2.6E+01	3.7E+01	4.4E+01
	Cesium-137	pCi/l	4	6	1.2E+00	4.9E+00	1.3E+01	1.6E+01
	Chlorine	mg/l	6	6	2.1E+01	3.2E+01	4.5E+01	5.0E+01
	Chloroethane	µg/l	1	2	2.1E+01	2.1E+01	2.1E+01	2.1E+01
	Chromium	µg/l	3	6	1.5E+00	3.2E+00	5.0E+00	6.7E+00
	Cobalt	µg/l	1	6	1.5E+01	1.5E+01	1.5E+01	1.5E+01
	Copper	µg/l	4	6	3.0E+00	9.3E+00	1.7E+01	2.3E+01
	Cyanide	mg/l	1	4	2.3E-02	2.3E-02	2.3E-02	2.3E-02
	Fluorine	mg/l	6	6	3.0E-01	4.7E-01	8.0E-01	8.2E-01
	Gross Alpha	pCi/l	4	6	1.0E+00	2.4E+00	4.0E+00	5.6E+00
	Gross Beta	pCi/l	6	6	5.0E+00	8.2E+00	1.3E+01	1.4E+01
	Gross Gamma	pCi/l	5	6	2.0E+01	6.4E+01	1.9E+02	2.1E+02
	Hardness	mg/l	6	6	4.3E+01	8.7E+01	1.3E+02	1.5E+02
	Iron	µg/l	6	6	3.0E+01	3.9E+02	1.5E+03	1.5E+03
	Lead	µg/l	4	7	1.0E+00	2.3E+00	5.2E+00	6.3E+00
	Magnesium	mg/l	6	6	3.1E+00	6.2E+00	9.4E+00	1.1E+01
	Manganese	µg/l	5	6	1.7E+01	1.8E+02	6.4E+02	7.0E+02
	Mercury	µg/l	3	6	1.0E-01	4.3E-01	8.0E-01	1.1E+00
Molybdenum	µg/l	4	6	3.0E+00	2.2E+01	6.9E+01	8.5E+01	
Nickel	µg/l	1	6	3.4E+01	3.4E+01	3.4E+01	3.4E+01	
Nitrate, as Nitrogen	mg/l	7	7	1.3E+00	5.3E+00	1.5E+01	1.6E+01	
Nitrite, as Nitrogen	mg/l	1	1	9.2E-01	9.2E-01	9.2E-01	9.2E-01	
pH			6	6	6.7E+00		8.3E+00	

TABLE C-6.—Groundwater Detection Statistics by Regime and Analyte
(Environmental Surveillance Report Data 1991 to 1996)-Continued

GROUNDWATER REGIME ^a	ANALYTE	UNITS ^b	DETECTED	ANALYZED	MINIMUM	MEAN	MAXIMUM	95% UCL ^c
Spring from Basalt (Basalt Spring) (cont.)	Phosphate	mg/l	1	1	5.7E+00	5.7E+00	5.7E+00	
	Phosphate, as Phosphorous	mg/l	5	5	2.0E-01	3.0E+00	6.9E+00	8.3E+00
	Plutonium-238	pCi/l	3	6	1.2E-02	1.3E-02	1.4E-02	1.5E-02
	Plutonium-239, Plutonium-240	pCi/l	5	6	1.4E-02	5.5E-02	1.4E-01	1.6E-01
	Potassium	mg/l	5	5	4.0E+00	8.1E+00	1.2E+01	1.5E+01
	Silica	mg/l	7	7	5.0E+01	6.1E+01	8.1E+01	8.5E+01
	Silver	µg/l	1	6	1.0E+00	1.0E+00	1.0E+00	
	Sodium	mg/l	6	6	2.7E+01	4.2E+01	6.7E+01	7.4E+01
	Strontium	µg/l	6	6	6.0E+01	1.4E+02	2.0E+02	2.5E+02
	Strontium-90	pCi/l	4	5	4.0E-01	5.0E-01	7.0E-01	7.8E-01
	Sulfate	mg/l	6	6	8.7E+00	2.1E+01	3.4E+01	3.7E+01
	Thallium	µg/l	2	6	4.0E-02	2.2E-01	4.0E-01	7.3E-01
	Total Dissolved Solids	mg/l	6	6	2.5E+02	3.2E+02	3.8E+02	4.1E+02
	Total Suspended Solids	mg/l	2	2	3.7E+00	1.7E+01	3.0E+01	5.4E+01
	Tritium	nCi/l	5	6	2.0E-01	4.2E-01	8.0E-01	9.6E-01
	Uranium	µg/l	6	6	5.9E-01	1.0E+00	2.1E+00	2.2E+00
	Vanadium	µg/l	6	6	7.0E+00	1.2E+01	1.9E+01	2.2E+01
	Zinc	µg/l	3	6	1.0E+01	2.1E+01	3.0E+01	4.1E+01

TABLE C-6.—Groundwater Detection Statistics by Regime and Analyte
(Environmental Surveillance Report Data 1991 to 1996)-Continued

GROUNDWATER REGIME ^a	ANALYTE	UNITS ^b	DETECTED	ANALYZED	MINIMUM	MEAN	MAXIMUM	95% UCL ^c
Main Aquifer Supply Wells	Acetone	µg/l	1	2	4.1E+01	4.1E+01	4.1E+01	
	Aluminum	µg/l	12	79	3.0E+01	3.5E+02	1.9E+03	1.4E+03
	Americium-241	pCi/l	40	53	2.0E-03	3.5E-02	1.1E-01	8.4E-02
	Antimony	µg/l	14	79	3.0E-01	1.4E+00	4.0E+00	3.3E+00
	Arsenic	µg/l	48	79	2.0E+00	1.3E+01	4.8E+01	4.1E+01
	Barium	µg/l	57	64	3.0E+00	4.9E+01	2.9E+02	1.5E+02
	Beryllium	µg/l	6	79	1.0E+00	1.3E+00	2.0E+00	2.4E+00
	Bicarbonate	mg/l	78	78	4.7E+01	1.1E+02	3.0E+02	2.2E+02
	Boron	µg/l	57	79	8.0E+00	8.1E+01	5.0E+02	2.9E+02
	Bromine	µg/l	2	2	1.0E+02	1.1E+02	1.1E+02	1.2E+02
	Cadmium	µg/l	4	79	1.8E+00	3.6E+00	5.0E+00	6.3E+00
	Calcium	mg/l	79	79	2.0E+00	1.5E+01	3.2E+01	2.9E+01
	Carbonate	mg/l	12	78	2.0E+00	1.2E+01	3.5E+01	3.1E+01
	Cesium-137	pCi/l	38	71	2.0E-02	5.9E+01	4.3E+02	2.7E+02
	Chlorine	mg/l	74	75	2.0E+00	5.7E+00	2.1E+01	1.5E+01
	Chloroethane	µg/l	1	2	1.3E+01	1.3E+01	1.3E+01	
	Chromium	µg/l	47	79	2.0E+00	1.2E+01	3.9E+01	2.9E+01
	Cobalt	µg/l	2	77	3.0E+00	6.7E+01	1.3E+02	2.5E+02
	Copper	µg/l	36	79	1.0E+00	1.7E+01	8.3E+01	5.3E+01
	Cyanide	mg/l	2	63	1.0E-02	1.0E-02	1.0E-02	1.0E-02
	Fluorine	mg/l	78	78	2.0E-01	1.6E+00	4.9E+01	1.4E+01
Gross Alpha	pCi/l	49	74	2.0E-01	2.8E+00	3.0E+01	1.2E+01	
Gross Beta	pCi/l	74	74	7.0E-01	3.7E+00	9.0E+00	7.4E+00	
Gross Gamma	pCi/l	43	69	1.0E+01	1.3E+02	5.5E+02	3.7E+02	
Hardness	mg/l	79	79	5.0E+00	4.7E+01	1.2E+02	9.9E+01	
Iron	µg/l	28	79	1.0E+01	2.6E+03	2.9E+04	1.7E+04	

TABLE C-6.—Groundwater Detection Statistics by Regime and Analyte
(Environmental Surveillance Report Data 1991 to 1996)-Continued

GROUNDWATER REGIME ^a	ANALYTE	UNITS ^b	DETECTED	ANALYZED	MINIMUM	MEAN	MAXIMUM	95% UCL ^c
Main Aquifer	Lead	µg/l	25	84	1.0E+00	1.2E+01	9.5E+01	5.3E+01
	Lithium	mg/l	11	11	2.4E-02	4.4E-02	1.1E-01	9.7E-02
Supply Wells (cont.)	Magnesium	mg/l	68	79	4.2E-02	2.9E+00	9.4E+00	8.2E+00
	Manganese	µg/l	28	79	1.0E+00	4.2E+01	2.7E+02	1.8E+02
	Mercury	µg/l	8	68	1.0E-01	1.5E-01	2.0E-01	2.6E-01
	Molybdenum	µg/l	27	79	1.0E+00	7.0E+00	3.0E+01	2.3E+01
	Nickel	µg/l	5	79	5.0E+00	1.5E+01	2.3E+01	3.0E+01
	Nitrate, as Nitrogen	mg/l	81	85	4.5E-03	8.0E-01	9.9E+00	3.4E+00
	pH		78	78	7.2E+00		9.4E+00	
	Phosphate, as Phosphorous	mg/l	30	79	2.0E-02	1.3E-01	3.0E-01	3.4E-01
	Plutonium-238	pCi/l	44	82	1.0E-04	1.2E-02	4.7E-02	3.1E-02
	Plutonium-239, Plutonium-240	pCi/l	59	82	1.0E-04	3.2E-02	6.7E-01	2.1E-01
	Potassium	mg/l	65	79	4.6E-01	2.5E+00	4.4E+00	4.0E+00
	Selenium	µg/l	14	79	1.7E+00	4.3E+00	1.2E+01	1.1E+01
	Silica	mg/l	78	80	9.3E+00	6.3E+01	1.2E+02	1.2E+02
	Silver	µg/l	11	78	2.0E+00	3.6E+01	5.8E+01	7.9E+01
	Sodium	mg/l	79	79	1.0E+01	3.5E+01	1.9E+02	1.1E+02
	Strontium	µg/l	75	79	1.0E+01	1.2E+02	8.3E+02	3.8E+02
	Strontium-90	pCi/l	22	41	1.0E-01	8.5E-01	4.6E+00	3.2E+00
Sulfate	mg/l	74	75	2.0E+00	7.6E+00	4.1E+01	2.4E+01	
Thallium	µg/l	5	78	4.0E-02	7.9E+00	1.9E+01	2.5E+01	
Tin	µg/l	7	67	1.0E+01	1.6E+01	3.4E+01	3.5E+01	

TABLE C-6.—Groundwater Detection Statistics by Regime and Analyte
(Environmental Surveillance Report Data 1991 to 1996)-Continued

GROUNDWATER REGIME ^a	ANALYTE	UNITS ^b	DETECTED	ANALYZED	MINIMUM	MEAN	MAXIMUM	95% UCL ^c
Main Aquifer Supply Wells (cont.)	Total Dissolved Solids	mg/l	75	82	9.0E+01	2.1E+02	5.3E+02	3.9E+02
	Tritium	nCi/l	40	76	3.0E-03	3.4E-01	1.1E+00	7.8E-01
	Uranium	µg/l	52	77	6.0E-02	2.1E+00	1.7E+01	8.6E+00
	Vanadium	µg/l	67	79	5.0E+00	2.9E+01	2.6E+02	1.0E+02
	Zinc	µg/l	46	79	3.9E+00	6.8E+01	1.3E+03	4.5E+02
	Acetone	µg/l	4	5	3.2E+01	4.0E+01	5.9E+01	6.6E+01
	Aluminum	µg/l	18	55	3.0E+01	1.7E+02	1.0E+03	6.7E+02
	Americium-241	pCi/l	32	49	6.0E-03	2.7E-02	6.2E-02	5.7E-02
	Antimony	µg/l	14	54	6.0E-01	2.7E+01	2.8E+02	1.7E+02
	Arsenic	µg/l	23	56	1.0E+00	3.4E+00	1.2E+01	7.5E+00
Test Wells	Barium	µg/l	43	48	3.0E+00	3.0E+01	9.1E+01	7.8E+01
	Beryllium	µg/l	3	55	1.0E+00	1.5E+00	2.0E+00	2.5E+00
	Bicarbonate	mg/l	56	56	3.2E+01	6.6E+01	1.1E+02	1.0E+02
	Boron	µg/l	40	55	1.0E+01	4.9E+01	3.0E+02	1.6E+02
	Bromine	µg/l	1	1	4.0E+01	4.0E+01	4.0E+01	
	Cadmium	µg/l	10	55	1.0E-01	4.3E+00	1.3E+01	1.3E+01
	Calcium	mg/l	55	55	2.1E+00	1.5E+01	5.2E+01	4.0E+01
	Carbonate	mg/l	4	56	1.0E+00	2.5E+00	3.0E+00	4.5E+00
	Cesium-137	pCi/l	29	55	2.0E-02	1.2E+01	1.6E+02	8.8E+01
	Chlorine	mg/l	81	81	1.0E+00	7.0E+00	5.6E+01	3.0E+01
	Chromium	µg/l	19	55	1.0E+00	1.1E+01	6.3E+01	4.0E+01
	Cobalt	µg/l	5	55	3.0E+00	7.9E+00	2.2E+01	2.3E+01
	Copper	µg/l	25	55	3.0E+00	1.2E+02	8.0E+02	4.8E+02
	Cyanide	mg/l	4	44	1.0E-02	1.0E-02	1.0E-02	1.0E-02

TABLE C-6.—Groundwater Detection Statistics by Regime and Analyte
(Environmental Surveillance Report Data 1991 to 1996)-Continued

GROUNDWATER REGIME ^a	ANALYTE	UNITS ^b	DETECTED	ANALYZED	MINIMUM	MEAN	MAXIMUM	95% UCL ^c
Test Wells (cont.)	Di-n-butyl phthalate	µg/l	2	7	1.5E+01	1.5E+01	1.5E+01	1.5E+01
	Fluorine	mg/l	55	55	1.0E-01	3.1E-01	6.0E-01	5.6E-01
	Gross Alpha	pCi/l	33	57	1.8E-01	1.4E+00	9.0E+00	4.4E+00
	Gross Beta	pCi/l	57	57	1.0E+00	3.2E+00	1.2E+01	7.1E+00
	Gross Gamma	pCi/l	30	58	2.0E+00	8.0E+01	3.2E+02	2.4E+02
	Hardness	mg/l	53	54	5.7E+00	5.7E+01	1.8E+02	1.4E+02
	Iron	µg/l	48	55	4.5E+01	2.3E+03	2.0E+04	1.0E+04
	Lead	µg/l	45	56	1.0E+00	2.6E+02	9.0E+03	2.9E+03
	Lithium	mg/l	10	10	1.0E-02	2.1E-02	2.8E-02	3.1E-02
	Magnesium	mg/l	54	55	1.2E-01	4.3E+00	1.1E+01	8.9E+00
	Manganese	µg/l	44	55	1.0E+00	5.6E+01	4.8E+02	2.2E+02
	Mercury	µg/l	7	56	7.8E-02	2.1E-01	7.0E-01	6.5E-01
	Molybdenum	µg/l	7	55	3.0E+00	1.3E+02	7.2E+02	6.7E+02
	Nickel	µg/l	9	55	4.0E-01	2.9E+01	9.0E+01	8.0E+01
	Nitrate, as Nitrogen	mg/l	66	81	4.0E-02	1.4E+00	2.3E+01	8.3E+00
	pH		56	56	6.7E+00		8.6E+00	
	Phosphate	mg/l	1	1	5.0E-02	5.0E-02	5.0E-02	
	Phosphate, as Phosphorous	mg/l	22	50	1.6E-02	1.2E-01	4.0E-01	3.4E-01
	Plutonium-238	pCi/l	36	67	1.0E-03	1.3E-02	4.3E-02	4.0E-02
	Plutonium-239, Plutonium-240	pCi/l	48	67	1.0E-03	2.7E-02	2.3E-01	1.2E-01
	Potassium	mg/l	43	55	8.4E-01	2.0E+00	4.7E+00	3.9E+00
	Selenium	µg/l	12	56	1.0E+00	8.3E+00	4.0E+01	3.8E+01

TABLE C-6.—Groundwater Detection Statistics by Regime and Analyte
(Environmental Surveillance Report Data 1991 to 1996)-Continued

GROUNDWATER REGIME ^a	ANALYTE	UNITS ^b	DETECTED	ANALYZED	MINIMUM	MEAN	MAXIMUM	95% UCL ^c
Test Wells (cont.)	Silica	mg/l	54	57	5.0E+00	5.5E+01	8.4E+01	1.0E+02
	Silver	µg/l	3	55	1.3E+01	1.7E+01	2.0E+01	2.5E+01
	Sodium	mg/l	55	55	5.0E+00	1.4E+01	1.4E+02	4.8E+01
	Strontium	µg/l	54	55	3.5E+01	9.3E+01	8.0E+02	3.3E+02
	Strontium-90	pCi/l	53	75	1.0E-01	1.4E+00	3.5E+01	1.1E+01
	Sulfate	mg/l	53	56	1.0E+00	6.2E+00	2.5E+01	2.0E+01
	Thallium	µg/l	1	54	2.3E-01	2.3E-01	2.3E-01	
	Tin	µg/l	6	52	1.0E+01	4.4E+01	9.0E+01	1.0E+02
	Toluene	µg/l	2	5	9.0E+00	1.2E+01	1.4E+01	1.9E+01
	Total Dissolved Solids	mg/l	54	56	8.0E+00	1.7E+02	1.9E+03	6.6E+02
	Total Suspended Solids	mg/l	10	28	1.0E+00	6.2E+00	2.6E+01	2.1E+01
	Tritium	nCi/l	33	59	2.0E-02	4.4E-01	2.1E+00	1.4E+00
	Uranium	µg/l	43	57	4.0E-02	6.3E-01	2.7E+00	2.0E+00
	Vanadium	µg/l	22	55	1.0E+00	7.5E+00	1.5E+01	1.7E+01
	Zinc	µg/l	53	55	1.9E+01	1.2E+03	7.0E+03	4.2E+03
	Acetone	µg/l	13	18	2.0E+01	2.9E+01	4.4E+01	4.5E+01
	Springs	Aluminum	µg/l	91	124	1.0E+01	2.5E+03	4.1E+04
Americium-241		pCi/l	64	80	2.4E-03	3.6E-02	7.9E-02	7.7E-02
Ammonia, as Nitrogen		µg/l	21	124	6.0E+00	5.3E+01	8.3E+02	4.1E+02
Antimony		µg/l	15	124	2.0E-01	1.0E+00	7.0E+00	4.5E+00
Arsenic		µg/l	84	124	1.0E+00	6.1E+00	7.0E+01	2.6E+01
Barium		µg/l	99	101	7.0E+00	8.7E+01	8.3E+02	3.6E+02
Beryllium		µg/l	20	124	5.0E-01	1.7E+00	1.3E+01	7.3E+00

TABLE C-6.—Groundwater Detection Statistics by Regime and Analyte
(Environmental Surveillance Report Data 1991 to 1996)-Continued

GROUNDWATER REGIME ^a	ANALYTE	UNITS ^b	DETECTED	ANALYZED	MINIMUM	MEAN	MAXIMUM	95% UCL ^c
Springs (cont.)	Bicarbonate	mg/l	123	123	4.2E+01	9.4E+01	5.0E+02	2.1E+02
	Boron	µg/l	107	124	2.0E+00	3.5E+01	2.0E+02	9.8E+01
	Bromine	µg/l	3	4	2.0E+01	4.7E+01	6.0E+01	9.3E+01
	Butanone [2-]	µg/l	2	18	2.3E+01	2.5E+01	2.6E+01	2.9E+01
	Cadmium	µg/l	34	124	2.0E-01	3.5E+00	1.7E+01	1.1E+01
	Calcium	mg/l	121	123	4.2E-01	2.3E+01	1.1E+02	5.7E+01
	Carbonate	mg/l	3	123	2.0E+00	7.0E+00	1.7E+01	2.4E+01
	Cesium-137	pCi/l	58	118	1.0E-02	2.5E+01	1.4E+02	1.1E+02
	Chlorine	mg/l	123	123	1.0E+00	5.4E+00	3.3E+01	1.5E+01
	Chloroethane	µg/l	3	18	1.1E+01	1.2E+01	1.4E+01	1.5E+01
	Chromium	µg/l	85	124	1.0E+00	9.3E+00	1.2E+02	3.7E+01
	Cobalt	µg/l	11	101	3.0E+00	9.7E+00	3.3E+01	2.9E+01
	Copper	µg/l	38	124	1.0E+00	1.5E+01	2.5E+02	9.5E+01
	Cyanide	mg/l	4	101	1.0E-02	5.8E-02	1.2E-01	1.5E-01
	Di-n-butyl phthalate	µg/l	4	20	1.4E+01	2.0E+01	3.7E+01	4.3E+01
	Dinitrotoluene [2,4-]	µg/l	1	38	1.8E-01	1.8E-01	1.8E-01	
	Fluorine	mg/l	123	123	2.9E-01	4.9E-01	1.4E+00	8.3E-01
	Gross Alpha	pCi/l	93	124	1.0E-01	3.4E+00	3.6E+01	1.4E+01
	Gross Beta	pCi/l	124	124	1.5E+00	5.2E+00	6.2E+01	1.8E+01
	Gross Gamma	pCi/l	77	124	1.0E+01	1.2E+02	1.0E+03	4.3E+02
	Hardness	mg/l	119	123	1.3E+01	7.7E+01	5.8E+02	2.1E+02
	HMX (Octogen)	µg/l	1	17	4.9E+00	4.9E+00	4.9E+00	
	Iron	µg/l	94	124	1.0E+01	2.3E+03	2.9E+04	1.4E+04
	Lead	µg/l	66	127	2.0E-01	8.9E+00	2.0E+02	6.6E+01

TABLE C-6.—Groundwater Detection Statistics by Regime and Analyte
(Environmental Surveillance Report Data 1991 to 1996)-Continued

GROUNDWATER REGIME ^a	ANALYTE	UNITS ^b	DETECTED	ANALYZED	MINIMUM	MEAN	MAXIMUM	95% UCL ^c
Springs (cont.)	Lithium	mg/l	16	16	2.0E-02	2.8E-02	5.8E-02	5.0E-02
	Magnesium	mg/l	120	123	4.0E-01	3.7E+00	1.8E+01	8.7E+00
	Manganese	µg/l	85	124	1.0E+00	2.0E+02	7.0E+03	1.8E+03
	Mercury	µg/l	3	124	1.0E-01	2.7E-01	6.0E-01	8.4E-01
	Methylene chloride	µg/l	3	18	5.0E+00	5.0E+00	5.0E+00	5.0E+00
	Molybdenum	µg/l	25	103	1.0E+00	4.0E+00	1.6E+01	1.3E+01
	Nitrate, as Nitrogen	mg/l	96	126	2.0E-02	1.0E+00	2.8E+01	6.8E+00
	pH		123	123	6.8E+00		8.9E+00	
	Phosphate, as Phosphorous	mg/l	58	123	2.0E-02	4.5E-01	5.1E+00	2.3E+00
	Plutonium-238	pCi/l	80	125	3.0E-04	1.7E-02	1.4E-01	5.7E-02
	Plutonium-239, Plutonium-240	pCi/l	87	125	1.0E-03	1.8E-02	6.2E-02	4.6E-02
	Potassium	mg/l	120	123	2.0E-01	2.9E+00	9.4E+00	6.1E+00
	RDX (Cyclonite)	µg/l	1	18	2.3E+01	2.3E+01	2.3E+01	
	Selenium	µg/l	26	124	1.0E+00	6.5E+00	7.0E+01	3.5E+01
	Silica	mg/l	127	127	2.2E+01	6.1E+01	8.8E+01	9.5E+01
	Silver	µg/l	8	124	1.0E+00	3.0E+01	1.3E+02	1.2E+02
	Sodium	mg/l	120	123	5.0E+00	2.1E+01	1.4E+02	6.7E+01
	Strontium	µg/l	124	124	1.0E+00	1.9E+02	1.4E+03	5.4E+02
	Strontium-90	pCi/l	68	101	1.0E-01	9.5E-01	2.0E+01	5.8E+00
	Sulfate	mg/l	123	123	1.0E+00	6.7E+00	3.3E+01	1.6E+01
Tetryl(methyl-2,4,6-trinitrophenyl)nitramine)	µg/l	1	18	6.1E-01	6.1E-01	6.1E-01		

TABLE C-6.—Groundwater Detection Statistics by Regime and Analyte
(Environmental Surveillance Report Data 1991 to 1996)-Continued

GROUNDWATER REGIME ^a	ANALYTE	UNITS ^b	DETECTED	ANALYZED	MINIMUM	MEAN	MAXIMUM	95% UCL ^c
Springs (cont.)	Thallium	µg/l	9	124	4.0E-02	2.8E+00	1.6E+01	1.3E+01
	Tin	µg/l	13	78	8.0E+00	3.5E+01	5.9E+01	6.4E+01
	Total Dissolved Solids	mg/l	123	123	6.0E+00	2.0E+02	2.1E+03	6.0E+02
	Total Suspended Solids	mg/l	10	32	1.2E+00	1.4E+01	8.4E+01	6.5E+01
	Trinitrotoluene [2,4,6-]	µg/l	2	18	2.0E-01	2.5E+00	4.8E+00	9.0E+00
	Tritium	nCi/l	83	124	1.5E-02	3.5E-01	3.8E+00	1.2E+00
	Uranium	µg/l	133	143	1.0E-01	2.7E+00	3.9E+01	1.3E+01
	Vanadium	µg/l	111	124	1.0E+00	2.0E+01	1.6E+02	7.5E+01
	Zinc	µg/l	60	124	1.0E+00	1.6E+02	6.5E+03	1.8E+03
	Aluminum	µg/l	5	6	9.0E+01	6.1E+02	1.2E+03	1.6E+03
	Americium-241	pCi/l	3	4	3.0E-03	1.8E-02	3.0E-02	4.6E-02
	Arsenic	µg/l	1	6	1.5E+00	1.5E+00	1.5E+00	
	Barium	µg/l	4	5	1.2E+01	6.9E+01	2.3E+02	2.9E+02
	Bicarbonate	mg/l	6	6	2.8E+01	4.3E+01	6.7E+01	7.0E+01
Springs from Volcanics (Water Canyon Gallery)	Boron	µg/l	1	6	2.4E+01	2.4E+01	2.4E+01	
	Calcium	mg/l	6	6	6.0E+00	7.5E+00	1.1E+01	1.1E+01
	\Cesium-137	pCi/l	3	6	2.2E-01	5.1E+01	1.5E+02	2.2E+02
	Chlorine	mg/l	6	6	1.0E+00	3.2E+00	1.2E+01	1.2E+01
	Chromium	µg/l	2	6	5.3E+00	6.2E+00	7.0E+00	8.6E+00
	Copper	µg/l	2	6	3.0E+00	5.5E+00	8.0E+00	1.3E+01
	Fluorine	mg/l	2	6	6.0E-02	1.3E-01	2.0E-01	3.3E-01
	Gross Alpha	pCi/l	5	6	4.4E-01	8.9E-01	1.0E+00	1.4E+00
	Gross Beta	pCi/l	6	6	2.0E+00	3.4E+00	5.0E+00	6.0E+00

TABLE C-6.—Groundwater Detection Statistics by Regime and Analyte
(Environmental Surveillance Report Data 1991 to 1996)-Continued

GROUNDWATER REGIME ^a	ANALYTE	UNITS ^b	DETECTED	ANALYZED	MINIMUM	MEAN	MAXIMUM	95% UCL ^c
Springs from Volcanics (Water Canyon Gallery) (cont.)	Gross Gamma	pCi/l	3	5	3.0E+01	2.9E+02	8.2E+02	1.2E+03
	Hardness	mg/l	6	6	2.5E+01	3.1E+01	3.9E+01	4.0E+01
	Iron	µg/l	4	6	4.0E+01	3.5E+02	5.6E+02	8.2E+02
	Lead	µg/l	1	6	1.7E+00	1.7E+00	1.7E+00	
	Lithium	mg/l	1	1	9.0E-03	9.0E-03	9.0E-03	
	Magnesium	mg/l	5	6	3.0E+00	3.3E+00	3.8E+00	3.9E+00
	Manganese	µg/l	2	6	2.0E+00	2.5E+00	3.0E+00	3.9E+00
	Molybdenum	µg/l	1	6	2.0E+00	2.0E+00	2.0E+00	
	Nickel	µg/l	1	6	2.0E+01	2.0E+01	2.0E+01	
	Nitrate, as Nitrogen	mg/l	6	6	1.5E-01	3.7E-01	9.7E-01	9.7E-01
	pH		6	6	6.9E+00		8.0E+00	
	Phosphate, as Phosphorous	mg/l	3	6	4.0E-02	1.5E-01	2.0E-01	3.3E-01
	Plutonium-238	pCi/l	5	6	3.0E-03	5.8E-03	9.0E-03	1.1E-02
	Plutonium-239, Plutonium-240	pCi/l	5	6	4.0E-03	1.3E-02	2.2E-02	2.7E-02
	Potassium	mg/l	5	6	1.5E+00	2.1E+00	3.0E+00	3.3E+00
	Selenium	µg/l	1	6	4.0E+00	4.0E+00	4.0E+00	
	Silica	mg/l	6	6	1.6E+01	4.0E+01	4.8E+01	6.4E+01
	Sodium	mg/l	5	6	5.1E+00	7.2E+00	1.2E+01	1.3E+01
	Strontium	µg/l	5	6	4.2E+01	5.6E+01	8.1E+01	8.5E+01
	Strontium-90	pCi/l	1	3	1.0E-01	1.0E-01	1.0E-01	
Sulfate	mg/l	6	6	2.0E+00	3.1E+00	6.0E+00	6.2E+00	
Thallium	µg/l	1	6	1.2E+00	1.2E+00	1.2E+00		

TABLE C-6.—Groundwater Detection Statistics by Regime and Analyte
(Environmental Surveillance Report Data 1991 to 1996)-Continued

GROUNDWATER REGIME ^a	ANALYTE	UNITS ^b	DETECTED	ANALYZED	MINIMUM	MEAN	MAXIMUM	95% UCL ^c
Springs from Volcanics (Water Canyon Gallery) (cont.)	Total Dissolved Solids	mg/l	5	6	6.8E+01	9.5E+01	1.4E+02	1.5E+02
	Total Suspended Solids	mg/l	2	2	2.0E+00	2.0E+00	2.0E+00	2.0E+00
	Tritium	nCi/l	3	6	1.0E-01	4.3E-01	1.0E+00	1.4E+00
	Uranium	µg/l	3	6	1.0E-01	2.5E-01	4.0E-01	5.5E-01
	Vanadium	µg/l	3	6	4.0E+00	8.3E+00	1.1E+01	1.6E+01
	Zinc	µg/l	1	6	3.0E+01	3.0E+01	3.0E+01	
	Acetone	µg/l	1	12	3.10E+01	3.10E+01	3.10E+01	
	Aluminum	µg/l	12	47	3.00E+01	1.04E+02	1.60E+02	1.93E+02
	Americium-241	pCi/l	36	46	2.00E-03	2.64E-02	7.50E-02	6.02E-02
	Antimony	µg/l	17	47	3.00E-01	1.98E+00	8.00E+00	6.70E+00
San Ildefonso Wells	Arsenic	µg/l	47	52	2.00E+00	8.66E+00	4.10E+01	2.14E+01
	Barium	µg/l	48	51	1.00E+00	9.68E+01	3.30E+02	3.33E+01
	Beryllium	µg/l	6	52	1.00E+00	7.00E+00	1.70E+01	2.04E+01
	Bicarbonate	mg/l	52	52	6.80E+01	2.11E+02	5.71E+02	4.73E+02
	Bis(2-ethylhexyl) phthalate	µg/l	10	19	1.10E+01	1.48E+01	1.90E+01	2.15E+01
	Boron	µg/l	45	47	8.00E+00	4.02E+02	2.20E+03	1.65E+03
	Bromine	µg/l	8	8	7.00E+01	4.83E+02	1.78E+03	1.71E+03
	Cadmium	µg/l	5	52	2.00E-01	1.34E+00	5.00E+00	5.49E+00
	Calcium	mg/l	52	52	2.80E+00	2.88E+01	8.50E+01	7.61E+01
	Carbonate	mg/l	22	52	1.00E+00	1.01E+01	3.40E+01	2.70E+01
	Cesium-137	pCi/l	35	52	1.50E-01	1.19E+01	9.00E+01	5.87E+01
	Chlorine	mg/l	52	52	3.00E+00	6.57E+01	4.46E+02	2.83E+02
	Chloroethane	µg/l	6	12	1.30E+01	1.52E+01	1.80E+01	1.86E+01

TABLE C-6.—Groundwater Detection Statistics by Regime and Analyte
(Environmental Surveillance Report Data 1991 to 1996)-Continued

GROUNDWATER REGIME ^a	ANALYTE	UNITS ^b	DETECTED	ANALYZED	MINIMUM	MEAN	MAXIMUM	95% UCL ^c
San Idefonso Wells (cont.)	Chromium	µg/l	23	52	2.00E-01	1.28E+01	5.50E+01	3.53E+01
	Cobalt	µg/l	6	47	4.00E+00	1.58E+01	5.50E+01	5.61E+01
	Copper	µg/l	28	52	2.00E+00	1.58E+01	1.20E+02	5.98E+01
	Cyanide	mg/l	1	30	3.00E-02	3.00E-02	3.00E-02	
	Di-n-butyl phthalate	µg/l	1	19	1.10E+01	1.10E+01	1.10E+01	
	Fluorine	mg/l	52	52	1.30E-01	2.04E+00	4.90E+01	1.56E+01
	Gross Alpha	pCi/l	35	52	2.10E-01	9.04E+00	4.00E+01	2.74E+01
	Gross Beta	pCi/l	50	52	8.00E-01	5.11E+00	1.70E+01	1.25E+01
	Gross Gamma	pCi/l	33	47	1.00E+01	1.31E+02	5.00E+02	3.86E+02
	Hardness	mg/l	52	52	8.00E+00	8.04E+01	2.35E+02	2.16E+02
	Iron	µg/l	33	52	2.00E+01	6.67E+02	9.60E+03	4.21E+03
	Lead	µg/l	14	62	5.00E-01	2.43E+00	6.00E+00	5.78E+00
	Lithium	mg/l	8	8	3.00E-02	1.05E-01	2.90E-01	2.80E-01
	Magnesium	mg/l	47	52	4.00E-02	2.33E+00	7.80E+00	6.66E+00
	Manganese	µg/l	29	52	1.00E+00	7.59E+00	3.60E+01	2.20E+01
	Mercury	µg/l	6	51	1.00E-01	4.17E-01	1.00E+00	1.26E+00
	Molybdenum	µg/l	21	47	1.70E+00	1.31E+01	5.70E+01	4.41E+01
	Nickel	µg/l	3	47	1.00E+01	2.27E+01	3.00E+01	4.47E+01
	Nitrate, as Nitrogen	mg/l	55	60	2.49E-02	2.75E+00	1.90E+01	1.11E+01
	Phosphate	mg/l	2	8	1.00E-01	1.25E-01	1.50E-01	1.96E-01
	Phosphate, as Phosphorous	mg/l	11	45	3.27E-02	1.21E-01	4.00E-01	3.15E-01
	Plutonium-238	pCi/l	29	52	3.00E-03	2.61E-02	1.10E-01	8.51E-02

TABLE C-6.—Groundwater Detection Statistics by Regime and Analyte
(Environmental Surveillance Report Data 1991 to 1996)-Continued

GROUNDWATER REGIME ^a	ANALYTE	UNITS ^b	DETECTED	ANALYZED	MINIMUM	MEAN	MAXIMUM	95% UCL ^c
San Idefonso Wells (cont.)	Plutonium-239, Plutonium-240	pCi/l	37	52	9.00E-04	2.83E-02	3.37E-01	1.42E-01
	Potassium	mg/l	46	52	5.30E-01	2.37E+00	6.00E+00	5.04E+00
	Selenium	µg/l	14	52	2.00E+00	3.37E+00	6.50E+00	6.37E+00
	Silica	mg/l	57	60	2.10E+01	3.59E+01	6.30E+01	5.72E+01
	Silver	µg/l	5	52	1.00E+00	2.64E+01	4.40E+01	6.76E+01
	Sodium	mg/l	52	52	1.40E+01	1.23E+02	5.20E+02	3.80E+02
	Strontium	µg/l	47	47	2.68E+01	4.31E+02	1.50E+03	1.18E+03
	Strontium-90	pCi/l	33	46	1.00E-01	7.21E-01	8.40E+00	3.67E+00
	Sulfate	mg/l	52	52	4.00E+00	3.08E+01	8.20E+01	7.36E+01
	Thallium	µg/l	12	47	3.00E-02	1.93E-01	9.00E-01	7.35E-01
	Tin	µg/l	1	40	1.00E+01	1.00E+01	1.00E+01	
	Total Dissolved Solids	mg/l	52	52	1.10E+02	4.56E+02	1.45E+03	1.17E+03
	Total Suspended Solids	mg/l	2	18	2.00E+00	2.40E+00	2.80E+00	3.53E+00
	Trichloroethane [1,1,1-]	µg/l	1	12	2.30E+01	2.30E+01	2.30E+01	
	Tritium	nCi/l	34	52	9.80E-02	3.94E-01	2.10E+00	1.10E+00
	Uranium	µg/l	50	52	2.00E-01	1.11E+01	3.52E+01	2.97E+01
	Vanadium	µg/l	44	47	5.00E+00	1.87E+01	6.00E+01	3.90E+01
Zinc	µg/l	36	52	3.90E+00	1.11E+02	1.30E+03	5.61E+02	

^a Groundwater regime designations are in accordance with the Environmental Surveillance Program.

^b pCi/l is picocuries of radioactive analyte per liter of sample, nCi/l is nanocuries of radioactive analyte per liter, µg/l is micrograms of analyte per liter of sample, mg/l is milligrams of analyte per liter of sample, NTU is nephelometric turbidity units.

^c Upper confidence limit (UCL) not calculated when the number of detected analyses equals 1.

**TABLE C-7.—Groundwater Detection Statistics by Watershed and by Analyte
(Environmental Surveillance Report Data 1991 to 1996)**

GROUNDWATER REGIME^a	ANALYTE	UNITS^b	DETECTED	ANALYZED	MINIMUM	MEAN	MAX
Alluvial Groundwater Cañada del Buey	Aluminum	µg/l	8	8	4.7E+03	5.9E+04	1.6
	Americium-241	pCi/l	6	6	1.8E-02	2.7E-02	4.1
	Ammonia, as Nitrogen	mg/l	4	11	3.0E-02	1.0E-01	2.4
	Antimony	µg/l	1	6	1.0E+00	1.0E+00	1.0
	Arsenic	µg/l	8	8	5.0E+00	2.3E+01	7.2
	Barium	µg/l	8	8	8.3E+01	6.9E+02	1.6
	Beryllium	µg/l	5	8	3.0E+00	8.6E+00	2.0
	Bicarbonate	mg/l	8	8	6.6E+01	7.6E+01	9.8
	Boron	µg/l	8	8	3.7E+01	5.5E+01	9.0
	Cadmium	µg/l	3	8	1.0E+00	3.0E+00	5.0
	Calcium	mg/l	8	8	1.3E+01	2.5E+01	4.2
	Cesium-137	pCi/l	1	8	2.1E+00	2.1E+00	2.1
	Chlorine	mg/l	8	8	7.0E+00	1.1E+01	1.3
	Chromium	µg/l	6	8	1.2E+01	4.0E+01	1.0
	Cobalt	µg/l	5	8	4.0E+00	1.2E+01	2.8
	Copper	µg/l	6	8	5.0E+00	2.8E+01	7.1
	Cyanide	mg/l	2	7	5.0E-02	5.5E-02	6.0
	Fluorine	mg/l	8	8	1.0E-01	1.9E-01	3.0
	Gross Alpha	pCi/l	8	8	3.0E+00	1.3E+01	2.6
	Gross Beta	pCi/l	8	8	7.0E+00	1.8E+01	2.9
	Gross Gamma	pCi/l	6	8	4.0E+01	1.2E+02	4.0
Hardness	mg/l	8	8	5.3E+01	1.0E+02	1.9	
Iron	µg/l	8	8	2.2E+03	3.6E+04	1.3	
Lead	µg/l	5	6	3.0E+00	8.3E+01	2.4	
Lithium	mg/l	2	2	3.4E-02	6.5E-02	9.5	

**TABLE C-7.—Groundwater Detection Statistics by Watershed and by Analyte
(Environmental Surveillance Report Data 1991 to 1996)-Continued**

GROUNDWATER REGIME^a	ANALYTE	UNITS^b	DETECTED	ANALYZED	MINIMUM	MEAN	MAXIMUM	95% UCL^c
Alluvial Groundwater Cañada del Buey (cont.)	Magnesium	mg/l	8	8	3.8E+00	9.7E+00	2.1E+01	2.0E+01
	Manganese	µg/l	8	8	4.0E+00	8.6E+02	2.4E+03	2.6E+03
	Mercury	µg/l	3	8	2.0E-01	3.3E-01	6.0E-01	8.0E-01
	Molybdenum	µg/l	1	8	2.0E+00	2.0E+00	2.0E+00	
	Nickel	µg/l	6	8	1.0E+01	3.3E+01	8.0E+01	8.2E+01
	Nitrate, as Nitrogen	mg/l	15	18	4.0E-02	1.4E+00	1.7E+01	1.0E+01
	Nitrite, as Nitrogen	mg/l	4	11	2.0E-02	4.5E-02	9.0E-02	1.1E-01
	pH		8	8	6.8E+00		9.0E+00	
	Phosphate, as Phosphorous	mg/l	7	7	1.0E-01	3.9E-01	6.0E-01	7.2E-01
	Plutonium-238	pCi/l	4	8	2.0E-03	1.9E-02	3.4E-02	5.0E-02
	Plutonium-239, Plutonium-240	pCi/l	5	8	3.0E-03	1.6E-02	3.9E-02	4.3E-02
	Potassium	mg/l	8	8	2.1E+00	1.1E+01	2.2E+01	2.6E+01
	Selenium	µg/l	6	8	1.0E+00	5.4E+00	1.6E+01	1.6E+01
	Silica	mg/l	8	8	5.3E+01	6.0E+01	6.7E+01	6.9E+01
	Sodium	mg/l	8	8	2.0E+01	2.4E+01	3.0E+01	3.1E+01
	Strontium	µg/l	8	8	1.0E+02	1.8E+02	3.3E+02	3.4E+02
	Strontium-90	pCi/l	5	5	2.0E-01	5.6E-01	1.1E+00	1.4E+00
	Sulfate	mg/l	8	8	2.0E+00	7.0E+00	9.0E+00	1.2E+01
	Thallium	µg/l	2	6	2.0E+00	4.0E+00	6.0E+00	9.7E+00
	Tin	µg/l	3	8	3.0E+01	4.1E+01	5.0E+01	6.2E+01
Total Dissolved Solids	mg/l	8	8	9.6E+01	1.8E+02	2.1E+02	2.5E+02	
Total Kjeldahl Nitrogen	mg/l	9	11	4.0E-02	6.8E-01	2.5E+00	2.2E+00	

**TABLE C-7.—Groundwater Detection Statistics by Watershed and by Analyte
(Environmental Surveillance Report Data 1991 to 1996)-Continued**

GROUNDWATER REGIME^a	ANALYTE	UNITS^b	DETECTED	ANALYZED	MINIMUM	MEAN	MAXIMUM	95% UCL^c
Alluvial Groundwater Cañada del Buey (cont.)	Total Suspended Solids	mg/l	3	3	3.0E+00	1.8E+01	4.6E+01	6.7E+01
	Tritium	nCi/l	8	8	2.9E-02	4.0E-01	9.0E-01	9.1E-01
	Uranium	µg/l	7	8	2.8E-01	2.6E+00	5.8E+00	6.1E+00
	Vanadium	µg/l	7	8	1.4E+01	5.8E+01	1.5E+02	1.5E+02
	Zinc	µg/l	7	8	8.6E+01	2.4E+02	7.2E+02	6.8E+02
Los Alamos	Acetone	µg/l	2	16	2.0E+00	3.0E+00	4.0E+00	5.8E+00
	Aluminum	µg/l	69	75	1.0E+02	7.7E+03	2.4E+05	7.1E+04
	Americium-241	pCi/l	75	95	9.0E-04	3.5E+00	9.4E+01	3.2E+01
	Antimony	µg/l	3	74	7.0E-01	1.2E+00	2.0E+00	2.6E+00
	Arsenic	µg/l	24	74	1.0E+00	8.0E+00	8.3E+01	4.2E+01
	Barium	µg/l	57	69	3.0E-02	2.2E+02	3.1E+03	1.5E+03
	Barium-140	pCi/l	7	11	2.5E+00	7.0E+00	1.1E+01	1.3E+01
	Beryllium	µg/l	16	75	3.0E-01	5.9E+00	3.0E+01	2.4E+01
	Bicarbonate	mg/l	59	59	2.6E+01	6.3E+01	1.0E+02	1.0E+02
	Boron	µg/l	44	81	1.3E+01	5.7E+01	2.7E+02	1.6E+02
	Cadmium	µg/l	9	74	1.2E+00	9.3E+00	3.6E+01	3.3E+01
	Calcium	mg/l	75	75	7.5E+00	2.1E+01	3.2E+02	9.2E+01
	Cerium-144	pCi/l	18	27	1.0E+00	3.1E+01	1.1E+02	1.1E+02
	Cesium-137	pCi/l	52	73	1.3E-02	1.6E+01	2.6E+02	1.1E+02
	Chlorine	mg/l	63	63	6.0E+00	4.3E+01	1.1E+02	8.7E+01
	Chloro-3-methylphenol[4-]	µg/l	1	16	2.0E+01	2.0E+01	2.0E+01	
	Chlorophenol[o-]	µg/l	1	16	1.0E+01	1.0E+01	1.0E+01	
	Chromium	µg/l	28	75	1.8E+00	5.1E+02	7.0E+03	3.7E+03
	Cobalt	µg/l	7	75	4.0E+00	2.5E+01	7.1E+01	7.1E+01

**TABLE C-7.—Groundwater Detection Statistics by Watershed and by Analyte
(Environmental Surveillance Report Data 1991 to 1996)-Continued**

GROUNDWATER REGIME^a	ANALYTE	UNITS^b	DETECTED	ANALYZED	MINIMUM	MEAN	MAXIMUM	95% UCL^c
Los Alamos (cont.)	Cobalt-57	pCi/l	10	16	1.4E-01	5.6E+00	1.8E+01	1.7E+01
	Cobalt-60	pCi/l	24	27	1.4E-01	9.7E+00	3.7E+01	3.4E+01
	Copper	µg/l	19	75	1.3E+00	6.0E+01	8.7E+02	4.5E+02
	Cyanide	mg/l	1	57	4.0E-02	4.0E-02	4.0E-02	
	Dichlorophenol [2,4-]	µg/l	1	16	1.0E+01	1.0E+01	1.0E+01	
	Dimethylphenol [2,4-]	µg/l	1	16	1.0E+01	1.0E+01	1.0E+01	
	Di-n-butyl phthalate	µg/l	1	16	1.1E+01	1.1E+01	1.1E+01	
	Dinitrophenol [2,4-]	µg/l	1	16	5.0E+01	5.0E+01	5.0E+01	
	Europium-152	pCi/l	20	27	1.4E+00	3.3E+01	1.2E+02	1.1E+02
	Fluorine	mg/l	69	73	1.2E-01	6.6E-01	1.0E+00	1.2E+00
	Gross Alpha	pCi/l	56	73	2.0E-01	5.1E+00	7.4E+01	3.2E+01
	Gross Beta	pCi/l	72	73	2.0E+00	3.9E+01	1.5E+02	1.2E+02
	Gross Gamma	pCi/l	61	69	2.0E+00	1.3E+02	9.0E+02	4.6E+02
	Hardness	mg/l	48	48	2.5E+01	8.0E+01	1.1E+03	3.8E+02
	Iodine-129	pCi/l	1	2	3.1E+00	3.1E+00	3.1E+00	
	Iron	µg/l	71	75	5.0E+01	5.4E+03	1.9E+05	5.3E+04
	Lead	µg/l	24	74	6.0E-01	3.4E+01	4.1E+02	2.0E+02
	Lithium	mg/l	24	44	3.0E-03	3.5E-02	1.3E-01	9.8E-02
	Magnesium	mg/l	63	75	2.2E+00	5.3E+00	7.7E+01	2.4E+01
	Manganese	µg/l	50	75	7.0E-01	9.2E+02	1.4E+04	6.8E+03
Mercury	µg/l	13	74	1.0E-01	2.2E+00	1.4E+01	1.1E+01	
Methyl-4,6- dinitrophenol[2-]	µg/l	1	16	5.0E+01	5.0E+01	5.0E+01		

**TABLE C-7.—Groundwater Detection Statistics by Watershed and by Analyte
(Environmental Surveillance Report Data 1991 to 1996)-Continued**

GROUNDWATER REGIME^a	ANALYTE	UNITS^b	DETECTED	ANALYZED	MINIMUM	MEAN	MAXIMUM	95% UCL^c
Los Alamos (cont.)	Methylphenol[2-]	µg/l	1	16	1.0E+01	1.0E+01	1.0E+01	
	Methylphenol[4-]	µg/l	1	16	1.0E+01	1.0E+01	1.0E+01	
	Molybdenum	µg/l	45	76	2.0E+00	2.9E+02	1.0E+03	9.1E+02
	Neptunium-237	pCi/l	18	27	4.9E-02	2.8E+01	1.0E+02	9.6E+01
	Nickel	µg/l	9	75	1.1E+00	4.9E+01	1.7E+02	1.6E+02
	Nitrate, as Nitrogen	mg/l	54	75	4.0E-02	5.9E-01	7.3E+00	2.9E+00
	Nitrophenol[2-]	µg/l	1	16	1.0E+01	1.0E+01	1.0E+01	
	Nitrophenol[4-]	µg/l	1	16	5.0E+01	5.0E+01	5.0E+01	
	Pentachlorophenol	µg/l	1	16	5.0E+01	5.0E+01	5.0E+01	
	pH		63	63	1.0E-01		8.0E+00	
	Phenol	µg/l	1	16	1.0E+01	1.0E+01	1.0E+01	
	Phosphate, as Phosphorous	mg/l	49	55	2.0E-02	8.9E-01	2.9E+01	9.2E+00
	Phosphorous	mg/l	8	15	4.3E-02	1.3E-01	2.3E-01	2.5E-01
	Plutonium-238	pCi/l	44	74	1.0E-03	2.6E-02	3.6E-01	1.4E-01
	Plutonium-239, Plutonium-240	pCi/l	65	74	1.0E-03	7.8E-02	1.6E+00	5.3E-01
	Potassium	mg/l	69	75	1.7E+00	6.3E+00	3.0E+01	1.4E+01
	Potassium-40	pCi/l	13	16	2.2E+00	2.4E+02	5.0E+02	5.7E+02
	Ruthenium-106	pCi/l	12	27	2.2E+00	3.8E+01	1.5E+02	1.3E+02
	Selenium	µg/l	4	74	3.0E+00	5.3E+00	1.0E+01	1.2E+01
	Silica	mg/l	61	61	2.2E+01	4.0E+01	6.7E+01	5.7E+01
Silver	µg/l	4	75	4.0E-01	1.4E+01	2.6E+01	3.5E+01	
Sodium	mg/l	75	75	4.0E+00	3.2E+01	5.9E+01	5.1E+01	
Sodium-22	pCi/l	16	27	2.9E-02	3.1E+00	1.1E+01	9.9E+00	

**TABLE C-7.—Groundwater Detection Statistics by Watershed and by Analyte
(Environmental Surveillance Report Data 1991 to 1996)-Continued**

GROUNDWATER REGIME^a	ANALYTE	UNITS^b	DETECTED	ANALYZED	MINIMUM	MEAN	MAXIMUM	95% UCL^c
Los Alamos (cont.)	Strontium	µg/l	76	76	4.8E+01	1.2E+02	9.3E+02	3.5E+02
	Strontium-90	pCi/l	65	68	3.0E-01	2.2E+01	3.7E+02	1.2E+02
	Sulfate	mg/l	75	75	4.0E+00	8.9E+00	3.1E+01	1.7E+01
	Thallium	µg/l	9	74	3.0E-01	1.2E+00	3.0E+00	3.3E+00
	Tin	µg/l	2	71	3.0E+01	5.0E+01	7.0E+01	1.1E+02
	Total Dissolved Solids	mg/l	63	63	7.4E+01	2.2E+02	8.0E+02	4.5E+02
	Total Suspended Solids	mg/l	14	26	2.0E+00	8.1E+01	4.2E+02	3.4E+02
	Trichlorophenol [2,4,5-]	µg/l	1	16	5.0E+01	5.0E+01	5.0E+01	
	Trichlorophenol [2,4,6-]	µg/l	1	16	1.0E+01	1.0E+01	1.0E+01	
	Tritium	nCi/l	60	74	4.6E-02	8.2E-01	9.3E+00	3.8E+00
	Turbidity	NTU	15	15	6.0E-01	8.3E+00	8.0E+01	4.8E+01
	Uranium	µg/l	61	73	2.0E-02	1.8E+00	5.0E+01	1.5E+01
	Vanadium	µg/l	22	75	1.7E+00	2.8E+01	3.5E+02	1.8E+02
	Zinc	µg/l	34	75	9.0E-02	1.1E+02	1.6E+03	6.5E+02
Mortandad	Acetone	µg/l	1	17	2.1E+01	2.1E+01	2.1E+01	
	Actinium-228	pCi/l	3	6	1.2E+00	6.2E+00	9.8E+00	1.5E+01
	Aluminum	µg/l	59	63	2.5E+01	5.4E+03	4.4E+04	2.5E+04
	Americium-241	pCi/l	64	75	1.2E-01	2.9E+00	6.6E+01	2.3E+01
	Antimony	µg/l	10	63	2.0E-01	1.6E+00	3.0E+00	3.4E+00
	Arsenic	µg/l	27	63	2.0E+00	4.6E+00	1.2E+01	9.7E+00
	Barium	µg/l	51	57	4.0E+01	2.1E+02	9.1E+02	5.5E+02
	Barium-140	pCi/l	8	10	6.7E-01	7.1E+00	1.9E+01	2.0E+01

**TABLE C-7.—Groundwater Detection Statistics by Watershed and by Analyte
(Environmental Surveillance Report Data 1991 to 1996)-Continued**

GROUNDWATER REGIME^a	ANALYTE	UNITS^b	DETECTED	ANALYZED	MINIMUM	MEAN	MAXIMUM	95% UCL^c
Mortandad (cont.)	Benzidine[m-]	µg/l	1	15	2.0E+01	2.0E+01	2.0E+01	
	Beryllium	µg/l	11	63	1.2E+00	3.2E+00	1.2E+01	9.5E+00
	Bicarbonate	mg/l	52	53	5.9E+01	1.6E+02	2.5E+02	2.4E+02
	Bis(2-ethylhexyl) phthalate	µg/l	1	16	4.0E+00	4.0E+00	4.0E+00	
	Bismuth-211	pCi/l	2	6	3.3E+01	4.1E+01	4.8E+01	6.1E+01
	Bismuth-212	pCi/l	5	6	2.2E+01	3.8E+01	7.6E+01	8.5E+01
	Bismuth-214	pCi/l	1	6	8.3E+00	8.3E+00	8.3E+00	
	Boron	µg/l	59	65	3.0E+01	7.5E+01	1.1E+02	1.1E+02
	Cadmium	µg/l	2	63	6.0E-01	8.0E-01	1.0E+00	1.4E+00
	Cadmium-109	pCi/l	5	6	2.5E+01	4.0E+01	5.7E+01	6.9E+01
	Calcium	mg/l	63	63	1.4E+01	3.2E+01	7.3E+01	6.4E+01
	Carbonate	mg/l	2	53	1.0E+00	2.0E+00	3.0E+00	4.8E+00
	Cerium-139	pCi/l	2	6	5.5E-02	2.8E-01	5.0E-01	9.1E-01
	Cerium-144	pCi/l	13	18	1.6E+00	4.1E+01	1.6E+02	1.4E+02
	Cesium-134	pCi/l	1	6	2.4E-01	2.4E-01	2.4E-01	
	Cesium-137	pCi/l	33	57	3.6E-01	4.1E+00	3.2E+01	1.7E+01
	Chlorine	mg/l	53	53	7.0E+00	1.8E+01	3.1E+01	2.9E+01
	Chloromethane	µg/l	1	17	1.1E+01	1.1E+01	1.1E+01	
	Chromium	µg/l	23	63	1.1E+00	1.4E+01	2.8E+01	2.9E+01
	Cobalt	µg/l	8	63	5.0E+00	7.5E+00	1.2E+01	1.2E+01
	Cobalt-57	pCi/l	10	14	1.7E-01	5.0E+00	1.5E+01	1.5E+01
	Cobalt-60	pCi/l	16	18	3.0E-01	1.3E+01	4.6E+01	4.3E+01
	Copper	µg/l	24	63	5.6E+00	3.1E+01	1.0E+02	7.6E+01
Cyanide	mg/l	12	53	1.0E-02	2.0E-02	3.4E-02	3.7E-02	

**TABLE C-7.—Groundwater Detection Statistics by Watershed and by Analyte
(Environmental Surveillance Report Data 1991 to 1996)-Continued**

GROUNDWATER REGIME^a	ANALYTE	UNITS^b	DETECTED	ANALYZED	MINIMUM	MEAN	MAXIMUM	95% UCL^c
Mortandad (cont.)	Di-n-butyl phthalate	µg/l	1	16	1.2E+01	1.2E+01	1.2E+01	
	Europium-152	pCi/l	15	18	9.8E-01	2.5E+01	1.2E+02	9.2E+01
	Fluorine	mg/l	60	60	3.0E-01	1.6E+00	2.2E+00	2.4E+00
	Gross Alpha	pCi/l	52	57	6.0E-01	2.2E+01	1.4E+02	8.8E+01
	Gross Beta	pCi/l	56	57	2.0E+01	1.6E+02	6.3E+02	4.7E+02
	Gross Gamma	pCi/l	43	57	1.0E+01	1.2E+02	4.0E+02	2.9E+02
	Hardness	mg/l	47	47	4.9E+01	1.1E+02	2.4E+02	2.1E+02
	Iron	µg/l	56	63	4.0E+01	3.8E+03	3.1E+04	1.8E+04
	Lanthanum-140	pCi/l	1	6	3.8E+02	3.8E+02	3.8E+02	
	Lead	µg/l	23	67	2.0E+00	2.2E+01	5.8E+01	5.1E+01
	Lead-210	pCi/l	4	6	1.5E+02	1.0E+03	1.7E+03	2.3E+03
	Lead-211	pCi/l	3	6	1.8E+00	1.2E+01	2.6E+01	3.7E+01
	Lead-212	pCi/l	3	6	1.2E-01	3.8E+00	6.2E+00	1.0E+01
	Lead-214	pCi/l	2	6	5.0E+00	7.9E+00	1.1E+01	1.6E+01
	Lithium	mg/l	30	37	2.0E-03	2.9E-02	8.0E-02	6.6E-02
	Magnesium	mg/l	57	63	2.1E+00	5.5E+00	2.0E+01	1.2E+01
	Manganese	µg/l	41	63	2.0E+00	2.0E+02	8.6E+02	7.0E+02
	Manganese-54	pCi/l	2	6	5.2E-01	5.2E-01	5.3E-01	5.3E-01
	Mercury	µg/l	17	63	3.0E-02	4.3E-01	1.9E+00	1.4E+00
	Mercury-203	pCi/l	6	6	9.9E-02	1.7E+00	3.2E+00	4.1E+00
	Molybdenum	µg/l	59	63	2.0E-01	1.5E+02	9.4E+02	4.0E+02
	Neptunium-237	pCi/l	12	18	1.3E+00	1.7E+01	6.4E+01	6.1E+01
	Nickel	µg/l	18	63	4.8E+00	2.1E+01	1.1E+02	6.9E+01
Nitrate, as Nitrogen	mg/l	63	63	4.8E+00	2.7E+01	6.6E+01	6.0E+01	

**TABLE C-7.—Groundwater Detection Statistics by Watershed and by Analyte
(Environmental Surveillance Report Data 1991 to 1996)-Continued**

GROUNDWATER REGIME^a	ANALYTE	UNITS^b	DETECTED	ANALYZED	MINIMUM	MEAN	MAXIMUM	95% UCL^c
Mortandad (cont.)	Pentachlorophenol	µg/l	1	16	1.1E+01	1.1E+01	1.1E+01	
	pH		53	53	2.2E+00		8.6E+00	
	Phosphate, as Phosphorous	mg/l	47	47	6.0E-02	3.3E-01	9.0E-01	7.9E-01
	Phosphorous	mg/l	5	10	7.0E-02	1.0E-01	1.5E-01	1.6E-01
	Plutonium-238	pCi/l	55	57	3.0E-03	1.3E-01	2.4E+00	9.2E-01
	Plutonium-239, Plutonium-240	pCi/l	53	57	1.0E-02	3.5E-01	7.6E+00	2.9E+00
	Potassium	mg/l	63	63	3.8E+00	1.9E+01	3.6E+01	3.4E+01
	Potassium-40	pCi/l	8	14	2.8E+01	1.9E+02	3.9E+02	4.3E+02
	Protactinium-231	pCi/l	4	6	6.5E+00	1.0E+01	1.5E+01	1.8E+01
	Protactinium-233	pCi/l	3	6	1.5E-01	6.6E-01	1.3E+00	1.8E+00
	Protactinium-234M	pCi/l	5	6	2.9E+01	2.5E+02	5.0E+02	6.2E+02
	Pyridine	µg/l	2	5	1.0E+01	1.0E+01	1.0E+01	1.0E+01
	Radium-223	pCi/l	2	6	2.8E+00	5.5E+00	8.3E+00	1.3E+01
	Radium-224	pCi/l	1	6	3.2E+01	3.2E+01	3.2E+01	
	Radium-226	pCi/l	5	6	2.5E+01	9.4E+01	1.8E+02	2.2E+02
	Radon-219	pCi/l	2	6	5.9E-01	5.8E+00	1.1E+01	2.1E+01
	Ruthenium-106	pCi/l	8	18	2.1E+00	3.2E+01	6.1E+01	7.8E+01
	Selenium	µg/l	17	63	1.0E+00	2.7E+01	9.0E+01	9.9E+01
	Selenium-75	pCi/l	3	6	3.3E-01	9.6E-01	1.8E+00	2.5E+00
	Silica	mg/l	53	53	2.0E+01	4.2E+01	1.6E+02	8.5E+01
Silver	µg/l	9	62	1.0E+00	2.7E+01	1.7E+02	1.3E+02	
Sodium	mg/l	63	63	1.8E+01	9.2E+01	1.5E+02	1.4E+02	
Sodium-22	pCi/l	18	18	3.6E+00	1.2E+01	3.3E+01	2.8E+01	

**TABLE C-7.—Groundwater Detection Statistics by Watershed and by Analyte
(Environmental Surveillance Report Data 1991 to 1996)-Continued**

GROUNDWATER REGIME ^a	ANALYTE	UNITS ^b	DETECTED	ANALYZED	MINIMUM	MEAN	MAXIMUM	95% UCL ^c
Mortandad (cont.)	Strontium	µg/l	63	63	7.5E+01	1.6E+02	3.9E+02	2.9E+02
	Strontium-85	pCi/l	2	6	3.5E+00	3.5E+00	3.5E+00	3.6E+00
	Strontium-90	pCi/l	52	57	1.0E-01	3.1E+01	1.3E+02	1.0E+02
	Sulfate	mg/l	62	62	5.0E+00	2.1E+01	8.1E+01	4.6E+01
	Thallium	µg/l	10	63	4.0E-02	1.1E+00	2.2E+00	3.1E+00
	Thallium-208	pCi/l	3	6	9.4E-02	3.3E+00	6.8E+00	1.0E+01
	Thorium-227	pCi/l	3	6	5.8E+00	8.7E+00	1.3E+01	1.7E+01
	Thorium-234	pCi/l	2	6	6.0E+00	1.6E+02	3.1E+02	5.8E+02
	Tin	µg/l	1	57	1.6E+01	1.6E+01	1.6E+01	
	Tin-113	pCi/l	3	6	6.7E-01	1.1E+00	1.6E+00	2.0E+00
	Total Dissolved Solids	mg/l	55	55	2.0E+02	4.3E+02	7.9E+02	7.2E+02
	Total Suspended Solids	mg/l	13	21	1.0E+00	1.2E+02	8.6E+02	6.2E+02
	Trichlorobenzene [1,2,4-]	µg/l	1	22	5.0E+00	5.0E+00	5.0E+00	
	Tritium	nCi/l	57	57	1.4E+01	2.9E+01	1.1E+02	6.9E+01
	Turbidity	NTU	8	8	3.5E-01	3.9E+00	1.7E+01	1.6E+01
	Uranium	µg/l	58	58	4.0E-01	2.3E+00	6.5E+00	5.1E+00
	Vanadium	µg/l	21	63	3.0E+00	2.3E+01	7.0E+01	5.5E+01
	Yttrium-88	pCi/l	3	6	1.0E+00	1.7E+00	2.3E+00	3.0E+00
	Zinc	µg/l	34	63	6.0E+00	5.6E+01	1.7E+02	1.3E+02
Zinc-65	pCi/l	5	6	7.8E-01	1.2E+00	1.6E+00	2.0E+00	
Pajarito	Aluminum	µg/l	16	16	5.0E+01	1.5E+04	1.0E+05	8.2E+04
	Americium-241	pCi/l	8	8	1.0E-02	3.8E-02	6.3E-02	7.7E-02
	Antimony	µg/l	6	16	5.0E-01	1.2E+00	2.0E+00	2.5E+00

**TABLE C-7.—Groundwater Detection Statistics by Watershed and by Analyte
(Environmental Surveillance Report Data 1991 to 1996)-Continued**

GROUNDWATER REGIME^a	ANALYTE	UNITS^b	DETECTED	ANALYZED	MINIMUM	MEAN	MAXIMUM	95% UCL^c
Pajarito (cont.)	Arsenic	µg/l	8	15	3.0E+00	1.6E+01	6.8E+01	6.3E+01
	Barium	µg/l	13	13	2.9E+01	5.2E+02	2.8E+03	2.5E+03
	Beryllium	µg/l	3	13	3.0E+00	1.1E+01	1.9E+01	2.7E+01
	Bicarbonate	mg/l	17	17	2.8E+01	8.9E+01	3.2E+02	2.4E+02
	Boron	µg/l	12	16	2.0E+01	3.3E+01	5.8E+01	5.6E+01
	Cadmium	µg/l	7	16	3.0E-01	1.8E+00	7.0E+00	6.6E+00
	Calcium	mg/l	17	17	6.0E+00	4.1E+01	2.1E+02	1.4E+02
	Cesium-137	pCi/l	10	16	1.8E+00	4.2E+01	2.4E+02	2.0E+02
	Chlorine	mg/l	17	17	6.0E+00	6.9E+01	4.5E+02	2.9E+02
	Chromium	µg/l	6	13	2.0E+00	2.1E+02	7.4E+02	8.1E+02
	Cobalt	µg/l	4	16	4.0E+00	3.0E+01	5.9E+01	8.6E+01
	Copper	µg/l	9	16	2.0E+00	2.8E+01	1.3E+02	1.1E+02
	Fluorine	mg/l	13	17	1.0E-01	1.9E-01	4.4E-01	3.6E-01
	Gross Alpha	pCi/l	12	16	7.9E-01	7.7E+00	5.0E+01	3.5E+01
	Gross Beta	pCi/l	16	16	2.0E+00	9.1E+00	5.4E+01	3.4E+01
	Gross Gamma	pCi/l	15	16	2.2E+01	9.1E+01	3.4E+02	2.5E+02
	Hardness	mg/l	17	17	2.0E+01	1.7E+02	7.8E+02	6.1E+02
	Iron	µg/l	16	16	2.6E+02	1.9E+04	1.2E+05	9.5E+04
	Lead	µg/l	11	17	1.4E+00	4.0E+01	2.1E+02	1.8E+02
	Lithium	mg/l	2	3	1.0E-03	1.0E-03	1.0E-03	1.0E-03
	Magnesium	mg/l	17	17	1.4E+00	9.9E+00	4.8E+01	3.3E+01
	Manganese	µg/l	16	16	3.0E+00	1.8E+03	1.3E+04	8.6E+03
	Mercury	µg/l	8	16	1.0E-01	3.4E-01	6.0E-01	6.6E-01
Molybdenum	µg/l	7	16	1.0E+00	7.7E+00	2.0E+01	2.2E+01	
Nickel	µg/l	3	16	1.0E+01	5.8E+01	9.8E+01	1.5E+02	

**TABLE C-7.—Groundwater Detection Statistics by Watershed and by Analyte
(Environmental Surveillance Report Data 1991 to 1996)-Continued**

GROUNDWATER REGIME^a	ANALYTE	UNITS^b	DETECTED	ANALYZED	MINIMUM	MEAN	MAXIMUM	95% UCL^c
Pajarito (cont.)	Nitrate, as Nitrogen	mg/l	13	17	6.0E-02	2.9E+00	1.7E+01	1.3E+01
	pH		17	17	6.5E+00		7.5E+00	
	Phosphate, as Phosphorous	mg/l	13	14	2.0E-02	4.1E-01	3.1E+00	2.1E+00
	Plutonium-238	pCi/l	7	16	2.0E-03	2.0E-02	5.9E-02	5.9E-02
	Plutonium-239, Plutonium-240	pCi/l	14	16	4.0E-03	1.6E-02	3.6E-02	3.5E-02
	Potassium	mg/l	14	14	1.0E+00	4.1E+00	1.6E+01	1.1E+01
	Selenium	µg/l	2	15	1.0E+00	3.5E+00	6.0E+00	1.1E+01
	Silica	mg/l	17	17	2.7E+01	3.6E+01	4.7E+01	4.8E+01
	Silver	µg/l	5	16	3.0E-01	2.0E+00	5.0E+00	5.9E+00
	Sodium	mg/l	17	17	4.0E+00	3.3E+01	1.6E+02	1.1E+02
	Strontium	µg/l	16	16	5.0E+01	3.0E+02	1.5E+03	1.0E+03
	Strontium-90	pCi/l	10	10	2.0E-01	8.7E-01	1.7E+00	1.9E+00
	Sulfate	mg/l	17	17	3.3E+00	2.1E+01	1.5E+02	9.3E+01
	Thallium	µg/l	4	16	9.0E-02	1.1E+00	2.0E+00	3.2E+00
	Tin	µg/l	4	13	1.0E+01	2.4E+01	4.4E+01	5.2E+01
	Total Dissolved Solids	mg/l	17	17	1.1E+01	2.8E+02	1.4E+03	9.2E+02
	Total Suspended Solids	mg/l	1	4	1.0E+00	1.0E+00	1.0E+00	
	Tritium	nCi/l	13	16	1.0E-01	4.3E-01	8.0E-01	8.8E-01
	Uranium	µg/l	12	16	6.0E-02	2.5E+00	1.8E+01	1.3E+01
Vanadium	µg/l	6	13	1.0E+01	5.8E+01	1.4E+02	1.9E+02	
Zinc	µg/l	12	16	3.0E+00	1.0E+02	6.4E+02	4.9E+02	

**TABLE C-7.—Groundwater Detection Statistics by Watershed and by Analyte
(Environmental Surveillance Report Data 1991 to 1996)-Continued**

GROUNDWATER REGIME^a	ANALYTE	UNITS^b	DETECTED	ANALYZED	MINIMUM	MEAN	MAXIMUM	95% UCL^c
Pueblo	Acetone	µg/l	2	6	5.0E+00	5.0E+00	5.0E+00	5.0E+00
	Aluminum	µg/l	9	12	1.3E+02	2.3E+03	8.5E+03	8.6E+03
	Americium-241	pCi/l	13	17	1.8E-02	2.4E+00	1.4E+01	1.2E+01
	Antimony	µg/l	2	12	1.6E+00	1.8E+00	2.0E+00	2.4E+00
	Arsenic	µg/l	10	12	3.8E+00	8.1E+00	1.1E+01	1.3E+01
	Barium	µg/l	10	12	6.0E-02	8.9E+01	2.4E+02	2.6E+02
	Barium-140	pCi/l	2	2	6.0E+00	7.0E+00	8.0E+00	9.8E+00
	Beryllium	µg/l	1	12	8.0E+00	8.0E+00	8.0E+00	
	Bicarbonate	mg/l	10	10	1.1E+02	1.4E+02	1.7E+02	1.8E+02
	Bis(2-ethylhexyl) phthalate	µg/l	1	5	8.0E+00	8.0E+00	8.0E+00	
	Boron	µg/l	11	11	2.0E+02	2.7E+02	5.0E+02	4.5E+02
	Cadmium	µg/l	2	12	2.0E-01	6.0E-01	1.0E+00	1.7E+00
	Calcium	mg/l	12	12	1.7E+01	2.1E+01	2.7E+01	2.9E+01
	Cerium-144	pCi/l	2	6	2.8E-01	1.8E+00	3.4E+00	6.3E+00
	Cesium-137	pCi/l	7	11	7.8E-01	3.6E+00	1.3E+01	1.3E+01
	Chlorine	mg/l	10	10	3.5E+01	3.8E+01	4.7E+01	4.5E+01
	Chromium	µg/l	4	12	6.0E+00	3.3E+03	7.7E+03	1.1E+04
	Cobalt	µg/l	5	12	3.1E+00	8.3E+00	1.7E+01	1.9E+01
	Cobalt-57	pCi/l	3	4	3.3E-01	1.0E+00	1.8E+00	2.5E+00
	Cobalt-60	pCi/l	5	6	1.2E+00	8.1E+00	1.9E+01	2.6E+01
	Copper	µg/l	5	12	2.5E+00	1.5E+01	5.1E+01	5.6E+01
	Europium-152	pCi/l	5	6	3.0E+00	2.4E+01	7.1E+01	8.2E+01
	Fluorine	mg/l	12	12	4.0E-01	5.6E-01	7.0E-01	7.2E-01
Gross Alpha	pCi/l	6	12	2.0E-01	3.6E+00	9.0E+00	1.0E+01	

**TABLE C-7.—Groundwater Detection Statistics by Watershed and by Analyte
(Environmental Surveillance Report Data 1991 to 1996)-Continued**

GROUNDWATER REGIME^a	ANALYTE	UNITS^b	DETECTED	ANALYZED	MINIMUM	MEAN	MAXIMUM	95% UCL^c
Pueblo (cont.)	Gross Beta	pCi/l	12	12	1.0E+01	1.4E+01	1.9E+01	2.0E+01
	Gross Gamma	pCi/l	10	10	3.6E+01	1.2E+02	2.8E+02	2.8E+02
	Hardness	mg/l	6	6	7.0E+01	8.2E+01	8.7E+01	9.5E+01
	Iodine-129	pCi/l	1	1	7.7E-01	7.7E-01	7.7E-01	
	Iron	μg/l	10	12	5.0E+01	1.4E+03	5.6E+03	5.7E+03
	Lead	μg/l	5	12	1.0E+00	6.0E+00	1.8E+01	2.0E+01
	Lithium	mg/l	5	8	2.0E-02	2.8E-02	4.7E-02	5.0E-02
	Magnesium	mg/l	10	12	3.5E+00	4.6E+00	5.8E+00	6.4E+00
	Manganese	μg/l	12	12	1.3E+02	1.5E+03	6.6E+03	5.0E+03
	Molybdenum	μg/l	2	12	1.2E+00	3.6E+00	6.0E+00	1.0E+01
	Neptunium-237	pCi/l	2	6	9.0E+00	5.8E+01	1.1E+02	1.9E+02
	Nickel	μg/l	3	12	4.7E+00	6.7E+00	1.0E+01	1.2E+01
	Nitrate, as Nitrogen	mg/l	11	12	3.4E-01	3.0E+00	1.4E+01	1.1E+01
	pH		10	10	6.9E+00		7.7E+00	
	Phosphate, as Phosphorous	mg/l	7	7	2.2E+00	3.4E+00	4.9E+00	5.5E+00
	Phosphorous	mg/l	4	4	8.2E-02	2.4E+00	4.8E+00	7.9E+00
	Plutonium-238	pCi/l	7	12	3.0E-03	2.1E-02	8.9E-02	8.3E-02
	Plutonium-239, Plutonium-240	pCi/l	12	12	2.4E-02	1.1E-01	4.0E-01	3.4E-01
	Potassium	mg/l	12	12	1.0E+01	1.4E+01	2.1E+01	2.0E+01
	Potassium-40	pCi/l	3	4	6.7E+00	8.2E+02	1.3E+03	2.2E+03
Ruthenium-106	pCi/l	3	6	3.2E+00	7.9E+00	1.1E+01	1.6E+01	
Selenium	μg/l	1	12	3.0E+00	3.0E+00	3.0E+00		
Silica	mg/l	10	10	3.5E+01	5.6E+01	7.8E+01	9.0E+01	

**TABLE C-7.—Groundwater Detection Statistics by Watershed and by Analyte
(Environmental Surveillance Report Data 1991 to 1996)-Continued**

GROUNDWATER REGIME^a	ANALYTE	UNITS^b	DETECTED	ANALYZED	MINIMUM	MEAN	MAXIMUM	95% UCL^c
Pueblo (cont.)	Silver	µg/l	1	12	2.0E+00	2.0E+00	2.0E+00	
	Sodium	mg/l	12	12	6.0E+01	6.5E+01	6.9E+01	7.0E+01
	Sodium-22	pCi/l	4	6	1.0E-01	3.6E+00	1.2E+01	1.5E+01
	Strontium	µg/l	12	12	8.7E+01	1.3E+02	3.0E+02	2.4E+02
	Strontium-90	pCi/l	9	11	2.0E-01	1.5E+00	4.2E+00	4.2E+00
	Sulfate	mg/l	11	11	6.8E+00	1.5E+01	2.7E+01	3.0E+01
	Thallium	µg/l	2	11	2.0E-01	4.0E-01	6.0E-01	9.7E-01
	Total Dissolved Solids	mg/l	10	10	2.4E+02	3.0E+02	4.0E+02	3.9E+02
	Total Suspended Solids	mg/l	1	5	2.4E+00	2.4E+00	2.4E+00	
	Tritium	nCi/l	7	12	1.0E-01	3.4E-01	1.1E+00	1.0E+00
	Turbidity	NTU	4	4	1.5E+00	2.5E+00	5.6E+00	6.6E+00
	Uranium	µg/l	12	12	4.0E-02	6.0E-01	1.8E+00	1.6E+00
	Vanadium	µg/l	8	12	3.4E+00	1.3E+01	3.0E+01	3.2E+01
	Zinc	µg/l	9	12	7.8E+00	5.0E+01	1.6E+02	1.4E+02
Intermediate Perched Groundwater Los Alamos	Aluminum	µg/l	6	7	6.0E+01	3.1E+03	1.5E+04	1.5E+04
	Americium-241	pCi/l	3	6	3.0E-02	6.0E-02	1.1E-01	1.5E-01
	Antimony	µg/l	4	7	4.0E-01	7.5E-01	1.0E+00	1.4E+00
	Arsenic	µg/l	6	7	3.0E+00	6.0E+00	1.3E+01	1.3E+01
	Barium	µg/l	6	6	4.8E+01	9.0E+01	1.7E+02	1.8E+02
	Beryllium	µg/l	1	7	3.0E+00	3.0E+00	3.0E+00	
	Bicarbonate	mg/l	7	7	5.3E+01	9.1E+01	1.2E+02	1.5E+02
	Boron	µg/l	7	7	6.3E+01	1.5E+02	2.7E+02	3.3E+02
	Bromine	µg/l	1	1	8.0E+01	8.0E+01	8.0E+01	
Cadmium	µg/l	1	7	5.0E+00	5.0E+00	5.0E+00		

**TABLE C-7.—Groundwater Detection Statistics by Watershed and by Analyte
(Environmental Surveillance Report Data 1991 to 1996)-Continued**

GROUNDWATER REGIME^a	ANALYTE	UNITS^b	DETECTED	ANALYZED	MINIMUM	MEAN	MAXIMUM	95% UCL^c
Intermediate Perched Groundwater Los Alamos (cont.)	Calcium	mg/l	7	7	1.2E+01	2.6E+01	3.7E+01	4.2E+01
	Cesium-137	pCi/l	4	7	1.2E+00	4.9E+00	1.3E+01	1.6E+01
	Chlorine	mg/l	7	7	2.1E+01	3.6E+01	6.1E+01	6.4E+01
	Chloroethane	μg/l	1	2	2.1E+01	2.1E+01	2.1E+01	
	Chromium	μg/l	3	7	1.5E+00	3.2E+00	5.0E+00	6.7E+00
	Cobalt	μg/l	1	7	1.5E+01	1.5E+01	1.5E+01	
	Copper	μg/l	5	7	3.0E+00	1.3E+01	3.0E+01	3.5E+01
	Cyanide	mg/l	1	5	2.3E-02	2.3E-02	2.3E-02	
	Fluorine	mg/l	7	7	3.0E-01	4.5E-01	8.0E-01	7.9E-01
	Gross Alpha	pCi/l	5	7	1.0E+00	2.5E+00	4.0E+00	5.4E+00
	Gross Beta	pCi/l	7	7	5.0E+00	1.4E+01	5.2E+01	4.8E+01
	Gross Gamma	pCi/l	6	7	2.0E+01	6.2E+01	1.9E+02	1.9E+02
	Hardness	mg/l	7	7	4.3E+01	8.7E+01	1.3E+02	1.4E+02
	Iron	μg/l	7	7	3.0E+01	1.9E+03	1.1E+04	1.0E+04
	Lead	μg/l	5	8	1.0E+00	7.4E+00	2.8E+01	3.1E+01
	Magnesium	mg/l	7	7	3.1E+00	6.1E+00	9.4E+00	1.1E+01
	Manganese	μg/l	6	7	1.7E+01	2.6E+02	6.8E+02	8.9E+02
	Mercury	μg/l	3	7	1.0E-01	4.3E-01	8.0E-01	1.1E+00
	Molybdenum	μg/l	5	7	3.0E+00	3.0E+01	6.9E+01	9.6E+01
	Nickel	μg/l	1	7	3.4E+01	3.4E+01	3.4E+01	
Nitrate, as Nitrogen	mg/l	8	8	5.0E-01	4.7E+00	1.5E+01	1.5E+01	
Nitrite, as Nitrogen	mg/l	1	1	9.2E-01	9.2E-01	9.2E-01		
pH			7	7	6.7E+00		8.3E+00	
Phoisphate	mg/l	6	6	2.0E-01	2.6E+00	6.9E+00	7.8E+00	
Phosphate	mg/l	1	1	5.7E+00	5.7E+00	5.7E+00		

**TABLE C-7.—Groundwater Detection Statistics by Watershed and by Analyte
(Environmental Surveillance Report Data 1991 to 1996)-Continued**

GROUNDWATER REGIME^a	ANALYTE	UNITS^b	DETECTED	ANALYZED	MINIMUM	MEAN	MAXIMUM	95% UCL^c
Intermediate Perched Groundwater Los Alamos (cont.)	Plutonium-238	pCi/l	4	7	1.2E-02	1.7E-02	3.0E-02	3.4E-02
	Plutonium-239, Plutonium-240	pCi/l	6	7	1.4E-02	5.6E-02	1.4E-01	1.5E-01
	Potassium	mg/l	6	6	4.0E+00	8.0E+00	1.2E+01	1.4E+01
	Silica	mg/l	8	8	3.9E+01	5.8E+01	8.1E+01	8.5E+01
	Silver	µg/l	1	7	1.0E+00	1.0E+00	1.0E+00	
	Sodium	mg/l	7	7	2.7E+01	4.2E+01	6.7E+01	7.1E+01
	Strontium	µg/l	7	7	6.0E+01	1.4E+02	2.0E+02	2.5E+02
	Strontium-90	pCi/l	5	6	4.0E-01	4.6E+00	2.1E+01	2.3E+01
	Sulfate	mg/l	7	7	8.0E+00	1.9E+01	3.4E+01	3.7E+01
	Thallium	µg/l	2	7	4.0E-02	2.2E-01	4.0E-01	7.3E-01
	Total Dissolved Solids	mg/l	7	7	2.4E+02	3.1E+02	3.8E+02	4.1E+02
	Total Suspended Solids	mg/l	2	2	3.7E+00	1.7E+01	3.0E+01	5.4E+01
	Tritium	nCi/l	6	7	2.0E-01	6.8E-01	2.0E+00	2.1E+00
	Uranium	µg/l	7	7	5.9E-01	1.3E+00	3.3E+00	3.4E+00
	Vanadium	µg/l	7	7	7.0E+00	1.5E+01	3.0E+01	3.1E+01
Zinc	µg/l	4	7	1.0E+01	3.6E+01	8.2E+01	9.9E+01	
Pueblo	Aluminum	µg/l	3	12	4.0E+01	1.0E+02	2.3E+02	3.2E+02
	Americium-241	pCi/l	5	7	1.1E-02	3.5E-02	6.5E-02	8.8E-02
	Antimony	µg/l	3	12	1.0E-01	4.5E+01	1.3E+02	2.0E+02
	Arsenic	µg/l	4	12	2.0E+00	4.4E+00	7.0E+00	9.0E+00
	Barium	µg/l	8	10	3.0E+01	4.7E+01	8.2E+01	8.6E+01
	Bicarbonate	mg/l	12	12	6.8E+01	1.0E+02	1.6E+02	1.6E+02
	Boron	µg/l	11	12	3.0E+01	1.5E+02	2.3E+02	2.8E+02

**TABLE C-7.—Groundwater Detection Statistics by Watershed and by Analyte
(Environmental Surveillance Report Data 1991 to 1996)-Continued**

GROUNDWATER REGIME^a	ANALYTE	UNITS^b	DETECTED	ANALYZED	MINIMUM	MEAN	MAXIMUM	95% UCL^c
Pueblo (cont.)	Cadmium	µg/l	3	12	4.0E-01	5.9E+00	1.0E+01	1.6E+01
	Calcium	mg/l	12	12	1.0E+01	2.8E+01	3.8E+01	4.7E+01
	Cesium-137	pCi/l	8	12	3.2E-01	1.0E+01	5.6E+01	4.9E+01
	Chlorine	mg/l	12	12	4.6E+00	3.7E+01	6.0E+01	6.9E+01
	Chromium	µg/l	2	12	1.6E+00	4.0E+00	6.4E+00	1.1E+01
	Cobalt	µg/l	1	12	9.0E+00	9.0E+00	9.0E+00	
	Copper	µg/l	4	12	8.0E+00	3.3E+01	5.5E+01	7.7E+01
	Fluorine	mg/l	12	12	2.0E-01	4.9E-01	9.0E-01	1.0E+00
	Gross Alpha	pCi/l	4	12	1.0E+00	1.5E+00	2.0E+00	2.7E+00
	Gross Beta	pCi/l	12	12	1.2E+00	5.2E+00	9.0E+00	1.0E+01
	Gross Gamma	pCi/l	9	12	1.0E+01	1.0E+02	2.4E+02	2.4E+02
	Hardness	mg/l	12	12	3.3E+01	9.6E+01	1.2E+02	1.6E+02
	Iron	µg/l	12	12	4.5E+02	7.9E+03	5.7E+04	4.1E+04
	Lead	µg/l	10	14	4.6E+00	3.6E+01	9.1E+01	1.1E+02
	Lithium	mg/l	2	2	1.3E-02	2.4E-02	3.5E-02	5.5E-02
	Magnesium	mg/l	12	12	1.8E+00	6.7E+00	8.6E+00	1.0E+01
	Manganese	µg/l	12	12	5.6E+01	1.2E+02	2.0E+02	2.1E+02
	Mercury	µg/l	3	12	2.0E-01	3.7E-01	7.0E-01	9.4E-01
	Molybdenum	µg/l	5	12	5.0E+00	8.8E+00	1.5E+01	1.6E+01
	Nickel	µg/l	2	12	2.0E+01	3.1E+01	4.1E+01	6.0E+01
	Nitrate, as Nitrogen	mg/l	10	12	9.0E-02	6.0E+00	1.9E+01	1.8E+01
	pH			6	6	7.1E+00		8.6E+00
Phosphate, as Phosphorous	mg/l	9	10	1.0E-01	1.2E+00	4.1E+00	4.1E+00	
Plutonium-238	pCi/l	5	15	3.0E-03	8.2E-03	1.9E-02	2.1E-02	

**TABLE C-7.—Groundwater Detection Statistics by Watershed and by Analyte
(Environmental Surveillance Report Data 1991 to 1996)-Continued**

GROUNDWATER REGIME^a	ANALYTE	UNITS^b	DETECTED	ANALYZED	MINIMUM	MEAN	MAXIMUM	95% UCL^c
Pueblo (cont.)	Plutonium-239, Plutonium-240	pCi/l	9	15	7.0E-03	1.6E-01	1.3E+00	1.0E+00
	Potassium	mg/l	11	12	1.6E+00	4.9E+00	9.6E+00	9.7E+00
	Selenium	µg/l	1	12	2.0E+00	2.0E+00	2.0E+00	
	Silica	mg/l	11	12	7.0E+00	4.3E+01	6.8E+01	8.3E+01
	Sodium	mg/l	12	12	1.8E+01	4.3E+01	8.8E+01	8.6E+01
	Strontium	µg/l	11	12	3.3E+01	1.5E+02	2.1E+02	2.7E+02
	Strontium-90	pCi/l	5	8	1.0E-01	4.6E-01	7.0E-01	9.6E-01
	Sulfate	mg/l	11	12	7.3E+00	2.2E+01	3.1E+01	3.6E+01
	Thallium	µg/l	2	12	1.0E-01	6.0E-01	1.1E+00	2.0E+00
	Tin	µg/l	1	10	7.0E+01	7.0E+01	7.0E+01	
	Total Dissolved Solids	mg/l	10	12	1.8E+02	2.6E+02	3.3E+02	3.7E+02
	Total Suspended Solids	mg/l	2	4	7.6E+00	9.3E+00	1.1E+01	1.4E+01
	Tritium	nCi/l	12	12	1.8E-01	1.2E+00	3.1E+00	3.7E+00
	Uranium	µg/l	10	12	8.0E-02	3.7E-01	8.0E-01	8.0E-01
Vanadium	µg/l	3	12	2.0E+00	6.0E+00	1.1E+01	1.5E+01	
Zinc	µg/l	11	12	1.4E+02	3.0E+03	9.5E+03	9.3E+03	

^a Groundwater regime designations are in accordance with the Environmental Surveillance Program.

^b pCi/l is picocuries of radioactive analyte per liter of sample, nCi/l is nanocuries of radioactive analyte per liter, µg/l is micrograms of analyte per liter of sample, mg/l is milligrams of analyte per liter of sample, NTU is nephelometric turbidity units.

^c Upper confidence limit (UCL) not calculated when the number of detected analyses equals 1.

TABLE C-8.—Soil Detection Statistics by Watershed and by Analyte (ER Risk Database [LANL 1998]—Organics)

WATERSHED	ANALYTE NAME	UNITS	DETECTED	ANALYZED	MINIMUM	MEAN	MAXIMUM	UCL
Acid Canyon (Part of Pueblo/ Acid Canyon)	Acenaphthene	mg/kg	1	26	1.8E+00	1.8E+00	1.8E+00	
	Acetone	mg/kg	2	3	3.4E-02	4.0E-02	4.5E-02	5.1E-02
	Anthracene	mg/kg	1	26	2.2E+00	2.2E+00	2.2E+00	
	Benzo(a)anthracene	mg/kg	1	26	2.5E+00	2.5E+00	2.5E+00	
	Benzo(a)pyrene	mg/kg	1	26	2.6E+00	2.6E+00	2.6E+00	
	Benzo(b)fluoranthene	mg/kg	2	26	3.6E-01	1.5E+00	2.7E+00	3.9E+00
	Benzo(g,h,i)perylene	mg/kg	1	26	1.3E+00	1.3E+00	1.3E+00	
	Benzo(k)fluoranthene	mg/kg	1	26	1.0E+00	1.0E+00	1.0E+00	
	Chlordane[alpha-]	mg/kg	1	2	5.0E-03	5.0E-03	5.0E-03	
	Chlordane[gamma-]	mg/kg	1	2	6.6E-03	6.6E-03	6.6E-03	
	Chrysene	mg/kg	1	26	2.3E+00	2.3E+00	2.3E+00	
	DDT[4,4' -]	mg/kg	1	2	2.2E-02	2.2E-02	2.2E-02	
	Dibenzofuran	mg/kg	1	26	1.6E+00	1.6E+00	1.6E+00	
	Dieldrin	mg/kg	1	2	4.7E-03	4.7E-03	4.7E-03	
	Fluoranthene	mg/kg	1	26	5.2E+00	5.2E+00	5.2E+00	
	Fluorene	mg/kg	1	26	2.7E+00	2.7E+00	2.7E+00	
	Indeno(1,2,3-cd) pyrene	mg/kg	1	26	1.2E+00	1.2E+00	1.2E+00	
	Methylene Chloride	mg/kg	1	3	7.0E-03	7.0E-03	7.0E-03	
	Methylnaphthalene[2-]	mg/kg	1	26	2.3E+00	2.3E+00	2.3E+00	
	Naphthalene	mg/kg	1	29	8.5E+00	8.5E+00	8.5E+00	
Phenanthrene	mg/kg	1	26	7.6E+00	7.6E+00	7.6E+00		
Pyrene	mg/kg	4	26	3.8E-01	1.5E+00	4.7E+00	3.7E+00	
Ancho Canyon	Acenaphthene	mg/kg	12	279	3.3E-02	2.7E+00	1.0E+01	4.5E+00
	Amino-2,6- dinitrotoluene[4-]	mg/kg	3	242	9.7E-02	2.4E-01	4.5E-01	4.6E-01

TABLE C-8.—Soil Detection Statistics by Watershed and by Analyte (ER Risk Database [LANL 1998]—Organics)-Continued

WATERSHED	ANALYTE NAME	UNITS	DETECTED	ANALYZED	MINIMUM	MEAN	MAXIMUM	UCL
Ancho Canyon (Cont.)	Amino-4,6-dinitrotoluene[2-]	mg/kg	2	242	4.3E-01	4.9E-01	5.5E-01	6.2E-01
	Anthracene	mg/kg	16	279	6.6E-02	3.4E+00	1.6E+01	5.7E+00
	Aroclor-1016	mg/kg	4	96	1.8E-01	3.1E-01	7.0E-01	5.7E-01
	Aroclor-1221	mg/kg	4	96	3.5E-01	6.2E-01	1.4E+00	1.1E+00
	Aroclor-1232	mg/kg	4	96	1.8E-01	3.1E-01	7.0E-01	5.7E-01
	Aroclor-1242	mg/kg	14	144	1.8E-01	2.3E+02	3.1E+03	6.7E+02
	Aroclor-1248	mg/kg	13	96	3.6E-02	2.0E+00	2.1E+01	5.1E+00
	Aroclor-1254	mg/kg	32	144	3.7E-02	1.5E+00	2.2E+01	3.1E+00
	Aroclor-1260	mg/kg	14	144	3.6E-02	1.5E+00	7.4E+00	2.5E+00
	Aroclors (Mixed)	mg/kg	16	64	3.7E-02	2.0E+02	3.1E+03	5.9E+02
	Benzo(a)anthracene	mg/kg	19	279	2.3E-01	6.1E+00	3.2E+01	1.0E+01
	Benzo(a)pyrene	mg/kg	21	279	1.6E-01	5.8E+00	2.9E+01	9.2E+00
	Benzo(b)fluoranthene	mg/kg	23	279	2.0E-01	5.7E+00	3.5E+01	9.5E+00
	Benzo(g,h,i)perylene	mg/kg	22	279	1.3E-01	2.2E+00	9.6E+00	3.4E+00
	Benzo(k)fluoranthene	mg/kg	21	279	2.0E-01	2.7E+00	1.1E+01	3.9E+00
	Benzoic Acid	mg/kg	5	279	4.9E-02	5.7E-01	1.1E+00	9.3E-01
	Bis(2-ethylhexyl) phthalate	mg/kg	21	279	3.8E-02	5.4E-01	1.7E+00	7.4E-01
	Butylbenzylphthalate	mg/kg	1	279	2.2E-01	2.2E-01	2.2E-01	
	Chrysene	mg/kg	23	279	1.8E-01	5.7E+00	3.3E+01	9.5E+00
	DDD[4,4' -]	mg/kg	1	42	1.1E-02	1.1E-02	1.1E-02	
	DDE[4,4' -]	mg/kg	1	42	7.9E-02	7.9E-02	7.9E-02	
	DDT[4,4' -]	mg/kg	2	42	5.5E-03	1.0E-02	1.5E-02	2.0E-02
	Di-n-butylphthalate	mg/kg	26	279	3.6E-02	2.4E+00	1.3E+01	3.9E+00
	Di-n-octylphthalate	mg/kg	1	279	4.5E+00	4.5E+00	4.5E+00	
	Dibenz(a,h)anthracene	mg/kg	7	279	3.3E-02	2.0E+00	4.0E+00	3.3E+00
	Dibenzofuran	mg/kg	8	279	4.1E-01	1.8E+00	5.6E+00	3.0E+00

TABLE C-8.—*Soil Detection Statistics by Watershed and by Analyte (ER Risk Database [LANL 1998]—Organics)-Continued*

WATERSHED	ANALYTE NAME	UNITS	DETECTED	ANALYZED	MINIMUM	MEAN	MAXIMUM	UCL
Ancho Canyon (Cont.)	Fluorene	mg/kg	12	279	3.6E-01	2.8E+00	1.0E+01	4.7E+00
	HMX	mg/kg	4	242	1.3E+00	1.2E+01	2.5E+01	2.3E+01
	Indeno(1,2,3-cd) pyrene	mg/kg	20	279	1.3E-01	3.9E+00	1.7E+01	6.4E+00
	Methylnaphthalene[2-]	mg/kg	5	279	4.0E-01	7.5E-01	1.1E+00	1.0E+00
	Naphthalene	mg/kg	10	279	1.7E-01	2.7E+00	8.4E+00	4.4E+00
	Nitrotoluene[2-]	mg/kg	3	242	7.9E-01	1.4E+00	1.9E+00	2.1E+00
	Nitrotoluene[3-]	mg/kg	3	242	6.0E-01	2.0E+00	4.8E+00	4.8E+00
	Nitrotoluene[4-]	mg/kg	2	242	3.2E+00	4.3E+00	5.4E+00	6.5E+00
	Phenanthrene	mg/kg	21	279	3.0E-01	1.4E+01	7.9E+01	2.4E+01
	Pyrene	mg/kg	23	279	4.3E-01	1.2E+01	7.3E+01	2.0E+01
	RDX	mg/kg	1	242	9.2E+00	9.2E+00	9.2E+00	9.2E+00
	Tetryl	mg/kg	3	242	3.5E-01	9.7E-01	2.0E+00	2.0E+00
	Trinitrobenzene[1,3,5-]	mg/kg	3	242	3.1E-01	3.1E+00	8.0E+00	8.0E+00
	Trinitrotoluene[2,4,6-]	mg/kg	1	242	1.0E+00	1.0E+00	1.0E+00	
Barrancas Canyon	Amino-2,6- dinitrotoluene[4-]	mg/kg	1	8	1.6E-01	1.6E-01	1.6E-01	
	Dinitrotoluene[2,6-]	mg/kg	1	8	7.9E-01	7.9E-01	7.9E-01	
	HMX	mg/kg	1	8	1.6E+00	1.6E+00	1.6E+00	
	Nitrobenzene	mg/kg	2	8	1.0E-01	1.3E-01	1.5E-01	1.8E-01
	Nitrotoluene[2-]	mg/kg	1	8	2.1E-01	2.1E-01	2.1E-01	
	Nitrotoluene[3-]	mg/kg	1	8	4.4E-01	4.4E-01	4.4E-01	
	Nitrotoluene[4-]	mg/kg	1	8	4.7E-01	4.7E-01	4.7E-01	
Bayo Canyon	Nitrobenzene	mg/kg	1	36	9.8E-02	9.8E-02	9.8E-02	
	Nitrotoluene[3-]	mg/kg	2	28	2.1E-01	2.1E-01	2.1E-01	2.1E-01

TABLE C-8.—Soil Detection Statistics by Watershed and by Analyte (ER Risk Database [LANL 1998]—Organics)-Continued

WATERSHED	ANALYTE NAME	UNITS	DETECTED	ANALYZED	MINIMUM	MEAN	MAXIMUM	UCL
Cañada del Buey	Acenaphthene	mg/kg	10	172	4.5E-01	2.6E+00	7.8E+00	4.4E+00
	Acenaphthylene	mg/kg	3	172	6.3E-01	1.9E+00	2.8E+00	3.2E+00
	Acetone	mg/kg	2	80	4.1E-02	2.3E-01	4.2E-01	6.1E-01
	Aldrin	mg/kg	1	74	4.9E-02	4.9E-02	4.9E-02	
	Anthracene	mg/kg	16	172	4.1E-01	2.4E+00	1.3E+01	4.1E+00
	Aroclor-1254	mg/kg	10	159	7.0E-02	4.6E+00	2.2E+01	1.0E+01
	Aroclor-1260	mg/kg	4	159	4.3E-02	1.7E-01	3.7E-01	3.2E-01
	Aroclors (Mixed)	mg/kg	2	85	7.0E-02	1.1E+01	2.2E+01	3.2E+01
	BHC[alpha-]	mg/kg	1	74	4.0E-03	4.0E-03	4.0E-03	
	BHC[delta-]	mg/kg	1	74	1.6E-01	1.6E-01	1.6E-01	
	BHC[gamma-]	mg/kg	3	74	2.8E-03	3.1E-02	8.2E-02	8.2E-02
	Benzo(a)anthracene	mg/kg	36	172	3.6E-01	2.4E+00	1.7E+01	3.6E+00
	Benzo(a)pyrene	mg/kg	33	172	4.7E-01	2.3E+00	1.6E+01	3.3E+00
	Benzo(b)fluoranthene	mg/kg	38	172	4.1E-01	3.3E+00	2.1E+01	4.8E+00
	Benzo(g,h,i)perylene	mg/kg	16	172	4.3E-01	1.9E+00	1.1E+01	3.2E+00
	Benzo(k)fluoranthene	mg/kg	22	172	4.1E-01	2.9E+00	2.8E+01	5.4E+00
	Bis(2-ethylhexyl) phthalate	mg/kg	24	172	3.7E-01	1.4E+00	4.4E+00	1.8E+00
	Butylbenzylphthalate	mg/kg	4	172	4.3E-01	1.1E+00	2.9E+00	2.3E+00
	Chrysene	mg/kg	40	172	3.6E-01	2.8E+00	2.6E+01	4.5E+00
	DDD[4,4' -]	mg/kg	2	74	4.5E-03	1.3E-02	2.1E-02	2.9E-02
	DDE[4,4' -]	mg/kg	6	74	6.2E-03	2.4E-02	8.4E-02	4.9E-02
	DDT[4,4' -]	mg/kg	8	74	6.1E-03	1.5E-02	4.9E-02	2.5E-02
	Di-n-butylphthalate	mg/kg	6	172	4.4E-01	1.1E+00	1.8E+00	1.6E+00
	Di-n-octylphthalate	mg/kg	1	172	7.4E-01	7.4E-01	7.4E-01	
	Dibenz(a,h)anthracene	mg/kg	5	172	4.5E-01	1.9E+00	4.8E+00	3.6E+00
	Dibenzofuran	mg/kg	7	172	4.5E-01	3.2E+00	1.2E+01	6.4E+00

TABLE C-8.—*Soil Detection Statistics by Watershed and by Analyte (ER Risk Database [LANL 1998]—Organics)-Continued*

WATERSHED	ANALYTE NAME	UNITS	DETECTED	ANALYZED	MINIMUM	MEAN	MAXIMUM	UCL
Cañada del Buey (Cont.)	Dieldrin	mg/kg	15	75	7.9E-04	1.2E-02	1.1E-01	2.6E-02
	Endosulfan II	mg/kg	9	74	2.5E-03	9.2E-03	2.1E-02	1.4E-02
	Endosulfan Sulfate	mg/kg	2	75	1.8E-03	1.9E-03	2.0E-03	2.1E-03
	Endrin	mg/kg	6	74	2.3E-03	1.1E-02	2.7E-02	1.8E-02
	Endrin Aldehyde	mg/kg	6	74	3.1E-03	3.9E-02	1.8E-01	9.5E-02
	Fluoranthene	mg/kg	52	172	3.7E-01	6.3E+00	7.4E+01	1.0E+01
	Fluorene	mg/kg	8	172	4.7E-01	3.5E+00	1.1E+01	6.4E+00
	Heptachlor	mg/kg	1	75	2.8E-02	2.8E-02	2.8E-02	
	Heptachlor Epoxide	mg/kg	6	75	3.0E-03	6.8E-03	1.5E-02	1.0E-02
	Indeno(1,2,3-cd)pyrene	mg/kg	20	172	3.6E-01	2.0E+00	1.1E+01	3.4E+00
	Isopropyltoluene[4-]	mg/kg	1	80	3.5E-02	3.5E-02	3.5E-02	
	Methoxychlor[4,4'-]	mg/kg	7	75	2.6E-02	4.0E+01	2.8E+02	1.2E+02
	Methylene Chloride	mg/kg	7	80	6.8E-03	1.4E-02	5.1E-02	2.7E-02
	Methylnaphthalene[2-]	mg/kg	4	172	4.3E-01	3.8E+00	9.8E+00	7.9E+00
	Methylphenol[4-]	mg/kg	2	172	5.4E-01	8.7E-01	1.2E+00	1.5E+00
	Naphthalene	mg/kg	8	179	4.7E-01	8.0E+00	3.9E+01	1.7E+01
	Phenanthrene	mg/kg	44	172	3.8E-01	6.8E+00	8.3E+01	1.2E+01
	Phenol	mg/kg	1	172	5.6E-01	5.6E-01	5.6E-01	
	Pyrene	mg/kg	49	172	3.8E-01	5.8E+00	6.2E+01	9.0E+00
	Trichloro-1,2,2-trifluoroethane[1,1,2-]	mg/kg	2	80	6.0E-03	1.5E+00	3.0E+00	4.5E+00
	Trichloroethane[1,1,1-]	mg/kg	2	80	7.0E-03	1.1E+01	2.1E+01	3.1E+01
	Trichloroethene	mg/kg	2	80	2.1E-02	6.6E-01	1.3E+00	1.9E+00
	Trichlorofluoromethane	mg/kg	1	80	6.0E-03	6.0E-03	6.0E-03	
Chaquehui Canyon	Acenaphthene	mg/kg	20	235	4.5E-02	1.2E+00	1.3E+01	2.5E+00
	Acenaphthylene	mg/kg	1	235	4.9E-01	4.9E-01	4.9E-01	
	Aldrin	mg/kg	2	34	2.9E-02	3.6E-02	4.2E-02	4.9E-02

TABLE C-8.—Soil Detection Statistics by Watershed and by Analyte (ER Risk Database [LANL 1998]—Organics)-Continued

WATERSHED	ANALYTE NAME	UNITS	DETECTED	ANALYZED	MINIMUM	MEAN	MAXIMUM	UCL
Chaquehui Canyon (Cont.)	Amino-2,6-dinitrotoluene[4-]	mg/kg	3	92	3.6E-01	2.1E+00	5.4E+00	5.4E+00
	Amino-4,6-dinitrotoluene[2-]	mg/kg	3	98	3.6E-01	2.1E+00	5.4E+00	5.4E+00
	Aniline	mg/kg	1	193	4.1E-01	4.1E-01	4.1E-01	
	Anthracene	mg/kg	24	235	1.8E-01	1.7E+00	1.9E+01	3.2E+00
	Aroclor-1016	mg/kg	4	41	3.4E-02	1.5E+00	3.6E+00	3.1E+00
	Aroclor-1221	mg/kg	4	41	6.7E-02	3.1E+00	7.2E+00	6.2E+00
	Aroclor-1232	mg/kg	4	41	3.4E-02	1.5E+00	3.6E+00	3.1E+00
	Aroclor-1242	mg/kg	4	45	3.4E-02	1.5E+00	3.6E+00	3.1E+00
	Aroclor-1248	mg/kg	4	41	3.4E-02	1.5E+00	3.6E+00	3.1E+00
	Aroclor-1254	mg/kg	21	48	3.4E-02	9.1E-01	3.6E+00	1.3E+00
	Aroclor-1260	mg/kg	12	48	7.0E-02	2.7E+00	1.1E+01	4.7E+00
	Aroclors (Mixed)	mg/kg	8	19	1.0E-01	8.2E-01	2.3E+00	1.4E+00
	Azobenzene	mg/kg	1	193	4.3E-01	4.3E-01	4.3E-01	
	BHC[alpha-]	mg/kg	2	34	2.7E-02	3.4E-02	4.1E-02	4.8E-02
	BHC[beta-]	mg/kg	2	34	2.3E-03	2.4E-03	2.4E-03	2.5E-03
	BHC[delta-]	mg/kg	2	34	2.6E-02	3.2E-02	3.7E-02	4.3E-02
	Benzo(a)anthracene	mg/kg	42	235	5.2E-02	2.0E+00	2.7E+01	3.3E+00
	Benzo(a)pyrene	mg/kg	37	235	7.4E-02	2.2E+00	2.9E+01	3.8E+00
	Benzo(b)fluoranthene	mg/kg	43	235	6.4E-02	2.4E+00	2.8E+01	3.8E+00
	Benzo(g,h,i)perylene	mg/kg	27	235	5.5E-02	1.3E+00	1.3E+01	2.3E+00
	Benzo(k)fluoranthene	mg/kg	30	230	6.3E-02	2.5E+00	2.1E+01	4.0E+00
	Benzoic Acid	mg/kg	2	235	2.0E-01	2.1E-01	2.2E-01	2.3E-01
	Bis(2-ethylhexyl) phthalate	mg/kg	15	235	4.5E-02	9.9E-01	3.2E+00	1.4E+00
	Butylbenzylphthalate	mg/kg	4	235	4.4E-01	6.9E-01	9.8E-01	9.3E-01
	Carbazole	mg/kg	5	16	1.9E-01	1.0E+00	3.0E+00	2.0E+00

TABLE C-8.—*Soil Detection Statistics by Watershed and by Analyte (ER Risk Database [LANL 1998]—Organics)-Continued*

WATERSHED	ANALYTE NAME	UNITS	DETECTED	ANALYZED	MINIMUM	MEAN	MAXIMUM	UCL
Chaquehui Canyon (Cont.)	Chrysene	mg/kg	46	235	6.4E-02	2.0E+00	2.9E+01	3.4E+00
	DDD[4,4'-]	mg/kg	2	34	7.5E-03	9.8E-03	1.2E-02	1.4E-02
	DDE[4,4'-]	mg/kg	6	34	1.4E-03	1.9E-03	2.4E-03	2.2E-03
	DDT[4,4'-]	mg/kg	6	34	4.4E-03	1.0E-02	2.3E-02	1.6E-02
	D[2,4-]	mg/kg	2	51	1.9E+00	2.1E+00	2.3E+00	2.5E+00
	Di-n-butylphthalate	mg/kg	21	235	3.4E-02	1.2E+00	4.8E+00	1.9E+00
	Dibenz(a,h)anthracene	mg/kg	8	235	8.3E-02	9.3E-01	4.7E+00	2.0E+00
	Dibenzofuran	mg/kg	9	235	4.6E-02	9.7E-01	5.6E+00	2.1E+00
	Dichlorobenzene[1,4-]	mg/kg	1	238	1.8E-01	1.8E-01	1.8E-01	
	Dieldrin	mg/kg	2	34	7.0E-04	7.7E-04	8.3E-04	9.0E-04
	Diethylphthalate	mg/kg	1	235	3.0E+01	3.0E+01	3.0E+01	
	Dimethylphenol[2,4-]	mg/kg	1	235	7.0E-01	7.0E-01	7.0E-01	
	Dinitrotoluene[2,4-]	mg/kg	1	364	2.0E+00	2.0E+00	2.0E+00	
	Dinoseb	mg/kg	1	51	6.9E-01	6.9E-01	6.9E-01	
	Endosulfan I	mg/kg	1	34	6.1E-03	6.1E-03	6.1E-03	
	Endosulfan II	mg/kg	6	34	2.0E-03	4.4E-03	1.1E-02	7.2E-03
	Endosulfan Sulfate	mg/kg	1	34	1.8E-02	1.8E-02	1.8E-02	
	Endrin	mg/kg	2	34	2.3E-03	2.5E-03	2.7E-03	2.9E-03
	Endrin Aldehyde	mg/kg	1	26	8.7E-03	8.7E-03	8.7E-03	
	Fluoranthene	mg/kg	63	235	4.2E-02	2.7E+00	5.4E+01	4.5E+00
	Fluorene	mg/kg	14	235	8.8E-02	1.6E+00	1.5E+01	3.7E+00
	Indeno(1,2,3-cd)pyrene	mg/kg	30	235	5.0E-02	1.4E+00	1.4E+01	2.4E+00
	Methylene Chloride	mg/kg	2	3	4.2E-03	4.6E-03	5.0E-03	5.4E-03
	Methylnaphthalene[2-]	mg/kg	4	235	4.9E-02	2.6E+00	9.3E+00	7.1E+00
	Methylphenol[2-]	mg/kg	1	235	3.7E-01	3.7E-01	3.7E-01	
	Methylphenol[4-]	mg/kg	1	235	9.8E-01	9.8E-01	9.8E-01	
	Naphthalene	mg/kg	14	237	6.0E-02	2.6E+00	2.7E+01	6.3E+00

TABLE C-8.—Soil Detection Statistics by Watershed and by Analyte (ER Risk Database [LANL 1998]—Organics)-Continued

WATERSHED	ANALYTE NAME	UNITS	DETECTED	ANALYZED	MINIMUM	MEAN	MAXIMUM	UCL
Chaquehui Canyon (Cont.)	Nitrobenzene	mg/kg	2	364	2.5E-01	3.8E-01	5.1E-01	6.4E-01
	Nitrotoluene[2-]	mg/kg	1	123	1.6E-01	1.6E-01	1.6E-01	
	Nitrotoluene[3-]	mg/kg	1	123	5.1E-01	5.1E-01	5.1E-01	
	Nitrotoluene[4-]	mg/kg	1	123	5.1E-01	5.1E-01	5.1E-01	
	Phenanthrene	mg/kg	49	235	6.4E-02	3.5E+00	6.7E+01	6.3E+00
	Pyrene	mg/kg	68	235	1.1E-01	3.3E+00	5.1E+01	5.3E+00
	Pyridine	mg/kg	1	16	1.6E+00	1.6E+00	1.6E+00	
	RDX	mg/kg	2	129	5.0E-01	5.2E-01	5.4E-01	5.6E-01
	Tetryl	mg/kg	1	129	6.9E-01	6.9E-01	6.9E-01	
	Trinitrobenzene[1,3,5-]	mg/kg	1	129	1.7E-01	1.7E-01	1.7E-01	
Trinitrotoluene[2,4,6-]	mg/kg	1	129	2.7E-01	2.7E-01	2.7E-01		
DP Canyon (Part of Los Alamos Canyon)	Acenaphthene	mg/kg	6	665	3.5E-01	2.5E+00	1.1E+01	5.9E+00
	Acenaphthylene	mg/kg	1	665	3.5E-01	3.5E-01	3.5E-01	
	Acetone	mg/kg	46	223	6.3E-03	3.2E-02	2.1E-01	4.1E-02
	Anthracene	mg/kg	7	665	3.4E-01	3.6E+00	2.1E+01	9.4E+00
	Aroclor-1254	mg/kg	1	36	1.1E+00	1.1E+00	1.1E+00	
	Aroclor-1260	mg/kg	19	36	7.0E-02	1.7E+00	1.7E+01	3.4E+00
	Aroclors (Mixed)	mg/kg	18	26	7.0E-02	1.8E+00	1.7E+01	3.6E+00
	Benzene	mg/kg	1	223	3.0E+00	3.0E+00	3.0E+00	
	Benzo(a)anthracene	mg/kg	21	665	4.4E-02	5.5E+00	9.8E+01	1.5E+01
	Benzo(a)pyrene	mg/kg	16	665	2.2E-01	5.6E+00	7.4E+01	1.5E+01
	Benzo(b)fluoranthene	mg/kg	35	665	9.2E-02	3.0E+00	7.6E+01	7.3E+00
	Benzo(g,h,i)perylene	mg/kg	9	664	1.4E-01	4.7E+00	3.7E+01	1.3E+01
	Benzo(k)fluoranthene	mg/kg	12	664	5.3E-02	6.3E+00	6.6E+01	1.7E+01
	Benzoic Acid	mg/kg	5	665	3.6E-01	2.1E+00	3.7E+00	3.2E+00
	Benzyl Alcohol	mg/kg	1	665	7.0E-01	7.0E-01	7.0E-01	
Bis(2-chloroethoxy) methane	mg/kg	1	664	3.5E-01	3.5E-01	3.5E-01		

TABLE C-8.—Soil Detection Statistics by Watershed and by Analyte (ER Risk Database [LANL 1998]—Organics)-Continued

WATERSHED	ANALYTE NAME	UNITS	DETECTED	ANALYZED	MINIMUM	MEAN	MAXIMUM	UCL
DP Canyon (Part of Los Alamos Canyon) (Cont.)	Bis(2-chloroethyl)ether	mg/kg	1	665	3.5E-01	3.5E-01	3.5E-01	
	Bis(2-ethylhexyl) phthalate	mg/kg	29	665	6.4E-02	4.2E+00	6.2E+01	8.5E+00
	Bromophenyl- phenylether[4-]	mg/kg	1	665	3.5E-01	3.5E-01	3.5E-01	
	Butanone[2-]	mg/kg	1	223	6.3E-02	6.3E-02	6.3E-02	
	Butylbenzylphthalate	mg/kg	2	665	3.5E-01	4.3E-01	5.0E-01	5.8E-01
	Carbazole	mg/kg	1	6	3.5E-01	3.5E-01	3.5E-01	
	Carbon Disulfide	mg/kg	2	223	9.2E-03	1.1E-02	1.2E-02	1.3E-02
	Chloro-3-methylphenol [4-]	mg/kg	2	664	7.0E-01	1.8E+00	2.9E+00	4.0E+00
	Chloroaniline[4-]	mg/kg	1	665	7.0E-01	7.0E-01	7.0E-01	
	Chlorobenzene	mg/kg	1	223	2.5E+00	2.5E+00	2.5E+00	
	Chloronaphthalene[1-]	mg/kg	1	6	7.0E-01	7.0E-01	7.0E-01	
	Chloronaphthalene[2-]	mg/kg	1	665	3.5E-01	3.5E-01	3.5E-01	
	Chlorophenol[2-]	mg/kg	2	665	3.5E-01	1.4E+00	2.5E+00	3.6E+00
	Chlorophenyl-phenyl [4-] Ether	mg/kg	1	665	3.5E-01	3.5E-01	3.5E-01	
	Chrysene	mg/kg	24	664	9.3E-02	5.5E+00	1.1E+02	1.5E+01
	DDT[4,4'-]	mg/kg	1	2	2.0E-02	2.0E-02	2.0E-02	
	Di-n-butylphthalate	mg/kg	12	665	5.8E-02	1.0E+00	5.2E+00	1.9E+00
	Di-n-octylphthalate	mg/kg	2	665	3.5E-01	4.6E-01	5.6E-01	6.7E-01
	Dibenz(a,h)anthracene	mg/kg	3	665	3.5E-01	5.7E+00	1.6E+01	1.6E+01
	Dibenzofuran	mg/kg	2	665	3.5E-01	3.1E+00	5.8E+00	8.5E+00
	Dichlorobenzene[1,2-]	mg/kg	1	882	3.5E-01	3.5E-01	3.5E-01	
	Dichlorobenzene[1,3-]	mg/kg	1	881	3.5E-01	3.5E-01	3.5E-01	
	Dichlorobenzene[1,4-]	mg/kg	2	881	3.5E-01	8.8E-01	1.4E+00	1.9E+00
	Dichlorobenzidine [3,3'-]	mg/kg	1	665	7.0E-01	7.0E-01	7.0E-01	

TABLE C-8.—Soil Detection Statistics by Watershed and by Analyte (ER Risk Database [LANL 1998]—Organics)-Continued

WATERSHED	ANALYTE NAME	UNITS	DETECTED	ANALYZED	MINIMUM	MEAN	MAXIMUM	UCL
DP Canyon (Part of Los Alamos Canyon) (Cont.)	Dichlorodifluoro methane	mg/kg	2	216	3.4E-02	3.6E-02	3.8E-02	4.0E-02
	Dichloroethene[1,1-]	mg/kg	1	222	2.9E+00	2.9E+00	2.9E+00	
	Dichlorophenol[2,4-]	mg/kg	1	665	3.5E-01	3.5E-01	3.5E-01	
	Diethylphthalate	mg/kg	4	665	3.5E-01	2.5E+01	9.0E+01	6.8E+01
	Dimethyl Phthalate	mg/kg	1	665	3.5E-01	3.5E-01	3.5E-01	
	Dimethylphenol[2,4-]	mg/kg	1	664	3.5E-01	3.5E-01	3.5E-01	
	Dinitro-2-methylphenol [4,6-]	mg/kg	1	665	1.7E+00	1.7E+00	1.7E+00	
	Dinitrophenol[2,4-]	mg/kg	1	665	1.7E+00	1.7E+00	1.7E+00	
	Dinitrotoluene[2,4-]	mg/kg	2	664	3.5E-01	1.0E+00	1.7E+00	2.4E+00
	Dinitrotoluene[2,6-]	mg/kg	1	658	3.5E-01	3.5E-01	3.5E-01	
	Diphenylamine	mg/kg	1	6	1.1E+00	1.1E+00	1.1E+00	
	Diphenylhydrazine [1,2-]	mg/kg	1	6	1.7E+00	1.7E+00	1.7E+00	
	Fluoranthene	mg/kg	41	664	3.4E-01	9.1E+00	3.2E+02	2.5E+01
	Fluorene	mg/kg	4	665	3.5E-01	3.1E+00	1.1E+01	8.4E+00
	Hexachlorobenzene	mg/kg	1	665	3.5E-01	3.5E-01	3.5E-01	
	Hexachlorobutadiene	mg/kg	1	730	3.5E-01	3.5E-01	3.5E-01	
	Hexachlorocyclopenta diene	mg/kg	1	664	3.5E-01	3.5E-01	3.5E-01	
	Hexachloroethane	mg/kg	1	664	3.5E-01	3.5E-01	3.5E-01	
	Indeno(1,2,3-cd) pyrene”	mg/kg	11	665	1.1E-01	4.0E+00	3.8E+01	1.1E+01
	Isophorone	mg/kg	1	664	3.5E-01	3.5E-01	3.5E-01	
	Isopropyltoluene[4-]	mg/kg	4	217	9.0E-03	1.4E-02	2.5E-02	2.1E-02
Methylene Chloride	mg/kg	8	223	4.7E-03	1.6E-02	5.9E-02	2.8E-02	
Methylnaphthalene[2-]	mg/kg	1	665	3.5E-01	3.5E-01	3.5E-01	3.5E-01	
Methylphenol[2-]	mg/kg	1	665	3.5E-01	3.5E-01	3.5E-01		

TABLE C-8.—*Soil Detection Statistics by Watershed and by Analyte (ER Risk Database [LANL 1998]—Organics)-Continued*

WATERSHED	ANALYTE NAME	UNITS	DETECTED	ANALYZED	MINIMUM	MEAN	MAXIMUM	UCL
DP Canyon (Part of Los Alamos Canyon) (Cont.)	Methylphenol[3-]	mg/kg	1	6	3.5E-01	3.5E-01	3.5E-01	
	Methylphenol[4-]	mg/kg	1	665	3.5E-01	3.5E-01	3.5E-01	
	Naphthalene	mg/kg	2	730	3.5E-01	4.0E-01	4.4E-01	4.9E-01
	Nitroaniline[2-]	mg/kg	1	665	1.7E+00	1.7E+00	1.7E+00	
	Nitroaniline[3-]	mg/kg	1	665	1.7E+00	1.7E+00	1.7E+00	
	Nitroaniline[4-]	mg/kg	1	665	1.7E+00	1.7E+00	1.7E+00	
	Nitrobenzene	mg/kg	1	664	3.5E-01	3.5E-01	3.5E-01	
	Nitrophenol[2-]	mg/kg	1	664	3.5E-01	3.5E-01	3.5E-01	
	Nitrophenol[4-]	mg/kg	2	664	1.7E+00	2.4E+00	3.1E+00	3.8E+00
	Nitroso-di-n-propylamine[N-]	mg/kg	2	665	3.5E-01	9.3E-01	1.5E+00	2.1E+00
	Nitrosodimethylamine [N-]	mg/kg	1	567	3.5E-01	3.5E-01	3.5E-01	
	Nitrosodiphenylamine [N-]	mg/kg	1	665	3.5E-01	3.5E-01	3.5E-01	
	Oxybis(1-chloro propane)[2,2'-]	mg/kg	1	655	3.5E-01	3.5E-01	3.5E-01	
	Pentachlorophenol	mg/kg	2	664	1.7E+00	2.8E+00	3.9E+00	5.0E+00
	Phenanthrene	mg/kg	29	664	5.0E-02	6.7E+00	1.6E+02	1.8E+01
	Phenol	mg/kg	5	665	3.5E-01	1.2E+00	2.6E+00	1.9E+00
	Pyrene	mg/kg	45	665	7.4E-02	6.3E+00	2.3E+02	1.6E+01
	Tetrachloroethene	mg/kg	1	222	6.1E-02	6.1E-02	6.1E-02	
	Toluene	mg/kg	39	223	5.0E-03	8.9E-02	2.6E+00	2.2E-01
	Trichlorobenzene [1,2,4-]	mg/kg	2	730	3.5E-01	9.3E-01	1.5E+00	2.1E+00
Trichloroethene	mg/kg	1	223	2.4E+00	2.4E+00	2.4E+00		
Trichlorofluoromethane	mg/kg	4	216	1.1E-02	1.7E-02	2.6E-02	2.4E-02	

TABLE C-8.—Soil Detection Statistics by Watershed and by Analyte (ER Risk Database [LANL 1998]—Organics)-Continued

WATERSHED	ANALYTE NAME	UNITS	DETECTED	ANALYZED	MINIMUM	MEAN	MAXIMUM	UCL
DP Canyon (Part of Los Alamos Canyon) (Cont.)	Trichlorophenol[2,4,5-]	mg/kg	1	665	3.5E-01	3.5E-01	3.5E-01	
	Trichlorophenol[2,4,6-]	mg/kg	1	665	3.5E-01	3.5E-01	3.5E-01	
	Xylene (Total)	mg/kg	5	222	6.0E-03	1.5E-02	2.1E-02	2.1E-02
Los Alamos Canyon	Acenaphthene	mg/kg	6	259	6.1E-01	1.9E+00	4.6E+00	3.4E+00
	Acetone	mg/kg	1	7	2.5E-02	2.5E-02	2.5E-02	
	Aniline	mg/kg	2	257	4.0E-01	6.6E-01	9.1E-01	1.2E+00
	Anthracene	mg/kg	8	259	6.1E-01	3.5E+00	1.2E+01	6.5E+00
	Aroclor-1254	mg/kg	5	37	1.6E-01	5.8E-01	1.3E+00	9.7E-01
	Aroclor-1260	mg/kg	10	37	7.6E-02	2.4E+00	1.7E+01	5.7E+00
	Aroclors (Mixed)	mg/kg	3	14	1.5E+00	7.5E+00	1.7E+01	1.7E+01
	Benzene	mg/kg	1	7	1.0E-02	1.0E-02	1.0E-02	
	Benzo(a)anthracene	mg/kg	15	259	7.7E-02	3.9E+00	2.3E+01	7.3E+00
	Benzo(a)pyrene	mg/kg	11	259	8.3E-02	3.5E+00	1.6E+01	6.7E+00
	Benzo(b)fluoranthene	mg/kg	27	259	9.6E-02	2.4E+00	1.7E+01	3.9E+00
	Benzo(g,h,i)perylene	mg/kg	7	259	4.4E-01	2.1E+00	6.0E+00	4.0E+00
	Benzo(k)fluoranthene	mg/kg	10	259	8.1E-02	2.7E+00	9.7E+00	4.6E+00
	Benzoic Acid	mg/kg	4	259	8.1E-01	1.7E+00	3.5E+00	3.0E+00
	Bis(2-ethylhexyl) phthalate	mg/kg	7	259	5.5E-02	1.2E+00	5.5E+00	2.7E+00
	Butylbenzylphthalate	mg/kg	3	259	8.2E-02	8.9E-01	1.5E+00	1.7E+00
	Chlordane[alpha-]	mg/kg	1	21	7.2E-03	7.2E-03	7.2E-03	
	Chlordane[gamma-]	mg/kg	1	21	6.8E-03	6.8E-03	6.8E-03	
	Chlorophenol[2-]	mg/kg	1	259	3.7E-01	3.7E-01	3.7E-01	
	Chrysene	mg/kg	19	259	9.6E-02	3.3E+00	1.8E+01	5.5E+00
DDE[4,4'-]	mg/kg	3	21	8.5E-03	8.9E-03	9.7E-03	9.7E-03	
DDT[4,4'-]	mg/kg	7	21	5.9E-03	2.0E-02	4.8E-02	3.1E-02	

TABLE C-8.—Soil Detection Statistics by Watershed and by Analyte (ER Risk Database [LANL 1998]—Organics)-Continued

WATERSHED	ANALYTE NAME	UNITS	DETECTED	ANALYZED	MINIMUM	MEAN	MAXIMUM	UCL
Los Alamos Canyon (Cont.)	Di-n-butylphthalate	mg/kg	17	259	4.2E-01	1.4E+00	3.5E+00	1.8E+00
	Dibenz(a,h)anthracene	mg/kg	2	259	1.6E+00	3.0E+00	4.3E+00	5.7E+00
	Dibenzofuran	mg/kg	3	259	5.2E-01	1.7E+00	2.5E+00	2.9E+00
	Dichlorobenzene[1,3-]	mg/kg	1	264	3.7E-01	3.7E-01	3.7E-01	
	Diethylphthalate	mg/kg	1	259	6.1E-01	6.1E-01	6.1E-01	
	Endosulfan II	mg/kg	1	21	4.2E-03	4.2E-03	4.2E-03	
	Fluoranthene	mg/kg	29	259	1.8E-01	4.3E+00	4.1E+01	7.7E+00
	Fluorene	mg/kg	5	259	6.1E-01	2.2E+00	4.7E+00	3.9E+00
	Indeno(1,2,3-cd) pyrene	mg/kg	7	259	4.2E-01	2.1E+00	5.7E+00	3.9E+00
	Methylnaphthalene[2-]	mg/kg	2	259	1.0E+00	1.1E+00	1.2E+00	1.3E+00
	Methylphenol[4-]	mg/kg	1	259	3.7E-01	3.7E-01	3.7E-01	
	Naphthalene	mg/kg	3	259	5.7E-01	1.9E+00	2.7E+00	3.2E+00
	Phenanthrene	mg/kg	19	259	8.5E-02	5.7E+00	3.9E+01	1.0E+01
	Pyrene	mg/kg	30	259	2.1E-01	4.6E+00	3.9E+01	7.8E+00
	Toluene	mg/kg	4	7	1.0E-02	1.6E-02	2.9E-02	2.5E-02
	Xylene (Total)	mg/kg	2	7	9.5E-03	1.1E-02	1.2E-02	1.3E-02
Mortandad Canyon	Acenaphthene	mg/kg	3	88	4.1E-01	1.4E+00	2.6E+00	2.7E+00
	Acetone	mg/kg	1	51	1.6E-02	1.6E-02	1.6E-02	
	Aniline	mg/kg	1	88	3.1E-01	3.1E-01	3.1E-01	
	Anthracene	mg/kg	3	88	8.4E-01	2.7E+00	5.1E+00	5.2E+00
	Aroclor-1254	mg/kg	1	30	1.5E-01	1.5E-01	1.5E-01	
	Aroclor-1260	mg/kg	4	30	2.0E-02	3.6E-02	5.3E-02	5.4E-02
	Aroclors (Mixed)	mg/kg	5	30	2.0E-02	5.9E-02	1.5E-01	1.1E-01
	Benzene	mg/kg	1	51	1.0E-03	1.0E-03	1.0E-03	
	Benzo(a)anthracene	mg/kg	10	88	1.7E-01	5.7E+00	2.3E+01	1.1E+01
	Benzo(a)pyrene	mg/kg	12	88	1.5E-01	4.8E+00	2.3E+01	9.1E+00

TABLE C-8.—Soil Detection Statistics by Watershed and by Analyte (ER Risk Database [LANL 1998]—Organics)-Continued

WATERSHED	ANALYTE NAME	UNITS	DETECTED	ANALYZED	MINIMUM	MEAN	MAXIMUM	UCL
Mortandad Canyon	Benzo(b)fluoranthene	mg/kg	13	88	2.8E-01	5.2E+00	2.6E+01	1.0E+01
	Benzo(g,h,i)perylene	mg/kg	4	88	2.1E+00	6.2E+00	1.3E+01	1.1E+01
	Benzo(k)fluoranthene	mg/kg	4	84	2.0E+00	5.2E+00	1.1E+01	9.1E+00
	Benzoic Acid	mg/kg	3	88	1.1E-01	1.4E-01	1.8E-01	1.8E-01
	Bis(2-ethylhexyl) phthalate	mg/kg	5	88	7.3E-02	1.1E+00	3.8E+00	2.4E+00
	Bromodichloromethane	mg/kg	1	51	4.0E-03	4.0E-03	4.0E-03	
	Butanone[2-]	mg/kg	1	51	8.0E-03	8.0E-03	8.0E-03	
	Carbon Disulfide	mg/kg	1	51	5.8E-03	5.8E-03	5.8E-03	
	Chrysene	mg/kg	12	88	1.8E-01	5.4E+00	2.6E+01	1.0E+01
	Dibenz(a,h)anthracene	mg/kg	3	88	6.3E-01	1.6E+00	2.7E+00	2.8E+00
	Dibenzofuran	mg/kg	1	88	9.4E-01	9.4E-01	9.4E-01	
	Dichlorobenzidine [3,3'-]	mg/kg	1	88	7.0E-01	7.0E-01	7.0E-01	
	Fluoranthene	mg/kg	13	88	1.1E-01	4.8E+00	2.7E+01	9.6E+00
	Fluorene	mg/kg	2	88	7.2E-01	1.4E+00	2.1E+00	2.8E+00
	Indeno(1,2,3-cd)pyrene	mg/kg	6	88	3.9E-01	4.7E+00	1.4E+01	8.8E+00
	Isopropyltoluene[4-]	mg/kg	1	51	4.4E-02	4.4E-02	4.4E-02	
	Methyl-2-pentanone [4-]	mg/kg	1	51	3.0E-03	3.0E-03	3.0E-03	
	Naphthalene	mg/kg	2	105	2.0E-03	3.1E-01	6.1E-01	9.1E-01
	Phenanthrene	mg/kg	10	88	8.7E-02	6.5E+00	2.6E+01	1.2E+01
	Pyrene	mg/kg	14	88	1.0E-01	8.0E+00	4.4E+01	1.5E+01
	Tetrachloroethene	mg/kg	9	51	1.0E-03	2.8E-03	5.0E-03	3.8E-03
	Toluene	mg/kg	10	51	2.0E-03	8.9E-03	1.6E-02	1.2E-02
	Trichlorobenzene [1,2,3-]	mg/kg	1	17	2.0E-03	2.0E-03	2.0E-03	
Trichlorofluoromethane	mg/kg	1	51	1.9E-02	1.9E-02	1.9E-02		

TABLE C-8.—Soil Detection Statistics by Watershed and by Analyte (ER Risk Database [LANL 1998]—Organics)-Continued

WATERSHED	ANALYTE NAME	UNITS	DETECTED	ANALYZED	MINIMUM	MEAN	MAXIMUM	UCL
Mortandad Canyon (Cont.)	Trimethylbenzene [1,2,4-]	mg/kg	4	51	3.0E-03	9.3E-03	2.6E-02	2.0E-02
	Trimethylbenzene [1,3,5-]	mg/kg	1	51	8.2E-03	8.2E-03	8.2E-03	
	Xylene[1,2-]	mg/kg	1	10	1.0E-03	1.0E-03	1.0E-03	
	Xylene[1,3-]	mg/kg	6	10	1.0E-03	2.2E-03	5.0E-03	3.7E-03
Pajarito Canyon	Acenaphthene	mg/kg	1	87	5.1E-01	5.1E-01	5.1E-01	
	Acetone	mg/kg	2	41	5.3E-02	6.5E-02	7.6E-02	8.8E-02
	Aldrin	mg/kg	1	38	2.4E-03	2.4E-03	2.4E-03	
	Amino-2,6-dinitrotoluene[4-]	mg/kg	1	88	1.0E+00	1.0E+00	1.0E+00	
	Amino-4,6-dinitrotoluene[2-]	mg/kg	2	88	4.1E-01	7.1E-01	1.0E+00	1.3E+00
	Anthracene	mg/kg	2	87	1.2E+00	1.7E+01	3.2E+01	4.7E+01
	Aroclor-1254	mg/kg	2	38	1.6E+00	2.1E+00	2.6E+00	3.1E+00
	BHC[gamma-]	mg/kg	1	38	4.1E-03	4.1E-03	4.1E-03	
	Benzo(a)anthracene	mg/kg	7	87	3.7E-01	2.4E+01	1.6E+02	6.9E+01
	Benzo(a)pyrene	mg/kg	8	87	4.4E-01	1.7E+01	1.3E+02	4.9E+01
	Benzo(b)fluoranthene	mg/kg	13	87	3.9E-01	1.6E+01	2.0E+02	4.7E+01
	Benzo(g,h,i)perylene	mg/kg	4	87	4.1E-01	1.6E+01	6.4E+01	4.8E+01
	Benzo(k)fluoranthene	mg/kg	2	87	1.5E+00	3.9E+01	7.7E+01	1.1E+02
	Benzoic Acid	mg/kg	2	85	1.4E-01	1.8E-01	2.1E-01	2.5E-01
	Bis(2-ethylhexyl) phthalate	mg/kg	6	87	3.8E-01	1.2E+00	2.9E+00	1.9E+00
	Butylbenzylphthalate	mg/kg	2	87	4.6E-02	5.6E-02	6.6E-02	7.6E-02
	Carbon Disulfide	mg/kg	3	41	7.0E-03	9.6E-03	1.2E-02	1.2E-02
	Chlordane[alpha-]	mg/kg	1	38	1.6E-02	1.6E-02	1.6E-02	
Chrysene	mg/kg	10	85	4.5E-01	2.0E+01	1.9E+02	5.8E+01	

TABLE C-8.—Soil Detection Statistics by Watershed and by Analyte (ER Risk Database [LANL 1998]—Organics)-Continued

WATERSHED	ANALYTE NAME	UNITS	DETECTED	ANALYZED	MINIMUM	MEAN	MAXIMUM	UCL
Pajarito Canyon (Cont.)	DDE[4,4'-]	mg/kg	4	38	4.5E-03	1.5E-02	3.9E-02	3.1E-02
	DDT[4,4'-]	mg/kg	11	38	3.8E-03	1.4E-02	5.1E-02	2.3E-02
	Di-n-butylphthalate	mg/kg	2	87	8.5E-01	4.6E+01	9.2E+01	1.4E+02
	Di-n-octylphthalate	mg/kg	1	87	4.0E-01	4.0E-01	4.0E-01	
	Dibenz(a,h)anthracene	mg/kg	3	87	5.8E-01	8.1E+00	2.3E+01	2.3E+01
	Dieldrin	mg/kg	1	38	4.8E-02	4.8E-02	4.8E-02	
	Diethylphthalate	mg/kg	1	87	4.6E-01	4.6E-01	4.6E-01	
	Dinitrotoluene[2,4-]	mg/kg	1	175	6.0E-01	6.0E-01	6.0E-01	
	Dinitrotoluene[2,6-]	mg/kg	1	176	6.0E-01	6.0E-01	6.0E-01	
	Endosulfan I	mg/kg	2	38	6.4E-03	1.2E-02	1.7E-02	2.2E-02
	Endosulfan II	mg/kg	1	38	2.4E-02	2.4E-02	2.4E-02	
	Endrin	mg/kg	2	38	8.2E-02	1.1E-01	1.3E-01	1.5E-01
	Fluoranthene	mg/kg	15	87	5.2E-02	2.5E+01	3.1E+02	6.6E+01
	Heptachlor	mg/kg	1	38	6.1E-03	6.1E-03	6.1E-03	
	Indeno(1,2,3-cd)pyrene	mg/kg	5	87	3.6E-01	1.7E+01	8.0E+01	4.8E+01
	Isopropylbenzene	mg/kg	1	17	5.7E-02	5.7E-02	5.7E-02	
	Isopropyltoluene[4-]	mg/kg	1	17	1.1E+00	1.1E+00	1.1E+00	
	Methoxychlor[4,4'-]	mg/kg	2	38	2.7E-02	4.0E-02	5.2E-02	6.5E-02
	Methylene Chloride	mg/kg	16	41	1.1E-02	2.2E-02	6.4E-02	2.9E-02
	Nitrobenzene	mg/kg	2	175	2.0E+00	4.5E+00	7.1E+00	9.6E+00
	Phenanthrene	mg/kg	10	87	4.9E-01	1.6E+01	1.5E+02	4.6E+01
	Pyrene	mg/kg	12	87	5.1E-01	2.4E+01	2.8E+02	7.1E+01
	Toluene	mg/kg	3	41	5.0E-03	7.0E-03	8.0E-03	9.0E-03
	Trichloro-1,2,2-trifluoroethane[1,1,2-]	mg/kg	1	17	1.7E-02	1.7E-02	1.7E-02	
Trinitrobenzene[1,3,5-]	mg/kg	1	88	1.7E-01	1.7E-01	1.7E-01		

TABLE C-8.—Soil Detection Statistics by Watershed and by Analyte (ER Risk Database [LANL 1998]—Organics)-Continued

WATERSHED	ANALYTE NAME	UNITS	DETECTED	ANALYZED	MINIMUM	MEAN	MAXIMUM	UCL
Pueblo Canyon (Part of Pueblo/ Acid Canyon)	Aroclor-1260	mg/kg	1	4	4.6E-02	4.6E-02	4.6E-02	
Rio Grande	Acetone	mg/kg	2	5	7.0E-02	7.0E-02	7.0E-02	7.0E-02
Sandia Canyon	Acenaphthene	mg/kg	1	74	5.7E-01	5.7E-01	5.7E-01	
	Acetone	mg/kg	23	64	4.2E-03	5.4E-01	1.9E+00	7.9E-01
	Anthracene	mg/kg	2	92	4.7E-01	6.3E-01	7.8E-01	9.4E-01
	Aroclor-1248	mg/kg	6	110	4.7E-02	7.9E-01	2.1E+00	1.5E+00
	Aroclor-1254	mg/kg	26	113	2.1E-02	1.2E+00	3.8E+00	1.6E+00
	Aroclor-1260	mg/kg	46	113	2.2E-02	6.6E-01	3.7E+00	9.1E-01
	Aroclors (Mixed)	mg/kg	7	28	2.1E-02	6.0E-01	1.7E+00	1.1E+00
	BHC[alpha-]	mg/kg	2	82	5.1E-02	8.4E-02	1.2E-01	1.5E-01
	Benzo(a)anthracene	mg/kg	4	92	5.3E-01	2.5E+00	4.6E+00	4.2E+00
	Benzo(a)pyrene	mg/kg	7	92	5.0E-01	6.2E+00	2.2E+01	1.2E+01
	Benzo(b)fluoranthene	mg/kg	8	92	1.0E-01	6.8E+00	3.1E+01	1.4E+01
	Benzo(g,h,i)perylene	mg/kg	3	92	4.3E-01	1.1E+00	1.8E+00	1.9E+00
	Benzo(k)fluoranthene	mg/kg	5	92	1.3E-01	1.9E+00	3.6E+00	3.1E+00
	Bis(2-ethylhexyl) phthalate	mg/kg	18	92	3.6E-01	2.9E+01	9.5E+01	4.0E+01
	Butanone[2-]	mg/kg	8	63	3.0E-02	1.0E-01	3.1E-01	1.8E-01
	Butylbenzylphthalate	mg/kg	1	92	9.2E-01	9.2E-01	9.2E-01	
	Chlordane[alpha-]	mg/kg	7	36	4.7E-03	3.0E-02	1.3E-01	6.4E-02
	Chlordane[gamma-]	mg/kg	7	36	3.8E-03	3.4E-02	1.5E-01	7.3E-02
	Chrysene	mg/kg	7	92	1.6E-01	3.4E+00	9.6E+00	5.9E+00
	DDE[4,4' -]	mg/kg	7	82	8.4E-02	2.9E-01	6.1E-01	4.7E-01
DDT[4,4' -]	mg/kg	5	82	5.9E-03	1.6E-01	2.5E-01	2.6E-01	
Di-n-butylphthalate	mg/kg	1	92	4.6E+01	4.6E+01	4.6E+01		

TABLE C-8.—Soil Detection Statistics by Watershed and by Analyte (ER Risk Database [LANL 1998]—Organics)-Continued

WATERSHED	ANALYTE NAME	UNITS	DETECTED	ANALYZED	MINIMUM	MEAN	MAXIMUM	UCL
Sandia Canyon (Cont.)	Dibenz(a,h)anthracene	mg/kg	1	92	4.5E-01	4.5E-01	4.5E-01	
	Dieldrin	mg/kg	1	82	1.6E-02	1.6E-02	1.6E-02	
	Diethylphthalate	mg/kg	1	92	6.9E-01	6.9E-01	6.9E-01	
	Endosulfan I	mg/kg	4	82	8.3E-02	1.5E-01	2.3E-01	2.1E-01
	Endosulfan II	mg/kg	3	82	5.0E-03	8.2E-03	9.9E-03	1.1E-02
	Endrin	mg/kg	3	82	6.0E-01	6.0E-01	6.1E-01	6.1E-01
	Endrin Aldehyde	mg/kg	2	82	5.8E-03	5.9E-03	6.0E-03	6.1E-03
	Fluoranthene	mg/kg	9	92	3.2E-01	1.3E+01	6.0E+01	2.6E+01
	Fluorene	mg/kg	1	92	3.8E-01	3.8E-01	3.8E-01	
	Hexanone[2-]	mg/kg	2	64	2.0E-01	3.6E-01	5.1E-01	6.7E-01
	Indeno(1,2,3-cd)pyrene	mg/kg	4	92	6.6E-01	3.9E+00	1.2E+01	9.1E+00
	Isopropyltoluene[4-]	mg/kg	1	29	2.8E-01	2.8E-01	2.8E-01	
	Methyl-2-pentanone [4-]	mg/kg	3	63	6.7E-03	4.2E-02	7.9E-02	8.4E-02
	Methylene Chloride	mg/kg	6	63	2.7E-03	8.7E-03	2.5E-02	1.6E-02
	Phenanthrene	mg/kg	7	92	5.9E-01	1.3E+01	5.0E+01	2.7E+01
	Phenol	mg/kg	1	92	1.9E+00	1.9E+00	1.9E+00	
	Pyrene	mg/kg	9	92	2.2E-01	9.8E+00	4.3E+01	1.9E+01
	Tetrachloroethene	mg/kg	1	63	2.6E-03	2.6E-03	2.6E-03	
	Toluene	mg/kg	3	63	8.0E-03	1.2E-02	1.5E-02	1.6E-02
	Trichloroethane[1,1,1-]	mg/kg	1	64	1.6E-01	1.6E-01	1.6E-01	
Xylene (Total)	mg/kg	1	63	3.5E-02	3.5E-02	3.5E-02		

TABLE C-8.—Soil Detection Statistics by Watershed and by Analyte (ER Risk Database [LANL 1998]—Organics)-Continued

WATERSHED	ANALYTE NAME	UNITS	DETECTED	ANALYZED	MINIMUM	MEAN	MAXIMUM	UCL
Starmer's Gulch (Part of Pajarito Canyon)	Amino-2,6-dinitrotoluene[4-]	mg/kg	1	33	4.0E-01	4.0E-01	4.0E-01	
	Amino-4,6-dinitrotoluene[2-]	mg/kg	1	33	4.0E-01	4.0E-01	4.0E-01	
	Bis(2-ethylhexyl) phthalate	mg/kg	2	32	1.1E+00	1.9E+00	2.7E+00	3.5E+00
	HMX	mg/kg	1	53	1.7E+00	1.7E+00	1.7E+00	
	Trinitrotoluene[2,4,6-]	mg/kg	1	53	1.7E-01	1.7E-01	1.7E-01	
Ten-Site Canyon (Part of Mortandad Canyon)	Acenaphthene	mg/kg	26	315	3.5E-02	1.8E+00	9.2E+00	2.8E+00
	Acenaphthylene	mg/kg	1	315	4.1E-02	4.1E-02	4.1E-02	
	Acetone	mg/kg	23	92	7.0E-03	3.1E-02	1.2E-01	4.1E-02
	Aldrin	mg/kg	1	19	2.6E-03	2.6E-03	2.6E-03	
	Aniline	mg/kg	1	250	2.1E-01	2.1E-01	2.1E-01	
	Anthracene	mg/kg	27	315	6.9E-02	2.4E+00	1.3E+01	3.6E+00
	Aroclor-1254	mg/kg	21	337	5.0E-02	7.3E-01	6.0E+00	1.3E+00
	Aroclor-1260	mg/kg	58	341	3.0E-02	2.0E+01	3.4E+02	3.7E+01
	Aroclors (Mixed)	mg/kg	48	281	0.0E+00	4.2E-01	6.0E+00	6.9E-01
	Azobenzene	mg/kg	1	249	1.1E+01	1.1E+01	1.1E+01	
	Benzo(a)anthracene	mg/kg	43	315	2.6E-02	4.2E+00	3.7E+01	6.5E+00
	Benzo(a)pyrene	mg/kg	46	315	4.0E-02	5.1E+00	4.8E+01	8.1E+00
	Benzo(b)fluoranthene	mg/kg	44	315	3.6E-02	5.8E+00	5.2E+01	9.3E+00
	"Benzo(g,h,i)perylene"	mg/kg	36	315	5.7E-02	3.3E+00	3.3E+01	5.5E+00
	Benzo(k)fluoranthene	mg/kg	31	313	2.7E-02	4.3E+00	4.5E+01	7.6E+00
	Benzoic Acid	mg/kg	4	311	4.0E-02	2.0E-01	6.1E-01	4.8E-01
	Bis(2-ethylhexyl) phthalate	mg/kg	55	311	4.6E-02	1.7E+00	1.4E+01	2.4E+00
	Butanone[2-]	mg/kg	1	92	3.0E-03	3.0E-03	3.0E-03	
	Butylbenzylphthalate	mg/kg	3	311	9.1E-02	1.5E-01	2.7E-01	2.7E-01

TABLE C-8.—Soil Detection Statistics by Watershed and by Analyte (ER Risk Database [LANL 1998]—Organics)-Continued

WATERSHED	ANALYTE NAME	UNITS	DETECTED	ANALYZED	MINIMUM	MEAN	MAXIMUM	UCL
Ten-Site Canyon (Part of Mortandad Canyon) (Cont.)	Carbon Disulfide	mg/kg	1	92	4.0E-03	4.0E-03	4.0E-03	
	Chloroaniline[4-]	mg/kg	1	311	1.4E-01	1.4E-01	1.4E-01	
	Chrysene	mg/kg	50	315	3.8E-02	4.7E+00	4.7E+01	7.4E+00
	Di-n-butylphthalate	mg/kg	35	311	3.5E-02	9.5E-01	5.2E+00	1.3E+00
	Di-n-octylphthalate	mg/kg	2	311	3.7E-02	5.2E-01	1.0E+00	1.5E+00
	Dibenz(a,h)anthracene	mg/kg	14	315	5.5E-02	1.3E+00	8.8E+00	2.5E+00
	Dibenzofuran	mg/kg	20	311	4.7E-02	8.1E-01	3.8E+00	1.3E+00
	Dichloroethene [cis-1,2-]	mg/kg	3	79	1.0E-03	2.3E-03	3.0E-03	3.7E-03
	Dieldrin	mg/kg	1	19	5.7E-03	5.7E-03	5.7E-03	
	Dimethyl Phthalate	mg/kg	1	311	6.0E-02	6.0E-02	6.0E-02	
	Endosulfan II	mg/kg	1	19	1.6E-02	1.6E-02	1.6E-02	
	Fluoranthene	mg/kg	63	315	3.5E-02	7.6E+00	7.0E+01	1.2E+01
	Fluorene	mg/kg	20	315	1.1E-01	1.4E+00	6.4E+00	2.1E+00
	Hexachlorobenzene	mg/kg	2	311	7.1E-02	1.8E-01	2.8E-01	3.8E-01
	Hexanone[2-]	mg/kg	2	92	6.0E-03	1.0E-02	1.4E-02	1.8E-02
	Hydrocarbons, Total Petroleum	mg/kg	8	10	4.5E+01	4.7E+03	8.6E+03	7.1E+03
	Indeno(1,2,3-cd)pyrene	mg/kg	34	315	5.1E-02	3.5E+00	2.8E+01	5.6E+00
	Methylene Chloride	mg/kg	4	90	7.3E-03	2.7E-02	6.0E-02	5.1E-02
	Methylnaphthalene[2-]	mg/kg	15	311	3.5E-02	4.3E-01	1.7E+00	6.9E-01
	Methylphenol[4-]	mg/kg	1	311	3.8E-02	3.8E-02	3.8E-02	
	Naphthalene	mg/kg	21	319	0.0E+00	1.1E+00	7.0E+00	1.8E+00
	Organics, Diesel Range	mg/kg	17	40	4.9E+00	1.5E+03	2.5E+04	4.5E+03
	Pentachlorophenol	mg/kg	2	311	2.3E-01	1.1E+00	1.9E+00	2.7E+00
	Phenanthrene	mg/kg	46	315	8.0E-02	8.4E+00	5.9E+01	1.3E+01
	Phenol	mg/kg	3	311	5.8E-02	1.0E-01	1.6E-01	1.6E-01
	Pyrene	mg/kg	64	315	3.4E-02	7.9E+00	1.1E+02	1.2E+01

TABLE C-8.—Soil Detection Statistics by Watershed and by Analyte (ER Risk Database [LANL 1998]—Organics)-Continued

WATERSHED	ANALYTE NAME	UNITS	DETECTED	ANALYZED	MINIMUM	MEAN	MAXIMUM	UCL
Ten-Site Canyon (Part of Mortandad Canyon) (Cont.)	Tetrachloroethene	mg/kg	2	92	2.0E-03	2.0E-03	2.0E-03	2.0E-03
	Toluene	mg/kg	7	92	2.0E-03	8.1E-03	2.2E-02	1.4E-02
	Trichlorobenzene [1,2,4-]	mg/kg	1	313	1.4E-01	1.4E-01	1.4E-01	
	Trichloroethene	mg/kg	6	92	9.0E-03	1.4E-02	2.1E-02	1.8E-02
	Trichlorofluoromethane	mg/kg	3	91	3.0E-03	8.7E-03	1.7E-02	1.7E-02
	Xylene (Total)	mg/kg	1	90	3.0E-03	3.0E-03	3.0E-03	
Three-Mile Canyon (Part of Pajarito Canyon)	Acenaphthene	mg/kg	4	37	8.3E-01	1.1E+01	3.2E+01	2.5E+01
	Anthracene	mg/kg	6	37	1.1E+00	1.6E+01	6.3E+01	3.5E+01
	Benzo(a)anthracene	mg/kg	8	37	6.4E-01	4.2E+01	2.4E+02	9.9E+01
	Benzo(a)pyrene	mg/kg	8	37	7.8E-01	4.2E+01	2.5E+02	1.0E+02
	Benzo(b)fluoranthene	mg/kg	8	37	6.3E-01	4.7E+01	2.9E+02	1.2E+02
	Benzo(g,h,i)perylene	mg/kg	8	37	4.5E-01	2.2E+01	1.3E+02	5.3E+01
	Benzo(k)fluoranthene	mg/kg	8	37	8.6E-01	2.4E+01	1.1E+02	5.1E+01
	Benzoic Acid	mg/kg	5	37	1.3E-01	2.1E-01	3.5E-01	3.0E-01
	Bis(2-ethylhexyl) phthalate	mg/kg	3	37	6.3E-01	1.7E+00	3.3E+00	3.3E+00
	Butylbenzylphthalate	mg/kg	1	37	8.7E-01	8.7E-01	8.7E-01	
	Chrysene	mg/kg	8	37	8.0E-01	4.5E+01	2.6E+02	1.1E+02
	Di-n-butylphthalate	mg/kg	4	37	1.5E+00	8.1E+00	2.6E+01	2.0E+01
	Dibenz(a,h)anthracene	mg/kg	4	37	1.4E+00	4.2E+00	9.3E+00	7.9E+00
	Dibenzofuran	mg/kg	2	37	6.3E-01	1.5E+00	2.3E+00	3.1E+00
	Fluoranthene	mg/kg	10	37	8.0E-01	7.1E+01	5.2E+02	1.7E+02
	Fluorene	mg/kg	4	37	9.7E-01	1.1E+01	3.2E+01	2.5E+01
	HMX	mg/kg	15	102	1.3E-01	1.6E+02	2.2E+03	4.5E+02
	Indeno(1,2,3-cd)pyrene	mg/kg	8	37	5.2E-01	2.5E+01	1.4E+02	5.8E+01
	Naphthalene	mg/kg	1	37	2.6E+01	2.6E+01	2.6E+01	
	Phenanthrene	mg/kg	10	37	7.7E-01	4.2E+01	2.9E+02	9.9E+01

TABLE C-8.—Soil Detection Statistics by Watershed and by Analyte (ER Risk Database [LANL 1998]—Organics)-Continued

WATERSHED	ANALYTE NAME	UNITS	DETECTED	ANALYZED	MINIMUM	MEAN	MAXIMUM	UCL
Three-Mile Canyon (Part of Pajarito Canyon)	Pyrene	mg/kg	8	37	1.2E+00	7.6E+01	4.4E+02	1.8E+02
	RDX	mg/kg	6	102	6.3E-01	3.2E+02	1.9E+03	9.5E+02
	Trinitrobenzene[1,3,5-]	mg/kg	1	102	3.7E-01	3.7E-01	3.7E-01	
Two-Mile Canyon (Part of Pajarito Canyon)	Acetone	mg/kg	14	61	5.0E-03	2.9E-02	7.4E-02	4.1E-02
	Amino-2,6-dinitrotoluene[4-]	mg/kg	2	300	9.1E-02	1.3E-01	1.6E-01	2.0E-01
	Aroclor-1254	mg/kg	2	13	4.7E-01	4.8E-01	4.8E-01	4.9E-01
	Aroclors (Mixed)	mg/kg	2	13	4.7E-01	4.8E-01	4.8E-01	4.9E-01
	Benzo(a)anthracene	mg/kg	3	154	5.5E-02	3.0E+00	8.0E+00	8.0E+00
	Benzo(a)pyrene	mg/kg	1	154	5.3E-02	5.3E-02	5.3E-02	
	Benzo(b)fluoranthene	mg/kg	2	154	4.5E-02	4.7E-01	9.0E-01	1.3E+00
	Benzo(g,h,i)perylene	mg/kg	1	154	1.8E-01	1.8E-01	1.8E-01	
	Benzo(k)fluoranthene	mg/kg	2	154	5.8E-02	6.9E-02	8.0E-02	9.1E-02
	Benzoic Acid	mg/kg	2	138	1.2E-01	1.5E-01	1.9E-01	2.2E-01
	Bis(2-ethylhexyl) phthalate	mg/kg	17	154	3.8E-02	4.7E+00	5.1E+01	1.1E+01
	Butanone[2-]	mg/kg	1	62	9.0E-03	9.0E-03	9.0E-03	
	Chloronaphthalene[2-]	mg/kg	1	154	2.7E-01	2.7E-01	2.7E-01	
	Chrysene	mg/kg	1	152	7.3E+00	7.3E+00	7.3E+00	
	Di-n-butylphthalate	mg/kg	25	154	4.6E-02	9.3E+00	1.5E+02	2.2E+01
	Di-n-octylphthalate	mg/kg	3	154	1.0E-01	7.4E-01	2.0E+00	2.0E+00
	Dichlorobenzene[1,2-]	mg/kg	1	216	3.2E-01	3.2E-01	3.2E-01	
	Dichlorobenzene[1,3-]	mg/kg	1	216	3.1E-01	3.1E-01	3.1E-01	
	Diethylphthalate	mg/kg	1	154	4.1E-02	4.1E-02	4.1E-02	
	Dinitrobenzene[1,3-]	mg/kg	1	300	5.4E-01	5.4E-01	5.4E-01	
Dinitrotoluene[2,4-]	mg/kg	1	454	2.6E-01	2.6E-01	2.6E-01		
Dinitrotoluene[2,6-]	mg/kg	1	454	2.6E-01	2.6E-01	2.6E-01		

TABLE C-8.—*Soil Detection Statistics by Watershed and by Analyte (ER Risk Database [LANL 1998]—Organics)-Continued*

WATERSHED	ANALYTE NAME	UNITS	DETECTED	ANALYZED	MINIMUM	MEAN	MAXIMUM	UCL
Two-Mile Canyon (Part of Pajarito Canyon) (Cont.)	Fluoranthene	mg/kg	2	154	7.6E-01	1.0E+01	2.0E+01	3.0E+01
	HMX	mg/kg	11	300	8.5E-03	4.7E+00	3.8E+01	1.1E+01
	Hexachlorobenzene	mg/kg	1	154	2.7E-01	2.7E-01	2.7E-01	
	Naphthalene	mg/kg	1	170	2.3E+00	2.3E+00	2.3E+00	
	Nitrobenzene	mg/kg	1	454	1.8E-01	1.8E-01	1.8E-01	
	Nitrotoluene[3-]	mg/kg	1	300	1.6E-01	1.6E-01	1.6E-01	
	Phenanthrene	mg/kg	2	154	1.4E-01	7.6E+00	1.5E+01	2.2E+01
	Phenol	mg/kg	1	154	7.2E-02	7.2E-02	7.2E-02	
	Pyrene	mg/kg	4	154	1.9E-01	6.1E+00	2.3E+01	1.7E+01
	RDX	mg/kg	7	300	1.8E-01	1.0E+00	1.8E+00	1.4E+00
	Tetryl	mg/kg	3	300	4.3E-01	6.0E+00	9.5E+00	1.2E+01
	Toluene	mg/kg	1	62	3.0E-03	3.0E-03	3.0E-03	
	Trichloro-1,2,2-trifluoroethane[1,1,2-]	mg/kg	3	62	6.0E-03	9.3E-03	1.5E-02	1.5E-02
	Trichlorobenzene [1,2,4-]	mg/kg	1	169	3.7E-01	3.7E-01	3.7E-01	
	Trichloroethene	mg/kg	1	62	1.0E-03	1.0E-03	1.0E-03	
Trinitrotoluene[2,4,6-]	mg/kg	3	300	1.2E-01	9.0E-01	2.3E+00	2.3E+00	
Water Canyon	Acenaphthene	mg/kg	67	473	4.2E-02	3.5E+00	5.0E+01	
	Acenaphthylene	mg/kg	12	473	4.5E-02	2.7E-01	1.9E+00	5.7E-01
	Acetone	mg/kg	7	106	8.0E-03	1.8E-01	5.2E-01	3.1E-01
	Amino-2,6-dinitrotoluene[4-]	mg/kg	64	485	9.7E-02	6.5E+00	6.4E+01	9.9E+00
	Amino-4,6-dinitrotoluene[2-]	mg/kg	74	462	8.4E-02	1.0E+01	8.3E+01	1.4E+01
	Aniline	mg/kg	1	470	1.9E+00	1.9E+00	1.9E+00	
	Anthracene	mg/kg	93	473	3.7E-02	5.0E+00	1.2E+02	8.6E+00
	Aroclor-1260	mg/kg	6	32	3.8E-02	1.7E+00	3.1E+00	2.8E+00

TABLE C-8.—Soil Detection Statistics by Watershed and by Analyte (ER Risk Database [LANL 1998]—Organics)-Continued

WATERSHED	ANALYTE NAME	UNITS	DETECTED	ANALYZED	MINIMUM	MEAN	MAXIMUM	UCL
Water Canyon (Cont.)	Aroclors (Mixed)	mg/kg	4	6	2.0E+00	2.6E+00	3.1E+00	3.2E+00
	Azobenzene	mg/kg	1	411	1.9E+00	1.9E+00	1.9E+00	
	Benzene	mg/kg	1	109	2.0E-03	2.0E-03	2.0E-03	
	Benzo(a)anthracene	mg/kg	111	473	3.6E-02	1.0E+01	4.2E+02	1.9E+01
	Benzo(a)pyrene	mg/kg	121	473	5.3E-02	8.9E+00	4.6E+02	1.7E+01
	Benzo(b)fluoranthene	mg/kg	137	474	4.3E-02	1.2E+01	5.8E+02	2.2E+01
	Benzo(g,h,i)perylene	mg/kg	97	473	3.8E-02	6.7E+00	3.5E+02	1.4E+01
	Benzo(k)fluoranthene	mg/kg	84	451	4.2E-02	6.3E+00	1.5E+02	1.1E+01
	Benzoic Acid	mg/kg	49	472	3.5E-02	5.2E-01	9.5E+00	9.1E-01
	Benzyl Alcohol	mg/kg	4	472	5.2E-02	1.0E+00	3.8E+00	2.9E+00
	Bis(2-chloroethoxy) methane	mg/kg	1	472	1.9E+00	1.9E+00	1.9E+00	
	Bis(2-chloroethyl)ether	mg/kg	1	472	1.9E+00	1.9E+00	1.9E+00	
	Bis(2-ethylhexyl) phthalate	mg/kg	119	472	3.8E-02	5.3E+00	1.5E+02	8.4E+00
	Bromophenyl- phenylether[4-]	mg/kg	1	472	1.9E+00	1.9E+00	1.9E+00	
	Butanone[2-]	mg/kg	6	106	9.0E-03	2.1E-02	3.2E-02	2.8E-02
	Butylbenzylphthalate	mg/kg	4	472	3.0E-01	3.9E+00	1.3E+01	1.0E+01
	Carbazole	mg/kg	1	51	1.8E+00	1.8E+00	1.8E+00	
	Chloro-3- methylphenol[4-]	mg/kg	2	472	3.8E+00	4.6E+00	5.3E+00	6.1E+00
	Chloroaniline[4-]	mg/kg	1	472	3.8E+00	3.8E+00	3.8E+00	
	Chloronaphthalene[2-]	mg/kg	2	471	3.6E-01	1.1E+00	1.9E+00	2.7E+00
	Chlorophenol[2-]	mg/kg	2	471	3.5E-01	1.1E+00	1.9E+00	2.7E+00
	Chlorophenyl- phenyl[4-] Ether	mg/kg	1	472	1.9E+00	1.9E+00	1.9E+00	
Chrysene	mg/kg	130	473	3.8E-02	1.2E+01	6.1E+02	2.3E+01	

TABLE C-8.—*Soil Detection Statistics by Watershed and by Analyte (ER Risk Database [LANL 1998]—Organics)-Continued*

WATERSHED	ANALYTE NAME	UNITS	DETECTED	ANALYZED	MINIMUM	MEAN	MAXIMUM	UCL
Water Canyon (Cont.)	Di-n-butylphthalate	mg/kg	33	472	3.7E-02	7.6E-01	1.4E+01	1.6E+00
	Di-n-octylphthalate	mg/kg	5	472	7.8E-02	1.4E+00	4.5E+00	3.1E+00
	Dibenz(a,h)anthracene	mg/kg	56	473	3.8E-02	2.5E+00	6.8E+01	5.0E+00
	Dibenzofuran	mg/kg	47	472	3.6E-02	2.7E+00	3.1E+01	4.5E+00
	Dichlorobenzene[1,2-]	mg/kg	1	581	1.9E+00	1.9E+00	1.9E+00	
	Dichlorobenzene[1,3-]	mg/kg	1	581	1.9E+00	1.9E+00	1.9E+00	
	Dichlorobenzene[1,4-]	mg/kg	2	581	5.0E-02	9.8E-01	1.9E+00	2.8E+00
	Dichlorobenzidine [3,3'-]	mg/kg	1	472	3.8E+00	3.8E+00	3.8E+00	
	Dichloroethene [cis-1,2-]	mg/kg	11	98	1.0E-03	7.4E-03	6.7E-02	1.9E-02
	Dichlorophenol[2,4-]	mg/kg	1	472	1.9E+00	1.9E+00	1.9E+00	
	Diethylphthalate	mg/kg	7	472	5.6E-02	3.3E-01	1.9E+00	8.6E-01
	Dimethyl Phthalate	mg/kg	1	472	1.9E+00	1.9E+00	1.9E+00	
	Dimethylphenol[2,4-]	mg/kg	2	472	1.3E-01	1.0E+00	1.9E+00	2.8E+00
	Dinitro-2-methylphenol [4,6-]	mg/kg	1	472	9.5E+00	9.5E+00	9.5E+00	
	Dinitrobenzene[1,3-]	mg/kg	7	496	7.2E-02	5.8E+00	2.9E+01	1.4E+01
	Dinitrophenol[2,4-]	mg/kg	1	472	9.5E+00	9.5E+00	9.5E+00	
	Dinitrotoluene[2,4-]	mg/kg	53	967	4.6E-02	6.4E-01	4.0E+00	8.5E-01
	Dinitrotoluene[2,6-]	mg/kg	11	968	5.3E-02	3.7E-01	1.9E+00	6.9E-01
	Fluoranthene	mg/kg	163	475	3.4E-02	1.7E+01	9.8E+02	3.2E+01
	Fluorene	mg/kg	64	473	4.0E-02	3.3E+00	5.4E+01	5.6E+00
	Hexachlorobenzene	mg/kg	1	472	1.9E+00	1.9E+00	1.9E+00	
	Hexachlorobutadiene	mg/kg	1	477	1.9E+00	1.9E+00	1.9E+00	
	Hexachlorocyclo pentadiene	mg/kg	1	472	1.9E+00	1.9E+00	1.9E+00	
	Hexachloroethane	mg/kg	1	472	1.9E+00	1.9E+00	1.9E+00	

TABLE C-8.—Soil Detection Statistics by Watershed and by Analyte (ER Risk Database [LANL 1998]—Organics)-Continued

WATERSHED	ANALYTE NAME	UNITS	DETECTED	ANALYZED	MINIMUM	MEAN	MAXIMUM	UCL
Water Canyon (Cont.)	Indeno(1,2,-cd)pyrene	mg/kg	99	473	3.9E-02	6.2E+00	2.7E+02	1.2E+01
	Isophorone	mg/kg	1	472	1.9E+00	1.9E+00	1.9E+00	
	Isopropyltoluene[4-]	mg/kg	15	109	1.0E-03	9.0E-03	3.0E-02	1.3E-02
	Methyl-2-pentanone [4-]	mg/kg	1	106	2.0E-02	2.0E-02	2.0E-02	
	Methylene Chloride	mg/kg	17	109	3.0E-03	2.0E-02	1.3E-01	3.5E-02
	Methylnaphthalene[2-]	mg/kg	30	472	4.3E-02	2.1E+00	1.6E+01	3.5E+00
	Methylphenol[2-]	mg/kg	5	472	6.4E-02	7.6E-01	1.9E+00	1.6E+00
	Methylphenol[4-]	mg/kg	17	427	4.2E-02	4.3E-01	1.9E+00	6.9E-01
	Naphthalene	mg/kg	52	478	2.6E-03	3.5E+00	4.1E+01	5.7E+00
	Nitroaniline[2-]	mg/kg	1	472	9.5E+00	9.5E+00	9.5E+00	
	Nitroaniline[3-]	mg/kg	1	472	9.5E+00	9.5E+00	9.5E+00	
	Nitroaniline[4-]	mg/kg	2	472	6.8E-01	2.2E+00	3.8E+00	5.4E+00
	Nitrobenzene	mg/kg	5	968	9.1E-02	7.8E-01	1.9E+00	1.5E+00
	Nitrophenol[2-]	mg/kg	1	472	1.9E+00	1.9E+00	1.9E+00	
	Nitrophenol[4-]	mg/kg	1	472	9.5E+00	9.5E+00	9.5E+00	
	Nitroso-di-n- propylamine[N-]	mg/kg	1	472	1.9E+00	1.9E+00	1.9E+00	
	Nitrosodimethylamine [N-]	mg/kg	1	471	1.9E+00	1.9E+00	1.9E+00	
	Nitrosodiphenylamine [N-]	mg/kg	3	472	5.7E-02	7.7E-01	1.9E+00	1.9E+00
	Nitrotoluene[2-]	mg/kg	1	494	1.6E+00	1.6E+00	1.6E+00	
	Nitrotoluene[3-]	mg/kg	1	494	2.1E+00	2.1E+00	2.1E+00	
	Nitrotoluene[4-]	mg/kg	3	494	7.9E-01	4.0E+00	6.7E+00	7.4E+00
	Pentachlorophenol	mg/kg	1	472	9.5E+00	9.5E+00	9.5E+00	
	Phenanthrene	mg/kg	142	474	4.0E-02	1.3E+01	6.1E+02	2.4E+01
Phenol	mg/kg	3	472	4.3E-02	7.0E-01	1.9E+00	1.9E+00	

TABLE C-8.—*Soil Detection Statistics by Watershed and by Analyte (ER Risk Database [LANL 1998]—Organics)-Continued*

WATERSHED	ANALYTE NAME	UNITS	DETECTED	ANALYZED	MINIMUM	MEAN	MAXIMUM	UCL
Water Canyon (Cont.)	Pyrene	mg/kg	167	474	3.6E-02	1.3E+01	7.2E+02	2.4E+01
	RDX	mg/kg	85	498	1.8E-01	2.3E+03	3.0E+04	3.6E+03
	TATB	mg/kg	1	15	3.3E+00	3.3E+00	3.3E+00	
	Tetrachloroethene	mg/kg	3	109	1.0E-03	3.3E-03	7.0E-03	7.0E-03
	Tetryl	mg/kg	21	496	9.1E-02	7.1E-01	3.0E+00	1.2E+00
	Toluene	mg/kg	26	109	2.0E-03	8.2E-03	2.8E-02	1.1E-02
	Trichlorobenzene [1,2,4-]	mg/kg	1	477	1.9E+00	1.9E+00	1.9E+00	
	Trichloroethane[1,1,1-]	mg/kg	2	109	2.0E-03	3.5E-03	5.0E-03	6.5E-03
	Trichloroethene	mg/kg	23	109	2.0E-03	1.3E-02	1.1E-01	2.2E-02
	Trichlorofluoromethane	mg/kg	21	109	1.0E-03	2.5E-03	5.0E-03	3.0E-03
	Trichlorophenol[2,4,5-]	mg/kg	1	472	9.5E+00	9.5E+00	9.5E+00	
	Trichlorophenol[2,4,6-]	mg/kg	1	472	1.9E+00	1.9E+00	1.9E+00	
	Trimethylbenzene [1,2,4-]	mg/kg	3	109	5.5E-02	8.2E-02	1.2E-01	1.2E-01
	Trinitrobenzene[1,3,5-]	mg/kg	13	496	9.0E-02	6.7E-01	3.4E+00	1.2E+00
	Trinitrotoluene[2,4,6-]	mg/kg	58	496	9.3E-02	1.7E+02	4.6E+03	3.4E+02
	Xylene (Total)	mg/kg	3	109	5.5E-02	8.6E-02	1.4E-01	1.4E-01

Note: Watersheds are defined in ER Project FIMAD map G105700, July 24, 1997.

Note: The analytical data provided in these tables were obtained from the Facility for Information Management, Analysis, and Display (FIMAD) in August, 1998. The data represent analytical results for surface soil samples collected by the ER Project with a begin depth equal to 0 inches and an end depth less than or equal to 12 inches. The data were obtained from ER Project-approved fixed-site analytical laboratories using standard analytical methods (EPA methods for organics and inorganics; LANL-approved methods for radionuclides). Field measurements, non-standard measurements (e.g. x-ray fluorescence), and measurements for non-chemical specific data (e.g. gross radioactivity) were excluded. Quality assurance/quality control data were also excluded. The ER Project may have removed contaminated soil in voluntary corrective actions subsequent to sampling; therefore, some analytical results may represent contaminants that have been removed since the samples were taken.

TABLE C-9.—Soil Detection Statistics by Watershed and by Analyte (ER Risk Database [LANL 1998]—Inorganics and Radiochemistry)

WATERSHED	ANALYTE	UNITS	DETECTED	ANALYZED	MINIMUM	MEAN	MAXIMUM	UCL
Acid Canyon (Part of Pueblo/ Acid Canyon)	Aluminum	mg/kg	38	38	9.6E+02	4.6E+03	1.3E+04	5.5E+03
	Americium-241	pCi/g	1	3	1.7E+00	1.7E+00	1.7E+00	
	Antimony	mg/kg	7	50	9.0E-01	5.9E+01	1.2E+02	1.0E+02
	Arsenic	mg/kg	37	46	4.0E-01	1.5E+00	3.1E+00	1.7E+00
	Barium	mg/kg	43	46	1.1E+01	7.0E+01	3.1E+02	9.2E+01
	Beryllium	mg/kg	7	46	4.3E-01	1.8E+00	3.3E+00	2.7E+00
	Calcium	mg/kg	37	38	4.3E+02	2.1E+03	7.4E+03	2.6E+03
	Cesium-137	pCi/g	11	26	1.8E-01	5.2E-01	1.3E+00	7.5E-01
	Chromium, Total	mg/kg	38	46	2.7E+00	6.0E+00	1.2E+01	6.9E+00
	Cobalt	mg/kg	17	38	1.6E+00	3.0E+00	5.0E+00	3.5E+00
	Copper	mg/kg	10	13	1.2E+00	7.5E+00	1.7E+01	1.0E+01
	Cyanide, Total	mg/kg	1	7	5.0E-02	5.0E-02	5.0E-02	
	Iron	mg/kg	38	38	3.6E+03	7.6E+03	1.4E+04	8.4E+03
	Lead	mg/kg	44	46	4.4E+00	2.9E+01	1.6E+02	3.7E+01
	Magnesium	mg/kg	33	38	1.7E+02	9.3E+02	3.0E+03	1.2E+03
	Manganese	mg/kg	13	13	1.5E+02	2.4E+02	3.3E+02	2.7E+02
	Mercury	mg/kg	21	43	1.8E-02	3.3E-01	1.0E+00	4.5E-01
	Molybdenum	mg/kg	3	25	2.2E+00	2.5E+00	2.8E+00	2.8E+00
	Nickel	mg/kg	5	46	4.4E+00	6.0E+00	7.6E+00	7.1E+00
	Plutonium-238	pCi/g	4	39	2.6E-02	5.5E-02	9.8E-02	8.5E-02
	Plutonium-239	pCi/g	21	39	1.3E-02	8.3E+00	2.4E+01	1.1E+01
	Potassium	mg/kg	20	38	2.2E+02	7.9E+02	1.7E+03	9.7E+02
	Potassium-40	pCi/g	1	1	1.9E+01	1.9E+01	1.9E+01	
Radium-226	pCi/g	1	1	8.6E-01	8.6E-01	8.6E-01		
Selenium	mg/kg	1	46	5.5E-01	5.5E-01	5.5E-01		

TABLE C-9.—Soil Detection Statistics by Watershed and by Analyte (ER Risk Database [LANL 1998]—Inorganics and Radiochemistry)-Continued

WATERSHED	ANALYTE	UNITS	DETECTED	ANALYZED	MINIMUM	MEAN	MAXIMUM	UCL
Acid Canyon (Part of Pueblo/ Acid Canyon) (Cont.)	Silver	mg/kg	4	46	3.3E+00	5.3E+00	9.0E+00	8.0E+00
	Sodium	mg/kg	25	38	7.2E+01	1.7E+02	4.1E+02	2.0E+02
	Strontium	mg/kg	21	25	2.4E+00	9.8E+00	2.2E+01	1.3E+01
	Strontium-90	pCi/g	2	25	9.7E-01	1.3E+00	1.7E+00	2.0E+00
	Thallium	mg/kg	4	46	5.0E-02	1.6E+01	6.4E+01	4.8E+01
	Tritium	pCi/g	46	46	2.3E-02	6.5E-02	2.3E-01	8.1E-02
	Uranium-234	pCi/g	24	25	5.3E-01	1.1E+00	2.2E+00	1.2E+00
	Uranium-238	pCi/g	22	25	5.3E-01	9.1E-01	1.7E+00	1.0E+00
	Vanadium	mg/kg	32	38	3.0E+00	1.0E+01	2.3E+01	1.2E+01
	Zinc	mg/kg	38	38	2.4E+01	4.6E+01	1.0E+02	5.2E+01
Ancho Canyon	Actinium-228	pCi/g	116	161	4.8E-01	1.5E+00	4.3E+00	1.6E+00
	Aluminum	mg/kg	356	356	6.6E+02	5.2E+03	2.1E+04	5.6E+03
	Americium-241	pCi/g	8	363	1.6E-01	2.3E+00	9.3E+00	4.5E+00
	Antimony	mg/kg	18	410	7.3E-02	1.3E+01	1.8E+02	3.3E+01
	Arsenic	mg/kg	169	410	3.7E-01	2.5E+00	1.5E+02	4.3E+00
	Barium	mg/kg	411	447	4.4E+00	8.2E+01	7.5E+02	8.8E+01
	Barium-140	pCi/g	3	184	2.1E-01	2.0E+00	5.5E+00	5.5E+00
	Beryllium	mg/kg	242	447	1.5E-01	2.2E+00	3.5E+02	5.1E+00
	Bismuth-211	pCi/g	60	145	3.7E-01	2.8E+00	7.8E+00	3.2E+00
	Bismuth-212	pCi/g	19	145	5.4E-01	2.0E+00	5.2E+00	2.6E+00
	Bismuth-214	pCi/g	112	167	3.2E-01	1.3E+00	3.5E+00	1.4E+00
	Cadmium	mg/kg	108	449	7.6E-03	1.9E+01	1.5E+03	4.8E+01
	Cadmium-109	pCi/g	17	47	1.3E+00	2.2E+00	3.8E+00	2.6E+00
	Calcium	mg/kg	326	358	2.9E+00	3.1E+03	5.8E+04	3.6E+03
	Cesium-134	pCi/g	1	126	4.0E-01	4.0E-01	4.0E-01	
	Cesium-137	pCi/g	268	468	2.5E-02	5.2E-01	1.7E+01	6.5E-01

TABLE C-9.—Soil Detection Statistics by Watershed and by Analyte (ER Risk Database [LANL 1998]—Inorganics and Radiochemistry)-Continued

WATERSHED	ANALYTE	UNITS	DETECTED	ANALYZED	MINIMUM	MEAN	MAXIMUM	UCL
Ancho Canyon (Cont.)	Chromium, Total	mg/kg	371	449	1.0E+00	7.4E+00	1.3E+02	8.7E+00
	Cobalt	mg/kg	214	395	2.7E-01	7.0E+00	4.4E+02	1.2E+01
	Cobalt-57	pCi/g	1	162	2.2E-01	2.2E-01	2.2E-01	
	Cobalt-60	pCi/g	3	379	8.1E-02	9.6E+00	2.8E+01	2.8E+01
	Copper	mg/kg	327	393	8.4E-01	3.8E+02	7.8E+04	8.6E+02
	Cyanide, Total	mg/kg	13	218	2.0E-01	1.7E+00	7.7E+00	2.8E+00
	Europium-152	pCi/g	12	223	1.3E-01	2.6E-01	4.5E-01	3.1E-01
	Iron	mg/kg	355	356	1.1E+03	6.9E+03	3.2E+04	7.3E+03
	Lead	mg/kg	431	445	1.0E+00	5.3E+01	1.0E+04	1.0E+02
	Lead-210	pCi/g	30	161	1.7E+00	1.4E+01	1.6E+02	2.5E+01
	Lead-212	pCi/g	152	188	3.7E-01	1.3E+00	3.6E+00	1.4E+00
	Lead-214	pCi/g	147	183	2.9E-01	1.1E+00	3.1E+00	1.2E+00
	Magnesium	mg/kg	301	356	9.2E+01	1.2E+03	7.2E+03	1.3E+03
	Manganese	mg/kg	356	356	5.6E+01	2.3E+02	8.3E+02	2.4E+02
	Manganese-54	pCi/g	3	126	4.5E-02	1.1E-01	2.4E-01	2.4E-01
	Mercury	mg/kg	96	433	3.5E-03	1.6E+00	4.4E+01	2.8E+00
	Mercury-203	pCi/g	2	29	6.1E-02	1.9E-01	3.3E-01	4.6E-01
	Neptunium-237	pCi/g	11	243	4.6E-01	7.9E-01	1.5E+00	1.0E+00
	Nickel	mg/kg	241	447	1.1E+00	1.1E+01	4.3E+02	1.6E+01
	Plutonium-238	pCi/g	66	156	2.0E-03	4.0E-02	1.1E+00	7.4E-02
	Plutonium-239	pCi/g	66	78	5.0E-03	5.2E-01	1.4E+01	9.6E-01
	Potassium	mg/kg	261	355	1.8E+02	1.3E+03	8.4E+03	1.4E+03
	Potassium-40	pCi/g	227	264	1.5E+01	2.8E+01	4.4E+01	2.8E+01
Protactinium-231	pCi/g	16	127	1.1E+00	2.1E+00	5.4E+00	2.6E+00	
Protactinium-234	pCi/g	9	112	9.4E-01	5.9E+00	1.3E+01	8.6E+00	
Protactinium-234M	pCi/g	29	126	6.5E+00	8.5E+02	1.0E+04	1.6E+03	

TABLE C-9.—Soil Detection Statistics by Watershed and by Analyte (ER Risk Database [LANL 1998]—Inorganics and Radiochemistry)-Continued

WATERSHED	ANALYTE	UNITS	DETECTED	ANALYZED	MINIMUM	MEAN	MAXIMUM	UCL
Ancho Canyon (Cont.)	Radium-223	pCi/g	5	126	1.7E-01	4.5E-01	1.2E+00	8.4E-01
	Radium-224	pCi/g	47	151	8.4E-01	3.1E+00	7.4E+00	3.6E+00
	Radium-226	pCi/g	132	213	7.9E-01	2.5E+01	1.7E+03	5.5E+01
	Radon-219	pCi/g	2	135	2.2E-01	2.1E+00	4.0E+00	5.9E+00
	Ruthenium-106	pCi/g	1	321	3.6E+00	3.6E+00	3.6E+00	
	Selenium	mg/kg	15	409	6.7E-02	7.8E+00	1.0E+02	2.2E+01
	Silver	mg/kg	28	449	2.5E-01	1.1E+01	1.0E+02	2.1E+01
	Sodium	mg/kg	236	355	3.4E+01	1.8E+02	5.9E+03	2.3E+02
	Sodium-22	pCi/g	2	321	1.9E-01	2.9E-01	3.8E-01	4.8E-01
	Thallium	mg/kg	12	433	1.1E-01	2.0E+01	2.3E+02	5.9E+01
	Thallium-208	pCi/g	161	179	1.4E-01	4.8E-01	1.4E+00	5.1E-01
	Thorium	mg/kg	27	54	3.7E+00	9.4E+00	1.6E+01	1.1E+01
	Thorium-227	pCi/g	7	127	9.4E-01	2.7E+00	9.6E+00	5.1E+00
	Thorium-228	pCi/g	111	111	4.2E-01	1.5E+00	3.5E+00	1.7E+00
	Thorium-230	pCi/g	93	111	3.8E-01	1.5E+00	3.2E+00	1.6E+00
	Thorium-232	pCi/g	121	151	5.5E-01	1.7E+00	4.4E+00	1.9E+00
	Thorium-234	pCi/g	62	158	1.1E+00	1.8E+02	3.6E+03	3.1E+02
	Uranium	mg/kg	233	405	4.5E-01	4.4E+02	3.5E+04	8.1E+02
	Uranium-234	pCi/g	19	20	5.0E-01	5.1E+00	5.6E+01	1.1E+01
	Uranium-235	pCi/g	42	166	1.1E-01	6.2E+00	1.1E+02	1.2E+01
	Uranium-238	pCi/g	20	20	7.4E-01	4.5E+01	6.9E+02	1.1E+02
	Vanadium	mg/kg	255	356	7.2E-01	1.1E+01	1.3E+02	1.2E+01
	Yttrium-88	pCi/g	1	28	3.0E-01	3.0E-01	3.0E-01	
Zinc	mg/kg	407	407	8.9E+00	6.5E+01	4.0E+03	8.7E+01	

TABLE C-9.—Soil Detection Statistics by Watershed and by Analyte (ER Risk Database [LANL 1998]—Inorganics and Radiochemistry)-Continued

WATERSHED	ANALYTE	UNITS	DETECTED	ANALYZED	MINIMUM	MEAN	MAXIMUM	UCL
Barrancas Canyon	Aluminum	mg/kg	38	38	6.3E+02	2.5E+03	7.1E+03	3.1E+03
	Arsenic	mg/kg	6	38	2.1E+00	2.7E+00	3.4E+00	3.1E+00
	Barium	mg/kg	7	38	4.4E+01	7.3E+01	1.0E+02	8.8E+01
	Beryllium	mg/kg	1	38	1.0E+00	1.0E+00	1.0E+00	
	Calcium	mg/kg	12	38	1.1E+03	4.1E+03	1.4E+04	6.6E+03
	Cesium-137	pCi/g	3	3	2.9E-01	3.1E-01	3.4E-01	3.4E-01
	Chromium, Total	mg/kg	9	38	2.1E+00	3.2E+00	4.9E+00	3.9E+00
	Copper	mg/kg	9	38	6.2E+00	8.9E+00	1.8E+01	1.1E+01
	Iron	mg/kg	38	38	1.3E+03	4.6E+03	1.0E+04	5.3E+03
	Lead	mg/kg	38	38	1.4E+00	9.9E+00	2.8E+01	1.2E+01
	Magnesium	mg/kg	6	38	1.1E+03	1.4E+03	1.7E+03	1.5E+03
	Manganese	mg/kg	38	38	7.2E+01	2.1E+02	3.9E+02	2.4E+02
	Mercury	mg/kg	1	38	1.2E-01	1.2E-01	1.2E-01	
	Nickel	mg/kg	1	38	1.0E+02	1.0E+02	1.0E+02	
	Potassium	mg/kg	4	38	1.2E+03	1.3E+03	1.4E+03	1.4E+03
	Strontium-90	pCi/g	3	38	5.3E-01	9.1E-01	1.1E+00	1.3E+00
Zinc	mg/kg	38	38	8.2E+00	4.7E+01	6.7E+02	8.1E+01	
Bayo Canyon	Aluminum	mg/kg	90	90	1.1E+03	8.7E+03	6.9E+04	1.2E+04
	Arsenic	mg/kg	9	90	8.0E-01	1.7E+00	3.4E+00	2.4E+00
	Barium	mg/kg	43	90	4.4E+01	1.0E+02	5.2E+02	1.3E+02
	Beryllium	mg/kg	1	90	1.1E+00	1.1E+00	1.1E+00	
	Cadmium	mg/kg	1	90	1.1E+00	1.1E+00	1.1E+00	
	Calcium	mg/kg	52	90	1.1E+03	2.8E+03	3.4E+04	4.0E+03
	Cesium-137	pCi/g	7	7	3.2E-02	2.8E-01	6.2E-01	4.4E-01
	Chromium, Total	mg/kg	53	90	2.0E+00	4.5E+00	2.1E+01	5.4E+00
	Cobalt	mg/kg	4	90	4.0E+00	8.5E+00	1.8E+01	1.5E+01

TABLE C-9.—Soil Detection Statistics by Watershed and by Analyte (ER Risk Database [LANL 1998]—Inorganics and Radiochemistry)-Continued

WATERSHED	ANALYTE	UNITS	DETECTED	ANALYZED	MINIMUM	MEAN	MAXIMUM	UCL
Bayo Canyon (Cont.)	Copper	mg/kg	24	90	5.2E+00	1.1E+01	5.1E+01	1.5E+01
	Europium-152	pCi/g	2	7	1.5E-01	2.5E-01	3.5E-01	4.5E-01
	Iron	mg/kg	90	90	1.7E+03	6.3E+03	1.9E+04	7.0E+03
	Lead	mg/kg	90	90	3.3E+00	1.5E+01	1.6E+02	1.9E+01
	Lithium	mg/kg	7	7	2.1E+01	2.6E+01	2.9E+01	2.8E+01
	Magnesium	mg/kg	29	90	4.8E+02	1.3E+03	3.4E+03	1.6E+03
	Manganese	mg/kg	90	90	9.2E+01	2.6E+02	8.7E+02	2.9E+02
	Mercury	mg/kg	1	83	5.2E-01	5.2E-01	5.2E-01	
	Molybdenum	mg/kg	1	7	4.0E+00	4.0E+00	4.0E+00	
	Nickel	mg/kg	3	90	8.0E+00	9.5E+00	1.2E+01	1.2E+01
	Potassium	mg/kg	37	90	1.1E+03	7.4E+03	3.8E+04	1.2E+04
	Sodium	mg/kg	7	90	1.6E+04	2.6E+04	3.1E+04	3.1E+04
	Strontium	mg/kg	7	7	3.0E+01	5.9E+01	1.2E+02	8.9E+01
	Strontium-90	pCi/g	6	86	1.7E+00	8.7E+00	1.3E+01	1.3E+01
	Thallium	mg/kg	1	90	1.0E+01	1.0E+01	1.0E+01	
	Vanadium	mg/kg	19	90	4.0E+00	1.5E+01	4.5E+01	2.0E+01
Zinc	mg/kg	90	90	1.1E+01	3.1E+01	8.8E+01	3.4E+01	
Cañada del Buey	Aluminum	mg/kg	157	157	6.7E+02	4.7E+03	1.7E+04	5.1E+03
	Americium-241	pCi/g	23	88	5.0E-03	1.3E-01	1.0E+00	2.3E-01
	Antimony	mg/kg	4	194	8.0E-02	2.0E+01	7.6E+01	5.7E+01
	Arsenic	mg/kg	92	194	9.0E-01	5.1E+00	2.1E+02	9.6E+00
	Barium	mg/kg	147	194	1.1E+01	8.4E+01	4.1E+02	9.3E+01
	Beryllium	mg/kg	48	194	3.9E-01	8.4E-01	6.0E+00	1.1E+00
	Cadmium	mg/kg	30	194	6.2E-01	4.1E+00	4.7E+01	7.2E+00
	Calcium	mg/kg	132	157	3.6E+02	2.4E+03	2.3E+04	2.9E+03
	Cesium	mg/kg	13	27	3.0E-01	2.5E+00	9.1E+00	4.3E+00

TABLE C-9.—Soil Detection Statistics by Watershed and by Analyte (ER Risk Database [LANL 1998]—Inorganics and Radiochemistry)-Continued

WATERSHED	ANALYTE	UNITS	DETECTED	ANALYZED	MINIMUM	MEAN	MAXIMUM	UCL
Cañada del Buey (Cont.)	Cesium-137	pCi/g	61	170	3.6E-02	3.0E-01	1.2E+00	3.7E-01
	Chromium, Total	mg/kg	178	194	1.3E+00	1.6E+01	8.1E+02	2.6E+01
	Cobalt	mg/kg	22	157	8.0E-01	7.6E+00	6.0E+01	1.4E+01
	Copper	mg/kg	122	157	8.1E-01	2.2E+02	8.1E+03	3.9E+02
	Cyanide, Total	mg/kg	1	2	1.2E+00	1.2E+00	1.2E+00	
	Iron	mg/kg	157	157	1.7E+03	7.3E+03	3.3E+04	8.1E+03
	Lead	mg/kg	190	194	2.9E+00	2.8E+02	4.4E+04	7.4E+02
	Lithium	mg/kg	9	27	2.1E+00	6.0E+00	2.2E+01	1.0E+01
	Magnesium	mg/kg	72	157	1.9E+02	1.3E+03	4.3E+03	1.4E+03
	Manganese	mg/kg	157	157	4.5E+01	2.2E+02	7.1E+02	2.4E+02
	Mercury	mg/kg	97	171	2.0E-02	5.6E+00	1.6E+02	9.9E+00
	Nickel	mg/kg	70	194	2.3E+00	2.4E+01	4.9E+02	4.1E+01
	Plutonium-238	pCi/g	53	100	4.5E-03	6.1E-01	1.7E+01	1.3E+00
	Plutonium-239	pCi/g	52	79	3.8E-03	5.8E-01	8.7E+00	9.5E-01
	Potassium	mg/kg	58	159	2.6E+02	1.2E+03	2.2E+03	1.4E+03
	Potassium-40	pCi/g	36	38	2.0E+01	3.2E+01	4.4E+01	3.4E+01
	Radium-226	pCi/g	22	37	1.8E+00	2.7E+00	4.2E+00	3.0E+00
	Selenium	mg/kg	11	194	6.2E-01	3.6E+01	3.6E+02	1.0E+02
	Silver	mg/kg	18	194	7.9E-01	4.3E+01	1.8E+02	7.2E+01
	Sodium	mg/kg	12	157	5.2E+01	2.0E+02	6.3E+02	3.2E+02
	Thallium	mg/kg	33	194	4.0E-02	7.0E+00	2.3E+02	2.1E+01
	Thorium-228	pCi/g	92	103	3.0E-02	5.2E-01	1.8E+00	6.0E-01
	Thorium-230	pCi/g	94	103	3.4E-02	4.2E-01	1.4E+00	4.9E-01
Thorium-232	pCi/g	99	140	2.6E-02	7.1E-01	4.3E+00	8.8E-01	
Tritium	pCi/g	31	31	1.3E-02	6.2E-02	2.0E-01	7.6E-02	
Uranium-234	pCi/g	189	189	1.7E-01	1.1E+01	6.0E+02	2.0E+01	

TABLE C-9.—Soil Detection Statistics by Watershed and by Analyte (ER Risk Database [LANL 1998]—Inorganics and Radiochemistry)-Continued

WATERSHED	ANALYTE	UNITS	DETECTED	ANALYZED	MINIMUM	MEAN	MAXIMUM	UCL
Cañada del Buey (Cont.)	Uranium-235	pCi/g	97	206	2.0E-02	1.2E+00	4.2E+01	2.3E+00
	Uranium-238	pCi/g	189	226	1.7E-01	1.2E+00	1.7E+01	1.5E+00
	Vanadium	mg/kg	80	157	2.5E+00	1.5E+01	7.6E+01	1.7E+01
	Zinc	mg/kg	157	157	1.1E+01	1.5E+02	3.4E+03	2.1E+02
Chaquehui Canyon	Acetone	mg/kg	1	3	4.5E-02	4.5E-02	4.5E-02	
	Aluminum	mg/kg	138	138	1.4E+03	5.3E+03	1.4E+04	5.7E+03
	Antimony	mg/kg	58	348	2.2E-02	3.2E+00	7.0E+01	6.6E+00
	Arsenic	mg/kg	233	345	6.2E-01	2.8E+00	1.8E+01	3.2E+00
	Barium	mg/kg	332	345	2.0E+01	1.0E+02	1.3E+03	1.1E+02
	Beryllium	mg/kg	219	345	1.6E-01	7.0E-01	7.8E+00	7.8E-01
	Cadmium	mg/kg	73	345	4.0E-01	1.1E+01	6.2E+02	2.8E+01
	Calcium	mg/kg	126	139	5.9E+02	3.8E+03	3.8E+04	4.7E+03
	Cesium-137	pCi/g	123	323	4.0E-02	9.4E-01	1.7E+01	1.2E+00
	Chromium, Total	mg/kg	325	344	1.4E+00	1.1E+01	6.7E+02	1.5E+01
	Cobalt	mg/kg	33	139	1.6E+00	4.3E+00	1.9E+01	5.7E+00
	Copper	mg/kg	123	139	3.1E+00	9.0E+02	2.5E+04	1.5E+03
	Cyanide, Total	mg/kg	15	27	2.2E-01	9.3E-01	2.6E+00	1.3E+00
	Iron	mg/kg	139	139	2.3E+03	8.2E+03	6.1E+04	9.7E+03
	Lead	mg/kg	323	350	2.9E+00	4.1E+01	2.0E+03	5.6E+01
	Magnesium	mg/kg	95	139	1.6E+02	1.4E+03	3.7E+03	1.5E+03
	Manganese	mg/kg	139	139	8.0E+01	2.3E+02	8.9E+02	2.5E+02
	Mercury	mg/kg	29	151	2.0E-02	2.0E+00	2.3E+01	3.9E+00
	Nickel	mg/kg	211	345	2.3E+00	4.2E+01	3.1E+03	7.4E+01
	Plutonium-238	pCi/g	1	112	1.7E-02	1.7E-02	1.7E-02	
Plutonium-239	pCi/g	66	112	1.1E-02	5.4E-02	9.5E-01	8.4E-02	
Potassium	mg/kg	96	139	2.4E+02	1.4E+03	3.1E+03	1.6E+03	

TABLE C-9.—Soil Detection Statistics by Watershed and by Analyte (ER Risk Database [LANL 1998]—Inorganics and Radiochemistry)-Continued

WATERSHED	ANALYTE	UNITS	DETECTED	ANALYZED	MINIMUM	MEAN	MAXIMUM	UCL
Chaquehui Canyon (Cont.)	Selenium	mg/kg	27	345	5.8E-01	1.8E+00	1.1E+01	2.7E+00
	Silver	mg/kg	30	345	3.6E-01	1.0E+01	4.6E+01	1.5E+01
	Sodium	mg/kg	32	139	6.1E+01	1.3E+02	3.2E+02	1.6E+02
	Thallium	mg/kg	2	139	1.8E+00	2.0E+00	2.2E+00	2.4E+00
	Tritium	pCi/g	125	126	1.5E-02	1.9E+02	1.2E+04	4.1E+02
	Uranium	mg/kg	31	323	2.5E-01	8.3E+00	1.3E+02	1.7E+01
	Uranium-234	pCi/g	1	1	2.7E+00	2.7E+00	2.7E+00	
	Uranium-235	pCi/g	1	1	1.8E-01	1.8E-01	1.8E-01	
	Uranium-238	pCi/g	1	1	6.2E+00	6.2E+00	6.2E+00	
	Vanadium	mg/kg	57	139	4.2E+00	1.2E+01	2.8E+01	1.3E+01
Zinc	mg/kg	345	345	1.2E+01	1.1E+02	9.4E+03	1.7E+02	
DP Canyon (Part of Los Alamos Canyon)	Actinium-227	pCi/g	4	112	1.8E+01	5.5E+01	1.1E+02	9.5E+01
	Actinium-228	pCi/g	80	82	6.6E-01	3.6E+00	1.1E+02	6.7E+00
	Aluminum	mg/kg	713	936	6.3E+00	6.8E+03	3.4E+04	7.1E+03
	Americium-241	pCi/g	476	805	5.0E-03	1.1E+01	2.6E+03	2.2E+01
	Antimony	mg/kg	26	936	2.2E-01	1.4E+01	6.4E+01	2.0E+01
	Arsenic	mg/kg	649	935	4.8E-01	2.7E+00	3.5E+01	2.9E+00
	Barium	mg/kg	909	935	9.0E-01	1.5E+02	1.7E+03	1.6E+02
	Beryllium	mg/kg	462	936	1.1E-01	1.8E+00	1.2E+02	2.4E+00
	Bismuth-211	pCi/g	73	85	7.8E-02	3.7E+00	4.3E+01	4.9E+00
	Bismuth-212	pCi/g	22	76	8.7E-01	6.6E+00	7.4E+01	1.4E+01
	Bismuth-214	pCi/g	71	74	5.0E-01	1.1E+00	5.0E+00	1.3E+00
	Cadmium	mg/kg	205	936	6.0E-02	2.8E+00	1.1E+02	4.1E+00
	Cadmium-109	pCi/g	2	2	1.1E+00	6.6E+00	1.2E+01	1.8E+01
	Calcium	mg/kg	683	935	6.0E-02	3.1E+03	4.4E+04	3.3E+03
Cerium-144	pCi/g	1	92	1.9E-01	1.9E-01	1.9E-01		

TABLE C-9.—Soil Detection Statistics by Watershed and by Analyte (ER Risk Database [LANL 1998]—Inorganics and Radiochemistry)-Continued

WATERSHED	ANALYTE	UNITS	DETECTED	ANALYZED	MINIMUM	MEAN	MAXIMUM	UCL
DP Canyon (Part of Los Alamos Canyon) (Cont.)	Cesium-134	pCi/g	5	77	5.7E-02	1.4E+00	4.9E+00	3.3E+00
	Cesium-137	pCi/g	229	369	5.0E-02	3.7E+01	2.7E+03	6.6E+01
	Chromium, Total	mg/kg	857	936	1.7E+00	1.7E+01	1.0E+03	2.1E+01
	Cobalt	mg/kg	469	936	8.1E-01	7.1E+00	4.3E+02	9.8E+00
	Cobalt-57	pCi/g	4	85	5.2E-01	3.2E+00	8.1E+00	6.5E+00
	Cobalt-60	pCi/g	2	92	3.2E-02	4.5E-02	5.8E-02	7.1E-02
	Copper	mg/kg	731	936	1.4E+00	2.1E+01	1.9E+03	2.8E+01
	Cyanide, Total	mg/kg	3	5	7.6E-01	1.2E+00	2.0E+00	2.0E+00
	Europium-152	pCi/g	2	23	2.6E-01	4.9E-01	7.1E-01	9.4E-01
	Iron	mg/kg	705	936	5.9E+00	8.4E+03	1.1E+05	8.9E+03
	Lead	mg/kg	816	936	3.7E+00	4.1E+01	6.9E+03	5.9E+01
	Lead-210	pCi/g	46	162	1.7E+00	3.1E+00	1.1E+01	3.6E+00
	Lead-211	pCi/g	1	71	2.2E+01	2.2E+01	2.2E+01	
	Lead-212	pCi/g	205	207	3.4E-01	2.4E+00	1.2E+02	3.8E+00
	Lead-214	pCi/g	196	199	4.5E-01	1.2E+00	3.5E+00	1.2E+00
	Lithium	mg/kg	443	579	2.0E+00	1.6E+01	6.1E+01	1.7E+01
	Magnesium	mg/kg	619	936	1.1E+00	1.4E+03	4.7E+03	1.5E+03
	Manganese	mg/kg	933	935	1.2E+00	2.9E+02	9.2E+02	3.0E+02
	Manganese-54	pCi/g	4	72	3.7E-02	1.5E+00	4.9E+00	3.8E+00
	Mercury	mg/kg	91	355	4.0E-02	1.0E+00	1.8E+01	1.6E+00
	Molybdenum	mg/kg	29	601	1.6E+00	5.2E+00	2.1E+01	7.2E+00
	Nickel	mg/kg	338	935	1.9E+00	1.1E+01	2.7E+02	1.4E+01
	Plutonium-238	pCi/g	529	977	4.0E-04	1.2E+00	1.3E+02	1.8E+00
	Plutonium-239	pCi/g	910	946	3.9E-03	6.8E+00	7.7E+02	9.2E+00
	Potassium	mg/kg	556	937	1.4E+00	1.3E+03	4.2E+03	1.4E+03
	Potassium-40	pCi/g	214	221	1.4E+01	2.7E+01	7.2E+01	2.8E+01

TABLE C-9.—Soil Detection Statistics by Watershed and by Analyte (ER Risk Database [LANL 1998]—Inorganics and Radiochemistry)-Continued

WATERSHED	ANALYTE	UNITS	DETECTED	ANALYZED	MINIMUM	MEAN	MAXIMUM	UCL
DP Canyon (Part of Los Alamos Canyon) (Cont.)	Protactinium-231	pCi/g	18	72	2.1E+00	3.8E+00	1.2E+01	4.9E+00
	Protactinium-234M	pCi/g	6	72	9.3E+00	6.4E+01	2.9E+02	1.5E+02
	Radium-223	pCi/g	8	77	4.0E-01	9.8E+00	3.4E+01	1.9E+01
	Radium-224	pCi/g	90	107	5.0E-01	3.6E+00	5.8E+00	3.9E+00
	Radium-226	pCi/g	116	130	6.9E-01	2.5E+00	1.9E+01	2.9E+00
	Radium-228	pCi/g	1	1	1.4E+00	1.4E+00	1.4E+00	
	Radon-219	pCi/g	4	73	7.8E-01	1.1E+01	2.7E+01	2.4E+01
	Ruthenium-106	pCi/g	1	93	9.3E+00	9.3E+00	9.3E+00	
	Selenium	mg/kg	33	935	2.0E-01	2.5E+00	5.9E+01	6.0E+00
	Silver	mg/kg	33	933	2.0E-01	1.1E+01	1.1E+02	1.9E+01
	Sodium	mg/kg	263	855	4.0E+01	3.9E+02	2.1E+04	5.6E+02
	Sodium-22	pCi/g	2	94	2.3E-01	2.5E-01	2.7E-01	2.9E-01
	Strontium	mg/kg	577	587	2.5E+00	4.5E+01	2.7E+02	4.8E+01
	Strontium-85	pCi/g	1	2	1.8E-01	1.8E-01	1.8E-01	
	Strontium-90	pCi/g	169	969	3.7E-02	3.1E+01	1.8E+03	5.9E+01
	Thallium	mg/kg	44	938	1.1E-01	3.0E+00	5.9E+01	6.0E+00
	Thallium-208	pCi/g	119	121	1.4E-01	9.5E-01	3.8E+01	1.6E+00
	Thorium-227	pCi/g	13	75	4.3E+00	3.5E+01	2.4E+02	7.4E+01
	Thorium-228	pCi/g	114	130	7.0E-01	2.6E+00	9.1E+01	4.3E+00
	Thorium-229	pCi/g	1	3	2.9E-01	2.9E-01	2.9E-01	
	Thorium-230	pCi/g	109	114	6.0E-01	2.0E+00	5.7E+01	3.1E+00
	Thorium-232	pCi/g	111	114	6.4E-01	2.7E+00	1.1E+02	4.8E+00
	Thorium-234	pCi/g	98	166	1.1E+00	2.6E+00	1.6E+01	3.0E+00
	Tritium	pCi/g	386	406	1.7E-03	7.9E+00	8.9E+02	1.4E+01
	Uranium-234	pCi/g	178	178	5.8E-01	5.7E+02	7.2E+04	1.4E+03
Uranium-235	pCi/g	78	306	3.0E-02	1.7E+02	4.6E+03	3.3E+02	

TABLE C-9.—Soil Detection Statistics by Watershed and by Analyte (ER Risk Database [LANL 1998]—Inorganics and Radiochemistry)-Continued

WATERSHED	ANALYTE	UNITS	DETECTED	ANALYZED	MINIMUM	MEAN	MAXIMUM	UCL
DP Canyon (Part of Los Alamos Canyon) (Cont.)	Uranium-238	pCi/g	179	180	6.3E-01	5.7E+00	3.7E+02	1.1E+01
	Vanadium	mg/kg	826	936	2.6E+00	1.8E+01	1.3E+02	1.9E+01
	Zinc	mg/kg	934	936	2.4E+00	7.2E+01	3.0E+03	8.2E+01
Frijoles Canyon	Actinium-228	pCi/g	6	6	9.8E-01	1.4E+00	1.9E+00	1.7E+00
	Bismuth-214	pCi/g	6	6	6.0E-01	8.8E-01	1.0E+00	1.0E+00
	Cesium-137	pCi/g	5	6	3.3E-01	5.0E-01	1.0E+00	7.7E-01
	Lead	mg/kg	3	3	6.1E+00	1.3E+01	1.8E+01	2.0E+01
	Lead-212	pCi/g	6	6	1.1E+00	1.4E+00	1.7E+00	1.6E+00
	Lead-214	pCi/g	6	6	7.2E-01	1.0E+00	1.2E+00	1.2E+00
	Neptunium-237	pCi/g	1	6	9.4E-01	9.4E-01	9.4E-01	
	Potassium-40	pCi/g	6	6	2.5E+01	3.0E+01	3.5E+01	3.3E+01
	Radium-226	pCi/g	6	6	6.0E-01	8.8E-01	1.0E+00	1.0E+00
	Thallium-208	pCi/g	6	6	2.9E-01	4.1E-01	4.9E-01	4.7E-01
Graduation Canyon (Part of Pueblo/Acid Canyon)	Aluminum	mg/kg	8	8	3.6E+03	4.8E+03	6.6E+03	5.6E+03
	Americium-241	pCi/g	8	8	1.5E-02	2.2E-02	2.5E-02	2.4E-02
	Antimony	mg/kg	6	8	2.7E-01	4.6E-01	6.5E-01	6.0E-01
	Arsenic	mg/kg	7	8	1.1E+00	2.1E+00	3.2E+00	2.7E+00
	Barium	mg/kg	8	8	4.6E+01	8.5E+01	1.2E+02	1.0E+02
	Beryllium	mg/kg	8	8	3.9E-01	4.9E-01	5.5E-01	5.3E-01
	Cadmium	mg/kg	4	8	7.2E-01	8.5E-01	9.5E-01	9.5E-01
	Calcium	mg/kg	8	8	3.0E+03	4.8E+03	6.9E+03	6.0E+03
	Cesium-137	pCi/g	5	8	7.3E-01	1.5E+00	1.8E+00	1.9E+00
	Chromium, Total	mg/kg	8	8	3.0E+00	5.0E+00	7.2E+00	6.1E+00
	Cobalt	mg/kg	2	8	2.4E+00	3.0E+00	3.5E+00	4.1E+00
	Copper	mg/kg	8	8	4.4E+00	7.6E+00	1.6E+01	1.0E+01

TABLE C-9.—Soil Detection Statistics by Watershed and by Analyte (ER Risk Database [LANL 1998]—Inorganics and Radiochemistry)-Continued

WATERSHED	ANALYTE	UNITS	DETECTED	ANALYZED	MINIMUM	MEAN	MAXIMUM	UCL
Graduation Canyon (Part of Pueblo/Acid Canyon) (Cont.)	Iron	mg/kg	8	8	4.5E+03	6.2E+03	8.1E+03	7.0E+03
	Lead	mg/kg	8	8	2.0E+01	3.2E+01	4.7E+01	3.9E+01
	Lithium	mg/kg	8	8	2.8E+00	4.4E+00	5.6E+00	5.0E+00
	Magnesium	mg/kg	8	8	8.2E+02	1.2E+03	1.7E+03	1.4E+03
	Manganese	mg/kg	8	8	2.2E+02	3.1E+02	4.0E+02	3.5E+02
	Nickel	mg/kg	4	8	3.5E+00	4.6E+00	5.8E+00	5.5E+00
	Plutonium-239	pCi/g	8	8	1.7E-01	3.8E-01	6.2E-01	4.8E-01
	Potassium	mg/kg	8	8	4.9E+02	1.0E+03	1.6E+03	1.3E+03
	Selenium	mg/kg	1	8	6.4E-01	6.4E-01	6.4E-01	
	Strontium	mg/kg	8	8	1.7E+01	2.5E+01	4.0E+01	3.1E+01
	Tritium	pCi/g	7	8	1.1E-01	3.1E-01	7.9E-01	4.8E-01
	Uranium-234	pCi/g	8	8	1.9E+00	2.2E+00	2.8E+00	2.4E+00
	Uranium-238	pCi/g	8	8	1.8E+00	2.3E+00	3.0E+00	2.5E+00
	Vanadium	mg/kg	8	8	5.2E+00	9.2E+00	1.3E+01	1.1E+01
Zinc	mg/kg	8	8	3.7E+01	4.9E+01	6.6E+01	5.6E+01	
Los Alamos Canyon	Actinium-228	pCi/g	24	34	9.2E-01	1.6E+00	2.0E+00	1.7E+00
	Aluminum	mg/kg	133	145	3.7E+02	4.1E+03	2.7E+04	4.7E+03
	Americium-241	pCi/g	49	121	7.0E-03	3.2E-01	3.3E+00	5.2E-01
	Antimony	mg/kg	55	421	4.0E-02	2.1E+01	1.1E+02	3.0E+01
	Arsenic	mg/kg	277	416	2.6E-01	1.9E+00	1.8E+01	2.1E+00
	Barium	mg/kg	368	382	5.8E+00	8.0E+01	9.2E+02	8.9E+01
	Beryllium	mg/kg	163	383	4.0E-02	1.2E+00	1.0E+01	1.4E+00
	Bismuth-211	pCi/g	12	33	6.5E-01	9.4E-01	1.8E+00	1.1E+00
	Bismuth-214	pCi/g	18	34	8.4E-01	1.3E+00	2.1E+00	1.5E+00
	Boron	mg/kg	1	21	1.4E+00	1.4E+00	1.4E+00	
	Cadmium	mg/kg	51	383	5.0E-02	7.7E-01	5.6E+00	1.0E+00

TABLE C-9.—Soil Detection Statistics by Watershed and by Analyte (ER Risk Database [LANL 1998]—Inorganics and Radiochemistry)-Continued

WATERSHED	ANALYTE	UNITS	DETECTED	ANALYZED	MINIMUM	MEAN	MAXIMUM	UCL
Los Alamos Canyon (Cont.)	Calcium	mg/kg	129	145	3.1E+02	2.5E+03	2.2E+04	3.0E+03
	Cesium-137	pCi/g	78	147	8.2E-02	3.1E+00	4.5E+01	4.5E+00
	Chromium, Total	mg/kg	334	411	3.8E-01	2.9E+01	4.4E+02	3.7E+01
	Cobalt	mg/kg	102	145	5.2E-01	3.0E+00	1.6E+01	3.3E+00
	Cobalt-60	pCi/g	7	74	1.8E-01	7.4E-01	1.8E+00	1.3E+00
	Copper	mg/kg	123	145	1.6E+00	9.1E+00	1.7E+02	1.2E+01
	Europium-152	pCi/g	2	53	2.5E-01	3.2E-01	3.8E-01	4.5E-01
	Iron	mg/kg	132	144	2.1E+03	6.5E+03	2.2E+04	7.0E+03
	Lead	mg/kg	370	418	1.9E+00	5.2E+01	1.6E+03	6.4E+01
	Lead-210	pCi/g	1	12	7.9E+00	7.9E+00	7.9E+00	
	Lead-212	pCi/g	33	35	4.3E-01	1.5E+00	2.3E+00	1.6E+00
	Lead-214	pCi/g	22	35	7.1E-01	1.2E+00	1.8E+00	1.3E+00
	Lithium	mg/kg	24	109	5.7E+00	1.4E+01	2.5E+01	1.7E+01
	Magnesium	mg/kg	130	145	2.2E+02	8.9E+02	3.9E+03	9.9E+02
	Manganese	mg/kg	145	145	1.0E+02	2.6E+02	1.3E+03	2.8E+02
	Mercury	mg/kg	218	331	1.0E-04	1.9E+01	6.4E+02	2.8E+01
	Nickel	mg/kg	116	383	1.2E+00	8.0E+00	3.9E+01	9.4E+00
	Plutonium-238	pCi/g	107	451	5.0E-03	1.5E+00	4.4E+01	2.7E+00
	Plutonium-239	pCi/g	304	385	1.4E-02	9.7E+01	7.3E+03	1.6E+02
	Potassium	mg/kg	112	145	1.8E+02	8.3E+02	2.6E+03	9.0E+02
	Potassium-40	pCi/g	66	67	1.7E+01	2.6E+01	3.4E+01	2.7E+01
	Radium-224	pCi/g	1	33	1.4E+00	1.4E+00	1.4E+00	
	Radium-226	pCi/g	14	34	1.1E+00	1.8E+00	6.2E+00	2.5E+00
	Selenium	mg/kg	56	417	1.2E-01	2.7E+01	7.0E+01	3.3E+01
	Silicon	mg/kg	3	7	5.8E+01	6.9E+01	8.3E+01	8.4E+01
	Silver	mg/kg	34	383	5.2E-01	1.6E+01	1.5E+02	2.5E+01

TABLE C-9.—Soil Detection Statistics by Watershed and by Analyte (ER Risk Database [LANL 1998]—Inorganics and Radiochemistry)-Continued

WATERSHED	ANALYTE	UNITS	DETECTED	ANALYZED	MINIMUM	MEAN	MAXIMUM	UCL
Los Alamos Canyon (Cont.)	Sodium	mg/kg	82	144	2.8E+01	1.3E+02	5.7E+02	1.5E+02
	Strontium	mg/kg	98	109	4.8E+00	2.3E+01	1.3E+02	2.8E+01
	Strontium-90	pCi/g	4	122	1.8E-01	3.5E+00	1.2E+01	9.1E+00
	Thallium	mg/kg	21	392	2.0E-01	3.8E+01	1.7E+02	6.2E+01
	Thallium-208	pCi/g	29	34	2.8E-01	4.9E-01	8.1E-01	5.4E-01
	Thorium-228	pCi/g	5	5	7.3E-01	1.5E+00	2.3E+00	2.0E+00
	Thorium-230	pCi/g	5	5	5.7E-01	1.4E+00	1.9E+00	1.8E+00
	Thorium-232	pCi/g	5	5	7.0E-01	1.5E+00	2.1E+00	1.9E+00
	Thorium-234	pCi/g	1	33	6.6E+00	6.6E+00	6.6E+00	
	Tritium	pCi/g	11	12	1.8E-02	8.9E-02	1.8E-01	1.2E-01
	Uranium	mg/kg	14	253	3.7E-01	1.2E+00	2.2E+00	1.5E+00
	Uranium-234	pCi/g	155	155	3.4E-01	2.7E+00	4.4E+01	3.5E+00
	Uranium-235	pCi/g	53	177	3.2E-02	2.4E-01	1.3E+00	3.2E-01
	Uranium-238	pCi/g	155	155	3.0E-01	2.7E+00	3.9E+01	3.5E+00
	Vanadium	mg/kg	139	145	2.4E+00	9.9E+00	5.9E+01	1.1E+01
Zinc	mg/kg	141	145	1.3E+01	5.2E+01	3.7E+02	6.1E+01	
Mortandad Canyon	Actinium-228	pCi/g	23	25	8.1E-01	1.5E+00	7.2E+00	2.0E+00
	Aluminum	mg/kg	74	74	5.0E+02	6.0E+03	5.0E+04	7.8E+03
	Americium-241	pCi/g	23	100	7.1E-03	5.9E+00	2.4E+01	9.1E+00
	Antimony	mg/kg	23	100	8.5E-02	4.8E-01	1.6E+00	6.3E-01
	Arsenic	mg/kg	82	100	4.8E-01	2.0E+00	5.2E+00	2.2E+00
	Barium	mg/kg	102	102	1.1E+01	1.7E+02	4.6E+03	2.8E+02
	Beryllium	mg/kg	60	102	1.6E-01	1.4E+00	4.8E+01	3.0E+00
	Bismuth-212	pCi/g	1	25	3.8E+00	3.8E+00	3.8E+00	
	Bismuth-214	pCi/g	23	25	7.2E-01	1.1E+00	6.5E+00	1.6E+00
	Cadmium	mg/kg	17	102	1.2E-01	4.5E+00	5.4E+01	1.1E+01

TABLE C-9.—Soil Detection Statistics by Watershed and by Analyte (ER Risk Database [LANL 1998]—Inorganics and Radiochemistry)-Continued

WATERSHED	ANALYTE	UNITS	DETECTED	ANALYZED	MINIMUM	MEAN	MAXIMUM	UCL
Mortandad Canyon (Cont.)	Cadmium-109	pCi/g	6	25	2.2E+00	2.7E+00	3.8E+00	3.2E+00
	Calcium	mg/kg	73	73	2.1E+02	2.4E+03	5.7E+04	3.9E+03
	Cesium-137	pCi/g	49	79	4.7E-02	9.4E+00	7.8E+01	1.4E+01
	Chromium, Hexavalent	mg/kg	1	1	5.9E+00	5.9E+00	5.9E+00	
	Chromium, Total	mg/kg	90	102	8.8E-01	1.9E+01	4.5E+02	3.2E+01
	Cobalt	mg/kg	49	72	7.0E-01	2.4E+00	5.0E+00	2.7E+00
	Cobalt-60	pCi/g	14	79	9.3E-01	1.9E+00	3.2E+00	2.3E+00
	Copper	mg/kg	61	74	8.3E-01	2.7E+02	5.4E+03	5.2E+02
	Iron	mg/kg	74	74	1.4E+03	7.8E+03	5.0E+04	9.6E+03
	Lead	mg/kg	85	100	3.0E+00	4.4E+01	1.0E+03	7.5E+01
	Lead-212	pCi/g	25	25	1.1E+00	1.6E+00	8.2E+00	2.1E+00
	Lead-214	pCi/g	23	25	7.1E-01	1.2E+00	5.7E+00	1.6E+00
	Lithium	mg/kg	12	12	3.0E+00	7.0E+00	1.4E+01	9.4E+00
	Magnesium	mg/kg	73	73	1.3E+02	1.0E+03	8.8E+03	1.3E+03
	Manganese	mg/kg	74	74	5.9E+01	2.4E+02	1.6E+03	2.9E+02
	Mercury	mg/kg	16	63	4.0E-02	8.6E+00	4.6E+01	1.6E+01
	Molybdenum	mg/kg	2	12	1.8E+00	2.5E+00	3.2E+00	3.9E+00
	Nickel	mg/kg	86	102	1.3E+00	1.1E+01	5.3E+02	2.3E+01
	Plutonium-238	pCi/g	73	122	2.0E-03	1.3E+00	8.4E+00	1.9E+00
	Plutonium-239	pCi/g	76	108	5.0E-03	3.6E+00	2.8E+01	5.0E+00
	Potassium	mg/kg	74	74	1.5E+02	8.3E+02	5.6E+03	1.0E+03
	Potassium-40	pCi/g	54	54	2.1E+01	3.3E+01	2.2E+02	4.0E+01
	Protactinium-231	pCi/g	1	25	3.5E+00	3.5E+00	3.5E+00	
	Radium-224	pCi/g	3	25	1.7E+00	4.4E+00	8.9E+00	8.9E+00
	Radium-226	pCi/g	18	53	1.7E+00	2.8E+00	4.6E+00	3.1E+00
	Selenium	mg/kg	7	100	5.5E-01	8.0E-01	1.2E+00	9.8E-01

TABLE C-9.—Soil Detection Statistics by Watershed and by Analyte (ER Risk Database [LANL 1998]—Inorganics and Radiochemistry)-Continued

WATERSHED	ANALYTE	UNITS	DETECTED	ANALYZED	MINIMUM	MEAN	MAXIMUM	UCL
Mortandad Canyon (Cont.)	Silver	mg/kg	1	102	1.5E-01	1.5E-01	1.5E-01	
	Sodium	mg/kg	41	73	8.3E-01	1.7E+02	4.6E+02	2.0E+02
	Strontium	mg/kg	12	12	4.2E+00	2.3E+01	1.4E+02	4.5E+01
	Strontium-90	pCi/g	13	43	1.2E+00	2.0E+00	5.1E+00	2.6E+00
	Thallium	mg/kg	30	100	2.0E-02	1.1E-01	4.0E-01	1.4E-01
	Thallium-208	pCi/g	19	25	3.2E-01	5.9E-01	3.3E+00	9.0E-01
	Thorium-228	pCi/g	59	60	5.3E-01	1.2E+00	2.0E+00	1.3E+00
	Thorium-230	pCi/g	61	61	4.0E-01	9.4E-01	3.9E+00	1.1E+00
	Thorium-232	pCi/g	63	89	6.5E-01	1.3E+00	4.4E+00	1.5E+00
	Tritium	pCi/g	28	29	5.2E-02	8.6E+00	9.8E+01	1.7E+01
	Uranium-234	pCi/g	122	128	3.2E-01	1.7E+00	2.6E+01	2.1E+00
	Uranium-235	pCi/g	23	141	2.0E-02	1.3E-01	4.0E-01	1.7E-01
	Uranium-238	pCi/g	121	156	1.4E-01	1.7E+00	2.6E+01	2.2E+00
	Vanadium	mg/kg	74	74	1.1E+00	1.8E+01	6.0E+02	3.5E+01
Zinc	mg/kg	74	74	7.4E+00	6.4E+01	1.2E+03	1.0E+02	
Pajarito Canyon	Actinium-228	pCi/g	13	17	5.9E-01	1.0E+00	1.7E+00	1.2E+00
	Aluminum	mg/kg	118	118	5.4E+02	6.1E+03	2.6E+04	7.0E+03
	Antimony	mg/kg	3	117	1.8E+01	1.0E+02	2.7E+02	2.7E+02
	Arsenic	mg/kg	59	118	7.8E-01	5.8E+00	1.1E+02	9.6E+00
	Barium	mg/kg	109	118	2.4E+01	2.1E+02	2.1E+03	2.9E+02
	Beryllium	mg/kg	16	118	4.5E-01	7.9E-01	1.3E+00	9.5E-01
	Bismuth-211	pCi/g	4	17	6.1E-01	1.0E+00	1.6E+00	1.5E+00
	Bismuth-212	pCi/g	2	17	1.6E+00	2.1E+00	2.6E+00	3.1E+00
	Bismuth-214	pCi/g	14	17	1.6E-01	7.8E-01	2.4E+00	1.1E+00
	Cadmium	mg/kg	46	118	1.2E-01	5.0E+00	2.6E+01	6.7E+00
	Calcium	mg/kg	110	118	8.6E+02	6.8E+03	1.2E+05	1.0E+04

TABLE C-9.—Soil Detection Statistics by Watershed and by Analyte (ER Risk Database [LANL 1998]—Inorganics and Radiochemistry)-Continued

WATERSHED	ANALYTE	UNITS	DETECTED	ANALYZED	MINIMUM	MEAN	MAXIMUM	UCL
Pajarito Canyon (Cont.)	Cesium-137	pCi/g	22	31	7.1E-02	4.2E-01	1.9E+00	6.0E-01
	Chromium, Total	mg/kg	113	119	1.7E+00	9.1E+00	7.3E+01	1.1E+01
	Cobalt	mg/kg	18	118	1.1E+00	8.1E+00	2.5E+01	1.2E+01
	Cobalt-60	pCi/g	1	28	1.5E-01	1.5E-01	1.5E-01	
	Copper	mg/kg	92	118	2.7E+00	2.9E+02	1.0E+04	5.5E+02
	Cyanide, Total	mg/kg	10	40	5.2E-01	9.5E-01	4.2E+00	1.7E+00
	Iron	mg/kg	118	118	4.9E+02	1.2E+04	8.9E+04	1.4E+04
	Lead	mg/kg	117	117	3.1E+00	3.9E+02	1.2E+04	7.1E+02
	Lead-212	pCi/g	14	17	3.8E-01	1.0E+00	1.6E+00	1.2E+00
	Lead-214	pCi/g	12	17	4.1E-01	7.7E-01	1.1E+00	8.8E-01
	Magnesium	mg/kg	73	117	4.9E+02	2.0E+03	1.0E+04	2.4E+03
	Manganese	mg/kg	117	117	3.6E+00	3.5E+02	1.3E+03	3.9E+02
	Mercury	mg/kg	18	165	8.0E-02	2.0E+00	2.9E+01	5.1E+00
	Nickel	mg/kg	34	117	2.3E+00	2.3E+01	8.6E+01	3.1E+01
	Plutonium-238	pCi/g	8	18	1.0E-02	1.9E-01	1.0E+00	4.2E-01
	Plutonium-239	pCi/g	8	18	1.0E-02	1.1E-01	7.0E-01	2.8E-01
	Potassium	mg/kg	84	117	4.4E+02	1.4E+03	3.2E+03	1.6E+03
	Potassium-40	pCi/g	21	24	1.4E+01	2.5E+01	4.0E+01	2.8E+01
	Protactinium-234M	pCi/g	1	17	9.8E+00	9.8E+00	9.8E+00	
	Radium-224	pCi/g	12	17	1.2E+00	2.4E+00	5.8E+00	3.4E+00
	Radium-226	pCi/g	9	17	1.2E+00	2.0E+00	2.8E+00	2.3E+00
	Selenium	mg/kg	3	117	8.3E-01	1.2E+00	1.7E+00	1.7E+00
	Silver	mg/kg	23	119	1.0E+00	4.4E+01	1.8E+02	6.5E+01
	Sodium	mg/kg	12	117	7.4E+01	4.7E+02	1.5E+03	6.8E+02
	Sodium-22	pCi/g	1	28	1.3E-02	1.3E-02	1.3E-02	
	Strontium-90	pCi/g	2	15	6.7E-01	1.6E+00	2.5E+00	3.3E+00

TABLE C-9.—Soil Detection Statistics by Watershed and by Analyte (ER Risk Database [LANL 1998]—Inorganics and Radiochemistry)-Continued

WATERSHED	ANALYTE	UNITS	DETECTED	ANALYZED	MINIMUM	MEAN	MAXIMUM	UCL
Pajarito Canyon (Cont.)	Thallium-208	pCi/g	13	17	2.6E-01	3.6E-01	5.2E-01	4.0E-01
	Thorium-227	pCi/g	3	17	8.1E-01	9.0E-01	9.6E-01	9.8E-01
	Thorium-228	pCi/g	34	34	5.3E-02	1.1E+00	2.5E+00	1.3E+00
	Thorium-230	pCi/g	32	34	7.1E-02	1.2E+00	5.6E+00	1.6E+00
	Thorium-232	pCi/g	34	34	7.4E-02	1.1E+00	2.5E+00	1.3E+00
	Uranium	mg/kg	8	69	2.2E+00	3.3E+00	5.0E+00	4.0E+00
	Uranium-234	pCi/g	5	5	5.2E-01	3.1E+01	1.5E+02	9.1E+01
	Uranium-235	pCi/g	5	22	2.9E-02	1.4E+00	7.0E+00	4.2E+00
	Uranium-238	pCi/g	5	5	5.3E-01	3.1E+01	1.5E+02	9.0E+01
	Zinc	mg/kg	117	117	1.1E+01	2.6E+02	4.6E+03	3.8E+02
Pueblo Canyon (Part of Pueblo/ Acid Canyon)	Actinium-228	pCi/g	6	7	8.2E-01	1.6E+00	2.1E+00	2.0E+00
	Aluminum	mg/kg	7	7	8.8E+02	3.1E+03	4.8E+03	3.9E+03
	Arsenic	mg/kg	5	7	1.5E+00	1.8E+00	2.6E+00	2.2E+00
	Barium	mg/kg	7	7	1.5E+01	4.8E+01	8.9E+01	6.5E+01
	Beryllium	mg/kg	5	7	6.0E-01	7.0E-01	7.6E-01	7.6E-01
	Bismuth-214	pCi/g	6	7	1.0E+00	1.4E+00	2.1E+00	1.7E+00
	Cadmium-109	pCi/g	2	7	6.5E+00	6.7E+00	6.9E+00	7.0E+00
	Calcium	mg/kg	7	7	3.7E+02	1.5E+03	3.6E+03	2.2E+03
	Cesium-137	pCi/g	2	7	3.3E-01	4.5E-01	5.6E-01	6.8E-01
	Chromium, Total	mg/kg	7	7	1.3E+00	3.2E+00	5.3E+00	4.1E+00
	Cobalt	mg/kg	7	7	1.3E+00	2.3E+00	3.3E+00	2.8E+00
	Copper	mg/kg	7	7	3.9E+00	7.0E+00	9.7E+00	8.8E+00
	Iron	mg/kg	7	7	4.4E+03	6.0E+03	7.4E+03	6.8E+03
	Lead	mg/kg	7	7	6.4E+00	1.5E+01	2.4E+01	2.0E+01
Lead-212	pCi/g	7	7	6.0E-01	1.6E+00	2.4E+00	2.1E+00	

TABLE C-9.—Soil Detection Statistics by Watershed and by Analyte (ER Risk Database [LANL 1998]—Inorganics and Radiochemistry)-Continued

WATERSHED	ANALYTE	UNITS	DETECTED	ANALYZED	MINIMUM	MEAN	MAXIMUM	UCL
Pueblo Canyon (Part of Pueblo/ Acid Canyon) (Cont.)	Lead-214	pCi/g	7	7	4.2E-01	1.3E+00	2.2E+00	1.8E+00
	Magnesium	mg/kg	7	7	2.2E+02	6.7E+02	1.2E+03	8.8E+02
	Manganese	mg/kg	7	7	1.6E+02	2.6E+02	3.4E+02	3.0E+02
	Mercury	mg/kg	1	7	1.5E-01	1.5E-01	1.5E-01	
	Nickel	mg/kg	5	7	2.8E+00	3.6E+00	5.0E+00	4.4E+00
	Plutonium-238	pCi/g	1	51	2.0E-01	2.0E-01	2.0E-01	
	Plutonium-239	pCi/g	7	8	2.3E-01	1.1E+01	4.7E+01	2.4E+01
	Potassium	mg/kg	7	7	2.4E+02	8.3E+02	1.3E+03	1.1E+03
	Potassium-40	pCi/g	7	7	2.2E+01	2.6E+01	2.9E+01	2.8E+01
	Radium-226	pCi/g	2	6	3.6E+00	4.3E+00	5.1E+00	5.8E+00
	Selenium	mg/kg	4	7	5.0E-01	6.9E-01	9.8E-01	8.9E-01
	Sodium	mg/kg	2	7	1.5E+02	1.5E+02	1.5E+02	1.6E+02
	Thallium-208	pCi/g	6	7	3.7E-01	5.2E-01	7.6E-01	6.2E-01
	Vanadium	mg/kg	7	7	5.5E+00	7.6E+00	1.2E+01	9.1E+00
Zinc	mg/kg	7	7	2.8E+01	3.5E+01	4.4E+01	3.9E+01	
Rendija Canyon (Part of Guaje Canyon)	Aluminum	mg/kg	5	5	2.5E+03	6.3E+03	1.4E+04	1.1E+04
	Arsenic	mg/kg	3	5	1.1E+00	2.4E+00	3.9E+00	4.0E+00
	Barium	mg/kg	5	5	2.1E+01	5.6E+01	1.2E+02	9.9E+01
	Beryllium	mg/kg	5	5	2.0E-01	5.2E-01	1.0E+00	8.2E-01
	Calcium	mg/kg	5	5	1.0E+03	1.6E+03	2.2E+03	2.1E+03
	Chromium, Total	mg/kg	4	5	1.8E+00	6.0E+00	1.1E+01	1.1E+01
	Cobalt	mg/kg	2	5	5.0E+00	5.5E+00	6.0E+00	6.5E+00
	Copper	mg/kg	11	11	1.7E+00	4.4E+00	7.2E+00	5.5E+00
	Iron	mg/kg	5	5	2.6E+03	6.1E+03	1.2E+04	9.8E+03
	Lead	mg/kg	6	11	1.6E+00	8.2E+00	1.7E+01	1.3E+01
Magnesium	mg/kg	5	5	5.7E+02	1.2E+03	2.4E+03	1.9E+03	

TABLE C-9.—Soil Detection Statistics by Watershed and by Analyte (ER Risk Database [LANL 1998]—Inorganics and Radiochemistry)-Continued

WATERSHED	ANALYTE	UNITS	DETECTED	ANALYZED	MINIMUM	MEAN	MAXIMUM	UCL
Rendija Canyon (Part of Guaje Canyon) (Cont.)	Manganese	mg/kg	5	5	6.7E+01	1.9E+02	3.4E+02	3.1E+02
	Nickel	mg/kg	2	5	7.6E+00	8.8E+00	1.0E+01	1.1E+01
	Potassium	mg/kg	5	5	3.3E+02	9.4E+02	1.9E+03	1.5E+03
	Selenium	mg/kg	1	5	8.0E-01	8.0E-01	8.0E-01	
	Sodium	mg/kg	5	5	8.1E+01	2.3E+02	4.3E+02	3.9E+02
	Vanadium	mg/kg	5	5	4.0E+00	1.0E+01	2.2E+01	1.8E+01
	Zinc	mg/kg	11	11	1.8E+01	3.1E+01	8.0E+01	4.2E+01
Rio Grande	Aluminum	mg/kg	6	6	3.0E+03	4.4E+03	6.9E+03	5.5E+03
	Arsenic	mg/kg	3	6	2.6E+00	1.8E+01	3.0E+01	3.4E+01
	Barium	mg/kg	6	6	5.4E+01	2.4E+02	5.3E+02	4.2E+02
	Cadmium	mg/kg	3	6	2.2E+00	2.6E+00	3.1E+00	3.1E+00
	Calcium	mg/kg	5	6	1.1E+03	2.4E+03	3.7E+03	3.5E+03
	Chromium, Total	mg/kg	5	6	2.6E+00	3.3E+00	3.9E+00	3.7E+00
	Copper	mg/kg	3	6	5.6E+00	6.5E+00	7.2E+00	7.4E+00
	Iron	mg/kg	6	6	4.0E+03	6.0E+03	8.2E+03	7.1E+03
	Lead	mg/kg	6	6	7.6E+00	5.5E+01	1.9E+02	1.1E+02
	Magnesium	mg/kg	1	6	1.3E+03	1.3E+03	1.3E+03	
	Manganese	mg/kg	6	6	2.5E+02	4.1E+02	8.6E+02	6.1E+02
	Mercury	mg/kg	3	6	4.3E-01	7.4E-01	1.1E+00	1.1E+00
	Potassium	mg/kg	1	6	1.4E+03	1.4E+03	1.4E+03	
	Zinc	mg/kg	6	6	3.5E+01	4.1E+01	5.2E+01	4.6E+01
Sandia Canyon	Actinium-228	pCi/g	12	13	1.1E+00	1.6E+00	2.1E+00	1.8E+00
	Aluminum	mg/kg	105	105	5.9E+02	5.8E+03	1.5E+04	6.2E+03
	Americium-241	pCi/g	1	60	6.8E-02	6.8E-02	6.8E-02	
	Antimony	mg/kg	37	135	3.0E-02	5.4E-01	5.5E+00	9.2E-01
	Arsenic	mg/kg	79	132	4.8E-01	3.5E+00	1.9E+01	4.1E+00

TABLE C-9.—Soil Detection Statistics by Watershed and by Analyte (ER Risk Database [LANL 1998]—Inorganics and Radiochemistry)-Continued

WATERSHED	ANALYTE	UNITS	DETECTED	ANALYZED	MINIMUM	MEAN	MAXIMUM	UCL
Sandia Canyon (Cont.)	Barium	mg/kg	117	132	2.3E+01	9.9E+01	3.4E+02	1.1E+02
	Beryllium	mg/kg	76	133	1.2E-01	6.9E-01	2.3E+00	7.8E-01
	Bismuth-211	pCi/g	8	13	3.6E+00	4.2E+00	4.9E+00	4.5E+00
	Bismuth-212	pCi/g	1	8	1.9E+00	1.9E+00	1.9E+00	
	Bismuth-214	pCi/g	11	13	1.2E+00	1.5E+00	2.2E+00	1.7E+00
	Cadmium	mg/kg	54	132	1.4E-01	3.2E+00	3.0E+01	4.5E+00
	Cadmium-109	pCi/g	3	4	1.7E+00	3.6E+00	4.7E+00	5.6E+00
	Calcium	mg/kg	97	105	5.5E+02	3.1E+03	1.6E+04	3.6E+03
	Cesium-137	pCi/g	40	87	6.7E-02	4.0E-01	2.4E+00	5.5E-01
	Chromium, Total	mg/kg	121	132	1.5E+00	2.2E+01	2.4E+02	3.0E+01
	Cobalt	mg/kg	51	105	9.5E-01	3.5E+00	7.2E+00	3.9E+00
	Cobalt-60	pCi/g	1	60	7.0E-02	7.0E-02	7.0E-02	
	Copper	mg/kg	106	124	1.8E+00	7.6E+01	5.7E+02	1.0E+02
	Cyanide, Total	mg/kg	5	25	9.3E-01	1.2E+01	3.4E+01	2.5E+01
	Europium-152	pCi/g	6	56	2.1E-01	3.0E-01	4.4E-01	3.7E-01
	Iron	mg/kg	104	104	2.9E+03	7.4E+03	1.7E+04	7.9E+03
	Lead	mg/kg	135	135	3.4E+00	7.1E+01	1.6E+03	1.1E+02
	Lead-212	pCi/g	12	13	9.6E-01	1.6E+00	1.9E+00	1.7E+00
	Lead-214	pCi/g	12	13	7.6E-01	1.7E+00	2.6E+00	2.0E+00
	Magnesium	mg/kg	79	105	4.9E+02	1.4E+03	3.6E+03	1.5E+03
	Manganese	mg/kg	124	124	5.4E+01	2.2E+02	1.4E+03	2.4E+02
	Mercury	mg/kg	85	155	2.4E-03	1.5E+02	5.7E+03	3.0E+02
	Nickel	mg/kg	68	132	2.5E+00	8.5E+00	4.4E+01	1.0E+01
	Plutonium-238	pCi/g	29	42	2.0E-03	4.1E-02	2.1E-01	6.2E-02
	Plutonium-239	pCi/g	32	36	5.0E-03	3.0E-01	1.4E+00	4.3E-01
	Potassium	mg/kg	62	105	3.1E+02	1.2E+03	2.0E+03	1.3E+03

TABLE C-9.—Soil Detection Statistics by Watershed and by Analyte (ER Risk Database [LANL 1998]—Inorganics and Radiochemistry)-Continued

WATERSHED	ANALYTE	UNITS	DETECTED	ANALYZED	MINIMUM	MEAN	MAXIMUM	UCL
Sandia Canyon (Cont.)	Potassium-40	pCi/g	12	13	3.0E+01	3.3E+01	3.9E+01	3.5E+01
	Protactinium-234M	pCi/g	3	8	4.6E+01	5.4E+01	6.5E+01	6.5E+01
	Radium-226	pCi/g	7	10	8.7E-01	2.3E+00	4.4E+00	3.5E+00
	Selenium	mg/kg	29	132	1.6E-01	9.9E-01	2.6E+00	1.2E+00
	Silver	mg/kg	37	132	5.6E-01	2.6E+01	1.1E+02	3.6E+01
	Sodium	mg/kg	45	105	4.1E+01	1.9E+02	8.4E+02	2.4E+02
	Strontium-90	pCi/g	1	60	6.6E-01	6.6E-01	6.6E-01	
	Thallium	mg/kg	35	132	1.4E-01	4.5E-01	2.2E+00	5.7E-01
	Thallium-208	pCi/g	12	13	3.0E-01	5.2E-01	6.7E-01	5.8E-01
	Thorium-234	pCi/g	10	12	2.9E+00	1.0E+01	3.6E+01	1.8E+01
	Tritium	pCi/g	23	23	3.2E-02	8.3E+01	5.6E+02	1.6E+02
	Tritium		6	0				
	Uranium	mg/kg	47	48	1.5E+00	6.0E+00	6.9E+01	9.8E+00
	Uranium-234	pCi/g	67	69	4.8E-01	2.3E+00	3.5E+01	3.7E+00
	Uranium-235	pCi/g	46	73	1.1E-02	2.8E-01	2.0E+00	4.3E-01
	Uranium-238	mg/kg	1	1	5.3E-04	5.3E-04	5.3E-04	
	Uranium-238	pCi/g	64	68	5.0E-01	1.1E+00	2.6E+00	1.3E+00
	Vanadium	mg/kg	93	124	4.3E+00	1.7E+01	3.4E+01	1.8E+01
Zinc	mg/kg	124	124	2.2E-02	1.2E+02	8.4E+02	1.5E+02	
Starmer's Gulch (Part of Pajarito Canyon)	Aluminum	mg/kg	37	37	4.4E+03	7.7E+03	1.6E+04	8.5E+03
	Arsenic	mg/kg	16	37	2.2E+00	7.3E+00	2.1E+01	1.0E+01
	Barium	mg/kg	43	47	4.7E+01	1.9E+02	5.3E+02	2.2E+02
	Beryllium	mg/kg	10	47	1.9E-01	3.4E-01	5.0E-01	4.0E-01
	Cadmium	mg/kg	13	49	1.6E+00	1.5E+01	4.3E+01	2.2E+01
	Calcium	mg/kg	34	37	1.2E+03	2.7E+03	8.4E+03	3.4E+03
	Cesium-137	pCi/g	4	5	1.6E-01	2.9E-01	4.0E-01	4.0E-01

TABLE C-9.—Soil Detection Statistics by Watershed and by Analyte (ER Risk Database [LANL 1998]—Inorganics and Radiochemistry)-Continued

WATERSHED	ANALYTE	UNITS	DETECTED	ANALYZED	MINIMUM	MEAN	MAXIMUM	UCL
Starmer's Gulch (Part of Pajarito Canyon) (Cont.)	Chromium, Hexavalent	mg/kg	2	5	1.7E-01	1.8E-01	1.9E-01	2.0E-01
	Chromium, Total	mg/kg	49	49	3.5E+00	6.0E+01	5.9E+02	9.7E+01
	Cobalt	mg/kg	7	37	3.1E+00	8.8E+00	1.7E+01	1.3E+01
	Copper	mg/kg	35	37	6.0E+00	1.1E+03	1.2E+04	2.0E+03
	Cyanide, Total	mg/kg	3	21	1.0E+00	1.1E+00	1.1E+00	1.1E+00
	Iron	mg/kg	37	37	6.4E+03	1.2E+04	5.2E+04	1.5E+04
	Lead	mg/kg	43	49	7.6E+00	6.7E+01	4.2E+02	9.3E+01
	Magnesium	mg/kg	31	37	7.0E+02	1.4E+03	2.7E+03	1.6E+03
	Manganese	mg/kg	37	37	8.2E+01	3.5E+02	9.9E+02	4.2E+02
	Mercury	mg/kg	9	47	4.0E-02	2.1E-01	5.6E-01	3.2E-01
	Nickel	mg/kg	10	37	1.4E+02	8.2E+02	1.5E+03	1.1E+03
	Platinum	mg/kg	5	5	1.7E+01	2.0E+01	2.2E+01	2.1E+01
	Potassium	mg/kg	27	37	6.9E+02	1.4E+03	2.8E+03	1.5E+03
	Silver	mg/kg	14	39	2.5E+00	1.2E+01	3.4E+01	1.7E+01
	Sodium	mg/kg	6	37	1.0E+02	1.3E+02	1.6E+02	1.5E+02
	Strontium-90	pCi/g	6	9	7.1E-01	1.0E+00	1.7E+00	1.4E+00
	Thallium	mg/kg	1	37	1.9E+00	1.9E+00	1.9E+00	
Vanadium	mg/kg	36	37	1.3E+01	2.3E+01	8.8E+01	2.8E+01	
Zinc	mg/kg	36	37	2.2E+01	8.0E+01	2.1E+02	9.8E+01	
Ten-Site Canyon (Part of Mortandad Canyon)	Actinium-228	pCi/g	37	61	4.2E-01	1.4E+00	2.2E+00	1.5E+00
	Aluminum	mg/kg	108	108	1.6E+02	5.1E+03	1.5E+04	5.9E+03
	Americium-241	pCi/g	55	356	8.0E-03	3.6E+00	1.7E+02	9.8E+00
	Antimony	mg/kg	23	266	3.0E-02	8.1E-01	8.2E+00	1.7E+00
	Arsenic	mg/kg	215	267	2.4E-01	2.3E+00	1.2E+01	2.5E+00
	Barium	mg/kg	249	266	5.4E-01	8.9E+01	8.0E+02	9.8E+01
	Beryllium	mg/kg	212	266	6.0E-02	1.4E+00	1.5E+02	2.8E+00

TABLE C-9.—Soil Detection Statistics by Watershed and by Analyte (ER Risk Database [LANL 1998]—Inorganics and Radiochemistry)-Continued

WATERSHED	ANALYTE	UNITS	DETECTED	ANALYZED	MINIMUM	MEAN	MAXIMUM	UCL
Ten-Site Canyon (Part of Mortandad Canyon) (Cont.)	Bismuth-211	pCi/g	7	61	1.6E+00	2.6E+00	3.7E+00	3.3E+00
	Bismuth-214	pCi/g	43	61	4.8E-01	9.1E-01	1.3E+00	9.8E-01
	Cadmium	mg/kg	42	266	3.6E-02	7.6E+00	1.7E+02	1.7E+01
	Calcium	mg/kg	107	108	1.6E+02	2.5E+03	1.1E+04	2.8E+03
	Cesium-137	pCi/g	58	292	1.2E-01	3.3E+00	7.3E+01	6.7E+00
	Chromium, Hexavalent	mg/kg	2	5	9.8E-01	1.7E+00	2.5E+00	3.3E+00
	Chromium, Total	mg/kg	256	267	1.1E+00	1.2E+01	8.1E+02	1.9E+01
	Cobalt	mg/kg	62	108	3.3E-01	3.2E+00	1.1E+01	3.6E+00
	Cobalt-60	pCi/g	8	292	1.0E-01	6.9E-01	1.5E+00	1.1E+00
	Copper	mg/kg	100	108	1.1E+00	2.6E+01	4.3E+02	3.7E+01
	Europium-152	pCi/g	3	134	3.6E-01	4.2E-01	4.7E-01	4.8E-01
	Iron	mg/kg	108	108	4.6E+02	6.6E+03	1.5E+04	7.3E+03
	Lead	mg/kg	249	272	1.1E+00	1.5E+01	9.8E+01	1.6E+01
	Lead-210	pCi/g	3	19	3.2E+00	4.7E+00	5.6E+00	6.3E+00
	Lead-212	pCi/g	59	62	1.9E-01	1.3E+00	3.3E+00	1.4E+00
	Lead-214	pCi/g	49	62	4.0E-01	9.2E-01	1.5E+00	1.0E+00
	Lithium	mg/kg	2	4	6.5E+00	6.7E+00	6.8E+00	7.0E+00
	Magnesium	mg/kg	102	108	4.0E+01	1.0E+03	2.7E+03	1.1E+03
	Manganese	mg/kg	108	108	1.7E+00	1.8E+02	3.7E+02	1.9E+02
	Mercury	mg/kg	36	168	2.0E-02	4.2E-01	4.0E+00	6.7E-01
	Nickel	mg/kg	187	266	2.0E+00	1.2E+01	8.7E+02	2.1E+01
	Plutonium-238	pCi/g	114	328	3.0E-03	4.8E+01	5.2E+03	1.4E+02
	Plutonium-239	pCi/g	185	262	2.0E-03	3.4E+00	4.5E+02	8.3E+00
	Potassium	mg/kg	102	110	6.9E+01	9.4E+02	3.1E+03	1.1E+03
Potassium-40	pCi/g	228	282	7.0E+00	2.7E+01	4.7E+01	2.8E+01	
Radium-224	pCi/g	7	61	4.6E+00	1.3E+01	1.5E+01	1.5E+01	

TABLE C-9.—Soil Detection Statistics by Watershed and by Analyte (ER Risk Database [LANL 1998]—Inorganics and Radiochemistry)-Continued

WATERSHED	ANALYTE	UNITS	DETECTED	ANALYZED	MINIMUM	MEAN	MAXIMUM	UCL
Ten-Site Canyon (Part of Mortandad Canyon) (Cont.)	Radium-226	pCi/g	55	223	1.5E+00	3.2E+00	6.7E+00	3.5E+00
	Ruthenium-106	pCi/g	1	132	5.6E-01	5.6E-01	5.6E-01	
	Selenium	mg/kg	18	267	2.3E-01	5.9E-01	1.0E+00	6.8E-01
	Silver	mg/kg	25	266	3.9E-01	2.8E+01	4.1E+02	6.1E+01
	Sodium	mg/kg	91	108	2.6E+01	1.5E+02	3.7E+02	1.7E+02
	Strontium	mg/kg	3	4	3.8E+00	1.1E+01	1.5E+01	1.8E+01
	Strontium-90	pCi/g	12	223	1.2E+00	1.1E+02	9.0E+02	2.6E+02
	Thallium	mg/kg	122	268	3.0E-02	1.4E+00	1.4E+02	3.7E+00
	Thallium-208	pCi/g	40	62	1.7E-01	5.3E-01	1.6E+00	6.3E-01
	Thorium-227	pCi/g	3	61	2.0E+00	2.1E+00	2.2E+00	2.2E+00
	Thorium-228	pCi/g	5	5	1.9E-01	4.7E-01	7.2E-01	7.0E-01
	Thorium-230	pCi/g	4	5	2.9E-01	6.3E-01	8.2E-01	8.7E-01
	Thorium-232	pCi/g	27	164	2.1E-01	2.9E+00	4.8E+00	3.4E+00
	Tritium	pCi/g	185	217	4.7E-03	2.0E+00	1.8E+02	4.1E+00
	Uranium-234	pCi/g	328	383	1.6E-01	1.4E+00	4.9E+01	1.8E+00
	Uranium-235	pCi/g	56	521	2.0E-02	1.4E-01	1.5E+00	2.1E-01
	Uranium-238	pCi/g	328	435	1.5E-01	1.2E+00	3.6E+00	1.2E+00
	Vanadium	mg/kg	94	108	8.6E-01	1.3E+01	6.9E+01	1.5E+01
Zinc	mg/kg	105	105	3.9E+00	7.2E+01	7.5E+02	9.6E+01	
Three-Mile Canyon (Part of Pajarito Canyon)	Actinium-228	pCi/g	2	2	1.5E+00	1.7E+00	1.8E+00	1.9E+00
	Aluminum	mg/kg	145	145	6.1E+02	6.1E+03	9.7E+04	7.5E+03
	Antimony	mg/kg	25	145	1.1E-01	3.1E+00	1.8E+01	5.5E+00
	Arsenic	mg/kg	59	145	1.7E+00	1.2E+01	5.2E+02	2.9E+01
	Barium	mg/kg	130	145	2.8E+01	1.1E+02	8.7E+02	1.3E+02
	Beryllium	mg/kg	67	146	3.2E-01	7.3E+00	1.0E+02	1.1E+01
	Bismuth-211	pCi/g	2	2	6.0E-01	1.1E+00	1.6E+00	2.0E+00

TABLE C-9.—Soil Detection Statistics by Watershed and by Analyte (ER Risk Database [LANL 1998]—Inorganics and Radiochemistry)-Continued

WATERSHED	ANALYTE	UNITS	DETECTED	ANALYZED	MINIMUM	MEAN	MAXIMUM	UCL
Three-Mile Canyon (Part of Pajarito Canyon) (Cont.)	Bismuth-212	pCi/g	1	2	2.3E+00	2.3E+00	2.3E+00	
	Bismuth-214	pCi/g	2	2	1.1E+00	1.2E+00	1.3E+00	1.3E+00
	Cadmium	mg/kg	38	145	1.3E-02	6.8E-01	2.7E+00	9.6E-01
	Calcium	mg/kg	138	145	5.3E+02	2.6E+03	2.0E+04	3.0E+03
	Cesium-137	pCi/g	12	17	6.4E-02	5.5E-01	2.5E+00	9.3E-01
	Chromium, Total	mg/kg	140	144	1.3E+00	2.4E+01	8.8E+02	3.9E+01
	Cobalt	mg/kg	31	145	1.8E+00	5.4E+00	1.3E+01	6.2E+00
	Copper	mg/kg	126	145	2.8E+00	4.7E+02	7.2E+03	6.7E+02
	Cyanide, Total	mg/kg	3	5	1.6E+00	4.5E+01	1.3E+02	1.3E+02
	Europium-152	pCi/g	1	14	2.6E-01	2.6E-01	2.6E-01	
	Iron	mg/kg	145	145	1.0E+03	8.4E+03	9.8E+04	9.9E+03
	Lead	mg/kg	146	147	2.4E+00	1.0E+03	1.3E+05	2.8E+03
	Lead-212	pCi/g	4	4	1.5E+00	1.6E+00	1.8E+00	1.7E+00
	Lead-214	pCi/g	4	4	8.8E-01	1.2E+00	1.4E+00	1.4E+00
	Magnesium	mg/kg	100	145	3.8E+02	1.2E+03	2.8E+03	1.3E+03
	Manganese	mg/kg	145	145	6.5E+01	2.7E+02	1.3E+03	3.0E+02
	Mercury	mg/kg	36	207	5.1E-03	3.9E-01	2.8E+00	6.4E-01
	Nickel	mg/kg	46	145	4.3E+00	2.9E+01	4.1E+02	5.0E+01
	Plutonium-238	pCi/g	5	10	9.0E-03	1.8E-02	3.0E-02	2.5E-02
	Plutonium-239	pCi/g	1	10	7.0E-03	7.0E-03	7.0E-03	
	Potassium	mg/kg	104	145	2.6E+02	1.1E+03	2.8E+03	1.2E+03
	Potassium-40	pCi/g	4	4	2.0E+01	2.5E+01	2.9E+01	2.9E+01
	Protactinium-231	pCi/g	1	17	4.9E+00	4.9E+00	4.9E+00	
	Protactinium-234	pCi/g	1	17	8.2E-01	8.2E-01	8.2E-01	
Protactinium-234M	pCi/g	1	17	5.6E+02	5.6E+02	5.6E+02		
Radium-224	pCi/g	2	2	2.1E+00	2.5E+00	2.9E+00	3.2E+00	

TABLE C-9.—Soil Detection Statistics by Watershed and by Analyte (ER Risk Database [LANL 1998]—Inorganics and Radiochemistry)-Continued

WATERSHED	ANALYTE	UNITS	DETECTED	ANALYZED	MINIMUM	MEAN	MAXIMUM	UCL
Three-Mile Canyon (Part of Pajarito Canyon) (Cont.)	Radium-226	pCi/g	4	4	9.6E-01	1.6E+00	2.9E+00	2.5E+00
	Ruthenium-106	pCi/g	1	16	6.6E-01	6.6E-01	6.6E-01	
	Selenium	mg/kg	11	145	1.4E-01	9.5E-01	2.0E+00	1.3E+00
	Silver	mg/kg	14	145	3.1E+00	1.1E+02	4.1E+02	1.9E+02
	Sodium	mg/kg	25	145	5.4E+01	1.4E+02	7.8E+02	2.1E+02
	Thallium	mg/kg	3	145	2.0E-01	2.2E+00	4.6E+00	4.8E+00
	Thallium-208	pCi/g	3	3	4.5E-01	5.2E-01	6.0E-01	6.1E-01
	Thorium-228	pCi/g	29	29	1.8E-01	1.1E+00	3.0E+00	1.3E+00
	Thorium-230	pCi/g	44	44	1.2E-01	1.0E+00	1.8E+00	1.1E+00
	Thorium-231	pCi/g	1	15	9.0E-01	9.0E-01	9.0E-01	
	Thorium-232	pCi/g	29	29	1.4E-01	1.1E+00	2.4E+00	1.2E+00
	Thorium-234	pCi/g	15	17	2.9E+00	2.2E+01	2.8E+02	5.9E+01
	Tritium	pCi/g	27	32	3.9E-01	1.1E+01	3.8E+01	1.5E+01
	Uranium-234	pCi/g	20	20	9.1E-01	1.4E+00	1.8E+00	1.5E+00
	Uranium-235	pCi/g	8	22	4.1E-02	2.3E+00	1.7E+01	6.4E+00
	Uranium-238	pCi/g	11	20	8.6E-01	2.7E+01	2.6E+02	7.5E+01
	Vanadium	mg/kg	97	145	4.5E+00	1.2E+01	2.8E+01	1.4E+01
Zinc	mg/kg	145	145	1.2E+01	9.5E+01	2.9E+03	1.4E+02	
Two-Mile Canyon (Part of Pajarito Canyon)	Acetone	mg/kg	1	61	2.2E-02	2.2E-02	2.2E-02	
	Actinium-228	pCi/g	2	16	1.6E+00	1.8E+00	2.0E+00	2.2E+00
	Aluminum	mg/kg	267	267	1.2E+03	6.9E+03	2.5E+04	7.4E+03
	Antimony	mg/kg	19	273	1.0E-01	7.7E+00	2.3E+01	1.1E+01
	Arsenic	mg/kg	201	273	3.7E-01	5.5E+00	1.7E+02	7.5E+00
	Barium	mg/kg	254	273	2.8E+01	3.2E+02	1.6E+04	5.1E+02
	Beryllium	mg/kg	106	274	1.0E-01	6.4E-01	3.3E+00	7.2E-01
	Bismuth-214	pCi/g	1	16	1.5E+00	1.5E+00	1.5E+00	

TABLE C-9.—Soil Detection Statistics by Watershed and by Analyte (ER Risk Database [LANL 1998]—Inorganics and Radiochemistry)-Continued

WATERSHED	ANALYTE	UNITS	DETECTED	ANALYZED	MINIMUM	MEAN	MAXIMUM	UCL
Two-Mile Canyon (Part of Pajarito Canyon) (Cont.)	Cadmium	mg/kg	82	273	5.0E-02	8.5E+00	1.4E+02	1.3E+01
	Calcium	mg/kg	249	267	6.1E+02	4.3E+03	1.9E+05	6.2E+03
	Cesium-137	pCi/g	119	159	3.9E-02	7.9E-01	5.4E+00	9.1E-01
	Chromium, Total	mg/kg	268	273	1.2E+00	5.0E+01	1.7E+03	7.3E+01
	Cobalt	mg/kg	110	267	7.7E-01	6.0E+00	2.3E+01	6.8E+00
	Copper	mg/kg	234	273	1.1E+00	5.5E+02	2.8E+04	8.9E+02
	Cyanide, Total	mg/kg	24	160	3.8E-01	2.0E+00	6.6E+00	2.8E+00
	Fluorine	mg/kg	12	12	2.0E+00	5.2E+00	1.1E+01	7.0E+00
	Gold	mg/kg	5	25	7.1E+00	7.0E+02	3.1E+03	1.9E+03
	Iron	mg/kg	267	267	1.4E+03	1.1E+04	2.2E+05	1.3E+04
	Lead	mg/kg	273	273	1.0E+00	1.1E+02	7.3E+03	1.8E+02
	Lead-212	pCi/g	4	16	7.8E-01	1.3E+00	1.7E+00	1.7E+00
	Lead-214	pCi/g	4	16	5.3E-01	1.0E+00	1.4E+00	1.3E+00
	Magnesium	mg/kg	218	267	3.8E+02	1.4E+03	4.3E+03	1.5E+03
	Manganese	mg/kg	273	273	1.7E+01	3.4E+02	4.0E+03	3.7E+02
	Mercury	mg/kg	39	278	5.0E-02	1.2E+01	1.2E+02	2.0E+01
	Nickel	mg/kg	147	273	1.4E+00	1.1E+02	1.6E+03	1.6E+02
	Platinum	mg/kg	17	25	1.4E+01	4.6E+01	1.9E+02	6.7E+01
	Plutonium-238	pCi/g	2	7	1.4E-02	2.1E-02	2.8E-02	3.5E-02
	Plutonium-239	pCi/g	5	7	3.8E-02	6.1E-01	1.6E+00	1.1E+00
	Potassium	mg/kg	195	267	1.0E+02	1.3E+03	3.1E+03	1.4E+03
	Potassium-40	pCi/g	5	19	3.3E+01	3.4E+01	3.6E+01	3.5E+01
	Radium-226	pCi/g	6	16	5.6E-01	1.0E+00	1.4E+00	1.3E+00
	Selenium	mg/kg	27	273	2.2E-01	9.5E-01	5.7E+00	1.3E+00
	Silver	mg/kg	55	273	1.4E+00	2.3E+01	2.7E+02	3.4E+01
	Sodium	mg/kg	103	267	3.3E+01	1.1E+02	8.0E+02	1.3E+02

TABLE C-9.—Soil Detection Statistics by Watershed and by Analyte (ER Risk Database [LANL 1998]—Inorganics and Radiochemistry)-Continued

WATERSHED	ANALYTE	UNITS	DETECTED	ANALYZED	MINIMUM	MEAN	MAXIMUM	UCL
Two-Mile Canyon (Part of Pajarito Canyon)	Strontium-90	pCi/g	35	153	1.7E-01	9.8E-01	8.4E+00	1.5E+00
	Thallium	mg/kg	15	273	1.2E-01	2.9E-01	5.5E-01	3.7E-01
	Thallium-208	pCi/g	10	16	2.0E-01	5.0E-01	6.5E-01	5.8E-01
	Thorium-234	pCi/g	1	16	4.1E+00	4.1E+00	4.1E+00	
	Tritium	pCi/g	6	6	2.2E-02	1.2E+01	3.5E+01	2.4E+01
	Uranium	mg/kg	21	22	1.4E+00	4.5E+00	9.3E+00	5.6E+00
	Uranium-234	pCi/g	80	80	3.7E-01	1.1E+00	1.2E+01	1.4E+00
	Uranium-235	pCi/g	76	96	2.0E-02	4.9E-02	4.8E-01	6.0E-02
	Uranium-238	pCi/g	80	80	3.6E-01	1.2E+00	1.2E+01	1.4E+00
	Vanadium	mg/kg	230	273	3.5E+00	2.2E+01	2.3E+02	2.4E+01
	Zinc	mg/kg	269	273	4.9E+00	1.7E+02	1.5E+04	2.8E+02
Walnut Canyon (Part of Pueblo/Acid Canyon)	Aluminum	mg/kg	5	5	1.7E+03	2.0E+03	2.6E+03	2.3E+03
	Americium-241	pCi/g	1	2	4.3E-01	4.3E-01	4.3E-01	
	Arsenic	mg/kg	5	5	1.1E+00	1.3E+00	1.6E+00	1.5E+00
	Barium	mg/kg	5	5	1.7E+01	3.1E+01	5.0E+01	4.4E+01
	Beryllium	mg/kg	2	5	1.9E-01	2.1E-01	2.2E-01	2.4E-01
	Cadmium	mg/kg	2	5	2.0E-01	2.1E-01	2.2E-01	2.3E-01
	Calcium	mg/kg	5	5	6.7E+02	9.9E+02	1.7E+03	1.4E+03
	Cesium-137	pCi/g	5	5	2.5E-01	3.6E-01	5.6E-01	4.8E-01
	Chromium, Total	mg/kg	4	5	3.1E+00	3.6E+00	4.9E+00	4.5E+00
	Cobalt	mg/kg	4	5	2.2E+00	3.0E+00	4.4E+00	3.9E+00
	Copper	mg/kg	2	2	6.7E+00	7.7E+00	8.7E+00	9.7E+00
	Iron	mg/kg	5	5	4.6E+03	6.4E+03	7.6E+03	7.5E+03
	Lead	mg/kg	5	5	2.5E+01	2.7E+01	3.2E+01	3.0E+01
	Magnesium	mg/kg	5	5	3.5E+02	4.5E+02	5.6E+02	5.3E+02
	Manganese	mg/kg	2	2	2.3E+02	3.3E+02	4.3E+02	5.3E+02

TABLE C-9.—Soil Detection Statistics by Watershed and by Analyte (ER Risk Database [LANL 1998]—Inorganics and Radiochemistry)-Continued

WATERSHED	ANALYTE	UNITS	DETECTED	ANALYZED	MINIMUM	MEAN	MAXIMUM	UCL
Walnut Canyon (Part of Pueblo/ Acid Canyon) (Cont.)	Mercury	mg/kg	2	5	6.0E-02	1.9E-01	3.2E-01	4.5E-01
	Nickel	mg/kg	2	5	1.0E+00	1.1E+00	1.2E+00	1.3E+00
	Plutonium-238	pCi/g	1	16	1.4E-01	1.4E-01	1.4E-01	
	Plutonium-239	pCi/g	3	3	5.2E+00	6.8E+00	8.4E+00	8.7E+00
	Potassium	mg/kg	2	5	3.7E+02	4.8E+02	5.9E+02	7.0E+02
	Potassium-40	pCi/g	2	2	2.7E+01	2.8E+01	2.9E+01	3.0E+01
	Silver	mg/kg	1	5	6.7E-01	6.7E-01	6.7E-01	
	Sodium	mg/kg	5	5	3.8E+01	8.8E+01	1.4E+02	1.3E+02
	Tritium	pCi/g	2	6	2.2E-02	2.3E-02	2.4E-02	2.5E-02
	Uranium-234	pCi/g	3	3	4.8E-01	6.1E-01	7.4E-01	7.6E-01
	Uranium-238	pCi/g	3	3	5.0E-01	5.1E-01	5.5E-01	5.5E-01
	Vanadium	mg/kg	5	5	5.6E+00	7.8E+00	9.2E+00	9.1E+00
Zinc	mg/kg	5	5	3.4E+01	4.5E+01	5.8E+01	5.4E+01	
Water Canyon	Actinium-228	pCi/g	17	24	5.8E-01	1.6E+00	2.5E+00	1.8E+00
	Aluminum	mg/kg	587	587	9.1E+02	7.9E+03	3.4E+04	8.3E+03
	Americium-241	pCi/g	3	112	2.0E-01	3.3E+00	5.8E+00	6.6E+00
	Antimony	mg/kg	118	587	3.8E-02	1.3E+00	1.4E+01	1.7E+00
	Arsenic	mg/kg	494	587	4.4E-01	2.7E+00	2.1E+01	2.8E+00
	Barium	mg/kg	564	587	2.4E+00	1.2E+03	3.8E+04	1.5E+03
	Beryllium	mg/kg	401	614	1.1E-01	1.7E+00	2.6E+02	3.0E+00
	Bismuth-211	pCi/g	8	18	3.1E-01	2.4E+00	3.9E+00	3.4E+00
	Bismuth-212	pCi/g	3	19	1.0E+00	1.2E+00	1.6E+00	1.6E+00
	Bismuth-214	pCi/g	13	20	1.2E-01	1.4E+00	3.4E+00	1.9E+00
	Cadmium	mg/kg	168	586	1.9E-02	1.0E+00	1.3E+01	1.2E+00
	Cadmium-109	pCi/g	1	10	4.9E+00	4.9E+00	4.9E+00	
	Calcium	mg/kg	556	587	3.1E+02	2.6E+03	3.9E+04	2.9E+03

TABLE C-9.—Soil Detection Statistics by Watershed and by Analyte (ER Risk Database [LANL 1998]—Inorganics and Radiochemistry)-Continued

WATERSHED	ANALYTE	UNITS	DETECTED	ANALYZED	MINIMUM	MEAN	MAXIMUM	UCL
Water Canyon (Cont.)	Cesium-137	pCi/g	89	129	5.9E-02	5.2E-01	3.3E+00	6.4E-01
	Chromium, Total	mg/kg	571	587	7.6E-01	9.5E+00	4.1E+02	1.1E+01
	Cobalt	mg/kg	415	587	2.8E-01	5.2E+00	1.1E+02	5.9E+00
	Copper	mg/kg	567	603	9.1E-01	7.1E+01	7.7E+03	1.0E+02
	Cyanide, Total	mg/kg	4	216	8.1E-02	5.4E-01	1.6E+00	1.3E+00
	Europium-152	pCi/g	10	103	1.2E-01	2.1E-01	3.5E-01	2.5E-01
	Iron	mg/kg	586	587	9.2E+00	1.0E+04	1.1E+05	1.1E+04
	Lead	mg/kg	617	623	1.6E+00	3.8E+01	1.7E+03	4.6E+01
	Lead-210	pCi/g	11	27	1.8E+00	3.4E+00	8.6E+00	4.8E+00
	Lead-212	pCi/g	40	43	2.1E-01	1.5E+00	2.3E+00	1.6E+00
	Lead-214	pCi/g	43	47	2.8E-01	1.1E+00	2.4E+00	1.2E+00
	Magnesium	mg/kg	548	587	2.3E+02	1.4E+03	4.8E+03	1.5E+03
	Manganese	mg/kg	587	587	3.4E+01	3.3E+02	1.9E+03	3.4E+02
	Mercury	mg/kg	224	596	5.2E-03	5.2E-01	3.5E+01	8.6E-01
	Neodymium-147	pCi/g	1	1	3.9E+01	3.9E+01	3.9E+01	
	Neptunium-237	pCi/g	2	103	1.1E+00	1.3E+00	1.5E+00	1.7E+00
	Nickel	mg/kg	473	587	7.6E-01	1.4E+01	4.5E+02	1.7E+01
	Plutonium-238	pCi/g	18	33	2.0E-03	3.0E-02	1.0E-01	4.9E-02
	Plutonium-239	pCi/g	20	31	9.0E-03	5.6E-02	1.0E-01	7.3E-02
	Potassium	mg/kg	544	587	2.1E+02	1.3E+03	5.4E+03	1.4E+03
	Potassium-40	pCi/g	41	43	9.8E+00	2.3E+01	3.2E+01	2.4E+01
	Protactinium-231	pCi/g	26	64	2.9E-01	3.6E+00	5.0E+00	4.1E+00
	Protactinium-234	pCi/g	6	53	4.1E-01	6.5E+00	2.3E+01	1.4E+01
Protactinium-234M	pCi/g	22	70	9.3E+00	3.1E+02	2.5E+03	5.4E+02	
Radium-224	pCi/g	10	23	2.3E+00	4.0E+00	5.1E+00	4.6E+00	

TABLE C-9.—Soil Detection Statistics by Watershed and by Analyte (ER Risk Database [LANL 1998]—Inorganics and Radiochemistry)-Continued

WATERSHED	ANALYTE	UNITS	DETECTED	ANALYZED	MINIMUM	MEAN	MAXIMUM	UCL
Water Canyon	Radium-226	pCi/g	41	54	7.5E-01	1.8E+00	1.5E+01	2.4E+00
	Radium-228	pCi/g	1	1	2.0E+00	2.0E+00	2.0E+00	
	Selenium	mg/kg	101	595	7.0E-02	5.5E-01	4.6E+00	6.9E-01
	Silver	mg/kg	96	587	9.7E-02	5.5E+00	1.1E+02	8.6E+00
	Sodium	mg/kg	431	587	3.4E+01	2.8E+02	1.4E+04	3.5E+02
	Sodium-22	pCi/g	2	110	3.1E-02	4.5E-02	6.0E-02	7.4E-02
	Strontium-85	pCi/g	1	10	1.1E-01	1.1E-01	1.1E-01	
	Thallium	mg/kg	96	587	1.4E-01	6.4E-01	1.8E+00	7.4E-01
	Thallium-208	pCi/g	35	39	1.2E-01	5.0E-01	1.3E+00	5.8E-01
	Thorium-227	pCi/g	2	17	2.4E+01	2.7E+01	3.1E+01	3.4E+01
	Thorium-228	pCi/g	25	29	1.5E-01	1.7E+00	9.5E+00	2.6E+00
	Thorium-230	pCi/g	64	70	9.4E-02	1.1E+00	5.4E+00	1.3E+00
	Thorium-231	pCi/g	16	46	2.8E-01	4.5E-01	6.3E-01	5.0E-01
	Thorium-232	pCi/g	24	24	2.0E-01	1.1E+00	1.7E+00	1.3E+00
	Thorium-234	pCi/g	64	92	1.1E+00	7.2E+01	1.9E+03	1.4E+02
	Uranium	mg/kg	119	272	9.7E-01	3.3E+00	1.1E+01	3.7E+00
	Uranium-234	pCi/g	84	89	5.8E-01	2.1E+01	1.7E+03	6.0E+01
	Uranium-235	pCi/g	39	121	4.1E-02	6.2E+00	8.7E+01	1.2E+01
	Uranium-238	pCi/g	65	89	6.7E-01	4.4E+01	1.7E+03	9.7E+01
	Vanadium	mg/kg	547	587	8.9E-01	1.8E+01	1.1E+02	1.9E+01
Zinc	mg/kg	587	587	9.3E+00	7.2E+01	1.6E+03	8.3E+01	

Note: Watersheds are defined in ER Project FIMAD map G105700, July 24, 1997.

Note: The analytical data provided in these tables were obtained from the Facility for Information Management, Analysis, and Display (FIMAD) in August, 1998. The data represent analytical results for surface soil samples collected by the ER Project with a begin depth equal to 0 inches and an end depth less than or equal to 12 inches. The data were obtained from ER Project-approved fixed-site analytical laboratories using standard analytical methods (EPA methods for organics and inorganics; LANL-approved methods for radionuclides). Field measurements, non-standard measurements (e.g. x-ray fluorescence), and measurements for non-chemical specific data (e.g. gross radioactivity) were excluded. Quality assurance/quality control data were also excluded. The ER Project may have removed contaminated soil in voluntary corrective actions subsequent to sampling; therefore, some analytical results may represent contaminants that have been removed since the samples were taken.

REFERENCES

- Environmental Surveillance Report Data See individual entries for LANL Environmental Surveillance Reports (ESRs): LANL 1993 (1991 ESR), LANL 1994 (1992 ESR), LANL 1995 (1993 ESR), LANL 1996a (1994 ESR), LANL 1996b (1995 ESR), LANL 1997 (1996 ESR).
- LANL 1993 *Environmental Surveillance at Los Alamos During 1991*. Los Alamos National Laboratory. LA-12572-ENV, UC-902. Los Alamos, New Mexico. August 1993.
- LANL 1994 *Environmental Surveillance at Los Alamos During 1992..* Los Alamos National Laboratory. LA-12764-MS, UC-902. Los Alamos, New Mexico. July 1994.
- LANL 1995 *Environmental Surveillance at Los Alamos During 1993*. Los Alamos National Laboratory. LA-12973-ENV, UC-902. Los Alamos, New Mexico. October 1995.
- LANL 1996a *Environmental Surveillance at Los Alamos during 1994*. Los Alamos National Laboratory, Environmental Assessments and Resource Evaluations Group. LA-13047-ENV. Los Alamos, New Mexico. July 1996.
- LANL 1996b *Environmental Surveillance at Los Alamos During 1995*. Los Alamos National Laboratory. LA-13210-ENV, UC-902. Los Alamos, New Mexico. October 1996.
- LANL 1997 *Environmental Surveillance and Compliance at Los Alamos During 1996*. Los Alamos National Laboratory. LA-13343-ENV. Los Alamos, New Mexico.
- LANL 1998 Environmental Restoration Project data from the ECO_ANAL static data table in the FIMAD Oracle database. February 1998.
- NPDES Data Data on Water Quality, obtained from the LANL Water Quality and Hydrology Group (ESH-18) NPDES Chemical Database. Only 1994–1996 data available currently.

APPENDIX D

HUMAN HEALTH

D.1 PUBLIC HEALTH CONSEQUENCES: PRIMER AND RECENT STUDIES NEAR LANL

In this appendix, supplemental information is presented on the effects on human health of radioactive and chemical exposures. The information is presented in two sections: that addressing our general knowledge and understanding (section D.1.1) and that presenting in more detail the findings of the recent studies of public health in the community of Los Alamos, and New Mexico and U.S. studies (including Native Americans in New Mexico, Hispanic white and nonhispanic white populations throughout the U.S. (section D.1.2). The presentation in section D.1.1 is useful to the reader as a primer on human health effects of exposures to radioactivity or to chemicals. The summaries presented in section D.1.2 are the results of descriptive epidemiology studies. That is, they are analyses of disease incidence rates and causes of death using statistical analytical methodologies.

Exposure to toxic chemicals is regulated by other agencies, and DOE subscribes to and applies those regulations without change to its own activities. The Occupational Safety and Health Administration (OSHA) promulgates and enforces regulations for the protection of workers, and EPA regulates exposures to the public. Chapter 7 provides a detailed review of the regulatory requirements for the operation of LANL.

D.1.1 Primer on Human Health Consequences of Radiological and Chemical Exposures

Table D.1.1–1 summarizes the differences in consequences between exposures to radioactive

materials and exposures to chemicals. More detailed information on the modes of exposure and potential effects of these exposures are given in the sections below.

D.1.1.1 *About Radiation and Radioactivity*

In the simplest sense, radiation is defined as energy propagated through space (NBS 1952). This definition covers a broad range, including visible light, radio and television transmissions, microwaves, and emissions from atomic and nuclear reactions and interactions. The method by which radiation interacts with matter is by transferring its energy to the atoms of the matter. The amount of energy transferred determines the effect that it will have on matter. The broad spectrum of radiation can be subdivided into two groups, ionizing and nonionizing. Ionization occurs when the radiation transfers enough energy to strip one or more electrons from the interacting atom. When ionization takes place in the body, it can cause chemical and physical changes that are of concern to human health. Radiation that does not have enough energy to strip electrons is called “nonionizing” (discussed further in appendix D, section D.2.2.2).

Ionizing radiation is used in a variety of ways, many of which are familiar to us in our everyday lives. The machines used by doctors to diagnose and treat medical patients typically use x-rays, which is one form of ionizing radiation. The process by which a television displays a picture is by ionizing coatings on the inside of the screen with electrons. Most home smoke detectors use a small source of ionizing radiation to detect smoke particles in the room’s air.

TABLE D.1.1-1.—Comparison of Consequences of Radioactivity and Toxic Chemicals

	RADIOACTIVE MATERIALS	TOXIC CHEMICALS
Threshold for effects?	Assume no threshold (stochastic effects).	Yes, and different thresholds for different effects.
Accumulative effects?	Assumed exposures accumulate over a lifetime, with no repair.	Typically, the body repairs itself between exposures; may build sensitive allergic reaction or interact with cells.
Sensory perception?	We do not feel, smell, or otherwise sense ionizing radiation.	Very low concentrations not sensed. Often an annoying odor and irritating effects at low concentrations. Some gases are visible when in high concentrations.
Carcinogenic?	All ionizing radiation is regulated as carcinogenic.	Only some chemicals are confirmed human carcinogens. Some others are suspected, and some are animal (mammal, or closer to human, primate) carcinogens.
Effects-exposure relationship?	Usually treated as linear at low doses, although this is a conservative simplification (BEIR V 1990).	Typically nonlinear and nonadditive. Thresholds exist. For some chemicals, effects can be treated as linear with exposures, but only over small ranges. Synergisms among chemicals are not understood.
Acute effects?	Acute deterministic effects are soon observed, but occur only above a threshold of about 50 rem (less for the eye).	Effects may be immediately observed for levels of exposures above the thresholds.
Entry paths of particulates into the body?	Radionuclides enter through inhalation, ingestion, and wounds. A few are absorbed through the skin.	Same routes, except a greater percentage of chemicals than of radionuclides are absorbed through the skin.
Target organs?	The chemistry of the radionuclide determines its residence time and location in the body.	Same as for radionuclides. Except, the body also metabolizes chemicals, sometimes into more toxic chemicals.
Penetrating?	Alpha and beta radiation do not penetrate skin. In contrast, dense materials are needed to shield against gamma and x-ray radiation.	About 20% of OSHA-regulated chemicals have skin as an import route of entry. Only corrosive chemicals penetrate protective gear rapidly.

Ionizing radiation is generated through many mechanisms. The two most common mechanisms are the electrical acceleration of atomic particles such as electrons, as in x-ray machines, and the emission of energy from nuclear reactions in atoms. This second process is termed “radioactive decay.” Atoms are made up of various combinations of particles called protons, neutrons, and electrons. In most cases, the numbers of neutrons and protons are balanced such that the atom will stay together forever. An atom formed with too many of either the neutrons or protons will attempt to change itself into a more stable form. To do this, the atom will emit an atomic particle, such as an electron, normally called a beta particle, or a “packet” of energy called a photon. This is the process of radioactive decay. The time that it takes for the atom to decay is characterized by a value called the half-life. This is the time it takes for a quantity of radioactive material to decay to one-half its original amount. In general, radioactive materials are identified by their half-lives and the type and energy of their emissions. In some cases, atoms may emit a highly energetic, ionized, helium atom, called an alpha particle. The energy carried away by these emissions is normally capable of creating a large number of ionizations in matter.

Besides ionization, other particles can often be emitted during interactions between radiation and matter, depending upon the type and energy of the interaction. Neutrons, protons, and some other more exotic particles are often emitted during various processes. Nuclear reactors use neutrons to break apart, or fission, particular isotopes of uranium and plutonium in order to release heat and more neutrons to continue the reaction. Large machines, often called “atom smashers,” cause atoms at high energies to collide and break apart, releasing particles in order to study their nuclear structure. However, due to the design and operation of these types of facilities, it would be highly unlikely for these types of radiations to reach the public outside the boundaries of the facility.

When an individual is in the presence of an unshielded radiation source, this is referred to as being exposed. The amount of ionizing radiation that the individual receives during the exposure is referred to as dose. The measurement of radiation dose is called radiation dosimetry, and is done by a variety of methods depending upon the characteristics of the incident radiation. The units of measure for radiation doses are normally rads and rem. (Note that the term millirem [mrem] is also used often. A millirem is one one-thousandth of a rem.) The rad is a measure of the energy deposited in the body by the radiation, regardless of the type of emission. The rem is a measure of the biological effect, by including the effectiveness of the particular type and energy of the incident radiation for causing biological effects. This is due to the fact that some heavier or higher energy radiations, such as alpha particles or neutrons, can deposit their energy into much smaller volumes, and consequently, cause more intense damage through localized, chemical changes.

When an individual is exposed to an unshielded radiation source, this is called external radiation. If radioactive material is incorporated into the body and consequently decays, it is called internal radiation. The external radiation is measured as a value called the deep dose equivalent (DDE). Internal radiation is measured in terms of the committed effective dose equivalent (CEDE). More information about the CEDE is presented in the discussion about the processes by which radioactive material enters the body. The sum of the two contributions (DDE and CEDE) provides the total dose to the individual, called the total effective dose equivalent (TEDE). Often the radiation dose to a selected group or population is of interest, and is referred to as the collective dose equivalent, with the measurement units of person-rem.

D.1.1.2 *About Radiation and the Human Body*

Ionizing radiation affects the body through two basic mechanisms. The ionization of atoms can generate chemical changes in body fluids and cellular material. Also, in some cases the amount of energy transferred can be sufficient to actually knock an atom out of its chemical bonds, again resulting in chemical changes. These chemical changes can lead to alteration or disruption of the normal function of the affected area. At low levels of exposure, such as the levels experienced in occupational or environmental settings, these chemical changes are very small and ineffective. The body has a wide variety of mechanisms that repair the damage induced. However, occasionally, these changes can cause irreparable damage that could ultimately lead to initiation of a cancer, or changes to genetic material that could be passed to the next generation. The probability for the occurrence of health effects of this nature depends upon the type and amount of radiation received, and the sensitivity of the part of the body receiving the dose.

At much higher levels of exposure, at least 10 to 20 times higher than the legal limits for occupational exposures, the body is unable to recover from the large amount of chemical changes occurring during the exposure. At these levels, damage is much more immediate, direct, and observable. Health effects range from reversible changes in the blood to vomiting, loss of hair, temporary or permanent sterility, and other changes leading ultimately to death at exposures above about 100 times the regulatory limits. In these cases, the severity of the health effect is dependent upon the amount and type of radiation received. Exposures to radiation at these levels are quite rare, and, outside of intentional medical procedures for cancer therapy, are always due to accidental circumstances.

For low levels of radiation exposure, the probabilities for induction of various cancers or genetic effects have been extensively studied by both national and international expert groups. The problem is that the potential for health effects at low levels is extremely difficult to determine without extremely large, well-characterized exposed populations. Therefore, only particular groups with fairly high exposures, such as atomic bomb survivors, radiation accident victims, and some groups receiving large medical exposures, can be studied to evaluate the probabilities. Unfortunately, the levels and rates of exposures, and the conditions under which they occurred, are very different from those in which the normal population is exposed to background radiation or to normal operational releases from nuclear operations. Therefore, expert groups must make significant approximations and assumptions in order to apply the study results to the lower levels of exposure. This is done in a manner that attempts to ensure that the resulting risk factors are conservative estimates of the actual probabilities. In other words, it is unlikely that the actual risks are greater than the estimates, while it is fairly likely that the actual risk is smaller than the estimate.

There is another type of study, referred to as an epidemiology study, that attempts to estimate the risk factors in populations with much lower doses than mentioned above. These studies are even more difficult to perform. There are two types of epidemiology studies: descriptive (based on statistical analyses of death and disease incidences) and analytical (case studies and observational analysis within a community or work force). The studies summarized in chapter 4, section 4.6.1.2, and appendix D, section D.1.2, are descriptive. The risk factors for radiation-induced cancer at low levels of exposure are very small, and it is extremely important to account for the many nonradiation related mechanisms for cancer induction, such as smoking, diet, lifestyle, and chemical exposures. These multiple factors also make it

difficult to establish cause-and-effect relationships that could attribute high or low cancer rates to specific initiators. As a consequence, the results of such studies have not been generally accepted within the scientific community and are not currently used as the primary basis for establishing the risk factors.

Risk factors are estimated for a large number of fatal and nonfatal cancers, for hereditary effects, and a few other identified radiation-induced health effects. Table D.1.1.2–1 lists the fatal cancer risk factors used in this SWEIS, which are based upon the recommendations of a recognized authoritative international expert group, the International Commission on Radiological Protection (ICRP). The other, smaller risk factor in the table for nonfatal cancer and hereditary effects may be similarly applied by interested readers.

In keeping with the previous discussion of the difficulties in determining the risk factors used in this document, it is worthwhile to discuss the level of confidence that is associated with those factors. The ICRP, in the recommendation that established the risk factors used here, stated that, “The nominal values of fatal cancer risk, which form the basis of the detriment following radiation exposure, are not to be regarded as precise and immutable. They are, unfortunately, at this time still subject to many

uncertainties and to many assumptions involving factors which may be subject to change. ...It is hoped, and indeed expected, that these uncertainties will diminish in the future as the accumulated experience in exposed populations such as the Japanese survivors increases and as more information develops from a broader variety of human experiences” (ICRP 1991). The Committee on the Biological Effects of Ionizing Radiations (BEIR), which developed the risk factors that the ICRP recommends, also discussed the uncertainty of the factors: “Finally, it must be recognized that derivation of risk estimates for low doses and dose rates through the use of any type of model involves assumptions that remain to be validated. ...Moreover, epidemiologic data cannot rigorously exclude the existence of a threshold in the millisievert (1 millisievert = 100 millirem) dose range. Thus the background radiation cannot be ruled out. At such low doses and dose rates, it must be acknowledged that the lower limit of the range of uncertainty in the risk estimates extends to zero” (BEIR V 1990).

Given these concerns, the reader should recognize that these risk factors are intended to provide a conservative estimate of the potential impacts to be used in the decision-making process, and are not necessarily an accurate representation of actual anticipated fatalities. In other words, one could expect that the stated

TABLE D.1.1.2–1.—Risk Factors for Cancer Induction and Heritable Genetic Effects from Exposure to Ionizing Radiation

EXPOSED POPULATION^a	FATAL CANCER^b	NONFATAL CANCER	HEREDITARY EFFECTS (SEVERE)^d	TOTAL DETRIMENT
Adult Workers	0.0004 ^c	0.00008	0.00008	0.00056
Whole Population	0.0005 ^c	0.0001	0.00013	0.00073

^a The distinction between the worker risk and the general public risk is attributable to the fact that sensitivities vary with age, general health, and other factors that contribute more to the general population than to the worker population.

^b When applied to an individual, units are lifetime probability of excess cancer fatalities per rem of radiation dose. When applied to a population of individuals, units are excess numbers of fatal cancers per person-rem of radiation dose.

^c This is the source of the 4×10^{-4} worker and 5×10^{-4} public risk factors used in this SWEIS.

^d Heritable genetic effects as used here apply to populations, not individuals. For the other columns, the units would change accordingly, in terms of number of effects per unit dose.

Source: ICRP 1991

impacts from an activity or accident form an envelope around the situation, and that actual consequences could be less, but probably would not be worse.

When considering the risks from exposure to ionizing radiation, it is important to remember that we are always being exposed to the radiation in the environment around us. Natural background radiation is the collective term for all of the sources that occur naturally, such as cosmic radiation and naturally occurring radioactive materials, such as potassium, uranium, thorium, radium, and others. These sources contribute an average of 0.3 rem per year to each individual. Manufactured radiation sources contribute another 0.06 rem per year on the average, with the majority coming from medical procedures. Fallout from the atmospheric testing of nuclear weapons currently contributes less than 0.001 rem per year to our doses (NCRP 1987).

D.1.1.3 *About Radioactive Material Within the Body*

Typically, radioactive material that is released into the environment is in the form of very fine particulates, gases, or liquids. That is usually because these forms are the hardest to contain in a facility. This material is easily carried into and spread around the air, soil, and water. As these materials move through the environment, it is possible for them to be taken into the body, through breathing, eating, or drinking. During normal operations of a facility, every effort is made to minimize these releases to levels well below natural background. During accidents, it is possible that higher levels may be released; but, the facilities are designed and operated to control these releases as much as possible.

Radioactive material normally enters the body through one of three mechanisms. When the material is in the air, it is inhaled into the lungs, where a fraction will be trapped, depending upon the size of the particles. When it is

ingested by eating or drinking, or by clearing of the respiratory tract, it passes through the stomach and into the gastrointestinal tract. Under the right conditions, it can also be absorbed through the skin or enter through open wounds.

Once in the body, the fate of the material is determined by its chemical behavior. Some material will be dissolved into bodily fluids and transferred into various organs of the body. Remaining material may either be retained at its point of entry, such as in the lungs, or pass through the body rapidly, as in the gastrointestinal tract. The effect of material in the body is characterized by the type of radiation it delivers and the organs in which it tends to collect. The rate at which the material is removed from the body is represented by a value called effective biological half-life (the time it takes for the activity in the body to be reduced to one-half as a consequence of radioactive decay and biological turnover of the radionuclide).

When radioactive material is in the body, it irradiates the living tissue around it. Some radiation types, like beta and alpha particles, are much more effective at causing changes when inside the body than when outside. This is because these types of radiation cannot effectively penetrate the dead layer of the skin from an external source. As mentioned above, the radiation dose from material inside the body is called the CEDE. Remember that the dose from an external source stops when you walk away or are shielded from it. But you cannot walk away from an internal source. Therefore, the CEDE is designed to determine the risk commitment from the intake. It is the dose that will be received over the next 50 years from the material in the body. Because of the assumptions that doses are cumulative and their effects are not repaired, this means that the lifetime risk from an internal source in rem CEDE can be directly compared to the risk from an external source in rem DDE.

D.1.1.4 *About the Material of Interest at LANL*

LANL has a large involvement in nuclear science and applications. Therefore, there are many types of radioactive material and radiation sources in use. However, many of the uses require only very small amounts of material. Note that all radioactive materials are considered in this SWEIS; but, there are three types that tend to dominate the human health effects and DOE accident scenarios. This is due to either their particular radioactive and biological characteristics, the quantities of material being used, or the potential for dispersion in an accident. These materials are plutonium, uranium, and tritium.

Plutonium is a man-made element that has several applications in weapons, nuclear reactors, and space exploration. There are several types of plutonium atoms, called isotopes, which are distinguished by the different numbers of neutrons in their nucleus. (Note that isotopes of a particular atom all behave the same chemically.) In most cases, the isotopes of plutonium of interest here decay by alpha particle emission with radioactive half-lives ranging from tens to thousands of years. There is nothing unique about plutonium as a health risk compared to other radioactive materials. It is only that once incorporated into the body, it tends to stay for a very long time and deposits a lot of localized energy due to its alpha particles.

Uranium is a naturally occurring radioactive element. The discovery that an atom of uranium could be fissioned with neutrons was the starting point of the Nuclear Age. Uranium-235 is one of several fissile materials that fission with the release of energy.

Various applications require the use of different isotopes of uranium. Because isotopes cannot be chemically separated, processes have been developed to enrich uranium to various isotopic

ratios. Enriched uranium is uranium that is enhanced in the isotope uranium-235 above its natural ratio of 0.72 percent. Highly enriched uranium (HEU) is where the uranium-235 content is 20 percent or greater. Depleted uranium (DU) is where the content of uranium-235 is below its natural value. Obviously, natural uranium is where the material is in its natural isotopic ratios.

Most uranium isotopes of interest here have very long half-lives and are alpha emitters. Their half-lives are much longer than the plutonium isotopes, and as a result uranium is generally of lower radiological concern than plutonium. However, its actual radiological concern varies with its enrichment. As a heavy metal, uranium also can be chemically toxic to the kidneys. Depending upon the enrichment and chemical form, either chemical or radiological considerations will dominate.

Tritium is a radioactive isotope of hydrogen. It is generated at low levels in the environment by interactions of cosmic radiation with the upper atmosphere, but for practical applications it is normally produced in a nuclear reactor. Tritium has a half-life of around 12 years and decays by emitting a low energy beta particle. Because tritium is an isotope of hydrogen, it can be incorporated into the water molecule, forming tritiated water. In the environment, tritium is most often found either in its elementary form as a gas, or as water. Tritiated water is a significant concern to the human body because the body is composed mostly of water. This actually is a mixed blessing. Tritiated water will easily and rapidly enter the body and irradiate it rather uniformly; however, it also is removed from the body rather quickly, being easily displaced with regular water and with a biological half-life of about 12 days under normal conditions.

D.1.1.5 *How DOE Regulates Radiation and Radioactive Material*

Radiation doses to workers and the public and the release of radioactive materials are regulated by DOE for its contractor facilities. Under the conditions of the *Atomic Energy Act* (as amended by the *Price-Anderson Amendments Act of 1988*), DOE is authorized to establish federal rules controlling radiological activities at DOE sites. The act also authorizes DOE to impose civil and criminal penalties for violations of these requirements. Some activities are also regulated through a DOE Directives System that uses contractual means to regulate the contractor activities.

Occupational radiation protection is regulated by the *Occupational Radiation Protection Rule*, Title 10 of the Code of Federal Regulations, Part 835 (10 CFR 835). Environmental radiation protection is currently regulated contractually with DOE Order 5400.5, which is in the process of being converted to a rule. There is a process by which these regulations are developed. The EPA, working with other agencies such as DOE and the NRC, develops a federal guidance document that is signed by the President (52 *Federal Register* [FR] 2822–2834). This document is based upon the recommendations of the National Council on Radiation Protection and Measurements (NCRP), and considers recommendations of international expert groups such as the ICRP. This federal guidance then becomes the basis for all federal regulations for radiation protection, including DOE's and also U.S. Nuclear Regulatory Commission (NRC) rules. This process ensures a common, scientifically based approach to all radiation protection in the U.S.

D.1.1.6 *About Chemicals and Human Health*

The characteristics and consequences of exposures to chemicals are quite different from those of exposure to ionizing radiation. Table D.1.1–1 summarizes the differences.

For noncarcinogens, there are threshold concentrations that must be exceeded for observable adverse effects to happen; whereas, for ionizing radiation it is assumed that the integrated (accumulated) exposure determines the likelihood of observable effects.

The threshold values for effects from toxic chemicals vary somewhat among individuals, but values can be determined that represent most of the more vulnerable people among the general population. The several different effects from a chemical each have different thresholds. For instance, there may be different concentrations that produce odor, irritation, effects that last only a short time, permanent effects, and death. Older and ill people, and those with a particular sensitivity such as respiratory problems, are more vulnerable and will have lower thresholds for effects.

Using human inhalation of chlorine in illustration, 0.2 to 0.4 parts per million (parts of chlorine per million parts of air) is the odor threshold; 1 to 3 parts per million for periods less than an hour produce burning eyes, scratchy or irritated throat, and headache; 15 parts per million is the lowest concentration observed to cause respiratory distress; no deaths were observed in any animals exposed to 50 parts per million for 30 minutes; and 210 parts per million has been estimated to be the 30-minute LC50 for humans, although 50 parts per million might cause death in some vulnerable individuals. (The 30-minute LC50 is defined as the concentration that produces 50 percent fatalities among individuals exposed for 30 minutes.)

The ability to resist a potential effect and to recover from that effect clearly depends upon a person's health and age. For the population of workers, presumed to have few individuals who are especially vulnerable, regulatory agencies set permissible exposure limits and average concentrations for the 8-hour and 10-hour work day. Lower values than these would be appropriate to public exposures; whereas, higher values are deemed acceptable for military personnel under military exigencies.

Again using inhalation of chlorine gas in illustration, the OSHA permissible exposure limit is a time-weighted average (TWA) over the 8-hour work day of 0.5 parts per million¹. There also is an OSHA short-term exposure limit of a 1-part-per-million 15-minute TWA that should not be exceeded at any time during the work day. The immediately dangerous to life and health (IDLH) value is 30 parts per million; this is the concentration from which a worker could escape within 30 minutes without a respirator and without escape-impairing or irreversible effects.

This SWEIS analysis uses the TWA as a convenient measure for screening the chemical inventory at LANL, and then uses Emergency Response Planning Guidelines (ERPGs) or their surrogate Temporary Emergency Exposure Limits (TEELs) for bounding the consequences to persons exposed to a release to the atmosphere. ERPGs are provided by the American Industrial Hygiene Association (AIHA) for planning for emergencies, rather than for determining consequences. ERPG-1, ERPG-2, and ERPG-3 are defined and described in detail in appendix G, Accident Analysis. They are intended to provide protection for most members of the public, and so their exposure time (up to one hour) and their concentrations are directly related to effects (no safety factor of ten was applied).

¹. The definition of the TWA is the sum of all the instantaneous air concentrations over the 8 hours, averaged by dividing by the 8 hours.

Again using chlorine in illustration, the ERPG-2 is 3 parts per million, the concentration at which nearly all individuals could be exposed without irreversible or other serious health effects or impairment of ability to take protective actions. The ERPG-3 is 20 parts per million, below which nearly all individuals could be exposed without life-threatening effects.

Only for some chemicals and only for a limited extent, effects are directly related to the product of the concentration and length of exposure ("Haber's Law"). Chlorine is not such a chemical. When attempting to apply an existing guideline to a different exposure period than for which the guideline applies, toxicologists must be consulted, and they will consider actual effects data.

D.1.1.7 *How Toxic Chemicals Affect the Body*

Some toxic chemicals can have direct effects upon the eyes and the skin through contact and can enter the body by absorption through the skin. These are considered in the derivation of guides and limits for airborne concentration. Toxic chemicals also can enter the body via ingestion (eating and drinking). All the LANL accidents considered in the SWEIS that pose significant risk to the public produce their exposure through airborne releases, and so airborne concentrations guides and limits are used in the screening and consequence analyses.

After intake, the chemical may follow primarily one or more routes within the body, involving the respiratory system and digestive system, the blood circulatory system, and the urinary tract. The route and residence time before excretion is strongly determined by the chemical's solubility, and if particulate, by its particle size. The chemical may be metabolized, usually in the liver, into other chemicals that are either more or less toxic. For carcinogens, the principal target organs (i.e., where the effects

primarily occur) are the respiratory tract, urinary bladder, and to a lesser extent the bone marrow, gastrointestinal tract, and liver.

D.1.1.8 About Chemical Carcinogens

Some chemicals are regulated as carcinogens because they or their metabolites may cause cancer. There are limited data on chemical carcinogens for humans, and there are problems with applying the results of animal studies to humans. Therefore, these chemicals are classified as known human carcinogens, potential or suspected carcinogens, and chemicals that cause cancer in animals. Exposure to chemical carcinogens is treated in the same manner as cumulative exposure to ionizing radiation; that is, exposures are assumed to be additive in producing cancer.

Some chemicals are carcinogenic at concentrations that do not produce observable effects from acute (short-term) exposures. For these, the airborne exposure limits and guidelines are based on their carcinogenicity. Some chemicals may produce an irreversible change to cells (tumor initiation), which then may be submitted to chemicals that are promoters of cancer. Such promoters must be given repeatedly to be effective. For this reason, chemical carcinogens are regarded as additive to one another, and individual chemicals are regulated at 1/100 of the exposure level regarded as hazardous, perhaps to account for the conservative possibility of having 100 such chemicals in one's environment.

The carcinogenic effects of certain chemicals are similar to those of ionizing radiation and have been noted in virtually every organ, depending on the chemical, the species, and conditions of exposure. The cancers induced by chemicals and by ionizing radiation cannot be distinguished from cancers induced by other causes. Therefore, the effects of chemicals and ionizing radiation are inferred only on a

statistical basis, and must be inferred from exposures at higher doses and dose rates. The choice of model has a large influence on the estimated excess cancer risk. The extrapolation is made by assuming an uncertain and controversial no-threshold, linear mathematical relationship between dose and resultant effects. This model is usually thought likely to overestimate the risk at low doses, and so is often said to estimate the "upper limit" of risk (NCRP 1989).

Chemicals vary widely in their capacity to induce cancer. There are even fewer data on the carcinogenic effects for chemicals than for radiation. With most chemicals, assessment of risks for humans must be based on extrapolation from laboratory animals or other experimental systems. Hence, the risk assessment for chemicals has even more uncertainty than risk assessment for ionizing radiation (NCRP 1989). Ultimately, the desired certainty in risk assessment at low-level exposures to chemicals and radiation will require better understanding of their effects at all stages of carcinogenesis.

The EPA, in setting standards for compliance with the *Clean Air Act*, is required by judicial decision and the *Clean Air Act* to determine a "safe" level with an "ample margin of safety to protect public health" without consideration as to cost or technology feasibility (Bork 1987). After that level is determined, costs and feasibility can be considered in setting the standard. Although this decision applied specifically to vinyl chloride and the *Clean Air Act*, it aids in understanding the EPA challenge faced in determining what is "safe," "adequate," or "acceptable" when setting standards for protection of workers, public, and environment. In the attempt to provide an objective context for evaluating the risks posed by LANL operations, the SWEIS authors have searched for authoritative statement on acceptable risk levels. A few such statements and inferences can be found in ICRP, NCRP, EPA, and OSHA documents.

EPA regulations provide goals for environmental remediation (cleanup). The EPA goals “for acceptable exposure levels to known or suspected carcinogens are generally concentration levels that represent an excess upper bound lifetime cancer risk between 10^{-4} and 10^{-6} . The 10^{-6} risk level shall be used as the point of departure for determining remediation goals” when existing and relevant requirements are not available or sufficiently protective because there are multiple contaminants or pathways. When the combined risk from multiple contaminants exceed 10^{-4} , then factors such as detection limits and uncertainties may be considered in determining the cleanup level to be attained (40 CFR 300.430). Note that this is the lifetime risk to an undetermined public population group.

OSHA (OSHA 1997) expressed that its proposed worker permissible exposure limit for methylene chloride of 25 parts per million (average for 8 hours per day) would entail an employment lifetime risk of 3.62×10^{-3} , and that this was “clearly well above any plausible upper boundary of the significant risk range defined by the Supreme Court and used by OSHA in its prior rulemaking.” OSHA noted that typical lifetime occupational risk for all manufacturing industries is 1.98×10^{-3} , and that the risk in occupations of relatively low risk, like retail trade, is 8.2×10^{-4} . Note that worker risk is generally accepted at a higher level than public dose because it is an accepted risk of employment. This is compatible with the EPA upper bound lifetime public cancer risk of between 10^{-4} and 10^{-6} .

D.1.1.9 Radionuclides and Chemicals of Interest at LANL

Radionuclides of interest at LANL are discussed with their respective emission facilities in appendix B, section B.1. Chemicals of interest are presented in appendix B, section B.2. LANL has used, uses, and will use a wide

variety of chemicals because of its research mission. LANL has a chemical database that tracks the quantity and location of chemicals on site. About 51 of the chemicals tracked in the database are carcinogenic. A large number of the chemicals tracked in the database are toxic; that is, they are able to produce harm to humans. The analysis of the consequences to the public from chemical emissions under normal operations of LANL is provided in chapter 5, sections 5.2.4 and 5.2.6. Methodology is provided in section 5.1.4 and 5.1.6. Those of risk to the public, should they be accidentally released to the atmosphere, were determined by screening the entire database. Details on the accidental release screening and its results are presented in appendix G, Accident Analysis.

D.1.2 Supplemental Information on Public Health: U.S., New Mexico, and the Local LANL Community

The information presented below is supplemental to the information presented in chapter 4, section 4.6. It is presented to provide the context of the human health analysis provided in chapter 5, which estimates potential consequence to public health.

The population of Los Alamos County has grown primarily by immigration. The average annual fertility rate has remained at approximately 48/1,000 women across all races (DOC 1990 and Athas and Key 1993), which would produce annual growth of only 2.4 percent if there were no deaths. However, the growth rate has been approximately 25 percent between 1950 and 1960, more than 16 percent between 1960 and 1970 as well as between 1970 and 1980, and approximately 3 percent between 1980 and 1990.

Several studies have been conducted in the community due to concerns expressed within the community concerning the rates of some cancers. While these are summarized in section

4.6 of the SWEIS, additional information is presented here in order to meet the request of many during the scoping meetings for presentation of these results in the SWEIS.

These studies are largely descriptive; that is, they use statistical analyses to identify patterns of disease or death in a community. The thyroid cancer study (Athas 1996) reported below is a mixture of descriptive and analytical approaches (based on case studies and observational analyses). All epidemiological studies are subject to limitations in attempting to determine cause and effect relationships. Some of these limitations are:

- Small population sizes in the community to be studied
- Relatively few total numbers of cases of the specific disease or cancer to be studied
- High mobility in the population to be studied (if a large portion of the community has been in the community for shorter periods of time than that necessary to detect chronic disease, results are inconclusive)
- Disease etiology—one may have received the causative exposure decades before its diagnosis; households in the U.S. move on average every 3 years; in Los Alamos County in 1980, 45 percent of residents had been in the same home for 5 years; earlier census data showed lesser periods of time in the same residence
- Comparability—for instance, the makeup of Los Alamos County is quite dissimilar from its surrounding counties in ethnic distribution and in socioeconomic and occupational conditions
- Natural variability in disease incidence within the human population from any and all sources
- Increased technology efficiency used in disease detection, therefore, causing apparent increases in rates of incidence of the better-detected disease
- More than one causal agent suspected or known to cause the disease being studied,

including lifestyle choices such as smoking and dietary patterns

- Disease cause from multiple sources in the same community
- Methodology limitations such as multiple comparison across differing time periods, across studies made for different purposes, consideration of all combinations across the study time frame, etc.

D.1.2.1 Public Health: United States

Heart disease remains the leading cause of death in the U.S. (Table D.1.2.1–1). There has been a significant decrease in mortality in the U.S. attributable to heart disease and cerebrovascular disease over the last 20 years. Cancer remains the second leading cause of death.

Table D.1.2.1–2 identifies the lifetime risk of dying from cancer for men and women by cancer type. Over all cancer types, the lifetime risk of dying from cancer is approximately 24 percent for men and 21 percent for women.

TABLE D.1.2.1–1.—Leading Causes of Death in U.S.: Percent of All Causes of Death (1973 Versus 1993)

CAUSE OF DEATH	PERCENT OF ALL CAUSES (1973)	PERCENT OF ALL CAUSES (1993)
Heart Disease	38.4	32.8
Cerebrovascular	10.9	6.6
Cancer	17.1	23.4
Pneumonia and Influenza	3.2	3.7
Chronic Lung Disease	1.5	1.2
Accidents	5.9	4.0
All Other Causes	22.5	28.4

Source: Ries et al. 1996

TABLE D.1.2.1–2.—Lifetime Risk (Expressed as Percent) of Dying from Cancer: SEER^a Areas (1973 Through 1993), All Races

TYPE OF CANCER	MEN	WOMEN
All Types	23.77	20.66
Oral and Pharynx	0.45	0.24
Esophagus	0.65	0.23
Stomach	0.81	0.53
Colon and Rectum	2.54	2.54
Liver and Bile Duct	0.52	0.33
Pancreas	1.11	1.21
Larynx	0.25	0.07
Lung and Bronchus	7.11	4.35
Melanomas of Skin	0.31	0.20
Breast	0.03	3.54
Cervix Uteri	—	0.27
Corpus and Uterus	—	0.53
Ovary	—	1.12
Prostate	3.62	—
Testis	0.02	—
Urinary Bladder	0.69	0.34
Kidney and Renal Pelvis	0.49	0.33
Brain and Other Nervous	0.51	0.41
Thyroid	0.04	0.07
Hodgkin's Disease	0.06	0.05
Non-Hodgkin's Lymphoma	0.90	0.85
Multiple Myeloma	0.47	0.43
Leukemias	0.93	0.74

^a SEER is the NIH/NCI Surveillance, Epidemiology, and End Results Program.

Source: Ries et al. 1996

Cancer incidence and mortality trends have changed over the last 20 years (Table D.1.2.1–3). Melanoma of the skin, for example, has increased in both incidence and mortality rate, as has brain and other nervous system cancers. Leukemia incidence and mortality rates have decreased.

D.1.2.2 Comparison of Cancer Mortalities Between the U.S. and New Mexico

A comparison of cancer mortality rates between the U.S. as a whole and New Mexico is given in Table D.1.2.2–1. These comparisons were made for 1989 through 1993 based on the National Institute of Health/National Cancer Institute (NIH/NCI) Surveillance, Epidemiology, and End Results (SEER) Program (Ries et al. 1996). For most cancers, differences were insignificant.

However, New Mexico had significantly higher mortality from thyroid cancer. (The reader is referred also to Athas 1996 for the local Los

Alamos County study of thyroid cancer presented below.) New Mexico deaths due to thyroid cancers ranked 4th among the states. Thyroid cancers are associated with some types of radiological processes and research applications, principally those that could result in emitted radio-iodine. LANL has historically not used more than research amounts of radio-iodine. Radio-iodine emissions from LANL have been measured and have continually been very low (chapter 4, section 4.4 and the tables of emissions estimated for key LANL facilities, in chapter 3, section 3.6 discuss this further).

New Mexico had statistically lower rates of cancer mortalities for several cancers (Table D.1.2.2–1) relevant to the Los Alamos cancer studies, specifically, brain and other nervous system cancers and breast cancer.

TABLE D.1.2.1–3.—Trends in Cancer Incidence and Mortality for Selected Cancers (1973 Through 1993), All Races, Both Sexes

DECREASING INCIDENCE; DECREASING MORTALITY	INCREASING INCIDENCE; DECREASING MORTALITY	INCREASING INCIDENCE; INCREASING MORTALITY
Oral Cavity and Pharynx	Ovary	Total Cancers
Stomach	Testis	Esophagus
Colon and Rectum	Urinary Bladder	Liver and Bile Duct
Pancreas	Thyroid	Lung and Bronchus
Larynx		Melanoma of Skin
Cervix Uteri		Breast
Corpus and Uterus		Prostate
Hodgkin’s Disease		Kidney and Renal Pelvis
Leukemia		Brain and Other Nervous
		Non-Hodgkin’s Lymphoma
		Multiple Myeloma

Source: Ries et al. 1996

TABLE D.1.2.2-1.—Comparison of Cancer Mortality Rates for the United States and New Mexico (1989 Through 1993), All Races, Both Sexes (Rate per 100,000 Population, Age Adjusted to 1970 U.S. Standard Population)

TYPE OF CANCER	U.S. RATE	NEW MEXICO RATE	RANKING (AMONG STATES)	COMPARISON U.S. VS. NEW MEXICO
Breast	26.8	23.4	49 th	NM < U.S.
Colon and Rectum	18.4	14.2	50 th	NM < U.S.
Esophagus	3.5	2.4	49 th	NM < U.S.
Hodgkin's Disease	0.6	0.6	25 th	NSD
Larynx	1.4	1.2	34 th	NSD
Leukemia	6.4	6.1	40 th	NSD
Liver and Bile Duct	3.0	3.2	15 th	NSD
Lung and Bronchus	49.9	35.0	49 th	NM < U.S.
Melanomas of Skin	2.2	2.1	49 th	NSD
Non-Hodgkin's Lymphoma	6.4	5.6	46 th	NSD
Brain and Nervous	4.2	3.5	48 th	NM < U.S.
Stomach	4.6	5.0	12 th	NSD
Testis	0.3	0.2	43 rd	NM < U.S.
Urinary Bladder	3.3	2.7	47 th	NM < U.S.
Oral/Pharynx	2.9	2.6	32 nd	NSD
Pancreas	8.4	8.1	40 th	NSD
Thyroid	0.3	0.4	4 th	NM > U.S.
Prostate	26.4	23.2	49 th	NM < U.S.
Ovary	7.8	6.7	47 th	NSD
Kidney and Renal Pelvis	3.5	3.4	36 th	NSD
Multiple Myeloma	3.0	3.0	30 th	NSD
Corpus and Uterus	3.4	3.0	43 rd	NSD
Cervix Uteri	2.9	2.7	33 rd	NSD

Sources: SEER Database and Ries et al. 1996

NSD = No significant difference

D.1.2.3 *Cancer Incidence and Mortality Among Ethnic Groups Relevant to the LANL Area*

While the Native American population within Los Alamos County remains less than 3 percent (DOC 1990), the populations down gradient (with respect to air emissions and water flow) in the adjacent Santa Fe County Area are dominantly Native American (San Ildefonso Pueblo).

Table D.1.2.3–1 summarizes the findings regarding the top five cancers (both incidence and mortality) among nonhispanic whites (U.S.), Hispanic whites (U.S.), and Native Americans (New Mexico). The Native American cancer incidence and cancer mortality rates are lower than either of the other examined populations for both men and women. This is the case for all cancer types, not just the top five cancers with respect to incidence and mortality rate.

Among men, lung and prostate cancer dominate incidence and mortality. Among women, breast and lung cancer dominate cancer incidence and mortality. A fairly rare cancer, gall bladder, is the leading cause of cancer mortality among New Mexican Native American women. However, because there were so few cases, and the uncertainty level thus associated with the observation is so high, it is inappropriate to draw conclusions even regarding gall bladder cancer incidence in this population of women.

D.1.2.4 *Supplemental Information on Recent Studies of Los Alamos County Cancer*

Objectives

The primary objective of the study was to review Los Alamos County incidence rates for brain and nervous system cancer and other

major cancers during the 21-year time period 1970 to 1990 (Athas and Key 1993). Secondary objectives were to review mortality rate data for select cancers of concern and to review Los Alamos County mortality data relating to benign brain and nervous system tumors.

Specific aims developed for incidence study were as follows:

- To calculate age-adjusted cancer incidence rates for Los Alamos County and a New Mexico state reference population using data of the New Mexico Tumor Registry (NMTR)
- To compare Los Alamos County cancer incidence rates to (1) incidence rates calculated for a New Mexico state reference population, and (2) national rates obtained from the SEER Program of the National Cancer Institute
- To determine if any of the Los Alamos County cancer incidence rates were elevated in comparison to rates observed in the reference population

The study protocol specified that statistical tests would be used to determine whether any of the Los Alamos County rates were elevated in comparison to the reference populations. Early in the course of the study, however, it became apparent that the small number of cases for virtually all of the Los Alamos County cancers reviewed would make the finding of statistical significance unlikely for small to modest elevations in a rate. Consequently, the analysis of the Los Alamos County incidence data was expanded to include not only statistical considerations but other types of information such as temporal patterns of cancer occurrence, prevalence of established risk factors, case characteristics, and tumor cell types. Cancers of concern were: oral cavity and pharynx, digestive system, respiratory system, melanoma of the skin, female breast, female genital system, urinary system, male genital system, lymphoreticular system, childhood cancers

TABLE D.1.2.3-1.—The Five Most Frequently Diagnosed Cancer and the Five Most Common Types of Cancer Death (1988 Through 1992) Among White Non-Hispanics (all U.S.), White Hispanics (all U.S.), Native Americans (New Mexico)

POPULATION GROUP	CANCER INCIDENCE ^a			CANCER MORTALITY ^a		
	MEN	WOMEN		MEN	WOMEN	
White, Non-Hispanic	CANCER TYPE (RATES/100,000 POPULATION, AGE ADJUSTED TO 1970 U.S. STANDARD)					
	Prostate (137.9)	Breast (115.7)		Lung (74.2)	Lung (32.9)	
	Lung (79.0)	Lung (43.7)		Prostate (24.4)	Breast (27.7)	
	Colon/Rectum (57.6)	Colon/Rectum (39.2)		Colon/Rectum (23.4)	Colon/Rectum (15.6)	
	Bladder (33.1)	Corpus Uteri (23.0)		Pancreas (9.8)	Ovary (8.2)	
	Non-Hodgkin's Lymphoma (19.1)	Ovary (16.2)		Leukemia (8.6)	Pancreas (7.0)	
	Prostate (92.8)	Breast (73.5)		Lung (33.6)	Breast (15.7)	
	Lung (44.0)	Colon/Rectum (25.9)		Prostate (15.9)	Lung (11.2)	
	Colon/Rectum (40.2)	Lung (20.4)		Colon/Rectum (13.4)	Colon/Rectum (8.6)	
	Bladder (16.7)	Cervix (17.1)		Stomach (8.8)	Pancreas (5.4)	
Native American, NM	Stomach (16.2)	Corpus Uteri (14.5)		Pancreas (7.4)	Ovary (5.1)	
	Prostate (52.5)	Breast (31.6)		Prostate (16.2)	Gallbladder (8.9) ^b	
	Colon/Rectum (18.6)	Ovary (17.5)		Stomach (11.2) ^b	Breast (8.7) ^b	
	Kidney (15.6)	Colon/Rectum (15.3)		Liver (11.2) ^b	Cervix (8.0) ^b	
	Lung (14.4)	Gallbladder (13.2)		Lung (10.4) ^b	Pancreas (7.4) ^b	
	Liver (13.1) ^b	Corpus Uteri (10.7)		Colon/rectum (8.5) ^b	Ovary (7.3) ^b	

^a NIH/NCI SEER Program statistics from several regions around the U.S.

^b Statistics calculated with extremely high uncertainty because they are based on fewer than 25 cases. Other rates (not footnoted) were calculated from larger total numbers of cases and, therefore, have less uncertainty associated with them.

Source: Miller et al. 1996

(ages 0 to 19 years) thyroid, and brain and nervous system cancers.

Following a review of tabulated incidence rate data for 23 major cancers, nine were selected for additional review and evaluation: liver and intrahepatic bile duct cancer, non-Hodgkin's lymphoma, leukemia, melanoma of skin, ovarian cancer, breast cancer, childhood cancers, thyroid cancer, and brain and nervous system cancer. The majority of these cancers were chosen on the basis of incidence rates, which were higher in Los Alamos County in comparison to the reference populations. Childhood cancer was chosen for further review based on mortality rate data showing an apparent excess of childhood cancer deaths in Los Alamos County. Leukemia and liver cancer were chosen as cancers of concern specifically to examine tumor cell types. Cancers not chosen for further review included major sites in the respiratory, digestive, and urinary systems.

Incidence Data: Data Sources

Information regarding newly diagnosed cancers among Los Alamos County residents and New Mexico non-Hispanic Whites was compiled from records collected since 1969 by the NMTR at the University of New Mexico Cancer Center. Cancer is a reportable disease in New Mexico by regulation of the New Mexico Department of Health (NMDOH). Since the late 1960's, NMTR has been the repository of the confidential medical record abstracts and computerized masterfile for cancer in New Mexico. NMTR has been a part of the SEER Program since that program began in 1973.

Cancer Incidence Findings (1970 to 1990)

All Cancers. Figure D.1.2.4-1 shows that the Los Alamos County incidence rates for "all cancers" fluctuated considerably; but the rates generally were comparable to or lower than rates observed in the state and national reference populations.

Liver and Intra-Hepatic Duct Cancer. Seven cases of primary liver and intra-hepatic bile duct cancer occurred in Los Alamos County. Four of the seven cases (57 percent) were diagnosed between 1981 and 1982. Los Alamos County incidence rates were highly variable as a result of the small number of cases and the clustered temporal distribution of cases. No cases were reported up until the early 1980's, at which time the four cases diagnosed in 1981 to 1982 caused a marked elevation in the Los Alamos County rates in comparison to the state and national reference rates (Figure D.1.2.4-2). Los Alamos County rates subsequently diminished to a level consistent with the reference rates.

Non-Hodgkin's Lymphoma. Los Alamos County consistently experienced a small to modest elevation in incidence compared to the reference populations (Figure D.1.2.4-3). The magnitude of the elevated Los Alamos County incidence varied widely up to a two-fold higher than expected level. None of the Los Alamos County lower confidence limits excluded the reference rates. Incidence in the Los Alamos County non-Hispanic White population was consistently higher than that observed in the total county population. All Los Alamos County rates were based on 14 or fewer cases. For the most recent five-year time period (1986 to 1990), the rate for non-Hispanic Whites in Los Alamos County was 57 percent greater than the state reference rate.

Leukemia. The incidence of leukemia in Los Alamos County generally was the same or lower than that observed in the reference populations (Figure D.1.2.4-4). Wide fluctuations in the Los Alamos County rates occurred as a result of low case numbers. All Los Alamos County rates were based on nine or fewer cases. For the most recent 5-year time period (1986 to 1990), the Los Alamos County rate equalled the state reference rate.

Melanoma. The incidence of melanoma consistently was around 50 percent higher in New Mexico non-Hispanic Whites compared

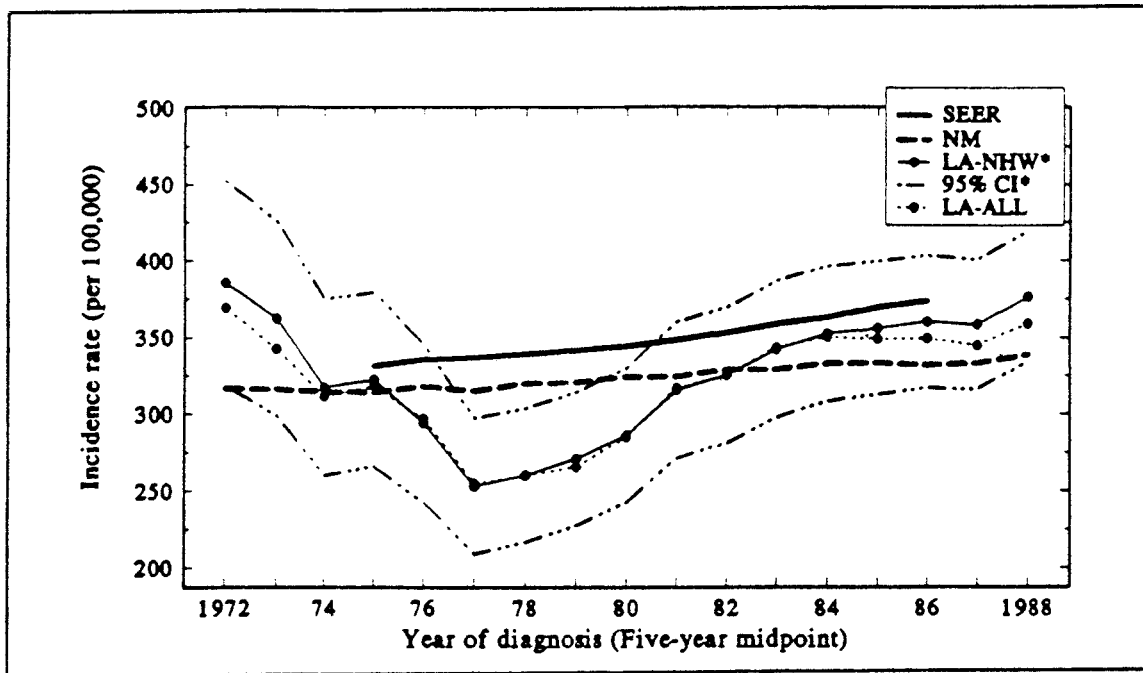

SOURCE: Athas and Key 1993

FIGURE D.1.2.4-1.—5-Year Average Annual Incidence of All Cancer Sites, Los Alamos County, New Mexico NHW, SEER Whites, 1970 to 1990.

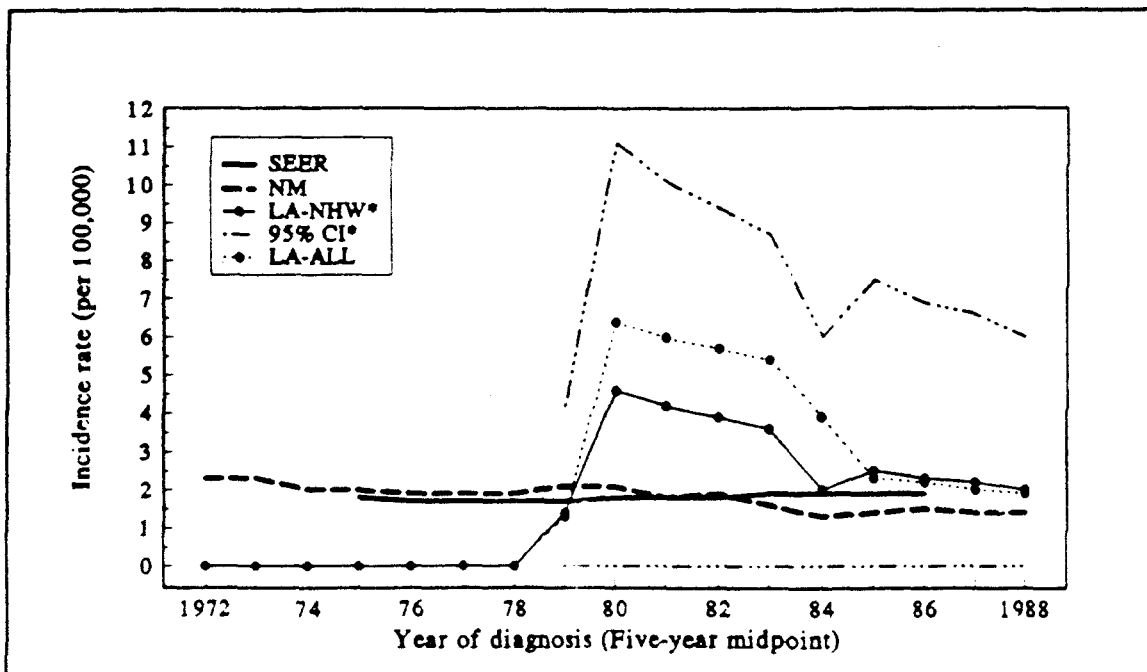

FIGURE D.1.2.4-2.—5-Year Average Annual Incidence of Liver and Intra-Hepatic Bile Duct Cancer, Los Alamos County, New Mexico NHW, SEER Whites, 1970 to 1990.

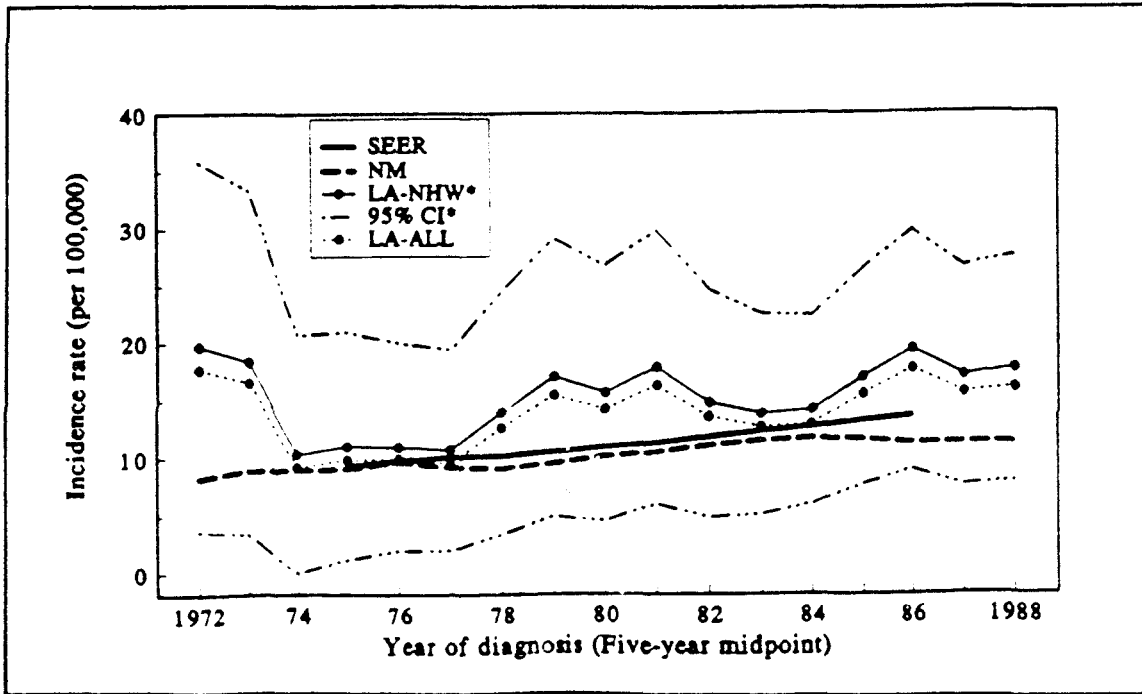

FIGURE D.1.2.4-3.—5-Year Average Annual Incidence of Non-Hodgkin's Lymphoma, Los Alamos County, New Mexico NHW, SEER Whites, 1970 to 1990.

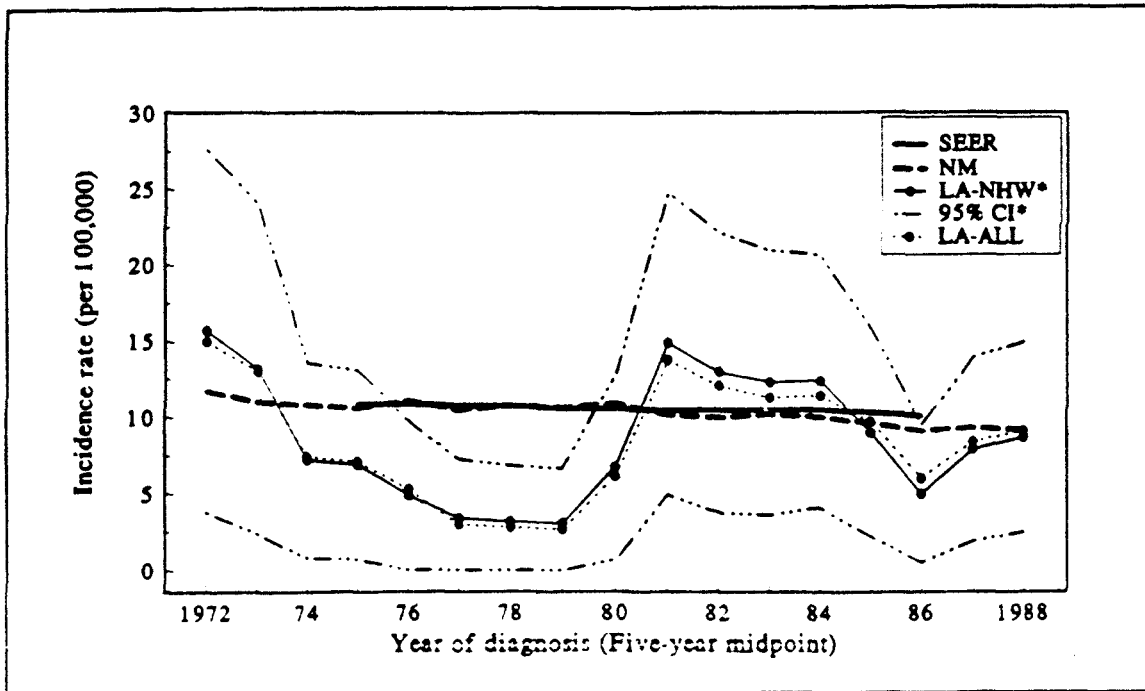

FIGURE D.1.2.4-4.—5-Year Average Annual Incidence of Leukemia, Los Alamos County, New Mexico NHW, SEER Whites, 1970 to 1990.

with SEER Whites. Melanoma incidence steadily increased in both reference populations. Incidence rates in Los Alamos County were higher than the state reference rates over most of the 21-year study time period (Figure D.1.2.4-5). Early time periods were characterized by a small elevation in the Los Alamos County incidence; whereas, a more pronounced excess of melanoma in Los Alamos County began to appear in the mid 1980's. Beginning with the 1982 to 1986 period, and for all subsequent periods, the lower confidence limit of the Los Alamos County rate excluded the state reference rates. During these later periods, the incidence of melanoma in Los Alamos County increased roughly two-fold over that observed statewide.

Ovarian. Los Alamos County rates steadily rose by three-fold during 1970 to 1990, while both the state and national reference rates remained essentially constant (Figure D.1.2.4-6). Initially lower than the reference rates, Los Alamos County incidence climbed to a statistically significant three-fold

excess level during the 1982 to 1986 period. Half of all the Los Alamos County cases (15 out of 30) were diagnosed during these 5 years. Los Alamos County ovarian cancer incidence was two-fold higher than that observed in the state during the most recent 5-year period (1986 to 1990).

Breast. Breast cancer incidence in Los Alamos County women varied little over time; whereas, both reference populations displayed increasing incidence over time (Figure D.1.2.4-7). Los Alamos County incidence rates were 10 percent to 50 percent higher than the state and national reference rates over the entire study period. The lower confidence limits for the Los Alamos County rates consistently were near the reference rates, but excluded the reference rates in only several instances.

Childhood Cancers. Los Alamos County childhood cancer rates fluctuated around the more stable state and national reference population rates (Figure D.1.2.4-8). Following an initial two-fold elevation during the earliest

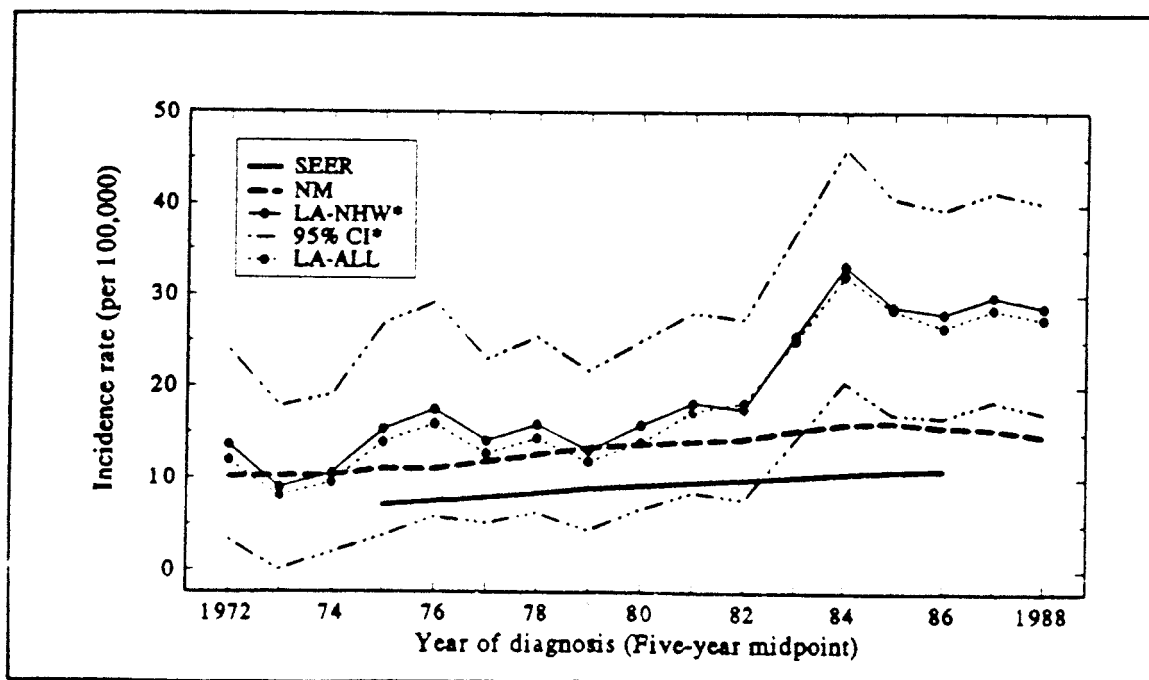

FIGURE D.1.2.4-5.—5-Year Average Annual Incidence of Melanoma of Skin, Los Alamos County, New Mexico NHW, SEER Whites, 1970 to 1990.

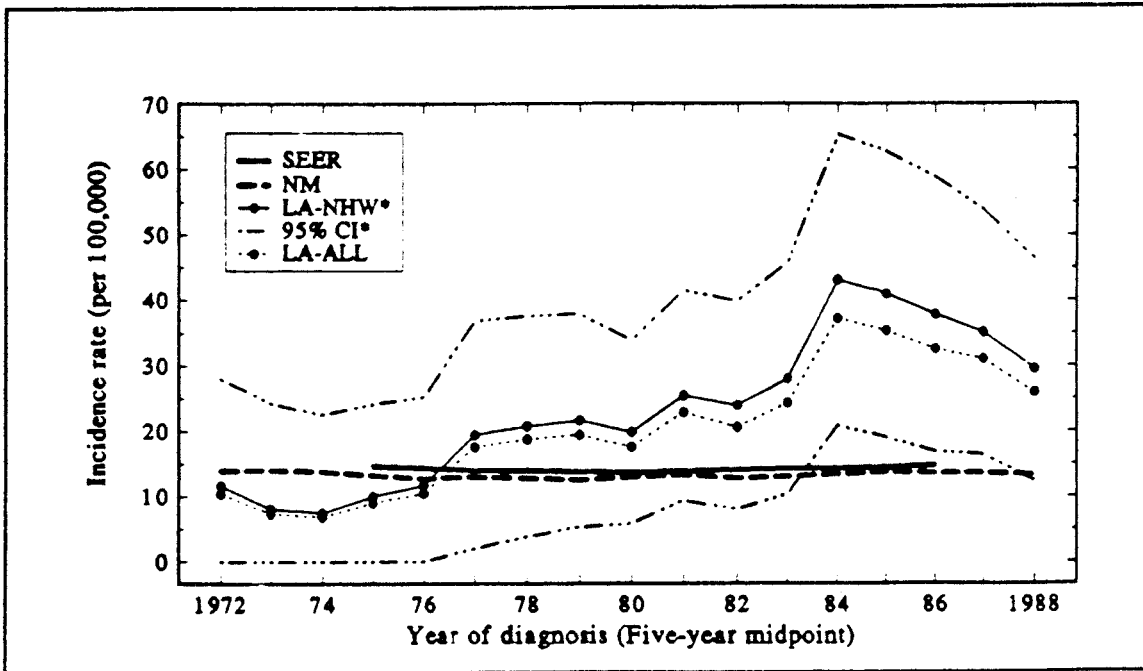

FIGURE D.1.2.4-6.—5-Year Average Annual Incidence of Ovarian Cancer, Los Alamos County, New Mexico NHW, SEER Whites, 1970 to 1990.

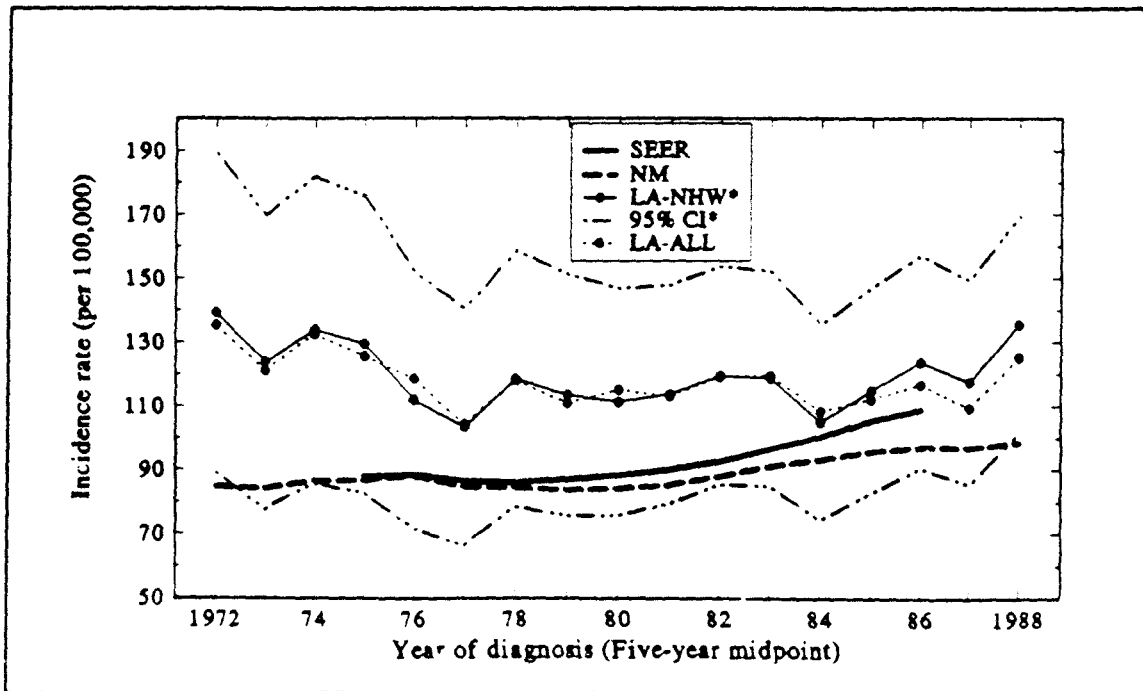

FIGURE D.1.2.4-7.—5-Year Average Annual Incidence of Female Breast Cancer, Los Alamos County, New Mexico NHW, SEER Whites, 1970 to 1990.

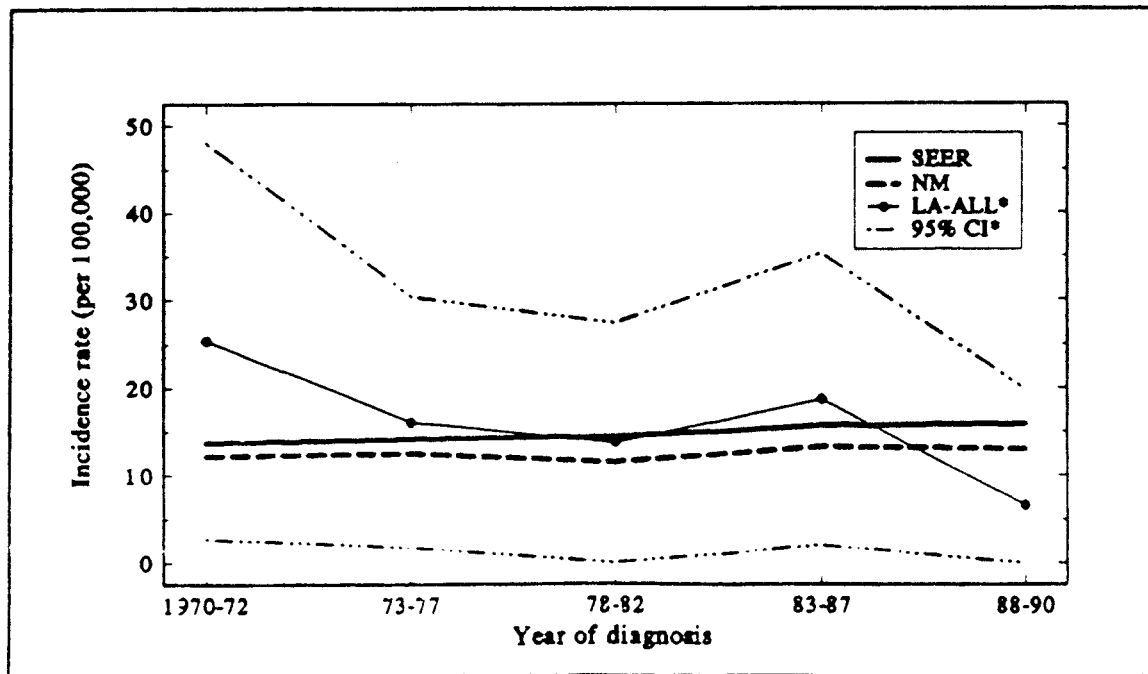

FIGURE D.1.2.4-8.—Average Annual Incidence of Childhood Cancer (0 to 19 Years), Los Alamos County, New Mexico NHW, SEER Whites, 1970 to 1990.^a

^a Incidence rate data based on independent time periods and not 5-year moving averages.

period (1970 to 1972), subsequent periods were characterized by incidence rates that were slightly higher than or lower than the reference incidence rates. Two childhood brain cancer cases not in the original childhood cancer data set were discovered through a supplemental review of childhood cancer mortality statistics. The two additional cases, diagnosed in 1978 and 1980, would raise the original 1978 to 1982 Los Alamos County rate (13.7 per 100,000) by about 50 percent to 20.3 cases per 100,000. For the latest period (1988 to 1990), the incidence of childhood cancers in Los Alamos County was roughly 50 percent lower than that seen in the state reference population; however, the Los Alamos County rate was based on only one case.

Thyroid. The incidence of thyroid cancer in Los Alamos County prior to the mid 1980's was roughly stationary and less than two-fold higher than that seen in the reference populations (Figure D.1.2.4-9). Los Alamos County incidence rates began to rise during the mid

1980's and continued to climb up until the latest time interval (1986 to 1990). The incidence of thyroid cancer in Los Alamos County during 1986 to 1990 was nearly four-fold higher than that observed in the state reference population. The near four-fold elevation for Los Alamos County was statically significant. Roughly half (17 out of 37) of all thyroid cancer cases that occurred in Los Alamos County between 1970 and 1990 were diagnosed during the 1986 to 1990 interval.

Brain and Nervous System. The incidence of brain cancer in Los Alamos County increased over time (Figure D.1.2.4-10). Los Alamos County incidence rates were lower than or comparable to the reference rates up until the mid 1980's. Increases in Los Alamos County brain cancer incidence became apparent during the mid to late 1980's. Los Alamos County incidence rates (all races) during this period were 60 to 80 percent higher than rates for the state and national reference populations. Diagnosed in 1978 and 1980, two additional

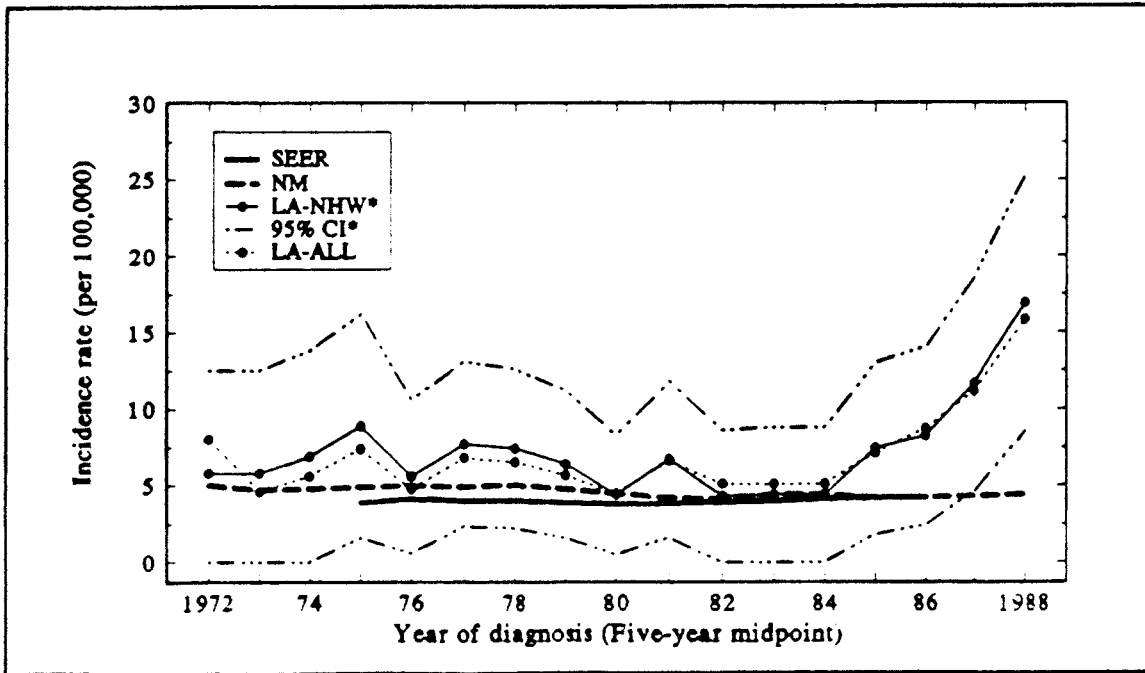

FIGURE D.1.2.4-9.—5-Year Average Annual Incidence of Thyroid Cancer, Los Alamos County, New Mexico NHW, SEER Whites, 1970 to 1990.

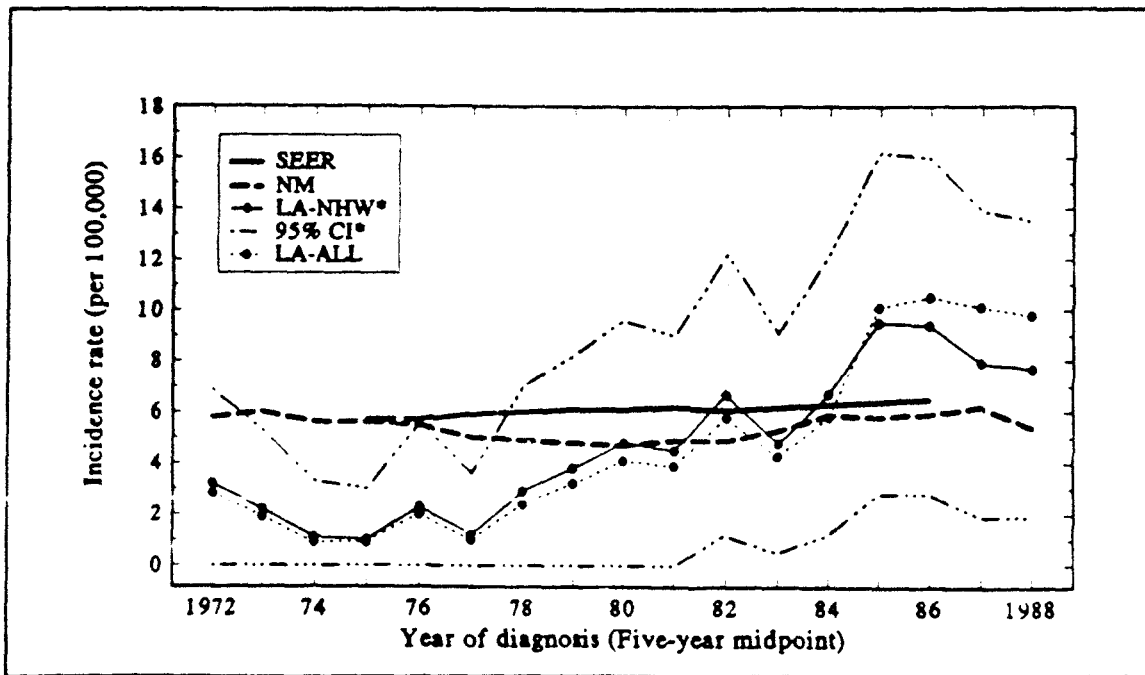

FIGURE D.1.2.4-10.—5-Year Average Annual Incidence of Brain and Nervous System Cancer, Los Alamos County, New Mexico NHW, SEER Whites, 1970 to 1990.

cases raised the central portion of the incidence rate curve to a range more comparable with the reference rates, but had no effect on the rates observed during the period of elevated incidence.

Mortality

Mortality rates for Los Alamos County and the U.S. were obtained as age-adjusted average annual mortality rates from the National Center for Health Statistics (NCHS) and the National Cancer Institute. All rates were standardized to the 1970 U.S. standard population and were race-specific for Whites. Site-specific Los Alamos County mortality rates were available for the periods 1969 to 1972, 1973 to 1977, 1978 to 1982, and 1983 to 1987. U.S. rates were

available for the time period 1968 to 1972. For some cancers, both Los Alamos County and U.S. rates were available for the period 1968 to 1972. The confidence intervals that accompany the mortality rates were calculated as described for the incidence rates. Table D.1.2.4–1 summarizes the mortality rates by cancer type for Los Alamos County. Nationwide rates are also reported for comparison.

Subcounty Cancer Incidence

Table D.1.2.4–2 describes the cancer incidence for the five census tracts within Los Alamos County for all races, 1980 to 1990. The New Mexico non-Hispanic White population rates are provided also.

TABLE D.1.2.4-1.—Average Annual Age-Adjusted Mortality Rates by Cancer Type for Los Alamos County and U.S. Whites (1969 to 1987)

CANCER TYPE	LOCATION	MORTALITY RATE ^a			
		1969 TO 1972	1973 TO 1977	1978 TO 1982	1983 TO 1987
Liver and Bile	Los Alamos	14.6 (2) ^b	0 (0)	5.4 (3)	7.1 (4)
	U.S.	—	2.1	2.1	2.3
Non-Hodgkin's Lymphoma	Los Alamos	13.5 (2)	5.8 (2)	12.0 (6)	2.3 (2)
	U.S.	NA ^c	4.9	5.2	5.9
Leukemia	Los Alamos	1.2 (1)	11.2 (6)	1.3 (1)	4.5 (4)
	U.S.	NA	6.8	6.7	6.5
Melanoma	Los Alamos	0 (0)	6.5 (3)	2.9 (2)	1.0 (1)
	U.S.	1.7	1.9	2.2	2.3
Ovarian	Los Alamos	19.7 (3)	5.7 (1)	8.9 (3)	3.8 (2)
	U.S.	NA	8.6	8.1	7.9
Breast	Los Alamos	39.6 (8)	17.4 (7)	60.7 (20)	29.7 (12)
	U.S.	26.9	26.9	26.6	27.2
Childhood Cancer	Los Alamos	3.6 (1)	12.3 (4)	16.1 (5)	10.6 (3)
	U.S.	6.6	5.4	4.6	4.0
Brain and Nervous System	Los Alamos	0 (0)	6.3 (4)	5.8 (5)	5.8 (5)
	U.S.	NA	4.0	4.1	4.3
Thyroid	Los Alamos	0 (0)	0 (0)	0 (0)	0 (0)
	U.S.	NR ^d	NR	NR	NR

^a Rates per 100,000 and are age-adjusted to the 1970 U.S. standard population.

^b Number of deaths given in parentheses.

^c NA = Not available

^d NR = Not reported

TABLE D.1.2.4-2.—Average Annual Age-Adjusted Cancer Incidence Rates for Sub-County Regions of Los Alamos County, All Races (1980 to 1990)^a

SITE	CENSUS TRACT ^b					CDP ^c		LOS ALAMOS COUNTY	NEW MEXICO NHW ^d
	1	2	3	4	5	LOS ALAMOS	WHITE ROCK		
	Non-Hodgkin's Lymphoma	18.9 (2) {0.0 to 45.6}	4.5 (2) {0.0 to 11.0}	20.4 (5) {2.2 to 38.7}	11.1 (5) {1.2 to 21.0}	16.7 (10) {6.1 to 27.2}	12.6 (14) {5.8 to 19.3}		
Leukemia	1.9 (1) {0.0 to 5.7}	10.3 (4) {0.0 to 20.6}	17.5 (2) {0.0 to 42.2}	5.5 (3) {0.0 to 11.8}	11.8 (7) {2.9 to 20.7}	7.1 (10) {2.6 to 11.6}	11.8 (7) {2.9 to 20.7}	8.5 (17) {4.4 to 12.6}	9.5
Melanoma ^e	33.8 (10) {12.4 to 55.2}	22.0 (10) {8.1 to 35.9}	35.8 (7) {8.7 to 62.9}	13.5 (6) {1.5 to 24.5}	21.7 (11) {8.6 to 34.8}	23.2 (32) {15.0 to 31.4}	21.7 (11) {8.6 to 34.8}	22.0 (43) {15.3 to 28.7}	14.5
Ovary (Female)	76.7 (9) {25.6 to 127.8}	19.4 (4) {0.0 to 38.8}	19.5 (2) {0.0 to 47.0}	14.0 (3) {0.0 to 30.2}	12.7 (4) {0.0 to 25.4}	27.4 (18) {14.5 to 40.3}	12.7 (4) {0.0 to 25.4}	23.0 (22) {13.2 to 32.8}	12.8
Breast (Female)	145.3 (28) {90.4 to 200.2}	120.5 (21) {67.9 to 173.1}	159.2 (16) {79.6 to 238.9}	85.3 (21) {48.1 to 122.5}	116.0 (41) {79.8 to 152.3}	119.8 (86) {93.9 to 145.6}	116.0 (41) {79.8 to 152.3}	119.0 (127) {97.9 to 140.1}	92.2
Childhood (< 20 years)	21.9 (2) {0.0 to 52.8}	6.7 (1) {0.0 to 20.2}	0.0 (0) { - }	24.5 (2) {0.0 to 59.2}	16.9 (4) {0.0 to 33.9}	14.2 (5) {1.5 to 26.9}	16.9 (4) {0.0 to 33.9}	15.2 (9) {5.1 to 25.3}	14.8
Thyroid	16.0 (6) {2.9 to 29.1}	3.8 (2) {0.0 to 9.1}	5.8 (1) {0.0 to 17.5}	8.7 (4) {0.0 to 17.4}	9.3 (9) {3.1 to 15.4}	9.0 (13) {4.0 to 14.0}	9.3 (9) {3.1 to 15.4}	9.8 (22) {5.6 to 14.0}	4.3
Brain	7.3 (2) {0.0 to 17.5}	5.7 (3) {0.0 to 12.4}	14.2 (3) {0.0 to 30.6}	7.4 (2) {0.0 to 18.0}	8.2 (7) {2.0 to 14.3}	7.4 (10) {2.7 to 12.1}	8.2 (7) {2.0 to 14.3}	7.9 (17) {4.1 to 11.7}	5.1

^a Rates are for residence at diagnosis for all races per 100,000, age-adjusted to U.S., 1970 standard population; number of cases in parentheses (); 95% confidence limits in brackets { }, truncated at zero.

^b Census Tract Designations: (1) North/Barranca Mesa; (2) North Community; (3) Western Area; (4) Eastern Area; (5) White Rock.

^c Los Alamos Census Designated Place (CDP) comprises census tracts 1 through 4, White Rock CDP comprises census tract 5.

^d Non-Hispanic Whites

^e Excludes two cases with unknown residence at diagnosis.

Source: New Mexico Tumor Registry

D.2 METHODS USED FOR THE ESTIMATION OF HUMAN HEALTH CONSEQUENCES OF CONTINUED LANL OPERATIONS

The consequences of continued operations of LANL to public health and to LANL workers are evaluated in this SWEIS. The consequence analysis is based on several exposure scenarios that are conservatively defined in order to estimate potential maximum doses and risks (e.g., excess latent cancer fatality [LCF]) to the public and workers under normal operations in each of the four alternatives examined. (The consequences of credible and less than credible accidents on workers and the public are detailed in appendix G.)

D.2.1 Methods Used to Evaluate Public Health Consequences from Routine Operations

Public health consequences of continued LANL operations were based on several exposure scenarios, including exposure to external radiation, inhalation of airborne radioactivity and chemical emissions, ingestion of water and foodstuffs and inadvertent ingestion of sediments and soils, and dose received due to incident-free transportation to or from LANL. The methodology used to estimate dose to the public from external radiation and airborne radioactive and chemical emissions is given in appendix B. The methodology used to estimate dose from transportation to or from LANL is given in appendix F. The methods used to estimate dose, hazard, and cancer risk from radioactive and chemical intakes (inhalation and ingestion) are detailed below.

The estimation of potential dose and risk used in the public health consequence analysis was directed at estimating total risk. That is, the risks posed by all sources, including LANL, other anthropogenic sources, fallout and regional depositions such as through rainfall,

and naturally occurring radionuclides and chemicals, were evaluated. For those radionuclides and chemicals shown to have risk probabilities greater than 1 in 1 million (1×10^{-6}) per year, the relative contribution of LANL operations versus other sources of risk was examined.

D.2.1.1 *Methods for Evaluation for External Radiation Risk and Inhalation Dose/Risk from Airborne Radionuclides and Chemicals*

The exposure pathways for members of the public were estimated for specific exposure scenarios and are “hypothetical” (that is, a person hypothesized to be present for a portion of the time or all the time that is conservatively located rather than by using actual location, such as assuming that a person is resident at the fence line of a facility) members of the public. These include ingestion exposure scenarios for Los Alamos County residents, non-Los Alamos County residents, nonresident recreational users of canyons, resident recreational users of canyons, and people who could be exposed via special pathways. Special pathway exposures are through culturally associated lifestyle patterns such as increased use of herbal teas made from local vegetation, use of locally collected herbal smoking materials, working with clays, or increased consumption of local foodstuffs including game species resident/migrating through the LANL reservation.

External Radiation and Airborne Radioactivity

For radioactive emissions from LANL facilities, population consequences were estimated to a radial distance of 50 miles (80 kilometers). Both point-source and diffuse source emissions were included in the analysis. Using the model CAP-88 (EPA 1992), the direct exposures (the sum of external radiation and inhalation and

ingestion of airborne emissions) were estimated for each of the four alternatives for continued operations of LANL. The maximally exposed individual (MEI) was determined to be near the Los Alamos Neutron Science Center (LANSCE) (appendix B).

For individuals, the risk of excess LCFs was estimated for each alternative based on the recommendations of the International Commission on Radiological Protection (ICRP 1991), which provide the conversion of 0.0005 excess LCFs per rem of exposure (Table D.1.1.2–1).

Toxic Chemicals

Inhalation of airborne chemicals was evaluated on a TA-specific basis in the nonradiological air quality analysis presented in appendix B. The chemicals identified in this screening for public health consequence analysis were reviewed as described in section B.2.3.1.

First, a qualitative evaluation was made of the chemical's reference dose, toxicity, potential carcinogenicity, and chemical form(s) likely in the LANL area (both as released and upon deposition onto soils, waters, and sediments). Several chemicals identified in the very conservative nonradiological air screening process were eliminated from subsequent public health consequence analysis using these qualitative evaluations.

For the remaining chemicals, quantitative evaluation was made based on the modeled predicted concentrations at the nearest location where a member of the public could be exposed. The modeling methods are described in appendix B, as are the results for the modeled chemicals at specific TAs.

The factors used for quantitative analysis are those given in the *EPA Exposures Factors Handbook* (EPA 1997a). The exposure scenario assumed that a member of the public could be exposed to the average and 95th percentile

concentrations of the chemical at that nearest location to the source. Average and worst-case (95th percentile) uptakes were calculated as milligram per kilogram-day for a standard adult human male.

Average and worst-case hazard indices were calculated (EPA 1997a): milligram per kilogram-day estimated per milligram per kilogram-day reference dose for the chemical. In some cases, no reference dose has been provided by EPA's IRIS (EPA 1997b). In instances where carcinogens or suspected carcinogens had no hazard index available, if unit risk factors were available, they were used to estimate potential risk to the MEI.

D.2.1.2 *Methods for Estimation of Ingestion Risks from Radionuclides and Chemicals*

Concentrations of radionuclides and chemicals in environmental media were used in dose/risk analysis. The data used were those from LANL's Environmental Surveillance Reports 1991 to 1996 (appendix C). The 95th percentile upper confidence level (95 percent UCL) values were used in order to provide a conservative analysis (calculated using only measurements above zero or the detection threshold).

Data from specific contaminated sites were used to provide insight to potential additional but short-term exposures that could contribute to dose/risk. These datasets are also provided in appendix C.

Table D.2.1.2–1 presents the specific exposure pathways evaluated for the five exposure scenarios: residents (both Los Alamos and non-Los Alamos County), recreational users (residents and nonresidents), and special pathways. These exposure scenarios are defined below.

TABLE D.2.1.2-1.—Ingestion and Hypothetical Receptors Used to Evaluate Radiological Dose and Potential Public Health Consequence

EXPOSURE PATHWAY	RECEPTOR ^a					SPECIAL PATHWAYS RECEPTORS ^c
	OFF-SITE RESIDENT LOS ALAMOS COUNTY	OFF-SITE RESIDENT NON-LOS ALAMOS COUNTY	NONRESIDENT RECREATIONAL USER ^b	RESIDENT RECREATIONAL USER ^b		
Produce:						
Fruit	ESD	ESD	NA	NA	NA	NA
Vegetables	ESD	ESD	NA	NA	NA	NA
Meat (Cattle: Free-Ranging Steer)	NA	ESD	NA	NA	NA	NA
Milk	ESD	ESD	NA	NA	NA	NA
Fish	NA	ESD	NA	NA	NA	ESD
Honey	ESD	ESD	NA	NA	NA	NA
Elk	ESD ^d	ESD ^d	NA	NA	NA	ESD ^e
Deer	ESD	ESD	NA	NA	NA	TBD
Pinyon Nuts	NA	ESD	NA	NA	NA	NA
Indian Tea (Cota)	NA	NA	NA	NA	NA	ESD
Groundwater	ESD	ESD	NA	NA	NA	NA
Surface Water:						
Creeks	NA	NA	ESD	ESD	ESD	NA
NPDES Discharge	NA	NA	ESD	ESD	ESD	NA
Soils	ESD	ESD	ESD	ESD	ESD	NA
Sediments	ESD	ESD	ESD	ESD	ESD	NA

^a Receptor is a hypothetical person who is conservatively estimated to have intake of the 95th upper confidence limit (UCL) concentration of a contaminant in the specific medium evaluated for ingestion.

^b The resident recreational user lives in Los Alamos County or a neighboring county and is in the Los Alamos canyons 24 visits per year, approximately 8 hours per visit. The nonresident recreational user lives outside the region of influence of LANL but hikes into the canyons 12 visits per year, approximately 6 hours per visit.

^c Special pathways receptors are those who have traditional Native American or Hispanic lifestyles.

^d Elk muscle.

^e Elk heart and liver.

ESD = Environmental Surveillance Data

NA = Not applicable

The doses/risks from ingestion pathways were examined as total ingestion risk, resulting from all contributors to the concentrations of radionuclides and chemicals in foodstuffs, water, and soils/sediments. The concentrations include naturally occurring radionuclides and chemicals, residual contamination from worldwide fallout and earlier LANL operations, and small quantities of contamination from more recent operations. Because it is difficult to differentiate among these sources for most materials, this SWEIS analysis calculates the total risk from all these sources. (If this analysis demonstrated elevated risks from a particular contributor, then it would be investigated to determine its possible sources.)

The exposures through ingestion were calculated using the 95 percent upper confidence limit (UCL) concentrations. In calculating the UCL, all samples of zero or negative value or less than the detection limit were rejected. This significantly increases the average value and the UCL, and especially so when a large fraction of the samples show no detectable contamination. Based on the projected emissions and effluents under the four alternatives (section 3.6), there are no incremental differences in dose/risk from operations continuing at LANL for the next 10 years. Therefore, the ingestion dose/risk analysis was provided only in the No Action Alternative.

The consumption rates used for estimating dose/risks at both 50th and 95th percentile were taken from the *EPA Exposure Factors Handbook* (EPA 1997a, except where only available in 1989 edition). In each dose/risk ingestion analysis provided, the specific data used were identified as well as the intake rates and any conversion factors. Because these differ among radionuclides and chemicals analyzed, they are only provided in the dose/risk analysis detailed tables (section D.3.3).

Off-Site Resident

Two different types of off-site resident were analyzed: one of these represents Los Alamos County residents; the other represents non-Los Alamos County residents and was located near the Otowi Bridge (outside Los Alamos County) in an agricultural area.

Los Alamos County Off-Site Resident.

Because there is no meat or milk production from Los Alamos County, there are no viable meat or milk ingestion pathways for any doses to residents in Los Alamos County. The Los Alamos County resident was assumed to have a garden at his or her home, and it was conservatively assumed that a portion of the resident's produce (fruit and vegetables) was obtained from this garden. The resident in Los Alamos County would use water from the Los Alamos County water supply.

Thus, the pathways for the off-site resident in Los Alamos County would include ingestion of produce, fish, honey, game animals, pinyon nuts, groundwater, and inadvertent ingestion of sediments and soil. Doses for ingestion pathways were primarily determined using the concentrations in the various media measured in LANL environmental surveillance programs (LANL 1992, LANL 1993, LANL 1994, LANL 1995, LANL 1996a, and LANL 1996b). These consumption rates are provided in Table D.2.1.2–2.

Non-Los Alamos County Off-Site Resident.

The exposure pathways that are applicable to this off-site resident are the same as those for the Los Alamos County off-site resident, with the following exceptions. Two additional pathways were evaluated for non-Los Alamos County residents: ingestion of meat and ingestion of milk from sources outside of Los Alamos County but within the LANL region of influence (based on current LANL surveillance data, 1991 to 1996).

TABLE D.2.1.2–2.—Consumption Rates Used for Public Health Consequence Analysis

INGESTION PATHWAY	INGESTION RATE PER YEAR	
	AVERAGE VALUE (50%)	WORST-CASE VALUE (95%)
Produce	202 kg	587 kg
Milk Products	210 liters	778 liters
Meat	55 kg	134 kg
Fish	7 kg	7 kg
Honey	1.4 kg	5.0 kg
Pinyon Nuts	1.5 kg	none given
Water	550 liters	891 liters (90 th percentile)
Soil and Sediments	0.036 kg	0.146 kg
Homegrown Fraction: Vegetables ^a	25%	40%
Homegrown Fraction: Fruit ^a	20%	30%

^a EPA 1989

Recreational Users

The nonresident recreational user was defined in this analysis as a person who occupies on-site canyons during 12 visits per year, for 6 hours per visit. The resident recreational user was hypothesized to be resident in Los Alamos or neighboring counties and to spend an average of 2 visits per month, 8 hours per visit, in the canyons as an avid local outdoor enthusiast.

Special Pathways

Special pathways were also evaluated to assess potential impacts to Native American, Hispanic, and other traditional lifestyle receptors that might not be bounded by the hypothetical MEIs of residents and recreational users. The following exposure pathways were evaluated:

- Ingestion of game animals from the LANL area
- Ingestion of fish from the Cochiti reservoir
- Ingestion of native vegetation through the use of herbal teas
- Dermal absorption of sediments during craft or ceremonial use of clays

- Inhalation of local herbaceous plant materials via smoking
- Ingestion of surface waters from LANL
- Ingestion of soils and sediments from LANL
- Ingestion of locally grown produce

After investigations via interviews, it was determined that potential dermal absorption of contaminants from use of native clays for pottery is not a viable pathway. Clays are taken from specific areas and at depths that are not subject to appreciable contamination. Also, it was determined that potential uptakes via bathing or ceremonial uses of springs is not a viable pathway at LANL because there are no known permanent springs of sufficient size for such use. Finally, smoking use of herbs was not evaluated as a pathway because these are used in concert with tobaccos and do not significantly differ in risk than the risk posed by commercial tobacco use.

D.2.2 Worker Health

The methods used to estimate potential consequences to the health of workers from continued operations of LANL are given below.

These methods address: ionizing and nonionizing radiation, chemical exposures, and physical safety hazards during normal operations in LANL. The methods and consequences of accidents are addressed in appendix G.

D.2.2.1 Radiological Consequences to Workers

The worker radiation dose projected for this SWEIS is the total effective dose equivalent incurred by workers as a result of routine operations. The dose is the sum of the external whole body dose as monitored by personnel dosimeters, including dose from both photons and neutrons, and internal dose, as required by 10 CFR 835. The internal dose is the 50-year CEDE. However, the internal dose being projected is that for tritium, and does not include dose from incidents with plutonium or other nuclides. The internal dose from inhalation of plutonium occurs almost entirely from a breakdown of control or equipment, and is not predictable. Past plutonium exposures, such as the examples described in chapter 4 of volume I (Table 4.6.2.1.–1), are reported to DOE and have been included in the 1993 to 1995 baseline. Note that in 1996, plutonium produced measurable dose in two workers, contributing 4.8 person-rem to the worker collective dose. These incidental exposures are small compared to the total collective dose, which runs about 200 person-rem.

The collective doses for each LANL group and contractor, as monitored by the LANL Radiation Protection Program, were collected for 1993, 1994, and 1995 (LANL 1995, LANL 1996a, and LANL 1996b). The collective doses for the 3 years were summed for each group, and the groups were ranked by their total collective doses. Because of a major LANL reorganization in 1993 and 1994, many groups that were operating in 1993 and 1994 disappeared in 1995. Their functions were typically assumed by another group. This did

not affect the major groups receiving radiation doses at LANL, which are listed in Table D.2.2.1–1 except for some groups at LANSCE (then called the Los Alamos Meson Physics Facility [LAMPF]). For these exceptions, the old groups were tracked to their new LANSCE counterparts through interviews with LANSCE personnel.

The 12 groups with the greatest total collective doses from 1993 through 1995 comprised more than 80 percent of the total collective dose for all LANL workers during that period. In addition to these 12 groups, groups that contributed more than 1 percent of the total LANL collective dose during this timeframe were interviewed to determine whether they would become major contributors to the collective dose in the future.

This process resulted in the identification of 15 groups that combined to contribute more than 84 percent of the collective LANL worker dose from 1993 to 1995 (Table D.2.2.1–1). These groups are included in the detailed radiation dose projections and analyses under each of the four SWEIS alternatives, based on the alternative descriptions and on historical exposure information. The following data were obtained for each of these groups:

- The group collective dose under each SWEIS alternative
- The group total collective dose from all programs for each alternative
- The number of workers with nonzero doses for each of the alternatives, as defined by LANL (Workers with measurable doses are referred to as nonzero dose workers.)

In order to obtain the total number of workers with nonzero dose for the entire laboratory, the index data were used to calculate a ratio of the number of workers with nonzero doses to the total number of workers monitored for radiation doses for the entire laboratory. Approximately 51 percent of the workers receiving a nonzero dose belong to the 12 groups that received the

TABLE D.2.2.1-1.—Groups Used in the Projection of the Worker Doses

RANK	GROUP	PERCENT OF LANL COLLECTIVE DOSE (1993 TO 1995)	CUMULATIVE PERCENT OF LANL COLLECTIVE DOSE (1993 TO 1995)^a	KEY FACILITY
1	Operational Health Physics	17	17	LANL-wide
2	Actinide Ceramics and Fabrication	14	30	TA-55
3	Nuclear Materials Management	11	41	TA-55
4	LANL Craft Subcontractor	8.9	50	LANL-wide
5	Actinide Process Chemistry	8.7	59	TA-55
6	Weapons Component Technology ^b	8.2	67	TA-55
7	Particle Physics Studies	4.0	71	LANSCE
8	Weapons Component Technology ^b	2.9	74	TA-55
9	Target Area Maintenance	2.6	76	LANSCE
10	Facility Management Operations	1.9	78	TA-55
11	Actinide Research and Development	1.6	80	TA-55
12	Beam Alignment and Maintenance	1.5	81	LANSCE
13	Advanced Nuclear Technology	1.3	83	TA-18
14	Weapons Neutron Research/Manuel Lujan Center Experimenters	1.0	84	LANSCE
15	LANSCE Experimenters ^c	0.7	84.4	LANSCE

^a Numbers may not total exactly due to rounding.

^b These groups were combined in 1996.

^c Refers to a group of workers and not to the entire key facility known as LANSCE.

largest dose from 1993 to 1995, and 49 percent belong to the rest of the laboratory.

Once the above group data were collected, the following steps were taken to determine the worker collective dose, the average nonzero worker dose, and the cancer risk associated with these doses:

- For each alternative, the dose projections for the groups listed in Table D.2.2.1-1 were totaled. The sum was then divided by 0.844 (the fraction of the total laboratory dose comprised by these groups from 1993 to 1995) to estimate the total collective dose for LANL.
- The total collective dose was then divided by the fraction of workers projected to have nonzero doses to obtain the average

nonzero worker dose for the entire laboratory.

- A dose-to-risk conversion factor of 4×10^{-4} excess LCF per person-rem (Table D.1.1.2-1) was used to determine the risks associated with the above doses in Table D.2.2.1-2.

It should be noted that actual doses received by workers will vary to some degree based on the actual work assignments made at LANL. For example, the Particle Physics Studies group may again become involved in activities at LANSCE and may again incur some worker dose. Other groups may incur more or less dose than is projected using this methodology. The approach taken in this analysis is considered conservative (in particular, use of the 0.844 normalization factor changes the entire LANL

TABLE D.2.2.1–2.—Worker Dose for Baseline and Alternatives

ALTERNATIVE	COLLECTIVE DOSE (PERSON-REM/ YEAR)	COLLECTIVE EXCESS LCF RISK (LCF/YEAR)	AVERAGE DOSE (MILLIREM/ YEAR)	INDIVIDUAL EXCESS LCF RISK (LCF/YEAR)
Baseline (1993 to 1995)	208	0.083	0.097	3.9×10^{-5}
No Action	446	0.178	0.135	5.4×10^{-5}
Expanded Operations	833	0.333	0.235	9.4×10^{-5}
Reduced Operations	170	0.068	0.083	3.3×10^{-5}
Greener	472	0.189	0.141	5.6×10^{-5}

collective worker dose in a manner proportional to the changes incurred by the 15 groups with the greatest doses).

The collective and average measurable dose for the No Action Alternative are larger than those for the baseline. This is because the No Action Alternative includes projects that are not now being performed and that were not performed in 1993 to 1995. The average dose is expected to increase significantly in the Expanded Operations Alternative because the programs are expected to expand at a greater rate than is the number of radiation workers. As noted earlier, the dose projections include the doses from external radiation and tritium, but not from other radionuclides (such as plutonium). This is because past and present bioassay for radionuclides within the body are not sensitive to the low intakes typical of normal operations. A new method having significantly improved sensitivity for analyzing bioassay samples is now under development. This will not change the dominance of external radiation and tritium, however, but will permit a more accurate quantification of the internal doses from other radionuclides.

Despite the appearance in Table D.2.2.1–2 of the three significant digits that resulted from the process, the projected doses are, at best, only approximations. The parameters that affect the dose estimates have considerable variability, such as whether a program will be funded and at what level, what the final work practices will be,

and mitigating factors such as shielding and controls that will be employed in implementing the as low as reasonably achievable (ALARA) process. Because of these uncertainties, an attempt was made to maximize the estimates given here by using the upper limit of the dose that could arise from a particular operation. This may have had an effect on the differences between the alternatives, but not likely upon their relative ranking as to worker dose. In any case, for all alternatives the average individual worker dose and the administrative control level for the individual are much lower than the standard of 5 rem per year.

DOE (10 CFR 835) requires that the ALARA process be applied to reduce worker exposure to ionizing radiation. The DOE also has set an administrative control level of 2 rem per year for an individual worker exposure, and LANL has set a level of 1 rem per year. These levels can be intentionally exceeded only with higher level management approvals.

Occasionally, however, individual radiation workers might be given permission to exceed this level if sufficient justification exists. It is not anticipated that any of the groups will request permission to exceed the DOE administrative control level (ACL) of 2 rem per year. Therefore, the maximum worker dose for any of the SWEIS alternatives was estimated to be approximately 1.95 rem per year for the purposes of this SWEIS. This maximum dose estimate would not vary across alternatives and

would remain below 5 rem per year in the absence of accidental exposures.

D.2.2.2 *Nonionizing Radiation Consequences to Humans and Other Biota*

A review of the LANL OSHA 200 Logs (LANL 1990 to 1996) and of DOE's Occurrence Reporting and Processing System (ORPS) reports (LANL 1990 to 1995) was performed to identify any reported injuries to workers from nonionizing radiation. Because there are no incidences of nonionizing radiation injuries to workers, a hypothetical analysis of a worst-case exposure was hypothesized for the SWEIS.

In order to perform this analysis, a methodology was needed to relate a transmitter output to biological effect. The methodology developed was consistent with NCRP 67 (1981), NCRP 86 (1986) NCRP 119 (1993), Cember (1996), and Calder (1984). A spreadsheet was developed that allows the input of transmitter parameters (power, frequency, and antenna size), receptor parameters (exposure area, organism density, organism specific heat rate), and exposure parameters (distance and exposure time) to be used to determine the rise in receptor temperature due to an exposure. Additionally, the spreadsheet was used to determine the power densities at specific distances or the distance to a specific power density.

Four typical targets of interest were chosen for microwave radiation exposure at the TA-49 microwave transmitter: human, to represent both workers and the public at the nearest potential exposure point; zone-tailed hawk, to represent birds of all sizes in the Jemez Mountains; coyote, to represent middle-range animals; and elk, to represent large grazing animals. Exposure duration is governed by the operation of the microwave transmitter and is typically limited to short bursts. These give the range of potential effects of nonionizing radiation on higher order complex animals.

The area immediately around the transmitter(s) is secured. The closest that a member of the general public can get to a transmitter is approximately 1,640 feet (500 meters) to the southwest, along State Route 4. By procedure, all microwave experiments are directed east, away from State Route 4. Procedures do not permit directing the microwave beam above the horizontal plane. On site, the downrange microwave beam path is secured to a distance of 3,280 feet (1,000 meters). The receiving antenna(s) can be positioned anywhere along the beam path. Beyond 3,280 feet (1,000 meters), the beam path is uncontrolled other than by the remoteness of the facility.

The results are expressed as increased body temperature as a result of a short burst exposure. This estimate is conservative because even exposure to 1 second from the source is extremely unlikely. Results for potential microwave exposures for the targets of interest are given in Table D.2.2.2-1. Beyond the distances given in Table D.2.2.2-1, and more typical of the distances humans would be from the microwave source, body temperature increase would be less than that given in the table.

There is no increase in body temperature of humans or other animals evaluated for a 1-second exposure to microwaves. The negligible consequences resulting from body temperature rise of a target would not approach any critical metabolic temperature. However, body temperature changes could be greater if the person or animal were exposed for long periods, or were closer to the source, or if there were increased power output.

D.2.2.3 *Chemical Exposures Consequences to Workers*

There have been no fatal or disabling chemical exposures at LANL in the 1990's, and there is no reason to expect that this would change under any of the alternatives analyzed in this SWEIS.

TABLE D.2.2.2-1.—Temperature Rise Due to Microwave Exposure (1-Second Exposure Duration)

TARGET	DISTANCE IN FEET (METERS)	BODY TEMPERATURE RISE (°C)
Zone-Tailed Hawk	1,640 (500)	0.016
Coyote	3,280 (1,000)	0.0055
Elk	3,280 (1,000)	0.0036
Human	1,640 (500)	0.021
	3,280 (1,000)	0.0052

°C = degrees centigrade

It is anticipated that there would continue to be a few, less serious exposures annually, particularly exposures to: airborne asbestos, lead paint particulates, crystalline silica, fuming perchloric acid, hydrofluoric acid, or skin contact with acids or alkalis. These would be similar to those listed in Table 4.6.2.1-2.

Rates of such chemical exposures were projected by alternative on the basis of changes in the LANL worker population. During the recent years (1990 to 1996) reportable chemical exposures occurred at a rate of one to three incidents per year at LANL, and the worker population was approximately 9,000 individuals. Therefore, the current rate of injuries was used to estimate the number of injuries occurring during continuing operations of LANL, assuming the same rate is experienced in the projected workforce for each of the four alternatives. Although LANL has undertaken a chemical hygiene program that should reduce the rate of chemical exposures in the future, this methodology assumes no additional benefits from implementation of this program.

Beryllium

There is an ongoing beryllium worker monitoring program at LANL within the facility (Sigma) where beryllium is processed in quantities and chemical forms posing worker hazards.

The Chronic Beryllium Disease (CBD) Program Plan elements consist of conducting a baseline inventory and sampling, conducting hazard assessments, conducting exposure monitoring, reducing and minimizing exposures, conducting medical surveillance, providing training, keeping records, and providing performance feedback. Exposure reduction and minimization includes reducing airborne levels of beryllium as-low-as-practical, minimizing the number of current workers exposed and potentially increasing the number of early treatment options that may slow the progression of CBD and reduce health impacts and reduce mortality incidence. The disability associated with CBD is believed to be minimized by early detection of the disease. Workers sensitized to beryllium or with CBD are offered placement in positions without beryllium exposure to maintain employment, and are assured of secure benefits that provide medical care.

The presentation and progression of CBD are highly variable. A percentage of individuals with positive peripheral blood beryllium-induced lymphocyte proliferation test (Be-LPT) results go on to be diagnosed with CBD even though clinical signs and symptoms of CBD are not present at the time of the test.

The qualitative consequence analysis presented in chapter 5 was based on (1) engineering controls and the health and safety program to be implemented when the Beryllium Technology Center is opened in late 1998, and (2) industry standards and exposure limits under OSHA, as

well as recommendations of American Conference of Governmental Industrial Hygienists (ACGIH) and National Institute for Occupational Safety and Health (NIOSH). These are summarized below.

OSHA Beryllium Exposure Limits

The OSHA General Industry Standard (20 CFR 1910.1000) establishes the following permissible exposure limits for beryllium:

- *8-Hour Time Weighted Average, 2 micrograms per cubic meter*—An employee's exposure to beryllium and its compounds in any 8-hour work shift of a 40-hour work week shall not exceed 2 micrograms per cubic meter.
- *Acceptable Ceiling Concentration, 5 micrograms per cubic meter*—An employee's exposure to beryllium and its compounds shall not exceed at any time during an 8-hour shift the 5 micrograms per cubic meter acceptable ceiling concentration limit.
- *Acceptable Maximum Peak Concentration, 25 micrograms per cubic meter*—An employee's exposure to beryllium and its compounds shall not exceed 25 micrograms per cubic meter, the acceptable maximum peak above the acceptable ceiling concentration, for a maximum duration of 30 minutes.

These exposure limits are repeated in 29 CFR 1926 for construction and were adopted from the American National Standards Institute (ANSI) standard, ANSI Z37.29-1970.

OSHA has specific beryllium requirements for welding and cutting on beryllium-containing base or filler metals in 29 CFR 1910.252(c)(8):

Welding or cutting indoors, outdoors, or in confined spaces involving beryllium-containing base or filler metals shall be done using local exhaust ventilation and airline respirators unless atmospheric

tests under the most adverse conditions have established that the workers' exposure is within the acceptable concentrations defined by 29 CFR 1910.1000. In all cases, workers in the immediate vicinity of the welding or cutting operations shall be protected as necessary by local exhaust ventilation or airline respirators.

These requirements are repeated in 29 CFR 1926 for construction activities. In addition, OSHA Technical Manual CPL 2-2.20B references beryllium in Chapter 1, "Personal Sampling for Air Contaminants," Appendix 1-E, "Sampling for Special Analyses," under "Samples Analyzed by Inductively Coupled Plasma" and in Chapter 2, "Sampling for Surface Contamination," which suggests swipe sampling of surfaces since accumulated toxic materials such as beryllium "may become suspended in air, and may contribute to airborne exposures. Bulk and wipe samples are used as aids in determining this possibility."

NIOSH Recommendation for Beryllium

The NIOSH Recommended Exposure Level (Ceiling) is 0.5 $\mu\text{g}/\text{m}^3$.

NIOSH also identifies beryllium as an occupational carcinogen.

American Conference of Governmental Industrial Hygienists Beryllium TLV

The ACGIH has established a threshold limit value (TLV) for beryllium and beryllium compounds. The TLV 8-hour TWA is 2 micrograms per cubic meter. The ACGIH lists beryllium and beryllium compounds as an A1 carcinogen, a confirmed human carcinogen. ACGIH explains this classification in their documentation of TLVs by indicating that the weight of evidence supports the view that beryllium is a confirmed human carcinogen but is of such low potency that only persons exposed to levels similar to those existing in the

Lorain and Reading plants in the 1940's would be at significant risk of developing lung cancer¹ (ACGIH 1997).

The ongoing medical surveillance program provides assurance that the processing level industrial hygiene monitoring measures are effective at detecting any beryllium exposure during beryllium operations. Worker exposure to beryllium from HE processing and testing would be the same as that experienced by the public and is discussed in section D.3.2.

D.2.2.4 Worker Physical Safety Consequences

Rates of accidents and injuries which are potentially within normal operations at LANL were projected by alternative on the basis of

changes in the LANL worker population. Physical hazards include exposures to such hazards as slow leaks from compressed air cylinders of toxic gases such as acetylene, used in welding, or small "pony" bottles of specialized gases used in chemical processing or bench-scale research and development. Electrical hazards, industrial hazards associated with building maintenance and renovation, and ergonomic hazards are typical throughout LANL facilities and field sites. During 1995, reportable accidents and injuries occurred at a rate of 4.6 per 100 workers at LANL, and this rate was used in the SWEIS analyses to generate Table D.2.2.4-1. Although LANL has initiated a program to improve worker health and safety performance, no credit was taken for implementation of this program in the projections of accidents and injuries.

¹ As an example, data for the Lorain plant found exposures ranging from 411 micrograms per cubic meter ($\mu\text{g}/\text{m}^3$) in the general area near a mix operation to 43,300 $\mu\text{g}/\text{m}^3$ in the breathing zone at an alloy operation.

TABLE D.2.2.4-1.—Projected Recordable Cases per Alternative at LANL

ALTERNATIVE	WORKER POPULATION	PROJECTED RECORDABLE CASES	PERCENT CHANGE FROM BASE CASE
Base Case	9,081	418	--
No Action	9,667	445	6.5
Expanded Operations	11,003	507	21.3
Reduced Operations	9,052	417	-0.2
Greener	9,656	445	6.5

D.3 ANALYSIS OF POTENTIAL PUBLIC HUMAN HEALTH CONSEQUENCES DUE TO THE CONTINUED OPERATION OF LANL

This section presents the detailed analyses performed with regard to the potential for the continued operation of LANL to affect public health.

D.3.1 Public Health Consequence Analysis

The analysis presented on human health consequences is extremely conservative. That is, DOE has used as a methodology to identify possible consequences based on maximum concentration estimates of radionuclides and chemicals in the environment, maximum exposure durations, and maximum estimates of ingestion or inhalation intake rates. The slope factors used to estimate carcinogenic risk and the reference doses used to estimate hazard indices, as well as the unit risk concentration used to evaluate outcomes were all established by EPA to be protective of human health, and therefore, include safety factors in order to avoid potential underestimation of impacts.

The conservatism is used in analysis of potential consequences because of the high degree of uncertainty associated with attempting to realistically estimate exposure, resulting dose, and resulting health effects. Therefore, the resulting values of risk (such as excess LCFs or hazard index) are believed to be worst-case consequences to a hypothetical receptor. The hypothetical receptor is not a person living in the community but an analytical construct representing a person who would be in the location of maximum concentrations of radionuclides or chemicals, take the maximum amounts of these contaminants into the person's body, and experience the worst outcome.

Uncertainties in public health consequence analysis include:

- Actual exposures to radionuclides and chemicals in each exposure pathway (inhalation, ingestion and immersion)
- Exposure durations to radionuclides and chemicals present in low concentrations in air, soils and sediments, water, and foodstuffs
- Variability among humans in reaction to exposure to radionuclides and chemicals
- Synergisms among chemicals/radionuclides in the exposed person, synergisms between chemical/radionuclides and natural phenomena (such as solar radiation and exposure to ultraviolet sources, as well as inhalation of radionuclides from LANL operations), and interactions between some chemicals/radionuclides and other stressors or behaviors such as smoking

D.3.1.1 *Inhalation Radiological Doses Estimated to the Public from LANL and Specific Key Facilities Under the Four Alternatives for Continued Operations*

The methods used to estimate the radiological dose from air emissions from specific facilities and from LANL as a site are summarized in sections 5.1.4 and 5.1.6 and are detailed in appendix B. The estimated doses to both the facility-specific and LANL-wide MEI are presented in Table D.3.1.1–1 for each of the four alternatives for continued operations. These values are also presented by alternative in sections 5.2.6.1 (No Action), 5.3.6.1 (Expanded Operations), 5.4.6.1 (Reduced Operations), and 5.5.6.1 (Greener). As detailed in section 5.1.6 and appendix D, section D.2, the ICRP methodologies for estimated cancer risk per rem dose received were applied to these estimates and are reported in chapter 5 in the referenced sections.

TABLE D.3.1.1-1.—Facility-Specific and LANL-Wide MEI Doses and 50-Mile (80-Kilometer) Population Doses from LANL Continued Operations^a

FACILITY	MEI DISTANCE FT (M) ^b	MEI DIRECTION ^b	NO ACTION MREM/YR	EXPANDED OPERATIONS MREM/YR	REDUCED OPERATIONS MREM/YR	GREENER MREM/YR
CMR (TA-3-39)	3,576 (1,090)	N	0.43	1.32	0.36	0.35
Sigma (TA-3-66)	3,560 (1,085)	N	0.43	1.32	0.36	0.35
Machine Shops (TA-3-102)	3,379 (1,030)	N	0.34	1.02	0.29	0.28
HE Testing (TA-11)	4,298 (1,310)	S	0.31	0.73	0.31	0.31
HE Testing (TA-15 and TA-36)	7,415 (2,260)	NE	2.26	4.99	1.76	2.17
WETF (TA-16)	2,886 (880)	SSE	0.31	0.70	0.22	0.31
Pajarito Site (TA-18)	2,821 (860)	NE	1.73	4.39	1.51	1.93
TSTA/TSFF (TA-21)	1,050 (320)	N	1.41	2.55	1.22	1.54
Radiochemistry (TA-48)	2,920 (890)	NNE	1.66	3.67	1.08	1.64
LANSCE (TA-53)	2,625 (800)	NNE	3.11	5.44	1.88	4.52
Area G (TA-54)	1,197 (365) bndry 5,331 (1,625) WR	NE SW	0.75 0.43	1.81 1.07	0.68 0.39	0.79 0.45
Plutonium Facility (TA-55)	3,691 (1,125)	N	1.66	3.67	1.08	1.64
LANL-Wide MEI	2,625 (800) ^c	NNE	3.11	5.44	1.88	4.52
Regional Population Dose	50-mi (80-km) radius		13.59	33.09	10.83	13.79

^a Source: Appendix B, sections B.1.1 and B.1.2.

^b MEI direction and distance are from the stated facility.

^c The LANL-wide MEI is the LANSCE MEI.

CMR = Chemistry and Metallurgy Research, HE = high explosives, WETF = Weapons Engineering Tritium Facility, TSTA = Tritium System Test Assembly, TSFF = Tritium Science and Fabrication Facility

D.3.1.2 Public Radiological Doses from Ingestion for all Four Alternatives

The methodology for estimating the public doses through ingestion is described in section D.2.1.2. Because there is no release that would increase existing concentrations in the environmental media comprising the ingestion pathways (food, soil, sediment, water), the projected doses are the same for the baseline and all four alternatives. These are given in Table 5.2.6.1–2 for an average (50th percentile) intake of contaminated media, and in Table 5.2.6.1–3 for the worst-case (95th percentile) consumption of contaminated media.

D.3.2 Analysis of Public Health Consequences from High Explosives Testing Site Chemical Emissions

In applying the nonradiological air quality methodology as presented in section 5.1.4.1, three chemicals (depleted uranium, beryllium, and lead) were identified from one or more of four TAs (TA–14, TA–15, TA–36 and TA–39) in which high explosives are tested as being of sufficient concentrations to require human health analysis. While a few other metals were identified using the screen (appendix B, section B.2), their reference doses (EPA 1997b) were high, potential concentrations in air were overestimated using the conservative screening methodologies applied, and have low toxicities and low probabilities of carcinogenicity.

Therefore, they were not quantitatively evaluated for human health consequences. These metals were:

- Aluminum
- Copper
- Iron
- Tantalum
- Tungsten

The modeling used to estimate exposures to the public from HE chemical emissions under the No Action and Expanded Operations Alternatives is presented in section 5.1.4.1 and detailed in appendix B (sections B.2.3.2 and B.2.3.3). (The quantities of expended materials were the same for the Reduced Operations and Greener Alternatives as for No Action.)

Tables D.3.2–1 (No Action, Reduced Operations, and Greener) and D.3.2–2 (Expanded Operations) present the results of the modeling performed to estimate the concentration of specific chemicals at the MEI location for each TA. The chronic daily uptake was calculated as presented in appendix D.2.1 for both the average uptake and worst-case uptake, using EPA's *Exposure Factors Handbook* (EPA 1997a). The hazard index is presented for uranium and lead, based on the reference dose give in EPA's Integrated Risk Information System (EPA 1997b). A hazard index of 1 or greater than one is considered indicative of a potential health hazard to exposed individuals. EPA has not published a reference dose for inhalation of beryllium. Therefore, a hazard index could not be calculated for beryllium.

TABLE D.3.2-1.—Analysis of Public Health Consequences from Specific Chemicals Emitted from the High Explosives Test Areas (TA-14, TA-15, TA-36, and TA-39) in the No Action, Reduced Operations, and Greener Alternatives^{a,c}

TECHNICAL AREA	CHEMICAL	ANNUAL RESPIRABLE EMISSION RATE (kg/yr)	MODELED HOURLY EMISSIONS RATE (g/sec)	CONCENTRATION AT MEI LOCATION ($\mu\text{g}/\text{m}^3$)	CHRONIC DAILY UPTAKE AVERAGE (mg/kg-day)	CHRONIC DAILY UPTAKE WORST CASE (mg/kg-day)	HAZARD INDEX AVERAGE	HAZARD INDEX WORST CASE
TA-14	Depleted Uranium	1.0	3.0E-5	< 1.0E-5	< 2.2E-9	< 4.2E-9	< 1.6E-6	< 3.0E-6
	Lead	1.0	3.0E-5	< 1.0E-5	< 2.2E-9	< 4.2E-9	< 4.9E-6	< 9.8E-6
	Beryllium	1.0	3.0E-5	< 1.0E-5	< 2.2E-9	< 4.2E-9	b	b
TA-15	Depleted Uranium	90	2.9E-3	1.5E-4	3.2E-9	6.2E-9	2.3E-6	4.5E-6
	Lead	5	1.7E-4	1.0E-5	2.1E-9	4.2E-9	4.9E-6	9.7E-6
	Beryllium	1.0	3.0E-5	< 1.0E-5	< 2.2E-9	< 4.2E-9	b	b
TA-36	Depleted Uranium	40	1.3E-5	1.3E-4	2.8E-8	5.4E-8	2.0E-5	3.9E-5
	Lead	1.0	3.0E-5	< 1.0E-5	< 2.1E-9	< 4.2E-9	< 4.6E-6	< 9.8E-6
	Beryllium	1.0	3.0E-5	< 1.0E-5	< 2.1E-9	< 4.2E-9	b	b
TA-39	Lead	1.0	3.0E-5	< 1.0E-5	< 2.1E-9	< 4.2E-9	< 4.9E-6	< 9.8E-6
	Beryllium	1.0	3.0E-5	< 1.0E-5	< 2.1E-9	< 4.2E-9	< 4.9E-6	< 9.8E-6

Source: Appendix B, sections B.2.3.2 and B.2.3.3.

^a Depleted uranium, beryllium, and lead were identified in the nonradiological air quality evaluation as requiring public health consequence analysis under the Expanded Operations Alternative. For the No Action, Reduced Operations, and Greener Alternatives, emissions were estimated as one-third that of the Expanded Operations emissions based on the annual expenditures of materials projected for these alternatives for continued HE testing.

^b There is currently no reference dose for beryllium inhalation (EPA 1997b); therefore, no hazard index could be calculated. Based on the inhalation unit risk factor (EPA 1997b) of 2.4E-3 per $\mu\text{g}/\text{m}^3$, the maximum beryllium carcinogenic risk would be < 3.6E-8/year.

^c Values rounded to 2 significant figures.

TABLE D.3.2-2.—Analysis of Public Health Consequences from Specific Chemicals Emitted from the High Explosives Test Areas (TA-14, TA-15, TA-36, and TA-39) in the Expanded Operations Alternative (Values Rounded to 2 Significant Digits)^a

TECHNICAL AREA	CHEMICAL	ANNUAL RESPIRABLE EMISSION RATE (kg/yr)	MODELED HOURLY EMISSIONS RATE (g/sec)	CONCENTRATION AT MEI LOCATION ($\mu\text{g}/\text{m}^3$)	CHRONIC DAILY UPTAKE (mg/kg-Day) AVERAGE	CHRONIC DAILY UPTAKE (mg/kg-Day) WORST CASE	HAZARD INDEX AVERAGE	HAZARD INDEX WORST CASE
TA-14	Depleted Uranium	3.1	1.0E-4	< 1.0E-5	< 2.1E-9	< 4.2E-9	< 1.5E-6	< 3.0E-6
	Lead	3.1	1.0E-4	< 1.0E-5	< 2.1E-9	< 4.2E-9	< 4.9E-6	< 9.8E-6
TA-15	Beryllium	3.0	1.0E-4	1.0E-5	2.1E-9	4.2E-9	b	b
	Depleted Uranium	270	8.6E-3	4.3E-4	9.1E-8	1.8E-7	6.5E-5	1.3E-4
	Lead	15	5.0E-4	3.0E-5	6.4E-8	1.3E-8	1.5E-5	2.9E-5
TA-36	Beryllium	3.0	1.0E-4	1.0E-5	2.1E-9	4.2E-9	b	b
	Depleted Uranium	120	3.8E-3	3.9E-4	8.3E-8	1.6E-7	5.9E-5	1.2E-4
	Lead	3.0	1.0E-4	1.0E-5	2.2E-9	4.2E-9	4.9E-6	9.7E-6
TA-39	Beryllium	3.0	1.0E-4	1.0E-5	2.2E-9	4.2E-9	b	b
	Lead	3.0	1.0E-4	1.0E-5	2.2E-9	4.2E-9	4.9E-6	9.7E-6

Source: Appendix B, sections B.2.3.2 and B.2.3.3.

^a Depleted uranium, beryllium, and lead were identified in the nonradiological air quality evaluation as requiring public health consequence analysis under the Expanded Operations Alternative.

^b There is currently no reference dose for beryllium inhalation (EPA 1997b); therefore, no hazard index could be calculated. Based on the inhalation unit risk factor (EPA 1997b) of 2.4E-3 per $\mu\text{g}/\text{m}^3$, the beryllium carcinogenic risk would be approximately 3.6E-8/year.

^c Values rounded to 2 significant figures.

D.3.3 Estimates of Dose and Risk from Radiological and Metallic Contaminants Potentially Ingested by Residents, Recreational Users of LANL Lands, and via Special Pathways

The methodology for estimating dose and risk from contaminants that could be ingested as or with food and water is given in section 5.1.6 and detailed in appendix D, section D.2.1.2. The data on which the estimates of ingestion and risk were based were environmental surveillance data, which are presented in appendix D, section D.3.5.

Each table presented in this section (Tables D.3.3–1 through D.3.3–50, provided as an attachment to this appendix) contains the concentration data used for calculations. The 95 percent UCL was used for the concentrations. The 95 percent UCL was determined as the average value, plus twice the standard deviation. In calculating the UCL, all samples of zero or negative value or less than the detection limit were rejected. This significantly increases the UCL, and especially so when a large fraction of the samples show no detectable contamination. In other words, in this conservative approach, a few samples that show measurable contamination will receive disproportionate weighting in the distribution. Both the average intake and worst-case intake were estimated using EPA's *Exposures Factors Handbook* (EPA 1997a). All dose conversion factors are given in the tables.

These tables represent the risk estimated from all alternatives based on ingestion. The risk factors used are conservative and represent the upper bound of the risk. The risk is uncertain and could be much smaller, as discussed in section D.1.1.8. Note that for ingestion pathways, exposure limits for exposure by inhalation are not applicable. There are no

estimated differences in contaminant levels that would result from implementation of any of the four alternatives for continued operations. There is a discussion of concentrations of radiological and metallic contaminants in media in the region of Los Alamos versus background concentrations of these in the region presented in section D.3.4. Total risks estimated for ingestion are presented in chapter 5, specifically in section 5.2.6.1 (No Action).

D.3.3.1 *Potential Exposures to Tritium via Los Alamos Canyon*

As a result of recent studies and concerns with regard to tritium in groundwater from recent and historical releases in and near Los Alamos Canyon, this section briefly summarizes the present status of knowledge found in the LANL annual environmental reports.

In the past, Los Alamos Canyon received treated and untreated industrial effluents containing some radionuclides. In the upper reach of Los Alamos Canyon there were releases of treated and untreated radioactive effluents during the earliest Manhattan Project operations at TA–1 (late 1940's) and some release of water and radionuclides from the research reactors at TA–2. Los Alamos Canyon also received discharges containing radionuclides from the sanitary sewage lagoon system at LANSCE (formerly Los Alamos Meson Physics Facility) (TA–53). The low-level radioactive waste stream was separated from the sanitary system at TA–53 in 1989 and directed into a total retention evaporation lagoon. An industrial liquid waste treatment plan that served the old plutonium processing facility at TA–21 discharged effluent containing radionuclides into DP Canyon, a tributary to Los Alamos Canyon, from 1952 to 1986.

The reach of Los Alamos Canyon within the LANL boundary currently carries flow from the Los Alamos Reservoir (west of LANL), as well

as National Pollutant Discharge Elimination System (NPDES)-permitted effluents from TA-2, TA-53, and TA-21. Infiltration of NPDES-permitted effluents and natural runoff from the stream channel maintains a shallow body of groundwater in the alluvium of Los Alamos Canyon within the LANL boundary west of State Road 4. Groundwater levels are highest in late spring from snowmelt runoff and in late summer from thundershowers. Water levels decline during the winter and early summer when runoff is at a minimum. Depth to water is typically in the range of 4 feet to 15 feet (1.2 meters to 4.6 meters). Alluvial perched groundwater also occurs in the lower portion of Los Alamos Canyon on Pueblo of San Ildefonso lands. This alluvium is not continuous with the alluvium within LANL boundaries, and can be sampled utilizing wells installed by the Bureau of Indian Affairs.

The EPA primary drinking water standard and the New Mexico livestock watering standard are both 20,000 picocuries per liter. No tritium has been detected in surface or groundwater samples using the EPA-specified method with a detection limit of 700 picocuries per liter. LANL reported a sample of surface water with 200 picocuries per liter in 1995, and samples ranging from 78 to 428 picocuries per liter in 1994. Intermediate groundwater in 1994 and 1995 had a concentration of only 27 picocuries per liter. However, these values may be meaningless, in that the past detection limit may actually be 800 to as much as 2,000 picocuries per liter, as discussed in section 5 of the 1995 annual environmental surveillance report (LANL 1996b). In any event, the tritium concentrations are well below the standards for drinking water. Tritium content of sediments could not be measured due to insufficient moisture content.

Special study samples analyzed by Miami University with a detection limit of 0.3 picocuries per liter have demonstrated minimal recharge of the regional aquifer by surface waters. Details of special and routine

measurements of tritium are found in the 1996 environmental surveillance report (LANL 1997).

D.3.3.2 *Mortandad Canyon*

Mortandad Canyon has a small drainage area that heads at TA-3. Its drainage area currently receives inflow from natural precipitation and a number of NPDES-permitted effluents, including one from the existing Radioactive Liquid Waste Treatment Facility at TA-50. The TA-50 facility began operations in 1963. In six cases during the period from 1993 through 1995, the derived concentration guide (DCG) was exceeded for: americium-241 in 1993; americium-241 and plutonium-238 in 1994; and plutonium-238, plutonium-239, plutonium-240, and americium-241 in 1995. For each of these years, the effluent nitrate concentrations exceeded the New Mexico groundwater standard of 10 milligrams per liter (nitrate as nitrogen). The groundwater standard applies because the TA-50 effluent infiltrates the alluvium in the canyon. In order to address these problems, LANL is working to upgrade the TA-50 treatment process. These effluents infiltrate the stream channel and maintain a saturated zone in the alluvium extending about 2.2 miles (3.5 kilometers) downstream from the TA-50 NPDES-permitted outfall. The easternmost extent of saturation is on site, about 1 mile (1.6 kilometers) west of the LANL boundary with the Pueblo of San Ildefonso. Surface flow in the drainage has not reached the Pueblo since observations began in the early 1960's.

Radioanalytical results for sediments collected from Mortandad Canyon in 1996 were modeled using the RESRAD model, version 5.61 (LANL 1997). The pathways evaluated are the external gamma pathway from radioactive material deposited in the sediments, the inhalation pathway from materials resuspended by winds, and the soil ingestion pathway. Because water in the canyon is not used for drinking water or

irrigation, and there are no cattle grazing in the canyon or gardens in the canyon, the drinking water, meat ingestion, and fruit/vegetable ingestion pathways were not considered.

The RESRAD model was run for each sampled location and for the entire canyon system, with 10 to 14 samples per analyte collected throughout the canyon. For modeling purposes, it is assumed that the area of interest around each monitored location is 1,076 square feet (100 square meters). The site is part of an industrial complex where access to the monitored location is somewhat limited; thus, the amount of time a person spends in the canyon is limited to approximately 87 hours per year (Robinson and Thomas 1991), and there is no cover material over the site of interest that would reduce external exposure to radionuclides. The input parameters for the RESRAD model are summarized in LANL

1997. RESRAD calculates the daughter radionuclides based on the initial radionuclide concentration and time since placement of material.

The TEDE (i.e., the sum of the effective dose equivalents from the external gamma, and the inhalation and soil ingestion pathways) is presented in Table D.3.3.2–1. For comparison, the 1995 TEDE for each monitoring location is shown also. The TEDE, using the average concentration of all monitoring locations in Mortandad Canyon, is 6.0 millirem. The error term associated with this average value is extremely large, reflecting the high degree of variability in the concentrations throughout the canyon. In 1996, the average TEDE plus twice the error term (Table D.3.3.2–1) ranged from 0.19 millirem near the Chemistry and Metallurgy Research (CMR) Building to 27 millirem at the GS–1 sampling location.

TABLE D.3.3.2–1.—Total Effective Dose Equivalent^a for Mortandad Canyon (mrem)

LOCATION	1996		1995	
Near CMR Building	0.16	(± 0.032) ^b	0.10	(± 0.14) ^b
West of GS–1	3.3	(± 0.60) ^b	0.17	(± 0.081) ^b
GS–1	24	(± 3.4) ^b	37	(± 5.9) ^b
MCO–5	21	(± 3.2) ^b	19	(± 3.3) ^b
MCO–7	8.8	(± 1.4) ^b	4.3	(± 0.95) ^b
MCO–9	0.78	(± 0.21) ^b	0.62	(± 0.20) ^b
MCO–13 (A–5)	0.65	(± 0.19) ^b	0.43	(± 1.1) ^b
A–6	0.41	(± 0.097) ^b	0.79	(± 1.2) ^b
A–7	0.36	(± 0.072) ^b	0.19	(± 0.10) ^b
A–8	— ^c		0.30	(± 0.15) ^b
SR–4 (A–9)	0.19	(± 0.057) ^b	0.17	(± 0.088) ^b
A–10	— ^c		0.061	(± 0.028) ^b
Rio Grande (A–11)	0.16	(± 0.12) ^b	0.10	(± 0.054) ^b
Average for Entire Mortandad Canyon	6.0	(± 22) ^b	6.8	(± 0.30) ^b

^a Based on results from RESRAD (version 5.61) using three exposure pathways: ingestion, inhalation, and external.

^b ±2 sigma in parenthesis

^c No sample collected at these locations in 1996.

The maximum TEDE for monitoring sites surrounding the GS-1 site (i.e., west of GS-1, MCO-5, MCO-7, and MCO-9) increased in 1996 over the 1995 values. These five monitoring locations represent 96 percent of the 1996 maximum TEDE for the entire canyon system. The only radionuclide that contributed more than 5 percent to the TEDE at these locations is cesium-137 for each of the five sites. For the other monitoring locations (i.e., near the CMR Building, MCO-13 [A-5], A-6, A-7, A-9, and A-11), the naturally occurring radionuclides of uranium, and strontium-90 and cesium-137 from nuclear atmospheric testing contributed more than 5 percent to the TEDE at these monitoring locations. Averaged over the

entire canyon system, cesium-137 and americium-241 contributed more than 5 percent to the canyon TEDE. The external pathway contributed more than 88 percent (with the cesium-137 contribution being more than 86 percent) to the total TEDE for the entire canyon system. Because there is a pathway approximately 10 feet (3 meters) from the stream channel and the external component falls off with distance from the source, the estimated TEDE is reduced to approximately 6 millirem in a year (i.e., 2.7 millirem from the external pathway and 3.3 millirem from all other pathways considered).

TABLE D.3.3-1.—Ingestion of Radioactive Isotopes from LANL Supply Wells for an Off-Site Los Alamos County Resident (From ESR 1991–1996 Data, see Table D.3.5-2)

ANALYTE	95% UCL (pCi/L)	DOSE CONVERSION FACTOR (rem/pCi)	AVERAGE- CASE DOSE (rem/year)	WORST-CASE DOSE (rem/year)
Americium-241	9.31E-02	4.50E-06	2.30E-04	3.73E-04
Cesium-137 ¹	2.30E+00	5.00E-08	6.33E-05	1.02E-04
Plutonium-238	2.40E-02	3.80E-06	5.02E-05	8.13E-05
Plutonium-239 and Plutonium-240	2.39E-01	4.30E-06	5.65E-04	9.16E-04
Strontium-90	4.48E+00	1.30E-07	3.20E-04	5.19E-04
Tritium	8.44E+02	6.30E-11	2.92E-05	4.74E-05
Uranium ²	1.29E+00	2.60E-07	1.85E-04	2.99E-04
			Average-Case	Worst-Case
Total Dose (rem/yr)			1.44E-03	2.34E-03
Cancer Risk yr⁻¹			7.22E-07	1.17E-06
¹ Cesium-137 from ESR 1992–1996 data (see text).				
² Uranium was converted using the formula from Fresquez et al. 1996, Appendix B, pg. 36 (see below).				
Average-Case Consumption				
	5.50E+02 L/yr	=number of liters per year		
Worst-Case Consumption				
	8.91E+02 L/yr	=number of liters per year		
	1 yr	=exposure duration		
Uranium Conversion:		U=	1.82	µg/L
pCi U isotope / L water = µg total Uranium/L water X RMA X SA X CF				
RMA = relative mass abundance (g isotope per g total U)				
SA = specific activity (pCi/g)				
CF = conversion factor (1E-06 g/µg)				
		RMA	SA	
U-238 =	6.05E-01 pCi/L	0.9928	3.35E+05	
U-235 =	2.83E-02 pCi/L	0.0072	2.16E+06	
U-234 =	6.59E-01 pCi/L	0.000058	6.24E+09	
Total U Activity =	1.29E+00 pCi/L			

TABLE D.3.3-2.—Ingestion of Metals in LANL Supply Wells to Off-Site Los Alamos County Residents
(From ESR 1991–1996 Data, see Table D.3.5-2)

ANALYTES	95% UCL (µg/L)	AVERAGE- CASE CHRONIC DAILY INTAKE mg/kg-day	WORST- CASE CHRONIC DAILY INTAKE mg/kg-day	ORAL RfD mg/kg-day	ORAL SLOPE FACTOR per (mg/kg)/day	AVERAGE- CASE HAZARD INDEX	WORST- CASE HAZARD INDEX	AVERAGE- CASE CANCER RISK	WORST- CASE CANCER RISK
AG	8.20E+01	1.72E-03	2.79E-03	5.0E-03	-	3.44E-01	5.58E-01		
AL	2.97E+02	6.23E-03	1.01E-02	1.8E-01	-	3.46E-02	5.61E-02		
AS ¹	4.00E+01	8.39E-04	1.36E-03	3.0E-04	1.5E+00	2.80E+00	4.53E+00	1.26E-03	2.04E-03
B	2.01E+02	4.22E-03	6.83E-03	9.0E-02	-	4.69E-02	7.59E-02		
BA	8.35E+01	1.75E-03	2.84E-03	7.0E-02	-	2.50E-02	4.06E-02		
BE ²	2.50E+00	5.25E-05	8.50E-05	5.0E-03	4.3E+00	1.05E-02	1.70E-02	2.26E-04	3.65E-04
CD	7.93E+00	1.66E-04	2.70E-04	5.0E-04	1.8E-03	3.33E-01	5.39E-01	3.00E-07	4.85E-07
CN *	1.00E+01	2.10E-04	3.40E-04	2.0E-02	-	1.05E-02	1.70E-02		
CO	2.46E+02	5.16E-03	8.36E-03	6.0E-02	-	8.60E-02	1.39E-01		
CR	1.87E+01	3.92E-04	6.36E-04	1.0E+00	-	3.92E-04	6.36E-04		
CU	3.33E+01	6.99E-04	1.13E-03	1.9E-02	-	3.68E-02	5.96E-02		
HG	2.70E-01	5.67E-06	9.18E-06	3.0E-04	-	1.89E-02	3.06E-02		
LI *	4.58E+01	9.61E-04	1.56E-03	2.0E-02	-	4.81E-02	7.79E-02		
MN	4.91E+01	1.03E-03	1.67E-03	1.4E-01	-	7.36E-03	1.19E-02		
MO	1.81E+01	3.80E-04	6.15E-04	5.0E-03	-	7.60E-02	1.23E-01		
NI	2.66E+01	5.58E-04	9.04E-04	2.0E-02	-	2.79E-02	4.52E-02		
NO3-N *	3.47E+03	7.28E-02	1.18E-01	1.6E+00	-	4.55E-02	7.37E-02		
PB ³	6.40E+01	1.34E-03	2.18E-03	1.4E-03	no data	9.59E-01	1.55E+00		
SB	3.45E+00	7.24E-05	1.17E-04	4.0E-04	-	1.81E-01	2.93E-01		
SE	3.03E+00	6.36E-05	1.03E-04	5.0E-03	-	1.27E-02	2.06E-02		
SN	3.85E+01	8.08E-04	1.31E-03	6.0E-01	-	1.35E-03	2.18E-03		
SR	1.52E+02	3.19E-03	5.17E-03	6.0E-01	-	5.32E-03	8.61E-03		

**TABLE D.3.3-2.—Ingestion of Metals in LANL Supply Wells to Off-Site Los Alamos County Residents
(From ESR 1991–1996 Data, see Table D.3.5-2)-Continued**

ANALYTES	95% UCL	AVERAGE-	WORST-	ORAL SLOPE FACTOR per (mg/kg)/day	AVERAGE-	WORST-	AVERAGE-	WORST-
	(µg/L)	CHRONIC DAILY INTAKE mg/kg-day	CHRONIC DAILY INTAKE mg/kg-day		CHRONIC DAILY INTAKE mg/kg-day	ORAL RD mg/kg-day	HAZARD INDEX	HAZARD INDEX
TI	1.00E+01	2.10E-04	3.40E-04	-	-	-	6.93E+00	1.12E+01
TL ⁴	2.64E+01	5.54E-04	8.98E-04	8.0E-05	-	-	1.27E-02	2.06E-02
U	1.82E+00	3.82E-05	6.19E-05	3.0E-03	no data	-	2.66E-01	4.31E-01
V	1.14E+02	2.39E-03	3.88E-03	9.0E-03	-	-	3.45E-03	5.59E-03
ZN	4.93E+01	1.03E-03	1.68E-03	3.0E-01	-	-	-	-

¹ Arsenic concentrations ranged from 2 to 48 µg/L in 33 of 56 samples analyzed with a mean of 12.4 µg/L for detected values.
² Beryllium concentrations ranged from 1 to 2 µg/L in 5 of 56 samples analyzed with a mean of 1.4 µg/L for detected values.
³ Lead concentrations ranged from 1 to 95 µg/L in 17 of 59 samples with a mean of 14.6 µg/L for detected values
⁴ Thallium concentrations ranged from 0.3 to 19 µg/L in 4 of 56 samples analyzed with a mean of 9.83 µg/L for detected values.

Note: gray shaded cells in UCL column have no 95% UCL - maximum value used.

Note: gray shaded cells in Slope Factor column have no known human chemical cancer risk.

Note: gray shaded cells in Carcinogenic Risk columns have no known human chemical cancer risk.

**TABLE D.3.3-2.—Ingestion of Metals in LANL Supply Wells to Off-Site Los Alamos County Residents
(From ESR 1991–1996 Data, see Table D.3.5-2)-Continued**

Groundwater Ingestion Factors

Intake (mg/kg-day) = (CW x IR x EF x ED x CF)/(BW x AT)

Note: modified from 1989, exhibit 6-12, pg. 6-36.

Value	Units	Parameter
e.g., B3	µg/L	CW = LANL Supply Well concentration
1.51E+00	L/day	IR = Average-Case ingestion rate
365	days/yr	EF = Average-Case exposure frequency
2.44E+00	L/day	IR = Worst-Case ingestion rate
365	days/yr	EF = Worst-Case exposure frequency
75	yr	ED = Exposure duration
1.00E-03	mg/µg	CF = Conversion factor
71.8	kg	BW = Body weight
27375	d	AT = ED* 365 days

Note: 550 liters per year yields 1.51 liters per day for Average-Case.

Note: 891 liters per year yields 2.44 liters per day for Worst-Case.

TABLE D.3.3-3.—Ingestion of Radioactive Isotopes from Supply Well LA-5 for an Off-Site Totavi Resident (From ESR 1991–1996 Data, see Table D.3.5-3)

ANALYTE	95% UCL (pCi/L)	DOSE CONVERSION FACTOR (rem/pCi)	AVERAGE- CASE DOSE (rem/year)	WORST-CASE DOSE (rem/year)
Americium-241	3.37E-02	4.50E-06	8.34E-05	1.35E-04
Cesium-137 ¹	1.70E+00	5.00E-08	4.68E-05	7.57E-05
Plutonium-238	6.49E-02	3.80E-06	1.36E-04	2.20E-04
Plutonium-239 and Plutonium-240	4.69E-02	4.30E-06	1.11E-04	1.80E-04
Strontium-90	8.44E-01	1.30E-07	6.03E-05	9.78E-05
Tritium	2.91E+02	6.30E-11	1.01E-05	1.63E-05
Uranium ²	9.09E-01	2.60E-07	1.30E-04	2.11E-04
			Average-Case	Worst-Case
Total Dose (rem/yr)			5.77E-04	9.35E-04
Cancer Risk yr⁻¹			2.89E-07	4.67E-07
¹ Cesium-137 was detected in 1991 (LANL 1993) and 1993 (LANL 1995). However, due to concerns with the 1991 - 1992 data (see text), only the 1993 sample is used.				
² Uranium was converted using the formula from Fresquez et al. 1996, Appendix B, pg. 36 (see below).				
Average-Case Consumption				
5.50E+02 L/yr		=number of liters per year		
Worst-Case Consumption				
8.91E+02 L/yr		=number of liters per year		
1 yr		=exposure duration		
Uranium Conversion:		U=	1.28	µg/L
pCi U isotope / L water = µg total Uranium/L water X RMA X SA X CF				
RMA = relative mass abundance (g isotope per g total U)				
SA = specific activity (pCi/g)				
CF = conversion factor (1E-06 g/µg)				
		RMA	SA	
U-238 =	4.26E-01 pCi/L	0.9928	3.35E+05	
U-235 =	1.99E-02 pCi/L	0.0072	2.16E+06	
U-234 =	4.63E-01 pCi/L	0.000058	6.24E+09	
Total U Activity =	9.09E-01 pCi/L			

TABLE D.3.3-4.—Ingestion of Metals in Supply Well LA-5 for an Off-Site Totavi Resident
(From ESR 1991–1996 Data, see Table D.3.5-3)

ANALYTES	95% UCL (µg/L)	AVERAGE-CASE		ORAL RFD mg/kg-day	ORAL SLOPE FACTOR per (mg/kg)/day	AVERAGE-HAZARD INDEX		WORST-CASE HAZARD INDEX		WORST-CASE CANCER RISK	
		CHRONIC DAILY INTAKE mg/kg-day	CHRONIC DAILY INTAKE mg/kg-day			HAZARD INDEX	HAZARD INDEX	HAZARD INDEX	HAZARD INDEX	CANCER RISK	CANCER RISK
AL	6.20E+01	1.30E-03	2.11E-03	1.8E-01	-	7.23E-03	1.17E-02	1.17E-02	1.17E-02	1.20E-04	1.95E-04
AS ¹	3.82E+00	8.02E-05	1.30E-04	3.0E-04	1.5E+00	2.67E-01	4.33E-01	4.33E-01	4.33E-01	1.20E-04	1.95E-04
B	3.10E+01	6.51E-04	1.05E-03	9.0E-02	-	7.23E-03	1.17E-02	1.17E-02	1.17E-02	1.20E-04	1.95E-04
BA	6.84E+01	1.44E-03	2.33E-03	7.0E-02	-	2.05E-02	3.32E-02	3.32E-02	3.32E-02	1.20E-04	1.95E-04
BE	not detected			5.0E-03	4.3E+00						
CD	not detected			5.0E-04	1.8E-03						
CN *	not detected			2.0E-02	-						
CO	not detected			6.0E-02	-						
CR	3.58E+01	7.51E-04	1.22E-03	1.0E+00	-	7.51E-04	1.22E-03	1.22E-03	1.22E-03	1.20E-04	1.95E-04
CU	not detected			1.9E-02	-						
F *	not detected			6.0E-02	-						
FE	8.50E+02	1.78E-02	2.89E-02	-	-						
HG	1.00E-01	2.10E-06	3.40E-06	3.0E-04	-	7.00E-03	1.13E-02	1.13E-02	1.13E-02	1.20E-04	1.95E-04
LI *	not detected			2.0E-02	-						
MN	4.92E+01	1.03E-03	1.67E-03	1.4E-01	-	7.38E-03	1.19E-02	1.19E-02	1.19E-02	1.20E-04	1.95E-04
MO	1.70E+00	3.57E-05	5.78E-05	5.0E-03	-	7.14E-03	1.16E-02	1.16E-02	1.16E-02	1.20E-04	1.95E-04
NI	not detected			2.0E-02	-						
NO2-N *	not detected			1.0E-01	-						
NO3-N *	9.16E+02	1.92E-02	3.11E-02	1.6E+00	-	1.20E-02	1.95E-02	1.95E-02	1.95E-02	1.20E-04	1.95E-04
PB	not detected			1.4E-03	no data						
SB	3.00E-01	6.30E-06	1.02E-05	4.0E-04	-	1.57E-02	2.55E-02	2.55E-02	2.55E-02	1.20E-04	1.95E-04
SE	2.00E+00	4.20E-05	6.80E-05	5.0E-03	-	8.39E-03	1.36E-02	1.36E-02	1.36E-02	1.20E-04	1.95E-04

TABLE D.3.3-4.—Ingestion of Metals in Supply Well LA-5 for an Off-Site Totavi Resident
 (From ESR 1991-1996 Data, see Table D.3.5-3)-Continued

Groundwater Ingestion Factors

Intake (mg/kg-day) = (CW x IR x EF x ED x CF)/(BW x AT)

Note: modified from EPA 1989, exhibit 6-12, pg. 6-36.

Value	Units	Parameter
e-g., B3	µg/L	CW = LA-5 supply well concentration
1.51E+00	L/day	IR = Average-Case ingestion rate
365	days/yr	EF = Average-Case exposure frequency
2.44E+00	L/day	IR = Worst-Case ingestion rate
365	days/yr	EF = Worst-Case exposure frequency
75	yr	ED = Exposure duration
1.00E-03	mg/µg	CF = Conversion factor
71.8	kg	BW = Body weight
27375	d	AT = ED* 365 days

Note: 550 liters per year yields 1.51 liters per day for Average-Case.

Note: 891 liters per year yields 2.44 liters per day for Worst-Case.

TABLE D.3.3-5.—Ingestion of Radioactive Isotopes from San Ildefonso Supply Wells for an Off-Site Non-Los Alamos County Resident
(From ESR 1991–1996 Data, see Table C-6 but without LA-5 Well)

ANALYTE	95% UCL (pCi/L)	DOSE CONVERSION FACTOR (rem/pCi)	AVERAGE- CASE DOSE (rem/year)	WORST-CASE DOSE (rem/year)
Americium-241	6.10E-02	4.50E-06	1.51E-04	2.45E-04
Cesium-137 ¹	3.56E+00	5.00E-08	9.79E-05	1.59E-04
Plutonium-238	8.69E-02	3.80E-06	1.82E-04	2.94E-04
Plutonium-239 and Plutonium-240	1.47E-01	4.30E-06	3.48E-04	5.63E-04
Strontium-90	3.84E+00	1.30E-07	2.75E-04	4.45E-04
Tritium	1.13E+03	6.30E-11	3.92E-05	6.34E-05
Uranium ²	2.14E+01	2.60E-07	3.07E-03	4.97E-03
			Average-Case	Worst-Case
Total Dose (rem/yr)			4.16E-03	6.74E-03
Cancer Risk yr⁻¹			2.08E-06	3.37E-06
¹ Cesium-137 from ESR 1992–1996 (see text).				
² Uranium was converted using the formula from Fresquez et al. 1996, Appendix B, pg. 36 (see below).				
Average-Case Consumption				
5.50E+02 L/yr		=number of liters per year		
Worst-Case Consumption				
8.91E+02 L/yr		=number of liters per year		
1 yr		=exposure duration		
Uranium Conversion:		U=	30.2	µg/L
pCi U isotope / L water = µg total Uranium/L water X RMA X SA X CF				
RMA = relative mass abundance (g isotope per g total U)				
SA = specific activity (pCi/g)				
CF = conversion factor (1E-06 g/µg)				
		RMA	SA	
U-238 =	1.00E+01 pCi/L	0.9928	3.35E+05	
U-235 =	4.70E-01 pCi/L	0.0072	2.16E+06	
U-234 =	1.09E+01 pCi/L	0.000058	6.24E+09	
Total U Activity =	2.14E+01 pCi/L			

TABLE D.3.3-6.—Ingestion of Metals in San Ildefonso Supply Wells for an Off-Site Non-Los Alamos County Resident (From ESR 1991–1996 Data, see Table C-6 But Without LA-5 Well)-Continued

ANALYTES	95% UCL (µg/L)	AVERAGE-CASE CHRONIC DAILY INTAKE		ORAL RfD mg/kg-day	ORAL SLOPE FACTOR per (mg/kg)/day	AVERAGE-CASE HAZARD INDEX		WORST-CASE HAZARD INDEX		WORST-CASE CANCER RISK
		mg/kg-day	mg/kg-day			mg/kg-day	mg/kg-day	mg/kg-day	mg/kg-day	
U	3.02E+01	6.34E-04	1.03E-03	3.0E-03	no data	2.11E-01	3.42E-01			
V	3.94E+01	8.27E-04	1.34E-03	9.0E-03	-	9.19E-02	1.49E-01			
ZN	2.76E+02	5.79E-03	9.38E-03	3.0E-01	-	1.93E-02	3.13E-02			

¹ Arsenic concentrations ranged from 2 to 41 µg/L in 44 of 48 samples analyzed with a mean of 9.07 µg/L for detected values.

² Beryllium concentrations ranged from 1 to 17 µg/L in 6 of 48 samples analyzed with a mean of 7 µg/L for detected values.

Note: gray shaded cells in UCL column have no 95% UCL - maximum value used.

Note: gray shaded cells in Slope Factor column have no known human chemical cancer risk.

Note: gray shaded cells in Carcinogenic Risk columns have no known human chemical cancer risk.

Groundwater Ingestion Factors

Intake (mg/kg-day) = (CW x IR x EF x ED x CF)/(BW x AT)

Note: modified from EPA 1989, exhibit 6-12, pg. 6-36.

Value	Units	Parameter
e.g., B3	µg/L	CW = San Ildefonso supply well concentration
1.51E+00	L/day	IR = Average-Case ingestion rate
365	days/yr	EF = Average-Case exposure frequency
2.44E+00	L/day	IR = Worst-Case ingestion rate
365	days/yr	EF = Worst-Case exposure frequency
75	yr	ED = Exposure duration
1.00E-03	mg/µg	CF = Conversion factor
71.8	kg	BW = Body weight
27375	d	AT = ED* 365 days

Note: 550 liters per year yields 1.51 liters per day for Average-Case.

Note: 891 liters per year yields 2.44 liters per day for Worst-Case.

TABLE D.3.3-7.—Ingestion of Radioactive Isotopes in Surface Water for a Resident Recreational User (From ESR 1991–1996 Data, see Table C-2)

ANALYTE	95% UCL (pCi/L)	DOSE CONVERSION FACTOR (rem/pCi)	AVERAGE-CASE DOSE (rem/year)	WORST-CASE DOSE (rem/year)
Americium-241	1.20E+00	4.50E-06	2.88E-05	4.67E-05
Cesium-137 ¹	2.49E+01	5.00E-08	6.64E-06	1.08E-05
Plutonium-238	1.10E+00	3.80E-06	2.23E-05	3.61E-05
Plutonium-239 and Plutonium-240	1.00E+01	4.30E-06	2.29E-04	3.72E-04
Strontium-90	2.40E+02	1.30E-07	1.66E-04	2.70E-04
Tritium	7.70E+00	6.30E-11	2.59E-09	4.19E-09
Uranium ²	2.41E+00	2.60E-07	3.35E-06	5.42E-06
			Average-Case	Worst-Case
Total Dose (rem/yr)			4.57E-04	7.40E-04
Cancer Risk yr⁻¹			2.28E-07	3.70E-07
¹ Cesium-137 from ESR 1993–1996 data (see text).				
² Uranium was converted using the formula from Fresquez et al. 1996, Appendix B, pg 36 (see below).				
Average-Case Consumption				
	2.78E-02 L/hr	=ingestion rate per hour		
	8 hr/event	=number of hours per visit		
	24 events/yr	=number of visits per year		
	5.33E+00 L/yr	=number of liters per year		
Worst-Case Consumption				
	4.50E-02 L/hr	=ingestion rate per hour		
	8 hr/event	=number of hours per visit		
	24 events/yr	=number of visits per year		
	8.64E+00 L/yr	=number of liters per year		
	1 yr	=exposure duration		

Note: 0.5 liters per day over 18 hrs yields 2.78E-02 L/hr for Average-Case.

Note: Average case increased by 1.62 yields 4.5E-02 L/hr for Worst-Case.

Uranium Conversion:	U=	3.4	µg/L
pCi U isotope / L water = µg total Uranium/L water X RMA X SA X CF			
RMA = relative mass abundance (g isotope per g total U)			
SA = specific activity (pCi/g)			
CF = conversion factor (1E-06 g/µg)			
		RMA	SA
U-238 =	1.13E+00 pCi/L	0.9928	3.35E+05
U-235 =	5.29E-02 pCi/L	0.0072	2.16E+06
U-234 =	1.23E+00 pCi/L	0.000058	6.24E+09
Total U Activity =	2.41E+00 pCi/L		

TABLE D.3.3-8.—Ingestion of Metals in Surface Water to Resident Recreational User
(From ESR 1991–1996 Data, see Table C-2)

ANALYTES	95% UCL (µg/L)	AVERAGE- CASE		WORST- CASE		ORAL SLOPE FACTOR per mg/kg/day	AVERAGE- CASE		WORST- CASE		AVERAGE- CASE		WORST- CASE	
		CHRONIC DAILY INTAKE mg/kg-day	CHRONIC DAILY INTAKE mg/kg-day	CHRONIC DAILY INTAKE mg/kg-day	CHRONIC DAILY INTAKE mg/kg-day		HAZARD INDEX	HAZARD INDEX	HAZARD INDEX	HAZARD INDEX	HAZARD INDEX	HAZARD INDEX	CANCER RISK	CANCER RISK
AG	3.50E+02	7.12E-05	1.15E-04	5.0E-03	-	1.42E-02	2.31E-02							
AL	2.40E+04	4.88E-03	7.91E-03	1.8E-01	-	2.71E-02	4.40E-02							
AS	1.00E+01	2.04E-06	3.30E-06	3.0E-04	1.5E+00	6.78E-03	1.10E-02	3.05E-06	4.95E-06					
B	2.50E+02	5.09E-05	8.24E-05	9.0E-02	-	5.65E-04	9.16E-04							
BA	4.70E+02	9.56E-05	1.55E-04	7.0E-02	-	1.37E-03	2.21E-03							
BE	8.40E+01	1.71E-05	2.77E-05	5.0E-03	4.3E+00	3.42E-03	5.54E-03	7.35E-05	1.19E-04					
CD	1.30E+02	2.65E-05	4.29E-05	5.0E-04	1.8E-03	5.29E-02	8.57E-02	4.76E-08	7.71E-08					
CN *	7.90E+01	1.61E-05	2.60E-05	2.0E-02	-	8.04E-04	1.30E-03							
CO	1.10E+02	2.24E-05	3.63E-05	6.0E-02	-	3.73E-04	6.04E-04							
CR	2.80E+02	5.70E-05	9.23E-05	1.0E+00	-	5.70E-05	9.23E-05							
CU	2.80E+02	5.70E-05	9.23E-05	1.9E-02	-	3.00E-03	4.86E-03							
F *	1.80E+03	3.66E-04	5.93E-04	6.0E-02	-	6.11E-03	9.89E-03							
FE	2.00E+04	4.07E-03	6.59E-03	-	-	-	-							
HG	7.40E-01	1.51E-07	2.44E-07	3.0E-04	-	5.02E-04	8.13E-04							
LI *	6.40E+01	1.30E-05	2.11E-05	2.0E-02	-	6.51E-04	1.05E-03							
MN	8.20E+02	1.67E-04	2.70E-04	1.4E-01	-	1.19E-03	1.93E-03							
MO	8.60E+02	1.75E-04	2.84E-04	5.0E-03	-	3.50E-02	5.67E-02							
NI	6.80E+02	1.38E-04	2.24E-04	2.0E-02	-	6.92E-03	1.12E-02							
NO2-N *	4.60E+02	9.36E-05	1.52E-04	1.0E-01	-	9.36E-04	1.52E-03							
NO3-N *	1.40E+04	2.85E-03	4.62E-03	1.6E+00	-	1.78E-03	2.88E-03							
PB	2.80E+01	5.70E-06	9.23E-06	1.4E-03	no data	4.07E-03	6.59E-03							
SB	2.50E+00	5.09E-07	8.24E-07	4.0E-04	-	1.27E-03	2.06E-03							

TABLE D.3.3-8.—Ingestion of Metals in Surface Water to Resident Recreational User
(From ESR 1991-1996 Data, see Table C-2)-Continued

ANALYTES	95% UCL (µg/L)	AVERAGE- CASE CHRONIC DAILY INTAKE mg/kg-day	WORST- CASE CHRONIC DAILY INTAKE mg/kg-day	ORAL RfD mg/kg-day	ORAL SLOPE FACTOR per mg/kg/ day	AVERAGE- CASE HAZARD INDEX	WORST- CASE HAZARD INDEX	AVERAGE- CASE CANCER RISK	WORST- CASE CANCER RISK
SE	4.50E+02	9.16E-05	1.48E-04	5.0E-03	-	1.83E-02	2.97E-02		
SN	1.90E+02	3.87E-05	6.26E-05	6.0E-01	-	6.44E-05	1.04E-04		
SO4 *	9.30E+04	1.89E-02	3.07E-02		-				
SR	3.90E+02	7.94E-05	1.29E-04	6.0E-01	-	1.32E-04	2.14E-04		
TL	4.30E+00	8.75E-07	1.42E-06	8.0E-05	-	1.09E-02	1.77E-02		
U	3.40E+00	6.92E-07	1.12E-06	3.0E-03	no data	2.31E-04	3.74E-04		
V	6.00E+01	1.22E-05	1.98E-05	9.0E-03	-	1.36E-03	2.20E-03		
ZN	2.20E+02	4.48E-05	7.25E-05	3.0E-01	-	1.49E-04	2.42E-04		
Acetone	6.10E+01	1.24E-05	2.01E-05	1.0E-01	-	1.24E-04	2.01E-04		
Benzoic acid	1.10E+01	2.24E-06	3.63E-06	4.0E+00	-	5.60E-07	9.07E-07		
Bis(2-ethylhexyl) phthalate	1.90E+01	3.87E-06	6.26E-06	2.0E-02	1.4E-02	1.93E-04	3.13E-04	5.41E-08	8.77E-08
Di-n-butyl phthalate	1.80E+01	3.66E-06	5.93E-06	1.0E-01	-	3.66E-05	5.93E-05		
Di-n-octyl phthalate	8.00E+00	1.63E-06	2.64E-06	2.0E-02	-	8.14E-05	1.32E-04		
HMX	4.90E+00	9.97E-07	1.62E-06	5.0E-02	-	1.99E-05	3.23E-05		
RDX	7.60E-01	1.55E-07	2.51E-07	3.0E-03	1.1E-01	5.16E-05	8.35E-05	1.70E-08	2.76E-08

Note: gray shaded cells in UCL column have no 95% UCL - maximum value used.

Note: gray shaded cells in Slope Factor column have no known human chemical cancer risk.

Note: gray shaded cells in Carcinogenic Risk columns have no known human chemical cancer risk.

TABLE D.3.3-8.—Ingestion of Metals in Surface Water to Resident Recreational User
 (From ESR 1991–1996 Data, see Table C-2)-Continued

Surface Water Ingestion Factors - Resident Recreational User

Intake (mg/kg/day) = (CW x IR x ET x EF x ED x CF)/(BW x AT)

Note: modified from EPA 1989, exhibit 6-12, pg. 6-36.

Value	Units	Parameter
e.g., B3	µg/L	CW = On-site concentration
2.78E-02	L/hr	IR = Average-Case ingestion rate (0.5 L / 18 hours)
8	hr/event	ET = Average-Case exposure time
24	events/yr	EF = Average-Case exposure frequency
4.50E-02	L/hr	IR = Worst-Case ingestion rate (0.5 L * 1.62 / 18 hours)
8	hr/event	ET = Worst-Case exposure time
24	events/yr	EF = Worst-Case exposure frequency
75	yr	ED = Exposure duration
1.00E-03	mg/µg	CF = Conversion factor
71.8	kg	BW = Body weight
27375	d	AT = ED* 365 days

TABLE D.3.3-9.—Ingestion of Radioactive Isotopes in Surface Water for a Nonresident Recreational User (From ESR 1991–1996 Data, see Table C-2)

ANALYTE	95% UCL (pCi/L)	DOSE CONVERSION FACTOR (rem/pCi)	AVERAGE-CASE DOSE (rem/year)	WORST-CASE DOSE (rem/year)
Americium-241	1.20E+00	4.50E-06	1.08E-05	1.75E-05
Cesium-137 ¹	2.49E+01	5.00E-08	2.49E-06	4.03E-06
Plutonium-238	1.10E+00	3.80E-06	8.36E-06	1.35E-05
Plutonium-239 and Plutonium-240	1.00E+01	4.30E-06	8.60E-05	1.39E-04
Strontium-90	2.40E+02	1.30E-07	6.24E-05	1.01E-04
Tritium	7.70E+00	6.30E-11	9.70E-10	1.57E-09
Uranium ²	2.41E+00	2.60E-07	1.26E-06	2.03E-06
			Average-Case	Worst-Case
Total Dose (rem/yr)			1.71E-04	2.78E-04
Cancer Risk yr⁻¹			8.57E-08	1.39E-07
¹ Cesium-137 from ESR 1993–1996 data (see text).				
² Uranium was converted using the formula from Fresquez et al. 1996, Appendix B, pg. 36 (see below).				
Average-Case Consumption				
	2.78E-02 L/hr	=ingestion rate per hour		
	6 hr/event	=number of hours per visit		
	12 events/yr	=number of visits per year		
	2.00E+00 L/yr	=number of liters per year		
Worst-Case Consumption				
	4.50E-02 L/hr	=ingestion rate per hour		
	6 hr/event	=number of hours per visit		
	12 events/yr	=number of visits per year		
	3.24E+00 L/yr	=number of liters per year		
	1 yr	=exposure duration		

Note: 0.5 liters per day over 18 hrs yields 2.78E-02 L/hr for Average-Case.

Note: Average case increased by 1.62 yields 4.5E-02 L/hr for Worst-Case.

Uranium Conversion:	U=	3.4	µg/L
pCi U isotope / L water = µg total Uranium/L water X RMA X SA X CF			
RMA = relative mass abundance (g isotope per g total U)			
SA = specific activity (pCi/g)			
CF = conversion factor (1E-06 g/µg)			
		RMA	SA
U-238 =	1.13E+00 pCi/L	0.9928	3.35E+05
U-235 =	5.29E-02 pCi/L	0.0072	2.16E+06
U-234 =	1.23E+00 pCi/L	0.000058	6.24E+09
Total U Activity =	2.41E+00 pCi/L		

TABLE D.3.3-10.—Ingestion of Metals in Surface Water for a Nonresident Recreational User
(From ESR 1991-1996 Data, see Table C-2)

ANALYTES	95% UCL (µg/L)	AVERAGE- CASE CHRONIC DAILY INTAKE mg/kg-day	WORST- CASE CHRONIC DAILY INTAKE mg/kg-day	ORAL RfD mg/kg-day	ORAL SLOPE FACTOR per mg/kg/day	AVERAGE- CASE HAZARD INDEX	WORST- CASE HAZARD INDEX	AVERAGE- CASE CANCER RISK	WORST- CASE CANCER RISK
AG	3.50E+02	2.67E-05	4.33E-05	5.0E-03	-	5.34E-03	8.65E-03		
AL	2.40E+04	1.83E-03	2.97E-03	1.8E-01	-	1.02E-02	1.65E-02		
AS	1.00E+01	7.63E-07	1.24E-06	3.0E-04	1.5E+00	2.54E-03	4.12E-03	1.14E-06	1.85E-06
B	2.50E+02	1.91E-05	3.09E-05	9.0E-02	-	2.12E-04	3.43E-04		
BA	4.70E+02	3.59E-05	5.81E-05	7.0E-02	-	5.12E-04	8.30E-04		
BE	8.40E+01	6.41E-06	1.04E-05	5.0E-03	4.3E+00	1.28E-03	2.08E-03	2.76E-05	4.47E-05
CD	1.30E+02	9.92E-06	1.61E-05	5.0E-04	1.8E-03	1.98E-02	3.21E-02	1.79E-08	2.89E-08
CN *	7.90E+01	6.03E-06	9.77E-06	2.0E-02	-	3.01E-04	4.88E-04		
CO	1.10E+02	8.39E-06	1.36E-05	6.0E-02	-	1.40E-04	2.27E-04		
CR	2.80E+02	2.14E-05	3.46E-05	1.0E+00	-	2.14E-05	3.46E-05		
CU	2.80E+02	2.14E-05	3.46E-05	1.9E-02	-	1.12E-03	1.82E-03		
F *	1.80E+03	1.37E-04	2.23E-04	6.0E-02	-	2.29E-03	3.71E-03		
FE	2.00E+04	1.53E-03	2.47E-03	-	-				
HG	7.40E-01	5.65E-08	9.15E-08	3.0E-04	-	1.88E-04	3.05E-04		
LI *	6.40E+01	4.88E-06	7.91E-06	2.0E-02	-	2.44E-04	3.96E-04		
MN	8.20E+02	6.26E-05	1.01E-04	1.4E-01	-	4.47E-04	7.24E-04		
MO	8.60E+02	6.56E-05	1.06E-04	5.0E-03	-	1.31E-02	2.13E-02		
NI	6.80E+02	5.19E-05	8.41E-05	2.0E-02	-	2.59E-03	4.20E-03		
NO2-N *	4.60E+02	3.51E-05	5.69E-05	1.0E-01	-	3.51E-04	5.69E-04		
NO3-N *	1.40E+04	1.07E-03	1.73E-03	1.6E+00	-	6.68E-04	1.08E-03		
PB	2.80E+01	2.14E-06	3.46E-06	1.4E-03	no data	1.53E-03	2.47E-03		

TABLE D.3.3-10.—Ingestion of Metals in Surface Water for a Nonresident Recreational User
(From ESR 1991-1996 Data, see Table C-2)-Continued

ANALYTES	95% UCL (µg/L)	AVERAGE- CASE CHRONIC DAILY INTAKE mg/kg-day	WORST- CASE CHRONIC DAILY INTAKE mg/kg-day	ORAL SLOPE FACTOR per mg/kg/day	AVERAGE- CASE HAZARD INDEX	WORST- CASE HAZARD INDEX	AVERAGE- CASE CANCER RISK	WORST- CASE CANCER RISK
SB	2.50E+00	1.91E-07	3.09E-07	-	4.77E-04	7.73E-04		
SE	4.50E+02	3.43E-05	5.56E-05	-	6.87E-03	1.11E-02		
SN	1.90E+02	1.45E-05	2.35E-05	-	2.42E-05	3.91E-05		
SR	3.90E+02	2.98E-05	4.82E-05	-	4.96E-05	8.04E-05		
TL	4.30E+00	3.28E-07	5.32E-07	-	4.10E-03	6.65E-03		
U	3.40E+00	2.59E-07	4.20E-07	no data	8.65E-05	1.40E-04		
V	6.00E+01	4.58E-06	7.42E-06	-	5.09E-04	8.24E-04		
ZN	2.20E+02	1.68E-05	2.72E-05	-	5.60E-05	9.07E-05		
Acetone	6.10E+01	4.66E-06	7.54E-06	-	4.66E-05	7.54E-05		
Benzoic acid	1.10E+01	8.39E-07	1.36E-06	-	2.10E-07	3.40E-07		
Bis(2-ethylhexyl) phthalate	1.90E+01	1.45E-06	2.35E-06	1.4E-02	7.25E-05	1.17E-04	2.03E-08	3.29E-08
Di-n-butyl phthalate	1.80E+01	1.37E-06	2.23E-06	-	1.37E-05	2.23E-05		
Di-n-octyl phthalate	8.00E+00	6.11E-07	9.89E-07	-	3.05E-05	4.95E-05		
HMX	4.90E+00	3.74E-07	6.06E-07	-	7.48E-06	1.21E-05		
RDX	7.60E-01	5.80E-08	9.40E-08	1.1E-01	1.93E-05	3.13E-05	6.38E-09	1.03E-08

Note: gray shaded cells in UCL column have no 95% UCL - maximum value used.

Note: gray shaded cells in Slope Factor column have no known human chemical cancer risk.

Note: gray shaded cells in Carcinogenic Risk columns have no known human chemical cancer risk.

**TABLE D.3.3-10.—Ingestion of Metals in Surface Water for a Nonresident Recreational User
(From ESR 1991-1996 Data, see Table C-2)-Continued**

Surface Water Ingestion Factors - Nonresident Recreational User

Intake (mg/kg/day) = (CW x IR x ET x EF x ED x CF)/(BW x AT)

Note: modified from EPA 1989, exhibit 6-12, pg. 6-36.

Value	Units	Parameter
e.g., B3	µg/L	CW = On-site concentration
2.78E-02	L/hr	IR = Average-Case ingestion rate (0.5 L / 18 hours)
6	hr/event	ET = Average-Case exposure time
12	events/yr	EF = Average-Case exposure frequency
4.50E-02	L/hr	IR = Worst-Case ingestion rate (0.5 L * 1.62 / 18 hours)
6	hr/event	ET = Worst-Case exposure time
12	events/yr	EF = Worst-Case exposure frequency
1	yr	ED = Exposure duration
1.00E-03	mg/µg	CF = Conversion factor
71.8	kg	BW = Body weight
365	d	AT = ED* 365 days

TABLE D.3.3–11.—Ingestion of Radioactive Isotopes in NPDES Discharge Water for a Resident Recreational User (From NPDES Data, 1994–1996, see Table D.3.5–4)

ANALYTE	95% UCL (pCi/L)	DOSE CONVERSION FACTOR (rem/pCi)	AVERAGE-CASE DOSE (rem/year)	WORST-CASE DOSE (rem/year)
Tritium	3.70E+04	6.30E-11	1.24E-05	2.01E-05
Radium-226 and Radium-228	7.30E+00	1.20E-06	4.67E-05	7.57E-05
			Average-Case	Worst-Case
Total Dose (rem/yr)			5.92E-05	9.58E-05
Cancer Risk yr⁻¹			2.96E-08	4.79E-08
Average-Case Consumption				
	2.78E-02 L/hr	=ingestion rate per hour		
	8 hr/event	=number of hours per visit		
	24 events/yr	=number of visits per year		
	5.33E+00 L/yr	=number of liters per year		
Worst-Case Consumption				
	4.50E-02 L/hr	=ingestion rate per hour		
	8 hr/event	=number of hours per visit		
	24 events/yr	=number of visits per year		
	8.64E+00 L/yr	=number of liters per year		
	1 yr	=exposure duration		

Note: 0.5 liters per day over 18 hrs yields 2.78E-02 L/hr for Average-Case.

Note: Average case increased by 1.62 yields 4.5E-02 L/hr for Worst-Case.

TABLE D.3.3-12.—Ingestion of Metals in NPDES Discharge for a Resident Recreational User
 (From NPDES 1994–1996 Data, see Table D.3.5-4)

ANALYTES	95% UCL (µg/L)	AVERAGE- CASE CHRONIC DAILY INTAKE mg/kg-day	WORST- CASE CHRONIC DAILY INTAKE mg/kg-day	ORAL RfD mg/kg-day	ORAL SLOPE FACTOR per mg/kg/day	AVERAGE- CASE HAZARD INDEX	WORST- CASE HAZARD INDEX	AVERAGE- CASE CANCER RISK	WORST- CASE CANCER RISK
AL	7.50E+02	1.53E-04	2.47E-04	1.8E-01	-	8.48E-04	1.37E-03		
AS	2.60E+01	5.29E-06	8.57E-06	3.0E-04	1.5E+00	1.76E-02	2.86E-02	7.94E-06	1.29E-05
B	5.40E+02	1.10E-04	1.78E-04	9.0E-02	-	1.22E-03	1.98E-03		
CD	1.00E+01	2.04E-06	3.30E-06	5.0E-04	1.8E-03	4.07E-03	6.59E-03	3.66E-09	5.93E-09
CO	1.70E+01	3.46E-06	5.60E-06	6.0E-02	-	5.77E-05	9.34E-05		
CR	3.80E+01	7.73E-06	1.25E-05	1.0E+00	-	7.73E-06	1.25E-05		
CU	2.50E+02	5.09E-05	8.24E-05	1.9E-02	-	2.68E-03	4.34E-03		
HG	1.70E+00	3.46E-07	5.60E-07	3.0E-04	-	1.15E-03	1.87E-03		
PB	3.20E+01	6.51E-06	1.05E-05	1.4E-03	no data	4.65E-03	7.54E-03		
SE	4.60E+00	9.36E-07	1.52E-06	5.0E-03	-	1.87E-04	3.03E-04		
V	4.70E+01	9.56E-06	1.55E-05	9.0E-03	-	1.06E-03	1.72E-03		
ZN	3.40E+02	6.92E-05	1.12E-04	3.0E-01	-	2.31E-04	3.74E-04		

Note: gray shaded cells in Slope Factor column have no known human chemical cancer risk.
 Note: gray shaded cells in Carcinogenic Risk columns have no known human chemical cancer risk.

TABLE D.3.3-12.—Ingestion of Metals in NPDES Discharge for a Resident Recreational User
(From NPDES 1994–1996 Data, see Table D.3.5-4)-Continued

NPDES Discharge Ingestion Factors - Resident Recreational User

Intake (mg/kg/day) = (CW x IR x ET x EF x ED x CF)/(BW x AT)

Note: modified from EPA 1989, exhibit 6-12, pg. 6-36.

Value	Units	Parameter
e.g., B3	µg/L	CW = On-site concentration
2.78E-02	L/hr	IR = Average-Case ingestion rate (0.5 L / 18 hours)
8	hr/event	ET = Average-Case exposure time
24	events/yr	EF = Average-Case exposure frequency
4.50E-02	L/hr	IR = Worst-Case ingestion rate (0.5 L * 1.62 / 18 hours)
8	hr/event	ET = Worst-Case exposure time
24	events/yr	EF = Worst-Case exposure frequency
75	yr	ED = Exposure duration
1.00E-03	mg/µg	CF = Conversion factor
71.8	kg	BW = Body weight
27375	d	AT = ED* 365 days

TABLE D.3.3–13.—Ingestion of Radioactive Isotopes in NPDES Discharge Water for a Nonresident Recreational User (From NPDES 1994–1996 Data, see Table D.3.5–4)

ANALYTE	95% UCL (pCi/L)	DOSE CONVERSION FACTOR (rem/pCi)	AVERAGE-CASE DOSE (rem/year)	WORST-CASE DOSE (rem/year)
Tritium	3.70E+04	6.30E-11	4.66E-06	7.55E-06
Radium-226 and Radium-228	7.30E+00	1.20E-06	1.75E-05	2.84E-05
			Average-Case	Worst-Case
Total Dose (rem/yr)			2.22E-05	3.59E-05
Cancer Risk yr⁻¹			1.11E-08	1.80E-08
Average-Case Consumption				
	2.78E-02 L/hr	=ingestion rate per hour		
	6 hr/event	=number of hours per visit		
	12 events/yr	=number of visits per year		
	2.00E+00 L/yr	=number of liters per year		
Worst-Case Consumption				
	4.50E-02 L/hr	=ingestion rate per hour		
	6 hr/event	=number of hours per visit		
	12 events/yr	=number of visits per year		
	3.24E+00 L/yr	=number of liters per year		
	1 yr	=exposure duration		

Note: 0.5 liters per day over 18 hrs yields 2.78E-02 L/hr for Average-Case.

Note: Average case increased by 1.62 yields 4.5E-02 L/hr for Worst-Case.

TABLE D.3.3-14.—Ingestion of Metals in NPDES Discharge for a Nonresident Recreational User
 (From NPDES 1994–1996 Data, see Table D.3.5-4)-Continued

NPDES Discharge Ingestion Factors - Nonresident Recreational User

Intake (mg/kg/day) = (CW x IR x ET x EF x ED x CF)/(BW x AT)

Note: modified from EPA 1989, exhibit 6-12, pg. 6-36.

Value	Units	Parameter
e.g., B3	µg/L	CW = On-site concentration
2.78E-02	L/hr	IR = Average-Case ingestion rate (0.5 L / 18 hours)
6	hr/event	ET = Average-Case exposure time
12	events/yr	EF = Average-Case exposure frequency
4.50E-02	L/hr	IR = Worst-Case ingestion rate (0.5 L * 1.62 / 18 hours)
6	hr/event	ET = Worst-Case exposure time
12	events/yr	EF = Worst-Case exposure frequency
1	yr	ED = Exposure duration
1.00E-03	mg/µg	CF = Conversion factor
71.8	kg	BW = Body weight
365	d	AT = ED* 365 days

TABLE D.3.3–15.—Ingestion of Radioactive Isotopes in Perimeter Soil for an Off-Site Resident (Nonspecific County) (From ESR 1991–1996 Data, see Table D.3.5–5)

ANALYTE	95% UCL (pCi/g)	DOSE CONVERSION FACTOR (rem/pCi)	AVERAGE-CASE DOSE (rem/year)	WORST-CASE DOSE (rem/year)
Americium-241	3.70E-02	4.50E-06	6.08E-06	2.43E-05
Cesium-137	9.80E-01	5.00E-08	1.79E-06	7.15E-06
Plutonium-238	2.90E-02	3.80E-06	4.02E-06	1.61E-05
Plutonium-239 and Plutonium-240	2.13E-01	4.30E-06	3.34E-05	1.34E-04
Strontium-90	7.00E-01	1.30E-07	3.32E-06	1.33E-05
Tritium ¹	8.44E-02	6.30E-11	1.94E-10	7.77E-10
Uranium ²	3.12E+00	2.60E-07	2.96E-05	1.19E-04
			Average-Case	Worst-Case
Total Dose (rem/yr)			7.83E-05	3.13E-04
Cancer Risk yr⁻¹			3.91E-08	1.57E-07
¹ Tritium was converted from pCi/mL using the formulas from Fresquez et al. 1996, Appendix B, pg. 36 (see below).				
² Uranium was similarly converted (see below).				
Average-Case Consumption				
	1.00E+02 mg/day	=number of mg per day		
	365 days/yr	=number of days per year		
	3.65E+01 g/yr	=number of grams per year		
Worst-Case Consumption				
	4.00E+02 mg/day	=number of mg per day		
	365 days/yr	=number of days per year		
	1.46E+02 g/yr	=number of grams per year		
	1 yr	=exposure duration		
Tritium Conversion:		H³=	0.76	pCi/mL
pCi/g = pCi/mL X (fraction soil moisture/soil moisture density X [1-fraction soil moisture])				
fraction soil moisture = 10%				
soil moisture density = 1 g/mL				
Tritium Activity (pCi/g) = 8.44E-02				

TABLE D.3.3-15.—Ingestion of Radioactive Isotopes in Perimeter Soil for an Off-Site Resident (Nonspecific County) (From ESR 1991-1996 Data, see Table D.3.5-5)-Continued

Uranium Conversion:		U=	4.4	μg/g
pCi U isotope / g soil = μg total Uranium/g soil X RMA X SA X CF				
RMA = relative mass abundance (g isotope per g total U)				
SA = specific activity (pCi/g)				
CF = conversion factor (1E-06 g/μg)				
U-238 =	1.46E+00 pCi/g		RMA	SA
			0.9928	3.35E+05
U-235 =	6.84E-02 pCi/g		0.0072	2.16E+06
U-234 =	1.59E+00 pCi/g		0.000058	6.24E+09
Total U Activity =	3.12E+00 pCi/g			

TABLE D.3.3-16.—Ingestion of Metals in Perimeter Soil to an Off-Site Resident (Nonspecific County)
 (From ESR 1992-1996 Data, see Table D.3.5-5)

ANALYTES	95% UCL (mg/kg)	AVERAGE- CASE CHRONIC DAILY INTAKE mg/kg-day	WORST- CASE CHRONIC DAILY INTAKE mg/kg-day	ORAL RfD mg/kg-day	ORAL SLOPE FACTOR per (mg/kg)/day	AVERAGE- CASE HAZARD INDEX	WORST- CASE HAZARD INDEX	AVERAGE- CASE CANCER RISK	WORST- CASE CANCER RISK
AG	1.40E+00	1.95E-06	7.80E-06	5.0E-03	-	3.90E-04	1.56E-03		
AL	3.50E+00	4.87E-06	1.95E-05	1.8E-01	-	2.71E-05	1.08E-04		
AS ¹	3.90E+00	5.43E-06	2.17E-05	3.0E-04	1.5E+00	1.81E-02	7.24E-02	8.15E-06	3.26E-05
B	1.40E+01	1.95E-05	7.80E-05	9.0E-02	-	2.17E-04	8.67E-04		
BA	1.60E+02	2.23E-04	8.91E-04	7.0E-02	-	3.18E-03	1.27E-02		
BE ²	9.90E-01	1.38E-06	5.52E-06	5.0E-03	4.3E+00	2.76E-04	1.10E-03	5.93E-06	2.37E-05
CD	6.00E-01	8.36E-07	3.34E-06	5.0E-04	1.8E-03	1.67E-03	6.69E-03	1.50E-09	6.02E-09
CO	8.20E+00	1.14E-05	4.57E-05	6.0E-02	-	1.90E-04	7.61E-04		
CR	1.30E+01	1.81E-05	7.24E-05	1.0E+00	-	1.81E-05	7.24E-05		
CU	9.00E+00	1.25E-05	5.01E-05	1.9E-02	-	6.60E-04	2.64E-03		
HG	5.00E-02	6.96E-08	2.79E-07	3.0E-04	-	2.32E-04	9.29E-04		
MN	6.50E+02	9.05E-04	3.62E-03	1.4E-01	-	6.47E-03	2.59E-02		
MO	8.50E-01	1.18E-06	4.74E-06	5.0E-03	-	2.37E-04	9.47E-04		
NI	8.60E+00	1.20E-05	4.79E-05	2.0E-02	-	5.99E-04	2.40E-03		
PB	3.60E+01	5.01E-05	2.01E-04	1.4E-03	no data	3.58E-02	1.43E-01		
SB	1.70E-01	2.37E-07	9.47E-07	4.0E-04	-	5.92E-04	2.37E-03		
SE	6.40E-01	8.91E-07	3.57E-06	5.0E-03	-	1.78E-04	7.13E-04		
SN	1.00E+01	1.39E-05	5.57E-05	6.0E-01	-	2.32E-05	9.29E-05		
SR	3.60E+01	5.01E-05	2.01E-04	6.0E-01	-	8.36E-05	3.34E-04		
TL	1.70E+00	2.37E-06	9.47E-06	8.0E-05	-	2.96E-02	1.18E-01		

TABLE D.3.3-16.—Ingestion of Metals in Perimeter Soil to an Off-Site Resident (Nonspecific County)
 (From ESR 1992–1996 Data, see Table D.3.5-5)-Continued

ANALYTES	95% UCL (mg/kg)	AVERAGE-CASE CHRONIC DAILY INTAKE mg/kg-day	WORST-CASE CHRONIC DAILY INTAKE mg/kg-day	ORAL RFD mg/kg-day	ORAL SLOPE FACTOR per (mg/kg)/day	AVERAGE-CASE HAZARD INDEX	WORST-CASE HAZARD INDEX	AVERAGE-CASE CANCER RISK	WORST-CASE CANCER RISK
U	4.40E+00	6.13E-06	2.45E-05	3.0E-03	no data				
V	2.90E+01	4.04E-05	1.62E-04	9.0E-03	-	4.49E-03	1.80E-02		
ZN	4.90E+01	6.82E-05	2.73E-04	3.0E-01	-	2.27E-04	9.10E-04		

¹ Detected values of Arsenic had a mean of $2.37 \pm 1.53 \mu\text{g/g}$ (2 sigma).

² Detected values for Beryllium had a mean of $0.66 \pm 0.33 \mu\text{g/g}$ (2 sigma).

Note: gray shaded cells in Slope Factor column have no known human chemical cancer risk.

Note: gray shaded cells in Carcinogenic Risk columns have no known human cancer risk.

Perimeter Soil Ingestion Factors

$$\text{Intake (mg/kg-day)} = (\text{CS} \times \text{IR} \times \text{EF} \times \text{ED} \times \text{CF}) / (\text{BW} \times \text{AT})$$

Note: modified from EPA 1989, exhibit 6-12, pg. 6-36.

Value	Units	Parameter
e.g., B3	mg/kg	CS = perimeter soil concentration
1.00E+02	mg/day	IR = Average-Case ingestion rate
365	day/yr	EF = Average-Case exposure frequency
4.00E+02	mg/day	IR = Worst-Case ingestion rate
365	days/yr	EF = Worst-Case exposure frequency
75	yr	ED = Exposure duration
1.00E-06	kg/mg	CF = Conversion factor
71.8	kg	BW = Body weight
27375	d	AT = ED* 365 days

**TABLE D.3.3-17.—Ingestion of Radioactive Isotopes in Soil for a Resident Recreational User
(From ESR 1992-1996 Data, see Table D.3.5-5)**

ANALYTE	95% UCL (pCi/g)	DOSE CONVERSION FACTOR (rem/pCi)	AVERAGE-CASE DOSE (rem/year)	WORST-CASE DOSE (rem/year)
Americium-241	1.90E-02	4.50E-06	9.12E-08	3.65E-07
Cesium-137	1.01E+00	5.00E-08	5.39E-08	2.15E-07
Plutonium-238	2.20E-02	3.80E-06	8.92E-08	3.57E-07
Plutonium-239 and Plutonium-240	4.03E-01	4.30E-06	1.85E-06	7.39E-06
Strontium-90	7.80E-01	1.30E-07	1.08E-07	4.33E-07
Tritium ¹	2.59E-01	6.30E-11	1.74E-11	6.96E-11
Uranium ²	3.41E+00	2.60E-07	9.45E-07	3.78E-06
			Average-Case	Worst-Case
Total Dose (rem/yr)			3.14E-06	1.25E-05
Cancer Risk yr⁻¹			1.57E-09	6.27E-09
¹ Tritium was converted from pCi/mL using the formulas from Fresquez et al. 1996, Appendix B, pg. 36 (see below).				
² Uranium was similarly converted (see below).				
Average-Case Consumption				
	5.56E+00 mg/hr	=ingestion rate per hour		
	8 hr/event	=number of hours per visit		
	24 events/yr	=number of visits per year		
	1.07E+00 g/yr	=number of grams per year		
Worst-Case Consumption				
	2.22E+01 mg/hr	=ingestion rate per hour		
	8 hr/event	=number of hours per visit		
	24 events/yr	=number of visits per year		
	4.27E+00 g/yr	=number of grams per year		
	1 yr	=exposure duration		

Note: 100 mg per day over 18 hrs yields 5.56 mg/hr for Average-Case.

Note: 400 mg per day over 18 hrs yields 22.2 mg/hr for Worst-Case.

**TABLE D.3.3-17.—Ingestion of Radioactive Isotopes in Soil for a Resident Recreational User
(From ESR 1992-1996 Data, see Table D.3.5-5)-Continued**

Tritium Conversion:	H³=	2.33	pCi/mL
pCi/g = pCi/mL X (fraction soil moisture/soil moisture density X [1-fraction soil moisture])			
Fraction soil moisture = 10%			
Soil moisture density = 1 g/mL			
Tritium Activity (pCi/g) =	2.59E-01		
Uranium Conversion:	U=	4.8	µg/g
pCi U isotope / g soil = µg total Uranium/g soil X RMA X SA X CF			
RMA = relative mass abundance (g isotope per g total U)			
SA = specific activity (pCi/g)			
CF = conversion factor (1E-06 g/µg)			
		RMA	SA
U-238 =	1.60E+00 pCi/g	0.9928	3.35E+05
U-235 =	7.46E-02 pCi/g	0.0072	2.16E+06
U-234 =	1.74E+00 pCi/g	0.000058	6.24E+09
Total U Activity =	3.41E+00 pCi/g		

TABLE D.3.3-18.—Ingestion of Metals in Soil for a Resident Recreational User
(From ESR 1991-1996 Data, see Table D.3.5-5)

ANALYTES	95% UCL (µg/L)	AVERAGE- CASE CHRONIC DAILY INTAKE mg/kg-day	WORST- CASE CHRONIC DAILY INTAKE mg/kg-day	ORAL RfD mg/kg-day	ORAL SLOPE FACTOR per mg/kg/day	AVERAGE- CASE HAZARD INDEX	WORST- CASE HAZARD INDEX	AVERAGE- CASE CANCER RISK	WORST- CASE CANCER RISK
AG	2.30E+00	9.36E-08	3.74E-07	5.0E-03	-	1.87E-05	7.49E-05		
AL	4.30E+00	1.75E-07	7.00E-07	1.8E-01	-	9.72E-07	3.89E-06		
AS	3.70E+00	1.51E-07	6.02E-07	3.0E-04	1.5E+00	5.02E-04	2.01E-03	2.26E-07	9.04E-07
B	2.40E+01	9.77E-07	3.91E-06	9.0E-02	-	1.09E-05	4.34E-05		
BA	1.70E+02	6.92E-06	2.77E-05	7.0E-02	-	9.88E-05	3.95E-04		
BE	1.00E+00	4.07E-08	1.63E-07	5.0E-03	4.3E+00	8.14E-06	3.26E-05	1.75E-07	7.00E-07
CD	2.70E-01	1.10E-08	4.40E-08	5.0E-04	1.8E-03	2.20E-05	8.79E-05	1.98E-11	7.91E-11
CO	7.90E+00	3.22E-07	1.29E-06	6.0E-02	-	5.36E-06	2.14E-05		
CR	1.20E+01	4.88E-07	1.95E-06	1.0E+00	-	4.88E-07	1.95E-06		
CU	9.70E+00	3.95E-07	1.58E-06	1.9E-02	-	2.08E-05	8.31E-05		
FE	1.80E+00	7.33E-08	2.93E-07	-	-				
HG	4.00E-02	1.63E-09	6.51E-09	3.0E-04	-	5.43E-06	2.17E-05		
MN	6.10E+02	2.48E-05	9.93E-05	1.4E-01	-	1.77E-04	7.09E-04		
MO	9.30E-01	3.79E-08	1.51E-07	5.0E-03	-	7.57E-06	3.03E-05		
NI	9.70E+00	3.95E-07	1.58E-06	2.0E-02	-	1.97E-05	7.90E-05		
PB	3.00E+01	1.22E-06	4.88E-06	1.4E-03	no data	8.72E-04	3.49E-03		
SB	4.50E-01	1.83E-08	7.33E-08	4.0E-04	-	4.58E-05	1.83E-04		
SE	4.80E-01	1.95E-08	7.81E-08	5.0E-03	-	3.91E-06	1.56E-05		
SN	1.20E+01	4.88E-07	1.95E-06	6.0E-01	-	8.14E-07	3.26E-06		
SR	3.90E+01	1.59E-06	6.35E-06	6.0E-01	-	2.65E-06	1.06E-05		
TLL	9.30E-01	3.79E-08	1.51E-07	8.0E-05	-	4.73E-04	1.89E-03		

TABLE D.3.3-18.—Ingestion of Metals in Soil for a Resident Recreational User
(From ESR 1991-1996 Data, see Table D.3.5-5)-Continued

ANALYTES	95% UCL (µg/L)	AVERAGE-CASE CHRONIC DAILY INTAKE		ORAL RFD mg/kg-day	ORAL SLOPE FACTOR per mg/kg/day	AVERAGE-CASE HAZARD INDEX		WORST-CASE HAZARD INDEX		AVERAGE-CASE CANCER RISK		WORST-CASE CANCER RISK	
		mg/kg-day	mg/kg-day			mg/kg-day	mg/kg-day	mg/kg-day	mg/kg-day	mg/kg-day	mg/kg-day	mg/kg-day	mg/kg-day
U	4.80E+00	1.95E-07	7.81E-07	3.0E-03	no data	6.51E-05	2.60E-04	1.36E-04	5.43E-04	6.65E-06	2.66E-05		
V	3.00E+01	1.22E-06	4.88E-06	9.0E-03	-								
ZN	4.90E+01	1.99E-06	7.98E-06	3.0E-01	-								

Note: gray shaded cells in Slope Factor column have no known human chemical cancer risk.

Note: gray shaded cells in Carcinogenic Risk columns have no known human cancer risk.

On-Site Soil Ingestion Factors - Resident Recreational User

Intake (mg/kg/day) = (CW x IR x ET x EF x ED x CF)/(BW x AT)

Note: modified from EPA 1989, exhibit 6-12, pg. 6-36.

Value	Units	Parameter
e.g., B3	mg/kg	CW = On-site concentration
5.56E+00	mg/hr	IR = Average-Case ingestion rate
8	hr/event	ET = Average-Case exposure time
24	events/yr	EF = Average-Case exposure frequency
2.22E+01	mg/hr	IR = Worst-Case ingestion rate
8	hr/event	ET = Worst-Case exposure time
24	events/yr	EF = Worst-Case exposure frequency
75	yr	ED = Exposure duration
1.00E-06	kg/mg	CF = Conversion factor
71.8	kg	BW = Body weight
27375	d	AT = ED * 365 days

Note: 100 mg per day over 18 hrs yields 5.56 mg per hour for Average-Case.

Note: 400 mg per day over 18 hrs yields 22.2 mg per hour for Worst-Case.

TABLE D.3.3–19.—Ingestion of Radioactive Isotopes in Soil for a Nonresident Recreational User
(From ESR 1992–1996 Data, see Table D.3.5–5)

ANALYTE	95% UCL (pCi/g)	DOSE CONVERSION FACTOR (rem/pCi)	AVERAGE-CASE DOSE (rem/year)	WORST-CASE DOSE (rem/year)
Americium-241	1.90E-02	4.50E-06	3.42E-08	1.37E-07
Cesium-137	1.01E+00	5.00E-08	2.02E-08	8.08E-08
Plutonium-238	2.20E-02	3.80E-06	3.34E-08	1.34E-07
Plutonium-239 and Plutonium-240	4.03E-01	4.30E-06	6.93E-07	2.77E-06
Strontium-90	7.80E-01	1.30E-07	4.06E-08	1.62E-07
Tritium ¹	2.59E-01	6.30E-11	6.52E-12	2.61E-11
Uranium ²	3.41E+00	2.60E-07	3.54E-07	1.42E-06
			Average-Case	Worst-Case
Total Dose (rem/yr)			1.18E-06	4.70E-06
Cancer Risk yr⁻¹			5.88E-10	2.35E-09
¹ Tritium was converted from pCi/mL using the formulas from Fresquez et al. 1996, Appendix B, pg. 36 (see below).				
² Uranium was similarly converted (see below).				
Average-Case Consumption				
	5.56E+00 mg/hr	=ingestion rate per hour		
	6 hr/event	=number of hours per visit		
	12 events/yr	=number of visits per year		
	4.00E-01 g/yr	=number of grams per year		
Worst-Case Consumption				
	2.22E+01 mg/hr	=ingestion rate per hour		
	6 hr/event	=number of hours per visit		
	12 events/yr	=number of visits per year		
	1.60E+00 g/yr	=number of grams per year		
	1 yr	=exposure duration		

Note: 100 mg per day over 18 hrs yields 5.56 mg/hr for Average-Case.

Note: 400 mg per day over 18 hrs yields 22.2 mg/hr for Worst-Case.

**TABLE D.3.3-19.—Ingestion of Radioactive Isotopes in Soil for a Nonresident Recreational User
(From ESR 1992-1996 Data, see Table D.3.5-5)-Continued**

Tritium Conversion:	H³=	2.33	pCi/mL
pCi/g = pCi/mL X (fraction soil moisture /soil moisture density X [1-fraction soil moisture]) fraction soil moisture = 10% soil moisture density = 1 g/mL			
Tritium Activity (pCi/g) =	2.59E-01		
Uranium Conversion:	U=	4.8	µg/g
pCi U isotope / g soil = µg total Uranium/g soil X RMA X SA X CF RMA = relative mass abundance (g isotope per g total U) SA = specific activity (pCi/g) CF = conversion factor (1E-06 g/µg)			
		RMA	SA
U-238 =	1.60E+00 pCi/g	0.9928	3.35E+05
U-235 =	7.46E-02 pCi/g	0.0072	2.16E+06
U-234 =	1.74E+00 pCi/g	0.000058	6.24E+09
Total U Activity =	3.41E+00 pCi/g		

TABLE D.3.3-20.—Ingestion of Metals in Soils to a Nonresident Recreational User
(From ESR 1991–1996 Data, see Table D.3.5-5)

ANALYTES	95% UCL (µg/L)	AVERAGE- CASE CHRONIC DAILY INTAKE mg/kg-day	WORST- CASE CHRONIC DAILY INTAKE mg/kg-day	ORAL RfD mg/kg-day	ORAL SLOPE FACTOR per mg/kg/day	AVERAGE- CASE HAZARD INDEX	WORST- CASE HAZARD INDEX	AVERAGE- CASE CANCER RISK	WORST- CASE CANCER RISK
AG	2.30E+00	3.51E-08	1.40E-07	5.0E-03	-	7.02E-06	2.81E-05		
AL	4.30E+00	6.56E-08	2.63E-07	1.8E-01	-	3.65E-07	1.46E-06		
AS	3.70E+00	5.65E-08	2.26E-07	3.0E-04	1.5E+00	1.88E-04	7.53E-04	8.47E-08	3.39E-07
B	2.40E+01	3.66E-07	1.47E-06	9.0E-02	-	4.07E-06	1.63E-05		
BA	1.70E+02	2.59E-06	1.04E-05	7.0E-02	-	3.71E-05	1.48E-04		
BE	1.00E+00	1.53E-08	6.11E-08	5.0E-03	4.3E+00	3.05E-06	1.22E-05	6.56E-08	2.63E-07
CD	2.70E-01	4.12E-09	1.65E-08	5.0E-04	1.8E-03	8.24E-06	3.30E-05	7.42E-12	2.97E-11
CO	7.90E+00	1.21E-07	4.82E-07	6.0E-02	-	2.01E-06	8.04E-06		
CR	1.20E+01	1.83E-07	7.33E-07	1.0E+00	-	1.83E-07	7.33E-07		
CU	9.70E+00	1.48E-07	5.92E-07	1.9E-02	-	7.79E-06	3.12E-05		
FE	1.80E+00	2.75E-08	1.10E-07	-	-				
HG	4.00E-02	6.11E-10	2.44E-09	3.0E-04	-	2.04E-06	8.14E-06		
MN	6.10E+02	9.31E-06	3.72E-05	1.4E-01	-	6.65E-05	2.66E-04		
MO	9.30E-01	1.42E-08	5.68E-08	5.0E-03	-	2.84E-06	1.14E-05		
NI	9.70E+00	1.48E-07	5.92E-07	2.0E-02	-	7.40E-06	2.96E-05		
PB	3.00E+01	4.58E-07	1.83E-06	1.4E-03	no data	3.27E-04	1.31E-03		
SB	4.50E-01	6.87E-09	2.75E-08	4.0E-04	-	1.72E-05	6.87E-05		
SE	4.80E-01	7.33E-09	2.93E-08	5.0E-03	-	1.47E-06	5.86E-06		
SN	1.20E+01	1.83E-07	7.33E-07	6.0E-01	-	3.05E-07	1.22E-06		
SR	3.90E+01	5.95E-07	2.38E-06	6.0E-01	-	9.92E-07	3.97E-06		
TL	9.30E-01	1.42E-08	5.68E-08	8.0E-05	-	1.77E-04	7.10E-04		

TABLE D.3.3-20.—Ingestion of Metals in Soils to a Nonresident Recreational User
 (From ESR 1991-1996 Data, see Table D.3.5-5)-Continued

ANALYTES	95% UCL (µg/L)	AVERAGE-CASE		ORAL RFD mg/kg-day	ORAL SLOPE FACTOR per mg/kg/day	AVERAGE-CASE		WORST-CASE HAZARD INDEX	AVERAGE-CASE		WORST-CASE HAZARD INDEX	WORST-CASE CANCER RISK
		CHRONIC DAILY INTAKE mg/kg-day	CHRONIC DAILY INTAKE mg/kg-day			HAZARD INDEX	HAZARD INDEX					
U	4.80E+00	7.33E-08	2.93E-07	3.0E-03	no data	2.44E-05	9.77E-05	2.04E-04	9.97E-06			
V	3.00E+01	4.58E-07	1.83E-06	9.0E-03	-	5.09E-05	2.04E-04	9.97E-06				
ZN	4.90E+01	7.48E-07	2.99E-06	3.0E-01	-	2.49E-06	9.97E-06					

Note: gray shaded cells in Slope Factor column have no known human chemical cancer risk.
 Note: gray shaded cells in Carcinogenic Risk columns have no known human cancer risk.

On-Site Soil Ingestion Factors - Nonresident Recreational User

Intake (mg/kg/day) = (CW x IR x ET x EF x ED x CF)/(BW x AT)

Note: modified from EPA 1989, exhibit 6-12, pg. 6-36.

Value	Units	Parameter
e.g., B3	mg/kg	CW = On-site concentration
5.56E+00	mg/hr	IR = Average-Case ingestion rate
6	hr/event	ET = Average-Case exposure time
12	events/yr	EF = Average-Case exposure frequency
2.22E+01	mg/hr	IR = Worst-Case ingestion rate
6	hr/event	ET = Worst-Case exposure time
12	events/yr	EF = Worst-Case exposure frequency
1	yr	ED = Exposure duration
1.00E-06	kg/mg	CF = Conversion factor
71.8	kg	BW = Body weight

Note: 100 mg per day over 18 hrs yields 5.56 mg per hour for Average-Case.
 Note: 400 mg per day over 18 hrs yields 22.2 mg per hour for Worst-Case.

TABLE D.3.3-21.—Ingestion of Radioactive Isotopes in Perimeter Sediment for an Off-Site Resident (Nonspecific County)
(From ESR 1991-1996 Data, see Table C-4)

ANALYTE	95% UCL (pCi/g)	DOSE CONVERSION FACTOR (rem/pCi)	AVERAGE-CASE DOSE (rem/year)	WORST-CASE DOSE (rem/year)
Americium-241	2.20E-01	4.50E-06	3.61E-05	1.45E-04
Cesium-137	9.90E-01	5.00E-08	1.81E-06	7.23E-06
Plutonium-238	2.70E-02	3.80E-06	3.74E-06	1.50E-05
Plutonium-239 and Plutonium-240	3.70E+00	4.30E-06	5.81E-04	2.32E-03
Strontium-90	9.30E-01	1.30E-07	4.41E-06	1.77E-05
Tritium ¹	2.11E-01	6.30E-11	4.85E-10	1.94E-09
Uranium ²	2.98E+00	2.60E-07	2.83E-05	1.13E-04
			Average-Case	Worst-Case
Total Dose (rem/yr)			6.55E-04	2.62E-03
Cancer Risk yr⁻¹			3.28E-07	1.31E-06
¹ Tritium was converted from pCi/ml using the formulas from Fresquez et al. 1996, Appendix B, pg. 36 (see below).				
² Uranium was similarly converted (see below).				
Average-Case Consumption				
	1.00E+02 mg/day	=number of mg per day		
	365 days/yr	=number of days per year		
	3.65E+01 g/yr	=number of grams per year		
Worst-Case Consumption				
	4.00E+02 mg/day	=number of mg per day		
	365 days/yr	=number of days per year		
	1.46E+02 g/yr	=number of grams per year		
	1 yr	=exposure duration		
Tritium Conversion:		H³=	1.9	pCi/mL
pCi/g = pCi/ml X (fraction soil moisture /soil moisture density X [1-fraction soil moisture])				
fraction soil moisture = 10%				
soil moisture density = 1 g/ml				
Tritium Activity (pCi/g) = 2.11E-01				

TABLE D.3.3-21.—Ingestion of Radioactive Isotopes in Perimeter Sediment for an Off-Site Resident (Nonspecific County)
(From ESR 1991-1996 Data, see Table C-4)-Continued

Uranium Conversion:		U=	4.2	µg/g
pCi U isotope / g soil = µg total Uranium/g soil X RMA X SA X CF				
RMA = relative mass abundance (g isotope per g total U)				
SA = specific activity (pCi/g)				
CF = conversion factor (1E-06 g/µg)				
			RMA	SA
U-238 =	1.40E+00 pCi/g		0.9928	3.35E+05
U-235 =	6.53E-02 pCi/g		0.0072	2.16E+06
U-234 =	1.52E+00 pCi/g		0.000058	6.24E+09
Total U Activity =	2.98E+00 pCi/g			

TABLE D.3.3-22.—Ingestion of Metals in Perimeter Sediments to an Off-Site Resident (Nonspecific County)
(From ESR 1991-1996 Data, see Table C-4)-Continued

ANALYTES	95% UCL (mg/kg)	AVERAGE-CASE		WORST-CASE		ORAL SLOPE FACTOR per (mg/kg)/day	AVERAGE-CASE HAZARD INDEX	WORST-CASE HAZARD INDEX	AVERAGE-CASE CANCER RISK	WORST-CASE CANCER RISK
		CHRONIC DAILY INTAKE mg/kg-day	CHRONIC DAILY INTAKE mg/kg-day	ORAL RfD mg/kg-day	ORAL RfD mg/kg-day					
U	4.20E+00	5.85E-06	2.34E-05	3.0E-03	3.0E-03	no data	1.95E-03	7.80E-03		
V	2.40E+01	3.34E-05	1.34E-04	9.0E-03	9.0E-03	-	3.71E-03	1.49E-02		
ZN	1.10E+02	1.53E-04	6.13E-04	3.0E-01	3.0E-01	-	5.11E-04	2.04E-03		

¹ Detected values of Arsenic had a mean of 2.1 ± 12.9 µg/g (2 sigma).

² Detected values for Beryllium had a mean of 0.49 ± 0.51 µg/g (2 sigma).

Note: gray shaded cells in Slope Factor column have no known human chemical cancer risk.

Note: gray shaded cells in Carcinogenic Risk columns have no known human cancer risk.

Perimeter Sediment Ingestion Factors

$$\text{Intake (mg/kg-day)} = (\text{CS} \times \text{IR} \times \text{EF} \times \text{ED} \times \text{CF}) / (\text{BW} \times \text{AT})$$

Note: modified from EPA 1989, exhibit 6-12, pg. 6-36.

Value	Units	Parameter
e.g., B3	mg/kg	CS = perimeter sediment concentration
1.00E+02	mg/day	IR = Average-Case ingestion rate
365	day/yr	EF = Average-Case exposure frequency
4.00E+02	mg/day	IR = Worst-Case ingestion rate
365	days/yr	EF = Worst-Case exposure frequency
75	yr	ED = Exposure duration
1.00E-06	kg/mg	CF = Conversion factor
71.8	kg	BW = Body weight
27375	d	AT = ED* 365 days

**TABLE D.3.3–23.—Ingestion of Radioactive Isotopes in Sediment for a Resident Recreational User
(From ESR 1991–1996 Data, see Table C-4)**

ANALYTE	95% UCL (pCi/g)	DOSE CONVERSION FACTOR (rem/pCi)	AVERAGE-CASE DOSE (rem/year)	WORST-CASE DOSE (rem/year)
Americium-241	3.80E+00	4.50E-06	1.82E-05	7.30E-05
Cesium-137	1.80E+01	5.00E-08	9.60E-07	3.84E-06
Plutonium-238	1.70E+00	3.80E-06	6.89E-06	2.76E-05
Plutonium-239 and Plutonium-240	3.70E+00	4.30E-06	1.70E-05	6.79E-05
Strontium-90	1.60E+00	1.30E-07	2.22E-07	8.87E-07
Tritium ¹	3.11E+00	6.30E-11	2.09E-10	8.36E-10
Uranium ²	2.70E+00	2.60E-07	7.48E-07	2.99E-06
			Average-Case	Worst-Case
Total Dose (rem/yr)			4.40E-05	1.76E-04
Cancer Risk yr⁻¹			2.20E-08	8.81E-08
¹ Tritium was converted from pCi/mL using the formulas from Fresquez et al. 1996, Appendix B, pg. 36 (see below).				
² Uranium was similarly converted (see below).				
Average-Case Consumption				
	5.56E+00 mg/hr	=ingestion rate per hour		
	8 hr/event	=number of hours per visit		
	24 events/yr	=number of visits per year		
	1.07E+00 g/yr	=number of grams per year		
Worst-Case Consumption				
	2.22E+01 mg/hr	=ingestion rate per hour		
	8 hr/event	=number of hours per visit		
	24 events/yr	=number of visits per year		
	4.27E+00 g/yr	=number of grams per year		
	1 yr	=exposure duration		

Note: 100 mg per day over 18 hrs yields 5.56 mg/hr for Average-Case.

Note: 400 mg per day over 18 hrs yields 22.2 mg/hr for Worst-Case.

**TABLE D.3.3-23.—Ingestion of Radioactive Isotopes in Sediment for a Resident Recreational User
(From ESR 1991-1996 Data, see Table C-4)-Continued**

Tritium Conversion:		H³=	28	pCi/mL
pCi/g = pCi/mL X (fraction soil moisture/soil moisture density X [1-fraction soil moisture])				
Fraction soil moisture = 10%				
Soil moisture density = 1 g/mL				
Tritium Activity (pCi/g) =		3.11E+00		
Uranium Conversion:		U=	3.8	µg/g
pCi U isotope / g soil = µg total Uranium/g soil X RMA X SA X CF				
RMA = relative mass abundance (g isotope per g total U)				
SA = specific activity (pCi/g)				
CF = conversion factor (1E-06 g/µg)				
			RMA	SA
U-238 =	1.26E+00 pCi/g		0.9928	3.35E+05
U-235 =	5.91E-02 pCi/g		0.0072	2.16E+06
U-234 =	1.38E+00 pCi/g		0.000058	6.24E+09
Total U Activity =	2.70E+00 pCi/g			

TABLE D.3.3-24.—Ingestion of Metals in Sediment for a Resident Recreational User
(From ESR 1991–1996 Data, see Table C-4)

ANALYTES	95% UCL (µg/L)	AVERAGE-CASE		WORST-CASE CHRONIC DAILY INTAKE mg/kg-day	ORAL RFD mg/kg-day	ORAL SLOPE FACTOR per mg/kg/day	AVERAGE- HAZARD INDEX		WORST- HAZARD INDEX		AVERAGE- CASE CANCER RISK		WORST- CASE CANCER RISK	
		CHRONIC DAILY INTAKE mg/kg-day	CHRONIC DAILY INTAKE mg/kg-day				HAZARD INDEX	HAZARD INDEX	HAZARD INDEX	HAZARD INDEX	CASE CANCER RISK	CASE CANCER RISK		
AG	1.00E+01	4.07E-07	1.63E-06	5.0E-03	-	8.14E-05	3.26E-04	8.14E-05	3.26E-04	2.98E-07	1.19E-06	2.98E-07	1.19E-06	
AL	1.50E+04	6.11E-04	2.44E-03	1.8E-01	-	3.39E-03	1.36E-02	3.39E-03	1.36E-02	2.08E-07	8.30E-07	2.08E-07	8.30E-07	
AS	3.40E+00	1.38E-07	5.54E-07	3.0E-04	1.5E+00	4.61E-04	1.85E-03	4.61E-04	1.85E-03					
B	3.90E+01	1.59E-06	6.35E-06	9.0E-02	-	1.76E-05	7.05E-05	1.76E-05	7.05E-05					
BA	2.90E+02	1.18E-05	4.72E-05	7.0E-02	-	1.69E-04	6.74E-04	1.69E-04	6.74E-04					
BE	1.70E+00	6.92E-08	2.77E-07	5.0E-03	4.3E+00	1.38E-05	5.54E-05	1.38E-05	5.54E-05	2.98E-07	1.19E-06	2.98E-07	1.19E-06	
CD	1.50E+00	6.11E-08	2.44E-07	5.0E-04	1.8E-03	1.22E-04	4.88E-04	1.22E-04	4.88E-04	1.10E-10	4.40E-10	1.10E-10	4.40E-10	
CO	8.40E+00	3.42E-07	1.37E-06	6.0E-02	-	5.70E-06	2.28E-05	5.70E-06	2.28E-05					
CR	1.80E+02	7.33E-06	2.93E-05	1.0E+00	-	7.33E-06	2.93E-05	7.33E-06	2.93E-05					
CU	1.20E+01	4.88E-07	1.95E-06	1.9E-02	-	2.57E-05	1.03E-04	2.57E-05	1.03E-04					
FE	1.50E+04	6.11E-04	2.44E-03	-	-	-	-	-	-					
HG	8.70E-02	3.54E-09	1.42E-08	3.0E-04	-	1.18E-05	4.72E-05	1.18E-05	4.72E-05					
LI	2.90E+01	1.18E-06	4.72E-06	2.0E-02	-	5.90E-05	2.36E-04	5.90E-05	2.36E-04					
MN	5.00E+02	2.04E-05	8.14E-05	1.4E-01	-	1.45E-04	5.81E-04	1.45E-04	5.81E-04					
MO	6.40E+00	2.60E-07	1.04E-06	5.0E-03	-	5.21E-05	2.08E-04	5.21E-05	2.08E-04					
NI	1.30E+01	5.29E-07	2.12E-06	2.0E-02	-	2.65E-05	1.06E-04	2.65E-05	1.06E-04					
PB	3.80E+01	1.55E-06	6.19E-06	1.4E-03	no data	1.10E-03	4.42E-03	1.10E-03	4.42E-03					
SB	9.80E+00	3.99E-07	1.60E-06	4.0E-04	-	9.97E-04	3.99E-03	9.97E-04	3.99E-03					
SE	6.00E-01	2.44E-08	9.77E-08	5.0E-03	-	4.88E-06	1.95E-05	4.88E-06	1.95E-05					
SN	7.30E+01	2.97E-06	1.19E-05	6.0E-01	-	4.95E-06	1.98E-05	4.95E-06	1.98E-05					
SR	1.80E+02	7.33E-06	2.93E-05	6.0E-01	-	1.22E-05	4.88E-05	1.22E-05	4.88E-05					
TL	1.00E+01	4.07E-07	1.63E-06	8.0E-05	-	5.09E-03	2.04E-02	5.09E-03	2.04E-02					

TABLE D.3.3-24.—Ingestion of Metals in Sediment for a Resident Recreational User
(From ESR 1991–1996 Data, see Table C-4)-Continued

ANALYTES	95% UCL (µg/L)	AVERAGE- CASE		WORST- CASE CHRONIC DAILY INTAKE mg/kg-day	ORAL RFD mg/kg-day	ORAL SLOPE FACTOR per mg/kg/day	AVERAGE- CASE		WORST- CASE HAZARD INDEX	AVERAGE- CASE		WORST- CASE HAZARD INDEX	AVERAGE- CASE		WORST- CASE HAZARD INDEX
		CHRONIC DAILY INTAKE mg/kg-day	CHRONIC DAILY INTAKE mg/kg-day				HAZARD INDEX	HAZARD INDEX		HAZARD INDEX	HAZARD INDEX				
U	3.80E+00	1.55E-07	6.19E-07	3.0E-03	no data		5.16E-05	2.06E-04		1.99E-07	7.98E-07				
V	3.90E+01	1.59E-06	6.35E-06	9.0E-03	-		1.76E-04	7.05E-04							
ZN	1.60E+02	6.51E-06	2.60E-05	3.0E-01	-		2.17E-05	8.68E-05							
Bis(2- ethylhexyl) phthalate	3.50E+02	1.42E-05	5.70E-05	2.0E-02	1.4E-02		7.12E-04	2.85E-03		1.99E-07	7.98E-07				
Di-n-butyl phthalate	9.90E+02	4.03E-05	1.61E-04	1.0E-01			4.03E-04	1.61E-03							

Note: gray shaded cells in Slope Factor column have no known human chemical cancer risk.

Note: gray shaded cells in Carcinogenic Risk columns have no known human cancer risk.

TABLE D.3.3-24.—Ingestion of Metals in Sediment for a Resident Recreational User
(From ESR 1991–1996 Data, see Table C-4)-Continued

On-Site Sediment Ingestion Factors - Resident Recreational User

Intake (mg/kg/day) = (CW x IR x ET x EF x ED x CF)/(BW x AT)

Note: modified from EPA 1989, exhibit 6-12, pg. 6-36.

Value	Units	Parameter
e.g., B3	mg/kg	CW = On-site concentration
5.56E+00	mg/hr	IR = Average-Case ingestion rate
8	hr/event	ET = Average-Case exposure time
24	events/yr	EF = Average-Case exposure frequency
2.22E+01	mg/hr	IR = Worst-Case ingestion rate
8	hr/event	ET = Worst-Case exposure time
24	events/yr	EF = Worst-Case exposure frequency
75	yr	ED = Exposure duration
1.00E-06	kg/mg	CF = Conversion factor
71.8	kg	BW = Body weight
27375	d	AT = ED* 365 days

Note: 100 mg per day over 18 hrs yields 5.56 mg per hour for Average-Case.

Note: 400 mg per day over 18 hrs yields 22.2 mg per hour for Worst-Case.

TABLE D.3.3–25.—Ingestion of Radioactive Isotopes in Sediment for a Nonresident Recreational User (From ESR 1991–1996 Data, see Table C-4)

ANALYTE	95% UCL (pCi/g)	DOSE CONVERSION FACTOR (rem/pCi)	AVERAGE-CASE DOSE (rem/year)	WORST-CASE DOSE (rem/year)
Americium-241	3.80E+00	4.50E-06	6.84E-06	2.74E-05
Cesium-137	1.80E+01	5.00E-08	3.60E-07	1.44E-06
Plutonium-238	1.70E+00	3.80E-06	2.58E-06	1.03E-05
Plutonium-239 and Plutonium-240	3.70E+00	4.30E-06	6.36E-06	2.55E-05
Strontium-90	1.60E+00	1.30E-07	8.32E-08	3.33E-07
Tritium ¹	3.11E+00	6.30E-11	7.84E-11	3.14E-10
Uranium ²	2.70E+00	2.60E-07	2.81E-07	1.12E-06
			Average-Case	Worst-Case
Total Dose (rem/yr)			1.65E-05	6.60E-05
Cancer Risk yr⁻¹			8.26E-09	3.30E-08
¹ Tritium was converted from pCi/mL using the formulas from Fresquez, 1996 et al. Appendix B, pg. 36 (see below).				
² Uranium was similarly converted (see below).				
Average-Case Consumption				
	5.56E+00 mg/hr	=ingestion rate per hour		
	6 hr/event	=number of hours per visit		
	12 events/yr	=number of visits per year		
	4.00E-01 g/yr	=number of grams per year		
Worst-Case Consumption				
	2.22E+01 mg/hr	=ingestion rate per hour		
	6 hr/event	=number of hours per visit		
	12 events/yr	=number of visits per year		
	1.60E+00 g/yr	=number of grams per year		
	1 yr	=exposure duration		

Note: 100 mg per day over 18 hrs yields 5.56 mg/hr for Average-Case.

Note: 400 mg per day over 18 hrs yields 22.2 mg/hr for Worst-Case.

TABLE D.3.3-25.—Ingestion of Radioactive Isotopes in Sediment for a Nonresident Recreational User (From ESR 1991-1996 Data, see Table C-4)-Continued

Tritium Conversion:		H³=	28	pCi/mL
pCi/g = pCi/mL X (fraction soil moisture/soil moisture density X [1-fraction soil moisture])				
Fraction soil moisture = 10%				
Soil moisture density = 1 g/mL				
Tritium Activity (pCi/g) =		3.11E+00		
Uranium Conversion:		U=	3.8	µg/g
pCi U isotope / g soil = µg total Uranium/g soil X RMA X SA X CF				
RMA = relative mass abundance (g isotope per g total U)				
SA = specific activity (pCi/g)				
CF = conversion factor (1E-06 g/µg)				
			RMA	SA
U-238 =	1.26E+00 pCi/g		0.9928	3.35E+05
U-235 =	5.91E-02 pCi/g		0.0072	2.16E+06
U-234 =	1.38E+00 pCi/g		0.000058	6.24E+09
Total U Activity =	2.70E+00 pCi/g			

TABLE D.3.3-26.—Ingestion of Metals in Sediment for a Nonresident Recreational User
 (From ESR 1991-1996 Data, see Table C-4)-Continued

ANALYTES	95% UCL (µg/L)	AVERAGE-CASE CHRONIC		WORST-CASE CHRONIC DAILY INTAKE mg/kg-day	ORAL RFD mg/kg-day	ORAL SLOPE FACTOR per mg/kg/day	AVERAGE- HAZARD INDEX	WORST- CASE HAZARD INDEX	AVERAGE- CASE CANCER RISK	WORST- CASE CANCER RISK
		DAILY INTAKE mg/kg-day	CHRONIC DAILY INTAKE mg/kg-day							
U	3.80E+00	5.80E-08	2.32E-07	3.0E-03	no data	no data	1.93E-05	7.73E-05		
V	3.90E+01	5.95E-07	2.38E-06	9.0E-03	-	-	6.61E-05	2.65E-04		
ZN	1.60E+02	2.44E-06	9.77E-06	3.0E-01	-	-	8.14E-06	3.26E-05		
Bis(2-ethylhexyl) phthalate	3.50E+02	5.34E-06	2.14E-05	2.0E-02	1.4E-02	1.4E-02	2.67E-04	1.07E-03	7.48E-08	2.99E-07
Di-n-butyl phthalate	9.90E+02	1.51E-05	6.04E-05	1.0E-01			1.51E-04	6.04E-04		

TABLE D.3.3-26.—Ingestion of Metals in Sediment for a Nonresident Recreational User
(From ESR 1991-1996 Data, see Table C-4)-Continued

Note: gray shaded cells in Slope Factor column have no known human chemical cancer risk.
Note: gray shaded cells in Carcinogenic Risk columns have no known human cancer risk.

On-Site Sediment Ingestion Factors - Nonresident Recreational User

Intake (mg/kg/day) = (CW x IR x ET x EF x ED x CF)/(BW x AT)

Note: modified from EPA 1989, exhibit 6-12, pg. 6-36.

Value	Units	Parameter
e.g., B3	mg/kg	CW = On-site concentration
5.56E+00	mg/hr	IR = Average-Case ingestion rate
6	hr/event	ET = Average-Case exposure time
12	events/yr	EF = Average-Case exposure frequency
2.22E+01	mg/hr	IR = Worst-Case ingestion rate
6	hr/event	ET = Worst-Case exposure time
12	events/yr	EF = Worst-Case exposure frequency
1	yr	ED = Exposure duration
1.00E-06	kg/mg	CF = Conversion factor
71.8	kg	BW = Body weight
365	d	AT = ED* 365 days

Note: 100 mg per day over 18 hrs yields 5.56 mg per hour for Average-Case.

Note: 400 mg per day over 18 hrs yields 22.2 mg per hour for Worst-Case.

TABLE D.3.3–27.—Ingestion of Honey for Off-Site Residents (Note: Includes LANL 1990–1994 Los Alamos and White Rock County Data for Los Alamos County and San Ildefonso Data for Non-Los Alamos County Resident) (Foodstuffs Database 1990–1994, see Table D.3.5–6)

ANALYTE	95% UCL (pCi/g) dry wt.	DOSE CONVERSION FACTOR (rem/pCi)	AVERAGE- CASE DOSE (rem/year)	WORST- CASE DOSE (rem/year)
Los Alamos County Tritium ¹	4.64E+01	6.30E-11	7.37E-07	2.63E-06
Non-Los Alamos County Tritium	7.92E-01	6.30E-11	1.26E-08	4.49E-08
¹ 95% UCL concentration in % of food that is water				
	LOS ALAMOS COUNTY	LOS ALAMOS COUNTY	NON-LOS ALAMOS COUNTY	NON-LOS ALAMOS COUNTY
	Average- Case	Worst-Case	Average-Case	Worst-Case
Total Dose (rem/yr)	7.37E-07	2.63E-06	1.26E-08	4.49E-08
Cancer Risk yr-1	3.69E-10	1.32E-09	6.29E-12	2.25E-11
Average-Case Consumption (LANL 1997, Table 3-1)				
3.84 g/day	= number of grams of honey ingested per day			
0.69 g/day	= number of grams per day wet weight ingested			
Worst-Case Consumption (LANL 1997, Table 3-1)				
13.7 g/day	= number of grams of honey ingested per day			
2.47 g/day	= number of grams per day wet weight ingested			
Moisture Content (LANL 1997)				
0.18 unitless	= LANL fraction of honey that is water			
Exposure Duration				
365 days	= 1 yr exposure duration			
LAC Tritium Conversion				
	H ³ =	46.4	pCi/mL	
pCi/g of Tritium = pCi/mL tritium X mL/g of water				
water density =	1	g/mL		
Tritium Activity =	46.4	pCi/g		
Non-LAC Tritium Conversion				
	H ³ =	0.792	pCi/mL	
pCi/g of Tritium = pCi/mL tritium X mL/g of water				
water density =	1	g/mL		
Tritium Activity =	0.792	pCi/g		

TABLE D.3.3–28.—Ingestion of Free-Range Steer for an Off-Site Non-Los Alamos County Resident (see Table D.3.5–7)

ANALYTE	95% UCL (pCi/g) dry wt.	DOSE CONVERSION FACTOR (rem/pCi)	AVERAGE- CASE DOSE (rem/year)	WORST- CASE DOSE (rem/year)	
Americium-241	6.70E-05	4.50E-06	4.48E-06	1.09E-05	
Cesium-137	2.10E-02	5.00E-08	1.56E-05	3.79E-05	
Plutonium-238	3.00E-05	3.80E-06	1.69E-06	4.11E-06	
Plutonium-239	1.50E-04	4.30E-06	9.58E-06	2.33E-05	
Strontium-90	2.60E-02	1.30E-07	5.02E-05	1.22E-04	
Tritium	2.00E+02	6.30E-11	1.87E-04	4.55E-04	
Uranium	1.28E-03	2.60E-07	4.94E-06	1.20E-05	
			Average- Case	Worst-Case	
Total Dose (rem/yr)			2.74E-04	6.65E-04	
Cancer Risk yr-1			1.37E-07	3.32E-07	
Average-Case Consumption		(EPA 1997a, 71.8 kg Man)			
2.10 g/kg-day	= number of grams per day ingested				
40.71 g/day	= number of grams per day dry weight ingested				
Worst-Case Consumption		(EPA 1997a, 71.8 kg Man)			
5.10 g/kg/day	= number of grams per day ingested				
98.87 g/day	= number of grams per day dry weight ingested				
Dry/Wet Weight Fraction		(Fresquez and Ferenbaugh 1998)			
0.27 unitless	= LANL dry/wet weight ratio				
Exposure Duration					
365 days	= 1 yr exposure duration				
Tritium Conversion		H³=	200	pCi/mL	
pCi/g of Tritium = pCi/mL tritium X mL/g of water					
water density =	1	g/mL			
Tritium Activity =	200	pCi/g			
Uranium Conversion		U=	1.80E-03	µg/g	
pCi U isotope/g = µg total uranium/g X RMA X SA X CF					
RMA = relative mass abundance (g isotope per g total U)					
SA = specific activity (pCi/g)					
CF = conversion factor (1E-06 g/µg)					
			RMA	SA	CF
U-238=	5.99E-04	pCi/g	9.93E-01	3.35E+05	1.00E-06
U-235=	2.80E-05	pCi/g	7.20E-03	2.16E+06	1.00E-06
U-234=	6.51E-04	pCi/g	5.80E-05	6.24E+09	1.00E-06
Total U Activity =	1.28E-03	pCi/g			

TABLE D.3.3-29.—Ingestion of Elk for an Off-Site Los Alamos County Resident
 (Note: Includes LANL 1990–1994 Off-Site Road Kills (from Chama, Lindreth, and Tres Piedras, see Table D.3.5-6))

ANALYTE	95% UCL (pCi/g) dry wt.	DOSE CONVERSION FACTOR (rem/pCi)	AVERAGE- CASE DOSE (rem/year)	WORST- CASE DOSE (rem/year)	
Cesium-137	6.26E-01	5.00E-08	7.57E-05	1.84E-04	
Plutonium-238	0.00E+00	3.80E-06	0.00E+00	0.00E+00	
Plutonium-239	0.00E+00	4.30E-06	0.00E+00	0.00E+00	
Strontium-90	0.00E+00	1.30E-07	0.00E+00	0.00E+00	
Tritium ¹	(not analyzed)	6.30E-11			
Uranium	2.49E-03	2.60E-07	1.57E-06	3.80E-06	
¹ 95% UCL concentration in % of food that is water			Average- Case	Worst-Case	
Total Dose (rem/yr)			7.73E-05	1.87E-04	
Cancer Risk yr-1			3.87E-08	9.37E-08	
Average-Case Consumption		(EPA 1997a, General Population)			
26 g/day		= number of grams per day ingested			
6.63 g/day		= number of grams per day dry weight ingested			
Worst-Case Consumption		(EPA 1997a, General Population)			
63 g/day		= number of grams per day ingested			
16.065 g/day		= number of grams per day dry weight ingested			
Dry/Wet Weight Fraction		(Fresquez and Ferenbaugh 1998)			
0.255 unitless		= LANL dry/wet weight ratio			
Exposure Duration					
365 days		= 1 yr exposure duration			
Uranium Conversion		U=	3.51E-03	µg/g	
pCi U isotope/g = µg total uranium/g X RMA X SA X CF					
RMA = relative mass abundance (g isotope per g total U)					
SA = specific activity (pCi/g)					
CF = conversion factor (1E-06 g/µg)					
			RMA	SA	CF
U-238=	1.17E-03	pCi/g	9.93E-01	3.35E+05	1.00E-06
U-235=	5.46E-05	pCi/g	7.20E-03	2.16E+06	1.00E-06
U-234=	1.27E-03	pCi/g	5.80E-05	6.24E+09	1.00E-06
Total U Activity =	2.49E-03	pCi/g			

TABLE D.3.3–30.—Ingestion of Elk for an Off-Site Non-Los Alamos (Note: includes LANL 1990–1994 On-Site Road Kills from TA–5, TA–16, TA–18, TA–46, and TA–49, see Table D.3.5–6)

ANALYTE	95% UCL (pCi/g) dry wt.	DOSE CONVERSION FACTOR (rem/pCi)	AVERAGE- CASE DOSE (rem/year)	WORST- CASE DOSE (rem/year)	
Cesium-137	2.98E-01	5.00E-08	3.61E-05	8.74E-05	
Plutonium-238	2.00E-05	3.80E-06	1.84E-07	4.46E-07	
Plutonium-239	3.08E-04	4.30E-06	3.20E-06	7.77E-06	
Strontium-90	1.66E-02	1.30E-07	5.22E-06	1.27E-05	
Tritium ¹	6.86E+00	6.30E-11	3.06E-06	7.40E-06	
Uranium	7.67E-03	2.60E-07	4.83E-06	1.17E-05	
¹ 95% UCL concentration in % of food that is water					
			Average- Case	Worst-Case	
Total Dose (rem/yr)			5.25E-05	1.27E-04	
Cancer Risk yr-1			2.63E-08	6.37E-08	
Average-Case Consumption		(EPA 1997a, General Population)			
26 g/day		= number of grams per day ingested			
6.63 g/day		= number of grams per day dry weight ingested			
Worst-Case Consumption		(EPA 1997a, General Population)			
63 g/day		= number of grams per day ingested			
16.065 g/day		= number of grams per day dry weight ingested			
Dry/Wet Weight Fraction		(Fresquez and Ferenbaugh 1998)			
0.255 unitless		= LANL dry/wet weight ratio			
Exposure Duration					
365 days		= 1 yr exposure duration			
Tritium Conversion		H³=	6.86	pCi/mL	
pCi/g of Tritium = pCi/mL tritium X mL/g of water					
water density =	1	g/mL			
Tritium Activity =	6.86	pCi/g			
Uranium Conversion		U=	1.08E-02	µg/g	
pCi U isotope/g = µg total uranium/g X RMA X SA X CF					
RMA = relative mass abundance (g isotope per g total U)					
SA = specific activity (pCi/g)					
CF = conversion factor (1E-06 g/µg)					
			RMA	SA	CF
U-238=	3.59E-03	pCi/g	9.93E-01	3.35E+05	1.00E-06
U-235=	1.68E-04	pCi/g	7.20E-03	2.16E+06	1.00E-06
U-234=	3.91E-03	pCi/g	5.80E-05	6.24E+09	1.00E-06
Total U Activity =	7.67E-03	pCi/g			

TABLE D.3.3–31.—Ingestion of Deer for an Off-Site Los Alamos County Resident (Note: Includes Off-Site Road Kills from Cuba and El Vado, LANL 1997, see Table D.3.5–8)

ANALYTE	95% UCL (pCi/g) dry wt.	DOSE CONVERSION FACTOR (rem/pCi)	AVERAGE- CASE DOSE (rem/year)	WORST- CASE DOSE (rem/year)	
Americium-241	0.00E+00	4.50E-06	0.00E+00	0.00E+00	
Cesium-137	2.65E-02	5.00E-08	3.14E-06	7.62E-06	
Plutonium-238	4.60E-05	3.80E-06	4.15E-07	1.00E-06	
Plutonium-239	1.91E-04	4.30E-06	1.95E-06	4.72E-06	
Strontium-90	3.83E-02	1.30E-07	1.18E-05	2.86E-05	
Tritium ¹	8.60E-01	6.30E-11	1.29E-07	3.11E-07	
Uranium	1.04E-03	2.60E-07	6.40E-07	1.55E-06	
¹ 95% UCL concentration in % of food that is water					
			Average- Case	Worst-Case	
Total Dose (rem/yr)			1.81E-05	4.38E-05	
Cancer Risk yr-1			9.04E-09	2.19E-08	
Average-Case Consumption		(EPA 1997a, General Population)			
26 g/day	= number of grams per day ingested				
6.5 g/day	= number of grams per day dry weight ingested				
Worst-Case Ingestion		(EPA 1997a, General Population)			
63 g/day	= number of grams per day ingested				
15.75 g/day	= number of grams per day dry weight ingested				
Dry/Wet Weight Fraction		(Fresquez and Ferenbaugh 1998)			
0.25 unitless	= LANL dry/wet weight ratio				
Exposure Duration					
365 days	= 1 yr exposure duration				
Tritium Conversion		H³=	0.86	pCi/mL	
pCi/g of Tritium = pCi/mL tritium X mL/g of water					
water density =	1	g/mL			
Tritium Activity =	0.86	pCi/g			
Uranium Conversion		U=	1.46E-03	µg/g	
pCi U isotope/g = µg total uranium/g X RMA X SA X CF					
RMA = relative mass abundance (g isotope per g total U)					
SA = specific activity (pCi/g)					
CF = conversion factor (1E-06 g/µg)					
			RMA	SA	CF
U-238=	4.86E-04	pCi/g	9.93E-01	3.35E+05	1.00E-06
U-235=	2.27E-05	pCi/g	7.20E-03	2.16E+06	1.00E-06
U-234=	5.28E-04	pCi/g	5.80E-05	6.24E+09	1.00E-06
Total U Activity=	1.04E-03	pCi/g			

TABLE D.3.3–32.—Ingestion of Deer for an Off-Site Non-Los Alamos County Resident
 (Note: Includes LANL Road Kills from TA–8, TA–16, TA–21, and TA–55, LANL 1997,
 see Table D.3.5–8)

ANALYTE	95% UCL (pCi/g) dry wt.	DOSE CONVERSION FACTOR (rem/pCi)	AVERAGE- CASE DOSE (rem/year)	WORST- CASE DOSE (rem/year)
Americium-241	7.90E-05	4.50E-06	8.43E-07	2.04E-06
Cesium-137	5.00E-01	5.00E-08	5.93E-05	1.44E-04
Plutonium-238	5.00E-05	3.80E-06	4.51E-07	1.09E-06
Plutonium-239	5.60E-05	4.30E-06	5.71E-07	1.38E-06
Strontium-90	2.30E-02	1.30E-07	7.09E-06	1.72E-05
Tritium ¹	9.90E-01	6.30E-11	1.48E-07	3.59E-07
Uranium	4.97E-01	2.60E-07	3.07E-04	7.43E-04
¹ 95% UCL concentration in % of food that is water			Average- Case	Worst-Case
Total Dose (rem/yr)			3.75E-04	9.09E-04
Cancer Risk yr-1			1.88E-07	4.54E-07
Average-Case Consumption		(EPA 1997a, General Population)		
	26 g/day	= number of grams per day ingested		
	6.5 g/day	= number of grams per day dry weight ingested		
Worst-Case Ingestion		(EPA 1997a, General Population)		
	63 g/day	= number of grams per day ingested		
	15.75 g/day	= number of grams per day dry weight ingested		
Dry/Wet Weight Fraction		(Fresquez and Ferenbaugh 1998)		
	0.25 unitless	= LANL dry/wet weight ratio		
Exposure Duration				
	365 days	= 1 yr exposure duration		

TABLE D.3.3-32.—Ingestion of Deer for an Off-Site Non-Los Alamos County Resident
(Note: Includes LANL Road Kills from TA-8, TA-16, TA-21, and TA-55, LANL 1997, see Table D.3.5-8)-Continued

Tritium Conversion		H³=	0.99	pCi/mL	
pCi/g of Tritium = pCi/mL tritium X mL/g of water					
water density =		1		g/mL	
Tritium Activity =		0.99	pCi/g		
Uranium Conversion		U=	7.00E-01	μg/g	
pCi U isotope/g = μg total uranium/g X RMA X SA X CF					
RMA = relative mass abundance (g isotope per g total U)					
SA = specific activity (pCi/g)					
CF = conversion factor (1E-06 g/μg)					
			RMA	SA	CF
U-238=	2.33E-01	pCi/g	9.93E-01	3.35E+05	1.00E-06
U-235=	1.09E-02	pCi/g	7.20E-03	2.16E+06	1.00E-06
U-234=	2.53E-01	pCi/g	5.80E-05	6.24E+09	1.00E-06
Total U Activity =		4.97E-01	pCi/g		

TABLE D.3.3–33.—Ingestion of Fish for an Off-Site Non-Los Alamos County Resident
(Note: Includes all Game and Nongame Fish from Abiquiu and Cochiti, Foodstuffs Database 1990–1994, see Table D.3.5–9)

ANALYTE	95% UCL (pCi/g) dry wt.	DOSE CONVERSION FACTOR (rem/pCi)	AVERAGE- CASE DOSE (rem/year)	WORST- CASE DOSE (rem/year)	
Cesium-137	2.36E-01	5.00E-08	2.22E-05	6.95E-05	
Plutonium-238	8.22E-05	3.80E-06	5.87E-07	1.84E-06	
Plutonium-239	1.50E-04	4.30E-06	1.21E-06	3.80E-06	
Strontium-90	1.03E-01	1.30E-07	2.51E-05	7.88E-05	
Uranium	1.05E-02	2.60E-07	5.13E-06	1.61E-05	
			Average- Case	Worst-Case	
Total Dose (rem/yr)			5.42E-05	1.70E-04	
Cancer Risk yr-1			2.71E-08	8.50E-08	
Average-Case Consumption		(EPA 1997a, General Population)			
20.1 g/day		= number of grams per day ingested			
5.1456 g/day		= number of grams per day dry weight ingested			
Worst-Case Consumption		(EPA 1997a, General Population)			
63 g/day		= number of grams per day ingested			
16.128 g/day		= number of grams per day dry weight ingested			
Dry/Wet Weight Fraction		(Fresquez and Ferenbaugh 1998)			
0.256 unitless		= LANL dry/wet weight ratio in fish 1990–1995			
Exposure Duration					
365 days		= 1 yr exposure duration			
Uranium Conversion		U=	1.48E-02	µg/g	
pCi U isotope/g = µg total uranium/g X RMA X SA X CF					
RMA = relative mass abundance (g isotope per g total U)					
SA = specific activity (pCi/g)					
CF = conversion factor (1E-06 g/µg)					
			RMA	SA	CF
U-238=	4.92E-03	pCi/g	9.93E-01	3.35E+05	1.00E-06
U-235=	2.30E-04	pCi/g	7.20E-03	2.16E+06	1.00E-06
U-234=	5.36E-03	pCi/g	5.80E-05	6.24E+09	1.00E-06
Total U Activity =	1.05E-02	pCi/g			

TABLE D.3.3-34.—Ingestion of Metals in Bottom-Feeding Fish for an Off-Site Non-Los Alamos County Resident (Note: Includes Abiquiu, Heron, and El Vado Data, which is higher than Cochiti Data, LANL 1997, Table D.3.5-10)

ANALYTES	MEAN ¹ (µg/g-wet)	AVERAGE- CASE CHRONIC DAILY INTAKE mg/kg-day	WORST- CASE CHRONIC DAILY INTAKE mg/kg-day	ORAL RfD mg/kg-day	ORAL SLOPE FACTOR per (mg/kg)/ day	AVERAGE- CASE HAZARD INDEX	WORST- CASE HAZARD INDEX	AVERAGE- CASE CANCER RISK	WORST- CASE CANCER RISK
AG	1.25E-01	3.50E-05	1.10E-04	5.0E-03	-	7.00E-03	2.19E-02		
AS	2.50E-01	7.00E-05	2.19E-04	3.0E-04	1.5E+00	2.33E-01	7.31E-01	1.05E-04	3.29E-04
BA	6.30E-02	1.76E-05	5.53E-05	7.0E-02	-	2.52E-04	7.90E-04		
BE	5.30E-02	1.48E-05	4.65E-05	5.0E-03	4.3E+00	2.97E-03	9.30E-03	6.38E-05	2.00E-04
CD	1.14E-01	3.19E-05	1.00E-04	5.0E-04	1.8E-03	6.38E-02	2.00E-01	5.74E-08	1.80E-07
CR	6.25E-01	1.75E-04	5.48E-04	1.0E+00	-	1.75E-04	5.48E-04		
CU	8.15E-01	2.28E-04	7.15E-04	1.9E-02	-	1.20E-02	3.76E-02		
HG	3.42E-01	9.57E-05	3.00E-04	3.0E-04	-	3.19E-01	1.00E+00		
NI	1.13E+00	3.15E-04	9.87E-04	2.0E-02	-	1.57E-02	4.94E-02		
PB	1.25E+00	3.50E-04	1.10E-03	1.4E-03	no data	2.50E-01	7.83E-01		
SB	1.25E+00	3.50E-04	1.10E-03	4.0E-04	-	8.75E-01	2.74E+00		
SE	2.75E-01	7.70E-05	2.41E-04	5.0E-03	-	1.54E-02	4.83E-02		
TL	1.25E+00	3.50E-04	1.10E-03	8.0E-05	-	4.37E+00	1.37E+01		
ZN	5.78E+00	1.62E-03	5.07E-03	3.0E-01	-	5.39E-03	1.69E-02		

¹ 95% UCL Values not available for all analytes, mean values used for consistency.

Note: gray shaded cells in Slope Factor column have no known human chemical cancer risk.

Note: gray shaded cells in Carcinogenic Risk columns have no known human chemical cancer risk.

TABLE D.3.3-34.—Ingestion of Metals in Bottom-Feeding Fish for an Off-Site Non-Los Alamos County Resident (Note: Includes Abiquiu, Heron, and El Vado Data, which is higher than Cochiti Data, LANL 1997, Table D.3.5-10)—Continued

Average-Case Ingestion	(EPA 1997a, General Population)
20.1 g/day	= number of grams per day ingested
5.1456 g/day	= number of grams per day dry weight ingested
Worst-Case Ingestion	(EPA 1997a, General Population)
63 g/day	= number of grams per day ingested
16.128 g/day	= number of grams per day dry weight ingested
Dry/Wet Weight Fraction	(Fresquez and Ferenbaugh 1998)
0.256 unitless	= LANL dry/wet weight ratio in fish 1990-1995
Unit Conversion Factor	1.00E-03 mg/ μ g = number of milligrams per microgram
Average Man Weight	71.8 kg = number of kg for an average man

TABLE D.3.3–35.—Ingestion of Fruits and Vegetables for Off-Site Los Alamos County Residents
 (Note: Includes Los Alamos and White Rock Data for Homegrown and Regional Data for Store-Bought, Foodstuffs Database 1990–1994, see Table D.3.5–6)

ANALYTE	HOMEGROWN 95% UCL (pCi/g)	STORE-BOUGHT 95% UCL (pCi/g)	DOSE CONVERSION FACTOR (rem/pCi)	AVERAGE- CASE DOSE (rem/year)	WORST-CASE DOSE (rem/year)
FRUITS					
Cesium-137	4.87E-01	2.67E-01	5.00E-08	2.08E-04	8.12E-04
Plutonium-238	9.69E-04	4.15E-04	3.80E-06	2.67E-05	1.08E-04
Plutonium-239	9.87E-03	6.50E-04	4.30E-06	1.43E-04	7.16E-04
Strontium-90	1.22E-01	7.30E-02	1.30E-07	1.44E-04	5.56E-04
Tritium ¹	9.14E+00	9.34E-01	6.30E-11	1.23E-05	5.91E-05
Uranium	3.20E-02	2.88E-02	2.60E-07	1.02E-04	3.77E-04
VEGETABLES					
Cesium-137	4.40E-01	3.47E-01	5.00E-08	3.13E-04	7.55E-04
Plutonium-238	6.46E-04	4.22E-04	3.80E-06	3.07E-05	7.64E-05
Plutonium-239	7.59E-03	1.17E-03	4.30E-06	2.02E-04	6.32E-04
Strontium-90	3.41E-01	1.06E-01	1.30E-07	3.62E-04	1.02E-03
Tritium ¹	1.13E+00	7.91E-01	6.30E-11	5.28E-06	1.30E-05
Uranium	8.02E-03	1.89E-02	2.60E-07	7.11E-05	1.49E-04
¹ 95% UCL concentration in % of food that is water					
		Fruit	Fruit	Vegetables	Vegetables
		Average-Case	Worst-Case	Average-Case	Worst-Case
Total Dose (rem/yr)		6.36E-04	2.63E-03	9.84E-04	2.65E-03
Cancer Risk yr-1		3.18E-07	1.31E-06	4.92E-07	1.32E-06
Average-Case Consumption		(EPA 1997a, Table 9-3; 9-4)			
	3.40 g/kg-day	= grams of fruit ingested per day per kg body wt.			
	0.15 fraction	= % of grams of fruit ingested per day as dry-wt.			
	0.20 fraction	= % homegrown (EPA 1989)			
	4.30 g/kg-day	= grams of vegetables ingested per day per kg body wt.			
	0.15 fraction	= % of grams of vegetables ingested per day as dry-wt.			
	0.25 fraction	= % homegrown (EPA 1989)			
Worst-Case Consumption		(EPA 1997a, Table 9-3; 9-4)			
	12.40 g/kg-day	= grams of fruit ingested per day per kg body wt.			
	0.15 fraction	= % of grams of fruit ingested per day as dry-wt.			
	0.30 fraction	= % homegrown (EPA 1989)			
	10.00 g/kg-day	= grams of vegetables ingested per day per kg body wt.			
	0.15 fraction	= % of grams of vegetables ingested per day as dry-wt.			
	0.40 fraction	= % homegrown (EPA 1989)			

TABLE D.3.3–35.—Ingestion of Fruits and Vegetables for Off-Site Los Alamos County Residents
 (Note: Includes Los Alamos and White Rock Data for Homegrown and Regional Data for Store-Bought, Foodstuffs Database 1990–1994, see Table D.3.5–6)-Continued

Exposure Duration					
365 days		= 1 yr exposure duration			
(Note: Dry weight fractions are from Fresquez and Ferenbaugh 1998.)					
Fruit Tritium Conversion					
HG		SB		HG H³=	9.14 pCi/mL
pCi/g of Tritium = pCi/mL tritium X mL/g of water				SB H³=	9.34E-01 pCi/mL
water density =	1	1		g/mL	
Tritium Activity = 9.14		0.934		pCi/g	
Vegetable Tritium Conversion					
HG		SB		HG H³=	1.13 pCi/mL
pCi/g of Tritium = pCi/mL tritium X mL/g of water				SB H³=	7.91E-01 pCi/mL
water density =	1	1		g/mL	
Tritium Activity = 1.13		0.791		pCi/g	
Fruit Uranium Conversion					
				HG U=	4.50E-02 µg/g
				SB U=	4.06E-02 µg/g
pCi U isotope/g fruit = µg total uranium/g fruit X RMA X SA X CF					
RMA = relative mass abundance (g isotope per g total U)					
SA = specific activity (pCi/g)					
CF = conversion factor (1E-06 g/µg)					
	Homegrown	Store-Bought	RMA	SA	CF
U-238=	1.50E-02	1.35E-02	9.93E-01	3.35E+05	1.00E-06
U-235=	7.00E-04	6.31E-04	7.20E-03	2.16E+06	1.00E-06
U-234=	1.63E-02	1.47E-02	5.80E-05	6.24E+09	1.00E-06
Total U Activity = 3.20E-02		2.88E-02		pCi/g	
Vegetable Uranium Conversion					
				HG U=	1.13E-02 µg/g
				SB U=	2.66E-02 µg/g
pCi U isotope/g vegetable = µg total uranium/g vegetable X RMA X SA X CF					
RMA = relative mass abundance (g isotope per g total U)					
SA = specific activity (pCi/g)					
CF = conversion factor (1E-06 g/µg)					
	Homegrown	Store-Bought	RMA	SA	CF
U-238=	3.76E-03	8.85E-03	9.93E-01	3.35E+05	1.00E-06
U-235=	1.76E-04	4.14E-04	7.20E-03	2.16E+06	1.00E-06
U-234=	4.09E-03	9.63E-03	5.80E-05	6.24E+09	1.00E-06
Total U Activity = 8.02E-03		1.89E-02		pCi/g	

TABLE D.3.3–35.—Ingestion of Fruits and Vegetables for Off-Site Los Alamos County Residents
(Note: Includes Los Alamos and White Rock Data for Homegrown and Regional Data for Store-Bought, Foodstuffs Database 1990–1994, see Table D.3.5–6)-Continued

Intermediate Step Calculation (Assumes a body wt. of 71.8 kg)				
Fruit	HG	SB	HG	SB
	Average-Case Dose (rem/year)	Average-Case Dose (rem/year)	Worst-Case Dose (rem/year)	Worst-Case Dose (rem/year)
Cesium-137	6.51E-05	1.43E-04	3.56E-04	4.56E-04
Plutonium-238	9.84E-06	1.69E-05	5.38E-05	5.38E-05
Plutonium-239	1.13E-04	2.99E-05	6.21E-04	9.54E-05
Strontium-90	4.24E-05	1.01E-04	2.32E-04	3.24E-04
Tritium ¹	8.72E-06	3.57E-06	4.77E-05	1.14E-05
Uranium	2.22E-05	8.02E-05	1.21E-04	2.56E-04
Vegetables	HG	SB	HG	SB
	Average-Case Dose (rem/year)	Average-Case Dose (rem/year)	Worst-Case Dose (rem/year)	Worst-Case Dose (rem/year)
Cesium-137	9.30E-05	2.20E-04	3.46E-04	4.09E-04
Plutonium-238	1.04E-05	2.03E-05	3.86E-05	3.78E-05
Plutonium-239	1.38E-04	6.38E-05	5.13E-04	1.19E-04
Strontium-90	1.87E-04	1.75E-04	6.97E-04	3.25E-04
Tritium ¹	1.70E-06	3.58E-06	6.34E-06	6.66E-06
Uranium	8.82E-06	6.23E-05	3.28E-05	1.16E-04

**TABLE D.3.3–36.—Ingestion of Metals in Homegrown Vegetables for Off-Site Los Alamos County Residents
(Note: Includes Los Alamos, White Rock, and Pajarito Acres, LANL 1997, see Table D.3.5–11)**

ANALYTES	95% UCL ($\mu\text{g/g-dry}$)	AVERAGE-CASE		WORST-CASE CHRONIC DAILY INTAKE mg/kg-day	ORAL SLOPE FACTOR per (mg/kg/day)	AVERAGE-CASE HAZARD INDEX		WORST-CASE HAZARD INDEX		WORST-CASE CANCER RISK
		CHRONIC DAILY INTAKE mg/kg-day	ORAL RfD mg/kg-day			HAZARD INDEX	HAZARD INDEX	HAZARD INDEX	CANCER RISK	
AG	5.40E-01	8.71E-05	3.24E-04	5.0E-03	-	1.74E-02	6.48E-02	2.00E-01	2.42E-05	9.00E-05
AS	1.00E-01	1.61E-05	6.00E-05	3.0E-04	1.5E+00	5.38E-02	2.14E-01	7.20E-03	4.16E-05	1.55E-04
BA	2.50E+01	4.03E-03	1.50E-02	7.0E-02	-	5.76E-02	1.44E-01	1.50E-03	3.48E-08	1.30E-07
BE	6.00E-02	9.68E-06	3.60E-05	5.0E-03	4.3E+00	1.94E-03	1.44E-01	1.00E-01		
CD	1.20E-01	1.94E-05	7.20E-05	5.0E-04	1.8E-03	3.87E-02	1.50E-03	5.10E-01		
CR	2.50E+00	4.03E-04	1.50E-03	1.0E+00	-	4.03E-04	1.67E+01			
HG	5.00E-02	8.06E-06	3.00E-05	3.0E-04	-	2.69E-02	5.85E-01			
NI	1.70E+01	2.74E-03	1.02E-02	2.0E-02	-	1.37E-01	5.28E-02			
PB	3.90E+01	6.29E-03	2.34E-02	1.4E-03	no data	4.49E+00	1.13E+00			
SB	3.90E-01	6.29E-05	2.34E-04	4.0E-04	-	1.57E-01				
SE	4.40E-01	7.10E-05	2.64E-04	5.0E-03	-	1.42E-02				
TL	1.50E-01	2.42E-05	9.00E-05	8.0E-05	-	3.02E-01				

Note: gray shaded cells in Slope Factor column have no known human chemical cancer risk.

Note: gray shaded cells in Carcinogenic Risk columns have no known human chemical cancer risk.

TABLE D.3.3-36.—Ingestion of Metals in Homegrown Vegetables for Off-Site Los Alamos County Residents
(Note: Includes Los Alamos, White Rock, and Pajarito Acres, LANL 1997, see Table D.3.5-11)-Continued

Average-Case Ingestion	
4.3 g/kg-day	(EPA 1997a, Table 9-3; 9-4) = number of grams of vegetables ingested per day per kg body wt.
0.15 fraction	= % of grams of vegetables ingested per day as dry-wt. (Fresquez and Ferenbaugh 1998)
0.25 fraction	= % homegrown (EPA 1989)
Worst-Case Ingestion	
10 g/kg-day	(EPA 1997a, Table 9-3; 9-4) = number of grams of vegetables ingested per day per kg body wt.
0.15 fraction	= % of grams of vegetables ingested per day as dry-wt. (Fresquez and Ferenbaugh 1998)
0.4 fraction	= % homegrown (EPA 1989)
Units Conversion	
1.00E-03 mg/μg	= number of milligrams per microgram

TABLE D.3.3-37.—Ingestion of Metals in Store Bought Vegetables for Off-Site Los Alamos and Non-Los Alamos County Residents (Note: Includes Española, Santa Fe, Jemez, Cochiti, Peña Blanca, Santo Domingo, LANL 1997, see Table D.3.5-11)-Continued

Average-Case Ingestion	(EPA 1997a, Table 9-3; 9-4)
4.3 g/kg-day	= number of grams of vegetables ingested per day per kg body wt.
0.15 fraction	= % of grams of vegetables ingested per day as dry-wt. (Fresquez and Ferenbaugh 1998)
0.75 fraction	= % homegrown (EPA 1989)
Worst-Case Ingestion	(EPA 1997a, Table 9-3; 9-4)
10 g/kg-day	= number of grams of vegetables ingested per day per kg body wt.
0.15 fraction	= % of grams of vegetables ingested per day as dry-wt. (Fresquez and Ferenbaugh 1998)
0.6 fraction	= % homegrown (EPA 1989)
Units Conversion	
1.00E-03 mg/μg	= number of milligrams per microgram

TABLE D.3.3-38.—Ingestion of Metals in Homegrown Fruit for Off-Site Los Alamos County Residents
(Note: Includes Los Alamos Townsite Data, LANL 1997, see Table D.3.5-11)

ANALYTES	95% UCL ($\mu\text{g/g-dry}$)	AVERAGE-CASE		WORST-CASE		ORAL SLOPE FACTOR per (mg/kg)/ day	AVERAGE- CASE HAZARD INDEX		WORST- CASE HAZARD INDEX		AVERAGE- CASE CANCER RISK		WORST- CASE CANCER RISK	
		CHRONIC DAILY INTAKE mg/kg-day	CHRONIC DAILY INTAKE mg/kg-day	CHRONIC DAILY INTAKE mg/kg-day	CHRONIC DAILY INTAKE mg/kg-day		ORAL RfD mg/kg-day	HAZARD INDEX	HAZARD INDEX	HAZARD INDEX	HAZARD INDEX	CANCER RISK	CANCER RISK	CANCER RISK
AG	8.60E-01	8.77E-05	4.80E-04	5.0E-03	5.0E-03	-	1.75E-02	9.60E-02	1.53E-05	8.37E-05	1.53E-05	8.37E-05	1.53E-05	8.37E-05
AS	1.00E-01	1.02E-05	5.58E-05	3.0E-04	3.0E-04	1.5E+00	3.40E-02	1.86E-01	1.53E-05	8.37E-05	1.53E-05	8.37E-05	1.53E-05	8.37E-05
BA	2.60E+00	2.65E-04	1.45E-03	7.0E-02	7.0E-02	-	3.79E-03	2.07E-02	2.63E-05	1.44E-04	2.63E-05	1.44E-04	2.63E-05	1.44E-04
BE	6.00E-02	6.12E-06	3.35E-05	5.0E-03	5.0E-03	4.3E+00	1.22E-03	6.70E-03	2.20E-08	1.21E-07	2.20E-08	1.21E-07	2.20E-08	1.21E-07
CD	1.20E-01	1.22E-05	6.70E-05	5.0E-04	5.0E-04	1.8E-03	2.45E-02	1.34E-01	2.20E-08	1.21E-07	2.20E-08	1.21E-07	2.20E-08	1.21E-07
CR	2.40E+00	2.45E-04	1.34E-03	1.0E+00	1.0E+00	-	2.45E-04	1.34E-03	2.20E-08	1.21E-07	2.20E-08	1.21E-07	2.20E-08	1.21E-07
HG	5.00E-02	5.10E-06	2.79E-05	3.0E-04	3.0E-04	-	1.70E-02	9.30E-02	2.20E-08	1.21E-07	2.20E-08	1.21E-07	2.20E-08	1.21E-07
NI	7.20E+00	7.34E-04	4.02E-03	2.0E-02	2.0E-02	-	3.67E-02	2.01E-01	2.20E-08	1.21E-07	2.20E-08	1.21E-07	2.20E-08	1.21E-07
PB	3.80E+00	3.88E-04	2.12E-03	1.4E-03	1.4E-03	no data	2.77E-01	1.51E+00	2.20E-08	1.21E-07	2.20E-08	1.21E-07	2.20E-08	1.21E-07
SB	1.50E-01	1.53E-05	8.37E-05	4.0E-04	4.0E-04	-	3.83E-02	2.09E-01	2.20E-08	1.21E-07	2.20E-08	1.21E-07	2.20E-08	1.21E-07
SE	1.00E-01	1.02E-05	5.58E-05	5.0E-03	5.0E-03	-	2.04E-03	1.12E-02	2.20E-08	1.21E-07	2.20E-08	1.21E-07	2.20E-08	1.21E-07
TL	1.50E-01	1.53E-05	8.37E-05	8.0E-05	8.0E-05	-	1.91E-01	1.05E+00	2.20E-08	1.21E-07	2.20E-08	1.21E-07	2.20E-08	1.21E-07

Note: gray shaded cells in Slope Factor column have no known human chemical cancer risk.

Note: gray shaded cells in Carcinogenic Risk columns have no known human chemical cancer risk.

TABLE D.3.3-38.—Ingestion of Metals in Homegrown Fruit for Off-Site Los Alamos County Residents
(Note: Includes Los Alamos Townsite Data, LANL 1997, see Table D.3.5-11)-Continued

Average-Case Ingestion	(EPA 1997a, Table 9-3; 9-4)
3.4 g/kg-day	= number of grams of fruit ingested per day per kg body wt.
0.15 fraction	= % of grams of fruit ingested per day as dry-wt. (Fresquez and Ferenbaugh 1998)
0.2 fraction	= % homegrown (EPA 1989)
Worst-Case Ingestion	(EPA 1997a, Table 9-3; 9-4)
12.4 g/kg-day	= number of grams of fruit ingested per day per kg body wt.
0.15 fraction	= % of grams of fruit ingested per day as dry-wt. (Fresquez and Ferenbaugh 1998)
0.3 fraction	= % homegrown (EPA 1989)
Units Conversion	
1.00E-03 mg/μg	= number of milligrams per microgram

TABLE D.3.3–39.—Ingestion of Fruits and Vegetables for Off-Site Non-Los Alamos County Residents (Note: Includes San Ildefonso Data for Homegrown and Regional Data for Store-Bought, Foodstuffs Database 1990–1994, see Table D.3.5–6)

ANALYTE	HOMEGROWN 95% UCL (pCi/g)	STORE- BOUGHT 95% UCL (pCi/g)	DOSE CONVERSION FACTOR (rem/pCi)	AVERAGE- CASE DOSE (rem/year)	WORST- CASE DOSE (rem/year)
FRUITS					
Cesium-137	1.81E-01	2.67E-01	5.00E-08	1.67E-04	5.88E-04
Plutonium-238	2.12E-04	4.15E-04	3.80E-06	1.90E-05	6.56E-05
Plutonium-239	1.79E-03	6.50E-04	4.30E-06	5.05E-05	2.08E-04
Strontium-90	8.41E-02	7.30E-02	1.30E-07	1.31E-04	4.84E-04
Tritium ¹	7.57E-01	9.34E-01	6.30E-11	4.29E-06	1.53E-05
Uranium	5.52E-03	2.88E-02	2.60E-07	8.40E-05	2.77E-04
VEGETABLES					
Cesium-137	1.99E+00	3.47E-01	5.00E-08	6.40E-04	1.97E-03
Plutonium-238	2.80E-03	4.22E-04	3.80E-06	6.53E-05	2.05E-04
Plutonium-239	7.92E-04	1.17E-03	4.30E-06	7.82E-05	1.72E-04
Strontium-90	2.83E-01	1.06E-01	1.30E-07	3.30E-04	9.04E-04
Tritium ¹	1.14E+00	7.91E-01	6.30E-11	5.30E-06	1.31E-05
Uranium	1.41E-01	1.89E-02	2.60E-07	2.17E-04	6.91E-04
¹ 95% UCL concentration in % of food that is water					
		Fruit	Fruit	Vegetables	Vegetables
		Average-Case	Worst-Case	Average-Case	Worst-Case
Total Dose (rem/yr)		4.55E-04	1.64E-03	1.34E-03	3.96E-03
Cancer Risk yr-1		2.28E-07	8.19E-07	6.68E-07	1.98E-06
Average-Case Consumption		(EPA 1997a, Table 9-3; 9-4)			
	3.40 g/kg-day	= grams of fruit ingested per day per kg body wt.			
	0.15 fraction	= % of grams of fruit ingested per day as dry-wt.			
	0.20 fraction	= % homegrown (EPA 1989)			
	4.30 g/kg-day	= grams of vegetables ingested per day per kg body wt.			
	0.15 fraction	= % of grams of vegetables ingested per day as dry-wt.			
	0.25 fraction	= % homegrown (EPA 1989)			
Worst-Case Consumption		(EPA 1997a, Table 9-3; 9-4)			
	12.40 g/kg-day	= grams of fruit ingested per day per kg body wt.			
	0.15 fraction	= % of grams of fruit ingested per day as dry-wt.			
	0.30 fraction	= % homegrown (EPA 1989)			
	10.00 g/kg-day	= grams of vegetables ingested per day per kg body wt.			
	0.15 fraction	= % of grams of vegetables ingested per day as dry-wt.			
	0.40 fraction	= % homegrown (EPA 1989)			

TABLE D.3.3-39.—Ingestion of Fruits and Vegetables for Off-Site Non-Los Alamos County Residents (Note: Includes San Ildefonso Data for Homegrown and Regional Data for Store-Bought, Foodstuffs Database 1990-1994, see Table D.3.5-6)-Continued

Exposure Duration					
365 days		= 1 yr exposure duration			
(Note: Dry weight fractions are from Fresquez and Ferenbaugh 1998.)					
Fruit Tritium Conversion					
HG		SB		HG H³=	7.57E-01 pCi/mL
pCi/g of Tritium = pCi/mL tritium X mL/g of water				SB H³=	9.34E-01 pCi/mL
water density =		1	1	g/mL	
Tritium Activity =		0.757	0.934	pCi/g	
Vegetable Tritium Conversion					
HG		SB		HG H³=	1.14 pCi/mL
pCi/g of Tritium = pCi/mL tritium X mL/g of water				SB H³=	7.91E-01 pCi/mL
water density =		1	1	g/mL	
Tritium Activity =		1.14	0.791	pCi/g	
Fruit Uranium Conversion				HG U=	7.78E-03 µg/g
				SB U=	4.06E-02 µg/g
pCi U isotope/g fruit = µg total uranium/g fruit X RMA X SA X CF					
RMA = relative mass abundance (g isotope per g total U)					
SA = specific activity (pCi/g)					
CF = conversion factor (1E-06 g/µg)					
	Homegrown	Store-Bought	RMA	SA	CF
U-238=	2.59E-03	1.35E-02	9.93E-01	3.35E+05	1.00E-06
U-235=	1.21E-04	6.31E-04	7.20E-03	2.16E+06	1.00E-06
U-234=	2.82E-03	1.47E-02	5.80E-05	6.24E+09	1.00E-06
Total U Activity =		5.52E-03	2.88E-02	pCi/g	
Vegetable Uranium Conversion				HG U=	1.98E-01 µg/g
				SB U=	2.66E-02 µg/g
pCi U isotope/g vegetable = µg total uranium/g vegetable X RMA X SA X CF					
RMA = relative mass abundance (g isotope per g total U)					
SA = specific activity (pCi/g)					
CF = conversion factor (1E-06 g/µg)					
	Homegrown	Store-Bought	RMA	SA	CF
U-238=	6.59E-02	8.85E-03	9.93E-01	3.35E+05	1.00E-06
U-235=	3.08E-03	4.14E-04	7.20E-03	2.16E+06	1.00E-06
U-234=	7.17E-02	9.63E-03	5.80E-05	6.24E+09	1.00E-06
Total U Activity =		1.41E-01	1.89E-02	pCi/g	

TABLE D.3.3–39.—Ingestion of Fruits and Vegetables for Off-Site Non-Los Alamos County Residents (Note: Includes San Ildefonso Data for Homegrown and Regional Data for Store-Bought, Foodstuffs Database 1990–1994, see Table D.3.5–6)-Continued

Intermediate Step Calculation		Body wt. kg = 71.8		
Fruit	HG	SB	HG	SB
	Average-Case Dose (rem/year)	Average-Case Dose (rem/year)	Worst-Case Dose (rem/year)	Worst-Case Dose (rem/year)
Cesium-137	2.42E-05	1.43E-04	1.32E-04	4.56E-04
Plutonium-238	2.15E-06	1.69E-05	1.18E-05	5.38E-05
Plutonium-239	2.06E-05	2.99E-05	1.13E-04	9.54E-05
Strontium-90	2.92E-05	1.01E-04	1.60E-04	3.24E-04
Tritium ¹	7.22E-07	3.57E-06	3.95E-06	1.14E-05
Uranium	3.84E-06	8.02E-05	2.10E-05	2.56E-04
Vegetables	HG	SB	HG	SB
	Average-Case Dose (rem/year)	Average-Case Dose (rem/year)	Worst-Case Dose (rem/year)	Worst-Case Dose (rem/year)
Cesium-137	4.20E-04	2.20E-04	1.56E-03	4.09E-04
Plutonium-238	4.50E-05	2.03E-05	1.67E-04	3.78E-05
Plutonium-239	1.44E-05	6.38E-05	5.36E-05	1.19E-04
Strontium-90	1.55E-04	1.75E-04	5.78E-04	3.25E-04
Tritium ¹	1.72E-06	3.58E-06	6.40E-06	6.66E-06
Uranium	1.54E-04	6.23E-05	5.75E-04	1.16E-04

**TABLE D.3.3-40.—Ingestion of Metals in Homegrown Vegetables for Off-Site Non-Los Alamos County Residents
(Note: Includes Los Alamos, White Rock, and Pajarito Acres, LANL 1997, see Table D.3.5-II)**

ANALYTES	95% UCL ($\mu\text{g/g-dry}$)	AVERAGE- CASE CHRONIC DAILY INTAKE mg/kg-day	WORST- CASE CHRONIC DAILY INTAKE mg/kg-day	ORAL RfD mg/kg-day	ORAL SLOPE FACTOR per (mg/kg)/ day	AVERAGE- CASE HAZARD INDEX	WORST- CASE HAZARD INDEX	AVERAGE- CASE CANCER RISK	WORST- CASE CANCER RISK
AG	1.60E-01	2.58E-05	9.60E-05	5.0E-03	-	5.16E-03	1.92E-02		
AS	4.20E-01	6.77E-05	2.52E-04	3.0E-04	1.5E+00	2.26E-01	8.40E-01	1.02E-04	3.78E-04
BA	3.60E+01	5.81E-03	2.16E-02	7.0E-02	-	8.29E-02	3.09E-01		
BE	6.00E-02	9.68E-06	3.60E-05	5.0E-03	4.3E+00	1.94E-03	7.20E-03	4.16E-05	1.55E-04
CD	1.20E-01	1.94E-05	7.20E-05	5.0E-04	1.8E-03	3.87E-02	1.44E-01	3.48E-08	1.30E-07
CR	4.60E-01	7.42E-05	2.76E-04	1.0E+00	-	7.42E-05	2.76E-04		
HG	1.00E-01	1.61E-05	6.00E-05	3.0E-04	-	5.38E-02	2.00E-01		
NI	4.10E+00	6.61E-04	2.46E-03	2.0E-02	-	3.31E-02	1.23E-01		
PB	3.00E+01	4.84E-03	1.80E-02	1.4E-03	no data	3.46E+00	1.29E+01		
SB	1.50E-01	2.42E-05	9.00E-05	4.0E-04	-	6.05E-02	2.25E-01		
SE	7.80E-01	1.26E-04	4.68E-04	5.0E-03	-	2.52E-02	9.36E-02		
TL	1.50E-01	2.42E-05	9.00E-05	8.0E-05	-	3.02E-01	1.13E+00		

Note: gray shaded cells in Slope Factor column have no known human chemical cancer risk.

Note: gray shaded cells in Carcinogenic Risk columns have no known human chemical cancer risk.

**TABLE D.3.3-40.—Ingestion of Metals in Homegrown Vegetables for Off-Site Non-Los Alamos County Residents
(Note: Includes Los Alamos, White Rock, and Pajarito Acres, LANL 1997, see Table D.3.5-11)-Continued**

Average-Case Ingestion	(EPA 1997a, Table 9-3; 9-4)
4.3 g/kg-day	= number of grams of vegetables ingested per day per kg body wt.
0.15 fraction	= % of grams of vegetables ingested per day as dry-wt. (Fresquez and Ferenbaugh 1998)
0.25 fraction	= % homegrown (EPA 1989)
Worst-Case Ingestion	(EPA 1997a Table 9-3; 9-4)
10 g/kg-day	= number of grams of vegetables ingested per day per kg body wt.
0.15 fraction	= % of grams of vegetables ingested per day as dry-wt. (Fresquez and Ferenbaugh 1998)
0.4 fraction	= % homegrown (EPA 1989)
Units Conversion	
1.00E-03 mg/μg	= number of milligrams per microgram

TABLE D.3.3-41.—Ingestion of Milk for Off-Site Residents (Note: Includes Albuquerque Data for Los Alamos County and Nambe Data for Non-Los Alamos County Resident, Foodstuffs Database 1990–1994, see Table D.3.5–6)

ANALYTE	MEAN ¹ (pCi/L)	DOSE CONVERSION FACTOR (rem/pCi)	AVERAGE- CASE DOSE (rem/year)	WORST- CASE DOSE (rem/year)
LOS ALAMOS COUNTY				
Cesium-137	2.41E+00	5.00E-08	1.32E-05	3.52E-05
Iodine-131	1.00E+01	5.30E-08	5.80E-05	1.55E-04
Plutonium-238	0.00E+00	3.80E-06	0.00E+00	0.00E+00
Plutonium-239	0.00E+00	4.30E-06	0.00E+00	0.00E+00
Strontium-90	0.00E+00	1.30E-07	0.00E+00	0.00E+00
Tritium	0.00E+00	6.30E-11	0.00E+00	0.00E+00
Uranium	7.10E-02	2.60E-07	2.02E-06	5.39E-06
NON-LOS ALAMOS COUNTY				
Cesium-137	3.10E+00	5.00E-08	1.70E-05	4.53E-05
Iodine-131	4.70E+00	5.30E-08	2.73E-05	7.27E-05
Plutonium-238	3.00E-03	3.80E-06	1.25E-06	3.33E-06
Plutonium-239	0.00E+00	4.30E-06	0.00E+00	0.00E+00
Strontium-90	0.00E+00	1.30E-07	0.00E+00	0.00E+00
Tritium	1.00E+02	6.30E-11	6.90E-07	1.84E-06
Uranium	1.70E-01	2.60E-07	4.85E-06	1.29E-05
¹ 95% UCL concentration not available, value not converted from % moisture or dry/wet weight				

	LOS ALAMOS COUNTY	LOS ALAMOS COUNTY	NON- LOS ALAMOS COUNTY	NON-LOS ALAMOS COUNTY
	Average-Case	Worst-Case	Average-Case	Worst-Case
Total Dose (rem/yr)	7.33E-05	1.95E-04	5.10E-05	1.36E-04
Cancer Risk yr-1	3.66E-08	9.77E-08	2.55E-08	6.81E-08
Average-Case Consumption	(EPA 1997a, Table 3-26, pg. 3-23)			
0.30 L/day	= number of liters of milk ingested per day			
Worst-Case Consumption	(EPA 1997a, Table 3-26, pg. 3-23)			
0.80 L/day	= number of liters of milk ingested per day			
	(NOTE: assumes pregnant woman ingestion rate)			
Exposure Duration				
365 days	= 1 yr exposure duration			

TABLE D.3.3–41.—Ingestion of Milk for Off-Site Residents (Note: Includes Albuquerque Data for Los Alamos County and Nambe Data for Non-Los Alamos County Resident, Foodstuffs Database 1990–1994, see Table D.3.5–6)-Continued

Los Alamos County Uranium Conversion			U=	1.00E-01	µg/L
pCi U isotope/L milk = µg total uranium/L milk X RMA X SA X CF					
RMA = relative mass abundance (g isotope per g total U)					
SA = specific activity (pCi/g)					
CF = conversion factor (1E-06 g/µg)					
			RMA	SA	CF
U-238=	3.33E-02	pCi/L	9.93E-01	3.35E+05	1.00E-06
U-235=	1.56E-03	pCi/L	7.20E-03	2.16E+06	1.00E-06
U-234=	3.62E-02	pCi/L	5.80E-05	6.24E+09	1.00E-06
Total U Activity =	7.10E-02	pCi/L			
Non-Los Alamos County Uranium Conversion			U=	2.40E-01	µg/L
pCi U isotope/L milk = µg total uranium/L milk X RMA X SA X CF					
RMA = relative mass abundance (g isotope per g total U)					
SA = specific activity (pCi/g)					
CF = conversion factor (1E-06 g/µg)					
			RMA	SA	CF
U-238=	7.98E-02	pCi/L	9.93E-01	3.35E+05	1.00E-06
U-235=	3.73E-03	pCi/L	7.20E-03	2.16E+06	1.00E-06
U-234=	8.69E-02	pCi/L	5.80E-05	6.24E+09	1.00E-06
Total U Activity =	1.70E-01	pCi/L			

TABLE D.3.3-42.—Ingestion of Fish for a Special Pathway Receptor (Note: Includes all Game and Nongame Fish from Abiquiu and Cochiti, Foodstuffs Database 1990–1994, see Table D.3.5-9)

ANALYTE	95% UCL (pCi/g) dry wt.	DOSE CONVERSION FACTOR (rem/pCi)	AVERAGE- CASE DOSE (rem/year)	WORST-CASE DOSE (rem/year)
Cesium-137	2.36E-01	5.00E-08	7.72E-05	1.87E-04
Plutonium-238	8.22E-05	3.80E-06	2.04E-06	4.96E-06
Plutonium-239	1.50E-04	4.30E-06	4.22E-06	1.02E-05
Strontium-90	1.03E-01	1.30E-07	8.76E-05	2.13E-04
Uranium	1.05E-02	2.60E-07	1.79E-05	4.34E-05
			Average-Case	Worst-Case
Total Dose (rem/yr)			1.89E-04	4.59E-04
Cancer Risk yr-1			9.44E-08	2.29E-07
Average-Case Consumption		(EPA 1997a, Native American Subsistence)		
	70 g/day	= number of grams per day ingested		
	17.92 g/day	= number of grams per day dry weight ingested		
Worst-Case Consumption		(EPA 1997a, Native American Subsistence)		
	170 g/day	= number of grams per day ingested		
	43.52 g/day	= number of grams per day dry weight ingested		
Dry/Wet Weight Fraction		(Fresquez and Ferenbaugh 1998)		
	0.256 unitless	= LANL dry/wet weight ratio in fish 1990–1995		
Exposure Duration				
	365 days	= 1 yr exposure duration		
Uranium Conversion		U=	1.48E-02	µg/g
pCi U isotope/g = µg total uranium/g X RMA X SA X CF				
RMA = relative mass abundance (g isotope per g total U)				
SA = specific activity (pCi/g)				
CF = conversion factor (1E-06 g/µg)				
			RMA	SA
				CF
U-238=	4.92E-03	pCi/g	9.93E-01	3.35E+05
U-235=	2.30E-04	pCi/g	7.20E-03	2.16E+06
U-234=	5.36E-03	pCi/g	5.80E-05	6.24E+09
Total U Activity =	1.05E-02	pCi/g		

TABLE D.3.3-43.—Ingestion of Metals in Bottom-Feeding Fish for a Special Pathway Receptor
 (Note: Uses Regional Statistical Reference Level (RSRL) Data, LANL 1997, see Table D.3.5-12)

ANALYTES	95% UCL (µg/g-wet)	AVERAGE- CASE		WORST- CASE CHRONIC DAILY INTAKE mg/kg-day	ORAL RfD mg/kg-day	ORAL SLOPE FACTOR per (mg/kg)/ day	AVERAGE- CASE		WORST- CASE HAZARD INDEX	AVERAGE- CASE		WORST- CASE HAZARD INDEX	AVERAGE- CASE		WORST- CASE HAZARD INDEX
		CHRONIC DAILY INTAKE mg/kg-day	CHRONIC DAILY INTAKE mg/kg-day				HAZARD INDEX	HAZARD INDEX		HAZARD INDEX	HAZARD INDEX				
AG	1.20E+00	1.17E-03	2.84E-03	5.0E-03	-	2.34E-01	5.68E-01	2.34E-01	5.68E-01	5.85E-04	5.85E-04	5.85E-04	5.85E-04	5.85E-04	1.42E-03
AS	4.00E-01	3.90E-04	9.47E-04	3.0E-04	1.5E+00	1.30E+00	3.16E+00	1.30E+00	3.16E+00	5.85E-04	5.85E-04	5.85E-04	5.85E-04	5.85E-04	1.42E-03
BA	1.20E+00	1.17E-03	2.84E-03	7.0E-02	-	1.67E-02	4.06E-02	1.67E-02	4.06E-02	5.85E-04	5.85E-04	5.85E-04	5.85E-04	5.85E-04	1.42E-03
BE	1.30E+00	1.27E-03	3.08E-03	5.0E-03	4.3E+00	2.53E-01	6.16E-01	2.53E-01	6.16E-01	5.45E-03	5.45E-03	5.45E-03	5.45E-03	5.45E-03	1.32E-02
CD	3.00E-01	2.92E-04	7.10E-04	5.0E-04	1.8E-03	5.85E-01	1.42E+00	5.85E-01	1.42E+00	5.26E-07	5.26E-07	5.26E-07	5.26E-07	5.26E-07	1.28E-06
CR	1.50E+00	1.46E-03	3.55E-03	1.0E+00	-	1.46E-03	3.55E-03	1.46E-03	3.55E-03	5.85E-04	5.85E-04	5.85E-04	5.85E-04	5.85E-04	1.42E-03
CU	1.40E+00	1.36E-03	3.31E-03	1.9E-02	-	7.18E-02	1.74E-01	7.18E-02	1.74E-01	5.85E-04	5.85E-04	5.85E-04	5.85E-04	5.85E-04	1.42E-03
HG	4.00E-01	3.90E-04	9.47E-04	3.0E-04	-	1.30E+00	3.16E+00	1.30E+00	3.16E+00	5.85E-04	5.85E-04	5.85E-04	5.85E-04	5.85E-04	1.42E-03
NI	1.50E+00	1.46E-03	3.55E-03	2.0E-02	-	7.31E-02	1.78E-01	7.31E-02	1.78E-01	5.85E-04	5.85E-04	5.85E-04	5.85E-04	5.85E-04	1.42E-03
PB	4.00E+00	3.90E-03	9.47E-03	1.4E-03	no data	2.79E+00	6.76E+00	2.79E+00	6.76E+00	5.85E-04	5.85E-04	5.85E-04	5.85E-04	5.85E-04	1.42E-03
SB	2.10E+00	2.05E-03	4.97E-03	4.0E-04	-	5.12E+00	1.24E+01	5.12E+00	1.24E+01	5.85E-04	5.85E-04	5.85E-04	5.85E-04	5.85E-04	1.42E-03
SE	4.00E-01	3.90E-04	9.47E-04	5.0E-03	-	7.80E-02	1.89E-01	7.80E-02	1.89E-01	5.85E-04	5.85E-04	5.85E-04	5.85E-04	5.85E-04	1.42E-03
TL	2.10E+00	2.05E-03	4.97E-03	8.0E-05	-	2.56E+01	6.22E+01	2.56E+01	6.22E+01	5.85E-04	5.85E-04	5.85E-04	5.85E-04	5.85E-04	1.42E-03
ZN	6.60E+00	6.43E-03	1.56E-02	3.0E-01	-	2.14E-02	5.21E-02	2.14E-02	5.21E-02	5.85E-04	5.85E-04	5.85E-04	5.85E-04	5.85E-04	1.42E-03

Note: gray shaded cells in Slope Factor column have no known human chemical cancer risk.

Note: gray shaded cells in Carcinogenic Risk columns have no known human chemical cancer risk.

TABLE D.3.3-43.—Ingestion of Metals in Bottom-Feeding Fish for a Special Pathway Receptor
(Note: Uses Regional Statistical Reference Level (RSRL) Data, LANL 1997, see Table D.3.5-12)-Continued

Average-Case Ingestion	(EPA 1997a, Native American Subsistence)
70 g/day	= number of grams per day ingested
17.92 g/day	= number of grams per day dry weight ingested
Worst-Case Ingestion	(EPA 1997a, Native American Subsistence)
170 g/day	= number of grams per day ingested
43.52 g/day	= number of grams per day dry weight ingested
Dry/Wet Weight Fraction	(Fresquez and Ferenbaugh 1998)
0.256 unitless	= LANL dry/wet weight ratio in fish 1990 to 1995
Unit Conversion Factor	
1.00E-03 mg/μg	= number of milligrams per microgram
Average Man Weight	
71.8 kg	= number of kg for an average man

TABLE D.3.3-44.—Ingestion of Elk for a Special Pathway Receptor
 (Note: Includes Elk from Chama, Lindreth, and Tres Piedras, Fresquez et al. 1994,
 see Table D.3.5-13)

ANALYTE	HEART 95% UCL (pCi/g) dry wt.	LIVER 95% UCL (pCi/g) dry wt.	DOSE CONVERSION FACTOR (rem/pCi)	HEART AVERAGE- CASE DOSE (rem/year)	LIVER AVERAGE- CASE DOSE (rem/year)
Cesium-137	6.79E-02	5.96E-01	5.00E-08	1.48E-06	2.27E-05
Plutonium-238	0.00E+00	7.50E-05	3.80E-06	0.00E+00	2.17E-07
Plutonium-239	6.55E-04	9.50E-05	4.30E-06	1.23E-06	3.11E-07
Strontium-90	6.50E-03	8.20E-03	1.30E-07	3.68E-07	8.12E-07
Uranium	3.47E-02	1.60E-02	2.60E-07	3.93E-06	3.18E-06
				Heart Average-Case	Liver Average-Case
Total Dose (rem/yr)				7.01E-06	2.72E-05
Cancer Risk yr-1				3.51E-09	1.36E-08
Heart Average-Case Consumption	(Fresquez et al. 1994)				
3.98 g/day	= number of grams per day ingested (at 3.2 lbs/yr)				
1.194 g/day	= number of grams per day dry weight ingested				
Liver Average-Case Consumption	(Fresquez et al. 1994)				
6.96 g/day	= number of grams per day ingested (at 5.6 lbs/yr)				
2.088 g/day	= number of grams per day dry weight ingested				
Dry/Wet Weight Fraction	(Fresquez and Ferenbaugh 1998)				
0.3 unitless	=LANL dry/wet weight ratio				
Exposure Duration					
365 days	= 1 yr exposure duration				
Uranium Conversion	Heart U=	4.89E-02	µg/g		
	Liver U=	2.26E-02	µg/g		
pCi U isotope/g = µg total uranium/g X RMA X SA X CF					
RMA = relative mass abundance (g isotope per g total U)					
SA = specific activity (pCi/g)					
CF = conversion factor (1E-06 g/µg)					
	Heart	Liver	RMA	SA	CF
U-238=	1.63E-02	7.52E-03	9.93E-01	3.35E+05	1.00E-06
U-235=	7.60E-04	3.51E-04	7.20E-03	2.16E+06	1.00E-06
U-234=	1.77E-02	8.18E-03	5.80E-05	6.24E+09	1.00E-06
Total U Activity (pCi/g) =	3.47E-02	1.60E-02			

TABLE D.3.3-45.—Ingestion of Herbal Tea (Cota) for Special Pathway Receptors
 (Note: Includes Data from San Ildefonso, LANL 1997, see Table D.3.5-14)

ANALYTE	95% UCL (pCi/L)	DOSE CONVERSION FACTOR (rem/pCi)	AVERAGE- CASE DOSE (rem/year)	WORST- CASE DOSE (rem/year)	
Americium-241	7.30E-02	4.50E-06	7.00E-05	2.43E-04	
Cesium-137	5.30E+01	5.00E-08	5.65E-04	1.96E-03	
Plutonium-238	2.80E-02	3.80E-06	2.27E-05	7.88E-05	
Plutonium-239	2.20E-02	4.30E-06	2.02E-05	7.01E-05	
Strontium-90	1.20E+00	1.30E-07	3.33E-05	1.16E-04	
Tritium	1.60E+02	6.30E-11	2.15E-06	7.47E-06	
Uranium	6.46E-01	2.60E-07	3.58E-05	1.24E-04	
			Average-Case	Worst-Case	
Total Dose (rem/yr)			7.49E-04	2.60E-03	
Cancer Risk yr-1			3.74E-07	1.30E-06	
Average-Case Consumption		(EPA 1997a, pg 3-16, Table 3-18)			
0.58 L/day		= mean number of liters per day ingested			
Worst-Case Ingestion		(EPA 1997a, pg 3-16, Table 3-18)			
2.03 L/day		= 99% number of liters per day ingested			
Exposure Duration					
365 days		= 1 yr exposure duration			
Uranium Conversion		U=	9.10E-01	µg/L	
pCi U isotope/L water = µg total uranium/L water X RMA X SA X CF					
RMA = relative mass abundance (g isotope per g total U)					
SA = specific activity (pCi/g)					
CF = conversion factor (1E-06 g/µg)					
			RMA	SA	CF
U-238=	3.03E-01	pCi/L	9.93E-01	3.35E+05	1.00E-06
U-235=	1.42E-02	pCi/L	7.20E-03	2.16E+06	1.00E-06
U-234=	3.29E-01	pCi/L	5.80E-05	6.24E+09	1.00E-06
Total U Activity =	6.46E-01	pCi/L			

TABLE D.3.3–46.—Ingestion of Radionuclides in Vegetables Grown in Contaminated Soil for Comparison Purposes (No Receptor Identified) (Note: On-Site Los Alamos Canyon Data for Pinto Beans, Sweet Corn, and Zucchini Squash, Fresquez et al. 1997, see Table D.3.5–15)

ANALYTE	WEIGHTED ¹ 95% UCL (pCi/g)	DOSE CONVERSION FACTOR (rem/pCi)	AVERAGE- CASE DOSE (rem/year)	WORST- CASE DOSE (rem/year)	
Americium-241	1.68E-04	4.50E-06	8.50E-05	1.98E-04	
Cesium-137	1.47E+00	5.00E-08	8.26E-03	1.92E-02	
Plutonium-238	1.90E-04	3.80E-06	8.12E-05	1.89E-04	
Plutonium-239	5.21E-05	4.30E-06	2.53E-05	5.88E-05	
Strontium-90	4.52E+00	1.30E-07	6.63E-02	1.54E-01	
Tritium ²	1.10E+00	6.30E-11	7.79E-06	1.81E-05	
Uranium	6.92E-04	2.60E-07	2.03E-05	4.72E-05	
¹ Values represent the 95% UCL of the mean of the individual isotopic means for the three vegetable types, weighted by the appropriate dry weight fractions: Pinto Beans, 0.64; Sweet Corn, 0.26; and Zucchini Squash, 0.049 (Fresquez and Ferenbaugh 1998). ² 95% UCL concentration in % of food that is water, also corrected for the water fractions.					
			Vegetables	Vegetables	
			Average-Case	Worst-Case	
Total Dose (rem/yr)			7.48E-02	1.74E-01	
Cancer Risk yr-1			3.74E-05	8.69E-05	
Average-Case Ingestion (EPA 1997a, Table 9-3; 9-4)					
4.30	g/kg-day	= grams of vegetables ingested per day per kg body wt.			
Worst-Case Ingestion (EPA 1997a, Table 9-3; 9-4)					
10.00	g/kg-day	= grams of vegetables ingested per day per kg body wt.			
Exposure Duration					
365	days	= 1 yr exposure duration			
Vegetable Tritium Conversion			H³=	1.097 pCi/mL	
pCi/g of Tritium = pCi/mL tritium X mL/g of water					
water density = 1 g/mL					
Tritium Activity =			1.097	pCi/g	
Vegetable Uranium Conversion			U=	9.75E-04 µg/g	
pCi U isotope/g vegetable = µg total uranium/g vegetable X RMA X SA X CF					
RMA = relative mass abundance (g isotope per g total U)					
SA = specific activity (pCi/g)					
CF = conversion factor (1E-06 g/µg)					
			RMA	SA	CF
U-238=	3.24E-04	pCi/g	9.93E-01	3.35E+05	1.00E-06
U-235=	1.52E-05	pCi/g	7.20E-03	2.16E+06	1.00E-06
U-234=	3.53E-04	pCi/g	5.80E-05	6.24E+09	1.00E-06
Total U Activity =	6.92E-04	pCi/g			

TABLE D.3.3-47.—Ingestion of Metals in Vegetables Grown in Contaminated Soil (No Identified Receptor)
(Note: On-Site Los Alamos Canyon Data for Pinto Beans, Sweet Corn, and Zucchini Squash, Frequez et al., 1997, see Table D.3.5-15)

ANALYTES	WEIGHTED ¹ 95% UCL (µg/g-dry)	AVERAGE- CASE CHRONIC DAILY INTAKE mg/kg-day	WORST- CASE CHRONIC DAILY INTAKE mg/kg-day	ORAL RfD mg/kg-day	ORAL SLOPE FACTOR per (mg/kg)/day	AVERAGE- CASE HAZARD INDEX	WORST- CASE HAZARD INDEX	AVERAGE- CASE CANCER RISK	WORST- CASE CANCER RISK
AS	8.70E-02	3.74E-04	8.70E-04	3.0E-04	1.5E+00	1.25E+00	2.90E+00	5.61E-04	1.31E-03
CD	1.07E-01	4.60E-04	1.07E-03	5.0E-04	1.8E-03	9.20E-01	2.14E+00	8.28E-07	1.93E-06
CR	1.14E-01	4.90E-04	1.14E-03	1.0E+00	-	4.90E-04	1.14E-03		
HG	4.60E-02	1.98E-04	4.60E-04	3.0E-04	-	6.59E-01	1.53E+00		
PB	1.21E+01	5.20E-02	1.21E-01	1.4E-03	no data	3.72E+01	8.64E+01		
SB	1.37E-01	5.89E-04	1.37E-03	4.0E-04	-	1.47E+00	3.43E+00		
ZN	3.31E+01	1.42E-01	3.31E-01	3.0E-01		4.74E-01	1.10E+00		

¹ Values represent the 95% UCL of the mean of the individual means of metal concentrations for the three vegetable types, weighted by the appropriate dry weight fractions: Pinto Beans, 0.64; Sweet Corn, 0.26; and Zucchini Squash, 0.049 (Frequez and Ferenbaugh 1998).

Note: gray shaded cells in Slope Factor column have no known human chemical cancer risk.

Note: gray shaded cells in Carcinogenic Risk columns have no known human chemical cancer risk.

Average-Case Ingestion

4.3 g/kg-day

= number of grams of vegetables ingested per day per kg body wt.

(EPA 1997a, Table 9-3; 9-4)

Worst-Case Ingestion

10 g/kg-day

= number of grams of vegetables ingested per day per kg body wt.

(EPA 1997a, Table 9-3; 9-4)

Units Conversion

1.00E-03 mg/µg

= number of milligrams per microgram

TABLE D.3.3-48.—*Ingestion of Regional Vegetables for Comparison to Table D.3.3-48 (Note: Regional Data for Pinto Beans, Sweet Corn, and Zucchini Squash, Fresquez et al. 1997, see Table D.3.5-15)*

ANALYTES	95% UCL ($\mu\text{g/g-dry}$)	AVERAGE-CASE		WORST-CASE CHRONIC DAILY INTAKE mg/kg-day	ORAL RfD mg/kg-day	ORAL SLOPE FACTOR per ($\text{mg/kg}/\text{day}$)	AVERAGE- CASE HAZARD INDEX	WORST- CASE HAZARD INDEX	AVERAGE- CASE CANCER RISK	WORST- CASE CANCER RISK
		CHRONIC DAILY INTAKE mg/kg-day	CHRONIC DAILY INTAKE mg/kg-day							
AS	1.00E-01	1.36E-04	3.16E-04	3.0E-04	1.5E+00	4.53E-01	1.05E+00	2.04E-04	4.74E-04	
CD	1.20E-01	1.63E-04	3.79E-04	5.0E-04	1.8E-03	3.26E-01	7.58E-01	2.94E-07	6.83E-07	
CR	8.00E-02	1.09E-04	2.53E-04	1.0E+00	-	1.09E-04	2.53E-04			
HG	5.00E-02	6.79E-05	1.58E-04	3.0E-04	-	2.26E-01	5.27E-01			
PB	7.60E+00	1.03E-02	2.40E-02	1.4E-03	no data	7.38E+00	1.72E+01			
SB	1.50E-01	2.04E-04	4.74E-04	4.0E-04	-	5.10E-01	1.19E+00			
ZN	5.10E+01	6.93E-02	1.61E-01	3.0E-01		2.31E-01	5.37E-01			

Note: gray shaded cells in Slope Factor column have no known human chemical cancer risk.

Note: gray shaded cells in Carcinogenic Risk columns have no known human chemical cancer risk.

Average-Case Ingestion	(EPA 1997a, Table 9-3; 9-4)
4.3 g/kg-day	= number of grams of vegetables ingested per day per kg body wt.
0.316 fraction	= % of grams of vegetables ingested per day as dry-wt. (Fresquez and Ferenbaugh 1998)
Worst-Case Ingestion	(EPA 1997a, Table 9-3; 9-4)
10 g/kg-day	= number of grams of vegetables ingested per day per kg body wt.
0.316 fraction	= % of grams of vegetables ingested per day as dry-wt. (Fresquez and Ferenbaugh 1998)
Units Conversion	
1.00E-03 mg/ μg	= number of milligrams per microgram

TABLE D.3.3-49.—Ingestion of Metals in LANL On-Site Fruit (No Identified Receptor)
(Note: Includes On-Site LANL Data, LANL 1997, see Table D.3.5-11)

ANALYTES	95% UCL (µg/g-dry)	AVERAGE- CASE CHRONIC DAILY INTAKE mg/kg-day	WORST- CASE CHRONIC DAILY INTAKE mg/kg-day	ORAL RfD mg/kg-day	ORAL SLOPE FACTOR per (mg/kg)/day	AVERAGE- CASE HAZARD INDEX	WORST- CASE HAZARD INDEX	AVERAGE- CASE CANCER RISK	WORST- CASE CANCER RISK
AG	1.60E-01	8.16E-05	2.98E-04	5.0E-03	-	1.63E-02	5.95E-02		
AS	4.20E-01	2.14E-04	7.81E-04	3.0E-04	1.5E+00	7.14E-01	2.60E+00	3.21E-04	1.17E-03
BA	3.60E+01	1.84E-02	6.70E-02	7.0E-02	-	2.62E-01	9.57E-01		
BE	6.00E-02	3.06E-05	1.12E-04	5.0E-03	4.3E+00	6.12E-03	2.23E-02	1.32E-04	4.80E-04
CD	1.20E-01	6.12E-05	2.23E-04	5.0E-04	1.8E-03	1.22E-01	4.46E-01	1.10E-07	4.02E-07
CR	4.60E-01	2.35E-04	8.56E-04	1.0E+00	-	2.35E-04	8.56E-04		
HG	1.20E-01	6.12E-05	2.23E-04	3.0E-04	-	2.04E-01	7.44E-01		
NI	4.10E+00	2.09E-03	7.63E-03	2.0E-02	-	1.05E-01	3.81E-01		
PB	3.00E+01	1.53E-02	5.58E-02	1.4E-03	no data	1.09E+01	3.99E+01		
SB	1.50E-01	7.65E-05	2.79E-04	4.0E-04	-	1.91E-01	6.98E-01		
SE	7.80E-01	3.98E-04	1.45E-03	5.0E-03	-	7.96E-02	2.90E-01		
TL	1.50E-01	7.65E-05	2.79E-04	8.0E-05	-	9.56E-01	3.49E+00		

Note: gray shaded cells in Slope Factor column have no known human chemical cancer risk.

Note: gray shaded cells in Carcinogenic Risk columns have no known human chemical cancer risk.

Average-Case Ingestion	(EPA 1997a, Table 9-3; 9-4)
3.4 g/kg-day	= number of grams of fruit ingested per day per kg body wt.
0.15 fraction	= % of grams of fruit ingested per day as dry-wt. (Fresquez and Ferenbaugh 1998)
Worst-Case Ingestion	(EPA 1997a, Table 9-3; 9-4)
12.4 g/kg-day	= number of grams of fruit ingested per day per kg body wt.
0.15 fraction	= % of grams of fruit ingested per day as dry-wt. (Fresquez and Ferenbaugh 1998)
Units Conversion	
1.00E-03 mg/µg	= number of milligrams per microgram

TABLE D.3.3–50.—Ingestion of Pinyon Nuts for a Non-Los Alamos County Resident and a Special Pathway Receptor (Note: Non-Los Alamos County includes Pinyon Nuts from Santa Fe, Nambe, and Abiquiu. Special Pathway includes Pinyon Nuts from LANL TA–15, TA–18, TA–21/53, TA–49, TA–2, and TA–54, 1979, Salazar 1979, see Table D.3.5–16)

ANALYTE	NON-LOS ALAMOS COUNTY 95% UCL (pCi/g) dry wt.	SPECIAL PATHWAY 95% UCL (pCi/g) dry wt.	DOSE CONVERSION FACTOR (rem/pCi)	NON-LOS ALAMOS COUNTY AVERAGE-CASE DOSE (rem/year)	SPECIAL PATHWAY AVERAGE-CASE DOSE (rem/year)
Beryllium-7	1.40E-01	2.80E-02	1.10E-10	1.39E-09	2.77E-10
Cesium-137	2.00E-02	2.40E-02	5.00E-08	9.00E-08	1.08E-07
Plutonium-238	1.70E-02		3.80E-06	5.81E-06	
Plutonium-239	1.30E-02	2.70E-01	4.30E-06	5.03E-06	1.04E-04
Strontium-90	2.30E-01	9.20E-01	1.30E-07	2.69E-06	1.08E-05
Tritium ¹	5.70E+00	2.80E+01	6.30E-11	5.06E-07	2.49E-06
Uranium	5.68E-02	5.54E-01	2.60E-07	1.33E-06	1.30E-05
¹ Tritium is determined for the percent that is water. Special pathway tritium is affected by tritium-contaminated soil.					
				NON-LOS ALAMOS COUNTY	SPECIAL PATH
Total Dose (rem/yr)				1.55E-05	1.31E-04
Cancer Risk yr-1				7.73E-09	6.54E-08
Non-Los Alamos County Average-Case Consumption (Salazar 1979)					
1500	g/yr	= number of grams ingested per year			
Special Pathway Average-Case Consumption (Salazar 1979)					
1500	g/yr	= number of grams ingested per year			
Dry/Wet Weight Fraction (Salazar 1979)					
0.06	unitless	= dry/wet weight ratio (mean of 90% to 98% water content)			
Tritium Conversion		Non-Los Alamos County H³=		5.7	pCi/mL
		Special Pathway H³=		28	pCi/mL
pCi/g of Tritium = pCi/mL tritium X mL/g of water					
water density =	1	g/mL			
	Non-Los Alamos County	Spec. Path.			
Tritium Activity =	5.7	28	pCi/g		

TABLE D.3.3–50.—Ingestion of Pinyon Nuts for a Non-Los Alamos County Resident and a Special Pathway Receptor (Note: Non-Los Alamos County includes Pinyon Nuts from Santa Fe, Nambe, and Abiquiu. Special Pathway includes Pinyon Nuts from LANL TA–15, TA–18, TA–21/53, TA–49, TA–2, and TA–54, 1979, Salazar 1979, see Table D.3.5–16)-Continued

Uranium Conversion	Non-Los Alamos County U=		8.00E-02	µg/g	
	Special Pathway U=		7.80E-01	µg/g	
pCi U isotope/g = µg total uranium/g X RMA X SA X CF					
RMA = relative mass abundance (g isotope per g total U)					
SA = specific activity (pCi/g)					
CF = conversion factor (1E-06 g/µg)					
	Non-LAC	Spec. Path.	RMA	SA	CF
U-238=	2.66E-02	2.59E-01	9.93E-01	3.35E+05	1.00E-06
U-235=	1.24E-03	1.21E-02	7.20E-03	2.16E+06	1.00E-06
U-234=	2.90E-02	2.82E-01	5.80E-05	6.24E+09	1.00E-06
Total U (pCi/g) =	5.68E-02	5.54E-01			

D.3.4 Comparison of Concentrations of Selected Radionuclides and Metals in Regional and LANL Perimeter/On-Site Samples of Environmental Media

Table D.3.4–1 summarizes an analysis of differences between samples taken on site or at the perimeter of LANL versus those taken in the general region of northern New Mexico. (The network of annual sampling stations for surface water, groundwater, and sediment surveillance includes a set of regional [or background] stations and a group of stations near or within the LANL boundary—these data are addressed in section D.3.5 and are provided in appendix C.) The concentrations of plutonium-239 were found to be elevated from that of the region in the media at the perimeter of LANL. Values for fruits grown on site, honey from on-site TAs, and deer (road kills) on site showed elevated plutonium-239 concentrations. These foodstuffs are not consumed, but were collected to determine concentrations in biological media in known contaminated areas of the LANL reservation.

D.3.4.1 Arsenic

For most people, the primary mode of arsenic exposure is from food and water consumption. The average ingestion rate for members of the public is about 25 to 50 micrograms per day in food alone (ATSDR 1989 and EPA 1997b). Typically, exposure from water is less. The estimated maximum exposures (95th percentile) to arsenic from ingestion near LANL are:

- Store-bought vegetables (Table D.3.3–37): approximately 31 micrograms per day
- On-site fruit (not consumed, Table D.3.3–49): approximately 61 micrograms per day

- Fish (special pathways consumption rate, Table D.3.3–43): approximately 68 micrograms per day
- Surface waters (Table D.3.3–8): approximately 0.24 microgram per day
- NPDES discharge (Table D.3.3–12): approximately 0.62 microgram per day
- Groundwater (Los Alamos supply, Table D.3.3–2): approximately 98 micrograms per day
- Groundwater (San Ildefonso supply, Table D.3.3–6): approximately 53 micrograms per day

The primary source of arsenic in food and water sources in the LANL area are naturally occurring in soil and basalt minerals and are almost entirely inorganic in form (LANL 1997). The concentrations of arsenic in groundwater supply wells are not significantly different between Los Alamos and San Ildefonso (appendix C).

The main uses of arsenic in the U.S. are in pesticide formulation. LANL does not utilize arsenic in manufacturing levels in its research and development or processing activities. Arsenic is known to be beneficial or necessary for human metabolism in micro-quantities (ATSDR 1989).

When amounts less than 200 to 250 micrograms per day of arsenic are ingested, the human body can detoxify the inorganic form of arsenic by “methylation” (that is, by the addition of methyl groups to the ionic form). This does provide protection from toxic effects of inorganic arsenic. It does not necessarily protect against carcinogenesis. One hypothesis suggests that the natural methylation are “stolen” from deoxyribonucleic acid (DNA) synthesis making chromosome damage more probable (CLAWS 1997).

The single most characteristic system of ingestion exposure to inorganic arsenic is a pattern of skin abnormalities including the

TABLE D.3.4-1.—Comparison of Concentrations of Selected Radionuclides and Metals in Regional and Perimeter or On-Site Media

MEDIUM	NUCLIDE/ METAL	SIGNIFICANT DIFFERENCES IN PROPORTION OF SAMPLES HAVING ABOVE DETECTION CONCENTRATIONS	SIGNIFICANT DIFFERENCES IN CONCENTRATIONS
Surface Water	Cesium-137	NSD	NSD
	Plutonium-239	Perimeter > Regional	Perimeter > Regional
	Strontium-90	Regional > Perimeter	Perimeter > Regional
	Uranium	Regional > Perimeter	Regional > Perimeter
	Arsenic	Regional > Perimeter	Regional > Perimeter
	Beryllium	NSD	NSD
	Lead	Regional > Perimeter	Regional > Perimeter
Sediment	Cesium-137	NSD	NSD
	Plutonium-239	NSD	Perimeter > Regional
	Strontium-90	NSD	NSD
	Uranium	NSD	NSD
	Arsenic	NSD	NSD
	Beryllium	NSD	NSD
	Lead	NSD	NSD
Groundwater	Cesium-137	NSD	San Ildefonso Wells > LA Supply Wells
	Plutonium-239	NSD	NSD
	Strontium-90	NSD	NSD
	Uranium	NSD	NSD
	Arsenic	San Ildefonso Wells > LA Supply Wells	NSD
	Beryllium	San Ildefonso Wells > LA Supply Wells	San Ildefonso Wells > LA Supply Wells
	Lead	NSD	NSD
Soils	Cesium-137	NA	NSD
	Plutonium-239	NA	NSD
	Strontium-90	NA	NSD
	Uranium	NA	NSD
	Arsenic	NA	NSD
	Beryllium	NA	NSD
	Lead	NA	NSD

TABLE D.3.4-1.—Comparison of Concentrations of Selected Radionuclides and Metals in Regional and Perimeter or On-Site Media-Continued

MEDIUM	NUCLIDE/ METAL	SIGNIFICANT DIFFERENCES IN PROPORTION OF SAMPLES HAVING ABOVE DETECTION CONCENTRATIONS	SIGNIFICANT DIFFERENCES IN CONCENTRATIONS
Fruit	Cesium-137	NA	NSD
	Plutonium-239	NA	Los Alamos ^a > Neighboring Counties > Store Bought
	Strontium-90	NA	NSD
	Uranium	NA	NSD
Elk	Cesium-137	NA	NSD
	Plutonium-239	NA	insufficient data
	Strontium-90	NA	insufficient data
	Uranium	NA	NSD
Deer	Cesium-137	NA	NSD
	Plutonium-239	NA	Los Alamos ^a > neighboring counties
	Strontium-90	NA	insufficient data
	Uranium	NA	NSD
Honey	Tritium	NA	Los Alamos ^a > neighboring counties
Vegetables	Cesium-137	NA	NSD
	Plutonium-239	NA	NSD
	Strontium-90	NA	NSD
	Uranium	NA	NSD
	Arsenic	NA	NSD
	Beryllium	NA	NSD
	Lead	NA	NSD
Milk	Cesium-137	NA	NSD
	Iodine-131	NA	NSD
	Plutonium-239	no detects	insufficient data
	Strontium-90	no detects	insufficient data
	Tritium	no detects	insufficient data
	Uranium	NA	NSD

Source: Tables D.3.3-1 through D.3.3-49, and D.3.5-1 through D.3.5-9.

NSD = No (statistically) significant difference

NA = Not applicable

^a These values are for samples collected in known contaminated areas on site. These foodstuffs are not consumed as home produce and are not allowed to be placed into commerce.

appearance of dark and light spots on the skin and small “corns” on the palms, soles, and trunk. While these skin changes are not considered to be a health concern in their own right, some may progress toward skin cancer. In addition, arsenic ingestion has been reported to increase the risk of certain cancers: liver, bladder, kidney, and lung. Organic forms of arsenic such as that found in fish seem to be less toxic than inorganic forms (ATSDR 1989).

EPA has recently held public meetings regarding its activity to develop proposed National Primary Drinking Water Regulations. The current Interim Water Primary Standard for arsenic is 50 micrograms per liter in drinking water and was established in 1976 to protect against skin cancer. This standard was scheduled for finalization with the other phase II compounds in 1991. However, due to new evidence (from Taiwanese epidemiological studies) implicating arsenic in the development of other and more serious internal cancers, the maximum contaminant level (MCL) for arsenic was delayed.

EPA has discussed in public meetings a new MCL between 0.5 and 2 micrograms per liter based on a multistage, linear modeling study of potential human risk. Based on this model, a 1 in 1,000,000 cancer risk level would be 2 parts per billion (2 parts per billion or 2 microgram per liter). The groundwater supplies used in Los Alamos County and San Ildefonso have a 95th percentile UCL of 40 micrograms per liter and 22 micrograms per liter, respectively, based on the 1991 to 1996 LANL Environmental Surveillance Reports. The concentrations are lower than the current MCL for arsenic of 50 micrograms per liter. These concentrations are in and above the ranges EPA is considering in the new MCL for arsenic. While LANL operations do not affect arsenic risk to the public, the range of arsenic concentrations in the region of LANL are in the range that may be potentially be in the range for carcinogenesis at a rate in excess of 1 in 1,000,000.

D.3.4.2 Beryllium

Beryllium is a hard grayish metal that, in nature, is usually found in mineral compounds, especially in coal and in volcanic rock and weathered volcanic soils. Some beryllium is soluble but most is insoluble. Most soil beryllium-containing minerals have low solubilities (ATSDR 1993).

Ingestion risks from beryllium are very low, but beryllium is a suspected human carcinogen (EPA 1997b). The oral (ingestion) reference dose (RfD) is limited to soluble beryllium salts and is 5×10^{-3} milligrams per kilograms-day. The estimated maximum exposures (95th percentile) from ingestion of total beryllium near LANL range from 10^{-3} to 10^{-5} milligrams per kilograms-day. The concentrations of beryllium in the waters in the LANL area are in the 1 to 10 micrograms per liter range.

The primary risk from beryllium is from inhalation, which can lead to Chronic Beryllium Disease. Beryllium workers at LANL are protected from beryllium in the workplace under the Guidance for Implementation of DOE Order 440.1 section addressing “Chronic Beryllium Disease Prevention Program.” The potential consequences of beryllium emissions from HE testing at LANL is discussed in sections 5.2.6.1 and 5.3.6.1.

D.3.4.3 Lead

Lead is an element found throughout the Earth’s crust. Inorganic lead compounds are much less toxic than organic lead compounds. Exposure is primarily by inhalation and ingestion. Exposure to environmental media containing lead is the primary source of elevated blood levels of lead in children. Lead-containing paint in the home is the principal environmental lead source. At levels less than 20 micrograms per deciliter in the blood of a pregnant woman for even a short term (less than 14 days), low birth rate and

learning impairment in the infant may occur. Longer exposures of young children can result in reduced IQ and slowed growth rates. Brain and kidney damage in children can result from blood levels of lead between 70 and 100 micrograms per deciliter.

Concentrations of lead in soil/sediments and water are in the range of 10 to 100 milligrams per kilogram and 1 to 10 micrograms per liter, respectively. In Los Alamos County supply wells, the concentrations of lead are not

significantly different from the oral reference dose (1.4×10^{-3} milligrams per kilograms-day). Lead in environmental media near LANL is not significantly different from that in the entire region. Concentrations of lead are not expected to be affected by continued LANL operations, even in the Expanded Operations Alternative for HE testing (sections 5.2.6.1 and 5.3.6.1). Although lead is a suspected carcinogen, EPA has not established an oral or inhalation slope factor for risk estimation.

D.3.5 Data Used in the Human Health Analysis

Data used for estimating dose and risk for various pathways and receptors are provided in Tables C-1, C-2, C-4, and C-6 in appendix C as well as the tables included in this section (Tables D.3.5-1 through D.3.5-16). These data were taken from sampling locations that form the network of monitors on and around LANL. These data are routinely reported in the LANL annual environmental surveillance reports (such as LANL 1994).

Not all data sets were collected for the same years. Each data table in this SWEIS specifies the years reported.

Environmental restoration site data are presented in Tables C-8 and C-9 in appendix C. In general, these were not used to estimate risk to MEIs because they are in known contaminated areas that are not subject to public exposure. In cases where use of this data was considered appropriate, the discussion of the methodology and analysis identified the data used.

**TABLE D.3.5-1.—Location of Foodstuffs and Receptors Used for Consequence Analysis
(ESH-20 Foodstuffs Database, 1990 to 1994)**

RECEPTOR	MATRIX	LOCATION
Los Alamos Resident	Elk (Bone)	Chama
	Elk (Bone)	Lindreth
	Elk (Bone)	Tres Piedras
	Elk (Muscle)	Chama
	Elk (Muscle)	Lindreth
	Elk (Muscle)	Tres Piedras
	Fruit	Los Alamos
	Fruit	White Rock
	Honey	Los Alamos
	Honey	White Rock
	Milk	Albuquerque
	Vegetable	Los Alamos
	Vegetable	White Rock
Non-Los Alamos Resident	Elk (Bone)	TA-16/S-Site Road
	Elk (Bone)	TA-18/Pajarito Road
	Elk (Bone)	TA-46/Pajarito Road
	Elk (Bone)	TA-49/State Road 4
	Elk (Bone)	TA-49/Water Canyon
	Elk (Bone)	TA-5/Mortandad Canyon
	Elk (Muscle)	TA-16S-Site Road
	Elk (Muscle)	TA-18/Pajarito Road
	Elk (Muscle)	TA-46/Pajarito Road
	Elk (Muscle)	TA-49/State Road 4
	Elk (Muscle)	TA-49/Water Canyon
	Elk (Muscle)	TA-5/Mortandad Canyon
	Fish (Game)	Cochiti
	Fish (Nongame)	Cochiti
	Fruit	San Ildefonso
	Honey	Pojoaque
	Honey	San Ildefonso
	Milk	Nambe
	Vegetable	San Ildefonso

**TABLE D.3.5-1.—Location of Foodstuffs and Receptors Used for Consequence Analysis
(ESH-20 Foodstuffs Database, 1990 to 1994)-Continued**

RECEPTOR	MATRIX	LOCATION
On-Site, No Receptor	Fruit	LANL
	Honey	TA-15
	Honey	TA-16
	Honey	TA-21
	Honey	TA-33
	Honey	TA-35
	Honey	TA-49
	Honey	TA-5
	Honey	TA-53
	Honey	TA-54
	Honey	TA-8
	Honey	TA-9
	Vegetable	LANL
Regional	Fish (Game)	Abiquiu
	Fish (Nongame)	Abiquiu
	Fruit	Cochiti/Peña Blanca/Santo Domingo
	Fruit	Española/Santa Fe/Jemez
	Honey	San Pedro
	Vegetable	Cochiti/Peña Blanca/Santo Domingo
	Vegetable	Española/Santa Fe/Jemez

**TABLE D.3.5-2.—Los Alamos Water Supply Detection Statistics Used in Consequence Analysis
(Environmental Surveillance Database, 1991 to 1996)**

ANALYTE ^a	UNITS ^b	DETECTED	ANALYZED	MINIMUM	MEAN	MAXIMUM	95% UCL ^c
Americium-241	pCi/l	29	37	0.002	0.04	0.109	0.093
Cesium-137	pCi/l	28	50	0.08	59.0	431	280.0
Gross Alpha	pCi/l	33	52	0.2	1.3	3	2.7
Gross Beta	pCi/l	52	52	1	3.6	9	7.0
Gross Gamma	pCi/l	32	48	10	140.0	552	410.0
Tritium	nCi/l	30	54	0.003	0.39	1.1	0.84
Plutonium-238	pCi/l	33	60	0.00010	0.01	0.026	0.024
Plutonium-239, Plutonium-240	pCi/l	44	60	0.00010	0.038	0.669	0.24
Strontium-90	pCi/l	10	25	0.2	1.3	4.6	4.5
Uranium	µg/l	34	55	0.15	0.89	2.2	1.8
Silver	µg/l	10	55	2	37.0	58	82.0
Aluminum	µg/l	6	56	30	140.0	280	300.0
Arsenic	µg/l	33	56	2	12.0	48	40.0
Boron	µg/l	37	56	10	44.0	500	200.0
Barium	µg/l	39	45	5	38.0	88	84.0
Beryllium	µg/l	5	56	1	1.4	2	2.5
Cadmium	µg/l	2	56	1.8	3.4	5	7.9
Cobalt	µg/l	2	54	3	67.0	130	250.0
Chromium	µg/l	31	56	2	8.1	30	19.0
Copper	µg/l	27	56	1	12.0	51	33.0
Iron	µg/l	12	56	10	200.0	830	680.0
Mercury	µg/l	6	45	0.1	0.17	0.2	0.27
Manganese	µg/l	11	56	1	8.8	69	49.0
Molybdenum	µg/l	19	56	1	4.7	30	18.0
Nickel	µg/l	3	56	10	16.0	20	27.0

**TABLE D.3.5-2.—Los Alamos Water Supply Detection Statistics Used in Consequence Analysis
(Environmental Surveillance Database, 1991 to 1996)-Continued**

ANALYTE ^a	UNITS ^b	DETECTED	ANALYZED	MINIMUM	MEAN	MAXIMUM	95% UCL ^c
Lead	µg/l	17	59	1	15.0	95	64.0
Antimony	µg/l	12	56	0.7	1.5	4	3.4
Selenium	µg/l	4	56	1.7	2.2	2.7	3.0
Tin	µg/l	5	44	10	19.0	34	39.0
Strontium	µg/l	52	56	38	87.0	170	150.0
Thallium	µg/l	4	56	0.3	9.8	19	26.0
Vanadium	µg/l	48	56	7	32.0	260	110.0
Zinc	µg/l	26	56	5	23.0	54	49.0
Calcium	mg/l	56	56	5	15.0	32	28.0
Chlorine	mg/l	52	53	2	3.9	8	7.0
Cyanide	mg/l	1	46	0.01	0.01	0.01	
Carbonate	mg/l	1	56	2	2.0	2	
Fluorine	mg/l	56	56	0.2	0.9	28	8.3
Hardness	mg/l	56	56	5	51.0	119	100.0
Bicarbonate	mg/l	56	56	47	84.0	152	130.0
Potassium	mg/l	48	56	1	2.6	4.4	4.0
Lithium	mg/l	9	9	0.024	0.033	0.043	0.046
Magnesium	mg/l	50	56	0.2	3.4	9.4	8.4
Sodium	mg/l	56	56	10	20.0	45	37.0
Nitrate as Nitrogen	mg/l	58	60	0.1	0.81	9.9	3.5
Phosphate as Phosphorous	mg/l	23	56	0.02	0.15	0.3	0.37
Silica	mg/l	55	56	24	73.0	98	110.0
Sulfate	mg/l	52	53	2	4.2	6.34	6.4
Total Dissolved Solids	mg/l	54	60	90	180.0	320	270.0
Total Suspended Solids	mg/l	4	24	1	1.5	2	2.5

^a Analytes and number of analyses from Guaje and Pajarito Mesa well fields only. No analyses from the LA well field or the Otowi well field are included here.

^b pCi/l is picocuries per liter, nCi/l is nanocuries per liter, µg/l is micrograms per liter, and mg/l is milligrams per liter.

^c Upper confidence limit (UCL) not calculated for number of detected analyses less than two.

TABLE D.3.5-3.—Well LA-5 Detection Statistics Used in Consequence Analysis
(Environmental Surveillance Database, 1991 to 1996)

ANALYTE ^a	UNITS ^b	DETECTED	MINIMUM	MEAN	MAXIMUM	95% UCL ^c
Americium-241	pCi/l	2	0.028	0.03	0.031	0.034
Cesium-137	pCi/l	2	1.7	38.0	74.0	140.0
Gross Alpha	pCi/l	2	0.92	0.96	1.0	1.1
Gross Beta	pCi/l	4	2.0	2.7	4.0	4.7
Gross Gamma	pCi/l	3	50.0	120.0	190.0	270.0
Tritium	nCi/l	2	0.1	0.15	0.2	0.29
Plutonium-238	pCi/l	2	0.0086	0.023	0.038	0.065
Plutonium-239, Plutonium-240	pCi/l	3	0.01	0.022	0.034	0.047
Strontium-90	pCi/l	3	0.1	0.27	0.6	0.84
Uranium	µg/l	3	1.0	1.1	1.2	1.3
Chloroethane	µg/l	1	13.0	13.0	13.0	
Aluminum	µg/l	1	62.0	62.0	62.0	
Arsenic	µg/l	3	2.0	2.7	3.0	3.8
Boron	µg/l	2	8.0	14.0	20.0	31.0
Barium	µg/l	3	58.0	61.0	65.0	68.0
Chromium	µg/l	3	4.8	13.0	26.0	36.0
Iron	µg/l	3	160.0	330.0	630.0	850.0
Mercury	µg/l	1	0.1	0.1	0.1	
Manganese	µg/l	3	8.0	18.0	36.0	49.0
Molybdenum	µg/l	1	1.7	1.7	1.7	
Antimony	µg/l	1	0.3	0.3	0.3	
Selenium	µg/l	1	2.0	2.0	2.0	
Tin	µg/l	1	10.0	10.0	10.0	
Strontium	µg/l	4	160.0	200.0	230.0	260.0
Thallium	µg/l	1	0.04	0.04	0.04	

**TABLE D.3.5-3.—Well LA-5 Detection Statistics Used in Consequence Analysis
(Environmental Surveillance Database, 1991 to 1996)-Continued**

ANALYTE ^a	UNITS ^b	DETECTED	MINIMUM	MEAN	MAXIMUM	95% UCL ^c
Vanadium	µg/l	4	10.0	19.0	31.0	37.0
Zinc	µg/l	4	3.9	380.0	1,300	1,600
Calcium	mg/l	4	18.0	20.0	21.0	23.0
Chlorine	mg/l	4	3.0	3.9	5.5	6.2
Fluorine	mg/l	4	0.5	13.0	49.0	61.0
Hardness	mg/l	4	46.0	52.0	56.0	61.0
Bicarbonate	mg/l	4	68.0	75.0	88.0	93.0
Potassium	mg/l	3	2.0	2.0	2.0	2.0
Magnesium	mg/l	3	0.8	0.84	0.9	0.95
Sodium	mg/l	4	14.0	20.0	34.0	39.0
Nitrate as Nitrogen	mg/l	4	0.2	0.45	0.76	0.92
Phosphate as Phosphorous	mg/l	1	0.1	0.1	0.1	
Silica	mg/l	4	40.0	42.0	43.0	44.0
Sulfate	mg/l	4	4.0	5.6	6.5	7.8
Total Dissolved Solids	mg/l	4	140.0	160.0	180.0	200.0

^a Analytes and number of detected analyses from LA-5 only.

^b pCi/l is picocuries per liter, nCi/l is nanocuries per liter, µg/l is micrograms per liter, and mg/l is milligrams per liter.

^c Upper confidence limit (UCL) not calculated for number of detected analyses less than two.

TABLE D.3.5-4.—NPDES Analyte Summary Statistics Used in Consequence Analysis (ESH NPDES Data, 1994 to 1996)

ANALYTE ^a	UNITS ^b	DETECTED	ANALYZED	MINIMUM	MEAN	MAXIMUM	95% UCL
Aluminum (T)	mg/l	40	117	0.06	0.24	1.2	0.75
Arsenic (T)	mg/l	60	99	0.0016	0.0062	0.072	0.026
Boron (T)	mg/l	118	118	0.01	0.082	2.5	0.54
Cadmium (T)	mg/l	27	117	0.0001	0.0015	0.023	0.01
Chromium (T)	mg/l	79	115	0.004	0.012	0.07	0.038
Cobalt (T)	mg/l	23	118	0.0005	0.0062	0.028	0.017
Copper (T)	mg/l	69	115	0.004	0.044	0.59	0.25
Lead (T)	mg/l	24	117	0.0002	0.0084	0.045	0.032
Mercury (T)	mg/l	6	117	0.0003	0.00063	0.0017	0.0017
Radium-226, Radium-228	pCi/l	117	117	0.02	1.7	18.503	7.3
Selenium (T)	mg/l	18	118	0.001	0.0021	0.0063	0.0046
Tritium	pCi/l	65	118	6	2,900	134143	37,000
Vanadium (T)	mg/l	111	117	0.003	0.018	0.12	0.047
Zinc (T)	mg/l	106	117	0.016	0.082	1.2	0.34

^a (T) signifies that the total amount of the analyte in the sample was measured (both the dissolved amount and the amount adsorbed to suspended particles).

^b mg/l is milligrams per liter; pCi/l is picocuries per liter.

**TABLE D.3.5-5.—Soil Detection Statistics Used in Consequence Analysis
(Environmental Surveillance Soils Data, 1992 to 1996)**

LOCATION ^a	ANALYTE	UNITS ^b	DETECTED ^c	ANALYZED ^d	MINIMUM ^e	MEAN ^f	MAXIMUM	95% UCL
On-Site (used for both Resident, Recreational User, and Nonresident Recreational User)	Tritium	pCi/ml				0.67		2.3
	Cesium-137	pCi/g				0.45		1.0
	Plutonium-238	pCi/g				0.008		0.02
	Plutonium-239, Plutonium-240	pCi/g				0.077		0.4
	Strontium-90	pCi/g				0.42		0.78
	Uranium	µg/g				3.0		4.8
	Americium-241	pCi/g				0.009		0.019
	Gross Alpha	pCi/g				6.5		14.0
	Gross Beta	pCi/g				6.6		19.0
	Gross Gamma	pCi/g				3.5		4.1
	Silver	µg/g	11			0.9		2.3
	Aluminum	µg/g	10			3.4		4.3
	Arsenic	µg/g	11			2.6		3.7
	Boron	µg/g	10			16.0		24.0
	Barium	µg/g	11			120.0		170.0
	Beryllium	µg/g	11			0.74		1.0
	Cadmium	µg/g	11			0.2		0.27
	Chromium	µg/g	11			8.3		12.0
	Cobalt	µg/g	10			5.2		7.9
	Copper	µg/g	10			6.0		9.7
	Iron	µg/g	10			1.3		1.8
	Mercury	µg/g	11			0.03		0.04
	Manganese	µg/g	10			350.0		610.0
	Molybdenum	µg/g	10			0.66		0.93
	Nickel	µg/g	11			6.3		9.7
	Lead	µg/g	11			17.0		30.0
	Antimony	µg/g	10			0.17		0.45

**TABLE D.3.5-5.—Soil Detection Statistics Used in Consequence Analysis
(Environmental Surveillance Soils Data, 1992 to 1996)-Continued**

LOCATION ^a	ANALYTE	UNITS ^b	DETECTED ^c	ANALYZED ^d	MINIMUM ^e	MEAN ^f	MAXIMUM	95% UCL
On-Site (used for both Resident, Recreational User, and Nonresident Recreational User) (cont.)	Selenium	µg/g	11			0.31		0.48
	Tin	µg/g	10			8.7		12.0
	Strontium	µg/g	10			27.0		39.0
	Thallium	µg/g	10			0.52		0.93
	Vanadium	µg/g	10			21.0		30.0
	Zinc	µg/g	10			34.0		49.0
	Tritium	pCi/ml				0.24		0.76
	Cesium-137	pCi/g				0.38		0.98
	Plutonium-238	pCi/g				0.007		0.029
	Plutonium-239, Plutonium-240	pCi/g				0.051		0.21
	Strontium-90	pCi/g				0.34		0.7
	Uranium	µg/g				3.0		4.4
	Americium-241	pCi/g				0.011		0.037
Perimeter (used for both Los Alamos County Resident and Non-Los Alamos County Resident)	Gross Alpha	pCi/g				4.6		8.6
	Gross Beta	pCi/g				5.2		8.2
	Gross Gamma	pCi/g				3.7		4.5
	Silver	µg/g	10			0.66		1.4
	Aluminum	µg/g	7			3.3		3.5
	Arsenic	µg/g	10			2.4		3.9
	Boron	µg/g	7			8.0		14.0
	Barium	µg/g	10			96.0		160.0
	Beryllium	µg/g	10			0.66		0.99
	Cadmium	µg/g	10			0.27		0.6
	Chromium	µg/g	10			8.0		13.0
	Cobalt	µg/g	7			4.7		8.2
	Copper	µg/g	7			5.9		9.0
	Iron	µg/g	7			1.2		1.6

**TABLE D.3.5-5.—Soil Detection Statistics Used in Consequence Analysis
(Environmental Surveillance Soils Data, 1992 to 1996)-Continued**

LOCATION ^a	ANALYTE	UNITS ^b	DETECTED ^c	ANALYZED ^d	MINIMUM ^e	MEAN ^f	MAXIMUM	95% UCL	
Perimeter (used for both Los Alamos County Resident and Non-Los Alamos County Resident) (cont.)	Mercury	µg/g	10			0.03		0.05	
	Manganese	µg/g	7			380.0		650.0	
	Molybdenum	µg/g	7			0.68		0.85	
	Nickel	µg/g	10			5.5		8.6	
	Lead	µg/g	10			19.0		36.0	
	Antimony	µg/g	7			0.14		0.17	
	Selenium	µg/g	10			0.34		0.64	
	Tin	µg/g	7			7.7		10.0	
	Strontium	µg/g	7			23.0		36.0	
	Thallium	µg/g	7			0.68		1.7	
	Vanadium	µg/g	7			15.0		29.0	
	Zinc	µg/g	7			33.0		49.0	
	Regional	Tritium	pCi/ml				-0.1		0.36
		Cesium-137	pCi/g				0.28		0.54
		Plutonium-238	pCi/g				0.004		0.008
		Plutonium-239, Plutonium-240	pCi/g				0.011		0.019
Strontium-90		pCi/g				0.3		0.44	
Uranium		µg/g				1.9		2.7	
Americium-241		pCi/g				0.006		0.008	
Gross Alpha		pCi/g				4.8		7.2	
Gross Beta		pCi/g				4.5		5.9	
Gross Gamma		pCi/g				2.8		3.6	
Silver		µg/g	6			1.1		2.1	
Aluminum		µg/g	6			2.9		3.7	
Arsenic	µg/g	6			3.1		6.1		
Boron	µg/g	6			12.0		17.0		
Barium	µg/g	6			130.0		190.0		

**TABLE D.3.5-5.—Soil Detection Statistics Used in Consequence Analysis
(Environmental Surveillance Soils Data, 1992 to 1996)-Continued**

LOCATION ^a	ANALYTE	UNITS ^b	DETECTED ^c	ANALYZED ^d	MINIMUM ^e	MEAN ^f	MAXIMUM	95% UCL
Regional (cont.)	Beryllium	µg/g	6			0.49		0.74
	Cadmium	µg/g	6			0.2		0.2
	Chromium	µg/g	6			10.0		15.0
	Cobalt	µg/g	6			4.8		6.7
	Copper	µg/g	6			7.8		11.0
	Iron	µg/g	6			1.5		2.2
	Mercury	µg/g	6			0.02		0.02
	Manganese	µg/g	6			280.0		420.0
	Molybdenum	µg/g	6			0.63		0.79
	Nickel	µg/g	6			8.0		11.0
	Lead	µg/g	6			11.0		14.0
	Antimony	µg/g	6			0.14		0.2
	Selenium	µg/g	6			0.38		0.62
	Tin	µg/g	6			11.0		16.0
	Strontium	µg/g	6			89.0		260.0
	Thallium	µg/g	6			0.3		0.84
	Vanadium	µg/g	6			26.0		40.0
	Zinc	µg/g	6			34.0		49.0

^a On-site, perimeter and regional designations in accordance with Environmental Surveillance Program.

^b pCi/g is picocuries per gram, pCi/ml is picocuries per milliliter, µg/g is micrograms per gram.

^c Number of detected analyses not available. Values represent the number of means (from Fresquez et al. 1997).

^d Number of analyses not available.

^e Minimum and maximum values not available.

^f Values are means for radiochemical constituents and mean of means for trace metal constituents.

**TABLE D.3.5-6.—Foodstuffs Used in Consequence Analysis Sorted by Receptor
(ESH-20 Foodstuffs Database, 1990 to 1994)**

RECEPTOR	MATRIX	ANALYTE	UNITS ^a	DETECTED	ANALYZED	MINIMUM	MEAN	MAXIMUM	95% UCL ^b
Los Alamos County Resident	Elk (Muscle)	Cesium-137	pCi/g dry	5	5	0.0118	0.21	0.504	0.63
	Elk (Muscle)	Uranium	µg/g dry	3	5	0.0005	0.0016	0.0022	0.0035
	Fruit	Cesium-137	pCi/g dry	19	31	0.0076	0.12	0.6427	0.49
	Fruit	Tritium	nCi/l	27	31	0.2	2.1	16	9.1
	Fruit	Plutonium-238	pCi/g dry	15	31	0.00056	0.00032	0.001231	0.00097
	Fruit	Plutonium-239	pCi/g dry	22	31	0.00003	0.0013	0.020374	0.0099
	Fruit	Strontium-90	pCi/g dry	25	25	0.0069	0.042	0.1647	0.12
	Fruit	Uranium	µg/g dry	30	30	0.0006	0.012	0.08278	0.045
	Honey	Tritium	nCi/l	4	4	0.2	10.0	37.3	46.0
	Milk	Cesium-137	pCi/l	1	1	2.41	2.4	2.41	
	Milk	Iodine-131	pCi/l	1	1	10	10.0	10	
	Milk	Uranium	µg/l	1	1	0.1	0.1	0.1	
	Vegetable	Cesium-137	pCi/g dry	27	45	0.0031	0.13	0.7328	0.44
	Vegetable	Tritium	nCi/l	41	45	0.1	0.52	1.3	1.1
	Vegetable	Plutonium-238	pCi/g dry	29	45	0.000015	0.00021	0.00098	0.00065
	Vegetable	Plutonium-239	pCi/g dry	33	45	0.000023	0.00083	0.0196	0.0076
	Vegetable	Strontium-90	pCi/g dry	36	36	0.0053	0.064	0.855	0.34
Vegetable	Uranium	µg/g dry	43	45	0.00026	0.0042	0.02085	0.011	
Non-Los Alamos County Resident	Elk (Muscle)	Cesium-137	pCi/g dry	6	8	0.0113	0.12	0.2504	0.3
	Elk (Muscle)	Tritium	nCi/l	3	3	0.1	1.8	4.7	6.9
	Elk (Muscle)	Plutonium-238	pCi/g dry	1	8	0.00002	0.00002	0.00002	
	Elk (Muscle)	Plutonium-239	pCi/g dry	4	8	0.00002	0.000086	0.000252	0.00031
	Elk (Muscle)	Strontium-90	pCi/g dry	3	8	0.0042	0.0072	0.0126	0.017
	Elk (Muscle)	Uranium	µg/g dry	4	7	0.0001	0.0028	0.0086	0.011
	Fish (Game)	Cesium-137	pCi/g dry	4	5	0.006	0.093	0.203	0.28
	Fish (Game)	Plutonium-238	pCi/g dry	5	5	0.00003	0.000049	0.00008	0.000088
	Fish (Game)	Plutonium-239	pCi/g dry	4	5	0.00004	0.000062	0.00009	0.00011
	Fish (Game)	Strontium-90	pCi/g dry	5	5	0.041	0.072	0.092	0.11

**TABLE D.3.5-6.—Foodstuffs Used in Consequence Analysis Sorted by Receptor
(ESH-20 Foodstuffs Database, 1990 to 1994)-Continued**

RECEPTOR	MATRIX	ANALYTE	UNITS ^a	DETECTED	ANALYZED	MINIMUM	MEAN	MAXIMUM	95% UCL ^b
Non-Los Alamos County Resident (cont.)	Fish (Game)	Uranium	µg/g dry	5	5	0.0048	0.0054	0.00664	0.0069
	Fish (Nongame)	Cesium-137	pCi/g dry	5	5	0.001	0.059	0.178	0.22
	Fish (Nongame)	Plutonium-238	pCi/g dry	4	5	0.00003	0.000047	0.000076	0.000087
	Fish (Nongame)	Plutonium-239	pCi/g dry	3	5	0.00002	0.000044	0.00006	0.000087
	Fish (Nongame)	Strontium-90	pCi/g dry	5	5	0.015	0.026	0.049	0.057
	Fish (Nongame)	Uranium	µg/g dry	5	5	0.0059	0.011	0.02042	0.022
	Fruit	Cesium-137	pCi/g dry	8	12	0.007	0.058	0.1588	0.18
	Fruit	Tritium	nCi/l	5	11	0.1	0.28	0.7	0.76
	Fruit	Plutonium-238	pCi/g dry	6	11	0.000058	0.000098	0.000205	0.00021
	Fruit	Plutonium-239	pCi/g dry	8	12	0.000019	0.00034	0.002132	0.0018
	Fruit	Strontium-90	pCi/g dry	9	11	0.0026	0.023	0.0896	0.084
	Fruit	Uranium	µg/g dry	12	12	0.0007	0.003	0.00788	0.0078
	Honey	Tritium	nCi/l	6	9	0.1	0.38	0.7	0.79
	Milk	Cesium-137	pCi/l	1	1	3.1	3.1	3.1	3.1
	Milk	Tritium	nCi/l	1	1	0.1	0.1	0.1	0.1
	Milk	Iodine-131	pCi/l	1	1	4.7	4.7	4.7	4.7
	Milk	Plutonium-238	pCi/l	1	1	0.003	0.003	0.003	0.003
	Milk	Uranium	µg/l	1	1	0.24	0.24	0.24	0.24
	Vegetable	Cesium-137	pCi/g dry	11	13	0.0119	0.46	2.484	2.0
	Vegetable	Tritium	nCi/l	9	13	0.1	0.53	1	1.1
	Vegetable	Plutonium-238	pCi/g dry	6	13	0.000025	0.001	0.0024	0.0028
	Vegetable	Plutonium-239	pCi/g dry	10	13	0.000036	0.00025	0.000959	0.00079
	Vegetable	Strontium-90	pCi/g dry	11	11	0.0252	0.12	0.2898	0.28
Vegetable	Uranium	µg/g dry	13	13	0.00066	0.046	0.27489	0.2	
Fruit	Cesium-137	pCi/g dry	11	27	0.0004	0.061	0.2427	0.21	
Fruit	Tritium	nCi/l	25	27	0.1	2.2	8.9	7.0	
Fruit	Plutonium-238	pCi/g dry	14	26	0.000025	0.00017	0.000778	0.00055	
Fruit	Plutonium-239	pCi/g dry	17	27	0.00005	0.00018	0.000488	0.00043	
Fruit	Strontium-90	pCi/g dry	20	21	0.005	0.044	0.1344	0.12	
On-Site, No Receptor									

**TABLE D.3.5-6.—Foodstuffs Used in Consequence Analysis Sorted by Receptor
(ESH-20 Foodstuffs Database, 1990 to 1994)-Continued**

RECEPTOR	MATRIX	ANALYTE	UNITS ^a	DETECTED	ANALYZED	MINIMUM	MEAN	MAXIMUM	95% UCL ^b
On-Site, No Receptor (cont.)	Fruit	Uranium	µg/g dry	27	27	0.00027	0.011	0.0394	0.034
	Honey	Tritium	nCi/l	49	54	0.1	62.0	1300	460.0
	Vegetable	Cesium-137	pCi/g dry	4	10	0.0014	0.0042	0.0092	0.011
	Vegetable	Tritium	nCi/l	10	10	0.1	0.78	2.7	2.6
	Vegetable	Plutonium-238	pCi/g dry	5	10	0.000047	0.00023	0.000363	0.00055
	Vegetable	Plutonium-239	pCi/g dry	8	10	0.000044	0.00029	0.000678	0.00079
	Vegetable	Strontium-90	pCi/g dry	9	10	0.0154	0.038	0.059	0.065
	Vegetable	Uranium	µg/g dry	10	10	0.00132	0.0036	0.00655	0.0074
	Fish (Game)	Cesium-137	pCi/g dry	5	5	0.001	0.046	0.108	0.15
	Fish (Game)	Plutonium-238	pCi/g dry	3	5	0.00002	0.000032	0.000045	0.000057
	Fish (Game)	Plutonium-239	pCi/g dry	4	5	0.00003	0.000068	0.00014	0.00017
	Fish (Game)	Strontium-90	pCi/g dry	5	5	0.01	0.043	0.116	0.13
	Fish (Game)	Uranium	µg/g dry	5	5	0.00091	0.0021	0.0033	0.0043
	Fish (Nongame)	Cesium-137	pCi/g dry	5	5	0.008	0.11	0.268	0.31
Fish (Nongame)	Plutonium-238	pCi/g dry	5	5	0.00001	0.000041	0.000076	0.00009	
Fish (Nongame)	Plutonium-239	pCi/g dry	4	5	0.000029	0.000067	0.00018	0.00022	
Fish (Nongame)	Strontium-90	pCi/g dry	5	5	0.026	0.038	0.047	0.056	
Fish (Nongame)	Uranium	µg/g dry	5	5	0.0043	0.0057	0.00748	0.0082	
Fruit	Cesium-137	pCi/g dry	22	45	0.0005	0.075	0.374	0.27	
Fruit	Tritium	nCi/l	27	44	0.1	0.41	1	0.93	
Fruit	Plutonium-238	pCi/g dry	21	45	0.000023	0.00016	0.0005	0.00041	
Fruit	Plutonium-239	pCi/g dry	32	45	0.000023	0.00017	0.00117	0.00065	
Fruit	Strontium-90	pCi/g dry	32	34	0.0019	0.026	0.0798	0.073	
Fruit	Uranium	µg/g dry	45	45	0.00052	0.011	0.08295	0.041	
Honey	Tritium	nCi/l	2	5	0.2	0.25	0.3	0.39	
Vegetable	Cesium-137	pCi/g dry	44	59	0.0004	0.12	0.4133	0.35	
Vegetable	Tritium	nCi/l	44	58	0.1	0.35	0.9	0.79	
Vegetable	Plutonium-238	pCi/g dry	21	58	0.00001	0.00016	0.000492	0.00042	
Vegetable	Plutonium-239	pCi/g dry	32	59	0.00001	0.00025	0.002394	0.0012	

TABLE D.3.5-6.—Foodstuffs Used in Consequence Analysis Sorted by Receptor (ESH-20 Foodstuffs Database, 1990 to 1994)-Continued

RECEPTOR	MATRIX	ANALYTE	UNITS ^a	DETECTED	ANALYZED	MINIMUM	MEAN	MAXIMUM	95% UCL ^b
Regional (cont.)	Vegetable	Strontium-90	pCi/g dry	43	45	0.003	0.038	0.1592	0.11
	Vegetable	Uranium	µg/g dry	58	59	0.0003	0.0089	0.03991	0.027

^a pCi/g dry is picocuries per gram dry weight, µg/g is micrograms per gram dry weight, nCi/l is nanocuries per liter, and µg/l is micrograms per liter.

^b Upper confidence limit (UCL) not calculated for number of detected analyses less than two.

TABLE D.3.5-7.—Free-Range Steer Muscle Radiochemical Summary Statistics Used in Consequence Analysis (ESH-20 Data for 1996)

LOCATION	ANALYTE	UNITS ^a	DETECTED ^b	ANALYZED ^c	MINIMUM ^d	MEAN ^e	MAXIMUM	95% UCL
Perimeter	Tritium	nCi/l				-0.4		0.2
San Ildefonso (used for Non-Los Alamos County Resident)	Strontium-90	pCi/g dry				0.011		0.026
	Plutonium-238	pCi/g dry				0.0		0.00003
	Plutonium-239	pCi/g dry				0.000074		0.00015
	Cesium-137	pCi/g dry				0.014		0.021
	Americium-241	pCi/g dry				0.000037		0.000067
	Uranium	µg/g dry				0.0015		0.0018

^a nCi/l is nanocuries per liter, pCi/g dry is picocuries per gram dry weight, µg/g is micrograms per gram dry weight.

^b Number of detected analyses not available.

^c Number of analyses not available.

^d Minimum and maximum values not available.

^e Means and standard deviation values (not given here) are from 1996 surveillance data. The calculation of mean values includes negative and zero values.

TABLE D.3.5-8.—Deer Muscle Radiochemical Summary Statistics Used in Consequence Analysis (ESH-20 Data for 1996)

LOCATION	ANALYTE	UNITS ^a	DETECTED ^b	ANALYZED ^c	MINIMUM ^d	MEAN ^e	MAXIMUM	95% UCL
On-Site (Non-Los Alamos County Resident)	Tritium	nCi/l				0.36		0.99
	Strontium-90	pCi/g dry				-0.0023		0.023
	Plutonium-238	pCi/g dry				0.000012		0.00005
	Plutonium-239	pCi/g dry				0.000016		0.000056
	Cesium-137	pCi/g dry				0.11		0.5
	Americium-241	pCi/g dry				0.000023		0.000079
	Uranium	µg/g dry				0.7		0.7
Regional (Los Alamos County Resident)	Tritium	nCi/l				0.15		0.86
	Strontium-90	pCi/g dry				0.01		0.038
	Plutonium-238	pCi/g dry				-0.000025		0.000046
	Plutonium-239	pCi/g dry				0.00005		0.00019
	Cesium-137	pCi/g dry				0.018		0.027
	Americium-241	pCi/g dry				0.0		0.0
	Uranium	µg/g dry				0.00075		0.0015

^a nCi/l is nanocuries per liter, pCi/g dry is picocuries per gram dry weight, µg/g is micrograms per gram dry weight.

^b Number of detected analyses not available.

^c Number of analyses not available.

^d Minimum and maximum values not available.

^e Means and standard deviation values (not given here) are from 1996 surveillance data. The calculation of mean values includes negative and zero values.

TABLE D.3.5-9.—Analysis of Fish Used in Consequence Analysis (ESH-20 Foodstuffs Database, 1990 to 1994)

ANALYTE	UNITS ^a	DETECTED	ANALYZED	MINIMUM	MEAN	MAXIMUM	95% UCL
Cesium-137	pCi/g dry	19	20	0.001	0.075	0.268	.024
Plutonium-238	pCi/g dry	17	20	0.00001	0.000043	0.00008	0.000082
Plutonium-239	pCi/g dry	15	20	0.00002	0.000061	0.00018	0.00015
Strontium-90	pCi/g dry	20	20	0.01	0.045	0.116	0.1
Uranium	µg/g dry	20	20	0.00091	0.0061	0.02042	0.015

^a pCi/g dry is picocuries per gram dry weight, and µg/g dry is micrograms per gram dry weight.

TABLE D.3.5-10.—Bottom-Feeding Fish Chemical Summary Statistics Used in Consequence Analysis (ESH-20 Data, 1996)

RECEPTOR ^a	ANALYTE	UNITS ^b	DETECTED ^c	ANALYZED ^d	MINIMUM ^e	MEAN ^f	MAXIMUM	95% UCL
Non-Los Alamos County Resident	Silver	µg/g wet				0.13		0.13
	Arsenic	µg/g wet				0.25		0.25
	Barium	µg/g wet				0.063		0.063
	Beryllium	µg/g wet				0.053		0.053
	Cadmium	µg/g wet				0.11		0.11
	Chromium	µg/g wet				0.63		0.63
	Copper	µg/g wet				0.82		0.82
	Mercury	µg/g wet				0.34		0.34
	Nickel	µg/g wet				1.1		1.1
	Lead	µg/g wet				1.3		1.3
	Antimony	µg/g wet				1.3		1.3
	Selenium	µg/g wet				0.28		0.28
	Thallium	µg/g wet				1.3		1.3
Zinc	µg/g wet				5.8		9.1	

^a Data from Abiquiu, Heron, and El Vado.

^b µg/g wet is micrograms per gram wet.

^c Number of detected analyses not available.

^d Number of analyses not available.

^e Minimum and maximum values not available.

^f Means and standard deviation values (not given here) are from 1996 surveillance data. The calculation of mean values includes negative and zero values.

TABLE D.3.5-11.—Produce Chemical Summary Statistics Used in Consequence Analysis (ESH-20 Data, 1996)

RECEPTOR	MATRIX	ANALYTE	UNITS ^a	DETECTED ^b	ANALYZED ^c	MINIMUM ^d	MEAN ^e	MAXIMUM	95% UCL	
Los Alamos County Resident	Fruit	Silver	µg/g dry		2	0.27	0.43	0.58	0.86	
		Arsenic	µg/g dry		2	0.1	0.1	0.1	0.1	
		Barium	µg/g dry		2	1.91	2.1	2.27	2.6	
		Beryllium	µg/g dry		2	0.06	0.06	0.06	0.06	
		Cadmium	µg/g dry		2	0.12	0.12	0.12	0.12	
		Chromium	µg/g dry		2	0.5	1.0	1.51	2.4	
		Mercury	µg/g dry		2	0.05	0.05	0.05	0.05	
		Nickel	µg/g dry		2	2.76	3.9	5.09	7.2	
		Lead	µg/g dry		2	2.8	3.1	3.3	3.8	
		Antimony	µg/g dry		2	0.15	0.15	0.15	0.15	
		Selenium	µg/g dry		2	0.1	0.1	0.1	0.1	
		Thallium	µg/g dry		2	0.15	0.15	0.15	0.15	
		Vegetable	Silver	µg/g dry		12	0.27	0.32	0.56	0.54
			Arsenic	µg/g dry		12	0.1	0.1	0.1	0.1
			Barium	µg/g dry		12	0.26	10.0	27.7	25.0
			Beryllium	µg/g dry		12	0.06	0.06	0.06	0.06
			Cadmium	µg/g dry		12	0.12	0.12	0.12	0.12
			Chromium	µg/g dry		12	0.13	0.7	3.09	2.5
Mercury	µg/g dry			12	0.05	0.05	0.05	0.05		
Nickel	µg/g dry			12	1.36	5.6	17	17.0		
Lead	µg/g dry			12	0.6	8.7	48	39.0		
Antimony	µg/g dry			12	0.15	0.19	0.4	0.39		
Selenium	µg/g dry		12	0.1	0.22	0.4	0.44			
Thallium	µg/g dry		12	0.15	0.15	0.15	0.15			

TABLE D.3.5-11.—Produce Chemical Summary Statistics Used in Consequence Analysis (ESH-20 Data, 1996)-Continued

RECEPTOR	MATRIX	ANALYTE	UNITS ^a	DETECTED ^b	ANALYZED ^c	MINIMUM ^d	MEAN ^e	MAXIMUM	95% UCL		
Non-Los Alamos County Resident	Vegetable	Silver	µg/g dry		5	0.16	0.16	0.16	0.16		
		Arsenic	µg/g dry		5	0.15	0.2	0.4	0.42		
		Barium	µg/g dry		5	0.82	13.0	29.9	36.0		
		Beryllium	µg/g dry		5	0.06	0.06	0.06	0.06		
		Cadmium	µg/g dry		5	0.12	0.12	0.12	0.12		
		Chromium	µg/g dry		5	0.08	0.17	0.4	0.46		
		Mercury	µg/g dry		5	0.05	0.06	0.1	0.1		
		Nickel	µg/g dry		5	0.36	1.2	3.6	4.1		
		Lead	µg/g dry		5	1	6.8	27.1	30.0		
		Antimony	µg/g dry		5	0.15	0.15	0.15	0.15		
		Selenium	µg/g dry		5	0.1	0.34	0.7	0.78		
		Thallium	µg/g dry		5	0.15	0.15	0.15	0.15		
		On-Site, No Receptor	Fruit	Silver	µg/g dry		6	0.16	0.16	0.16	0.16
				Arsenic	µg/g dry		6	0.1	0.17	0.5	0.49
Barium	µg/g dry				6	2.49	6.7	16.7	17.0		
Beryllium	µg/g dry				6	0.06	0.06	0.06	0.06		
Cadmium	µg/g dry				6	0.12	0.12	0.12	0.12		
Chromium	µg/g dry				6	0.08	0.1	0.22	0.22		
Mercury	µg/g dry				6	0.05	0.067	0.1	0.12		
Nickel	µg/g dry				6	0.36	0.86	1.43	1.7		
Lead	µg/g dry				6	2.9	7.0	12.6	15.0		
Antimony	µg/g dry				6	0.15	0.15	0.15	0.15		
Selenium	µg/g dry		6	0.1	0.15	0.3	0.32				
Thallium	µg/g dry		6	0.15	0.15	0.15	0.15				

TABLE D.3.5-11.—Produce Chemical Summary Statistics Used in Consequence Analysis (ESH-20 Data, 1996)-Continued

RECEPTOR	MATRIX	ANALYTE	UNITS ^a	DETECTED ^b	ANALYZED ^c	MINIMUM ^d	MEAN ^e	MAXIMUM	95% UCL
Regional	Vegetable	Silver	µg/g dry		13	0.16	0.24	0.58	0.47
		Arsenic	µg/g dry		13	0.1	0.18	1.1	0.73
		Barium	µg/g dry		13	0.35	6.0	18.4	17.0
		Beryllium	µg/g dry		13	0.06	0.06	0.06	0.06
		Cadmium	µg/g dry		13	0.12	0.14	0.32	0.25
		Chromium	µg/g dry		13	0.13	1.0	4.35	4.0
		Mercury	µg/g dry		13	0.05	0.054	0.1	0.082
		Nickel	µg/g dry		13	0.36	6.5	28.6	25.0
		Lead	µg/g dry		13	1.1	8.4	26.4	28.0
		Antimony	µg/g dry		13	0.15	0.15	0.15	0.15
		Selenium	µg/g dry		13	0.1	0.22	0.4	0.44
		Thallium	µg/g dry		13	0.15	0.15	0.15	0.15

^a µg/g dry is micrograms per gram dry weight.

^b Number of detected analyses not available. The dataset included substituted values in place of nondetects, and then all analyses were used in calculating the summary statistics.

^c Data are 1996 surveillance data.

TABLE D.3.5-12.—Bottom-Feeding Fish Regional Statistic Reference Levels Used in Consequence Analysis (ESH-20 Data, 1996)

RECEPTOR	ANALYTE	UNITS ^a	DETECTED ^b	ANALYZED ^c	MINIMUM ^d	MEAN	MAXIMUM	95% UCL ^e
Special Pathway	Silver	µg/g wet						1.2
	Arsenic	µg/g wet						0.4
	Barium	µg/g wet						1.2
	Beryllium	µg/g wet						1.3
	Cadmium	µg/g wet						0.3
	Chromium	µg/g wet						1.5
	Copper	µg/g wet						1.4
	Mercury	µg/g wet						0.4
	Nickel	µg/g wet						1.5
	Lead	µg/g wet						4.0
	Antimony	µg/g wet						2.1
	Selenium	µg/g wet						0.4
	Thallium	µg/g wet						2.1
	Zinc	µg/g wet						6.6

^a µg/g wet is micrograms per gram wet.

^b Number of detected analyses not available.

^c Number of analyses not available.

^d Minimum, maximum, and mean values not available.

^e Upper confidence limit, given as the regional statistical reference level, was obtained from 1996 surveillance data. The calculations includes negative and zero values.

TABLE D.3.5-13.—Elk Tissue Radiochemical Summary Statistics Used in Consequence Analysis (ESH-20 Data for 1991 to 1993)

LOCATION	TISSUE	ANALYTE	UNITS ^a	DETECTED ^b	ANALYZED ^c	MINIMUM ^d	MEAN ^e	MAXIMUM	95% UCL	
On-Site (No Receptor)	Heart	Cesium-137	pCi/g dry				0.041		0.12	
		Plutonium-238	pCi/g dry				0.00005		0.00017	
	Liver	Plutonium-239	pCi/g dry				0.000023		0.000065	
		Strontium-90	pCi/g dry				0.002		0.009	
		Uranium	µg/g dry				0.0007		0.0041	
		Cesium-137	pCi/g dry				0.17		0.49	
		Plutonium-238	pCi/g dry				0.000013		0.000059	
		Plutonium-239	pCi/g dry				0.000033		0.000095	
	Regional (Special Pathways)	Heart	Strontium-90	pCi/g dry				0.004		0.012
			Uranium	µg/g dry				0.0046		0.017
Liver		Cesium-137	pCi/g dry				0.058		0.068	
		Plutonium-238	pCi/g dry				0.0		0.0	
		Plutonium-239	pCi/g dry				0.00015		0.00066	
		Strontium-90	pCi/g dry				0.0023		0.0065	
		Uranium	µg/g dry				0.011		0.049	
		Cesium-137	pCi/g dry				0.22		0.6	
		Plutonium-238	pCi/g dry				0.000017		0.000075	
		Plutonium-239	pCi/g dry				0.000033		0.000095	
Strontium-90	pCi/g dry				0.003		0.0082			
Uranium	µg/g dry				0.0052		0.023			

^a pCi/g dry is picocuries per gram dry weight, µg/g is micrograms per gram dry weight.

^b Number of detected analyses not available.

^c Number of analyses not available.

^d Minimum and maximum values not available.

^e Means and standard deviation values (not given here) are from Frequez et al. 1994. The calculation of mean values may include negative and zero values in their calculation.

TABLE D.3.5-14.—Navajo Tea (Cota) Radiochemical Summary Statistics Used in Consequence Analysis (ESH-20 Data, 1996)

LOCATION	ANALYTE	UNITS ^a	DETECTED ^b	ANALYZED ^c	MINIMUM ^d	MEAN ^e	MAXIMUM	95% UCL
Perimeter San Ildefonso (Special Pathway)	Tritium	nCi/l				-0.11		0.16
	Strontium-90	pCi/l				0.4		1.2
	Plutonium-238	pCi/l				0.018		0.028
	Plutonium-239	pCi/l				0.011		0.022
	Cesium-137	pCi/l				18.0		53.0
	Americium-241	pCi/l				0.015		0.073
	Uranium	µg/l				0.75		0.91

^a nCi/l is nanocuries per liter, pCi/l is picocuries per liter, µg/l is micrograms per liter.

^b Number of detected analyses not available.

^c Number of analyses not available.

^d Minimum and maximum values not available.

^e Means and standard deviation values (not given here) are from 1996 surveillance data. The calculation of mean values includes negative and zero values.

TABLE D.3.5-15.—Edible Portions of Beans, Corn, and Squash Used in Consequence Analysis (ESH-20 Data, 1996)

LOCATION	FOODSTUFF	ANALYTE	UNITS ^a	DETECTED ^b	ANALYZED ^c	MINIMUM ^d	MEAN ^e	MAXIMUM	95% UCL
On-Site (Special Pathway)	Vegetables	Tritium	nCi/l				0.9		1.3
		Cesium-137	pCi/g dry				3.0		5.5
		Strontium-90	pCi/g dry				11.0		14.0
		Plutonium-238	pCi/g dry				0.00056		0.00022
		Plutonium-239	pCi/g dry				0.00032		0.0006
		Americium-241	pCi/g dry				0.00077		0.0013
		Uranium	µg/g dry				0.002		0.0044
		Arsenic	µg/g dry				0.14		0.34
		Cadmium	µg/g dry				0.15		0.22
		Chromium	µg/g dry				0.16		0.5
		Mercury	µg/g dry				0.05		0.05
		Lead	µg/g dry				7.5		9.4
		Antimony	µg/g dry				0.15		0.15
		Zinc	µg/g dry				47.0		71.0
Regional	Vegetables	Tritium	nCi/l				0.03		0.66
		Cesium-137	pCi/g dry				0.021		0.069
		Strontium-90	pCi/g dry				0.038		0.06
		Plutonium-238	pCi/g dry				0.000019		0.000097
		Plutonium-239	pCi/g dry				0.000054		0.00013
		Americium-241	pCi/g dry				0.00013		0.00025
		Uranium	µg/g dry				0.0034		0.0042
		Arsenic	µg/g dry				0.1		0.1
		Cadmium	µg/g dry				0.12		0.12
		Chromium	µg/g dry				0.08		0.08
		Mercury	µg/g dry				0.05		0.05
		Lead	µg/g dry				4.6		7.6
		Antimony	µg/g dry				0.15		0.15
		Zinc	µg/g dry				31.0		51.0

TABLE D.3.5-15.—Edible Portions of Beans, Corn, and Squash Used in Consequence Analysis (ESH-20 Data, 1996)-Continued

- ^a nCi/l is nanocuries per liter, pCi/g dry is picocuries per gram dry weight, µg/g is micrograms per gram dry weight.
- ^b Number of detected analyses not available.
- ^c Number of analyses not available.
- ^d Minimum and maximum values not available.
- ^e Means and standard deviation values (not given here) are from Frequez et al. 1997. The calculation of mean values includes negative and zero values.

TABLE D.3.5-16.—Analysis of Pinyon Nuts Used in Consequence Analysis (Salazar 1979)

RECEPTOR ^a	ANALYTE	UNITS ^b	DETECTED	ANALYZED	MINIMUM	MEAN	MAXIMUM	95% UCL ^c
Special Pathways	Beryllium-7	pCi/g dry	6	6	0.005	0.013	0.024	0.028
	Cesium-137	pCi/g dry	6	6	0.003	0.0092	0.019	0.024
	Tritium	nCi/l	5	5	5.6	13.0	24.2	28.0
	Plutonium-239	pCi/g dry	4	6	0.007	0.068	0.22	0.27
	Strontium-90	pCi/g dry	6	6	0.01	0.33	0.84	0.92
	Uranium	µg/g dry	6	6	0.05	0.21	0.79	0.78
Non-Los Alamos County Resident	Beryllium-7	pCi/g dry	NA	NA	NA	0.023	NA	0.14
	Cesium 137	pCi/g dry	NA	NA	NA	0.004	NA	0.02
	Tritium	nCi/l	NA	NA	NA	4.9	NA	5.7
	Plutonium-238	pCi/g dry	NA	NA	NA	0.007	NA	0.017
	Plutonium-239	pCi/g dry	NA	NA	NA	0.003	NA	0.013
	Strontium-90	pCi/g dry	NA	NA	NA	0.17	NA	0.23
	Uranium	µg/g dry	NA	NA	NA	0.08	NA	0.08

^a Special pathway receptor data is from on-site locations (TA-15, TA-18, TA-21/53, TA-49, TA-52, and TA-54). Non-Los Alamos County Resident data is from regional locations (Nambe, Santa Fe, and Abiquiu).

^b pCi/g dry is picocuries per gram dry weight, nCi/l is nanocuries per liter, and µg/g dry is micrograms per gram dry weight.

^c Upper Confidence Limits (UCL) calculated as the mean plus two standard deviations.

NA = Not available

REFERENCES

- ACGIH 1997 "Beryllium and Compounds," 1997 Supplement, Documentation of the Threshold Limit Values and Biological Exposure Indices. 6th Edition. American Conference of Governmental Industrial Hygienists. Cincinnati, Ohio. 1997.
- Athas 1996 *Investigation of Excess Thyroid Cancer Incidence in Los Alamos*. W. F. Athas. New Mexico Department of Health. April 1996.
- Athas and Key 1993 *Cancer Incidence in Los Alamos County, 1970-1990, Final Report—Los Alamos Cancer Rate Study: Phase I*. W. F. Athas and C. R. Key. New Mexico Department of Health. Santa Fe, New Mexico. March 1993.
- ATSDR 1989 *Arsenic*. U.S. Department of Health and Human Services, Public Health Service, Agency for Toxic Substances and Disease Registering. Available on-line at: <http://www.enznetinc.net/users/themissinglink/Arsenic.htm>.
- ATSDR 1993 *Toxic Substances: Beryllium*. U.S. Department of Health and Human Services, Public Health Service, Agency for Toxic Substances and Disease Registering. Available on-line at: <http://www.enznetinc.net/users/themissinglink/beryllium.htm>.
- BEIR V 1990 *Health Effects of Exposures to Low Levels of Ionizing Radiation*. National Research Council, Committee on the Biological Effects of Ionizing Radiation. National Academy Press. Washington, D.C. 1990.
- Bork 1987 *Natural Resources Defense Council vs. U.S. Environmental Protection Agency*. Opinion, Bork, Circuit Judge. 263 U.S. Appeals, D.C. 166. Decided July 28, 1987.
- Calder 1984 *Size, Function, and Life History*. William Calder. Harvard College. Boston Massachusetts. 1984.
- Cember 1996 *Introduction to Health Physics*, 3d ed. Herman Cember. McGraw-Hill. New York, New York. 1996.
- CLAWS 1997 *Arsenic*. City of Los Angeles Water Services. Available on-line at: <http://www.dwp.ci.la.ca.us/water/quality/wq-arsnc.htm>.
- DOC 1990 *1990 Census of Population: Social and Economic Characteristics, New Mexico*. U.S. Department of Commerce, Bureau of the Census. Washington, D.C. 1990.

- EPA 1989 *Exposure Factors Handbook*. U.S. Environmental Protection Agency. Washington, D.C. 1989.
- EPA 1990 *Protection of Environment*. 40 CFR 300.430. U.S. Environmental Protection Agency. July 1, 1990.
- EPA 1992 *User's Guide for CAP-88 PC*. U.S. Environmental Protection Agency, Air and Radiation Office. 402-B-92-001. Washington, D.C. 1992.
- EPA 1997a *Exposure Factors Handbook*. U.S. Environmental Protection Agency. Washington, D.C. 1997.
- EPA 1997b *Integrated Risk Information System (IRIS) Data Base*. U.S. Environmental Protection Agency, Office of Research and Development. Washington, D.C. 1997.
- ESR Data See individual entries for LANL Environmental Surveillance Reports: LANL 1992 (1990 ESR), LANL 1993 (1991 ESR), LANL 1994 (1992 ESR), LANL 1995 (1993 ESR), LANL 1996a (1994 ESR), LANL 1996b (1995 ESR), LANL 1997 (1996 ESR).
- Foodstuffs Database Data on Food Consumption, obtained from LANL ESH-20 database.
- Fresquez et al. 1994 *Radionuclide Concentrations in Elk that Winter on Los Alamos National Laboratory Lands*. P. R. Fresquez, D. R. Armstrong, and J. G. Salazar. Los Alamos National Laboratory. LA-12795-MS. Los Alamos, New Mexico. 1995.
- Fresquez et al. 1996 *Radionuclides and Radioactivity in Soils Within and Around Los Alamos National Laboratory, 1974 through 1994: Concentrations, Trends, and Dose Comparisons*. P. R. Fresquez, M. A. Mullen, J. K. Ferenbaugh, and R. A. Perona. Los Alamos National Laboratory. LA-13149-MS. Los Alamos, New Mexico. April 1996.
- Fresquez et al. 1997 *Radionuclide Concentrations in Pinto Beans, Sweet Corn, and Zucchini Squash Grown in Los Alamos Canyon at Los Alamos National Laboratory*. P. R. Fresquez, D. R. Armstrong, M. A. Mullen, and L. Narranjo, Jr. Los Alamos National Laboratory. LA-13304-MS. Los Alamos, New Mexico.
- Fresquez and Ferenbaugh 1998 *Moisture Conversion Ratios for the Foodstuffs and Biota Environmental Surveillance Programs at Los Alamos National Laboratory*. P. R. Fresquez and J. K. Ferenbaugh. Los Alamos National Laboratory. LA-UR-98-1054. Los Alamos, New Mexico. March 1998.

- ICRP 1991 “1990 Recommendations of the International Commission on Radiological Protection.” Publication 60, Volume 21, No. 1-3. *Annals of the ICRP*. Pergamon Press. New York, New York. 1991.
- LANL 1992 *Environmental Surveillance at Los Alamos During 1990*. Los Alamos National Laboratory. LA-12271-M8, UC-1990. Los Alamos, New Mexico. March 1992.
- LANL 1993 *Environmental Surveillance at Los Alamos During 1991*. Los Alamos National Laboratory. LA-12572-ENV, UC-902. Los Alamos, New Mexico. August 1993.
- LANL 1994 *Environmental Surveillance at Los Alamos During 1992*. Los Alamos National Laboratory. LA-12764-MS, UC-902. Los Alamos, New Mexico. July 1994.
- LANL 1995 *Environmental Surveillance at Los Alamos During 1993*. Los Alamos National Laboratory. LA-12973-ENV, UC-902. Los Alamos, New Mexico. October 1995.
- LANL 1996a *Environmental Surveillance at Los Alamos during 1994*. Los Alamos National Laboratory, Environmental Assessments and Resource Evaluations Group. LA-13047-ENV. Los Alamos, New Mexico. July 1996.
- LANL 1996b *Environmental Surveillance at Los Alamos During 1995*. Los Alamos National Laboratory. LA-13210-ENV, UC-902. Los Alamos, New Mexico. October 1996.
- LANL 1997 *Environmental Surveillance and Compliance at Los Alamos During 1996*. Los Alamos National Laboratory. LA-13343-ENV. Los Alamos, New Mexico.
- Miller et al. 1996 *Racial/Ethnic Patterns of Cancer in the United States 1988–1992*. B. A. Miller, L. N. Kolonel, L. Bernstein, J. L. Young, Jr., G. M. Swanson, D. West, C. R. Key, J. M. Liff, C. S. Glover, G. A. Alexander, et al. (eds). National Cancer Institute. NIH Pub. No. 96-4104. Bethesda, Maryland. 1996.
- NBS 1952 *Radiological Monitoring Methods and Instruments*. National Bureau of Standards Handbook #51. April 1952.
- NCRP 1981 *Radiofrequency Electromagnetic Fields—Properties, Quantities and Units, Biophysical Interaction, and Measurements*. National Council on Radiation Protection. NCRP Report No. 67. Bethesda, Maryland. 1981.
- NCRP 1986 *Biological Effects and Exposure Criteria for Radiofrequency Electromagnetic Fields*. National Council on Radiation Protection and Measurements. NCRP Report No. 86. Bethesda, Maryland. 1986.

- NCRP 1987 *Exposure of the Population in the United States and Canada from Natural Background Radiation*. Recommendations of the National Council on Radiation Protection and Measurements. NCRP Report No. 94. Bethesda, Maryland. December 1987.
- NCRP 1989 *Comparative Carcinogenicity of Ionizing Radiation and Chemicals*. National Council on Radiation Protection and Measurements. NCRP Report No. 96. March 1, 1989.
- NCRP 1993 *A Practical Guide to the Determination of Human Exposure to Radiofrequency Fields*. National Council on Radiation Protection. NCRP Report No. 119. Bethesda, Maryland. December 31, 1993.
- NPDES Data Data on Water Quality, obtained from the LANL Water Quality and Hydrology Group (ESH-18) NPDES Chemical Database. Only 1994–1996 data available currently.
- OSHA 1997 “Quantitative Risk Assessment.” Occupational Safety and Health Administration. *Federal Register*, Vol. 62, No. 7, pp. 1516–1563. January 10, 1997.
- Ries et al. 1996 *SEER Cancer Statistics Review, 1973-1993*, tables and graphs. L. A. G. Ries, C. L. Kosary, B. F. Hankey, A. HARRAS, B. A. Miller, and B. K. Edwards (eds.). National Institute of Health/National Cancer Institute. Bethesda, Maryland. 1996.
- Robinson and Thomas 1991 *Time Spent in Activities, Locations and Microenvironments: A California-National Comparison Project Report*. J. P. Robinson and J. Thomas. U.S. Environmental Protection Agency, Environmental Monitoring Systems Laboratory. Las Vegas, Nevada. 1991.
- Salazar 1979 *Radionuclide Content of Pinyon Nuts in the Vicinity of the Los Alamos Scientific Laboratory*. J. G. Salazar. Los Alamos Scientific Laboratory. LA-UR-79-238. Los Alamos, New Mexico. 1979.

APPENDIX E

CULTURAL RESOURCES

E.1 OVERVIEW

This appendix provides supplemental information regarding the prehistoric and historic cultural resources present at LANL, including traditional cultural properties (TCP), that may be affected by ongoing and proposed LANL operations. Cultural resources are any prehistoric or historic sites, buildings, structures, districts, or other places or objects (including biota of importance) considered to be important to a culture, subculture, or community for scientific, traditional, or religious purposes, or for any other reason. While not all cultural resources need to be preserved, those with cultural significance require identification and protection so that future generations may be informed and enriched by the past.

In section E.2, information is presented regarding the results of previous cultural resource research in the LANL region. Section E.3 provides a summary of the background of the LANL region that led to a classification system developed for LANL, based on the regional cultural context of prehistoric and historic development on the Pajarito Plateau and the traditional cultures of the region. Section E.4 contains an overview of the major federal and state regulatory requirements concerning cultural resources. Section E.5 contains information regarding the research methods employed to identify, document, and assess the cultural resources likely to be affected by LANL operations. Detailed information is provided in section E.6 on the existing cultural resources that are protected by the *National Historic Preservation Act* (NHPA) (16 U.S.C. §470). Section E.7 is a list of references used in conducting this assessment and preparing this report.

Cultural resources are location-specific; therefore, the cultural resource study area is defined as the area within LANL's physical boundaries and those areas surrounding LANL that may be potentially affected by LANL activities. A broader study area has been defined for the identification and assessment of TCPs, because the TCP evaluation includes an assessment of historical use and value placed on cultural resources by existing cultural groups with current or ancestral ties to the LANL region, irrespective of their current locations.

E.2 PREVIOUS STUDY OF CULTURAL RESOURCES IN THE LANL REGION

The following subsections contain a history and summaries of previous studies of cultural resources in the LANL region.

E.2.1 Studies of Prehistoric Resources

The Pajarito Plateau is among the most intensively studied archaeological regions in the U.S. due in part to the density of archaeological sites. Archaeological study began in 1880 when Adolph Bandelier visited the Puye ruins and Rito de los Frijoles, measuring and taking notes on the ruins (Bandelier 1892). A survey of the Pajarito Plateau was made by Edgar Lee Hewett in 1896 and the results were published in 1904 (Hewett 1904). In 1916, Hewett helped establish Bandelier National Monument (BNM) as one of the first facilities in the region to protect outstanding archeological ruins (Steen 1977).

The School of American Archaeology conducted many field schools at BNM. However, no major reports resulted from these

excavations (Mathien et al. 1993 and Powers and Orcutt 1988). In 1935, the National Park Service (NPS) (which controlled the land on the Pajarito Plateau outside the BNM) produced a map of 200 sites on the Ramon Vigil Grant. Other material from the survey has been lost (Mathien et al. 1993).

Archaeological investigations on the Pajarito Plateau continued after World War II at BNM (Powers 1988, Caywood 1966, and Powers and Orcutt 1988), on the Los Alamos Scientific Laboratory (LASL) (Steen 1982, Worman 1967, and Worman and Steen 1978), and on privatized land in what is now the city of Los Alamos and the community of White Rock (Maxon 1969, Hill and Trierweiler 1986, and Kohler 1989). LASL hired archaeologist F.V. Worman in 1950, and since then, regular archaeological surveys and excavations have been made prior to all construction at LASL/LANL (Mathien et al. 1993, LANL 1986–1995, Steen 1982).

LASL and LANL archaeologists have conducted hundreds of site excavations and surveys and have compiled and published numerous documents over the past 47 years. Although approximately 75 percent of LANL has been archaeologically surveyed (LANL 1995c), the number of cultural resources at LANL, the complexity of their cultural affiliations and types, and the manner in which they have been studied and recorded make systematic classification difficult. A cultural resources bibliography has been compiled for the Pajarito Plateau (Mathien et al. 1993). In addition, the resource records have been included in a relational database and many resurveys and refinements have been made to the original field data (PC 1996).

E.2.2 Studies of Historic Resources at LANL

Increased interest in the documentation and preservation of Nuclear Energy Period

resources has come about since the end of the Cold War and publishing of the National Register of Historic Places (NRHP) guidance on the eligibility of resources less than 50 years old (U.S. Department of Defense [DOD] 1993 and NPS 1990). Citizens of Los Alamos County have supported historic preservation efforts that have focused on the legacy of the Manhattan Project. Survey work conducted in December of 1966 and 1968 resulted in the nomination for listing on the NRHP of the Los Alamos Historic District, including Ashley Pond, Fuller Lodge, Central Avenue LANL Administration Building, Los Alamos County Historical Museum and Archives, and other Manhattan Project properties outside the boundaries of LANL (NMHPD 1995).

While the potential significance of LANL as a site of outstanding importance in the development of nuclear energy is recognized by DOE, the State Historic Preservation Office(r) (SHPO), and the LANL Cultural Resources Management Team, comprehensive surveys have yet to be conducted for Nuclear Energy Period resources at LANL. A survey of 28 Cold War Period resources was conducted in 1995 by the LANL Cultural Resources Management Team prior to decontamination and decommissioning of buildings on the S-Site (TA-16), a critical area of high-explosive atomic research activity for the Manhattan Project. The results of this survey have been published as an Historic Building Survey Report (McGehee 1995). In the report, all 28 buildings were recommended as eligible for listing in the NRHP because of primary or secondary contributions to events of exceptional international importance. These buildings were also identified as contributing properties to a potential World War II and Cold War historic district at TA-16. According to McGehee, “A formal evaluation of the proposed district will be included in an overall evaluation and management document currently being drafted for all historic properties at LANL” (McGehee 1995).

E.2.3 Studies of Traditional Cultural Properties

Previously conducted TCP studies, identified during the course of this study, are summarized below. One problem encountered in compiling this review was a lack of comprehensive files available to researchers conducting ethnographic research in New Mexico. There is no central facility for ethnographic reports or lists of TCP sites.

In the past 5 years, as laws have changed to include protection of traditional places, several studies of TCPs have been conducted in central and northern New Mexico. In 1992, the Fence Lake Ethnographic Study was completed for the Salt River Project's proposed Fence Lake Mine in western New Mexico (Hart and Ferguson 1993). The Pueblos of Zuni and Acoma, the Hopi Tribe, and the Ramah Band of the Navajo Nation participated in this study. Information was collected through a literature study, meetings, and field work with the consulting tribes to document tribal use of the area as well as concerns revolving around proposed development. Several cultural resources significant to the consulting tribes were documented in or adjacent to the LANL region. These resources include the Zuni Salt Lake, the Zuni Salt Lake Neutral Zone, seven historic American Indian trails, numerous sacred places, ancestral homesites, ancestral graves and collection areas, prehistoric Pueblo ruins, and Cerro Prieto, a black volcanic cone. With the exception of the ancestral graves, most of these sites were recommended as eligible as a TCP for inclusion in the NRHP (Hart and Ferguson 1993).

A rapid ethnographic assessment of the Petroglyph National Monument was conducted in 1991 to 1992 to identify those American Indian tribes and Spanish heritage groups who were interested in participating in a long-term consultation process with the NPS concerning the management of the PNM (Evans et al.

1993). Once the groups were identified, cultural resource concerns were identified through letters and meetings with various tribal and Hispanic groups. Although specific cultural resource information was not made public, the consulting parties set forth several recommendations pertaining to management of the Petroglyph National Monument (Evans et al. 1993).

The Office of Contract Archeology at the University of New Mexico completed an ethnographic study of the Fort Wingate Depot Activity in 1994, as part of the closure process of the facility by the U.S. Army (Perlman 1995). The purpose of the study was to conduct a sample survey and an initial TCP assessment of sites located on the base that are of significance to the Navajo and Zuni people. This study was accomplished through a series of meetings and field work with the Church Rock, Iyanbito, and Bread Springs Chapters of the Navajo Nation and the Zuni Heritage and Historic Preservation Office. Through this TCP study and previous investigations, 24 cultural sites were identified, 15 of which were recommended for nomination to the NRHP as TCPs. Eight burials sites were identified and recommended as eligible for protection under the *Native American Graves Protection and Repatriation Act* (NAGPRA) (25 U.S.C. §3001).

American Indian concerns regarding traditional places in the Paseo del Volcan transportation corridor were documented in a study done in 1993 and 1994 as part of a project sponsored by the Federal Highway Administration and the New Mexico State Highway and Transportation Department (SWCA 1995). The purpose of the project was to identify a corridor that could be used to serve future transportation needs in the Albuquerque area. Nineteen New Mexico Pueblos, the Canoncito Navajo Chapter, the Hopi Tribe, and the Jicarilla and Mescalero Apache Tribes were initially contacted. Of this original group, ten expressed concerns about the project. Through a series of letters, meetings, and field work with these groups, concerns were

identified regarding traditional use of the project area. This was only a preliminary study, and no TCPs were identified by the consulting tribes. It became apparent during the study that unless a specific corridor was selected from the alternatives, the tribal consultants would not identify specific places of concerns (SWCA 1995). The Paseo del Volcan corridor study also identified three Hispanic TCPs in the Bernalillo area, including a historic neighborhood, the location of a religious fiesta that includes Matachines dances, and a pilgrimage route (SWCA 1996a).

Three TCP studies have been completed for the U.S. Bureau of Reclamation (Reclamation). In 1995, an initial TCP study was completed of Heron and El Vado Reservoirs in Rio Arriba County (SWCA 1996b). Initial contact letters were mailed to 11 tribes and 3 parish priests in the Chama area. In response to these letters, meetings were held with two of the tribes and one parish priest. The priest also participated in a field visit to the reservoirs. In response to these letters, meetings, and field visit, four Pueblos, the Jicarilla Apache Tribe, and Hispanic communities were identified as having concerns about the protection of potential cultural resources in the area of the two reservoirs (SWCA 1996a). As funding becomes available, a more intensive TCP study will be done for these two reservoirs.

In early 1996, an initial TCP study was completed at the White Ranch Property in Saguache County, in southern Colorado (SWCA 1996c). Contact was initiated with ten tribes in an effort to determine if these groups had concerns regarding the transfer of the White Ranch parcel from Reclamation to the U.S. Department of the Interior (DOI), U.S. Fish and Wildlife Service (FWS). Through this initial consultation, which included letters and meetings, five tribes indicated that they had concerns regarding cultural resources on the parcel. Two tribes requested field visits to the study area. As a result of this initial study, several recommendations were made, mainly in

the form of further consultation and field visits with consulting tribes. Because this parcel is scheduled to be transferred to the FWS, it is anticipated that additional TCP investigations will be conducted (SWCA 1996c).

From 1992 through 1995, one of the more extensive TCP studies was conducted of the Animas-La Plata Project in southwestern Colorado and northwestern New Mexico (NAU and SWCA 1996). At the conclusion, 26 American Indian tribes had become involved in a complex consultation process involving contacts by letters, telephone calls, meetings, and field work. An extensive literature review also provided valuable information to the study. Through this study, TCPs and sacred places were identified, an assessment of the project impacts on these properties and places was made, and management recommendations were provided. The potential TCPs identified in the project area were a prehistoric/historic trail, puebloan habitation and ceremonial archaeological sites, and a traditional collections area (NAU and SWCA 1996).

In July 1995, an initial TCP study was conducted of the Westland Sector Plan Property in Bernalillo County (SWCA 1996d). The client and the city of Albuquerque Planning Department identified the groups to be contacted. These groups included one Pueblo, heirs and stockholders in the Westland Development Company, and two Hispanic community organizations. Consultation took the form of contact through letters, meetings, and interviews. The results of the literature review indicated the presence of various cultural resources on the West Mesa, with the heaviest incidence of use being within the boundaries of the Petroglyph National Monument. With the exception of one land rights organization, these groups did not have concerns regarding cultural resources located within the sector.

E.3 CULTURAL BACKGROUND OF THE LANL REGION

The following subsections contain a history and summaries of previous studies of the cultural background in the LANL region.

E.3.1 Prehistoric Background of the LANL Region

Previous archaeological investigations in the vicinity of the Pajarito Plateau indicate that the area has a history dating back many thousands of years. Researchers have developed socio-historical schemes to describe the cultural periods of the region (Kidder 1927). In 1954, Fred Wendorf defined five major periods for the northern Rio Grande Valley: Preceramic, Developmental, Coalition, Classic, and Historic (Wendorf 1954). These period classifications, with some modifications, are still in use (Pratt and Scurlock 1993). The Preceramic Period has been divided into Paleo-Indian and Archaic, based upon changes in settlement patterns and subsistence over time as reflected by material culture. The Historic Period includes both American Indian sites, where people abandoned their homelands and changed their ways of life in response to Euro-American and other influences, and sites that reflect the European and American settlement of the Rio Grande Valley. A summary of these periods is presented in Table E.3.1–1. Brief discussions of the highlights of each period follow.

E.3.1.1 *Paleo-Indian Period (10,000 Through 4000 B.C.)*

By the end of the Wisconsin glacial stage, 10,000 years ago, the entire area of the North American continent, including New Mexico, was occupied by people whose subsistence was based on hunting and gathering (Willey 1966). Archaeological sites dating from this period contain bones of mammoths and bison and distinctive lanceolate projectile points, in

association with a variety of stone butchering tools and lithic debitage. Paleo-Indian artifacts made of obsidian from the Jemez Mountains have been found in other parts of the Southwest (Broster 1983). Obsidian deposits were exposed in ancient landslides at higher elevations and around the margins of Valle Grande to the northwest (Powers 1988). Sites of the Paleo-Indian Period may be found in any part of LANL; however, no discoveries of Paleo-Indian remains have been made (Wolfman 1994 and LANL 1995c). Paleo-Indian materials have been reported near Cochiti; however, these were confined to surface finds of projectile points and lithic debitage (Biella 1977, Biella and Chapman 1977–1979). Because any information concerning the Paleo-Indian Period would contribute to the development of the historical context, all sites of this period are likely to be significant.

E.3.1.2 *Archaic Period (4000 B.C. Through A.D. 600)*

American Indians altered their lifestyles in response to a continuing shift of the climate toward present-day conditions at the end of the Pleistocene Period. By this period, the big game of the Pleistocene era had died out and a heavier reliance was placed on hunting and gathering. Although bison hunting continued to be important (Stuart and Gauthier 1981), small game such as deer, raccoon, turkey, and squirrel became an increasingly significant component of the diet (Larson 1991). Group movements became tied to the seasonal availability of plants. This change in subsistence was accompanied by a change in the tool assemblage, with broad-stemmed projectile points, stone knives, fish hooks, jewelry, and grinding stones becoming common. Archaic Period sites include cave and rock shelter sites, burned rock features, scatters of tools and lithic debitage, and isolated hearths. On the Pajarito Plateau, Archaic Period sites are most likely to

TABLE E.3.1–1.—Archaeological Periods of Northern New Mexico

TIME PERIOD	PREHISTORIC PERIOD	CHARACTERISTIC SITE TYPES
10,000 through 4000 B.C.	Paleo-Indian	<ul style="list-style-type: none"> • Bones of mammoth or bison • Stone butchering tools • Flakes and chips of stones from making stone tools • Distinctive lance-shaped projective points
4000 B.C. through A.D. 600	Archaic	<ul style="list-style-type: none"> • Caves and rock shelters • Burned rock features • Scatters of tools and stone flakes and chips • Isolated hearths • End of the Archaic period (approximately A.D. 1 to 700) may have pottery grinding stones, and charred corn
A.D. 600 through 1100	Developmental	<ul style="list-style-type: none"> • Ceramic storage and service vessels • Smaller projectile points reflecting the adoption of the bow and arrow • Grinding tools • Dwellings increased in size and complexity from semisubterranean pithouses to small adobe or crude masonry structures
A.D. 1100 through 1325	Coalition	<ul style="list-style-type: none"> • Early sites are rectangular structures of adobe and masonry with basin-shaped, abobe-lines fire pits, usually in the center of the room or against a wall • Comparatively small; pueblos average 28 rooms • Later coalition sites contain plazas and room blocks of more than 100 rooms
A.D. 1325 through 1600	Classic	<ul style="list-style-type: none"> • Large masonry structures of multiple-room blocks • For the Pajarito Plateau, three site clusters, one of which includes Navawi, Otowi, Tsankawi, and Tsirege • Associated one- to two-room isolated structures

Sources: Cordell 1979, Cordell 1984, LANL 1995c, Stuart and Gauthier 1981, Wendorf 1954, and Wolfman 1994.

be represented by concentrations of lithic debitage.

E.3.1.3 Developmental Period (A.D. 600 Through 1100)

About A.D. 600, the prehistoric occupants shifted their subsistence and settlement patterns toward a more sedentary lifestyle and intensified horticultural practices (Powers 1988), including the cultivation of maize, beans, and squash. In the LANL region, the Developmental Period has been subdivided into early and late phases (Wolfman 1994). These

subdivisions appear to reflect observable trends in increased sedentary behavior and social complexity. Additional attributes of the Developmental Period include the advent of ceramic storage and service vessels, smaller projectile points, the adoption of the bow and arrow, continued use of grinding tools, and increases in size and complexity of houses. During the Early Developmental Period (A.D. 600 through 900), single family units were built in semi-subterranean pit houses. Late Developmental Period sites (A.D. 900 through 1099) were typically small adobe or crude masonry structures. Although they are scarce

on the Pajarito Plateau (Wolfman 1994), sites attributable to the Developmental Period have been identified at LANL.

E.3.1.4 *Coalition Period (A.D. 1100 Through 1325)*

During the Coalition Period, the local populations coalesced into larger societal units. Subsistence was based on maize horticulture. The early sites are rectangular structures of adobe and masonry. Basin-shaped, adobe-lined fire pits are usually in the centers of the rooms, or sometimes against a wall. Circular or D-shaped semi-subterranean kivas are often in front of the room blocks (Larson 1991). Fairly small Pueblos, averaging 28 rooms, were typical of the Coalition Period (Wolfman 1994), although late Coalition Period sites are large masonry structures exhibiting plazas and room blocks of over 100 rooms (LANL 1995c). Over 700 Coalition Period ruins have been found within LANL boundaries.

E.3.1.5 *Classic Period (A.D. 1325 Through 1600)*

During the Classic Period, maize-based horticulture intensified and settlements on the Pajarito Plateau further coalesced into three main population centers. One of these site clusters consists of four sites that temporally overlapped: Navawi, Otowi, Tsankawi, and Tsirege (LANL 1995c). These sites are large masonry structures of multiple room blocks, with associated one- or two-room isolated structures. Otowi and Tsirege appear to be the ancestral sites of the Pueblo of San Ildefonso. Severe droughts in the 1500's led to abandonment of many of the Pueblos and the Pajarito Plateau. The scarcity of water and crop failures probably forced gradual relocations to more reliable water sources in the Rio Grande Valley (Sando 1992). Tree-ring dating (dendrochronology) from the Frijoles Canyon Pueblos indicates that the last roof beams were

cut around 1550 (Robinson et al. 1972). The exodus probably took place over many years. At the time of the Spanish arrival in 1597, most activity had ended on the Pajarito Plateau and four Pueblos were established in the adjoining Rio Grande Valley: the Pueblos of Santa Clara, Jemez, San Ildefonso, and Cochiti.

E.3.2 *Historic Background of the LANL Region*

This subsection presents highlights of historic events that occurred in the LANL region.

E.3.2.1 *Spanish Colonial Period (A.D. 1600 Through 1849)*

The inhabitants of the Rio Grande Pueblos still remember their ancestral homes on the Pajarito Plateau at the time of the Spanish Conquest (Hewett and Dutton 1945). There is archaeological evidence that the abandoned canyons with their Pueblos and caves were visited for ceremonial purposes. Pictographs of horse figures exist in some kiva ruins at BNM and on canyon walls in White Rock Canyon (Kessell 1979). These may indicate that the area was occupied by a small remnant population after the Spanish occupation of the Rio Grande Valley. Game pits on the Pajarito Plateau could also date from the time of the Spanish occupation or later. The use of the area from that time forward seems to have been for occasional hunting and gathering or ceremonial use, including burials (Steen 1977). American Indian sites relating to this early Historic Period are classified as historic sites.

The Coronado expedition entered the region of the Rio Grande Pueblos in 1540. Hernando de Alvarado and his commander, Francisco Coronado, waged intermittent battles with individual Pueblos for food and supplies (Kessell 1979). The Spanish did not meet with much success in New Mexico and retreated to Mexico in April 1542 (Jenkins and Schroeder

1974). The 1598 expedition by Juan de Oñate arrived in Northern New Mexico with strong military backing, livestock, and equipment for full colonization. The Pueblos of the Rio Grande Valley continued to shrink in size during this 50-year interlude, and some locations inhabited when Coronado first entered the Valley were no longer occupied when Oñate arrived (Schroeder 1979). Pueblo leaders voluntarily took oaths of allegiance to the Spanish Crown and accepted the Franciscans who took up residence in each Pueblo. Churches were added to each Pueblo early in the seventeenth century (Simmons 1979a).

In 1610, the Spanish capital of New Mexico was relocated to Santa Fe by Governor Pedro de Peralta (Kessell 1979). The extensive Palace of the Governors was built to serve the administration of New Mexico as the settlement of the area continued (Kessell 1979). This Spanish Colonial Period was not peaceful, and the Pueblos were beset by incursions from the Spanish settlers, epidemics of smallpox and other deadly diseases, and continual attacks by Apaches (Simmons 1979a). In 1680, the Pueblos openly revolted against Spanish rule, attacking the Spanish settlers and Franciscans in the Rio Grande Valley and laying siege to the Palace of the Governors in Santa Fe. The Spanish Governor, Otermin, and most other Spanish settlers were forced south to El Paso (Hendricks 1993). American Indian governors ruled New Mexico from the Palace of the Governors for 12 years, until 1693 when Spanish control was reestablished. In 1821, the Spanish population in New Mexico had reached 20,000 to 25,000 (Simmons 1979b).

In the late seventeenth century, the Spanish Crown provided land grants adjoining the Pajarito Plateau to four Pueblos in New Mexico (Brayer 1938). The Jemez Pueblo was originally granted 17,331 acres (7,014 hectares) in 1689. Pueblo de Cochiti was granted over 20,000 acres (8,094 hectares); Santa Clara Pueblo was granted 44,818 acres (18,138 hectares); and San Ildefonso Pueblo

was granted 15,413 acres (6,237 hectares) during this period (Simmons 1979a). American Indian populations continued to decline from disease during the Spanish occupation. The Pueblos surrounding the Pajarito Plateau suffered tremendous population losses. According to published records of the Spanish census of New Mexico, population totals fell from a combined 6,400 in Jemez, San Ildefonso, Santo Domingo, Santa Clara, and Cochiti Pueblos in 1630 to 1,374 in 1821 (Simmons 1979b).

Mexico was granted independence from Spain with the signing of the Treaty of Córdoba in 1821. The treaty granted full Mexican citizenship to all American Indians (Kessell 1979). The quarter-century of Mexican administration in New Mexico was not marked by any major changes in the legal or cultural affairs of the state. However, it did open up major new trade routes and commerce between Santa Fe and the U.S. By 1824, New Mexicans were, for the first time, buying more from U.S. merchants than from their traditional Chihuahuan sources, and the Santa Fe Trail became important for U.S. traders selling goods to Mexico (Jenkins and Schroeder 1974).

Use of the Pajarito Plateau during the Spanish Colonial and Territorial Periods is not well documented (LANL 1995c). Grazing, seasonal gathering of firewood and timber, and hunting were probably practiced by the growing Hispanic population and by the nearby American Indian communities.

E.3.2.2 Early U.S. Territorial/ Statehood Period (A.D. 1849 Through 1942)

U.S. Army General Stephen Watts Kearny occupied New Mexico when the Mexican War broke out in 1846. The Pueblos of the Rio Grande Valley and the rural Spanish culture of northern New Mexico had become accustomed to changing political authority in Santa Fe and

generally did not resist the change in power. However, in 1847, a rebellion broke out at Taos Pueblo. The brief revolt was bloody and rapidly put down by the U.S. Army (Jenkins and Schroeder 1974). The Treaty of Guadalupe-Hidalgo (1849) formally ended the question of authority in New Mexico and the new administration soon took effect. U.S. policy toward American Indians, including lands and citizenship, was very different from that of Spanish or Mexican administrators. The cornerstones of U.S. American Indian relations were isolation of tribes into separate reservation lands and provision of military protection and education. The first American Indian agent was assigned to New Mexico in 1849, as part of the territorial administration. In the shaping of the first steps toward statehood, the original Spanish and Mexican land grants in New Mexico were formally recognized (Leonard 1970 and Carlson 1990).

The early U.S. homesteaders may have informally begun using the Pajarito Plateau shortly after the U.S. Territory was established by the *Homestead Act of 1862*, which officially opened any untitled lands in New Mexico to settlement. By 1890, the Pajarito Plateau was still only sparsely settled by Hispanic and Anglo homestead ranches (Seidel 1995). The remains of these homesteads usually consist of wooden cabins, corrals, rock and cement cisterns, and agricultural debris such as barbed wire, wagon parts, horseshoes, and other evidence of livestock raising and transportation methods.

Since 1900, the remote and scenic location of the Pajarito Plateau has attracted outdoorsmen for hunting and fishing. The Jemez Mountains and antiquities of the Pajarito Plateau brought many visitors to the area once BNM was established in 1916 (Seidel 1995). The present site of Los Alamos was purchased in 1917 by Ashley Pond. In 1918, Pond established the Los Alamos Ranch School, a private boys' school. The school specialized in residential secondary education and attracted many young men from wealthy eastern families seeking robust physical

development as well as academic education (Seidel 1995). The main recreation lodge and dining hall of the school, Fuller Lodge, is now part of a National Historic District and is a registered national historic landmark. The lodge, built in 1928, is constructed of logs and was designed by John Gaw Meem. The school operated from 1918 until 1943, when the facilities were acquired by the U.S. government for the Manhattan Project (Seidel 1995).

E.3.2.3 Nuclear Energy Period (A.D. 1943 to Present)

Because of very well-defined changes in the function of LASL/LANL, the Nuclear Energy Period is further broken into three periods: World War II/Early Nuclear Weapon Development, Early Cold War, and Late Cold War.

World War II/Early Nuclear Weapon Development Period (A.D. 1943 Through 1948)

The latest era in the historic development of the LANL region began in 1943 with the purchase of the Los Alamos Ranch School by the Secretary of War, as part of the wartime effort to build a secret nuclear weapons program (Seidel 1995). LASL was involved from the very inception of the U.S. government's program to develop nuclear weapons for the war effort (Truslow 1991). LASL was not only representative of wartime research and development facilities, but it provided innovative scientific and technological research and development activities for the U.S. nuclear weapons program from 1943 until the end of the Cold War in 1989. Los Alamos was the original site selected for the design and construction of the first nuclear bomb because of its remote and secret location (Truslow 1991).

The Los Alamos Early Nuclear Weapon Development Period facilities at LASL were built and used in the creation of the first atomic

bomb, which was detonated successfully in July 1945. The design and manufacture of the Trinity bomb; the Hiroshima bomb, Little Boy; and the Nagasaki bomb, Fat Man; took place at LASL (Truslow 1991). LASL and the Trinity Test Site near Alamogordo, New Mexico, represent World War II nuclear weapon development events of exceptional importance on an international scale.

World War II research and development activities were concentrated around the Los Alamos Boys Ranch School, which became the living center for scientists during the war. Laboratories were erected at more remote locations. The S-Site, for example, was developed for high explosives research (Truslow 1991). This set a pattern for later development at LASL, where housing and administration remained concentrated around the present Los Alamos townsite and the former site of the Los Alamos Boys Ranch School. A back gate was erected to control access to the remote laboratories of the S- and V-Sites (Truslow 1991). From 1946 through 1950, all nuclear weapons were made at Los Alamos (DOE 1995). Common remains from this period and the following Early Cold War Period consist of laboratory and administration buildings, security facilities, experimental areas, infrastructure support facilities, berms and barricades, and paved and unpaved roads.

Early Cold War Period (A.D. 1949 Through 1956)

The mission of nuclear weapons development did not end with the close of World War II. In 1946, the Atomic Energy Commission (AEC) became the administrator of LASL, and nuclear weapons research and development continued (Seidel 1995). The Early Cold War Period began when the Union of Soviet Socialist Republics (U.S.S.R.) exploded its first atomic bomb in 1949 and the U.S. government became dedicated to nuclear weapons development and production in a nuclear arms race (LaFeber 1993). The Early Cold War Period

was characterized by international tensions, armament buildup, and mostly military conflict by proxy waged in remote areas of the developing world.

LASL was the first, and later, one of only 13 sites in the U.S. devoted to nuclear weapons development and production (Seidel 1995). During the Early Cold War, LASL became a primary research and development center for U.S. nuclear programs, while production was shifted to other facilities. The period from 1949 to 1956 brought a considerable amount of new construction to LASL to meet the research needs of rapid nuclear armament buildup and international tensions between the U.S. and the U.S.S.R.

From 1943 until 1957, the entire Pajarito Plateau was shielded from public access. Los Alamos was closed and the mission and activities at LASL were classified (Seidel 1995). The city had grown to approximately 5,000 scientists and their families by 1945. In 1941, Los Alamos County was partitioned from Sandoval County and Santa Fe County, with the AEC controlling nearly all acreage in the new county (Seidel 1995).

Late Cold War Period (A.D. 1957 Through 1989)

In 1957, parts of the Pajarito Plateau, including the Los Alamos townsite, were opened to the public, marking the beginning of the Late Cold War (Seidel 1995). Throughout the Cold War, the LASL mission continued to be one of innovation and the scientific development of more powerful and efficient nuclear weapons and delivery systems. The Late Cold War was marked by more diversified research goals. Several periods of construction have occurred at LASL since 1956, but have yet to be analyzed. In 1977, the present boundaries were established, the name was changed to LANL (Steen 1977), and management of LANL was awarded to the University of California (UC) (Seidel 1995).

The international events that may be reflected in the physical record at LANL during this period include (DOD 1993):

- 1957. First underground nuclear test, first intercontinental ballistic missile (ICBM) developed, first successful test of Atlas missiles.
- 1958. First Nike-Hercules missile.
- 1961. U.S. resumes underground testing of nuclear weapons; U.S.S.R. resumes atmospheric testing.
- 1962. East-West conference on banning nuclear weapons tests takes place; U.S. resumes atmospheric testing of nuclear weapons.
- 1967. Treaty of Tlatelcoco prohibits introduction and manufacture of nuclear weapons in Latin America (signed by all Latin American countries except Cuba).
- 1968. Nuclear Arms Non-proliferation Treaty signed by U.S., U.S.S.R., and 58 other nations.
- 1970. Nuclear Arms Non-proliferation Treaty goes into effect.
- 1976. U.S. and U.S.S.R. sign peaceful nuclear explosions treaty limiting testing.
- 1979. North Atlantic Treaty Organization (NATO) announces “dual-track” intermediate-range nuclear forces to intercept Warsaw Pact SS-20 missiles.
- 1983. Congress authorizes MX missile procurement and development; Scowcroft Commission calls for modernizing U.S. strategic weapons.
- 1985. Nuclear and space talks open in Geneva.
- 1986. Peacekeeper ICBM becomes operational.
- 1987. U.S. and U.S.S.R. sign Nuclear Risk Reduction Agreement, eliminating intermediate range nuclear weapons.
- 1989. Fall of the Berlin Wall.
- 1991. Presidents Bush and Gorbachev sign Strategic Arms Reduction Treaty (START); dissolution of the Warsaw Pact.

LANL’s nuclear mission continued to be the primary focus of Los Alamos County until the end of the Cold War in 1989, creating a uniquely specialized scientific community in this remote region of New Mexico. The fall of the Berlin Wall in 1989 and the dissolution of the Warsaw Pact in 1991 effectively ended the international tensions that drove the nuclear development mission at LANL (DOD 1993).

E.3.3 Traditional Cultural Background in the LANL Region

A TCP is a significant place or object associated with historical and cultural practices or beliefs of a living community that is rooted in that community’s history and is important in maintaining the continuing cultural identity of the community (Parker and King 1990). TCPs are essential in preserving cultural identity through social, spiritual, political, and economic uses. Federal guidelines established by the NPS (Parker and King 1990) identify TCPs to include

- Natural resources.
- Prehistoric and historic archaeological sites.
- Traditional use areas in the cultural landscape that do not reveal evidence of human use.
- Rural communities whose organization, buildings and structures, or patterns of land use reflect the cultural traditions valued by its long-term residents.
- An urban neighborhood that is the traditional home of a particular cultural group and that reflects its beliefs and practices.
- A location where a community has traditionally carried out economic, artistic, or other cultural practices important in maintaining its historical identity.

For TCPs on other lands, tribal rights have been established in the federal decision-making

process. SWEIS consultations have been conducted in accordance with applicable federal requirements to include NHPA (16 U.S.C. §470), NAGPRA, *American Indian Religious Freedom Act* (AIRFA) (42 U.S.C. §1996; EO 13007), and DOE and LANL Accord Agreements with the Pueblo de Cochiti and the Pueblos of Jemez, Santa Clara, and San Ildefonso (DOE et al. 1992).

TCPs are not limited to ethnic minority groups, and traditional cultural contexts of northern New Mexico include cultural groups other than American Indians. Americans of every ethnic origin have properties to which they ascribe traditional cultural value. The Hispanic culture, in particular, has maintained traditional communities, practices, beliefs, and subsistence patterns in northern New Mexico.

E.3.3.1 *American Indian Cultures in the LANL Region*

The diversity of American Indian traditional cultural practices in the Southwest is reflected in the number of languages and complex cultures that occur there. Language is essential to the preservation of these cultural practices.

There are five different language families in the LANL region: Tanoan, Keres, Zuni, Uto-Aztecan, and Athabaskan (Hale and Harris 1979). These languages are presented in Table E.3.3.1–1 to show the relationships among the American Indian communities that speak each of the languages. The diversity of the languages also illustrates the complexity of multicultural relations in the region.

Every recognized American Indian community is a sovereign nation with limited powers. In accordance with the DOE American Indian

TABLE E.3.3.1–1.—Languages of American Indian Communities within the LANL Region

LANGUAGE FAMILY	SUBFAMILIES	COMMUNITIES THAT SPEAK THE LANGUAGE	
Tanoan	Tiwa (Northern and Southern dialects)	Pueblo of Taos Pueblo of Picuris	Pueblo of Sandia Pueblo of Isleta
	Tewa	Pueblo of San Juan Pueblo of Santa Clara Pueblo of San Ildefonso	Pueblo of Pojoaque Pueblo of Nambé Pueblo of Tesuque Arizona-Tewa
	Towa	Pueblo of Jemez	
Keres	(Eastern and Western dialects)	Pueblo de Cochiti Pueblo of Santo Domingo	Pueblo of Santa Ana Pueblo of San Felipe Pueblo of Zia
Zuni		Pueblo of Zuni	
Uto-Aztecan	Shoshonean	Hopi Tribe (Several villages on the First, Second, and Third Mesas, Arizona)	
Southern Athabaskan	Eastern Apache	Jicarilla Apache Tribe	Mescalero Apache Tribe
	Western Apache	Navajo Nation (Navajo language)	

Source: Hale and Harris 1979.

Policy, DOE interacts with federally recognized tribes on a government-to-government basis (DOE 1994). In 1992, DOE and the Pueblos of San Ildefonso, Santa Clara, Cochiti, and Jemez, which are located near or directly adjacent to LANL, entered into formal agreements called Accords. The purpose of the Accords was to improve communication and cooperation among federal and tribal governments. In 1994 and in 1996, the Pueblos of San Ildefonso, Cochiti, Jemez, and Santa Clara also signed cooperative agreements with DOE and UC to promote a meaningful participation and consultation on Pueblo environment, safety, health, and religious-culturally significant matters. The Accords and cooperative agreements are discussed further in chapter 7, section 7.2.9.

In Apache and Navajo communities (Athabaskan cultures), tribal governments are based on the electoral process. Tribal members select a president and vice president during the summer for a 4-year term of office. The Navajo Nation has 110 political subdivisions, called “Chapter Houses” (e.g., Alamo, Cañoncito), that are represented in the Council. Initially, federal agencies must consult with the President of the Navajo Nation directly, but later requests may be referred to specific tribal departments or chapters.

The role of tribal governments is to interact with outside organizations such as county, state, and federal bureaucracies on a variety of issues. These issues include casinos and economic development, litigation, tribal court systems, land claims, hazardous waste transportation through tribal lands, construction projects compliance with tribal environmental standards, Indian health clinics, grave repatriation issues, language preservation programs, and cultural resources management.

E.3.3.2 *Traditional Hispanic Communities in the LANL Region*

LANL is located near numerous traditional Hispanic communities in four counties: Santa Fe, Sandoval, Rio Arriba, and Taos. While many of the cultural characteristics and demographics of the larger towns and cities of northern New Mexico have changed in recent years, many small, rural, and primarily Spanish-speaking communities, identified as traditional communities, continue to exist. Many communities were first settled during the Spanish Colonial Period and were given their land by the Spanish Crown (Weigle 1978). The identity of traditional Hispanic communities is maintained partly through archaic linguistic patterns and vocabulary carried over from early Spanish colonization of the area and partly through the traditional beliefs and practices unique to the region. Traditional Hispanic communities in northern New Mexico also maintain religious practices, art and craft traditions, folklore, and traditional medical practices (Ahlborn 1968, Briggs 1980, Weigle 1978, and Carlson 1990).

A traditional element present in these communities is the use of shared community ditches, or acequias, for irrigation (Carlson 1990). For that reason, these communities are sometimes known as acequia communities. (Campa 1979). Acequias are not only ditches but also traditional cultural systems that organize allocating, distributing, and sharing water in an arid land. Acequia systems are governed by traditional practices that are derived from Spanish Colonial laws of the seventeenth and eighteenth centuries (Weigle 1978 and Carlson 1990). The social labor systems necessary to operate the ditches include commissioners (elected representatives), mayordomos/mayordomas (ditch managers), and *parcipiantes* (landowners/shareholders) (Meyer 1984). Acequias are also political subdivisions of the State of New Mexico,

recognized for their role in the development and administration of water resources for irrigation. The acequia system in the region is also closely intertwined with the Catholic Church.

E.3.3.3 *Traditional Cultural Property Categories*

Because of the numerous traditional cultures present in the region, the discussion of TCPs will be based on resource categories as well as the particular cultural affiliation of the community. The traditional cultures of the region have had many generations of interaction with one another and often have overlapping subsistence, artistic, and religious practices with unique cultural importance attached to similar types of sites. Several general categories of TCPs have been identified in the literature on American Indian and Hispanic cultures in northern New Mexico. Each of these categories represents specific cultural and physical sensitivity and susceptibility to adverse impacts from LANL operations. TCP resource types or categories in northern New Mexico include:

- Ceremonial and archaeological sites
- Natural features mentioned in stories, myths, and legends
- Ethnobotanical plant-gathering sites
- Artisan material-gathering sites
- Places used in traditional subsistence activities

These resource types are described in the following subsections, providing an overview of the range and diversity of potential TCPs in northern New Mexico.

Ceremonial and Archaeological Sites

Religious and ceremonial sites may be TCPs if they are still a part of the living memory and practices of traditional communities. Both American Indian and Hispanic communities have many ceremonial sites in northern New Mexico, including American Indian shrines and

places of ceremony, Hispanic shrines, sanctuaries and meeting houses of the Catholic lay-brotherhood, known as Los Hermanos Penitentes.

American Indian groups visit and use a variety of ceremonial sites and shrines that are part of the landscape. The locations of tribal ceremonial sites and shrines are often held in secret by religious societies in the Pueblos (Starr 1900). Some American Indian ceremonial sites are marked with stones or other man-made features, while others are preserved in the living memory of the societies that visit them (Harrington 1916 and Douglas 1917). Some sites are visited only on rare occasions as particular circumstances demand it (Lange 1959 and Nordhaus 1995). The locations of some shrines have been previously published, but in the interest of preserving the privacy of the tribes, only general locations have been indicated throughout this technical report.

Most American Indian ceremonial sites remain unrecorded. Examples of recorded American Indian ceremonial sites within or near LANL boundaries include shrines that are known to exist around Mount Pelado, Redondo Peak (Akins 1993 and Ellis 1979); around Ovahwi Peak, Capulin Canyon, and Black Mesa (Akins 1993, Harrington 1916, and Douglas 1917); and along the Rio Grande, Tsikomo Peak, Nipple Mountain, Potrero de los Idolos, Peña Blanca, and Canada de Peralta. Shrines are also recorded for several caves in the area (Akins 1993, Harrington 1916, and Lange 1959).

Sanctuaries, shrines, and religious structures dating from the Colonial Period in New Mexico, are still widely revered and used by traditional communities, both Hispanic and American Indian. These sanctuaries may be completely ruined at this time or may have been extensively restored. The Santuario de Chimayo is widely visited by pilgrims from traditional Hispanic villages around New Mexico (Treib 1993). Sanctuaries at Cochiti, Santa Domingo, San Felipe, Zia, and Picuris Pueblos are enduring

locations of traditional ceremonial practice (Treib 1993). The Oratorio of San Ysidro, the sanctuary of San Vicente De Paul in Punta de Agua, the church of San Miguel in La Bajada, and the church of San Jose de Gracia de Las Trampas are other examples of important Hispanic sanctuaries (Treib 1993). The ruins of San Jose de Giusewa in Jemez Springs are no longer in use as a sanctuary, but remain part of the continuing Catholic traditions of the Jemez Valley.

Moradas are ceremonial features unique to the Spanish traditions of northern New Mexico (Ahlborn 1968 and Wallis 1994). These structures serve as chapter houses for the lay-brotherhood of La Fraternidad Piadosa de Nuestro Padre Jesus Nazareno, also known as Los Hermanos Penitentes (Wallis 1994). Los Hermanos Penitentes originated in Spanish Colonial New Mexico and were formally organized between 1776 and 1833 during a period when there were insufficient priests to serve the needs of the Hispanic communities. The village moradas still serve to bring the traditional Hispanic community together and preserve teaching and values unique to the region through their community meetings, teachings, and ceremonies (Ahlborn 1968 and Wallis 1994).

Community members who move away for work often return for annual ceremonials that provide continuing identity with their Spanish ancestors. One Penitente writes,

I am a member in good standing in the Brotherhood as were my forefathers, yet as is true of many Brothers of my generation, I no longer live in the village of my ancestors. Still I always return to the Morada. The Morada is a symbol of continuity, a reminder that those who went before us made many sacrifices to maintain something for succeeding generations (Wallis 1994).

Ancestral villages, archaeological sites, and petroglyphs, so numerous in the LANL region, are considered sacred areas by American Indian tribes. Pueblo de Cochiti inhabitants, for example, have many stories about their ancestors and the ruins in the region. Their stories indicate that originally all their people came up from Shipap (an unknown place of great antiquity) and lived together on the Mesa of the Stone Lions (Frijoles Canyon) in different villages: White House and the Village of the Two Lions (Benedict 1931, Akins 1993, and Douglas 1917). Then, the people split apart and the Santo Domingo went down the east bank of the Rio Grande to Cactus Village while the people of San Felipe, Laguna, and Acoma traveled west, down Peralta Canyon, and built the Pueblo of Peralta Canyon (Benedict 1931, Lange 1959, and Akins 1993). At the same time, the people of Cochiti went down Kapolin Canyon to settle in San Miguel on the west side of the river. Hainayasta and Tiputse are mentioned as Cochiti villages “across the river.” Later the Pueblo de Cochiti people came from San Miguel to the “Plateau of the Buildings” where a new Pueblo was built. They lived there many years before coming down from the plateau (Benedict 1931 and Akins 1993).

Each of the physical places mentioned in such legends is a sacred link between the traditional community and the lives and traditional ways of their ancestors. The importance of ancestral villages is often reinforced by ceremonies held at ancestral ruins (Douglas 1917 and Akins 1993).

Natural Features

A variety of features in the landscape have special meaning for traditional cultures of northern New Mexico because of their association with the stories, myths, and legends that are shared by the community. Sites in this category may not need to be visited on a regular basis to retain cultural value and, in fact, may be inaccessible. The cultural value derives from the knowledge of their existence in relation to

the ongoing history and values of the community.

Some natural features may resemble an animal, person, or mythological creature, and traditional stories may explain their existence and relationship to the traditional culture. Examples of this resource category include Camel Rock on Pueblo of Tesuque tribal lands and Black Mesa on Pueblo of San Ildefonso tribal lands. Black Mesa is known in stories as the home of Tsah-ve-yoh, a dreaded child-eating giant from Tewa stories, who returns to the surrounding Pueblos every year at Christmas time to whip any bad children who do not behave (DeHuff 1931). The same feature is also known from Tewa legends as a stronghold to which the people fled during the Navajo siege of ancient times and again when the Tewa were besieged by the Spaniards in 1694 (DeHuff 1931). Black Mesa does not have to be visited to maintain cultural value for the communities; its visibility is a daily reminder to children of the need to be obedient members of the Pueblo and of the bravery of their ancestors. Camel Rock, along U.S. Highway 84 between Santa Fe and Pojoaque Pueblo, is likewise a TCP that is mentioned in stories of the Tsah-ve-yoh. It is told that the giant would take four long strides from Black Mesa to Pojoaque to grab up the children of the Pueblo, then sit down on the rock formation (Camel Rock) to eat them alive (DeHuff 1931).

Stories and myths of Pueblo de Cochiti mention other prominent natural features: “Cave Place” and Peralta Canyon are mentioned in stories as places where giants lived. The giants are known to carry Cochiti children from the old Pueblo at Hainaysta (across the river from the modern Pueblo) through “Fissure Place” and to the “Giants Boiling Place.” One giant, Schkoio schkaka haush, is known in myths to have been killed and shut up in his cave (Benedict 1931). Another natural feature is the “Stone Lions,” a stone carved to resemble two resting lions, which gives the name “Village of Stone Lions”

to an ancient Pueblo on the mesa above Frioles Canyon (Hendron 1946 and Benedict 1931).

Mountain peaks, lakes, springs, and petroglyphs are often natural features in the sacred legends of traditional cultures in northern New Mexico (Akins 1993). Sacred peaks are part of the iconography of the Navajo Nation and of the Jicarilla Apache Tribe (Nordhaus 1995). Peaks sacred to the Tewa tribes include Conjilon, Chicoma Mountain, Sandia Crest, Truchas Peak (Friedlander and Pinyan 1980), San Antonio Peak, Lake Peak, and Cerro Pelado (Hewett and Dutton 1945). Sandia Pueblo considers Puye National Monument pictographs to be sacred to the tribe (Parker 1993). Hewett and Dutton reported in 1945 that the San Ildefonso and other Pueblos hold five area lakes and springs to be sacred (Hewett and Dutton 1945). These springs and lakes mark the four directions around San Ildefonso.

Ethnobotanical Gathering Sites

American Indian and traditional Hispanic communities rely on the use of wild native plants for ceremonial and medicinal purposes such as foods, dyes, and utilitarian objects (Dunmire and Tierney 1995, Robbins et al. 1916, and Toll 1992). Through the everyday use of native plants, there is a sense of connection with the land and continuity with the previous generations who were part of the land (Ford 1976, Cajete 1994, and Wetterstrom 1986). The continued use of botanicals in traditional cultures confirms a body of unwritten knowledge about the values and purposes of plants as part of a particular worldview or belief system unique to each culture (Wetterstrom 1986 and Toll 1992). This subsection contains information regarding plants that are ingested or used for ceremonial purposes. Plants used for dyes, construction, and other utilitarian purposes will be discussed as artisan materials in the following subsection.

American Indian ceremonies make use of specific wild plants and cultivated plants as

foods, beverages, smoke, and coloring agents, or for ritual chewing. They are also incorporated into ceremonial implements or objects (Hiles 1992, Moerman 1986, and Dunmire and Tierney 1995). One such example of ceremonial use occurs each year at Sandia Pueblo when bundles of wood and snakeweed are taken to the cacique or Pueblo leader. This is done for 12 days following the winter solstice in ceremonies to nurture and bless the village (Dunmire and Tierney 1995). The use of smudges of big sage is recorded from Jemez Pueblo and the Navajo Nation for fumigating and purifying houses (Young 1940 and Dunmire and Tierney 1995). Douglas fir boughs and branches are incorporated into the traditional dances of several Rio Grande Pueblos (Dunmire and Tierney 1995), and cattails are also frequently featured in Pueblo ceremonies because of their symbolic association with water (Ford 1968 and Robbins et al. 1916). Navajo ceremonies use several plants such as bitterball and ironwood (Young 1940 and Elmore 1944). Ceremonial use of plants may require that they be gathered from specific places in order to increase their potency or ritual significance (Ford 1968). Pueblo practices may require ritualized gathering of medicinal plants and wild foods or may be undertaken only by certain sodalities (Ford 1968).

It is uncertain from the literature if there are Hispanic ritual or ceremonial uses for plants. Knowledge about the use of native food plants was undoubtedly shared among the Pueblo cultures and the Spanish colonists, for Hispanic knowledge and use of native plants for food and medicine overlaps a great deal with Pueblo uses. Pueblo uses of wild plants also seem to have been altered by Spanish contact (Toll 1992 and Ford 1968).

The Rio Grande Pueblo people gather many wild plants as foods and beverages (Dunmire and Tierney 1995). Documented food use includes three-leafed sumac, acorns from Gambel's oak, and ripe fruit from the

chokecherry, gooseberry, and currant. Since ancient times, the fleshy fruit of the banana yucca has continuously been harvested and used as food by Pueblo people (Minnis 1991, Ford 1968, Toll 1983, and Toll 1992). The use of Indian tea is also very common as a beverage among Pueblo, Navajo, Apache, and Hispanic people in the region (Dunmire and Tierney 1995, Moerman 1986, and Elmore 1944). Prickly pear fruit, Indian rice grass seeds, and tubers of wild potato are believed to have been important "famine foods" of the region in past times of drought and may still be gathered and encouraged to grow near Pueblos (Minnis 1991). Pinyon nuts are the most important of all wild food sources for Pueblos and traditional Hispanic communities in the region. Families will frequently travel great distances to collect nuts in the autumn, and individuals may gather and sell the nuts in their communities (Ford 1968 and Dunmire and Tierney 1995).

Medicinal use of wild plants is common in northern New Mexico among the Pueblo, Apache, and Navajo people and traditional Hispanics. Dunmire and Tierney (1995) assert that 180 different species of wild plants in the region have medicinal uses among 1 or more of the 19 New Mexico Pueblos. Regular medicine gathering trips are conducted to the Pajarito Plateau and other high elevation sites by the Pueblo's medicine societies (Dunmire and Tierney 1995 and Ford 1968). Commonly known medicinal plants include joint-fir, broom snakeweed, sage, and four-o'clocks (Dunmire and Tierney 1995 and Curtin 1947). Osha root is also an important medicinal plant used by American Indians and Hispanics in the region (Ford 1968, Hiles 1992, and Dunmire and Tierney 1995). The locations of collection areas for some of the rarer medicinal plants that grow in the mountains, such as Osha root, may be a closely kept secret of village healers.

Artisan Material Gathering Sites

The gathering of raw materials for numerous commercial and non-commercial utilitarian

objects is common in the American Indian and Hispanic traditional communities. While some utilitarian objects, such as handmade plant fiber cordage, woven yucca sandals, and wooden arrowheads, have generally been replaced by modern products, there are still enduring traditions of weaving, tanning, wood carving, jewelry making, joinery and construction, and pottery making that use native materials gathered locally. The products of these traditional arts have become internationally prized not only because of the aesthetic quality they demonstrate, but also because of their continued use of native woods, fibers, dyes, and minerals. The continued access of traditional communities to the natural resources of the region is vital to the continuation of these traditional arts.

The use of natural dyes, pigments, and tanning agents is still a characteristic of traditional American Indian and Hispanic communities in northern New Mexico (Dunmire and Tierney 1995 and Dickey 1990). Weaving is a very important traditional art form, and many traditional weavers still produce dyes from native plants they have gathered locally (Dickey 1990, Minge 1979, and Dunmire and Tierney 1995).

Three of the important dyes used by traditional Hispanic weavers are imported from Mexico: indigo, cochineal, and brasilwood (logwood) (Anonymous 1976 and Minge 1979). Other important dye-producing plants are gathered from village roadsides, acequia banks, mountain habitats, or the nearby desert (Dunmire and Tierney 1995 and Dickey 1990). These plants include goldenrod, cocklebur, sumac, sunflower, dahlia, chokecherry, chamisa, snakeweed, slatbush, mountain mahogany, oak and alder bark, lichens, caniegra, Virginia creeper, cota or Indian tea, juniper, madder, black walnut, onion skins, and marigold (Anonymous 1976, Minge 1979, Dunmire and Tierney 1995, and Young 1944). Rocky mountain beeplant, wild dock, pinyon pitch, and tansy mustard are used for pottery paints

(Dunmire and Tierney 1995), and red clay is sometimes used as a red fabric dye (Young 1944).

Construction woods and adobe clays are also gathered from sources in northern New Mexico. Pueblo and traditional Hispanic construction uses whole logs for vigas (roof beams) made of cottonwood, Ponderosa pine, and Douglas fir (Dickey 1990 and Dunmire and Tierney 1995). Latillas (roof cross-supports) are usually made of split aspen, mountain-mahogany, or oak; roof thatching is made of four-winged saltbush or common reeds (Young 1944, Dickey 1990, and Dunmire and Tierney 1995).

Adobe clay is gathered from many sites near Pueblos and Hispanic villages and mixed with dried plants to form the walls of most buildings in traditional communities (Dickey 1990, Weigle 1978, and Hill 1982). Potter's clay, however, comes from very specialized sites that contain very fine clays without impurities (Dickey 1990 and Peterson 1977).

Wood carving is an artistic tradition in some Hispanic communities (Briggs 1980), and carved wooden Santos are an important tradition of the local churches and Moradas (Dickey 1990 and Briggs 1980). Santos are carved depictions of the saints and allegorical stories in the Catholic traditions and traditionally are of two forms: bultos, or three-dimensional carvings; and retablos, or bas-relief carvings on hinged wooden panels (Briggs 1980). The wood may be augmented with gypsum, metals, and other materials. Paints were originally of natural pigments, but increasingly include commercial products (Briggs 1980). Native wood of outstanding carving characteristics is gathered from the national forests. Preferred wood comes from aspen, berried juniper, willow, and pine (Briggs 1980).

Drums and many other articles are carved from the aspen and cottonwood found in the Pueblo communities (Dunmire and Tierney 1995), and

bows are made from pliable woods such as wild currant, New Mexico locust, and chokecherry (Dunmire and Tierney 1995). Arrows are crafted from various woods and common reeds. Apache plume is most commonly used for making brooms (Dunmire and Tierney 1995).

E.3.3.4 *Traditional Subsistence Features*

Traditional subsistence practices in use in northern New Mexico include community-maintained irrigation ditches, called acequias, traditional trails and hunting areas, traditionally used fields, grazing areas, firewood-gathering sites, and Spanish land grants. While subsistence functions may not be unique to tribal or Hispanic communities, the traditional community is often brought together and identified through their annual subsistence cycle, and these subsistence activities reinforce a world-view and values unique to the community. As such, the protection of these properties ensures the ability to continue traditional community values and identity.

Acequias are the best known example of traditional subsistence features in northern New Mexico. Acequia communities are complex social institutions that have developed around the Hispanic water supply and irrigation systems known as the Acequia Madre (Arellano 1994). Irrigation systems require not only a sedentary lifestyle but also a complex system of social participation and control because of the intense labor required to build, maintain, and regulate them. Many areas in the arid southwest have developed unique traditional practices surrounding the acquisition of water rights and the development and use of irrigation systems. In northern New Mexico, the acequia communities have developed through the commingling of Pueblo and Spanish traditions and the particular demands of the environment (Campa 1979 and Jenkins 1972).

The fertile flood plains of northern New Mexico required tapping the rivers for a reliable water supply for people, crops, and livestock. Wide fluctuations in annual rainfall characterize the region, making the regulation of hydrological systems essential for a sedentary population (Ackerly et al. 1993). Irrigated agriculture, including terraces and reservoirs, has been present in the Rio Grande Valley since A.D. 1400. The Tewa Pueblos produced crops of maize, squash, beans, melons, cotton, and chile using simple but effective irrigation techniques (Arellano 1994). In an early expedition into northern New Mexico, Antonio Espejo observed the agricultural systems at Acoma Pueblo, stating that they had "... found many irrigated corn fields with canals and dams" (Hammond and Rey 1966).

The Spaniards were already familiar with a variety of irrigation techniques dating back to the Roman and Moorish civilizations. In the years after Spanish settlement of northern New Mexico, they augmented native methods of irrigation with those brought from the Iberian peninsula, including social community cooperation and control mechanisms. Eventually, the physical and social practices of Hispanic irrigation became codified legal institutions as well as traditional cultural systems. These are still reflected in New Mexico water law, as well as in the traditional practices of some Hispanic communities.

Acequia systems did not develop without a good deal of contention and social conflict. Spanish and Pueblo traditions differed considerably in the cultural perspective on the relationship of water, religion, and society. Early Spanish water tradition was relatively compatible with Pueblo traditions in that water resources were considered to belong to the community rather than the individual (Ackerly et al. 1993). The concept of the community gradually gave way to privatization and the pursuit of private wealth in the New World (Meyer 1984). Conflicts over water rights and the shared responsibility for acequia maintenance among the Spanish

Colonials increased over time, as did conflicts over water rights between acequia users and neighboring Pueblos.

Article 6 of the *Plan de Pitic*, 1789, specified that all new lands in the northern provinces, subject to irrigation, would receive equal benefits of water from the Acequia Madre through individual outlets and ditches (Meyer 1984). Each landowner, or *parcipiante*, was to be informed of his outlet location and was not to abuse any neighbor's access to water. Outlets were to be made of stone and mortar, at the individual's expense, to prevent losses to downstream users. Article 19 of the *Plan de Pitic* specifies the fair apportionment of water to the community. Responsibility is given annually to the town council to appoint an overseer, called the *alcalde* or *mayordomo*, for each outlet of the Acequia Madre. This person was to apportion the water to all fields in proportion to the needs of each, with each individual landowner having posted hours for irrigation. The *alcalde* was authorized to hire an assistant to check the outlets for compliance at the proper times and to charge a fee to the landowner if the assistant was required to open the outlet for him. This basic political/agricultural institution has been followed by Hispanic and Hispanic-influenced communities in Texas, California, parts of Colorado and Arizona, as well as throughout New Mexico (Meyer 1984).

The affairs of the acequia are handled in many Hispanic areas of New Mexico at meetings of *La Junta del Agua*, a problem-solving-oriented assembly of landowners. This tradition dates back to the *Tribunal de las Aguas*, which met regularly since the Middle Ages on the steps of the Cathedral of Valencia, Spain, (Campa 1979). The members of *La Junta del Agua* were respected members of the community. Within this context, important issues of water rights and local power were decided. All the landowners using water from the Acequia Madre still gather in the spring with horses, scrapers, and manpower to clear out debris and rocks and to

make any necessary repairs (Meyer 1984). This communal activity, guided by the *mayordomo*, is called *La Fatiga* in New Mexico and is often a significant community event for Hispanic villages (Campa 1979).

Pueblo irrigation predates Spanish contact. Centuries of excavation, routine maintenance, and repairs mask any clear-cut evidence of their prehistoric origins (Ford 1976 and Meyer 1984). Acequias are integral to the technological and ceremonial life of the Pueblo. Their use, while very similar to the use in the Hispanic communities, is punctuated by religious and ceremonial events unique to each Pueblo (Ford 1968, Ford 1976, and Hill 1982).

Land grants form the basis of title and land use for many of the traditional communities in northern New Mexico. Land grants were dispensed by the Spanish Crown and Mexican government to the Pueblos and to Spanish settlers "to advance civilized life" in the region. The land grants were of three types: those for individual tracts of irrigable farmland, those that were granted as commons or pasture lands for a community, and those that were given to each Pueblo to regulate for their own purposes (Leonard 1970). The Pueblo land grants only affirmed the Pueblos' rights to existing patterns of land use, but the Hispanic land grants, upheld by U.S. law, shaped the lifestyles of traditional communities in the region (Leonard 1970 and Carlson 1990). Modern Pueblos, including their fields and commons, are considered to be TCPs in their own right. Traditional Hispanic land grant communities may also be considered TCPs in that all of the parts (e.g., individual holdings, commons, acequias, village) are interrelated and required for the continuation of the whole (Leonard 1970, Carlson 1990, Ackerly et al. 1993, and Arellano 1994).

An example of an existing traditional Hispanic Land Grant community in the LANL region is the Canyon de San Diego Land Grant near Jemez Springs (Cline 1972). The grant includes 110,000 acres (44,517 hectares) of commons or

grazed community lands and 6,000 acres (2,428 hectares) of individual farms irrigated by acequias (Cline 1972). The individual farms were granted as parcels along the acequia system. Over generations, the allotments have been further divided as a result of inheritance practices into thin parcels called strip holdings or long fields (Carlson 1990 and Cline 1972). Each borders the acequia on a narrow side. The village is thus characterized by the existence of long fields in the bottomland where corn, beans, squash, alfalfa, and other crops are irrigated by the acequias (Carlson 1990 and Weigle 1978). The acequias and the grazing commons are the shared responsibility of the villagers, and the commons provide not only grazing for livestock but also many other natural resources gathered by individual families (Weigle 1978 and Carlson 1990). Pinyon nuts, firewood, construction wood, ethnobotanicals, and other resources come from the commons, which are frequently mountainous (Carlson 1990). The houses and church or Morada of the village are clustered tightly, reducing any waste of valuable bottomland and providing community solidarity. The routine of community life is punctuated by agricultural, irrigation and religious events, and is broken by periodic treks into the mountains to gather wood and other resources. All elements are necessary not only for subsistence but also to maintain a unique cultural identity in the face of the modern cash economy.

Traditionally used trails and hunting areas form another subsistence element of traditional cultures of northern New Mexico, particularly of the American Indians. Communal hunts are conducted by Pueblo sodalities or moieties, which are often ritualized and geographically specific (Ford 1968). The mountains are generally shared territory among several tribes. Not only are they areas to hunt or gather specific plants, but they are also locations of important shrines with ritual obligations for visitation (Ford 1968 and Nordhaus 1995). Trails to hunting sites, ceremonial sites, and grazing

areas were documented for the Jicarilla Apache Tribe (Nordhaus 1995), and Harrington's maps of Pueblo sites also show trails (Harrington 1916). Zuni trails are indicated on a map by Ferguson and Hart (1985). Their trails lead as far as the Great Salt Lake in Utah. The Zuni tribe has also documented ritual hunting areas and deer trap areas (Akins 1993 and Ferguson and Hart 1985).

E.4 FEDERAL AND STATE REGULATIONS RELATED TO CULTURAL RESOURCES AT LANL

The NHPA (16 U.S.C. §470) was passed in 1966. Under the NHPA, federal agencies (in this case, DOE) have specific responsibilities toward cultural resources that are on their lands or that may be affected by their activities. Section 106 of the NHPA requires that DOE take into account the effects of activities on significant cultural resources. DOE is also required to allow the Advisory Council on Historic Places (ACHP) the opportunity to comment on any DOE plan that may affect such resources. Under the ACHP's regulations for implementing Section 106 of the NHPA (published in the Code of Federal Regulations as 36 CFR 800), the ACHP's right to comment is often delegated to the SHPO. The regulations specifically require that DOE identify cultural resources that may be affected by its "undertakings," evaluate the significance of those resources, and assess the effects of its undertakings on those resources. This process must be completed in consultation with the New Mexico SHPO.

Under Section 106, cultural resources are considered significant if they are eligible for inclusion on the NRHP. Federal regulation 36 CFR 60.4 states that cultural resources may be eligible to the NRHP if they meet one or more of the following criteria:

- They are associated with events that have made a significant contribution to the broad patterns of history.
- They are associated with the lives of persons significant to our past.
- They embody the distinctive characteristics of a type, period, or method of construction, or they represent the work of a master; possess high artistic values, and/or represent a significant and distinguishable entity whose components may lack individual distinction.
- They have yielded or may be likely to yield, important information to prehistory or history.

The SHPO and other personnel of the Historic Preservation Division of the New Mexico Office of Cultural Affairs, operate under the NHPA and in particular monitor Section 106 compliance. The Historic Preservation Division also provides technical services, a state-wide database, and Section 106 compliance advisors (18 New Mexico Statutes Annotated [NMSA] §6-1 through 6-17 and 8-1 through 8-8). In addition to assisting DOE in determining cultural resource significance, the New Mexico SHPO is responsible for coordinating state participation in implementing the NHPA (16 U.S.C. §470). The New Mexico SHPO represents the interests of the state and its citizens in the preservation of their cultural heritage and assists DOE in identifying historic properties and assessing impacts of activities. The SHPO may agree or disagree with the responsible agency's assessment of the eligibility of its cultural resources. Ultimately, the determination of eligibility of any cultural resource is made by the keeper of the National Register, DOI (36 CFR 63.2).

To determine the scope of the SWEIS cultural resources evaluation, DOE first met with the New Mexico SHPO. The meeting resulted in a decision that the SWEIS does not, in and of itself, constitute an undertaking; therefore, compliance with Section 106 of the NHPA (16

U.S.C. §470) is not required (PC 1996). However, individual actions covered by the SWEIS might be undertakings requiring Section 106 compliance.

Through development of the LANL SWEIS, the DOE evaluated the potential impacts of proposed actions on cultural resources in order to mitigate impacts, if required, and to ensure compliance with all applicable federal and state requirements.

Of interest in this process are actions that might adversely affect or diminish the integrity of the location, design, setting, materials, workmanship, feeling, or association of a TCP. Adverse effects evaluated for the SWEIS include, but are not limited to

- Physical destruction, damage, or alteration of all or part of the property.
- Isolation of the property from or alteration of the character of the setting when that character contributes to the qualification of the property for nomination to the NRHP.
- Introduction of visual, audible, or atmospheric elements that are out of character with the property or alter its setting.
- Neglect of the property resulting in deterioration or destruction (36 CFR 800.9).

The scientific community has concerns that compliance with federal historic preservation law might impede efforts to remain at the forefront of international research and achievement. In 1989, in response to these concerns, Congress directed the ACHP to study the designation of scientific research institutions as historically significant. Concerns were raised by agencies faced with altering or renovating existing or abandoned research facilities that were considered eligible for the NRHP by the ACHP. The resulting document, titled "Balancing Historic Preservation Needs with the Operations of Highly Technical or Scientific

Facilities,” discusses the needs of research institutions to upgrade their facilities and the responsibilities of preservation agencies to implement the requirements of federal historic preservation regulations (ACHP 1991). The following are among the recommendations outlined in the 1991 report:

- Future authorizations for major scientific and technological programs should include public education components focusing, in part, on the communication of the relevant history of science.
- Decisions about projects that may affect historic properties need to be made with as complete an understanding as possible of those effects. However, considerations of preservation options should be kept distinct from the peer review process of awarding research grants and the determination of research priorities central to the scientific research process.
- The ACHP and affected federal agencies should jointly subscribe to a statement of policy that acknowledges the sensitive relationship between scientific research and the evolving history of science and its physical manifestations.
- Federal agencies should determine how they might better coordinate historic preservation programs and planning among facilities managers, public affairs officers, archivists, historians, external affairs officers, and other staff. The ACHP should recommend measures to these agencies to improve the effectiveness, coordination, and consistency of procedures with the purposes of the NHPA (16 U.S.C. 470 §202[a][6]).
- Future scientific achievement, as well as adequately serving the public interest, depends on an understanding of past scientific successes and failures. Federal agencies, in cooperation with other concerned parties, should explore innovative ways for minimizing and meeting the costs of historic preservation

that may be associated with the operations and management of historic facilities.

- The ACHP, in cooperation with the Smithsonian Institution, the NPS, and federal agencies, should establish a consensus about what kinds of scientific facilities and objects should be physically preserved for the future. This should include deciding how the historic value of facilities and objects can be determined and which facilities and objects can be “preserved” through documentation. The ACHP suggests that the documentation option would be best suited to historic facilities that are still active.

The study concluded that the ACHP regulations and the Section 106 review process are flexible enough to accommodate the legitimate needs of the scientific and engineering community and their activities at historic facilities (ACHP 1991).

The NPS’s *National Register Bulletin 22*, “Guidelines for Evaluating and Nominating Properties that Have Achieved Significance Within the Last Fifty Years” (NPS 1990), emphasizes the importance of carefully establishing the cultural context of properties and evaluating them based on comparisons with other possible properties within the same historical context. A justification or rationale of exceptional importance should be an explicit part of a statement of significance. Such properties frequently qualify for nomination to the NRHP under more than one of the criteria for evaluation for nomination (36 CFR 60.4).

The NPS’s *National Register Bulletin 38*, “Guidelines for Evaluating and Documenting Traditional Cultural Properties” (Parker and King 1990) indicates that objects, trails, pathways, physical features, or resource gathering sites that are significant to a living community’s historically rooted beliefs, customs, and practices, may be eligible for protection under the NHPA. Within LANL’s boundaries, TCPs exist that have both a current

and a traditional importance to existing American Indian and other local communities. Although TCPs have been eligible for the NRHP since its creation (Parker 1993), it was not until *National Register Bulletin 38* was published that their importance was recognized by federal agencies, SHPOs, and other cultural resources managers.

Other pieces of legislation, including the AIRFA of 1978 (42 U.S.C. §1996), the NAGPRA of 1990 (25 U.S.C. §3001), and Executive Order (EO) 13007, deal mostly with religious, ceremonial, or burial sites.

The AIRFA is a joint resolution of Congress stating that the policy of the U.S. is to protect and preserve the right of American Indians to have access to sites, possess and use sacred objects, and worship through traditional rights and ceremonials. The AIRFA is simply a policy statement; no regulations implementing the AIRFA have been promulgated. (However, within DOE, DOE Order 1230.2, *American Indian Policy*, is the implementing regulatory mechanism.)

The NAGPRA places ownership or control of American Indian human remains or funerary objects, excavated or discovered on federal or tribal lands after the date of the act, in the hands of the lineal descendants of the Indian tribe. Moreover, the NAGPRA requires agencies and museums with collections of American Indian human remains or associated funerary objects to inventory those remains; identify their geographic and cultural affiliations, in consultation with tribal governments and religious leaders. They then must provide each Indian tribe with a copy of the inventory of remains associated with that tribe, an inventory of remains not clearly associated, and access to records, catalogues, and studies. If the cultural affiliation is established or demonstrated through “geographical, kinship, biological, archaeological, anthropological, linguistic, folkloric, oral traditional, historical, or other relevant information, or expert opinion”

(43 CFR 10.7[a][4]), the remains must be returned, if requested. The regulations implementing the NAGPRA, published in 1995 (43 CFR 10), provide a systematic process for determining the rights of lineal descendants and Indian tribes to the remains, and instructions for consultation.

Consultation with lineal descendants and affiliated tribes is required at several stages of NAGPRA compliance. Intentional archaeological excavations of human remains, funerary objects, sacred objects, or objects of cultural patrimony on federal lands are permitted only after consultation with appropriate Indian tribes (43 CFR 10.3). Consultation must include any tribes that are likely to be culturally affiliated with or to have occupied the area, or that have a demonstrated cultural relationship to the remains (43 CFR 10.5). Prior notification of Indian tribes who have likely affiliation, have aboriginal use of the area, or who are otherwise culturally related to the remains is required if an activity may result in the excavation of such remains (43 CFR 10.3[c]). Inadvertent discoveries require notification of “likely to be culturally affiliated” Indian tribes within three working days and cessation of all disturbance in the area. In addition, the person or agency responsible for the discovery must protect the site from further disturbance. The project may resume in 30 days after notification unless a plan, such as a memorandum of agreement (MOA) is in place. In the event of emergency discoveries, consultation should be coordinated with the reporting responsibilities of other legislation. Additionally, 43 CFR 10.6 recommends that federal agencies enter into comprehensive agreements with Indian tribes, addressing all federal agency land management activities that could result in the intentional excavation or inadvertent discovery of such remains, and that they establish a process for effectively carrying out the NAGPRA requirements. LANL has completed an inventory in compliance with the NAGPRA;

however, to date, the NAGPRA consultations have included only the four Accord Pueblos.

EO 13007 directs agencies to accommodate access to and ceremonial use of Indian sacred sites on federal lands by Indian religious practitioners, and to avoid adversely affecting the physical integrity of such sites. A sacred site is defined as a “discrete, narrowly delineated location of federal land that is identified by an Indian tribe, or Indian individual determined to be an appropriately authoritative representative of an Indian religion, as sacred by virtue of its established religious significance or for ceremonial use by an Indian religion.” EO 13007 is applicable to some TCPs and adds protection to newly established ceremonial sites; however, it does not apply to subsistence features, artisan gathering sites, and ethnobotanical gathering sites.

Within 1 year of the effective date of EO 13007, the head of each agency was directed to report the following to the President:

- Changes necessary to accommodate access to Indian sacred sites.
- Changes necessary to avoid adversely affecting the physical integrity of sacred sites.
- Procedures implemented or proposed to facilitate consultation with appropriate Indian tribes and religious leaders and resolution of disputes.

A draft report for compliance with EO 13007, prepared by DOE in May 1997, states that DOE will accommodate access to sites by working directly with tribes to identify their needs for access or barriers to access, developing MOAs with tribes, and developing and implementing cultural resource plans in consultation with tribal officials. Changes necessary to avoid adversely affecting Indian sacred sites are continuing outreach to tribes to expand DOE’s ability to identify sites, to develop and to implement cultural resource plans in

consultation with tribes, and to incorporate tribal representatives into cultural resource planning. Consultation with Indian tribes will be facilitated by training DOE personnel, with assistance from tribal members; developing specific consultation procedures or using existing procedures such as those for the *National Environmental Policy Act* (NEPA) (42 U.S.C. §4321) and Section 106 compliance, and seeking to resolve disputes with tribes.

Other legislation explicitly requires inventories of significant resources. Section 110 of the NHPA requires agencies to inventory significant sites under their jurisdiction and to develop plans to manage those resources. Also, EO 11593, §2(a) (1971) orders agencies to “locate, inventory, and nominate to the Secretary of the Interior all sites, buildings, and objects under their jurisdiction or control that appear to qualify for listing in the NRHP.” Furthermore, it directs agencies to submit to the Secretary of the Interior procedures for the maintenance and preservation of historic and archaeological sites under their control (EO 11593, §2[d]). This legislation forms the basis for protecting cultural resources.

E.5 RESEARCH METHODOLOGY

Anthropologists and historians have developed the concept of historical context as a framework to facilitate the evaluation of significance. Historical context facilitates the evaluation process by grouping information about cultural resources based on a shared theme, specific time period, and geographical area (48 *Federal Register* [FR] 44739). Historical context provides a flexible and legitimate basis for site-wide planning decisions that may affect cultural resources, and is developed by the SHPO to provide a basis for evaluating prehistoric and historic sites by identifying patterns or research problems in the historical and prehistoric record. Patterns or research problems include (48 FR 44718–44719):

- The chronological period and geographical area of each context.
- A compilation of existing information obtained through literature and background searches.
- The identification of trends in research and cultural values of the settlement, architecture, and art.
- A definition of property or site types by characteristics of each type.
- The identification of gaps in the body of information concerning historical context.

Historical context, then, includes both temporal and spatial information as well as artifacts and structures. It is ideal for incorporating cultural resources into the SWEIS because it is nonjudgmental; it includes elements of significance without implicating sites or localities as significant or insignificant. While the development of context is beyond the scope of the SWEIS, the SWEIS research methodology used the paradigm outlined above to categorize cultural resources.

Historical contexts are not well defined for New Mexico. Researchers in the state generally apply a research design published in 1981 by the State of New Mexico, Office of Cultural Affairs, Historic Preservation Division, titled “Prehistoric New Mexico; Background for Survey” (Stuart and Gauthier 1981). Although this research is applicable, it lacks the framework to evaluate site significance that is intended for contexts. Several Historic Period contexts were defined in a manuscript titled “New Mexico Historic Contexts” (Pratt and Scurlock 1993). Pratt and Scurlock (1993) recommended the development of a nuclear energy context, extending in time from 1943 to the present and including Los Alamos, Albuquerque, the Trinity Site, and southeastern New Mexico, with associated property types (laboratories, reactors, nuclear development and testing sites, and waste storage sites). The absence of a defined nuclear energy context makes classification and evaluation of historic

resources at LANL difficult and results in a data gap for the SWEIS and for the cultural resources management program at LANL.

E.5.1 Research Methods for Acquiring Data on Prehistoric Cultural Resources

Archaeological and cultural data on the existing prehistoric cultural resources at LANL were acquired from the LANL Cultural Resources Management Team; the New Mexico Office of Cultural Affairs, Historic Preservation Division; the New Mexico State Register of Cultural Properties; and the Museum of New Mexico, Laboratory of Anthropology, Archaeological Records Management Systems (ARMS). A review of published records and literature about the history and cultures of northern New Mexico was also conducted as part of the SWEIS.

Comprehensive data on cultural resources at LANL are maintained in paper and electronic databases and Geographic Information System (GIS) by the LANL Cultural Resource Management Team and include both compliance information and cultural/archaeological data (PC 1995). The LANL Cultural Resources electronic database was reviewed. Some sites have been recorded or confirmed recently by the LANL Cultural Resource Management Team, while others have been previously recorded, using methods and controls that may be different from present standards. Sites are classified in the electronic database according to available information on location, site type, and eligibility status. They are not, however, classified according to age or cultural affiliation. Cultural resource data are transferred, using site forms, from LANL to the New Mexico ARMS database at the Museum of New Mexico, Laboratory of Anthropology. A lag of approximately 10 years exists in the processing and transfer of some data to ARMS, resulting in differences in the numbers of sites in

each electronic database as well as in the types of information conveyed in each database.

Attempts were made to reconcile the two electronic databases in order to obtain information about the historical context of prehistoric resources and the numbers and types of cultural components of each site. Discrepancies were found between the two electronic databases that prevented the inclusion of ARMS data in the SWEIS. Therefore, the site numbers, locations, and site type data provided by the LANL Cultural Resources Team form the basis of this study. Prehistoric resources were incorporated into a GIS for overlay impacts analysis. Methods were developed to ensure that sensitive cultural resource information was not jeopardized during the study.

E.5.2 Research Methods for Acquiring Data on Historic Cultural Resources

Data on Historic Period resources were obtained from several sources. Data relating to the Spanish Colonial and U.S. Territorial periods were obtained from the LANL Cultural Resource Management Team database and publications. Data about cultural resources constructed at LANL during the Nuclear Energy Period were obtained from the LANL report, *Capital Asset Management Process, Fiscal Year 1997* (LANL 1995a), the Facility for Information Management, Analysis, and Display (FIMAD) database (LANL 1996), the as-built structure location maps for LANL (GITL 1997), the Environmental Restoration Program Decommissioning Summary Site Plan (LANL 1995b), and the LANL Cultural Resource Management Team database and publications. The locations of known structures dating from the Nuclear Energy Period were determined from facility maps and incorporated into a GIS for overlay impacts analysis.

These data do not include non-building remains of those periods and do not fully identify the numerous interrelated infrastructure support systems and functional systems present at LANL. The LANL Cultural Resource Management Team has a database of potential historic facilities that includes many existing and demolished structures (LANL Cultural Resource Database). These data have been excluded from the list of known resources until further documentation can be obtained to link them with the historical context of the Nuclear Energy Period.

E.5.3 Research Methods for Acquiring Data on Traditional Cultural Properties

TCPs were studied, using methods designed to identify categories and specific resources, to assess potential impacts from LANL operations and to provide recommendations to protect those resources from adverse effects from future LANL activities. The purpose of the study was to determine if properties exist within the LANL region that continue to hold cultural significance to those groups claiming traditional use or affiliation with the LANL area. TCP identification, evaluation, and documentation processes were conducted using the guidelines specified in *National Register Bulletin 38* (Parker and King 1990), which addresses eligibility to the NRHP. Natural, physical, biological, political, ideological, and man-made places significant to the local communities for ideological, economic, or historic reasons were identified in this study.

The goals of the SWEIS TCP study were to identify:

- Those American Indian, Hispanic, and other communities with cultural affiliations in the LANL area.

- The types of TCPs in the LANL region that could be affected by LANL and the kinds of LANL activities that could affect them.
- Potential avenues of mitigation that would avoid or minimize impacts to traditional properties.

The primary focus of the TCP study was American Indian and Hispanic traditional communities. However, if TCPs associated with other cultures or groups were identified during the course of this study, they were also acknowledged here.

The TCP research methods used in this study include the following elements:

- *Identify Traditional Communities That Maintain Affiliation with or Traditional Use of the LANL Area.* A 50-mile (80-kilometer) radius around LANL was used to identify communities to establish consultations. Other communities identified through the literature review were then added to the list.
- *Conduct Initial Consultations with Potential TCP Communities.* This level of consultation includes identifying appropriate contacts, making telephone calls, and setting up meetings with communities to introduce the SWEIS and inquire about their desire to participate in the SWEIS process.
- *Enter into Agreements for TCP Community Consultations.* Interested traditional communities established the methods for identifying TCPs of concern to them in the LANL area. Most traditional communities completed TCP field survey forms and provided either written or oral commentary on the cultural resource reference materials used in preparing sections of the Draft SWEIS. Participating traditional communities had review and editing rights regarding sensitive information prior to publication.
- *Review Ethnographic Literature.* Ethnographic literature was reviewed to understand the range and types of TCPs for selected traditional communities that have documented affiliations to the study area or have expressed a cultural affiliation to the affected environment on the basis of TCP community histories. The list of American Indian cultures covered in the ethnographic literature review includes approximately 17 Pueblo and Athabaskan cultures that have vested interests in the protection of traditional places in the LANL region. These cultures include the following:
 - Pueblo of Nambe
 - Hispanic Communities
 - Pueblo of Taos
 - Pueblo de Cochiti
 - Pueblo of Picuris
 - Pueblo of Jemez
 - Pueblo of San Ildefonso
 - Pueblo of Sandia
 - Jicarilla Apache Tribe
 - Pueblo of Santo Domingo
 - Pueblo of San Juan
 - Pueblo of Zia
 - Pueblo of Santa Clara
 - Pueblo of Zuni
 - Pueblo of Pojoaque
 - Hopi Tribe
 - Pueblo of Tesuque
 - Navajo Nation
- *Conduct the Consultations with Communities or Groups Identified.* Consultations are meetings held within the potentially affected community. They include community/tribal representatives, leaders, elders, and resource specialists identified during the research and networking efforts outlined above. A field survey form was designed to facilitate discussions with traditional communities, assist in the recording and classification of TCPs, record concerns of potential effects of LANL operations, record suggestions for

mitigation measures, and suggest methods to preserve TCPs. The methods used at TCP consultations were flexible in order to respond to the needs of different communities. For example, some communities conducted their own consultations. A Consultation Recording Sheet and a map showing LANL and surrounding areas were left with the communities. The consultations were completed by community members or staff and returned to the researchers.

- *Identify and Contact Traditional Hispanic Community Leaders.* Similar to Pueblo/Tribal consultations, consultations with Hispanic weavers, herbalists, lay-brotherhood members, artisans, acequia (shared community ditch) commissioners, mayordomos/mayordomas, and acequia federation offices were conducted to obtain information for the TCP study, solicit participation, and make possible the assessment of impacts. Consultations were conducted by letter, follow-up phone calls, group consultations, and site visits.
- *Identify and Invite the Participation of Regional Traditional Hispanic Organizations.* Hispanic organizations that represent the interests of traditional communities, such as artisan guilds, rural development organizations, and others were contacted and invited to participate in group consultations to identify Hispanic TCPs and possible impacts of LANL activities.
- *Conduct Hispanic Community Meetings and Interviews.* Hispanic TCPs were identified through two community meetings: one held in Jemez Springs, New Mexico, and the other held in Española, New Mexico. The general format of the meetings included a presentation on the goals and purpose of the SWEIS and definitions and examples of TCPs, followed by responses to questions regarding the TCP field survey forms. Records of the meetings were transcribed and submitted to the communities for review and comment.
- *Analyze Findings in TCP Field Survey Forms.* A classification system was developed for TCPs, based on the results of the literature search and consultations. This system was organized by category, including shrines, plant gathering areas, clay procurement areas for pottery making, hunting areas, technology sites (tool-making), and acequias. The analysis included synthesizing information from the literature review and consultations.
- *Review of TCP Information for the Draft SWEIS.* Consultations included a 30-day period to review the reference materials used for preparation of cultural resource sections of the Draft SWEIS. This was a separate review process that was limited strictly to the cultural resource sections. Upon receipt of review comments, the draft cultural resource sections were edited to reflect relevant comments.

E.5.4 Impacts Analysis Methods

The goals of the SWEIS cultural resources impacts analysis were to assess the general scale and intensity of impacts to the cultural resources from activity levels in each of the SWEIS alternatives. The cultural resource impacts analysis is not intended to take the place of project-specific NHPA and NEPA reviews, but to provide a comparative assessment of the impacts to cultural resources to be expected from each alternative.

The following parameters were established for impacts analysis:

- All cultural resources were considered in the cultural resource impacts analysis regardless of eligibility. These resources were from three broad categories: prehistoric archaeological sites, historic resources, and TCPs.
- The impacts analysis considers general categories of cultural resource types (e.g., simple and complex pueblos, scientific

laboratories, ceremonial sites) rather than impacts to individual resources. The types of effects and levels of adversity were determined for each resource class.

- Impacts are evaluated in a general manner and according to four broad categories that reflect the criteria of effect (36 CFR 800.9): destruction/alteration; isolation and restriction of access; introduction of visual, audible, or atmospheric elements out of character with the resource; and neglect leading to deterioration and vandalism. Not all classes of cultural resources will be affected by every category of effect.
- Adverse effects to any resource category were evaluated for each of the four SWEIS alternatives by means of a data matrix. Geographic overlay analysis and detailed project descriptions were used to assist in identifying the numbers and types of cultural resources that might be affected by the alternatives. Results of the consequence analysis for air quality, surface and groundwater, human health risk, and noise and vibration will be used to evaluate impacts to human users of TCPs and other potential impacts to cultural resources.
- Data from recent LANL operations were used as points of comparison for the relative severity of cultural resource impacts under each alternative. The degree of adverse impacts were qualitatively assessed according to the approximate number of resources adversely affected, the intensity of the impact, and the duration of the impact.

Table E.5.4–1 summarizes the potential for effects of various actions on categories of prehistoric cultural resources found at LANL. Table E.5.4–2 provides the potential for effects of various actions on historic resources at LANL, while Table E.5.4–3 gives the potential for effects of various actions on TCPs. LANL operations and projects reflected in the SWEIS alternatives were evaluated according to their

potential effects on nearby resources, as described in these tables.

E.6 EXISTING CONDITIONS FOR CULTURAL RESOURCES AT LANL

The following subsections contain discussions of LANL's cultural resource management and the existing prehistoric, historic, and traditional cultural resources within the boundaries defined in the SWEIS or within the areas of potential impact. All data on existing conditions within LANL boundaries, including policy, procedural issues, and existing resources, were obtained for 1995 conditions. It is assumed that both policies and known resources are constantly changing within a facility as large as LANL. One area of cultural resource management, in particular, has been undergoing rapid change at LANL: the development of new contacts among LANL and the various American Indian tribal governments.

E.6.1 Cultural Resource Management at LANL

Issues regarding cultural resources at LANL are handled by the LANL Cultural Resources Management Team (CRMT) of the Environmental Assessments and Resource Evaluations Group of the Environment, Safety, and Health Division at LANL.

In a memorandum from the Director of the Environmental Guidance Division, DOE Headquarters, dated February 23, 1990, DOE was directed to ensure that management of cultural resources at all DOE facilities is in compliance with all cultural resource executive orders, laws, and regulations. The memo further stipulates that DOE programs must budget sufficient funds to support cultural resource compliance actions and programs. The CRMT follows the LANL compliance procedure outlined in the LANL *Cultural Resource*

TABLE E.5.4-1.—Potential Impacts of Actions on Prehistoric Resource Types

ACTION TYPE	PUEBLO STRUCTURES	ERODED PUEBLOS/RUBBLE/ARTIFACT SCATTER	CAVATE PUEBLOS/ROCK ART/SHELTERS AND OVERHANGS	TRAILS/STEPS/ROCK RINGS OR STONE ARRANGEMENTS
New Construction (direct)	Destruction/alteration Removal of or damage to sites	Destruction/alteration Removal of or damage to sites	Destruction/alteration Removal of or damage to sites	Destruction/alteration Removal of or damage to sites
Increased Vibrations (from traffic, explosive testing, etc.)	Destruction/alteration Damage to sites	None	Destruction/alteration Removal of or damage to sites	Destruction/alteration Removal of or damage to sites
Increased Erosion or Siltation	Destruction/alteration Damage to sites	Destruction/alteration Damage to sites	Destruction/alteration Damage to sites	Destruction/alteration Damage to sites
Shrapnel Scatter from Firing Points	Isolation/restriction of access Inability to access sites because of hazardous conditions	Isolation/restriction of access Inability to access sites because of hazardous conditions	Isolation/restriction of access Inability to access sites because of hazardous conditions	Isolation/restriction of access Inability to access sites because of hazardous conditions
Explosives (direct hits)	Destruction/alteration Removal of or damage to sites	Destruction/alteration Removal of or damage to sites	Destruction/alteration Removal of or damage to sites	Destruction/alteration Removal of or damage to sites
Radiation Hazards (from airborne or waterborne contamination)	Isolation/restriction of access Inability to access sites because of hazardous conditions	Isolation/restriction of access Inability to access sites because of hazardous conditions	Isolation/restriction of access Inability to access sites because of hazardous conditions	Isolation/restriction of access Inability to access sites because of hazardous conditions
Noise	None	None	None	None
Hazardous Material (nonradiological from airborne or waterborne contamination)	Isolation/restriction of access Inability to access sites because of hazardous conditions	Isolation/restriction of access Inability to access sites because of hazardous conditions	Isolation/restriction of access Inability to access sites because of hazardous conditions	Isolation/restriction of access Inability to access sites because of hazardous conditions
Reduced Security	Destruction/neglect, alteration Removal of or damage to sites Deterioration and damage to sites from vandalism	Destruction/neglect, alteration Removal of or damage to sites Deterioration and damage to sites from vandalism	Destruction/neglect, alteration Removal of or damage to sites Deterioration and damage to sites from vandalism	Destruction/neglect, alteration Removal of or damage to sites Deterioration and damage to sites from vandalism

Note: For archaeological sites that are also TCPs, refer to Table E.5.4-3.

TABLE E.5.4-2.—Potential Impacts of Actions on Historic Resource Categories

ACTION TYPE	U.S. TERRITORIAL AND HOMESTEAD SITES	NUCLEAR ENERGY PERIOD BUILDINGS, DISTRICTS AND SITES (1943 TO 1989)			
		ADMINISTRATION BUILDINGS	STORAGE AND SERVICE	LABORATORIES AND PRODUCTION	HOUSING AND OTHER
New Construction (direct or indirect)	Destruction/alteration	Destruction/alteration	Destruction/alteration	Destruction/alteration	Destruction/alteration
	Removal of or damage to sites	Removal of or damage to sites	Removal of or damage to sites	Removal of or damage to sites	Removal of or damage to sites
	Introduction of elements out of character with setting	Introduction of elements out of character with setting	Introduction of elements out of character with setting	Introduction of elements out of character with setting	Introduction of elements out of character with setting
Increased Noise and Vibrations	Destruction/alteration	Destruction/alteration	Destruction/alteration	Destruction/alteration	Destruction/alteration
	Damage to sites	Damage to sites	Damage to sites	Damage to sites	Damage to sites
Increased Erosion or Siltation	Destruction/alteration	Destruction/alteration	Destruction/alteration	Destruction/alteration	Destruction/alteration
	Damage to sites	Damage to sites	Damage to sites	Damage to sites	Damage to sites
Explosives Testing (direct hits or shrapnel scatter)	Destruction/alteration	Destruction/alteration	Destruction/alteration	Destruction/alteration	Destruction/alteration
	Removal of or damage to sites	Removal of or damage to sites	Removal of or damage to sites	Removal of or damage to sites	Removal of or damage to sites
Radiation and Nonradiological Hazards (from airborne or waterborne contamination)	Isolation Inability to access sites because of hazardous conditions	Isolation Inability to access sites because of hazardous conditions	Isolation Inability to access sites because of hazardous conditions	Isolation Inability to access sites because of hazardous conditions	Isolation Inability to access sites because of hazardous conditions
Decommissioning and Demolition	Destruction/alteration	Destruction/alteration	Destruction/alteration	Destruction/alteration	Destruction/alteration
	Removal of or damage to sites	Removal of or damage to sites	Removal of or damage to sites	Removal of or damage to sites	Removal of or damage to sites
Refurbishing Buildings; Changing Building Function	None	Destruction/alteration	Destruction/alteration	Destruction/alteration	Destruction/alteration
		Removal of or damage to significant components	Removal of or damage to significant components	Removal of or damage to significant components	Removal of or damage to significant components
		Introduction of elements out of character with setting	Introduction of elements out of character with setting	Introduction of elements out of character with setting	Introduction of elements out of character with setting

TABLE E.5.4-2.—Potential Impacts of Actions on Historic Resource Categories-Continued

ACTION TYPE	U.S. TERRITORIAL AND HOMESTEAD SITES	NUCLEAR ENERGY PERIOD BUILDINGS, DISTRICTS AND SITES (1943 TO 1989)			
		ADMINISTRATION BUILDINGS	STORAGE AND SERVICE	LABORATORIES AND PRODUCTION	HOUSING AND OTHER
Reduced Security/ Abandonment/Lack of Use	Neglect	Neglect	Neglect	Neglect	Neglect
	Deterioration and damage to sites from vandalism	Deterioration and damage to sites from vandalism	Deterioration and damage to sites from vandalism	Deterioration and damage to sites from vandalism	Deterioration and damage to sites from vandalism
	Destruction/alteration	Destruction/alteration	Destruction/alteration	Destruction/alteration	Destruction/alteration
	Removal of or damage to sites	Removal of or damage to sites	Removal of or damage to sites	Removal of or damage to sites	Removal of or damage to sites

**TABLE E.5.4-3.—Potential Impacts of Actions on
Traditional Cultural Property Categories**

ACTION TYPE	CEREMONIAL AND ARCH. SITES	NATURAL FEATURES	ETHNOBOTANICAL GATHERING SITES	ARTISAN MATERIALS GATHERING SITES	SUBSISTENCE FEATURES
New Construction (direct)	Destruction/alteration Removal of or damage to sites	Destruction/alteration Removal of or damage	Destruction/alteration Removal of or damage to sites	Destruction/alteration Removal of or damage to sites	Destruction/alteration Removal or damage to sites
New Construction (roads, towers, fences, signs or buildings that would be visible from TCPs or make TCPs more visible)	Introduction of elements out of character with setting Isolation Sites separated from trails and/or linked sites	Introduction of elements out of character with setting Isolation View interference	Introduction of elements out of character with setting Isolation Sites separated from trails and/or linked sites	Introduction of elements out of character with setting Isolation Sites separated from trails and/or linked sites	Destruction/alteration Disturbance of wildlife Isolation Sites separated from trails and/or linked sites
Increased Vibrations (from traffic, explosive testing, etc.)	Destruction/alteration Damage to sites	Destruction/alteration Damage to sites	Destruction/alteration Damage to sites Introduction of elements out of character with setting	Destruction/alteration Damage to sites Introduction of elements out of character with setting	Destruction/alteration Disturbance of wildlife
Increased Erosion or Siltation (from changes in runoff)	Destruction/alteration Damage to sites	Destruction/alteration Damage to sites	Destruction/alteration Damage to sites	Destruction/alteration Damage to sites	Destruction/alteration Damage to sites
Shrapnel from Firing Points	Destruction/alteration Removal of or damage to sites Introduction of elements out of character with setting Inability to access sites because of hazardous conditions	Destruction/alteration Removal of or damage to sites Introduction of elements out of character with setting Inability to access sites because of hazardous conditions	Destruction/alteration Damage to sites Isolation/restriction of access Inability to access sites because of hazardous conditions	Destruction/alteration Damage to sites Isolation/restriction of access Inability to access sites because of hazardous conditions	Destruction/alteration Disturbance of wildlife Isolation Inability to access sites because of hazardous conditions

**TABLE E.5.4-3.—Potential Impacts of Actions on
Traditional Cultural Property Categories-Continued**

ACTION TYPE	CEREMONIAL AND ARCH. SITES	NATURAL FEATURES	ETHNOBOTANICAL GATHERING SITES	ARTISAN MATERIALS GATHERING SITES	SUBSISTENCE FEATURES
Explosives (direct hits from testing)	Destruction/ alteration Removal of or damage to sites Introduction of physical changes in setting Isolation/ restriction of access Inability to access sites because of hazardous conditions	Destruction/ alteration Removal of or damage to sites Introduction of physical changes in setting Isolation/ restriction of access Inability to access sites because of hazardous conditions	Destruction/ alteration Removal of or damage to sites Isolation/restriction of access Inability to access sites because of hazardous conditions	Destruction/ alteration Removal of or damage to sites Isolation/ restriction of access Inability to access sites because of hazardous conditions	Destruction/ alteration Disturbance to wildlife Isolation/ restriction of access Inability to access sites because of hazardous conditions
Radiation Hazards (from airborne or waterborne contamination)	Introduction of elements out of character with setting Isolation/ restriction of access Inability to access sites because of hazardous conditions	Introduction of elements out of character with setting Isolation/ restriction of access Inability to access sites because of hazardous conditions	Isolation/restriction of access Inability to access sites because of hazardous conditions	Isolation/ restriction of access Inability to access sites because of hazardous conditions	Isolation/ restriction of access Inability to access sites because of hazardous conditions
Noise	Introduction of elements out of character with setting	Introduction of elements out of character with setting	Introduction of elements out of character with setting	Introduction of elements out of character with setting	Destruction/ alteration Disturbance to wildlife
Hazardous Material (Nonradiological from airborne or waterborne contamination)	Introduction of elements out of character with setting Isolation/ restriction of access Inability to access sites because of contamination	Introduction of elements out of character with setting Isolation/ restriction of access Inability to access sites because of contamination	Destruction/alteration Removal or damage to sites Isolation/restriction of access Inability to access sites because of contamination	Destruction/ alteration Removal or damage to sites Isolation/ restriction of access Inability to access sites because of contamination	Destruction/ alteration Removal or damage to sites Isolation/ restriction of access Inability to access sites because of contamination

**TABLE E.5.4-3.—Potential Impacts of Actions on
Traditional Cultural Property Categories-Continued**

ACTION TYPE	CEREMONIAL AND ARCH. SITES	NATURAL FEATURES	ETHNOBOTANICAL GATHERING SITES	ARTISAN MATERIALS GATHERING SITES	SUBSISTENCE FEATURES
Increased Security Restrictions	Isolation/ restriction of access Inability to access sites	Isolation/ restriction of access Inability to access sites	Isolation/restriction of access Inability to access sites	Isolation/ restriction of access Inability to access sites	Isolation/ restriction of access Inability to access sites
Changed Water Quality in Natural Springs/Streams	Destruction/ alteration Removal of or damage to sites Introduction of elements out of character with setting Isolation/ restriction of access Inability to access sites	Destruction/ alteration Removal of or damage to sites Introduction of elements out of character with setting Isolation/ restriction of access Inability to access sites	Destruction/alteration Removal of or damage to sites Introduction of elements out of character with setting Isolation/restriction of access Inability to access sites	Destruction/ alteration Removal of or damage to sites Introduction of elements out of character with setting Isolation/ restriction of access Inability to access sites	Destruction/ alteration Removal of or damage to sites Introduction of elements out of character with setting Isolation/ restriction of access Inability to access sites
Hydrologic Changes	Destruction/ alteration Removal of or damage to sites	Destruction/ alteration Removal of or damage to sites	Destruction/ alteration Removal of or damage to sites	Destruction/ alteration Removal of or damage to sites	Destruction/ alteration Removal of or damage to sites
Changes in Maintenance	Destruction/ alteration Erosion of archeological sites	Destruction/ alteration Erosion of natural features	Destruction/alteration Erosion of natural features	Destruction/ alteration Erosion of natural features	Destruction/ alteration Erosion of natural features
Reduced Security	Destruction/ alteration Removal of or damage to sites from vandalism	Destruction/ alteration Vandalism and damage from lack of protection	Destruction/ alteration Increased visitation and damage from lack of protection	Destruction/ alteration Increased use and damage from lack of protection	Destruction/ alteration Loss of wildlife from increased hunting or visitation
Transfer of Ownership (to ownership outside SHPO review)	Destruction/ alteration Removal of or damage to sites Neglect Damage from vandalism, loss of protected status	Destruction/ alteration Removal of or damage to sites Neglect Damage from vandalism, loss of protected status	Destruction/ alteration Removal of or damage to sites Neglect Damage from vandalism, loss of protected status	Destruction/ alteration Removal of or damage to sites Neglect Damage from vandalism, loss of protected status	Destruction/ alteration Removal of or damage to sites Neglect Damage from vandalism, loss of protected status

TABLE E.5.4-3.—Potential Impacts of Actions on Traditional Cultural Property Categories-Continued

ACTION TYPE	CEREMONIAL AND ARCH. SITES	NATURAL FEATURES	ETHNOBOTANICAL GATHERING SITES	ARTISAN MATERIALS GATHERING SITES	SUBSISTENCE FEATURES
New Fencing	Isolation/restriction of access Inability to access sites Introduction of elements out of character with setting	Isolation/restriction of access Inability to access sites Introduction of elements out of character with setting	Isolation/restriction of access Inability to access sites Introduction of elements out of character with setting	Isolation/restriction of access Inability to access sites Introduction of elements out of character with setting	Isolation/restriction of access Inability to access sites Introduction of elements out of character with setting

Overview and Data Inventory 1995. The procedure was designed to keep LANL in compliance with the NHPA of 1966, as amended (16 U.S.C. §470); the *Archaeological Resource Protection Act* (ARPA) of 1979; AIRFA of 1978 (42 U.S.C. §1996); Executive Order 13007, Section 2(b); NAGPRA of 1990 (25 U.S.C. §3001); NEPA (42 U.S.C. §4321); and DOE's American Indian Policy (DOE Order 1230.2).

According to the LANL compliance procedure, the CRMT follows a step-by-step process to evaluate LANL actions for cultural resource compliance.

- The CRMT reviews all proposed LANL actions to determine if they are undertakings as defined in 36 CFR Part 800. According to the LANL compliance procedure, "Undertakings are activities that have the potential to affect a cultural resource and are typically activities outside buildings that disturb the ground" (LANL 1995c).
- Once an action is determined to be an undertaking, the CRMT conducts surveys of the affected area to determine if eligible cultural resources are likely to be affected by the proposed action. Cultural resource surveys are LANL controlled-release documents that are sent to the SHPO for concurrence with findings and for making determinations of eligibility. The surveys are also sent to the governors of the four Accord tribes (San Ildefonso, Santa Clara, Jemez, and Cochiti) for comment and identification of TCPs in the affected area.
- If both the DOE and the SHPO agree that a particular undertaking will have an adverse affect on eligible cultural resources, the CRMT develops a mitigation plan, specifying how the adverse effect will be mitigated. The mitigation plan is reviewed and approved by the SHPO and the National Advisory Council on Historic Preservation. According to the LANL compliance procedure, input from the public and interested American Indian groups is also solicited.
- Implementation of the mitigation plan may involve excavation of prehistoric sites if they are eligible for the NRHP under Criterion D alone. Data are analyzed by the CRMT as specified by the mitigation plan, and all recovered artifacts are curated at the Museum of New Mexico in Santa Fe, New Mexico.

In addition to the steps outlined above, measures are taken by the CRMT to provide American Indian tribes with access to information and input to the process of cultural resource management. Monthly meetings are held among DOE, the CRMT, LANL's legal counsel, LANL's Government Relations Office, and representatives of the four Accord tribes: San Ildefonso, Santa Clara, Jemez, and Cochiti. At these meetings, tribal representatives are advised of projects that may have impacts to cultural resources. According to the LANL compliance procedure, "...their input is invited on all phases of cultural resource survey, report preparation, determination of effects to cultural resources, and design of mitigation measures" (LANL 1995c). Any other tribes that identify themselves to LANL as having cultural affiliation with the region may also take part in these meetings or may be notified of LANL actions and included in consultations (Oakes 1997).

For purposes of compliance with NAGPRA, since 1995 the CRMT policy has been to contact local pueblo groups believed to be culturally affiliated with prehistoric sites at LANL, whenever human remains are uncovered. These pueblo groups would be asked for direction in the treatment and disposition of human remains.

The CRMT maintains a cultural resource administrative paper database and an electronic database and GIS of archaeological survey data. Administrative and compliance data are maintained on paper and electronically. These data include project review information,

cultural resource survey data, and data on any subsequent reports. Archaeological data files include location data, site type, age, cultural affiliation, survey information, TA numbers, eligibility information, and any associated report numbers. As of 1995, the electronic prehistoric database did not contain data on the age or cultural affiliation of archaeological resources at LANL; however, these data could be found in the CRMT's paper database.

A separate electronic database has been maintained for historic resources at LANL from the Nuclear Energy Period (post-1942). This database is organized by LANL facility number and includes information about building or structure type, location, construction date, and current status or use. Some data have been added in 1995 from surveys that were conducted prior to demolition of a number of structures from this period. Comprehensive surveys have not been conducted to identify Nuclear Energy Period resources, including those from the World War II/Early Nuclear Weapons Development Period at LANL.

An archaeological site number is assigned to each new archaeological site that is encountered at LANL and a site form is filled out for most, but not all sites (LANL 1995c). Data included on the site forms have changed over the years, producing inconsistencies in the database. Beginning in 1995, the state's standard site form (used in the New Mexico Cultural Resource Information System) has been used by the CRMT. Prior to 1978, data on the site type and the age of the site were not consistently included on site forms used at LANL (PC 1995 and LANL 1995c). Site forms should be submitted to the SHPO for inclusion in the state database and the New Mexico Historic Preservation Division's ARMS. Some submittals to the SHPO are several years behind (PC 1995).

As a result of differences in information recorded on site forms at LANL and delays in the submittal of site forms to the SHPO,

discrepancies exist between the state site records and LANL records.

E.6.2 Prehistoric Resources Within LANL Boundaries

A total of 1,302 prehistoric archaeological sites (sites with unique Laboratory of Anthropology numbers) have been identified within or very near LANL boundaries during archaeological investigations (LANL 1995c). The areas being considered in the SWEIS contain 1,295 sites, according to GIS overlay analysis. A breakdown of archaeological site types is provided in Table E.6.2-1. The site types have been grouped in this table according to the manner in which they respond to various impacts, such as vibration, erosion, corrosion, or explosions.

Eligibility assessments have been made on 1,192 prehistoric sites, with 770 sites found to be eligible for inclusion in the NRHP. There are 322 sites that are potentially eligible, and only 100 sites have been determined ineligible for nomination to the NRHP. The remaining 103

TABLE E.6.2-1.—Prehistoric Cultural Resource Sites Within LANL Boundaries

SITE TYPE	NUMBER OF SITES
Simple Pueblos	665
Complex Pueblos	62
Rock Shelters, Cavate (small caves) Pueblos	213
Rock Art	40
Water Control Features, Game Traps	56
Trails, Steps	20
Highly Eroded Pueblos, Rubble	29
Artifact Scatter, Stone Chips (lithic scatter), Rock Rings	210
TOTAL	1,295

Source: LANL 1995c

sites have not been assessed for eligibility, but are assumed to be potentially eligible by the LANL CRMT until further assessment is completed (PC 1995).

Archaeological survey work has been extensive at LANL. Several hundred small, project-related archaeological surveys have been conducted since the implementation of the NHPA at LANL in the early 1970's (LANL 1995c). Only 25 percent of LANL remains completely unsurveyed (LANL 1995c). Many LANL areas have been surveyed for archaeological resources at 100 percent coverage; others have been surveyed with only 60 percent coverage.

E.6.3 Historic Cultural Resources Within LANL Boundaries

A total of 2,319 cultural resources date from the Historic Period. There are 87 known cultural resources within LANL boundaries that date from the Early U.S. Territorial/Statehood Period, as shown in Table E.6.3-1. Most of these cultural resources have been recorded and their eligibility has been established in some cases. Of the 87 homestead resources, 22 are eligible for the NRHP. One site is also listed on the State Register of Cultural Properties. Three of these sites have been excavated (LANL 1995c).

Most cultural resources attributed to the Historic Period date from the Nuclear Energy Period, beginning with World War II and continuing through the end of the Cold War in 1989. However, no systematic survey has been conducted of the Historic Period cultural resources within LANL boundaries, nor have these resources been uniformly evaluated for eligibility for nomination to the NRHP.

Historic data about resources constructed at LANL during the World War II and the Cold War Periods have been obtained for purposes of the SWEIS from the LANL report, *Capital*

Asset Management Process, Fiscal Year 1997 (LANL 1995a). These data do not include non-building remains of those periods, and the numerous interrelated infrastructure support systems and functional systems present at LANL are not fully identified (LANL 1995c). The LANL Cultural Resources Database of potential historic facilities includes many existing and demolished structures.

A search of available data indicates that about 2,232 buildings, structures, or trailers that date from the Nuclear Energy Period existed at LANL in 1995. Analysis of the data shows that about 515 resources date from 1943 through 1956, and 1,717 date from 1957 through 1989. These numbers are approximate because nonbuilding resources have not been identified and demolition actions are ongoing.

E.6.4 Traditional Cultural Properties in the LANL Region

Within LANL's limited access boundaries, there are ancestral villages, shrines, petroglyphs, sacred springs, trails, and traditional use areas that could be identified by Pueblo and Athabascan communities as TCPs. The LANL CRMT has a program in place to manage on-site cultural resources for compliance with NAGPRA and AIRFA (LANL 1995c). The Pueblos of San Ildefonso and Santa Clara are considered to be most directly affiliated with archaeological sites at LANL (PC 1995 and Oakes 1997). When there is an undertaking, LANL arranges site visits by tribal representatives of the four Accord Pueblos to solicit their concerns and to comply with applicable requirements and agreements. However, this notification has been limited to Section 106 and NAGPRA compliance. Until recently, there has never been a systematic study of the TCPs at LANL that would identify other communities with potential concerns. Furthermore, TCPs that are natural features, resource gathering places, or hunting areas,

TABLE E.6.3-1.—*Historic Sites Identified by the SWEIS*

HISTORIC PERIOD	DATES	CHARACTERISTIC CULTURAL EVIDENCE	NUMBER OF KNOWN ARTIFACTS OR SITES	NATIONAL REGISTER OF HISTORIC PLACES ELIGIBILITY
Spanish Colonial	A.D. 1600 to 1849	<ul style="list-style-type: none"> • Wagons • Iron hardware • Horse equipment • Pueblo V artifacts 	0	
Early U.S. Territorial/ Statehood	A.D. 1850 to 1942	<ul style="list-style-type: none"> • European and Hispanic homesteads • Commercial ranching concerns/guest ranches: Pond cabin, Anchor Ranch, and the Los Alamos Ranch School 	87	<p>Twenty-two sites are eligible for the NRHP.</p> <p>One site is also listed on the State Register of Cultural Properties.^a</p>
Nuclear Energy	A.D. 1943 to present			
a. World War II/ Early Nuclear Weapon Development Period	A.D. 1943 through 1948	<ul style="list-style-type: none"> • Original Los Alamos townsite • World War II Manhattan Project facilities where the design and manufacture of the “Trinity Site: bomb; Hiroshima bomb, “Little Boy;” and Nagasaki bomb, “Fat Man” occurred • LANL sites where all U.S. Nuclear Weapons were made from 1946 to 1950 • Common artifacts consist of buildings, security fences and stations, barricades, roads, reinforced protective structures 	515 (1943 to 1956)	<p>Seventy-seven sites are eligible for the NRHP (1943–1956). One is also listed on the State Register of Cultural Properties.^a</p>
b. Early Cold War Period	A.D. 1949 through 1956	Pronounced expansion of facilities		
c. Late Cold War Period	A.D. 1957 through 1989	Continued expansion of facilities	1,717	These LANL buildings have not been assessed for NRHP eligibility.
Total Number of Sites			2,319	

Sources: LANL 1995–1996, LANL 1995b, LANL 1995c, McGehee 1995, and NMHPD 1995.

^a The Ashley Pond cabin is listed twice because its occupation and use spans two historic periods.

have neither been identified nor considered in the evaluation of effects from LANL undertakings.

According to the LANL compliance procedure, American Indian tribes may request permission for visits to sacred sites within LANL boundaries for ceremonies (Oakes 1997). However, the procedure takes time, and no instances were found to indicate that tribes access ceremonial or other traditional sites by this means.

American Indian TCPs, located on lands outside LANL boundaries, such as tribal lands, state lands, federally managed lands, and private lands, may be potentially affected by LANL activities. Other federal agencies with land holdings in the area that may have TCPs include:

- U.S. Forest Service, Santa Fe and Carson National Forests
- NPS, BNM
- DOI, Bureau of Land Management, Taos Resource Area

Consultations were held with 19 American Indian tribes and two Hispanic communities as part of the SWEIS TCP study. Several contacts were made with 23 American Indian tribes; however, four did not participate in the consultations. Of the contacted communities, only the Pueblo of Santa Ana did not wish to participate at this time. The Pueblo of San Felipe showed interest during repeated

telephone contacts and presentations; however, they did not elect to hold consultations during the SWEIS TCP study. All of the consulting groups indicated that they had at least some TCPs present on or near LANL, as summarized in Table E.6.4–1. These resources are present throughout LANL and adjacent lands, including the neighboring BNM, reservation lands, Santa Fe National Forest and U.S. Forest Service land.

The following subsections outline the results of consultations with American Indian and Hispanic communities. These subsections comprise statements made during the consultations, classified by the following categories: ceremonial and archaeological sites, natural features, ethnobotanical gathering sites, artisan material gathering sites, and subsistence features.

E.6.4.1 Ceremonial Sites

- *Pueblo of Acoma*—Pueblo of Acoma officials do not claim cultural affiliation to sites in the LANL area except in a general sense as Pueblo people. They do, however, have concerns about the treatment of human remains that may exist in the LANL area. In addition, all archaeological sites in the area are considered sacred to all Pueblo people.
- *Pueblo of Cochiti*—Tribal representatives stated that LANL is part of their ancestral domain.
- *Pueblo of Jemez*—Although LANL is on the periphery of the ancestral Jemez

TABLE E.6.4–1.—Traditional Cultural Properties Identified by Consulting Communities on or near LANL Property

	CEREMONIAL AND ARCHAEOLOGICAL SITES	NATURAL FEATURES	ETHNO-BOTANICAL SITES	ARTISAN MATERIAL SITES	SUBSISTENCE FEATURES
Number of Consultations Indicating the Presence of TCPs on or near LANL	15	14	10	7	8

domain, since the days of prehistory, the Jemez people have continued to make pilgrimages to sacred sites in the vicinity of Los Alamos. The Jemez people have shrines in the Los Alamos area, but not in the LANL compound.

- *Pueblo of Laguna*—Representatives from the Pueblo of Laguna indicated that the LANL area is part of Laguna’s traditional use area and BNM is an important area to the tribe.
- *Mescalero Apache Tribe*—Tribal representatives stated that at least three ceremonial feast areas are located in the LANL area.
- *Navajo Nation*—Navajo tribal records document that the LANL area is a very old traditional use area with at least 20 ceremonial/archaeological sites in the area.
- *Pueblo of Picuris*—Representatives from the Pueblo of Picuris stated that their people have cultural affiliation with archaeological sites near and at LANL.
- *Pueblo of Pojoaque*—A representative from the Pueblo of Pojoaque stated that the Pueblo has traditional sites in the LANL area. Tribal members mostly travel to the east to hold ceremonies but go in all directions for prayers; e.g., towards Santa Fe and White Rock. Many tribal members long ago went to the Los Alamos area, traveling through San Ildefonso and Garcia Canyon to White Rock. Oral stories often pertain to Jacona Peak and the BNM area. A traditional trail traverses what is now LANL, but it is no longer used due to denied access.
- *Pueblo of Sandia*—Tribal officials from the Pueblo of Sandia said that archaeological sites in the LANL area are important. Sandia is concerned over the treatment of human remains. “They should be left alone,” according to tribal representatives.
- *Pueblo of San Ildefonso*—The Pueblo of San Ildefonso recognizes the Los Alamos area as its ancestral domain. San Ildefonso claims to have over 1,500 TCPs within LANL boundaries.
- *Pueblo of Santo Domingo*—Officials from the Pueblo of Santo Domingo said tribal members use springs in the high country for ceremonial purposes, and they are concerned about pollution at these springs.
- *Pueblo of Taos*—Tribal representatives stated that tribal members travel to areas near LANL for ceremonial functions; and that, although they no longer conduct traditional activities in the immediate area of LANL, it is still considered to be sacred to them.
- *Pueblo of Zia*—Traditional routes to buffalo hunting areas in Colorado traverse LANL, along the Cuba Road and up the Rio Grande. Another route goes along the base of the Pajarito Plateau, east of LANL. These routes contain many shrines and many of these shrines are recounted in oral stories. There are also many archaeological sites, shrines, and springs in the LANL area that are important to the Zia people.
- *Pueblo of Zuni*—Representatives from the Pueblo of Zuni stated that they are concerned about the archaeological sites in the region; e.g, the Stone Lions at BNM. Prehistoric pottery affiliated with the Zuni people has been found at LANL.
- *Hispanic Communities*—Hispanic communities identified several ceremonial sites, such as traditional pilgrimage route that leads from the Jemez Springs area, through LANL, and along the highway to the Santuario de Chimayo. Another pilgrimage route exists between Wagon Mound and the Santuario de Chimayo. Pilgrimages are conducted on foot both at Christmas and during Lenten week. A third pilgrimage or procession area exists along Highway 84 near Abiquiu. Many pilgrimage trails converge on the Santuario de Chimayo in the Nambe area. Some representatives mentioned that privatization of some land had limited access to pilgrimage trails and sacred sites.

Descansos, crosses or stone markers along pilgrimage routes are used as sites to remember the dead. Ceremonies are also conducted along the acequias in some villages to protect the water and ensure good crops, according to Hispanic consultants.

E.6.4.2 Natural Features

- *Pueblo of Acoma*—Officials from the Pueblo of Acoma stated that the LANL area is sacred.
- *Hopi Tribe*—Hopi tribal representatives stated they hold the Jemez Mountains as traditionally significant, and Hopi Kachinas go to their home in these mountains.
- *Jicarilla Apache Tribe*—The Jemez Mountains were identified by the Jicarilla Apache Tribe as culturally significant. They have traditionally bathed in hot springs in various locations, including the Jemez area and Pagosa Springs.
- *Mescalero Apache Tribe*—The Mescalero Apache tribal officials indicated that Los Alamos Mountain is of traditional importance.
- *Navajo Nation*—Tribal documents of the Navajo Nation identify 19 natural features in the LANL area. The Jemez Mountains are significant and Pajarito Mountain and Pajarito Springs are considered sacred. Pajarito Mountain is tied to the Navajo creation story.
- *Pueblo of Picuris*—Tribal members of the Pueblo of Picuris have traditionally used the hot springs at Jemez.
- *Pueblo of Pojoaque*—Oral stories from the Pueblo of Pojoaque pertain to Jacoma Peak and BNM.
- *Pueblo of Sandia*—Springs in and around LANL are important to members of Sandia Pueblo. They consider all springs as shrines, sacred places for prayer.
- *Pueblo of San Juan*—Representatives from the Pueblo of San Juan stated that among

the significant resources in the LANL area, Jacoma Peak is one of the most important.

- *Pueblo of Santa Clara*—Tribal officials from the Pueblo of Santa Clara stated that the entire Pajarito Plateau is significant not only to Santa Clara but to all the Pueblos.
- *Zia Pueblo*—One of the important features to the Zia people is Santa Clara Peak.
- *Pueblo of Zuni*—Representatives from the Pueblo of Zuni said the LANL area is part of their traditional use area and tribal members collect water in the vicinity. They are concerned about the effects of LANL activities on springs.
- *Hispanic Communities*—Natural features were not mentioned as important Hispanic TCPs in any consultations.

E.6.4.3 Ethnobotanical Gathering Sites

- *Hopi Tribe*—Members of the Hopi Tribe gather cattails from the LANL area for dances.
- *Pueblo of Jemez*—The Jemez people have traditionally collected and continue to collect medicinal plants and other plants in the Los Alamos vicinity.
- *Jicarilla Apache Tribe*—Members of the Jicarilla Apache tribe collect willow, sumac, and medicinal plants in the LANL area.
- *Mescalero Apache Tribe*—Members of the Mescalero Apache tribe have plant gathering areas near LANL.
- *Pueblo of Nambe*—Officials from the Pueblo of Nambe stated that the Los Alamos area is a Nambe traditional use area and the people from the Pueblo gather plants in the vicinity.
- *Pueblo of Pojoaque*—Pojoaque tribal members go towards Santa Fe and White Rock for pinyon nut gathering and plant gathering.

- *The Pueblo of Sandia*—Tribal officials cannot give specific plant collection locations because weather patterns change and collection locations change annually with weather patterns. They collect wild tobacco, prickly pear, yucca root, gooseberries, chokecherries, osha, wild spinach, bee weed (for paint), wild garlic, and juniper roots from the Jemez Mountains and around Fenton Lake, as well as pinyon nuts and evergreens from the Jemez Mountains.
- *Pueblo of Zia*—Many herbs are collected by members of Zia Pueblo in the canyons around LANL, such as Pueblo Canyon.
- *Pueblo of Zuni*—Representatives of the Pueblo of Zuni said tribal members collect plants in the LANL vicinity.
- *Hispanic Communities*—Many wild plants are gathered for medicine and food by traditional Hispanic people in the LANL region. The Jemez Mountains were mentioned during the consultations as an important area for gathering pinyon nuts, wild fruit, and herbs. The areas where herbs are picked vary according to season and year. Some of the medicinal plants that are gathered in the LANL region include cota, osha, yerba buena, and chimaha. Participants mentioned that families and groups make outings to the mountains to gather plants. Barranca Mesa, north of LANL boundaries, and Ojo Caliente were identified as important areas to gather wild plants.
- *Clara and Taos areas, and the Sangre de Cristo Mountains*. Micaceous clay is collected in numerous places including the El Rito area.
- *Pueblo of Nambe*—Members of the Pueblo of Nambe gather minerals in the vicinity.
- *Navajo Nation*—Navajo tribal records document four resource gathering areas in the LANL area.
- *Pueblo of Picuris*—Tribal members of the Pueblo of Picuris have collected chert near Cochiti, and their ancestors collected obsidian in the LANL area.
- *Pueblo of Taos*—Tribal members collect clay and wood from the Santa Clara and San Juan areas.
- *Pueblo of Zia*—Obsidian is collected at Obsidian Ridge by tribal members of Zia Pueblo.
- *Hispanic Communities*—Members of the Hispanic communities mentioned wood for vigas and latillas, wood for carving, and plants to dye wool, as materials commonly gathered from the areas around LANL. Some dye plants such as goldenrod are gathered along acequias. Other plants are gathered along roadsides (chamisa and cota) or in the foothills (Mormon tea). Wood for carving Santos is collected in the Los Alamos area, including cottonwood and aspen from the Santa Fe National Forest. Juniper is gathered in bulk by families for carving. Santa Clara, El Rito, the Tecolote area near La Madera, and Dixon were mentioned as areas where clay is gathered. Micaceous clay is gathered at Petaca. Special crystals called Lagrimas de Dios are collected near Dixon by artisans. One consultant mentioned that she had formerly gathered ephedra and other plants to dye her wool along the roads around LANL, but had discontinued the practice because she believed the plants were contaminated.

E.6.4.4 *Artisan Material Gathering Sites*

- *Pueblo of Jemez*—The Jemez people collect obsidian and other minerals from the area.
- *Jicarilla Apache Tribe*—Members of the Jicarilla Apache tribe collect clay, pigment, and plants for basketry in the LANL area, including the Jemez Mountains, the Santa

E.6.4.5 *Traditional Subsistence Features*

- *Pueblo of Jemez*—The Jemez people collect water from ancient springs in the area and hunt deer and elk that have migrated into the ancestral Jemez domain from the LANL area.
- *Jicarilla Apache Tribe*—Members of the Jicarilla Apache Tribe hunt in the LANL area, and some of their livestock graze near the southern border of the Jicarilla Apache reservation.
- *Pueblo of Nambe*—Officials from the Pueblo of Nambe stated that the Los Alamos area is a Nambe traditional use area and the Pueblo has TCPs located within the vicinity. Many traditional, ceremonial, and culturally used products are gathered within the area that they feel may be affected by current and future LANL undertakings. The Pueblo of Nambe people use the Los Alamos area for hunting, fishing, and wood gathering. In addition, tribal members farm, raise crops, provide feed for livestock, and gather plants and minerals in the vicinity.
- *Navajo Nation*—Tribal documents of the Navajo Nation identified two trade centers in the LANL area.
- *Pueblo of Pojoaque*—Many tribal members from the Pueblo of Pojoaque went to the Los Alamos area long ago, traveling through San Ildefonso and Garcia Canyon to White Rock, and many still hunt in this vicinity.
- *Pueblo of Sandia*—Members of the Pueblo of Sandia hunt deer and elk in the Jemez Mountains and north to the Colorado Border. They fish in the Santa Clara and Jemez areas, Santa Cruz Lake, and at Nambe Falls.
- *Pueblo of Taos*—Tribal members use the Rio Pueblo and the Rio Grande for collection of water.
- *Pueblo of Zia*—Activities that historically have taken place in Pueblo Canyon include animal collection using deer traps. Tribal members consider these deer traps to be traditional properties. The area around LANL was a prime hunting area.
- *Hispanic Communities*—Protection of the water rights and water quality of the acequias are very important to traditional Hispanic communities. Rituals are performed in the springtime to bless the water, along with the annual cleaning of the acequias. This was mentioned by several informants as very important to the community. One informant said that this was the way her children learned about the ways of the people, by working together to keep the ditch clean and to allocate the water.

Hunting and fishing were mentioned by Hispanic informants as being important traditional subsistence activities that bring together families. Outings into the mountains to hunt also include gathering pinyon nuts and fruit or firewood and involve several family members. Informants mentioned that their families used to hunt in the LANL area, but now are prevented by LANL fences and private land. People in Jemez Springs said that hunting and fishing is important to their local traditions. Wild meat is a staple of their diet in many families, and teaching one's children to provide their own meat and jerky was mentioned as an important tradition. A participant described hunting for deer in Guaje Canyon and wild turkey around Barranca Mesa many years ago, but he no longer has access to these areas.

REFERENCES

- ACHP 1991 *Balancing Historic Preservation Needs with the Operation of Highly Technical or Scientific Facilities*. Advisory Council on Historic Preservation. A report to the U.S. House of Representatives, Committee on Interior and Insular Affairs, Subcommittee on National Parks and Public Lands, and the Committee on Science, Space, and Technology. Washington, D.C. 1991
- Ackerly et al. 1993 *Acequia Systems of the Velarde Region: North-Central New Mexico, Volume 1: Overview*. N. W. Ackerly, W. Malonic, M. Ernst, J. Wakeman, and L. Lopez. A report prepared by the Center for Anthropological Research, New Mexico State University. Las Cruces, New Mexico. 1993.
- Ahlborn 1968 *The Penitente Moradas of Abiquiu*. Richard E. Ahlborn. Contributions from the Museum of History and Technology. Paper 63. Smithsonian Institution Press. Washington, D.C. 1968.
- Akins 1993 *Traditional Use Areas in New Mexico*. Nancy J. Akins. Timothy D. Maxwell, Principal Investigator, Museum of New Mexico, Office of Archaeological Studies, Office of Cultural Affairs, Historic Preservation Division. Archaeology Note 141. Santa Fe, New Mexico. 1993.
- Anonymous 1976 "Rio Grande Weaving and Dyeing Workshop." *National Endowment for the Arts and the New Mexico Arts Commission Handbook*. Santa Fe, New Mexico. 1976.
- Arrellano 1994 *The Acequia and Agricultural Tradition of New Mexico: Prehistoric Through the Present*. Anselmo Arrellano. Center for Land Grant Studies. Research Paper No. 22. Guadalupita, New Mexico. 1994.
- Bandelier 1892 "Final Report of Investigations Among the Indians of the Southwestern United States Carried on Mainly in the Years from 1880–1885." A. Bandelier. *Papers of the Archaeological Institute of America*, American Series IV, Part II. Peabody Museum of American Archaeology and Ethnology, Harvard University. Cambridge, Massachusetts. 1892.
- Benedict 1931 "Tales of the Cochiti Indians." Ruth Benedict. Smithsonian Institution, Bureau of American Ethnology Bulletin 98. Washington, D.C. 1931.
- Biella 1977 "Previous Anthropological Research in the Cochiti Study Area." Jan V. Biella. *Archeological Investigations in Cochiti Reservoir, New Mexico. Volume 1: A Survey of Regional Variability*. Jan V. Biella and Richard C. Chapman, eds. University of New Mexico, Office of Contract Archeology. pp. 105-150. Albuquerque, New Mexico. 1977.

- Biella and Chapman 1977–1979 *Archeological Investigations in Cochiti Reservoir, Volumes 1-4.* Jan V. Biella and Richard Chapman. University of New Mexico, Office of Contract Archaeology. Albuquerque, New Mexico. 1977–1979.
- Brayer 1938 *Pueblo Indian Land Grants of the 'Rio Abajo,' New Mexico.* Herbert O. Brayer. University of New Mexico Bulletin 334. University of New Mexico Press. Albuquerque, New Mexico. 1938.
- Briggs 1980 *The Wood Carvers of Cordova, New Mexico: Social Dimensions of an Artistic Revival.* Charles L. Briggs. University of New Mexico Press. Albuquerque, New Mexico. 1980.
- Broster 1983 “Paleo-Indian Adaptations to High Altitudes on Cebolleta Mesa.” John B. Broster. *High Altitude Adaptations in the Southwest.* Joseph C. Winter, ed. Cultural Resources Management Report No 2. U.S. Department of Agriculture, U.S. Forest Service. Albuquerque, New Mexico. 1983.
- Cajete 1994 *Look to the Mountain, An Ecology of Indigenous Education.* G. Cajete. Kivaki Press. Durango, Colorado. 1994.
- Campa 1979 *Hispanic Culture in the Southwest.* Arthur L. Campa. University of Oklahoma Press. Norman, Oklahoma. 1979.
- Carlson 1990 *The Spanish-American Homeland.* Alvar W. Carlson. Johns Hopkins University Press. Baltimore, Maryland. 1990.
- Caywood 1966 *Excavations at Rainbow House.* L. R. Caywood. Bandelier National Monument, U.S. Department of the Interior, National Park Service, Southwest Archaeological Center. Globe, Arizona. 1966.
- Cline 1972 “Spanish and Mexican Land Grants in New Mexico, 1689–1848.” H. F. Cline. Expert Testimony before the Indian Claims Commission. Clearwater Publishing. New York, New York. 1972.
- Cordell 1979 *Cultural Resources Overview: Middle Rio Grande Valley, New Mexico.* L. S. Cordell. U.S. Department of Agriculture, Forest Service, Southwestern Region. Albuquerque, New Mexico. 1979.
- Cordell 1984 *Prehistory of the Southwest.* L. S. Cordell. Academic Press. New York, New York. 1984.
- Curtin 1947 *Healing Herbs of the Upper Rio Grande.* L. S. M. Curtin. Laboratory of Anthropology. Santa Fe, New Mexico. 1947.
- DeHuff 1931 “Pojoaque Giant: An Indian Legend of the Black Mesa.” Elizabeth W. DeHuff. *New Mexico Magazine.* pp. 18-19. Santa Fe, New Mexico. December 1931.

- Dickey 1990 *New Mexico Village Arts*, 3rd edition. R. F. Dickey. University of New Mexico Press. Albuquerque, New Mexico. 1990.
- DOD 1993 *Coming in From the Cold: Military Heritage in the Cold War*. U.S. Department of Defense, U.S. Air Force History Office. Washington, D.C. 1993.
- DOE 1994 *American Indian Policy*. U.S. Department of Energy. Washington, D.C. 1994.
- DOE 1995 *Final Draft Cultural Resources Survey Report*. Rocky Flats Environmental Technology Site. Rocky Flats, Colorado. 1995.
- DOE et al. 1992 *Interagency Agreement for Mutual Cooperation and Respect*. U.S. Department of Energy, Pueblo of San Ildefonso, Pueblo de Cochiti, Pueblo of Santa Clara, and Pueblo of Jemez. Washington, D.C. 1992.
- Douglas 1917 “Notes on the Shrines of the Tewa and Other Pueblo Indians of New Mexico.” William Boone Douglas. *Proceedings of the Nineteenth Congress of Americanists*. pp. 334-378. Washington, D.C. 1917.
- Dunmire and Tierney 1995 *Wild Plants of the Pueblo Province: Exploring Ancient and Enduring Uses*. W. W. Dunmire and G. D. Tierney. Museum of New Mexico Press. Albuquerque, New Mexico. 1995.
- Ellis 1979 “The History of San Ildefonso and Its Irrigation System.” Florence Hawley Ellis. *Summaries of the History of Water Use and the Tewa Culture of the Pojoaque Valley Pueblos*. Unpublished manuscript on file, Laboratory of Anthropology. Santa Fe, New Mexico. 1979.
- Elmore 1944 *Ethnobotany of the Navajo*. Francis H. Elmore. School of American Research. Monographs: 8. Santa Fe, New Mexico. 1944.
- Evans et al. 1993 *Petroglyph National Monument Rapid Ethnographic Assessment Project*. Michael J. Evans, Richard W. Stoffle, and Sandra Lee Pinel. University of Arizona, Bureau of Applied Research in Anthropology. Tucson, Arizona. 1993.
- Ferguson and Hart 1985 *A Zuni Atlas*. University of Oklahoma Press. Norman, Oklahoma. 1985.
- Ford 1968 “An Ecological Analysis Involving the Population of San Juan Pueblo, New Mexico.” Richard Ford. Ph.D. dissertation. University of Michigan. Ann Arbor, Michigan. 1968.

- Ford 1976 "The Technology of Irrigation in a Northern New Mexico Pueblo." Richard Ford. *Material Culture: Styles, Organization, and Dynamics of Technology*. 1975 Proceedings of the American Ethnological Society. Robert F. Spencer, general ed. Heather Lechtman and Robert Merrill, eds. West Publishing. New York, New York. 1976.
- Friedlander and Pinyan 1980 *Indian Use of the Santa Fe National Forest: A Determination from Ethnographic Sources*. Eva Friedlander and Pamela J. Pinyan. Center for Anthropological Studies. Ethnohistorical Report Series No. 1. Albuquerque, New Mexico. 1980.
- GITL 1997 Maps and overlays prepared for the Los Alamos National Laboratory Site-Wide Environmental Impact Statement. Geographic Information Technologies Laboratory, Geographic Information System. 1997.
- Hale and Harris 1979 "Historical Linguistics and Archaeology." K. Hale and D. Harris. *Handbook of North American Indians*, Vol. 9, GPO, pp. 170-177. Alfonso Ortiz, ed. Smithsonian Institution. Washington, D.C. 1979.
- Hammond and Rey 1966 *The Rediscovery of New Mexico, 1580–1594*. George P. Hammond and Agapito Rey, eds. University of New Mexico Press. Albuquerque, New Mexico. 1966.
- Harrington 1916 "The Ethnogeography of the Tewa Indians." John Peabody Harrington. *Twenty-Ninth Annual Report of the Bureau of American Ethnology, 1907–1908*. GPO, Vol. 29, p. 636. Washington, D.C. 1916.
- Hart and Ferguson 1993 *Ethnohistorical Reports Relative to the Pueblos of Zuni, Hopi and Acoma and the Ramah Band of the Navajo Nation*. E. Richard Hart and T. J. Ferguson. Institute of the North American West. Seattle, Washington. 1993.
- Hendricks 1993 "Road to Rebellion, Road to Reconquest: The Camino Real and the Pueblo-Spanish War, 1680–1696." Rick Hendricks. *El Camino Real de Tierra Adentro*, Cultural Resources Series No. 11. Gabrielle Palmer, ed. New Mexico Bureau of Land Management. Albuquerque, New Mexico. 1993.
- Hendron 1946 *Frijoles, A Hidden Valley in the New World*. J. W. Hendron. Rydal Press. Santa Fe, New Mexico. 1946.
- Hewett 1904 "Archaeology of the Pajarito Park, New Mexico." Edgar L. Hewett. *American Anthropologist*. Vol. 6, No. 5, pp. 629-659. 1904.

- Hewett and Dutton 1945 "The Pueblo Indian World." Edgar L. Hewett and Bertha P. Dutton. *Handbooks of Archaeological History*. University of New Mexico and School of American Research. University of New Mexico Press. Albuquerque, New Mexico. 1945.
- Hiles 1992 "An Archaeologist Guide to Native American Use of Southwestern Plants." Harold T. Hiles. *Southwestern Research Native*. Fairacres, New Mexico. 1992.
- Hill 1982 *An Ethnology of Santa Clara Pueblo, New Mexico*. W. W. Hill. University of New Mexico Press. Albuquerque, New Mexico. 1982.
- Hill and Treirweiller 1986 "Prehistoric Response to Food Stress on the Pajarito Plateau: Results of Pajarito Research Project." James N. Hill and Treirweiller. Manuscript to National Science Foundation by Pajarito Archaeological Research Project. University of California at Los Angeles, Department of Anthropology. 1986.
- Jenkins 1972 "Spanish Land Grants in the Tewa Area." M. E. Jenkins. *New Mexico Historical Review*. Vol. 47, No. 2, pp. 113-134. 1972.
- Jenkins and Schroeder 1974 *A Brief History of New Mexico*. M. E. Jenkins and A. H. Schroeder. University of New Mexico Press. Albuquerque, New Mexico. 1974.
- Kessell 1979 *Kiva, Cross, and Crown*. John L. Kessell. U.S. Department of the Interior, National Park Service. Washington, D.C. 1979.
- Kidder 1927 "Southwestern Archaeological Conference." A. V. Kidder. *Science*. Vol. 68, pp. 489-491. 1927.
- King 1993 "Beyond Bulletin 38: Comments on the Traditional Cultural Properties Symposium." T. King. Special Issue: *Cultural Resources Management Information for Parks, Federal Agencies, Indian Tribes, States, Local Governments, and the Private Sector*. Vol. 16, pp. 60-64. U.S. Department of the Interior, National Park Service, Cultural Resources Division. 1993
- Kohler 1989 "Bandelier Archaeological Excavation Project, Research Design and Summer 1988 Sampling," T. A. Kohler, ed. *Department of Anthropology Reports of Investigations*, No. 61. Washington State University. Pullman, Washington. 1989.
- LaFeber 1993 *America, Russia, and the Cold War, 1945–1992*, 7th edition. LaFeber. McGraw-Hill. New York, New York. 1993.
- Lange 1959 *Cochiti: A New Mexico Pueblo, Past and Present*, 1990 edition. Charles H. Lange. University of New Mexico Press. Albuquerque, New Mexico. 1959.

- LANL 1986–1995 “Cultural Resource Survey Report, No. 1 through No. 116.” Los Alamos National Laboratory, Cultural Resources Management Team. Los Alamos, New Mexico. 1986–1995.
- LANL 1995a *Capital Asset Management Process, Fiscal Year 1997*. Los Alamos National Laboratory. LA-UR-95-1187. Los Alamos, New Mexico. 1995.
- LANL 1995b *Decommissioning Summary Site Plan*, Attachment 7, pp. 26-41. Los Alamos National Laboratory, Environmental Restoration Project. Los Alamos, New Mexico. 1995.
- LANL 1995c *LANL Cultural Resource Electronic Database of Archaeological Sites*. Los Alamos National Laboratory. Los Alamos, New Mexico. 1995.
- LANL 1996 Electronic database files. Los Alamos National Laboratory, Facility for Information Management, Analysis, and Display (FIMAD). Los Alamos, New Mexico. 1995–1996.
- Larson 1991 *Data Recovery Plan for Seven Coalition Period Pueblos on Mesita Del Buey: Laboratory of Anthropology (LA) 4620, 4621, 4622, 4623, 4624, 4625, and 4626, Los Alamos National Laboratory, New Mexico*. Beverly M. Larson. Los Alamos National Laboratory, Environmental Protection Group (HSE-8), Health, Safety and Environment Division. Los Alamos, New Mexico. 1991.
- Leonard 1970 *The Role of the Land Grant in the Social Organization and Social Processes of a Spanish American Village in New Mexico*. Olen E. Leonard. Calvin Horn, ed. Albuquerque, New Mexico. 1970.
- Mathien et al. 1993 “The Pajarito Plateau: A Bibliography.” F. J. Mathien, C. R. Steen, and C. D. Allen. *Southwest Cultural Resource Center*. U.S. Department of Interior, National Park Service, Division of Anthropology. Professional Paper No. 49. Santa Fe, New Mexico. 1993.
- Maxon 1969 “A Study of Two Prehistoric Pueblo Sites on the Pajarito Plateau, New Mexico.” J. C. Maxon. Unpublished thesis presented to the faculty of the University of Wisconsin. 1969.
- McGehee 1995 *Decontamination and Decommissioning of 28 ‘S-Site’ Properties: Technical Area 16*. Ellen D. McGehee. Los Alamos National Laboratory. Cultural Resources Survey Report Number 84. Los Alamos, New Mexico. 1995.
- Meyer 1984 *Water in the Hispanic Southwest: A Social and Legal History 1550–1850*. Michael C. Meyer. The University of Arizona Press. Tucson, Arizona. 1984.

- Minge 1979 "Effectos del Pais: A History of Weaving Along the Rio Grande." W. A. Minge. *Spanish Textile Tradition of New Mexico and Colorado*. Nora Fisher, ed. Museum of New Mexico Press. Santa Fe, New Mexico. 1979.
- Minnis 1991 "Famine Foods of the Northern American Desert Borderlands in Historical Context." Paul E. Minnis. *Journal of Ethnobiology*. Vol. 11, No. 2, pp. 231-257. 1991.
- Moerman 1986 *Medicinal Plants of Native America*. Daniel E. Moerman. University of Michigan, Museum of Anthropology. Technical Report No. 19, Vols. 1 and 2. 1986.
- NAU and SWCA 1996 *Final Report, Animas-La Plata Ethnographic Study*, Vol. 1. Report prepared by Northern Arizona University, Flagstaff, Arizona, and SWCA, Inc., Environmental Consultants. Albuquerque, New Mexico. 1996.
- NMHPD 1995 *New Mexico State Register of Cultural Properties and National Register of Historic Places, Listings for Los Alamos County*. New Mexico Office of Cultural Affairs, Historic Preservation Division. Santa Fe, New Mexico. February 8, 1995.
- Nordhaus 1995 *Tipi Rings: A Chronicle of the Jicarilla Apache Land Claim*. Robert J. Nordhaus. Bowarrow. Albuquerque, New Mexico. 1995.
- NPS 1990 *Guidelines for Evaluating and Documenting Traditional Cultural Properties*, U.S. Department of the Interior, National Park Service, Interagency Resources Division. National Register Bulletin 38. Washington, D.C. 1990.
- Oakes 1997 C. L. Oakes, GRAM Team. Personal communication with Beverly Larson, Los Alamos National Laboratory, Cultural Resource Management Team. June 18, 1997.
- Parker 1993 "New Coalition Joins Park Fight," R. Parker. *Albuquerque Journal*, "Metro Plus" Section. pp. 1 and 4. Albuquerque, New Mexico. August 26, 1993.
- Parker and King 1990 *Guidelines for Evaluating and Documenting Traditional Cultural Properties*. Patricia L. Parker and Thomas F. King. U.S. Department of the Interior, National Park Service, Interagency Resources Division. *National Register Bulletin 38*. Washington, D.C. 1990.
- PC 1995 L. Voellinger, GRAM Team. Personal communication with Beverly Larson, U.S. Department of Energy. Los Alamos, New Mexico. December 18, 1995.
- PC 1996 L. Voellinger, GRAM Team. Personal communication with Lynn Sebastian, Deputy State Historic Preservation Officer. Santa Fe, New Mexico. February 21, 1996.

- Perlman 1995 *Fort Wingate Depot Activity Ethnographic Study*, Draft. Susan E. Perlman. University of New Mexico, Office of Contract Archeology. Albuquerque, New Mexico. 1995.
- Peterson 1977 *The Living Tradition of Maria Martinez*. Susan Peterson. Sunstone Press. Santa Fe, New Mexico. 1977.
- Powers 1988 *Archeological Research Design for a Sample Inventory Survey of Bandelier National Monument*. R. P. Powers. U.S. Department of the Interior, National Park Service, Branch of Cultural Research. Santa Fe, New Mexico. 1988.
- Powers and Orcutt 1988 *The Bandelier Survey, 1987*, Preliminary Report. R. P. Powers and J. D. Orcutt. U.S. Department of the Interior, National Park Service. Santa Fe, New Mexico. 1988.
- Pratt and Scurlock 1993 "New Mexico Historic Contexts." Boyd Pratt and Dan Scurlock. Manuscript on file at the New Mexico Office of Cultural Affairs, Historic Preservation Division. Santa Fe, New Mexico. 1993.
- Robbins et al. 1916 *Ethnobotany of the Tewa Indians*. W. W. Robbins, J. P. Huntington, and B. Freire-Marreco. Smithsonian Institution, Bureau of American Ethnology. Bulletin 55. Washington, D.C. 1916.
- Robinson et al. 1972 *Tree-Ring Dates from New Mexico I, O, V: Central Rio Grande Area*. W. J. Robinson, John Hannah, and Bruce Harrill. University of Arizona, Laboratory of Tree-Ring Research. Tucson, Arizona. 1972.
- Sando 1992 *Pueblo Nations: Eight Centuries of Pueblo Indian History*. J. S. Sando. Clear Light Publishers. Santa Fe, New Mexico. 1992.
- Schroeder 1979 "Pueblos Abandoned In Historic Times." A. H. Schroeder. *Handbook of American Indians, Southwest*. Alfonso Ortiz, ed. Smithsonian Institution. Vol. 9, pp. 236-254. Washington, D.C. 1979.
- Seidel 1995 *Los Alamos and the Development of the Atomic Bomb*. R. W. Seidel. Otowi Crossing Press. Los Alamos, New Mexico. 1995.
- Simmons 1979a "History of the Pueblos Since 1821." M. Simmons. W. C. Sturtevant, ed. *Handbook of North American Indians, Southwest*. Alfonso Ortiz, ed. Smithsonian Institution. Vol. 9, pp. 206-223. Washington, D.C. 1979.
- Simmons 1979b "History of Pueblo-Spanish Relations to 1821." *Handbook of North American Indians, Southwest*. Alfonso Ortiz, ed. Smithsonian Institution. Vol. 9, pp. 178-193. Washington, D.C. 1979.

- Starr 1900 “Shrines Near Cochiti, New Mexico.” Frederick Starr. *American Antiquarian*. Vol. 22, No. 4, pp. 219-223. 1900.
- Steen 1977 *Pajarito Plateau Archaeological Survey and Excavations*. C. R. Steen. Los Alamos Scientific Laboratory, U.S. Energy Research and Development Administration. Publication 77-4. Los Alamos, New Mexico. 1977.
- Steen 1982 *Pajarito Plateau Archaeological Surveys and Excavations, II*. C. R. Steen. Los Alamos National Laboratory. Los Alamos, New Mexico. 1982.
- Stuart and Gauthier 1981 *Prehistoric New Mexico: A Background for Survey*. David E. Stuart and Rory P. Gauthier. New Mexico Historic Preservation Bureau. Santa Fe, New Mexico. 1981.
- SWCA 1995 *Native American Concerns Regarding the Paseo Del Volcan Study Corridors*. Susan E. Perlman, Southwest Cultural Associates, Inc. Report to the Federal Highway Administration and the New Mexico State Highway and Transportation Department. 1995.
- SWCA 1996a *Initial Traditional Cultural Properties Study of Heron and El Vado Reservoirs, Rio Arriba County, New Mexico*. Susan E. Perlman, Southwest Cultural Associates, Inc. Report to the U.S. Bureau of Reclamation. Albuquerque, New Mexico. 1996.
- SWCA 1996b *A Study of Hispanic Traditional Practices Along the Paseo del Volcan Study Corridors, Bernalillo and Sandoval Counties, New Mexico*. David Phillips, Jr., and Kevin (Lex) Palmer, Southwest Cultural Associates, Inc. Report to the Federal Highway Administration and New Mexico State Highway and Transportation Department. Albuquerque, New Mexico. 1996.
- SWCA 1996c *Initial Traditional Cultural Properties Study of the White Ranch Property Saguache County, Colorado*. Susan E. Perlman, Southwest Cultural Associates, Inc. Report to the Bureau of Reclamation and the Fish and Wildlife Service, Albuquerque, New Mexico. 1996.
- SWCA 1996d *Initial Traditional Cultural Property Study of the Westland Sector Plan Bernalillo County, New Mexico*. Susan E. Perlman, Southwest Cultural Associates, Inc. Report to Westland Development Company and the Albuquerque Planning Department. Albuquerque, New Mexico. 1996.
- Toll 1983 *Wild Plant Use in the Rio Abajo: Some Deviations from the Expected Pattern Throughout the Central and Northern Southwest*. Mollie S. Toll. Paper presented at the Rio Abajo Area Conference Seminar on the Archaeology and History of the Socorro District, New Mexico Institute of Mining and Technology. Socorro, New Mexico. March 18–19, 1983.

- Toll 1992 "Patterns of Plant Use from the Late Prehistoric to Spanish Contact in the Rio Grande Valley." Mollie S. Toll. *Current Research of the Late Prehistory and Early History of New Mexico*. New Mexico Archaeological Council Special Publication. Vol. 1, pp. 51-54. 1992.
- Treib 1993 *Sanctuaries of Spanish New Mexico*. Marc Treib. University of California Press. Berkeley, California. 1993.
- Truslow 1991 *Manhattan District History: Nonscientific Aspects of Los Alamos Project Y, 1942–1946*. Edith C. Truslow. Kasha V. Thayer, ed. Los Alamos Historical Society. Los Alamos, New Mexico. 1991.
- Wallis 1994 *En Divina Luz: The Penitente Moradas of New Mexico*. Michael Wallis. University of New Mexico Press. Albuquerque, New Mexico. 1994.
- Weigle 1978 *Hispanic Villages of Northern New Mexico*. M. Weigle, ed. A reprint of one volume of the 1935 Tewa Basin Study. Jene Lyon, Publisher. Santa Fe, New Mexico. 1978.
- Wendorf 1954 "A Reconstruction of Northern Rio Grande Prehistory." Fred Wendorf. *American Anthropologist*. Vol. 56, pp. 200-227. 1954.
- Wetterstrom 1986 "Food, Diet and Population at Prehistoric Arroyo Hondo Pueblo, New Mexico." W. Wetterstrom. *Arroyo Hondo Archaeological Series*, Vol. 6. American Research Press. Santa Fe, New Mexico. 1986.
- Willey 1966 "An Introduction to North American Archaeology." Gordon R. Willey. Vol.1, *North and Middle America*. 1966.
- Wolfman 1994 *Jemez Mountains Chronology Study*. Daniel Wolfman. Museum of New Mexico, Office of Archaeological Studies. Santa Fe, New Mexico. 1994.
- Worman 1967 *Archaeological Salvage Excavations on the Mesita del Buey, Los Alamos County, New Mexico*. F. C. V. Worman. Los Alamos Scientific Laboratory. LA-3636. Los Alamos, New Mexico. 1967.
- Worman and Steen 1978 *Excavations on Mesita de Los Alamos*. F. C. V. Worman and C. R. Steen. Los Alamos National Laboratory. LA-7043-MS. Los Alamos, New Mexico. 1978.
- Young 1940 "Navajo Native Dyes: Their Preparation and Use." Stella Young. Recipes by Nonabah G. Bryan. Willard W. Beatty, ed. *Indian Handcrafts*, Vol. 2. U.S. Bureau of Indian Affairs. Chilocco, Oklahoma. 1940.

APPENDIX F

TRANSPORTATION RISK ANALYSIS

F.1 INTRODUCTION

Following in this appendix are more detailed descriptions of the transportation risk analysis methodology and results that are summarized in the main volume of the SWEIS.

Section F.2 includes a description of the types of radioactive material (RAM) packaging required by the regulations of the U.S. Department of Transportation (DOT), the U.S. Nuclear Regulatory Commission (NRC), and DOE, and examples of how packaging is used at LANL. Containers for hazardous materials (HAZMAT) are also described in section F.2. Risk measures are described in section F.3.

The methodology for quantifying the risk measures is described in section F.4. The methodology incorporates truck accident data with an emphasis on routes between Interstate 25 (I-25) and the LANL site; a computer program to determine routes, mileages, and associated population densities; and other computer codes to quantify incident-free exposures and accident doses.

The methodology for determining the numbers and types of shipments for the baseline and the identified SWEIS alternatives (No Action, Expanded Operations, Reduced Operations, and Greener) is described in section F.5.

The risk analysis results are presented in section F.6 for the base case and in section F.7 for the Santa Fe relief route case. To aid in understanding and interpreting the results, specific areas of uncertainty are described in section F.8, with emphasis on how the uncertainties may affect comparison of SWEIS alternatives.

F.1.1 Purpose of the Analysis

Although in DOT regulations (49 CFR 171.8) RAM is a subset of HAZMAT, for this transportation analysis they are addressed separately. The purpose of the transportation risk analysis is to address the human health risks arising from the transport of HAZMAT and RAM associated with the operation of LANL. The human health risks associated with truck traffic arise from exposure to the truck exhaust and the possibility of an accident that could produce injuries or fatalities. These two health risks are independent of the truck cargo and exist for similar shipments of any commodity.

The human health risks associated with the radioactive or hazardous cargo result from the possibility of release of the cargo in an accident. In addition, the radioactive cargo produces a radiation field external to the packaging even for normal conditions. Persons exposed to the external field receive a small level of radiation, referred to as incident-free exposure.

These health risks are characterized in terms of four risk measures: truck-related emissions, which could cause fatalities from latent cancer; fatalities and injuries due to collisions with heavy trucks; incident-free exposures to radiation, which could cause fatalities from latent cancer; and accidental releases of the radioactive or hazardous cargo, which could cause immediate or latent fatalities. These risk measures are described in section F.3, and the methodology used to quantify them is described in section F.4 of this appendix.

F.1.2 Scope of the Analysis

The scope of the analysis includes the transport of RAM or HAZMAT on public roads within the LANL site and off-site shipments of

materials by truck or air. Air shipments begin and end with a truck shipment. Rail transport is not addressed in this analysis, because there is no rail service to LANL. The risks to workers or to the public from loading or unloading trucks prior to or after shipment are considered part of normal facility operations and are not addressed as part of the transportation analysis (these are addressed in the analysis of worker health risks due to radiation exposure in sections 5.2.6, 5.3.6, 5.4.6, and 5.5.6); however, handling during shipment is included. Shipments while public roads are temporarily closed are also included in this analysis.

The methods and assumptions described in this appendix were selected to ensure meaningful comparisons among the SWEIS alternatives. A number of generic assumptions appropriate to the overview nature of the SWEIS were made. For example, because a detailed analysis of every type of LANL shipment would be impractical, shipments representative of classes of materials were selected as described in section F.5. Three examples of material class are bulk solid RAM, liquid RAM, and flammable materials. Also, because the different packaging used for RAM are too numerous to analyze individually to determine how severe an accident must be to cause a release, all packaging meeting the same regulatory criteria are assumed to fail at the same accident force magnitude (and hence probability). These parameters are described in subsection F.4.4.

In DOT regulations on the transportation of RAM, packaging is defined in 49 CFR 173.403 as:

...the assembly of components necessary to ensure compliance with the packaging requirements of this subpart. It may consist of one or more receptacles, absorbent materials, spacing structures, thermal insulation, radiation shielding, and devices for

cooling or absorbing mechanical shock.

A package is defined as “the packaging together with its radioactive contents as presented for transport.”

The general rule used in this appendix is that all assumptions should be conservative enough to ensure that the results do not underestimate the level of transportation risk, but not so conservative that the risk calculation is knowingly orders of magnitude too conservative or the differences between alternatives are obscured.

The focus of the transportation accident analysis is on bounding accidents; i.e., the most severe, reasonably foreseeable accidents (DOE 1994a). Transportation accidents that may occur often but that do not involve major consequences are not addressed.

F.2 PACKAGING OVERVIEW

DOT is the lead federal agency for establishing and enforcing regulations regarding safe transportation of HAZMAT and RAM. Procedures to ensure safe packaging for HAZMAT and RAM include categorizing the material and requiring the use of a packaging or container appropriate to the category. In the case of RAM, the categorization is by form, quantity, and concentration of RAM. The premise underlying packaging design for most HAZMAT and RAM is that the packages must maintain their integrity in the normal transportation environment, which includes minor accidents. An exception is that highly RAM and their packaging must survive severe accident conditions without a dangerous release of contents. Because packaging represents the primary barrier between HAZMAT and RAM being transported and exposure of the public and the environment, the regulatory approach for ensuring safety is to specify standards for the packaging of HAZMAT and RAM. These

packaging requirements are an important consideration for the transportation risk assessment, and typical packaging used at LANL are described in this section. Packaging and vehicles used for RAM are described first; then chlorine cylinders, propane cargo tanks, and explosives packaging are described.

DOT sets design and performance specifications for packaging that will carry up to Type A quantities of RAM. Under an agreement with DOT, NRC sets the standards for packages of Type A and Type B quantities of RAM (subsections F.2.3 and F.2.4). DOE meets NRC's standards for certain packages and follows DOT's regulations for shipping and packaging or provides equivalent protection for its shipments. Examples of general RAM packages are shown in Figure F.2-1.

F.2.1 Limited Quantity Packaging

Limited quantities are very small amounts of radioisotopes such as amounts found in smoke detectors, lantern mantles, watches, signs, and measuring devices. The level of radioactivity listed in 49 CFR 173.425 is so low that materials containing that level can be shipped without special packages, shipping papers, markings, and labeling requirements. The materials are packaged in accordance with the general design requirements of 49 CFR 173.410. Such packages must be designed for ease of handling and proper restraint during shipment. They must be free of protuberances, easily decontaminated, and capable of withstanding the effects of vibration during transport. All valves, through which the package contents could escape, must be protected (60 Federal Register [FR] [188] 50297).

F.2.2 Industrial Packaging

Industrial packaging (IP) are authorized as packaging for low-specific-activity (LSA) materials and surface-contaminated objects

(SCOs). LSA materials are naturally occurring ores, concentrates, and other materials in which the activity is essentially uniformly distributed at low levels. In contrast, materials classified as SCO are not inherently radioactive; rather, they are objects with radioactive contamination on their surfaces, also at very low levels of activity. At a minimum, each IP must meet the general design requirements of 49 CFR 173.410: it must be designed for ease of handling and proper restraint during shipment; it must be free of protuberances, easily decontaminated, and capable of withstanding the effects of vibration during transport; and valves, through which the contents could escape, must be protected. These are the only requirements that apply to IP Type 1 (IP-1) (60 FR [188] 50297).

IP Type 2 (IP-2) must also survive the Type A free drop and stacking tests. Each IP Type 3 (IP-3) must meet the requirements for IP-1 and IP-2 and the following Type A package requirements (DOT 1995b):

- A seal must be incorporated on the outside of the packaging.
- Temperatures must be within a specified range.
- A containment system that is securely closed by a positive fastening device must be included.
- Any radiolytic decomposition of materials and generation of gas by chemical reaction and radiolysis must be taken into account.
- Radioactive contents must be retained under reduced pressure.
- Each valve (except a pressure-relief device) must have an enclosure to retain any leakage.
- Shielding must remain in place to protect the packaging components.
- The failure of any tie-down attachment must not impair the ability of the package to meet other requirements.
- No loss or dispersal of the radioactive contents or any significant increase in the

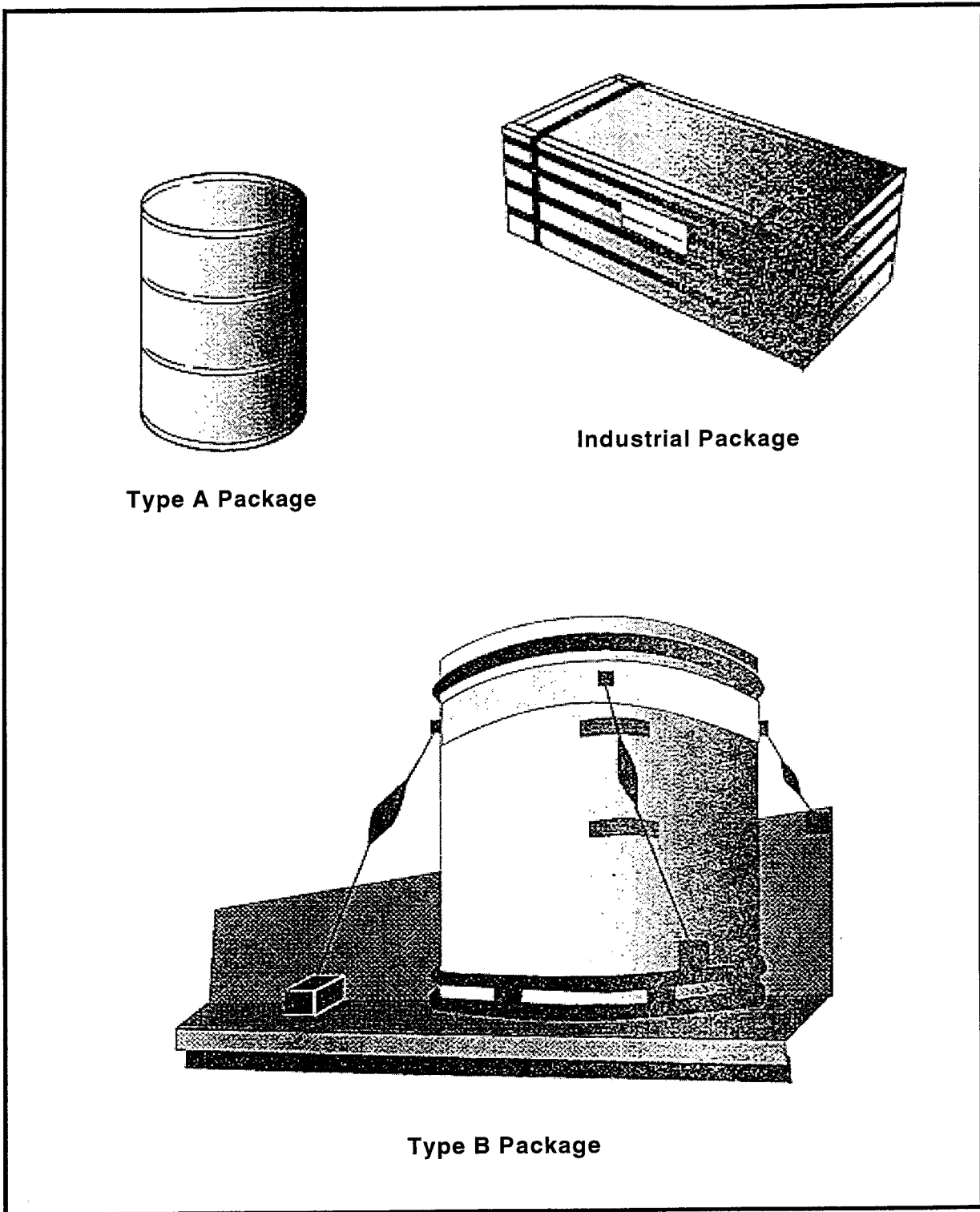

SOURCE: DOE 1996a

FIGURE F.2-1.—Examples of Packaging Types.

radiation levels at the external surfaces must occur when the IP-3 is evaluated against Type A packaging tests.

Solid depleted uranium is packaged in Type IP-1 packaging. Water with tritium concentrations up to 75.7 curies per gallon (20 curies per liter) is packaged in Type IP-2 packaging for exclusive-use shipments and Type IP-3 packaging for nonexclusive-use shipments. An exclusive-use shipment is one that is for the sole use of the consignor or consignee. SCOs such as decontamination and decommissioning wastes are packaged in Type IP-1 if the fixed alpha contamination is up to 6.45×10^{-7} curies per square inch (10^{-7} curies per square centimeter) and Type IP-2 if the fixed alpha contamination is up to 1.3×10^{-5} curies per square inch (2×10^{-6} curies per square centimeter) (60 FR [188] 50297).

F.2.3 Type A

Type A packaging are used for RAM with specific activities up to limits specified in the regulations. Type A packages must contain RAM under normal transportation conditions and must maintain sufficient shielding to limit exposure of handling personnel. Normal transportation refers to all transportation conditions except those resulting from major accidents or sabotage. Type A packages are generally steel drums or boxes made of steel, wood, or strong fiberboard (see Figure F.2.3-1 for an example of a Type A package). The packaging, with contents, must be capable of withstanding a series of tests (49 CFR 173.465) including: water spray, free drop (as high as 4 feet [1.2 meters], depending upon mass), compression, and penetration.

F.2.4 Type B

Type B containers are very durable packages used to contain and shield more hazardous amounts and forms of RAM than those contained in Type A packages. Type B

packages are used to transport materials such as spent fuel and high-level radioactive waste that would present a radiation hazard to the public or the environment if a major release occurred. Type B packages must provide protection under both normal conditions of transport and severe accidents. The certified design and construction methods for Type B packages ensure the production of systems that will contain the packaged radioactive contents even after a series of rigorous accident tests. The tests for hypothetical accident conditions specified in 10 CFR 71.73 include free drop (30 feet [9 meters]), crush, puncture, thermal (exposure to 1,475°F [802°C] for 30 minutes), and immersion. The size of Type B packages can range from 40 pounds (18 kilograms) to over 100 tons (91 metric tons). Examples of Type B packages are presented in the following subsections.

F.2.4.1 *FL-Type Container*

The FL-Type container is currently the only certified container used for pit transport. It is a DOT Type B package with a 16-gage stainless steel outer containment drum surrounding a 12-gage stainless steel inner containment drum (Figure F.2.4.1-1). Fiberboard insulation is present between the inner and outer containment drums. Both the internal and external containment drums are constructed of stainless steel. The inner containment vessel is sealed with dual concentric silicone O-rings (DOE 1996c).

F.2.4.2 *Transuranic Packaging Transporter for Contact-Handled Transuranic Waste*

Contact-handled (CH) transuranic (TRU) waste is contaminated with man-made RAM with atomic numbers greater than uranium, such as plutonium, americium, and curium, which primarily emit alpha radiation. Because this type of radiation cannot penetrate human skin,

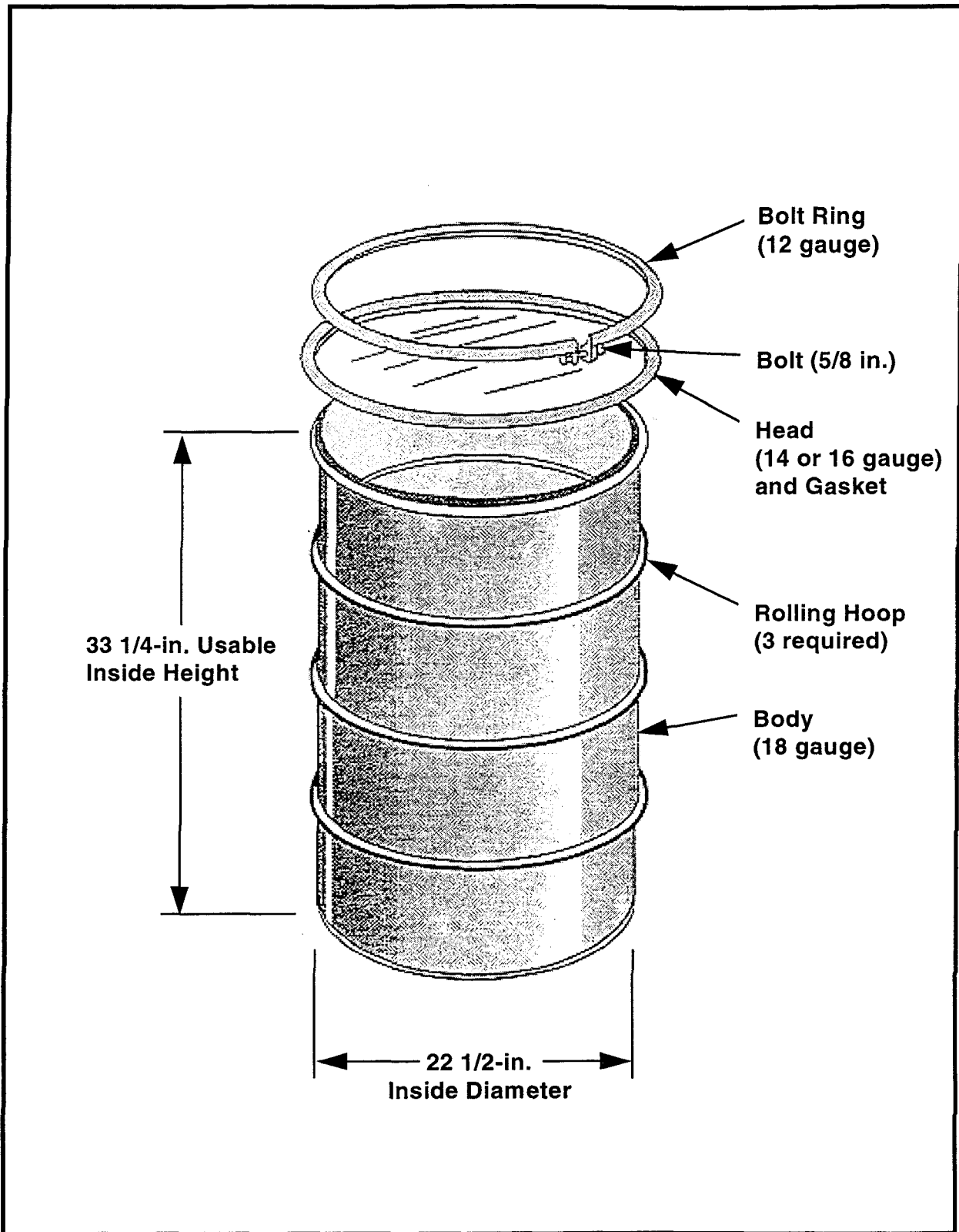
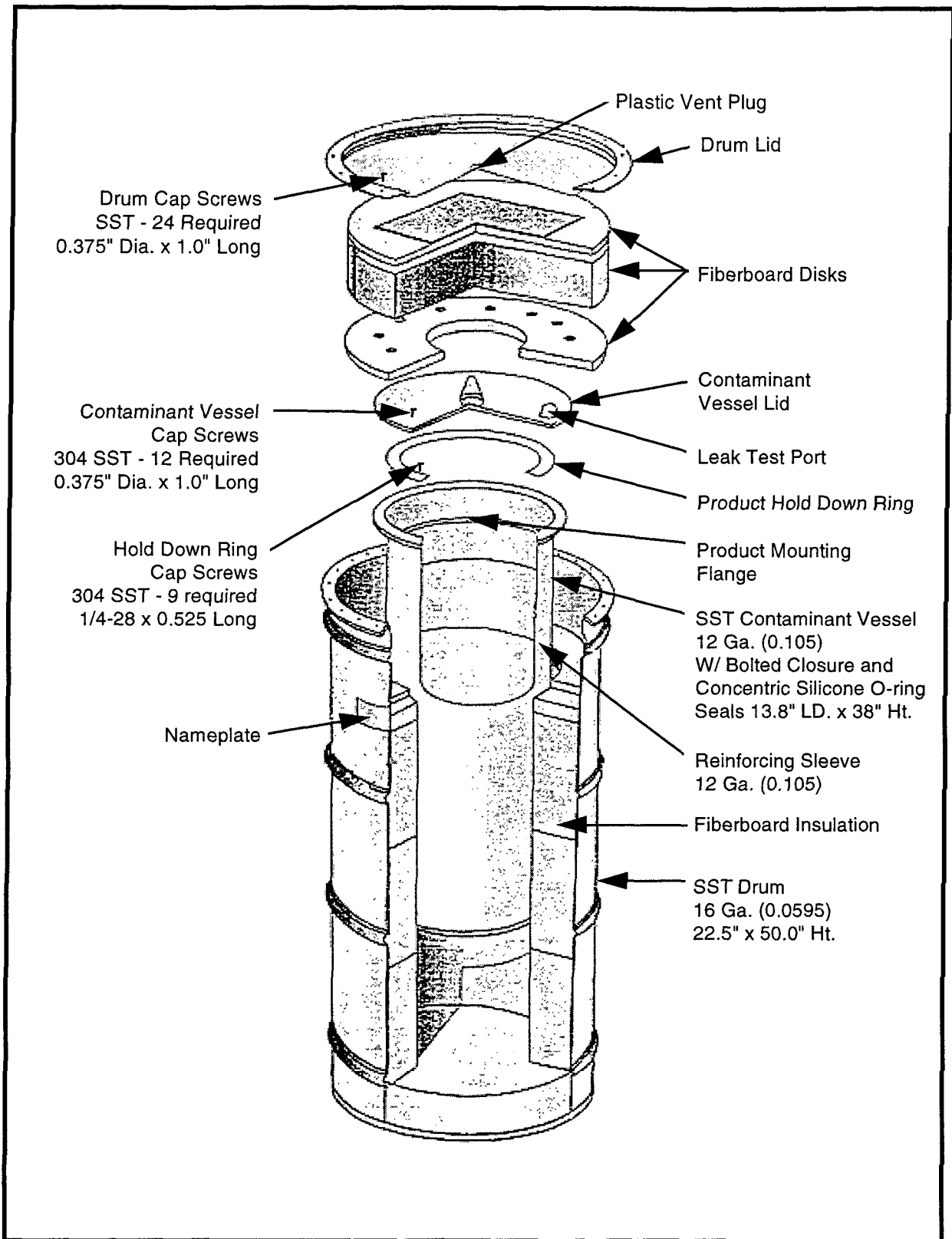

FIGURE F.2.3-1.—Type A DOT-17H 55-Gallon (208-Liter) Steel Drum.



SOURCE: DOE 1996c

FIGURE F.2.4.1-1.—Cross Section of an FL-Type Container.

CH TRU waste is a hazard only if inhaled or ingested. The waste includes such materials as laboratory clothing, tools, glove boxes, plastic, rubber gloves, wood, metals, glassware, and solidified wastewater sludges contaminated with TRU materials. All CH TRU waste will be transported to the Waste Isolation Pilot Plant (WIPP) in the Transuranic Packaging Transporter (TRUPACT-II), a reusable shipping packaging. NRC certified this Type B package according to 10 CFR 71. As part of the certification process, full-scale TRUPACT-II prototypes were subjected to actual drop and fire tests to prove their ability to survive severe accident conditions.

The TRUPACT-II is a cylindrical metal container with a flat bottom and a domed top that is transported in an upright position (Figure F.2.4.2-1). Multi-layered wall design increases the package strength and provides the ability to withstand potential transportation incidents. The CH waste will be sealed in 55-gallon (208-liter) steel drums or waste boxes. Each TRUPACT-II can hold up to fourteen 55-gallon (208-liter) steel drums, or two standard waste boxes (WGA and DOE 1995).

F.2.4.3 UC-609 for Tritium

The UC-609 package consists of a containment vessel centered by fiberboard insulation inside a 100-gallon (379-liter) drum (Figure F.2.4.3-1). The tritium contents are carried in a storage vessel inside the containment vessel. The package gross weight is 500 pounds (227 kilograms). The drum is fabricated of 14-gage Type 304 stainless steel. The Type 316 stainless steel containment vessel is 18 inches (45 centimeters) in diameter and 44 inches (112 centimeters) long and is rated for service at 110 pounds per square inch (6.36 kilograms per square centimeter), gage (psig) at 293°F (145°C). To protect the storage vessel from the effects of an accident, the annular space between the storage vessel and the containment

vessel wall is filled with aluminum honeycomb to absorb impact.

The allowable contents of the UC-609 is tritium in any form (except activated luminous paint) contained in a storage vessel. The maximum quantity of RAM per package is not more than 5.3 ounces (150 grams) of tritium with the decay heat not to exceed 48 watts. The oxygen content must be less than 5 percent by volume of the gas in the containment vessel. The maximum internal pressure of the containment vessel must not exceed 110 psig at 293°F (145°C) (Wangler 1995).

F.2.4.4 DOT-6M

The DOT-6M container is a metal packaging conforming to DOT Specification 6M (49 CFR 178.354). The sizes and payloads of DOT-6M containers vary. The rated capacity is not less than 10 gallons (38 liters) and no more than 110 gallons (416 liters) for the outer steel drum. The capacity of the inner containment vessel is not less than 0.33 gallon (1.24 liters). The inner containment vessel must conform to specification 2R or equivalent, with a maximum usable inside diameter of 5.25 inches (13.33 centimeters), a minimum usable inside diameter of 4 inches (10 centimeters), and a minimum height of 6 inches (15 centimeters). The inner containment vessel must be fixed within the outer shell by machined disks and rings made of solid industrial cane fiberboard, hardwood, or plywood. DOT Specification 6M metal packaging is used only for solid or gaseous RAM that will not undergo pressure-generating decomposition at temperatures up to 250°F (121°C) and that do not generate more than 10 watts of radioactive decay heat (49 CFR 173.416). A 55-gallon (208-liter) 6M packaging is shown in Figure F.2.4.4-1.

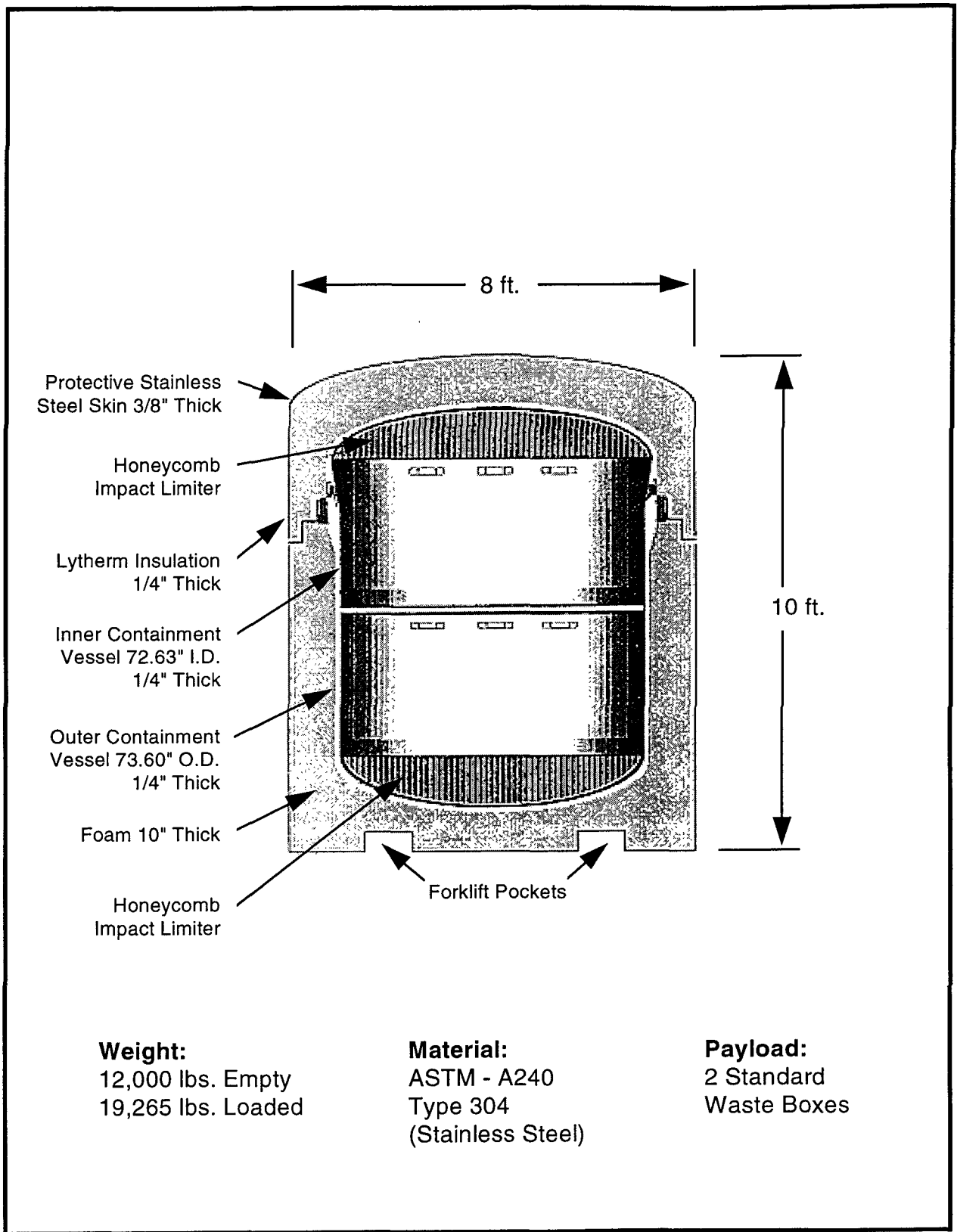
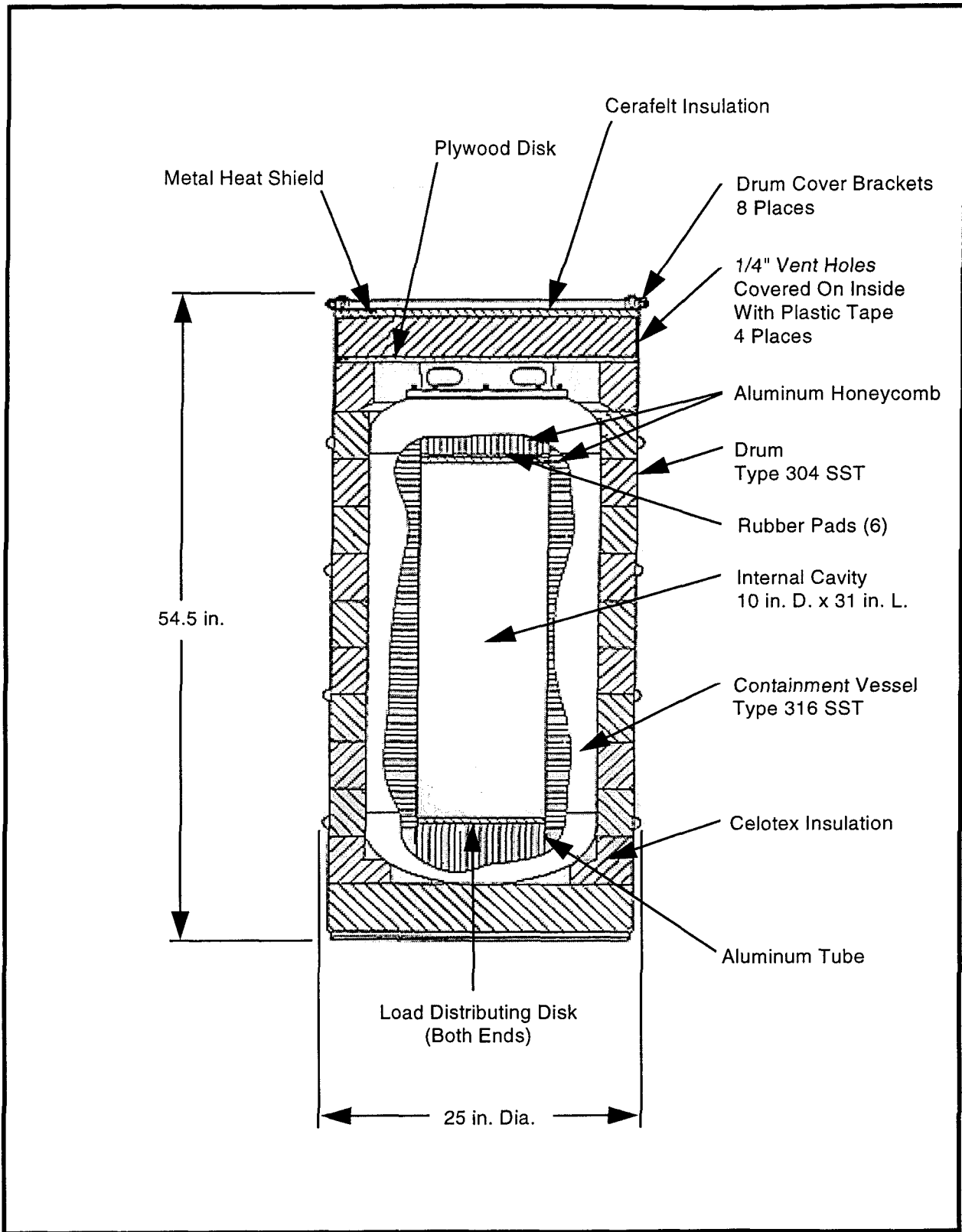
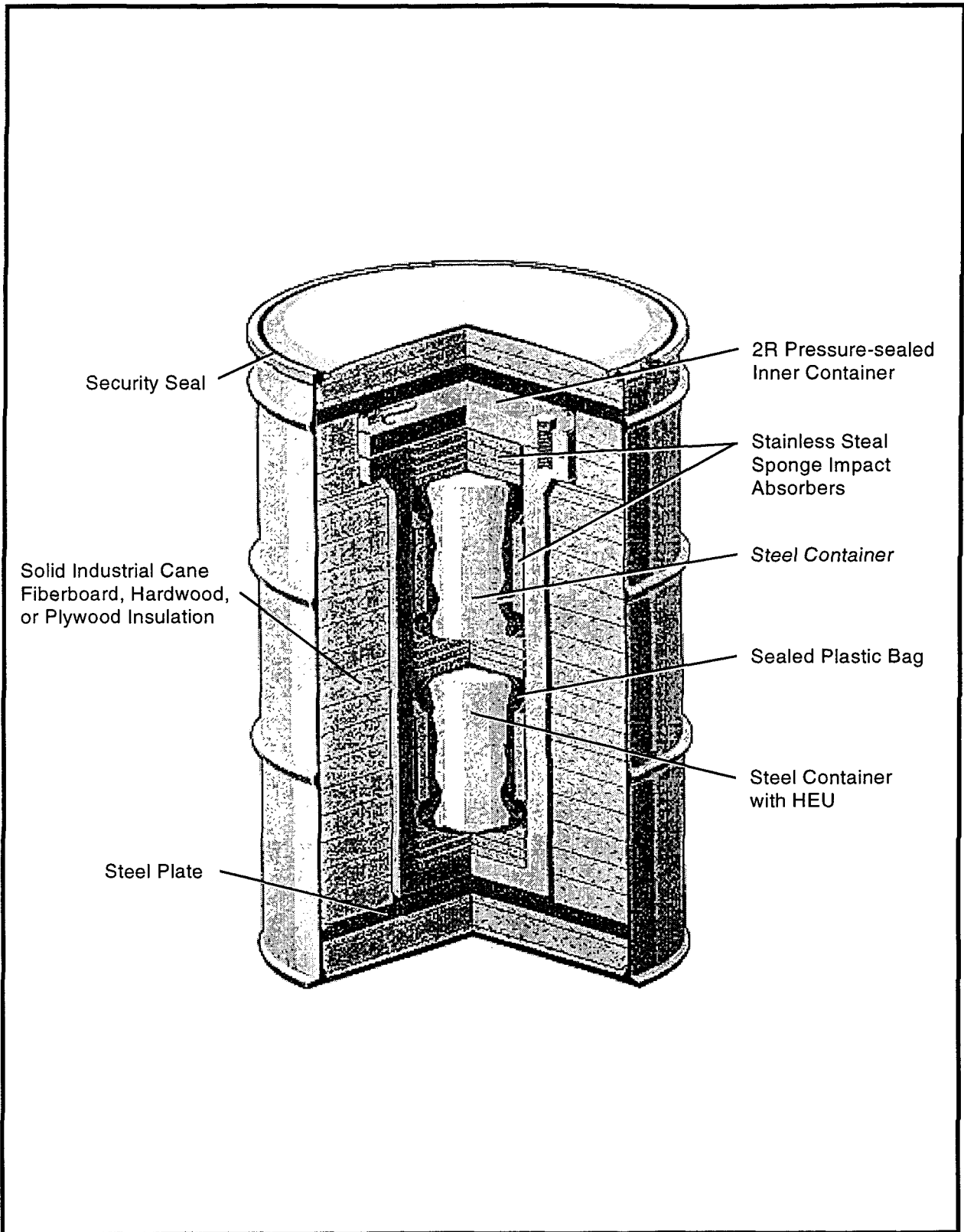

FIGURE F.2.4.2-1.—TRUPACT-II.



SOURCE: Wangler 1995

FIGURE F.2.4.3-1.—Model No. UC-609 Shipping Package.



SOURCE: DOE 1996b

FIGURE F.2.4.4-1.—55-Gallon (208-Liter) 6M Packaging.

F.2.4.5 ***5320 for Plutonium Oxide and Americium Oxide***

The basic arrangement of the 5320 shipping cask is an upright cylinder with a domed top (see Figure F.2.4.5–1). The weight of the cask is about 327 pounds (149 kilograms), the overall height is 32 inches (81.3 centimeters), and the diameter is 16.75 inches (42.55 centimeters). The cask cavity has a length of 17.5 inches (44.5 centimeters) and a diameter of 1.73 inches (4.39 centimeters). The nested primary and secondary containment vessels are surrounded by a finned aluminum shield tank filled with water-filled polyester. The containers are retained within the central sleeve of the shield tank by a bolt that holds the bottom of the secondary container against the baseplate. Heat from the package contents is conducted to the outer shell of the shield tank by radial aluminum plates that connect the central sleeve to the outer shell. Axial fins on the outer shell dissipate the heat to the environment. An expanded metal screen encloses and protects the fins. The screen also excludes personnel contact during handling operations.

A thermal shield protects the lid, flanges, flange bolts, and seals of the secondary container during thermal accident conditions. A “top hat” style impact limiter protects all of these components during impact accidents.

Secondary containment is provided by the EP–62, which is a cylindrical pressure vessel fabricated from Type 304 stainless steel. Primary containment is provided by the EP–61, which is a Type 316 stainless steel pressure vessel with a threaded plug and cap. The containment seal is provided by seal welding the cap to the body. The EP–61 is certified as a one-time-use container. It is opened by removing the welded cap, thus exposing the threaded plug. Energy absorbers are used to center the primary containment vessel inside the secondary containment vessel.

The americium and plutonium products placed inside handling or product canisters are contained in the primary containment vessel. Possible contents include plutonium oxide and its daughter products or americium oxide in any solid form such as granules, scrap, pellets, or powder. The maximum quantity allowed is 12.6 ounces (357 grams) of plutonium of any isotopic composition or 6.2 ounces (176 grams) of americium. The maximum permissible decay heat is 203 watts (Wangler 1996).

F.2.4.6 ***Model 72–B for Remote-Handled Transuranic Waste***

Packaging for remote-handled (RH) TRU waste, which produces penetrating gamma radiation, is now going through the certification process. Compliance with the NRC requirements for Type B packaging has to be demonstrated for the 72–B cask by analysis or by combination of analysis and testing. The 72–B cask is a scaled-down version of the 125–B package, which has been certified by the NRC as a Type B package.

The 72–B (Figure F.2.4.6–1) consists of two concentric stainless steel containment vessels protected by impact limiters at each end. A 2-inch (5-centimeter) lead liner between the inner and outer containment vessels provides shielding against gamma radiation. Neither containment vessel is vented, and each is capable of withstanding an internal pressure of 150 psig. The capacity of the 72–B cask is 8,000 pounds (3,632 kilograms) of payload. The payload consists of RH TRU waste packed in 30- or 55-gallon (114- or 208-liter) drums, which are contained in a carbon steel canister. A shipment of RH TRU waste will involve only one 72–B cask, loaded onto a custom-designed trailer, for truck transport to WIPP (SSEB 1994).

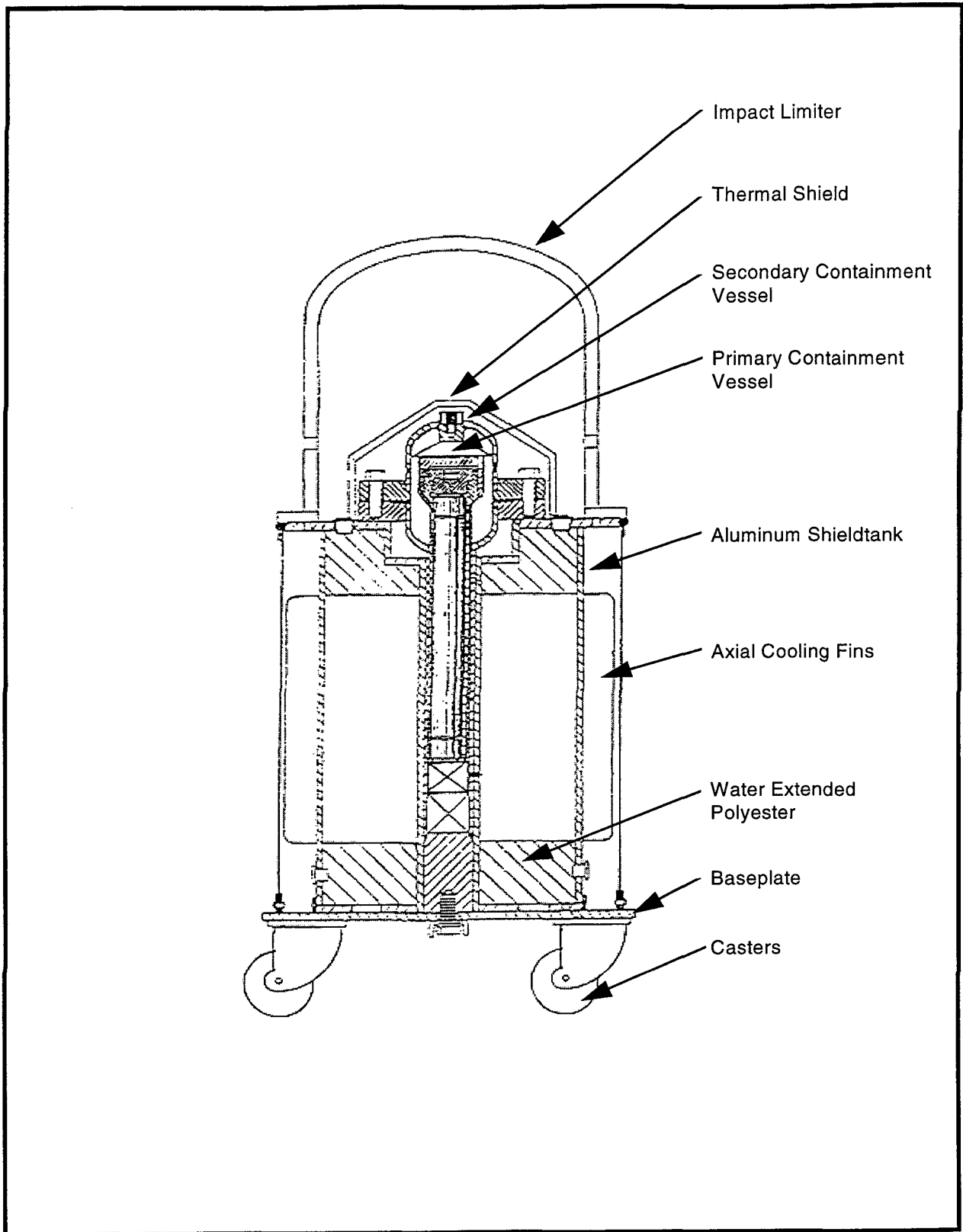

SOURCE: Wangler 1996

FIGURE F.2.4.5-1.—5320 Plutonium Oxide and Americium Oxide Shipping Cask.

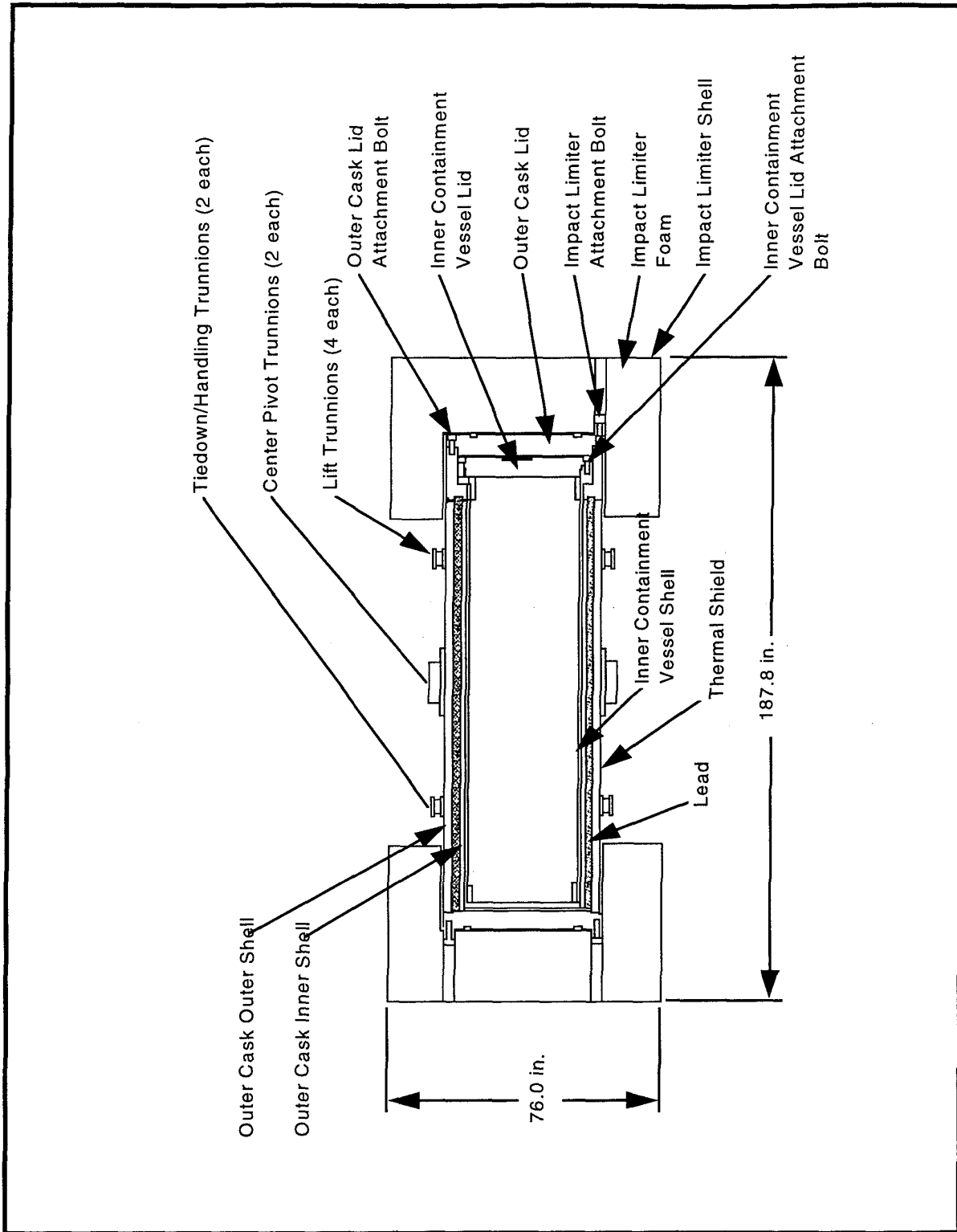

FIGURE F.2.4.6-1.—Cross Section of Model 72-B Cask.

F.2.5 Safe Secure Trailers

DOE maintains and operates a special fleet of trucks and trailers used to transport, in a safe and secure manner, SNM, classified configurations of nuclear weapons systems, and other forms and quantities of strategic materials between U.S. Department of Defense (DoD) sites and DOE production sites, laboratories, and test sites. DOE Albuquerque Operations Office, Transportation Safeguards Division, is responsible for the operation and maintenance of safe secure transport (SST) trailers and supporting vehicles. Because DOE exclusively operates and maintains the SST network, DOE is responsible for evaluating and approving the safe and secure use of the SSTs, both within DOE sites and between sites.

An SST trailer is a modified standard closed semi-trailer that includes necessary cargo tie-down equipment and temperature monitoring, fire alarm, and access denial systems. It is essentially a mobile vault that is highly resistant to unauthorized entry and provides a high degree of cargo protection under accident conditions. The SST trailer is pulled by an armored, penetration-resistant tractor.

SST trailers are accompanied by armed couriers in escort vehicles equipped with communications and electronics systems, radiological monitoring equipment, and other equipment to enhance safety and security. The escort vehicles must meet maintenance standards significantly more stringent than those for similar commercial transport equipment. All vehicles undergo an extensive maintenance check prior to every trip, as well as periodic preventive maintenance inspections. In addition, these vehicles are replaced more frequently than the vehicles used by commercial shippers. Every effort is made to ensure that the convoys do not travel during periods of inclement weather. Should the convoys encounter adverse weather, provisions exist for

the convoys to seek secure shelter at previously identified facilities (DOE 1996a).

F.2.6 1-Ton Chlorine Containers

Chlorine is categorized as a Division 2.3 material by DOT. This division is composed of gases that are considered poisonous when inhaled (49 CFR 173.115[c]).

Regulations allow transport of chlorine by rail tank car, tank truck, 1-ton (908-kilogram) container, and gas cylinder. Only 1-ton (908-kilogram) containers and smaller gas cylinders have been used at LANL. (One-ton cylinders are no longer used at LANL as they once were; this type of container is retained for analysis because one cannot preclude their future use.) DOT specification classes for the 1-ton (908-kilogram) container are 106A and 110A. The typical chlorine 1-ton (908-kilogram) container is 81.5 inches (207 centimeters) long with an outside diameter of 30.1 inches (76.5 centimeters). The minimum actual wall thickness is usually 0.4375 inch (1.1 centimeters) (the regulatory minimum is 0.406 inch [1.0 centimeter]). The ends of the cylinder are recessed to protect valves, which are also covered by a protective bonnet. Fusible plugs in both ends are designed to open if the temperature exceeds 155°F (68°C). The capacity is 2,000 pounds (908 kilograms) of chlorine.

F.2.7 Liquid Propane Cargo Tank

Liquid propane is transported by rail tank car, tank truck, and cargo tank. The cargo tank is used primarily for local deliveries and will transport up to 2,500 gallons (9,463 liters) of liquid propane. Deliveries to LANL are by cargo truck and are usually in 2,000-gallon (7,570-liter) increments. The cargo tank is 15 feet (4.6 meters) long and 6 feet (1.8 meters) in diameter. Its walls are 0.394 inch (1.0 centimeter) thick. The tank is permanently mounted on a 14-ton (12,712-kilogram) truck

body. Valves and piping are located at the rear of the truck. The tank pressure of 250 psi keeps the propane in a liquid state.

F.2.8 Explosives

Explosives are classified as Divisions 1.1 through 1.6 materials:

- *Division 1.1*—Materials that present a mass explosion hazard.
- *Division 1.2*—Materials that present a projection hazard, but not a mass explosion hazard.
- *Division 1.3*—Materials that present a fire hazard and a minor blast or project hazard (or both), but not a mass explosion hazard.
- *Division 1.4*—Materials that present minor explosion hazard.
- *Division 1.5*—Materials that present a mass explosion hazard, but that are also considered insensitive in terms of initiation of explosion.
- *Division 1.6*—Materials that are considered extremely insensitive and do not present a mass explosion hazard.

In the past, shipments to and from LANL have included materials in Divisions 1.1, 1.2, and 1.4.

Typical packages transported to LANL contain 50 pounds (22.7 kilograms) of explosives in a No. 4 fiber carton with a 4-millimeter-thick polyethylene liner. Up to 36 cartons are stacked on a wooden pallet and restrained by stretch netting. Up to 38,800 pounds (17,615 kilograms) of explosives may be transported to LANL in a tractor trailer.

F.3 RISK MEASURES

In this section, basic risk concepts are presented, key features of the transportation quantitative risk analysis are discussed, and the four risk measures used in the transportation risk analysis

are described. The transportation risk analysis methodology is illustrated in Figure F.3–1.

F.3.1 Risk Concepts

The terms hazard and risk are synonymous in everyday usage but are quite different in technical language. A hazard is the inherent characteristic of a material, condition, or activity that has the potential to cause harm to people, property, or the environment. A tank pressurized with air has the potential to cause harm to people from flying fragments that would result should the tank fail. An unpressurized tank filled with HAZMAT has the potential to cause harm because of the hazardous nature and quantity of material that could be released.

Risk is the combination of the likelihood and the consequence of a specified hazard becoming uncontrolled. The specified uncontrolled hazard is the result of an accident scenario. A scenario usually consists of a sequence of events. The events are sometimes shown graphically in an event tree (section F.4.5). Likelihood can be expressed as either a frequency or a probability. Frequency is the rate at which events occur (e.g., events per year, accidents per mile). The frequency component of risk often consists of the initiating event frequency multiplied by several conditional probability terms. A probability is a number between 0 and 1 that expresses a degree of belief concerning the possible occurrence of an event. In this appendix, the term probability usually reflects a conditional probability. A conditional probability is a probability for an event that has been preceded by one or more specified events. Consequence is the direct effect, usually undesirable, of the accident scenario. Consequences usually are measured in health effects but may be expressed as cost of property loss or the amount of HAZMAT released.

Risk often is defined as frequency times consequence. However, important information

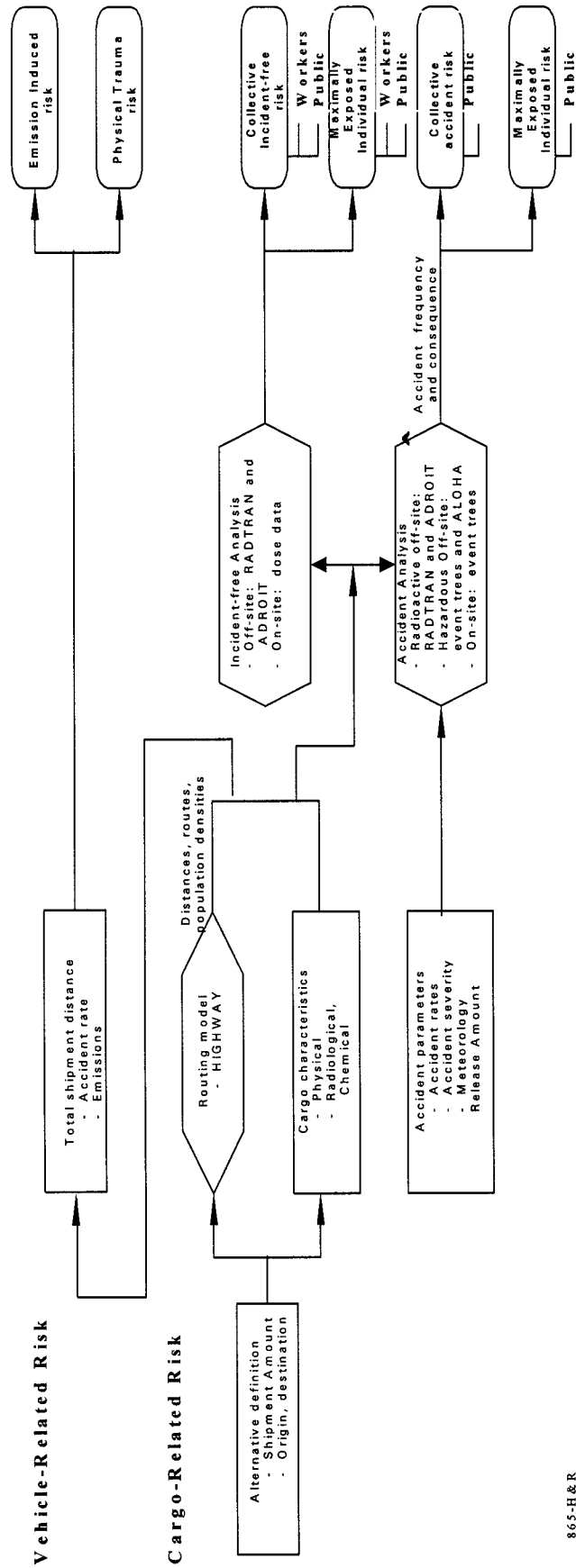

865-H&R

FIGURE F.3-1.—Transportation Risk Analysis Methodology.

may be lost when risk is expressed as the product of frequency and consequence. When frequency (or probability) is multiplied by consequence, an accident that is expected to cause one fatality and occur 10 times a year has the same mathematical risk as an accident that is expected to cause 1,000 fatalities and occur once every 100 years. Impact analysis results reported as risk values in sections F.6 and F.7 are the products of frequency and consequence to be consistent with the computer codes used to generate the results.

A quantitative risk analysis incorporates numerical estimates of the frequencies and the consequences in a sophisticated but approximate manner. In practice, few decisions require quantification of both frequency and consequence at equal levels of sophistication. Although risk assessment and risk analysis usually are used interchangeably, risk analysis is defined in the SWEIS as the computation of risks, whereas risk assessment is defined as the determination of risk acceptability. Taking action to mitigate risks is part of risk management.

F.3.2 Transportation Risk Key Parameters

A mathematical formulation specifically for transportation risk will illustrate the important parameters used in this appendix. The risk, R_i , for accident scenario i is a function of the scenario frequency, F_i , and the scenario consequence, C_i (Equation F-1).

$$R_i = f(F_i, C_i) \quad (\text{F-1})$$

The usual procedure for a quantitative transportation risk analysis is to divide the transport route into segments (also called links), along which the important parameters can be reasonably approximated by a single average value. A detailed expression for risk can then be formulated as follows (Equation F-2) (Rhyne 1994a):

$$R_i = f(F_{1a} \times M_a \times P_{2ab} \times P_{3abc} \times P_{4ad} \times P_{5ae}, N_{ad} \times A_{abc} \times X_{ace}) \quad (\text{F-2})$$

Where: F_{1a} = frequency of an accident per mile in transport link a , based, in the case of truck transport, primarily on highway type and conditions, vehicle type, and traffic conditions;

M_a = number of miles, or miles per year, in link a ;

P_{2ab} = probability that the accident in link a results in accident forces of type b (e.g., mechanical or thermal forces);

P_{3abc} = probability that the magnitude of accident force type b in link a exceeds the container's capability to resist the force and causes release class c to occur;

P_{4ad} = probability that population distribution class d occurs in link a ;

P_{5ae} = probability that meteorological condition e occurs in link a ;

N_{ad} = number of persons per unit area in population class d in link a ;

A_{abc} = release amount for release class c , given that force type b occurs in link a ; and

X_{ace} = area that experiences the specified health effects from a unit release of the hazardous material for meteorological condition e for release class c .

The overall risk is obtained by summing all scenarios for each link or for the entire route (Equation F-3).

$$R = \sum R_i \quad (\text{F-3})$$

The risk expression (Equation F-2) shows that risk is directly proportional to nine parameters, the quantification of which is described in section F.4 of this appendix. The key parameters affecting the frequency term are accident rate (subsection F.4.2), mileage (subsection F.4.3), and accident severity and package release probabilities (subsection F.4.4.2). The key parameters affecting the consequence term are population density (subsection F.4.3), release amount (subsection F.4.4.3), and meteorological conditions.

Two of the parameters in Equation F-2 (specific population density and specific meteorology) are not mentioned in section F.4. These conditional probabilities are conservatively valued as 1.0 in this transportation risk analysis.

F.3.3 Truck-Related Risk Measures

Trucks carry cargo as varied as radioactive and HAZMAT, steel girders, and vegetables. Truck traffic on public highways presents two types of health risks independent of the nature of the cargo: the health effect of air pollutants, primarily the diesel fuel combustion products; and the injuries and fatalities caused by truck accidents.

F.3.3.1 Truck Emissions

Truck traffic produces air pollution from the diesel engine exhaust, fugitive dust generated by the vehicle wake on the highway surface dust, and particulates from tire wear on the paved surface. The primary health effect of diesel fuel combustion is caused by sulfur oxides and particulates, although nitrogen oxides and hydrocarbons are also produced.

The health effect of these pollutants is increased sickness (morbidity) and death, generally occurring after a latency period of several years. The health effect has been evaluated by Rao, et al. (1982) as 1.0×10^{-7} fatalities per truck kilometer in urban areas. No analysis was made for morbidity because no data were available. The result is limited to urban areas because the available air pollution mortality data were limited to metropolitan population subgroups.

To evaluate this risk measure, the number of truck miles in urban areas (evaluated as described in subsection F.4.3) associated with RAM and HAZMAT shipments is multiplied by the health effect conversion factor described in the previous paragraph. Given truck travel in an urban area, the frequency of this consequence is 1; i.e., it is certain to occur.

F.3.3.2 Truck Accident Injuries and Fatalities

A truck accident can result in only minor property damage (fender bender) or major property damage, an injury to the truck driver or a member of the public, or a fatality. Saricks and Kvitek (1994) give state-by-state truck accident, fatality, and injury rates. The values used in the primary study area, in conjunction with the accident rates given in subsections F.4.2.2 and F.4.2.3, are 0.21 for the conditional probability of an injury in a truck accident, and 0.01 for the conditional probability of a fatality in a truck accident (DOT 1995a). To evaluate this risk, the appropriate truck accident rate (subsection F.4.2) is multiplied by the number of truck miles (subsection F.4.3).

F.3.4 Cargo-Related Risk Measures

The cargo-related health effects are a result of the intrinsic nature of the cargo; i.e., radioactive material and HAZMAT. HAZMAT presents no health risk unless the material is released in an accident. RAM can present a health risk caused

by release in an accident as well as by the normally occurring (incident-free) low-level radiation field external to the packaging. The latter is referred to as incident-free risk.

F.3.4.1 *Incident-Free Risk Measure (Radioactive Materials Only)*

The doses to three groups of the public, truck and air crew members, and to the maximally exposed individual (MEI) are quantified separately for the SWEIS. Each of the dose calculations is based on parameters such as the number of shipments and the radiation level of the shipments. Either the RADTRAN or the ADROIT computer codes described in subsection F.4.4 is used to perform the calculations. The collective doses are expressed in person-rem, and the MEI dose is expressed in rem; the conversion from person-rem and rem to human health effects is described in subsection F.4.4.5. The dose calculations are described in the following subsections.

People Along the Truck Route

The dose each person would receive depends on his or her distance from the highway and the speed of the truck as it passed. The already low radiation level at the truck would drop off rapidly as distance from the truck increased. Also, the faster the truck passed, the less time there would be for people to be exposed. The collective doses are calculated for all people living or working within 0.5 mile (0.8 kilometer) on each side of the highway for each route considered.

People Sharing the Truck Route

People in vehicles traveling in the same or the opposite direction as the shipment, as well as people in vehicles passing the shipment, would have the potential for close exposure to the radiation level from the truck. The collective doses are calculated by considering traffic count

and vehicle speeds for rural, suburban, and urban areas for each route considered.

People at Truck Stops

Typical truck shipments involve stops for meals, fuel, and rest or driver change. During these stops, the public in the vicinity of the truck would be exposed to a stationary source of radiation. A simple, conservative model is used to calculate the collective doses for each route considered.

Crew Members

Collective doses are calculated for truck and aircraft crew members as well as for handlers transferring the shipment from a truck to an aircraft and vice versa for each route considered. No air shipments from or to LANL use passenger aircraft.

Maximally Exposed Individual

A hypothetical MEI is assumed to live 98 feet (30 meters) from the highway, and all trucks are assumed to pass the MEI at a speed of approximately 15 miles per hour (24 kilometers per hour).

F.3.4.2 *Releases from Accidents*

Given a very severe transportation accident, packaging/containers for radioactive/HAZMAT could fail and release their contents. Except for some shipments with very high radiation levels, such as irradiated targets for production of medical isotopes, subsequent dispersion of the material into the atmosphere would be required to produce a significant exposure to members of the public. Either the RADTRAN or ADROIT computer code described in subsection F.4.4 is used to perform the calculations for RAM. The potential acute dose for an individual is expressed in rem, and the potential latent dose for collective population exposure is expressed in person-rem.

The effects of dispersing toxic materials are expressed as the number of persons who could be exposed to life-threatening or injury-producing concentrations. Detonation effects are expressed as the number of persons who could be killed as a result of a fireball or the number of severe burns that could result.

F.4 TRANSPORTATION RISK METHODOLOGY

F.4.1 Introduction and Overview

The analyses of both radioactive and HAZMAT risks are largely accomplished with standard computer codes; the computer code methodology is documented in more detail elsewhere and will not be repeated here. However, the standard parameters (also called the default values) used in the RADTRAN (Neuhauser and Kanipe 1995) code are presented in this section to ensure the repeatability of the results.

The first key parameter, truck and aircraft accident rates, is discussed in subsection F.4.2. State of New Mexico data are used to determine accident rates from the LANL site to I-25, and a standard state-by-state compilation is used for accident rates elsewhere. On-site truck accident rates and accident rates specific to the SST are presented. Aircraft accident rates are also described.

The second key parameter, truck mileage, is evaluated by using the HIGHWAY code (Johnson et al. 1993) as described in subsection F.4.3. The HIGHWAY code also produces population density values (a key parameter) based on 1990 census data as discussed in subsection F.4.3. State-by-state mileages are quantified by HIGHWAY in each of three population density categories: rural, suburban, and urban. The route between I-25 and Pojoaque and between Pojoaque and LANL is

also subdivided by these population density categories.

The RADTRAN or ADROIT codes are used for incident-free dose calculations and for doses from accidents with RAM. An overview of the incident-free methodology and the specific input parameters is presented in subsection F.4.4, as is the accident calculation methodology. Event trees are used for defining HAZMAT and on-site RAM accident scenarios and determining their frequency. The ALOHA™ (NSC 1995) and DEGADIS (Havens and Spicer 1985) codes are used for chlorine accident dispersion calculations.

F.4.2 Accident Rates

Four sets of truck accident rates are used in the analysis: state-specific; route-specific, between I-25 and the LANL site; on-site roads with and without road closure; and the SST.

F.4.2.1 *State-Specific Truck Accident Rates*

Truck accident data for the years 1986, 1987, and 1988, from DOT Office of Motor Carriers, were divided by estimated truck miles data for the same years from DOT Federal Highway Administration (Saricks and Kvitek 1994). The average accident involvement rates for the U.S. and for the State of New Mexico are given in Table F.4.2.1-1. (Note that U.S. 285 to WIPP facility is a federal-aid primary highway.) Saricks and Kvitek point out that the New Mexico urban interstate computed value is more than two standard deviations greater than the national average and indicates decimal place errors in the New Mexico truck mileage data.

F.4.2.2 *Regional Truck Accident Rates*

Truck accident data for U.S. 84/285, NM 502, NM 4, and East Jemez Road were obtained from

TABLE F.4.2.1-1.—Average Truck Accident Rates

HIGHWAY TYPE	ACCIDENT RATE			
	ACCIDENTS PER KILOMETER		ACCIDENTS PER MILE	
	U.S.	NM	U.S.	NM
Urban Interstate	3.58×10^{-7}	9.64×10^{-7}	5.76×10^{-7}	1.55×10^{-6}
Rural Interstate	2.03×10^{-7}	1.92×10^{-7}	3.27×10^{-7}	3.09×10^{-7}
Federal-Aid Primary	3.94×10^{-7}	4.77×10^{-7}	6.34×10^{-7}	7.68×10^{-7}

Source: Saricks and Kvittek 1994.

the State of New Mexico (Fenner 1995 and Fenner 1996) for calendar years 1990 through 1994. Truck mileage data were obtained from the State of New Mexico (Vigil 1996) for the calendar years 1992 through 1994. The traffic count for East Jemez Road is assumed to be 65 percent of that on NM 4 on the basis of a different set of traffic counts (BAA 1993). The data and the computed accident rates are given in Table F.4.2.2-1.

Because no accidents occurred on NM 4, the East Jemez Road rate is used for conservatism. The truck accident rates in Table F.4.2.2-1 for primary highways are lower in low population areas and higher in high population areas than the corresponding values in Table F.4.2.1-1 for federal-aid primary highways in New Mexico. This difference is expected because the rate in Table F.4.2.1-1 is an average of rural, suburban, and urban areas.

F.4.2.3 On-Site Truck Accident Rate

In previous on-site transportation risk analyses at LANL, values from Harwood and Russell (1990) have been used for accident frequency. These values are the most widely used values for truck transport analysis. Their value for two-lane rural roads, 2.19×10^{-6} accidents per mile (1.36×10^{-6} accidents per kilometer) was considered representative for non-rush-hour traffic on the LANL site (Rhyne 1994b). (An urban rate of 8.66×10^{-6} accidents per mile would be appropriate for Diamond Drive and

vicinity.) The representative value used here is a factor of two higher than values for NM 4 and East Jemez Road, but will be conservatively used in the SWEIS for on-site risk analyses. This analysis will also be consistent with the earlier risk analyses that are being incorporated into the SWEIS.

The rates in Tables F.4.2.1-1 and F.4.2.2-1 are averages for trucks traveling in all types of weather, day and night. However, trucking firms that strongly emphasize safety can achieve a factor of 10 reduction in accident rate (Anonymous 1994, Anonymous 1990, Wilson 1990, and OTA 1988). The emphasis on driver safety training and the vehicle maintenance program for RAM shipments on the LANL site are comparable to the safety programs at commercial trucking firms that produced a factor of 10 reduction in accident rate. RAM shipments are made only during daylight, non-rush-hour traffic, and good weather. Drivers work a regular schedule and 8-hour days. These precautions and possibly others lead to an accident rate reduction factor of at least ten for on-site shipments at LANL. As a result, the truck accident rate used in this appendix for on-site transport of RAM and HAZMAT, using DOE trucks and LANL drivers, is 2.19×10^{-7} accidents per mile (1.36×10^{-7} accidents per kilometer). The factor of 10 could also be applied to many off-site shipments. However, because it cannot be applied uniformly, it is conservatively not applied to any off-site shipments.

TABLE F.4.2.2-1.—Truck Accident Rates in the Santa Fe to Los Alamos Area (1990 Through 1994)

ROUTE	MILE MARKER RANGE	TOTAL NUMBER OF ACCIDENTS	AVERAGE TRUCK TRAFFIC (VEHICLES PER DAY)	TRUCK ACCIDENT RATE	
				ACCIDENTS PER KILOMETER	ACCIDENTS PER MILE
Route Through Santa Fe	160.7 to 167.6 ^a	97 ^b	2,104 ^c	2.27×10^{-6}	3.66×10^{-6}
U.S. 84/285	167.6 to 180.2 ^a	17 ^b	1,677 ^c	2.74×10^{-7}	4.41×10^{-7}
NM 502	18.5 to 6.3 ^a	5 ^b	462 ^c	3.02×10^{-7}	4.86×10^{-7}
NM 4	67.8 to 66.5 ^a	0 ^a	520 ^d	6.71×10^{-7}	1.08×10^{-6} ^a
East Jemez Road	NA (distance is 6 miles)	4 ^a	520 ^c	6.71×10^{-7}	1.08×10^{-6}

^a Source: Fenner 1996
^b Source: Fenner 1995
^c Source: Vigil 1996
^d See text
 NA = Not applicable

In conformance with DOT regulations (60 FR [188] 50297), some on-site shipments are made by temporarily closing the affected portions of public roads through the LANL site. Under these conditions, many of the truck accident types can be reduced significantly or even eliminated. According to an analysis of the types of truck accidents and the LANL site administrative controls (Rhyne 1994b), the truck accident rate for closed roads is 1.44×10^{-8} accidents per mile (8.95×10^{-9} accidents per kilometer). This procedure has been used and defended previously (Rhyne 1985) and has compared well with data (Green et al. 1996). The on-site truck accident rates are given in Table F.4.2.3-1.

F.4.2.4 Safe Secure Tractor Trailer Accident Rate

The SST accident record is excellent. In the 9-year period between 1988 and 1996, the overall accident rate was 7.7×10^{-8} accidents per mile. The number of SST accidents is too

small to support allocating this overall rate among the various types of routes used in the accident analyses (urban interstate, rural interstate, other urban, and other rural). Therefore, data for the relative rates of accidents on these route types for five-axle vans in the appropriate weight range (Phillips et al. 1994) was used to allocate SST rates among these route types. The resulting SST rate for each

TABLE F.4.2.3-1.—Truck Accident Rates at the LANL Site

TRANSPORT DESCRIPTION	ACCIDENT RATE	
	ACCIDENTS PER KILOMETER	ACCIDENTS PER MILE
Off-Site Trucks at LANL Site ^a	1.36×10^{-6}	2.19×10^{-6}
DOE Trucks with LANL Drivers ^b	1.36×10^{-7}	2.19×10^{-7}
Trucks with Road Closure ^b	8.95×10^{-9}	1.44×10^{-8}

^a Source: Harwood and Russell 1990
^b Source: Rhyne 1994b

route type is presented in Table F.4.2.4–1. The “other rural” value in Table F.4.2.4–1 corresponds to the “DOE trucks with LANL drivers” value in Table F.4.2.3–1. The first two values of Table F.4.2.4–1 can be compared with the first two values of Table F.4.2.1–1 to see the effect of the strong safety culture described in subsection F.4.2.3.

F.4.2.5 Aircraft Accident Rate

Air transport to and from LANL is assumed to be by commercial air-cargo carriers such as Federal Express to and from the Albuquerque International Airport (transport between this airport and LANL is by truck or van). Shipments are picked up in the carrier’s van and taken to an airport, flown to the destination city, and taken to the final destination by the carrier’s van. Commercial air-cargo carriers are categorized as large certified air carriers and are assumed to fall in the subcategory of “large nonscheduled service” for which the 1992 accident rate was 7.9×10^{-9} accidents per mile (DOT 1992). The accident rate has been at or below this value for 4 out of the 5 years between 1988 and 1992. The accident rate is about twice that for large, scheduled service.

Accidents involving air shipments were screened relative to truck shipments. The aircraft accident rate per mile is two orders of

magnitude less than the truck accident rate per mile for similar shipments. The probability of a high severity accident is higher for aircraft, but not much higher (section F.4.4.3).

F.4.3 Route, Mileage, and Population Density Determination

The scope of the SWEIS calls for analysis of LANL shipments of RAM and HAZMAT to and from other DOE sites as well as to and from numerous educational or commercial sites. The calculation approach is to determine the RAM and HAZMAT shipments by alternative (section F.5). The routes between DOE sites are then determined for the shipments unique to those sites, and routes between geographical areas of the U.S. are determined for all other shipments. Five geographical areas are defined for RAM shipments: northeast, southeast, northwest, southwest, and New Mexico. The cities selected as representative of each area are Concord, Massachusetts; Aiken, South Carolina; Richland, Washington; Berkeley, California; and Albuquerque, New Mexico. The cities were chosen as conservatively representative on the basis of the number of shipments to various locations in the geographic area in the 1990 through 1994 baseline (see subsection F.5.2). In the northwest, southeast, and southwest, cities near DOE sites were chosen because they appeared to be reasonable choices for general shipments to and from the region. The routes for each shipment were then used to estimate shipment mileages (see Table F.6.1–1 for distances between LANL and the representative cities for RAM and HAZMAT shipments).

The representative truck routes were determined by using the routing code HIGHWAY, Version 3.3 (Johnson et al. 1993), available to the public and DOE users through the TRANSNET computer system at Sandia National Laboratories (SNL). The HIGHWAY code

TABLE F.4.2.4–1.—Safe Secure Trailer Accident Rates

HIGHWAY TYPE	ACCIDENT RATE	
	ACCIDENTS PER KILOMETER	ACCIDENTS PER MILE
Urban Interstate	3.01×10^{-8}	4.85×10^{-8}
Rural Interstate	4.45×10^{-8}	7.16×10^{-8}
Other Urban	1.87×10^{-7}	3.01×10^{-7}
Other Rural	1.83×10^{-7}	2.95×10^{-7}

Source: Phillips et al. 1994

contains a database of at least 240,000 miles (386,000 kilometers) of roads.

The population densities along a route are derived from 1990 census data from the U.S. Bureau of the Census. Rural, suburban, and urban areas are characterized according to the following breakdown: rural population densities range from 0 to 139 persons per square mile (0 to 54 persons per square kilometer); the suburban range is 140 to 3,326 persons per square mile (55 to 1,284 persons per square kilometer); and urban areas encompass all population densities greater than 3,326 persons per square mile (1,284 persons per square kilometer).

All routes for shipment of radioactive or HAZMAT into or out of LANL are conservatively assumed to pass through Santa Fe for the baseline analysis (the comparative analysis of the proposed bypass route is discussed in section F.7 of this appendix). The route between the LANL site and I-25 in Santa Fe is subdivided into two segments. The corresponding HIGHWAY results are shown in Table F.4.3-1. Similar information was generated from I-25 in Santa Fe to each origin or destination on a state-by-state basis.

Cargo air shipments are also made to and from the LANL site. Air shipments arrive at the Albuquerque Airport and are transported by truck to the LANL site or vice versa. Air shipments are included in incident-free impact

analyses, but screened from accident analyses, as discussed in section F.4.2.5.

F.4.4 RADTRAN and ADROIT Analyses for Radioactive Materials

Two of the four risk measures described in section F.3 are modeled by RADTRAN (Neuhauser and Kanipe 1995) (refer to Figure F.3-1). The RADTRAN code is designed to produce conservative estimates of the radiological dose to workers and the public during incident-free transportation and the radiological risks from potential accidents.

The RADTRAN code was originally developed in 1977 in conjunction with the preparation of NUREG-0170, *Final Environmental Statement on the Transportation of RAM by Air and Other Modes* (NRC 1977). Subsequent versions have expanded and refined the analytical capability of the code; the current version is RADTRAN 4 (Neuhauser and Kanipe 1995). RADTRAN is maintained, updated, and improved on a continuing basis by SNL for DOE. RADTRAN is available to the public as well as to DOE users through the TRANSNET computer system at SNL. RADTRAN is widely accepted and used both in the U.S. and internationally.

The ADROIT code was developed in the 1992 through 1994 time frame to replicate the RADTRAN incident-free and accident estimates specific to transport in an SST. The

TABLE F.4.3-1.—Route Segment Information from I-25 to LANL

ROUTE SEGMENT	TOTAL DISTANCE		AVERAGE POPULATION DENSITY (PERSONS/km ²)			DISTANCE BREAKDOWN (km)		
	km	MILES	RURAL	SUBURBAN	URBAN	RURAL	SUBURBAN	URBAN
I-25 Exit 282 to U.S. 285/84 Junction with NM 502	32.2	20.0	11	625	2,228	24.0	6.3	1.9
Junction of NM 502 and U.S. 285/84 to NM 4 and Junction of East Jemez Road and Diamond Drive	30.6	19.0	14	312	0	28.5	2.1	0.0

code was developed from first principles; and although the end results are very similar to RADTRAN, the specific models may vary. Significant differences include the use of an event tree rather than an accident severity matrix (subsection F.4.4.2). As used in this analysis, the codes can be considered equivalent.

F.4.4.1 *Incident-Free Risk Parameters*

The most important parameter for evaluation of incident-free risk is the package exterior radiation level. The transport index (TI) is used in RADTRAN to characterize the exterior radiation field. The TI is defined in 49 CFR 173.403(bb) as “the exposure rate in millirems per hour at a distance of 1 meter from the surface of the package,” and DOT regulations limit the value of TI to 10 or less for general commerce shipments. The TIs for the LANL baseline shipments discussed in section F.5.0 are based on measurements. The average truck shipment TI is less than 2, and the average air shipment TI is approximately 0.1. During the data-gathering process for the SWEIS alternatives, LANL transportation specialists were asked to place a reasonable upper bound on the average for the entire shipment type being discussed. (An average is appropriate for incident-free risk in contrast to accident risk.) When there is little or no experience with a particular shipment type, the usual procedure is to use the legal limit as a conservative value.

The alternative-specific parameters are given in section F.5.0, and those generic to all alternatives are given in Table F.4.4.1–1. Two exceptions to Table F.4.4.1–1 are used: a value of 1.0 is used for the urban city street fraction in Santa Fe, and the fractions of rural and suburban travel on freeways are 0.347 between I–25 and Pojoaque and 0.525 between Pojoaque and LANL.

F.4.4.2 *Accident Severity Categories*

Accident forces include fire, crush, impact, and puncture, and many accidents involve a combination of thermal and mechanical forces. The severity of accidents is categorized in RADTRAN by up to 20 categories for the magnitudes of accident forces and the associated probabilities. The accident severity category approach seeks to relate the magnitude of an accident force with mode of package response (e.g., small structural strains produce no release; larger strains produce loss of containment function and gross rupture). Ideally, such an analysis is done for each type of package; however, as pointed out earlier, this level of detail is impractical for the SWEIS. Most DOE environmental impact statements (EISs) rely on the accident severity categorization scheme described in an NRC report commonly referred to as NUREG–0170 (NRC 1977). NRC divided the spectrum of accident severities into eight categories that are independent of a specific accident sequence. The eight categories are designed to take into account all credible accidents, including accidents with low probability but high consequence and those with high probability but low consequence. The probabilities that correspond to the accident forces characterizing a particular package response are based on analyses by Dennis et al. (1978) or Clarke et al. (1976). The NUREG–0170 accident severity categories and associated probabilities are given in Table F.4.4.2–1.

Category I accidents are the least severe and the most frequent. Category I is considered to include all those accidents less severe than the normal conditions of transport in which Type A packages are shown by tests to be capable of retaining all their contents (section F.2.0). Category II is considered to include accidents more severe than Category I but less severe than the accident conditions in which Type B packages are shown by tests to be capable of retaining all their contents. The percentage of

TABLE F.4.4.1-1.—Parameter Values for Incident-Free Risk Quantification

PARAMETER DESCRIPTION	TRACTOR-TRAILER	CARGO AIR	DELIVERY VAN
Speed in Rural Area, kilometers per hour	88.49	691.90	88.49
Speed in Suburban Area, kilometers per hour	40.25	691.90	56.34
Speed in Urban Area, kilometers per hour	24.16	691.90	24.16
Number of Crew	2	3	1
Average Distance from Radiation Source to Crew, meters	3.10	6.10	2.13
Number of Handlings per Shipment	0	4	6
Time Spent at Rest Stops, hours per kilometer	0.011	0.0016	0.0004
Minimum Rest Stop Time, hour	0.0	1.0	0.15
Number of Persons Exposed During Stops	50	10	100
Average Exposure Distance When Stopped, meters	20	50	10
Storage Time per Shipment, hour	0	0	10
Number of Persons Exposed During Storage	100	100	100
Average Exposure Distance When Stopped, meters	100	100	100
Number of Persons per Vehicle Sharing the Route	2	0	2
Fraction of Urban Travel During Rush Hour	0.08	0	0.08
Fraction of Urban Travel on City Streets	0.05	0	0.65
Fraction of Rural and Suburban Travel on Freeways	0.85	0	0.25
Ratio of Urban Pedestrian to Residential Population Densities	6	0	6
Rural Building Shielding Factor	1	0	1
Suburban Building Shielding Factor	0.87	0	0.87
Urban Building Shielding Factor	0.018	0	0.018

Source: Neuhauser and Kanipe 1992

TABLE F.4.4.2–1.—Fractional Occurrences for Truck Accidents by Severity Category and Population Density Zone

SEVERITY CATEGORY	FRACTIONAL OCCURRENCE	FRACTIONAL OCCURRENCE BY POPULATION DENSITY ZONE		
		RURAL	SUBURBAN	URBAN
I	0.55	0.1	0.1	0.8
II	0.36	0.1	0.1	0.8
III	0.07	0.3	0.4	0.3
IV	0.016	0.3	0.4	0.3
V	0.0028	0.5	0.3	0.2
VI	0.0011	0.7	0.2	0.1
VII	8.5×10^{-5}	0.8	0.1	0.1
VIII	1.5×10^{-5}	0.9	0.05	0.05

Source: NRC 1977

truck accidents less severe than Type B test conditions is 91 percent according to the 1977 NRC report. A 1987 NRC study (LLNL 1987) estimated that 99.4 percent of the truck accidents would not cause a release from a Type B package. The more conservative results from the older NRC study are used in the SWEIS transportation risk analyses. Packages for plutonium are required to have both inner and outer containment vessels (10 CFR 71.63). Tests with these packages produced no structural damage to the inner containment vessel after impacts with unyielding targets at speeds typical of a Category V impact accident. Several containment vessels exhibited minor damage for Category VI impacts, but no verified release occurred (NRC 1977).

F.4.4.3 Package Release Fractions

The release fraction is defined as the fraction of the RAM in a package that could be released from that package during an accident of a certain severity. Release fractions take into account all mechanisms necessary to create a release of RAM from a damaged package to the environment. Release fractions vary according to the package type. Type B packaging are designed to withstand the forces of severe

accidents and, therefore, have smaller release fractions than Type A packaging. Plutonium packages are designed to even higher standards.

In a given accident involving a number of packages transported together, some of the packages could release part of their contents while others could have no release at all. The approach taken in an accident severity categorization scheme is to derive an estimate for the average release fraction for each severity category to support the assumption that all such packages in a shipment respond in the same way.

Release fractions for accidents of each severity category are given in Table F.4.4.3–1 for the package types considered in this appendix.

Note that the release fraction levels out at 100 percent for highest severity accidents. Since 82 percent of aircraft accidents are level III or less, as compared to 98 percent of truck accidents, the probability of a large release due to aircraft accidents is not much higher than that for truck accidents. For this reason, as well as the much higher frequency of truck accidents, aircraft accidents are screened from further analysis (Rhyne 1997).

TABLE F.4.4.3-1.—Estimated Release Fractions for Shipping Packaging Under Various Accident Severity Categories

SEVERITY CATEGORY	ESTIMATED RELEASE FRACTION	
	TYPE A	TYPE B
I	0	0
II	0.01	0
III	0.1	0.01
IV	1.0	0.1
V	1.0	1.0
VI	1.0	1.0
VII	1.0	1.0
VIII	1.0	1.0

Source: NRC 1977

F.4.4.4 Respirable Fractions

Subsequent to release, dispersion of the material into the atmosphere as an aerosol and, in most cases of interest, inhalation into the respiratory tract (respirable aerosols only) would be required to produce a significant exposure to members of the public. Therefore, in addition to determining the respirable fractions, the portion of that release which is respirable is also determined for risk analysis. Most solid materials are relatively nondispersible. Conversely, gaseous materials are easily dispersed. Liquid dispersibility depends on the liquid volatility. The aerosolization and respirable fractions depend on the physical form of the material.

The bounding off-site shipments described in subsection F.6.5.1 are plutonium powders. (The specific application of this methodology to the bounding shipments is also discussed in section F.6.5.1.) Generally the powder is pressed, reducing its dispersibility, and enclosed within four layers of metal containers: two associated with the plutonium packaging and two

associated with handling outside the packaging. Should these four layers of containment fail in an impact accident, the mechanisms for converting the powder to a respirable aerosol would be the impact force itself and the release of gases.

Radioactive decay and solar insulation produce heat that causes gas within containers (including chemically inert gases, such as argon) to expand, thus raising the gas pressure inside the packaging. In addition to producing heat, radioactive decay produces helium, which further increases pressure. The average atmospheric pressure at LANL is 11.3 pounds per square inch absolute (psia), in contrast to 14.7 at sea level. The total pressure difference between the inner powder container and the environment from these factors can be as high as 30.1 psig. Tests with air injected into the bottom of a powder bed in an open-top container produced respirable fractions of 3×10^{-5} , 6.7×10^{-4} , and 6.1×10^{-4} for pressures of 9, 17.5, and 24.5 psig, respectively (DOE 1994b). The highest of the three values was used in this appendix. The fraction of powder aerosolized by depressurization is about a factor of 20 higher than the fraction aerosolized by impact forces (DOE 1994b) and the latter can be ignored in comparison to the former.

The use of the value of 6.7×10^{-4} for the respirable fraction of a release in this appendix is conservative since the four containment vessels would not be expected to completely open up, even in a severe impact accident.

Given an accident involving fire, the release mechanism would also be rapid depressurization since the packaging would contain no combustible material. Once a pathway from the powder cans to the environment is established, some additional powder may be aerosolized by updrafts from the fire. Review of DOE Handbook 3010-94 (DOE 1994b) shows that the depressurization effect is about 400 times larger than the updraft

effect and the latter can be ignored in comparison to the former.

Exposure of a plutonium package to a 1,475°F fire for 30 minutes would produce a gas pressure of 64.5 psig in a container that has a rupture pressure of 123 psig (Barklay 1983). Longer fires would produce higher gas pressures and lower rupture pressures; therefore, the gas pressure at rupture would be no higher than 123 psig.

Table 4–12 in DOE Handbook 3010-94 (DOE 1994b) presents respirable fraction estimates from the aforementioned pressurized powder release tests for pressures of 9, 18, 24.5, 250, and 500 psig. For 250 psig, the maximum respirable fraction of a release is 2.5×10^{-2} . This value is judged to be conservative for the present case, because the test pressure was a factor of 2 higher than the expected package burst pressure and the tests involved blowing powder out of an open-topped container with a burst of air injected at the bottom of the powder bed.

The impact and fire values are combined for the RADTRAN severity categorization scheme by considering that fires occur in 1.6 percent of all truck accidents. The weighted value of the respirable fraction is then $(0.984)(6.7 \times 10^{-4}) + (0.016)(2.5 \times 10^{-2}) = 1.06 \times 10^{-3}$ for an open-top container. Table F.4.4.4–1 shows the results of combining the open-top container value of 1×10^{-3} with the Type B package release factors of Table F.4.4.3–1. The values for WIPP packaging, obtained by a similar analysis (DOE 1990), are also shown in Table F.4.4.4–1.

F.4.4.5 Health Risk Conversion Factors

The risk from ionizing radiation consists mostly of some number of excess latent cancer fatalities (LCFs). These are cancers resulting from, and that develop well after, the exposure to ionizing radiation. These represent an increase in the number of fatal cancers that occur from other causes. The excess LCF is the product of the dose and the risk conversion factor. The reader should recognize that these estimates are

TABLE F.4.4.4–1.—Estimated Respirable Release Fractions for Shipping Packaging Under Various Accident Severity Categories

SEVERITY CATEGORY	ESTIMATED RESPIRABLE RELEASE FRACTION		
	TYPE B ^a	TRUPACT-II ^b	NUPAC 72B ^b
I	0	0	0
II	0	0	0
III	1×10^{-5}	8×10^{-9}	6×10^{-9}
IV	1×10^{-4}	2×10^{-7}	2×10^{-7}
V	1×10^{-3}	8×10^{-5}	1×10^{-4}
VI	1×10^{-3}	2×10^{-4}	1×10^{-4}
VII	1×10^{-3}	2×10^{-4}	2×10^{-4}
VIII	1×10^{-3}	2×10^{-4}	2×10^{-4}

^a For package contents of loose powder

^b Source: DOE 1990

intended to provide a conservative measure of the potential impacts to be used in the decision-making process and do not necessarily portray an accurate representation of actual anticipated fatalities. In other words, one could expect that the stated impacts form an upper bound and that actual consequences could be less, but probably would not be worse. Refer to appendix D, section D.1 for further discussion of the determination and application of risk factors for LCFs.

The health risk conversion factors used throughout this appendix to estimate the number of expected cancer-caused fatalities due to radiological exposures are 5.0×10^{-4} cases of expected excess LCFs per person-rem for members of the public, and 4.0×10^{-4} cases per person-rem for workers (ICRP 1991).

F.4.5 Event Tree Analysis

Event trees are used for the analyses of off-site accidents involving HAZMAT transportation and on-site accidents involving RAM transportation.

An event tree is a graphical model for identifying and evaluating potential outcomes from a specific initiating event. The event tree depicts the chronological sequence of events (accident scenario) that could result from the initiating event. The identification of accident scenarios are the first of two key results from the event tree analysis; quantification of the scenario frequencies from the event tree is the second key result.

Figure F.4.5–1 is a graphical representation of five accident scenarios. The frequency of an accident producing a puncture force is designated as the parameter A, which is inserted on the tree as illustrated in Figure F.4.5–1. The conditional probability that puncture force causes package failure designated as the parameter B. Because B is the conditional probability that puncture force causes package

failure, then $1-B$ is the conditional probability that puncture force does not cause package failure. The parameter C designates the conditional probability that a fire occurs, and the parameter D is the conditional probability that the fire duration is sufficient to cause package failure. The frequency of a particular scenario (e.g., puncture failure without fire, which is designated as F_2), is evaluated by multiplying the initiating event frequency and the individual probabilities, [e.g., $F_2 = A \times B \times (1 - C)$].

The parameter A is the product of the accident rate from section F.4.2.3 and the fraction of the accidents producing puncture force. The latter is taken from Dennis et al or Clarke et al., as appropriate. The parameter C and the probabilistic force magnitude distributions needed to evaluate parameters B and D are from the same two references.

Event trees similar to Figure F.4.5–1 are used for impact, crush, puncture, and fire without mechanical forces. This approach is conservative because the failures from other mechanical forces are not excluded for failure from the specific mechanical force. Clearly, the package can fail only once and the mechanical failures are triple counted. The error is generally less than a few percent, but the event trees are greatly simplified. The simple form for each force results from the assumption that all failures for a single accident force can be aggregated for frequency analysis. In frequency analysis, one package failure mode for a particular transportation accident force usually dominates the others. Event trees for fixed facilities are generally more complicated than transportation event trees because there are usually more opportunities for safety systems or operator action to mitigate the accident initiator.

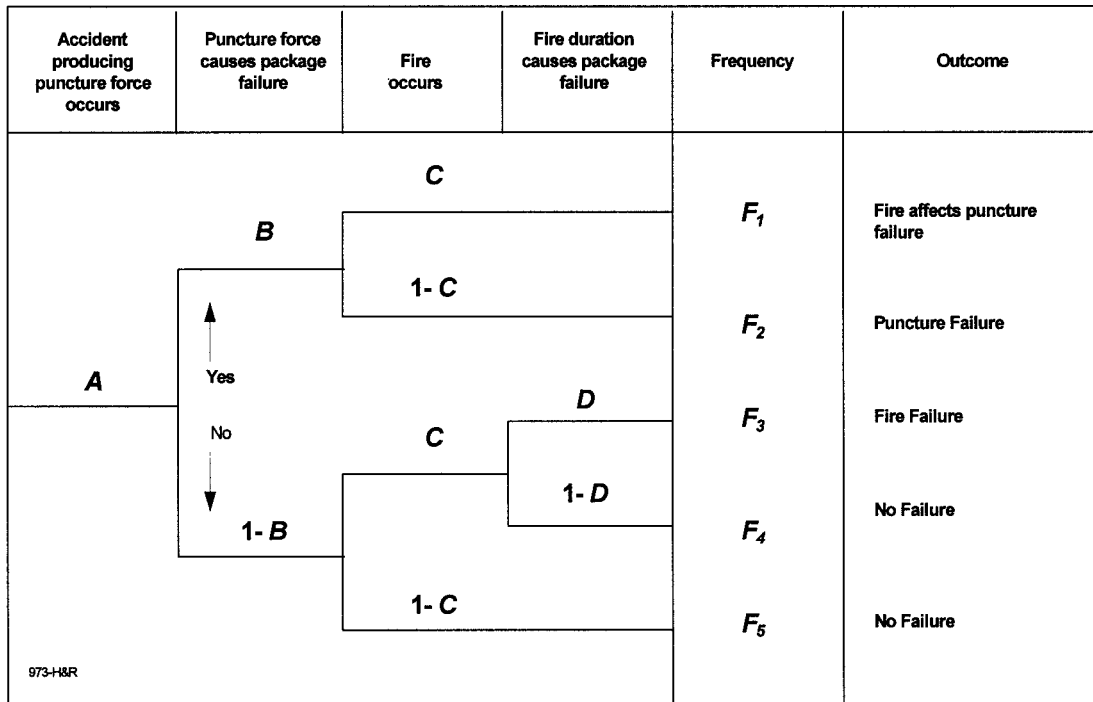

FIGURE F.4.5-1.—Event Tree Analysis of Puncture Accidents.

F.5 DETERMINATION OF SHIPMENTS BY ALTERNATIVE

F.5.1 Introduction

The determination of shipments of RAM and HAZMAT proceeded in three steps. First, historical databases were examined to get an overview, focus the subsequent data gathering to the most important risk contributors, and provide an accuracy check for the data-gathering process.

Data gathering, the second step, consisted of both interviews with cognizant persons and reviews of additional databases. The data-gathering process for RAM involved different databases, interviewees, and interviewers than the data-gathering process for HAZMAT.

The last step was the tabulation of results for each SWEIS alternative.

F.5.2 Baseline Shipments

DOE tracks unclassified shipments in a database called the Shipment Mobility/Accountability Collection (SMAC). The tracking is based on shipping invoices paid by DOE and its contractors. Data on approximately 5,000 RAM and HAZMAT shipments to or from LANL were obtained from the SMAC for fiscal years 1990 through 1994. The shipments were first aggregated into 81 commodity groups, e.g., paint. The least HAZMAT were determined on the basis of the material maximum shipment weight compared with regulatory reporting thresholds in 40 CFR 302, Table 302.4, or 40 CFR 355, appendices A and B. The material was screened from further consideration if the maximum shipping amount was less than the threshold.

The remaining materials were grouped into four categories: radioactive, toxic, flammable, or explosive materials. A bounding material was picked as the most hazardous for each of these four groups on the basis of the toxicity of

materials shipped in large amounts to or from LANL. The results are shown in Table F.5.2-1. Also shown in Table F.5.2-1 are the numbers of large and small shipments over the 5-year period. A large shipment is one that is greater than 10 percent of the maximum shipment quantity.

The materials screened from further consideration because of their low hazard are not listed in Table F.5.2-1. Some classified shipments, e.g., SST shipments, are also not included in Table F.5.2-1, since an invoice is not submitted for payment, however, classified shipments are considered in the risk analyses.

A recent annual shipment summary prepared by LANL is shown in Table F.5.2-2. Off-site shipments of RAM and HAZMAT total 3,526 per year in contrast to the SMAC results (Table F.5.2-1) of about 1,000 per year (when the screened shipments are considered). The large difference is due to the classified shipments mentioned previously and to other shipments for which LANL is not billed explicitly for transportation (e.g., contaminated-laundry shipments). Table F.5.2-2 was used to determine the number of HAZMAT shipments used in subsection F.5.3, and Table F.5.2-1 was used to help characterize those shipments

F.5.3 Shipments For SWEIS Alternatives

The determination of shipments by SWEIS alternative focused on ensuring that shipments were identified of both RAM and HAZMAT that could contribute significantly to accident risk. For example, bulk gas shipments were of special interest.

The RAM shipment characteristics were determined by interviewing cognizant LANL staff. Historical shipment data, on-site and off-site, were used to help ensure completeness. On-site shipments of SNM at the gram level were not individually accounted for because

their contribution to risk would be minor; however, shipment projections were conservatively high to ensure that the transportation risks were bounded in this analysis. The off-site and on-site RAM shipments for each LANL SWEIS alternative are listed in Tables F.5.3-1 and F.5.3-2, respectively. The number of shipments projected is higher than those reflected in Table F.5.2-2 for a variety of reasons, including: the conservatism applied to shipment projections, the fact that several activities at LANL have been operating below planned levels, and the fact that some programs at LANL are increasing activity levels over recent levels due to DOE decisions made prior to this SWEIS (e.g., stockpile stewardship in the absence of underground testing, demonstration of accelerator production of tritium, and surveillance of stored materials).

The conservatism applied to the shipments is reflected in two ways. First, the number of shipments per year reflected in the table is typically at the high end of a range; this is done to ensure that impacts associated with total mileage are not underestimated. Second, the number of packages in a shipment is at the high end of a range; this is done to ensure that impacts associated with the shipment quantities (e.g., accidents that release cargo and worker and public exposures under no-incident conditions) are not underestimated. These shipments should not be used to estimate material flows/balances because the combination of bounding shipment numbers and bounding packages per shipment would yield overly conservative material flows. For those interested in such balances, the No Action Alternative would result in an average annual plutonium inventory increase of about 130 kilograms. The other alternatives would have slightly different average annual flows, but the inventory growth over the next 10 years can be accommodated in storage facilities, once the NMSF at TA-55 is operational. The enriched uranium inventory at LANL may actually

TABLE F.5.2-1.—Summary of Radioactive and Hazardous Material Bounding Off-Site Shipments to and from LANL, 1990 Through 1994

TRANSPORT MODE	MATERIAL CATEGORY	BOUNDING MATERIAL	MAXIMUM SHIPPING QUANTITY	NUMBER OF SMALL ^a SHIPMENTS	NUMBER OF LARGE ^b SHIPMENTS
Truck	Flammable	Hydrogen	50,000 ft ³	320	17
Truck	Toxic	Chlorine	2,000 lb	136	22
Truck	Radiological ^c	Tritium	29,160 Ci	406	11
Truck	Explosive	HMX	13,801 lb	102	24
Air	Toxic	Chlorine	7 lb	160	15
Air	Explosive	HMX	195 lb	21	80
Air	Radiological	Tritium	970,000 Ci	1,185	1

HMX = octahydro-1,3,5,7-tetranitro-1,3,5,7-tetrazocine

^a About 2,500 shipments screened because of low material toxicity

^b Large shipments are greater than 10% of the maximum shipping quantity

^c SST trailer shipments not included

TABLE F.5.2-2.—Annual LANL On-Site and Off-Site Shipments

TYPE	NONHAZARDOUS	HAZARDOUS (NONRADIOACTIVE)	RADIOACTIVE
Off-Site	327,939	2,592	934
On-Site	Not available	7,560	1,187

Source: Villa 1996

TABLE F.5.3-1.—Off-Site Shipments of Radioactive Materials

PROGRAM/MATERIAL	FORM	ORIGIN	DESTINATION	PACKAGING AND AMOUNT ^a	PACKAGES PER SHIPMENT	SHIPMENTS PER YEAR BY ALTERNATIVE				COMMENT
						NO ACTION	EXPANDED	REDUCED	GREENER	
Stabilization Project 345 for Plutonium-239	Salt	RFETS ^c	TA-55	500 g plutonium-239 in Type B	40 6M	1 (total) ^b	8 (total) ^b	1 (total) ^b	8 (total) ^b	SST
	Oxide	TA-55	RFETS ^c	As above	As above	1 (total) ^b	8 (total) ^b	1 (total) ^b	8 (total) ^b	SST
Pit Fabrication, P362	Plutonium Metal	Pantex	TA-55	FL	10	0	12	0	0	SST
	Plutonium Metal	TA-55	Pantex	FL	10	5	8	5	5	SST
Pit Surveillance, P301	Plutonium Metal	Pantex	TA-55	FL	4 to 6	5	10	5	10	SST
	Plutonium Metal	Pantex	TA-55	FL	10	1	1	1	1	SST
Pit Disassembly ^d	Plutonium Metal	RFETS	TA-55	FL	10	1	1	1	1	SST
	Plutonium Metal	SRS	TA-55	FL	2	1	1	1	1	SST
	Plutonium Metal	LLNL	TA-55	FL	2	1	1	1	1	SST
	Plutonium Metal	SRS	TA-55	FL	19	2	2	2	2	SST
Pit Disassembly	Enriched Uranium Metal	CMR and TA-55	Oak Ridge	Type B or equivalent	22	7	20	7	7	SST
MOX Fuel (Parallex)	Oxide in welded rods	TA-55	Canada	0.3 kg plutonium (weapons grade) 1.2-1.8 kg MOX Type B	1	2	2	2	2	SST
	RTG	Pantex	TA-55	500 g plutonium-238 Type B	10	1	1	1	1	SST
Plutonium-238 Operations	Oxide Powder	TA-55	SRS	500 g 83% plutonium-238 Type B	10	2	2	1	2	SST
	Oxide Powder	SRS	TA-55	500 g plutonium-238 Type B	15 to 22	4	4	1	4	SST
NASA Plutonium-238 Heat Source	Encapsulated powder	TA-55	Mound	1,800 g Type B	2	10	12	8	12	SST
Actinide Processing & Recovery/ Plutonium (weapons grade)	Plutonium Metal	Pantex	TA-55	FL	2 to 8	5	5	0	0	SST
	Plutonium Metal	RFETS	TA-55	FL	2 to 8	5	5	0	0	SST
	Plutonium Metal	SRS	TA-55	FL	2 to 4	1	2	0	0	SST
	Plutonium Metal	LLNL	TA-55	FL	2 to 4	1	2	0	0	SST
As Above/Uranium	Metal	Oak Ridge	TA-55	Type B	7 to 10	24	60	24	24	SST

TABLE F.5.3-1.—Off-Site Shipments of Radioactive Materials-Continued

PROGRAM/MATERIAL	FORM	ORIGIN	DESTINATION	PACKAGING AND AMOUNT ^a	PACKAGES PER SHIPMENT	SHIPMENTS PER YEAR BY ALTERNATIVE			COMMENT
						NO ACTION	EXPANDED	REDUCED	
Plutonium (weapons grade) Standards	Oxide	TA-55	Uniform U.S.	4 kg in 9,968 Type B	5	5	5	5	SST
	Oxide	Uniform U.S.	TA-55	4 kg in 9,968 Type B	5	5	5	5	SST
	Oxide	TA-55	Uniform U.S.	395 g Type B	5	24	24	24	
	Oxide	Uniform U.S.	TA-55	395 g Type B	5	24	24	24	
Americium-241 Standards Sales	Oxide	TA-55	Houston, TX	28 g in 6M	1	2	1	2	
	Oxide	TA-55	England	28 g in 6M	4	3	3	6	
	Oxide	TA-55	NY & CA	13 g in 6M	1	2	2	2	
Material Disposition	Plutonium Metal	Pantex	TA-55	FL	3 to 19	12	0	0	SST
	Plutonium Metal	RFETS	TA-55	FL	14	1 (total) ^b	1 (total) ^b	1 (total) ^b	SST
Bulk Tritium	Solid storage	Mound	TA-16/21	120 g tritium in UC-609	1	4 (total) ^b	4 (total) ^b	4 (total) ^b	SST
	Metal powder	Mound	TA-55	<250 g plutonium in Type B	2	1 (total) ^b	1 (total) ^b	1 (total) ^b	SST
Subcritical Test Program	Test assembly	TA-55	NTS	FL	1	4	4	4	SST
	Secondaries	Oak Ridge	CMR	CSA	1	10	1	1	SST
Weapons System Evaluation Program Number 301	Metal	CMR	SNL	30 g HEU/target 12 targets/6M	2	45	2	45	
	Powder	CMR	Oak Ridge	<300 g HEU in Type A	10	5	3	5	SST, yearly values for 1998+2002 only
Secondaries Design Eval	Secondaries	Pantex	CMR	Type B	1	1	1	1	SST
	Secondaries	TA-18	Oak Ridge	Type B	--	1	1	1	SST
	Secondaries	Pantex	TA-18	Type B	3 to 4	1 (total) ^b	2 (total) ^b	1 (total) ^b	Initial receipt at TA-55 in SST, then to TA-18 for storage.
Sealed Sources	Double encapsulated	Uniform U.S.	TA-18	300 Ci iridium-92 shielded cask	1	3 (total) ^b	3 (total) ^b	3 (total) ^b	
	Double encapsulated	Uniform U.S.	TA-18	few mCi	1	20	20	20	
Plutonium Objects	Metal	See comment	TA-18	5.85 x 10 ³ Ci plutonium-239 1.36 x 10 ³ Ci plutonium-240 in 50-gal. 6M	2	2 (total) ^b	2 (total) ^b	2 (total) ^b	Assume 1 from INEL, 1 from RF, and 1 (Expanded Operations) from Pantex.

TABLE F.5.3-1.—Off-Site Shipments of Radioactive Materials-Continued

PROGRAM/MATERIAL	FORM	ORIGIN	DESTINATION	PACKAGING AND AMOUNT ^a	PACKAGES PER SHIPMENT	SHIPMENTS PER YEAR BY ALTERNATIVE			COMMENT
						NO ACTION	EXPANDED	REDUCED	
Unirradiated Low Enriched Uranium Fuel	Oxide in Al rods	See comment	TA-18	8.4 x 10 ⁻³ Ci uranium-235 2.9 x 10 ⁻³ Ci uranium-238 in 50-gal. 6M	10	3 (total) ^b	6 (total) ^b	3 (total) ^b	Assume 1 from Hanford, 2 from SRS; times 2 for Expanded Operations.
								3 (total) ^b	
Irradiated Highly Enriched Uranium Fuel	Metal or ceramic composite	Oak Ridge	TA-18	2.2 x 10 ⁻² Ci uranium-235 2.6 x 10 ⁻⁴ Ci uranium-238 in 50-gal. 6M	20	4 (total) ^b	8 (total) ^b	4 (total) ^b	SST
Highly Enriched Uranium	Metal or ceramic composite	TA-18	Oak Ridge	2.2 x 10 ⁻² Ci uranium-235 2.6 x 10 ⁻⁴ Ci uranium-238 in 50-gal. 6M	20	1	1	1	
Feedstock Depleted Uranium	Bulk metal	SRS	Sigma	2,000 kg uranium total in STCs	25	45	232	45	
Depleted Uranium	Bulk metal	Oak Ridge	Sigma	500 kg uranium total in STCs	20	45	171	45	
Depleted Uranium Parts	Bulk metal	Oak Ridge	Sigma	75 kg uranium total in STCs	10	60	165	60	
Depleted Uranium Samples	Turnings	Sigma	Oak Ridge	75 kg uranium total in STCs	10	60	165	60	
Highly Enriched Uranium (research and manufacturing technologies) ^c	Bulk metal	Concord, MA	Sigma	75 kg uranium total in STCs	10	85	300	85	
Thorium-232 Oxide	Powder	Sigma	Oak Ridge	1,000 kg thorium-232 total in 55-gal. shielded drums	1	1	1	1	

TABLE F.5.3-1.—Off-Site Shipments of Radioactive Materials-Continued

PROGRAM/MATERIAL	FORM	ORIGIN	DESTINATION	PACKAGING AND AMOUNT ^a	PACKAGES PER SHIPMENT	SHIPMENTS PER YEAR BY ALTERNATIVE			COMMENT
						NO ACTION	EXPANDED	REDUCED GREENER	
Bulk Tritium	Gas or solid storage	SRS	TA-16/21	120 g tritium in UC609	up to 10	10	20	10	10
	Gas or solid storage	TA-16/21	SRS	120 g tritium in UC609	up to 5	2	4	2	2
	Gas or solid storage	SRS	TA-16/21	120 g tritium in H616-2	up to 10	10	20	10	10
	Gas or solid storage	TA-16/21	Rochester, NY	≤ 1,000 Ci in Type A	up to 10	50	100	50	50
	Gas or solid storage	Rochester, NY	TA-16/21	≤ 1,000 Ci in Type A	up to 10	100	100	100	100
Tritiated Water Bound to Zeolite Matrix	Mole sieve	TA-16/21	NTS	10 g tritium in Type A w/ overpack	up to 10	1	2	1	1
Dispersible Depleted Uranium	Powder	SRS	TA-16/21	6 kg uranium in STC	2	2	4	2	2
Nondispersible Depleted Uranium	1/8-in. pellets	TA-16/21	Boston	6 kg uranium in STC	2	2	4	2	2
Neutron Tube Target	Tritium in solid storage	TA-16/21	SNL	≤ 1,000 Ci in Type A	up to 20	50	100	50	50
Off-Site Samples	Solid	TA-53	DOE Labs (uniform)	Type A	1 by FedEx	50	50	50	50
Neutron Scattering Research	Pressed powders	TA-53	Uniform U.S.	≤ 0.5 Ci J-L	1 by FedEx	12	12	12	12
Misc. Nuclear Materials	Double encapsulated	TA-53	Oak Ridge	1.4 mCi californium in 6M	1	1 (total) ^b	1 (total) ^b	1 (total) ^b	1 (total) ^b
Medical Isotopes	Liquid	TA-48	Uniform U.S.	Bounded by 2 Ci strontium-82 in Type A box by FedEx	1	160	160	160	160
Irradiated Targets	Nondispersible	TA-48	BNL	Shielded Type B	1	12	12	12	12
Experimental Samples	Solids	TA-48	Uniform U.S.	Shielded Type A	1	20	40	20	40
	Irradiated Targets	TA-35	Rochester, NY	0.5 Ci by FedEx	1	100	100	100	100
Beryllium Targets	H ₂ and H ₃ gas	TA-35	LLNL	1 Ci by FedEx	1	50	50	50	50
	Liquid	Boston	HRL	0.5 mCi by FedEx	3	50	100	16	50
Neutron Source Recovery	Encapsulated oxide	Uniform U.S.	CMR/TA-55	Type A, special form, 3 Ci plutonium-238	2	10	20	10	10
Neutron Source Recovery	Encapsulated oxide	Uniform U.S.	CMR/TA-55	6M (Type B) normal form, ≤ 10 g plutonium-238	2	190	380	190	190

TABLE F.5.3-1.—Off-Site Shipments of Radioactive Materials-Continued

PROGRAM/MATERIAL	FORM	ORIGIN	DESTINATION	PACKAGING AND AMOUNT ^a	PACKAGES PER SHIPMENT	SHIPMENTS PER YEAR BY ALTERNATIVE				COMMENT
						NO ACTION	EXPANDED	REDUCED	GREENER	
Neutron Source Recovery	Encapsulated oxide	Uniform U.S.	CMR/TA-55	Heavily shielded Type B, 30 gm plutonium-238	1	2	4	2	2	
Plutonium Research	Powder	SRS	TA-55	Not specified in reference	26	1 (total) ^b	1 (total) ^b	1 (total) ^b	1 (total) ^b	SST
Contaminated Laundry	Particulate-contaminated solid	SM-30	CA	Duffle bag in STC, RAM is near zero	about 200	52	81	52	52	Shipment amount will vary with alternative
Contact-Handled TRU	Solid	TA-54	WIIPP	TRUPACT-II	3	157	204	157	166	
TRU and Low-Level Waste	Solid	SNL	TA-54	17H Drum	-----	-----	-----	-----	-----	Included in contact-handled TRU
Remote-Handled TRU	Solid	TA-54	WIIPP	RH-72B	1	33	41	31	34	
Mixed Low-Level Waste	Solid/liquid/gas	TA-54	Various permitted facilities	17H Drum	65	33	33	33	33	Oak Ridge assumed
Low-Level Waste	Solid	TA-54	Utah/Nevada/Hanford	17H Drum	65	377	0	942	1,050	Primarily soil and debris
Total						2,440	4,244	2,894	3,132	

^a Refer to the packaging section F.2.0.

^b The total number of shipments over 10 years is listed. The annual total is the value divided by 10.

^c This reflects return of recovered plutonium to RFETS. It is possible that this material would remain at LANL, as reflected in the *Final Environmental Impact Statement on Management of Certain Plutonium Residues and Scrap Alloy Stored at the Rocky Flats Environmental Technology Site* (DOE/EIS-0277) (DOE 1998).

^d This surplus material is expected to leave LANL, eventually; however, without a site selection for the plutonium disposition program, the timing and location for such shipments is unknown. Except for material shipped as MOX fuel (see below), this material is expected to remain at LANL for the period addressed in the SWEIS.

^e The shipments to Y-12 exceed the receipts from Y-12 because of an excess inventory that currently exists at LANL. This excess inventory of material from a variety of research and development activities is expected to be reduced over the next several years, at which point the HEU received will be approximately equal to the HEU shipped out.

RFETS = Rocky Flats Environmental Technology Site, SRS = Savannah River Site, LLNL = Lawrence Livermore National Laboratory, CMR = Chemistry and Metallurgy Research, HEU = highly enriched uranium, CSA = canned subassembly, STCs = standard transportation containers, NTS = Nevada Test Site, BNL = Brookhaven National Laboratory, HRL = Health Research Laboratory

TABLE F.5.3-2.—On-Site Shipments of Radioactive Materials

PROGRAM/MATERIAL	FORM	ORIGIN	DESTINATION	PACKAGING AND AMOUNT ^a	PACKAGES PER SHIPMENT	SHIPMENTS PER YEAR BY ALTERNATIVE			COMMENT	
						NO ACTION	EXPANDED	REDUCED		GREENER
Plutonium (weapons grade) samples	Solid	TA-55	CMR	200 g plutonium (weapons grade) in 6M	10	100	150 ^b	100	100	
Plutonium (weapons grade) samples	Liquid	CMR	TA-55	6 L of plutonium (weapons grade) in 1.5-in. container	4	128	240 ^b	128	128	Road closure
Plutonium-238 samples	Solid	TA-55	CMR	20 Ci plutonium-238 in 6M	10	---	---	---	---	Combined with Pu (WG) samples
Plutonium-238 samples	Liquid	CMR	TA-55	6 L of plutonium-238 in 1.5-in. container	4	---	---	---	---	Combined with Pu (WG) samples
Low-Level Waste	Solid	TA-55	TA-54	2 ft ³ cardboard box	90	52	73	52	52	Compactible and in dumpster
	Solid	TA-55	TA-54	STC, Type A, or plastic wrap	6+12	9	15	9	9	Noncompactible
Contaminated Laundry	Particulate-contaminated solid	TA-55	SM-30	Duffie bag	Up to 40	250	250	250	250	Shipment size will vary with alternative
Radiography	Metal	TA-55	Varies	FL	1	100	500	24	100	Return included
Contact-handled TRU	Particulate-contaminated solid	TA-55	TA-54	17H drum, < 100 g SNM	16+40	78	158	62	78	Road closure
Surveillance	Metal	TA-55	CMR	FL	1	0	200 ^b	0	0	Return included
Research and Development	Metal	TA-55	CMR	FL	1	0	100 ^b	0	0	Return included
Research and Development	Powder	TA-55	CMR	Type B, 500 g	1	0	100 ^b	0	0	Return included
Contact-Handled TRU	Particulate-contaminated solid	CMR	TA-54	17H drum, < 100 g SNM	20+25	4	5	4	4	Road closure
HEU	Powder	TA-55	CMR	17H drum, < 300 g HEU	2	1	1	1	1	
Mixed Low-Level Waste	Liquid	CMR	TA-54	17H drum, 16 mg plutonium (weapons grade)	2	13	13	13	13	
	Particulate-contaminated solid	CMR	TA-54	17H drum, 16 mg plutonium (weapons grade)	2	13	13	13	13	
Mixed TRU	Particulate-contaminated solid	CMR	TA-54	17H drum, < 100 g SNM	1	---	---	---	---	Included in truck with C.12

TABLE F.5.3-2.—On-Site Shipments of Radioactive Materials-Continued

PROGRAM/MATERIAL	FORM	ORIGIN	DESTINATION	PACKAGING AND AMOUNT ^a	PACKAGES PER SHIPMENT	SHIPMENTS PER YEAR BY ALTERNATIVE				COMMENT
						NO ACTION	EXPANDED	REDUCED	GREENER	
CSA	Metal	TA-18	CMR	CSA	1	3	10	3	3	Road closure
	Metal	CMR	TA-18	CSA	1	3	10	3	3	Road closure
	Metal	CMR	TA-8	CSA	1	3	10	3	3	Road closure
CSA (continued)	Metal	TA-8	CMR	CSA	1	3	10	3	3	Road closure
	Misc. solids	TA-54	TA-50/CMR	≤ 1.8 Ci plutonium-239 and americium-241	10+18	7 (total) ^c	7 (total) ^c	7 (total) ^c	7 (total) ^c	Road closure, 1998, 1999, 2002. Return included
Neutron Source Recovery	Cemented	CMR	TA-54	17H drum, mCi level	40	2 (total) ^c	2 (total) ^c	2 (total) ^c	2 (total) ^c	1998, 2002
	Encapsulated oxide	SM-30	TA-55 (bounds CMR)	6M	2	202	404	202	202	10 g Pu-238 is accident analysis value; see off-site NS.1
Contaminated Laundry	Oxide	CMR	TA-55	Type B, 500 g	4+8	1 (total) ^c	1 (total) ^c	1 (total) ^c	1 (total) ^c	Bounding no action values are 1 kg Pu-238 and 3 kg Am-241
	Particulate-contaminated solid	CMR	SM-30	Duffie bag	Up to 10	250	250	250	250	Shipment amount will vary with alternative
Contingency SNM	Metal	CMR	TA-18	Type B, 20 Ci plutonium-239	10	10	20	10	10	
	Liquid	CMR	TA-18	6 L of Highly Enriched Uranium in 15-in. container	4	1	2	1	1	Road closure
Plutonium Objects	Metal	TA-18	CMR (bounding)	17H, 40 kg plutonium (weapons grade)	2	8	16	8	8	Road closure
	Adsorbed	TA-18	TA-48	Shielded Type A	1	0	12	0	0	
Highly Enriched Uranium Samples	Liquid	TA-18	CMR	Type A, 20 g	1	6	18	6	6	Return shipments included
	Particulate-contaminated solid	TA-18	CMR/TA-54	17H drum	12	1	1	1	1	Mileage is to/from CMR then to TA-54
Plutonium Parts	Metal	TA-18	CMR	FL	1	84	220	84	96	Most are to TA-55; CMR is used as bounding
	Metal	CMR	TA-18	FL	1	84	220	84	96	
MOX Fuel	Ceramic	TA-55	TA-18	Type B, 20 kg plutonium (weapons grade)	5	2 (total) ^c	2 (total) ^c	2 (total) ^c	2 (total) ^c	Return included
Contaminated Laundry	Particulate-contaminated solid	TA-18	SM-30	Duffie bag	Up to 30	24	48	24	24	Shipment amount will vary with alternative

TABLE F.5.3-2.—On-Site Shipments of Radioactive Materials-Continued

PROGRAM/MATERIAL	FORM	ORIGIN	DESTINATION	PACKAGING AND AMOUNT ^a	PACKAGES PER SHIPMENT	SHIPMENTS PER YEAR BY ALTERNATIVE			COMMENT	
						NO ACTION	EXPANDED	REDUCED GREENER		
MC&A Highly Enriched Uranium Measurements	Metals, oxides, or ceramics	TA-18	CMR	20 to 40 kg	Unspecified	24	48	24	24	Return included
Radiography	Solids	TA-8	TA-18	Unspecified	Unspecified	12	24	12	12	Road closure
	Mole sieve	TA-18	TA-55	Unspecified	Unspecified	12	24	12	12	Road closure
Tritiated Water Bound to Zeolite Matrix	Mole sieve	TA-21/16	TA-54	≤ 10 g in package	Up to 10	5	10	5	5	Road closure
Sealed Source	Triple encapsulated	TA-55	TA-16	Type A, special form 0.01 g plutonium-238	≤ 4	3	3	3	3	
Dispersible Depleted Uranium	Powder (assumed)	TA-21	TA-16	6 kg uranium in STC	2	4	8	4	4	Return included
Bulk Tritium	Gas or solid storage	TA-16/21	TA-16/21	≤ 120 g per shipment	Up to 10	20	20	20	20	May close roads
	Gas or solid storage	TA-16/21	TA-16/21	≤ 1,000 Ci per package	Up to 10	20	20	20	20	May close roads
Nondispersible Depleted Uranium	1/8-in. pellets	TA-16/21	TA-16/21	≤ 6 kg/STC	Up to 2	2	4	2	2	
Neutron Tube Target	H ₃ in solid storage	TA-16/21	TA-16/21	≤ 1,000 Ci per package	Up to 5	50	100	50	50	
Depleted Uranium Materials	Bulk metal	TA-8 (bounds shops)	Sigma	200 kg uranium in STC	1	900	3,780	900	900	Return included
	Pyrophoric metal	Sigma	TA-54	60 kg uranium in 7A drum	7	12	48	12	12	Ash portion is not pyrophoric
Low-Level Waste	Fixed surface contamination	Sigma	TA-54	Low Depleted Uranium in STC	3	13	55	13	13	Noncompactible
Contaminated Laundry	Particulate-contaminated solid	Sigma	SM-30	Duffie bag	30	24	101	24	24	Shipment amount will vary with alternative
Highly Enriched Uranium	Bulk metal	CMR	TA-8 (bounds shops)	20 kg Highly Enriched Uranium in Type A	5	0	240	0	0	Closed roads, return included
Inserts and Beam Stops	Activated components	TA-53	TA-54	Shielded cask	1	12	12	12	12	Unshielded radiation levels from few to 2 × 10 ⁵ R/h
Irradiated targets	Activated components	TA-53	TA-48	Shielded cask	1	15	17	8	17	Unshielded radiation level up to 5 × 10 ⁴ R/h
Low-Level Waste	Solid	TA-53	TA-54	2 ft ³ cardboard box	80	5	5	5	5	Compactible and in dumpster
	Solid	TA-53	TA-54	B-25 box	1	2	2	2	2	

TABLE F.5.3-2.—On-Site Shipments of Radioactive Materials-Continued

PROGRAM/MATERIAL	FORM	ORIGIN	DESTINATION	PACKAGING AND AMOUNT ^a	PACKAGES PER SHIPMENT	SHIPMENTS PER YEAR BY ALTERNATIVE				COMMENT
						NO ACTION	EXPANDED	REDUCED	GREENER	
Misc. Material	Double encapsulated	TA-53	TA-55	6M, <5 Ci americium-241	1	2 (total) ^c	2 (total) ^c	2 (total) ^c	2 (total) ^c	One shipment is 4.95 Ci Am-241, other 1.83 Ci Pu-238
	Liquid	TA-53	TA-48	17H drum, 525 kg D ₂ O	3	1 (total) ^c	1 (total) ^c	1 (total) ^c	1 (total) ^c	
Activated Material	Solid	TA-53	TA-54	Various	2	15	15	15	15	Number of shipments averaged over 10 years
Activated Components	Solid	TA-53	TA-54	Various	1	0	220	0	220	Number of shipments averaged over 10 years, but actually occur 2000 to 2005
Hot Cell Waste	Particulate-contaminated solids or liquids	TA-48	TA-54	Shielded Type A	1	3	3	3	3	Compactible, radiation levels up to 10 R/h
		TA-48	TA-54	Shielded cask	1	18	18	18	18	
Low-Level Waste	Solids or Tritium in solid storage	Various (TA-3 bounding)	TA-16, TA-15, or similar	Various	1	477	886	471	471	Noncompactible radiation levels up to 300 R/h One shipment of DU, H ₃ , etc. per experiment assumed
		TA-16 or similar	TA-15 or similar	Various	1	477	886	471	471	
Low-Level Waste	Solid	TA-3 or similar	TA-54	2 ft ³ cardboard box	90	284	418	271	335	Compactible and in dumpster
Low-Level Waste	Solid	TA-3 or similar	TA-54	B-25 box	2	193	278	181	205	Noncompactible
Low-Level Waste	Solid	TA-3 or similar	TA-54	Dump truck	1	215	269	361	259	Soil and building debris
Low-Level Waste	Solid	TA-3 or similar	TA-54	Various	Unspecified	33	77	105	47	Scrap metal
Low-Level Mixed Waste	Liquid	TA-3 or similar	TA-54	17H Drum	10	20	20	20	20	
Low-Level Mixed Waste	Solid	TA-3 or similar	TA-54	Dump truck	1	53	53	53	53	Soils and debris
Low-Level Mixed Waste	Solid	TA-3 or similar	TA-54	96 ft ³ box	2	18	20	18	18	Contaminated lead and non-RCRA
Total						4,372	10,754	4,454	4,727	

^a Refer to the packaging section F.2.0.
^b These shipments constitute the approximately 500-shipment increase discussed in volume II, part II (PSSC Analysis for the Enhancement of Plutonium Pit Manufacturing), section II.2.1.1.
^c The total number of shipments over 10 years is listed. The annual total is the value divided by 10.
 CSA = canned subassembly, MC&A = Materials Control and Accountability, STCs = standard transportation containers

decrease over time as the excess material in the current inventory is shipped off site.

The HAZMAT shipments were determined primarily by using LANL databases such as the Automated Chemical Inventory System (ACIS) and STORES as well as by using the SMAC data. Large inventories and bulk shipments were of special interest. When such inventories and bulk shipments were identified, responsible personnel were interviewed. The bounding historical material types and quantities identified in Table F.5.2–1 were validated for the toxic and explosive material categories. The bounding flammable material was changed from hydrogen to propane because the potential consequence of a propane release was determined to be larger as a result of the differing dispersion characteristics of lighter-than-air hydrogen and heavier-than-air propane (subsection F.6.5.4). The maximum future explosive shipment size for truck was determined to be 40,000 pounds (18,000 kilograms). Explosive shipments this large have been received in the past and could be received in the future.

An extensive analysis of on-site HAZMAT shipments determined that the large toxic, flammable, and explosive off-site shipments bound the accident risk both on site and off site.

Off-site shipments of toxic and flammable material classes were assumed to increase from the values in Table F.5.2–2 and vary with the SWEIS alternatives in the same way the off-site RAM shipments increase from the values in Table F.5.2–2 and vary with the SWEIS alternatives as described in Table F.5.3–1.

Although the number of many types of operational shipments associated with the Reduced Operations Alternative are lower than in the other alternatives, the number of low-level waste (LLW) shipments for off-site disposal increases substantially as compared to the number of LLW shipments under the No Action Alternative (since the Reduced

Operations Alternative reflects off-site disposal of most LLW). This results in a total for off-site shipment mileage under the Reduced Operations Alternative, which is greater than the total off-site shipment mileage under the No Action Alternative. For this reason, the impacts that depend on the total off-site or radioactive shipment mileage are higher under the Reduced Operations Alternative than under the No Action Alternative.

The baseline value of off-site shipments in Table F.5.2–2 is the starting point for HAZMAT off-site shipments, after it is adjusted upward by the ratio of RAM shipments in Tables F.5.2–2 and F.5.3–1. In the case of toxic and flammable materials, the values are then adjusted for the SWEIS alternatives by the ratio of the number shipments under Expanded Operations, Reduced Operations, and Greener Alternatives to the No Action shipments in Table F.5.3–1. Projections, by alternative, were available for large off-site shipments of explosives. The on-site HAZMAT shipments were assumed to increase from the values in Table F.5.2–2 and vary with SWEIS alternatives in the same way as the on-site RAM shipments increase from Table F.5.2–2 to Table F.5.3–2 and vary with SWEIS alternative.

The resulting annual number of significant HAZMAT shipments for each alternative are given in Table F.5.3–3. The ratio of significant to total shipments is the same as that in Table F.5.2–1. As before, a large shipment is one that is greater than 10 percent of the maximum shipment quantity.

F.6 IMPACT ANALYSIS RESULTS

F.6.1 Introduction

To determine the impacts of the transportation of RAM and HAZMAT, four risk measures are defined in subsections F.3.3 and F.3.4: truck emissions in urban areas, truck accident injuries and fatalities that are independent of the nature

TABLE F.5.3-3.—Annual Number of Hazardous Material Truck Shipments for SWEIS Alternatives

SHIPMENT TYPE	ALTERNATIVE							
	NO ACTION		EXPANDED OPERATIONS		REDUCED OPERATIONS		GREENER	
	TOTAL SIGNIFICANT	TOTAL LARGE	TOTAL SIGNIFICANT	TOTAL LARGE	TOTAL SIGNIFICANT	TOTAL LARGE	TOTAL SIGNIFICANT	TOTAL LARGE
Off-Site, Toxic	645	90	1,439	200	606	84	645	90
Off-Site, Flammable	1,382	73	3,081	164	1,299	70	1,382	73
Off-Site, Explosive	518	2	1,155	2	487	1	518	1
On-Site	14,628	NA	34,231	NA	14,189	NA	15,068	NA

of the cargo, incident-free radiation exposure, and accidents resulting in a release of RAM or HAZMAT.

The RAM shipments presented by alternative (as in Tables F.5.3-1 and F.5.3-2) were identified for a specific origin/destination, or were categorized as going to one of five regions: northeast, southeast, northwest, southwest, or New Mexico. A centroid (central location) was picked for each of these regions on the basis of historical and projected shipments: Concord, Massachusetts; Aiken, South Carolina; Richland, Washington; Berkeley, California; and Albuquerque, New Mexico. The distances from LANL to the centroids are given in Table F.6.1-1. The shipment distances for explosives, flammable materials, and toxic materials were based on the corresponding large truck shipments in Table F.5.2-1. The centroids selected were Ft. Smith, Arkansas; Phoenix, Arizona; and Milwaukee, Wisconsin, respectively. All distances given in Table F.6.1-1 were determined from the HIGHWAY code (Johnson et al. 1993) and include the distances between LANL and I-25, as presented in Table F.4.3-1.

F.6.2 Truck Emissions in Urban Areas

The truck emission risk is based on 1.0×10^{-7} excess LCF per truck kilometer in urban areas where the number of kilometers is obtained as described in section F.4.3. Because Los Alamos is not an urban area, only off-site shipments were addressed in this analysis (off-site shipments by alternative are presented in Tables F.5.3-1 [RAM] and F.5.3-3 [HAZMAT]). The total distance traveled in urban areas in a year is calculated for these shipments using the distances in Table F.6.1-1, and the corresponding excess LCFs are calculated using the conversion factor presented above. The results are presented in Table F.6.2-1. Approximately 65 percent of the excess LCFs are due to RAM shipments and 35 percent are due to HAZMAT shipments. All shipments are conservatively assumed to result in an empty truck making the return trip. This is appropriate for WIPP shipments and many SST trailer shipments; however, most shipments are in general commerce and would not include the return of an empty truck.

TABLE F.6.1-1.—Off-Site Shipment Distance per Trip

ROUTE	MILES (KILOMETERS) IN URBAN AREAS	MILES (KILOMETERS) IN SUBURBAN AREAS	MILES (KILOMETERS) IN RURAL AREAS
Northeast, RAM	63 (102)	511 (823)	1,647 (2,652)
Southeast, RAM	20 (32)	275 (442)	1,312 (2,113)
Northwest, RAM	17 (27)	118 (190)	1,092 (1,759)
Southwest, RAM	20 (32)	75 (120)	1,094 (1,762)
Toxic Material	22 (36)	152 (245)	1,230 (1,981)
Flammable Material	13 (21)	50 (80)	496 (799)
Explosive Material	6 (10)	63 (102)	684 (1,102)

TABLE F.6.2-1.—Number of Excess Latent Cancer Fatalities Due to Truck Emissions in Urban Areas

RISK MEASURE	ALTERNATIVE			
	NO ACTION	EXPANDED OPERATIONS	REDUCED OPERATIONS	GREENER
Excess LCF per Year	3.2×10^{-2}	6.6×10^{-2}	3.4×10^{-2}	3.6×10^{-2}

F.6.3 Truck Accident Injuries and Fatalities

The HIGHWAY code (Johnson et al. 1993) was used to determine the distance traveled in each state for each of the centroids described in subsection F.6.1. The truck accident fatality, injury, and total accident rates in each state were taken from Saricks and Kvittek (1994). The rates in Table F.4.2.2–1 were used between Santa Fe and LANL, and the rates in Table F.4.2.3–1 were used on site. The results are given in Tables F.6.3–1 through F.6.3–3 for fatalities, injuries, and total accidents, respectively. Approximately 65 percent of the impacts are due to RAM shipments, and 35 percent are due to HAZMAT shipments. Again, all shipments are assumed to result in a return by an empty truck.

F.6.4 Incident-Free Radiation Exposure

The RADTRAN and ADROIT codes are used with the estimated number of off-site shipments in Tables F.5.3–1 and F.5.3–2 and with the estimated package surface radiation levels to obtain the results shown in Tables F.6.4–1 through F.6.4–4. The aircraft segment is for overnight carrier service; the truck segment to/from the airport is included in the truck results.

MEI dose occurs between LANL and I-25 and is 3.0×10^{-4} , 3.8×10^{-4} , 3.2×10^{-4} , and 3.4×10^{-4} rem for the No Action, Expanded Operations, Reduced Operations, and Greener Alternatives, respectively.

F.6.4.1 Driver Doses from On-Site Shipments of Radioactive Materials

The number of on-site shipments of RAM for the baseline year 1994, was 1,187 shipments, (taken from Table F.5.2–2). The baseline number of on-site shipments of RAM for the

four SWEIS alternatives was taken from Table F.5.2–3. Table F.6.4.1–1 presents a summary of the total number of on-site shipments for all alternatives.

Dosimetry data for 25 on-site LANL drivers were provided by LANL. For identification purposes, the drivers were assigned numbers 1 through 25. Driver doses for 1994 were extracted from the dosimetry data package and are summarized in Table F.6.4.1–2. Driver number 2 did not have any dosimetry data for years beyond 1992, therefore, it was assumed that this driver is no longer working at LANL. He was dropped from further analysis. The driver doses were, therefore, based on 24 drivers.

To evaluate driver doses for the different SWEIS alternatives, it was assumed that the number of drivers (24) would be the same under each of the alternatives. In calculating the cancer risk associated with these doses, a dose-to-risk conversion factor 4×10^{-4} excess LCFs per person-rem was used (ICRP 1991).

To evaluate doses associated with on-site shipments for the different alternatives, the following procedure was followed:

- A dose per shipment was calculated for the baseline year as follows:
 - Dose (person-rem per shipment) = (total collective dose) per number of shipments.

$$= 9.57 \times 10^{-4}$$
 - The baseline total dose of 1.136 person-rem was taken from Table F.6.4.1–2.
 - The total number of shipments for each alternative was then multiplied by 9.57×10^{-4} to obtain the total collective dose per alternative.
 - The total dose per alternative was then divided by 24 (the number of drivers) to obtain the average driver dose for each alternative.

TABLE F.6.3-1.—Annual Truck Accident Fatalities

ROUTE SEGMENT	ALTERNATIVE			
	NO ACTION	EXPANDED OPERATIONS	REDUCED OPERATIONS	GREENER
On-Site	1.5×10^{-4}	3.3×10^{-4}	1.4×10^{-4}	1.5×10^{-4}
LANL to U.S. 84/285	1.7×10^{-3}	3.4×10^{-3}	1.8×10^{-3}	1.9×10^{-3}
U.S. 84/285 to I-25	4.1×10^{-3}	8.2×10^{-3}	4.3×10^{-3}	4.6×10^{-3}
Remainder of New Mexico	7.2×10^{-2}	1.5×10^{-1}	7.5×10^{-2}	8.0×10^{-2}
Outside New Mexico	3.0×10^{-1}	6.2×10^{-1}	3.3×10^{-1}	3.5×10^{-1}
Total	3.8×10^{-1}	7.8×10^{-1}	4.1×10^{-1}	4.4×10^{-1}

TABLE F.6.3-2.—Annual Truck Accident Injuries

ROUTE SEGMENT	ALTERNATIVE			
	NO ACTION	EXPANDED OPERATIONS	REDUCED OPERATIONS	GREENER
On-Site	3.1×10^{-3}	7.0×10^{-3}	2.9×10^{-3}	3.2×10^{-3}
LANL to U.S. 84/285	3.5×10^{-2}	7.1×10^{-2}	3.7×10^{-2}	4.0×10^{-2}
U.S. 84/285 to I-25	8.6×10^{-2}	1.8×10^{-1}	9.1×10^{-2}	9.7×10^{-2}
Remainder of New Mexico	6.4×10^{-1}	1.3×10^0	6.8×10^{-1}	7.2×10^{-1}
Outside New Mexico	3.0×10^0	6.0×10^0	3.3×10^0	3.6×10^0
Total	3.8×10^0	7.6×10^0	4.1×10^0	4.5×10^0

TABLE F.6.3-3.—Number of Annual Truck Accidents

ROUTE SEGMENT	ALTERNATIVE			
	NO ACTION	EXPANDED OPERATIONS	REDUCED OPERATIONS	GREENER
On-Site	1.5×10^{-2}	3.3×10^{-2}	1.4×10^{-2}	1.5×10^{-2}
LANL to U.S. 84/285	1.7×10^{-1}	3.4×10^{-1}	1.8×10^{-1}	1.9×10^{-1}
U.S. 84/285 to I-25	4.1×10^{-1}	8.2×10^{-1}	4.3×10^{-1}	4.6×10^{-1}
Remainder of New Mexico	6.7×10^{-1}	1.4×10^0	7.0×10^{-1}	7.6×10^{-1}
Outside New Mexico	3.2×10^0	6.4×10^0	3.6×10^0	3.8×10^0
Total	4.5×10^0	9.0×10^0	4.9×10^0	5.2×10^0

TABLE F.6.4-1.—Annual Incident-Free Population Dose and Excess Latent Cancer Fatality for the No Action Alternative

ROUTE SEGMENT	TRUCK OR AIR CREW		NONOCCUPATIONAL					
			ALONG ROUTE		SHARING ROUTE		STOPS	
	PERSON-REM/ YEAR	EXCESS LCF/ YEAR	PERSON-REM/ YEAR	EXCESS LCF/ YEAR	PERSON-REM/ YEAR	EXCESS LCF/ YEAR	PERSON-REM/ YEAR	EXCESS LCF/ YEAR
LANL to U.S. 84/285	5.9×10^0	2.4×10^{-3}	3.2×10^{-2}	1.6×10^{-5}	5.1×10^{-1}	2.6×10^{-4}	3.2×10^0	1.6×10^{-3}
U.S. 84/285 to I-25	7.9×10^0	3.2×10^{-3}	3.8×10^{-1}	1.9×10^{-4}	3.6×10^0	1.8×10^{-3}	3.3×10^0	1.6×10^{-3}
Remainder of New Mexico	4.5×10^1	1.8×10^{-2}	1.0×10^{-1}	5.0×10^{-5}	1.7×10^0	8.5×10^{-4}	2.4×10^1	1.2×10^{-2}
Outside New Mexico	4.1×10^2	1.6×10^{-1}	2.8×10^0	1.4×10^{-3}	2.4×10^1	1.2×10^{-2}	1.8×10^2	9.0×10^{-2}
Aircraft	2.4×10^0	1.2×10^{-3}	NA	NA	NA	NA	NA	NA

NA = Not applicable

TABLE F.6.4-2.—Annual Incident-Free Population Dose and Excess Latent Cancer Fatality for the Expanded Operations Alternative

ROUTE SEGMENT	TRUCK OR AIR CREW		NONOCCUPATIONAL					
			ALONG ROUTE		SHARING ROUTE		STOPS	
	PERSON-REM/ YEAR	EXCESS LCF/ YEAR	PERSON-REM/ YEAR	EXCESS LCF/ YEAR	PERSON-REM/ YEAR	EXCESS LCF/ YEAR	PERSON-REM/ YEAR	EXCESS LCF/ YEAR
LANL to U.S. 84/285	7.4×10^0	3.0×10^{-3}	4.0×10^{-2}	2.0×10^{-5}	6.5×10^{-1}	3.2×10^{-4}	4.0×10^0	2.0×10^{-3}
U.S. 84/285 to I-25	1.0×10^1	4.0×10^{-3}	4.9×10^{-1}	2.4×10^{-4}	4.6×10^0	2.3×10^{-3}	4.2×10^0	2.1×10^{-3}
Remainder of New Mexico	5.5×10^1	2.2×10^{-2}	1.2×10^{-1}	6.2×10^{-5}	2.1×10^0	1.0×10^{-3}	3.0×10^1	1.5×10^{-2}
Outside New Mexico	5.1×10^2	2.0×10^{-1}	3.5×10^0	1.8×10^{-3}	3.0×10^1	1.5×10^{-2}	2.3×10^2	1.2×10^{-1}
Aircraft	2.4×10^0	1.2×10^{-3}	NA	NA	NA	NA	NA	NA

NA = Not applicable

TABLE F.6.4-3.—Annual Incident-Free Population Dose and Excess Latent Cancer Fatality for the Reduced Operations Alternative

ROUTE SEGMENT	TRUCK OR AIR CREW		NONOCCUPATIONAL					
			ALONG ROUTE		SHARING ROUTE		STOPS	
	PERSON -REM/ YEAR	EXCESS LCF/ YEAR	PERSON -REM/ YEAR	EXCESS LCF/ YEAR	PERSON-REM/ YEAR	EXCESS LCF/ YEAR	PERSON -REM/ YEAR	EXCESS LCF/ YEAR
LANL to U.S. 84/285	6.4 x 10 ⁰	2.6 x 10 ⁻³	3.4 x 10 ⁻²	1.7 x 10 ⁻⁵	5.6 x 10 ⁻¹	2.8 x 10 ⁻⁴	3.4 x 10 ⁰	1.7 x 10 ⁻³
U.S. 84/285 to I-25	8.7 x 10 ⁰	3.5 x 10 ⁻³	4.2 x 10 ⁻¹	2.1 x 10 ⁻⁴	3.4 x 10 ⁰	1.7 x 10 ⁻³	3.6 x 10 ⁰	1.8 x 10 ⁻³
Remainder of New Mexico	5.0 x 10 ¹	2.0 x 10 ⁻²	1.2 x 10 ⁻¹	6.0 x 10 ⁻⁵	1.9 x 10 ⁰	9.5 x 10 ⁻⁴	2.7 x 10 ¹	1.4 x 10 ⁻²
Outside New Mexico	4.4 x 10 ²	1.8 x 10 ⁻¹	2.9 x 10 ⁰	1.4 x 10 ⁻³	2.5 x 10 ¹	1.2 x 10 ⁻⁴	2.0 x 10 ²	1.0 x 10 ⁻¹
Aircraft	2.4 x 10 ⁰	1.2 x 10 ⁻³	NA	NA	NA	NA	NA	NA

NA = Not applicable

TABLE F.6.4-4.—Annual Incident-Free Population Dose and Excess Latent Cancer Fatality for the Greener Alternative

ROUTE SEGMENT	TRUCK OR AIR CREW		NONOCCUPATIONAL					
			ALONG ROUTE		SHARING ROUTE		STOPS	
	PERSON -REM/ YEAR	EXCESS LCF/ YEAR	PERSON -REM/ YEAR	EXCESS LCF/ YEAR	PERSON-REM/ YEAR	EXCESS LCF/ YEAR	PERSON -REM/ YEAR	EXCESS LCF/ YEAR
LANL to U.S. 84/285	6.8 x 10 ⁰	2.7 x 10 ⁻³	3.6 x 10 ⁻²	1.8 x 10 ⁻⁵	5.9 x 10 ⁻¹	3.0 x 10 ⁻⁴	3.6 x 10 ⁰	1.8 x 10 ⁻³
U.S. 84/285 to I-25	9.2 x 10 ⁰	3.7 x 10 ⁻³	4.4 x 10 ⁻¹	2.2 x 10 ⁻⁴	4.2 x 10 ⁰	2.1 x 10 ⁻³	3.8 x 10 ⁰	1.9 x 10 ⁻³
Remainder of New Mexico	5.2 x 10 ¹	2.1 x 10 ⁻²	1.3 x 10 ⁻¹	6.5 x 10 ⁻⁵	2.0 x 10 ⁰	1.0 x 10 ⁻³	2.8 x 10 ¹	1.4 x 10 ⁻²
Outside New Mexico	4.6 x 10 ²	1.8 x 10 ⁻¹	3.0 x 10 ⁰	1.5 x 10 ⁻³	2.6 x 10 ¹	1.3 x 10 ⁻⁴	2.1 x 10 ²	1.0 x 10 ⁻¹
Aircraft	2.4 x 10 ⁰	1.2 x 10 ⁻³	NA	NA	NA	NA	NA	NA

NA = Not applicable

TABLE F.6.4.1-1.—Annual Doses and Cancer Risks to Drivers from On-Site Shipment of Radioactive Materials

	BASELINE (1994)	NO ACTION	EXPANDED OPERATIONS	REDUCED OPERATIONS	GREENER
Number of Shipments	1,187	4,372	10,754	4,454	4,728
Collective Driver Dose (person-rem) ^a	1.136	4.184	10.292	4.262	4.525
Average Driver Dose (rem) ^b	0.047	0.174	0.429	0.178	0.189
Cancer Risk ^c	4.54×10^{-4}	1.67×10^{-3}	4.12×10^{-3}	1.70×10^{-3}	1.81×10^{-3}

^a This is the total collective dose to all 24 drivers working at LANL. This dose was obtained by multiplying the total number of shipments by 9.57×10^{-4} .

^b This is the annual average dose to each of the 24 drivers, obtained by dividing the total dose by 24.

^c This is the sum of the excess LCF to all drivers from exposure to low level radiation. A dose-to-risk conversion factor of 4×10^{-4} is used.

TABLE F.6.4.1-2.—*Driver Dose Data for On-Site Shipments in 1994*

DRIVER NUMBER	SKIN DOSE (REM)	DEEP DOSE (REM)	NEUTRON DOSE (REM)	TOTAL DRIVER DOSE (REM)
1	0	0	0	0
2 ^a	—	—	—	—
3	0	0	0	0
4	0	0	0	0
5	0	0	0	0
6	0.01	0	0	0.01
7	0	0	0	0
8	0	0	0	0
9	0	0	0	0
10	0	0	0	0
11	0	0	0	0
12	0	0	0	0
13	0	0	0	0
14	0	0	0	0
15	0.031	0	0.008	0.039
16	0.017	0	0	0.017
17	0.212	0.169	0.01	0.391
18	0.216	0.163	0	0.379
19	0.013	0	0	0.013
20	0.116	0.01	0.059	0.185
21	0.029	0	0	0.029
22	0	0	0	0
23	0	0	0	0
24	0.03	0	0.015	0.045
25	0.014	0.014	0	0.028
Total Collective Dose (person-rem/year)	0.688	0.356	0.092	1.136
Average Driver Dose (rem/year)	0.029	0.015	0.004	0.047

^a No 1994 dosimetry data were available for driver No. 2. It was assumed that the driver left the job prior to 1994, and therefore he was dropped from the analysis.

- The collective driver dose was multiplied by a dose-to-risk conversion factor of 4×10^{-4} (cancer deaths per person-rem) to obtain the cancer risk.

The results for driver doses and associated risks are presented in Table F.6.4.1–1. The average driver doses are well below the DOE radiation protection standard of 5 rem per year. The highest collective dose (under the Expanded Operations Alternative) is just over 10 person-rem per year. The cancer risk associated with this dose is 4.12×10^{-3} excess LCFs per year.

F.6.5 Accidents

Analyses are conducted for scenarios leading to the release of either RAM or HAZMAT. The materials selected for analysis are those that represent bounding risks. Results are given for off-site shipments of RAM and HAZMAT. This subsection concludes with results for on-site RAM shipment.

F.6.5.1 Determination of Bounding Materials

Selection of the bounding material shipments is described in the following subsections.

Radioactive Materials

The shipments described in Tables F.5.3–1 and F.5.3–2 were evaluated as described in this subsection to determine those that would likely present the largest risk. These are referred to as the bounding materials. To determine the transportation risk, the shipment of bounding materials is evaluated in more detail. The bounding materials are those that have the largest value of

$$\text{MAR} \times \text{ARF} \times \text{RF} \times \text{ID}, \quad (\text{F-4})$$

Where:

MAR = material at risk (gram),

ARF = airborne release fraction,

RF = respirable fraction, and

ID = inhalation dose conversion factor (rem per gram).

The ARF values used are the RADTRAN default values, e.g., 1×10^{-6} for bulk metal, 1×10^{-2} for chunks, 1×10^{-1} for powder, and 1.0 for gases and volatile liquids. The RADTRAN default value for RF is 1.0 for gases and volatile liquids and 0.05 otherwise.

The bounding shipments determined by this approach are as follows:

- Off-site in an SST, plutonium-238 oxide powder (Table F.5.3–1, entries for plutonium operations and plutonium-238 heat source shipments to SRS)
- Off-site, americium-241 standards (Table F.5.3–1, americium-241 standard sales entry)
- On-site, plutonium-238 solution samples (Table F.5.3–2, entries for weapons grade plutonium and plutonium-238 liquid samples)

Equation F–4 is for materials that are hazardous due to their dispersion and subsequent exposure of persons to the airborne material. Another hazard is direct radiation from irradiated targets should the packaging fail (entry for irradiated targets in Table F.5.3–2). This hazard is bounding for its type. Some shipments associated with the Dual Axis Radiographic Hydrodynamic Test (DARHT) Facility are explosively configured, and the quoted values for ARF do not apply. DARHT shipments were not considered explicitly as bounding material; instead, the results from the DARHT EIS (DOE 1995) were incorporated into subsection F.6.5.5.

Risk includes both the consequence and the frequency of an event (subsection F.3.2). The bounding shipments were selected to produce

the highest calculated consequence. The frequency associated with the calculated bounding consequence is determined by adding together the number of bounding shipments and any other shipment that has a consequence (as estimated by using Equation F-4) that is greater than 10 percent of the bounding consequence. This approach is conservative and is used for both RAM and HAZMAT shipments.

Shipments of CH TRU to WIPP exceed the 10 percent criterion and would be included in the frequency term for off-site shipments of americium-241 standards, but RH TRU shipments do not exceed the 10 percent criterion. Both shipment types are analyzed explicitly in this appendix because of the potential public interest in the results. Off-site shipments of pits in an SST trailer were also analyzed explicitly for the same reason.

Off-site shipments of plutonium-238 oxide powder in an SST trailer were conservatively aggregated with other strategic nuclear material also shipped in SST trailers. (ADROIT analyses of SST shipments were provided by SNL).

On-site shipments of some activated components (e.g., beam stops) as a result of accelerator operations exceed the 10 percent criterion and are included in the frequency term for on-site shipments of irradiated targets, as are DARHT shipments. (Some activated components may exceed the radiation level for irradiated targets, but irradiated targets are judged to pose the greater risk due to the packaging.)

On-site shipments of weapons-grade plutonium solution samples are included in the plutonium-238 solution samples frequency term.

Description of Bounding Radioactive Material Shipments

Pressed plutonium-238 oxide powder is enclosed in a welded capsule that is then enclosed in a welded vessel. The vessel is

loaded into the 5320 packaging described in subsection F.2.4.5. Powder is transported to LANL from the Savannah River Site (SRS) in an SST. The 5320 package limit is 12.6 ounces (357 grams) of plutonium, but 15.6 ounces (441 grams) (17.6 ounces [500 grams] as plutonium dioxide) was used in the analysis to allow for possible increases in loading with another package.

The FL-Type container described in subsection F.2.4.1 is used to transport pits in an SST.

Up to 1 ounce (28 grams) americium-241 may be shipped in oxide form in a 30-gallon (114-liter) 6M package (subsection F.2.4.4); up to four packages may be shipped at a time. The oxide is enclosed in a stainless steel vial with a screw top and the vial is enclosed in a crimped can. This assembly is then placed in a 2R container in the 6M package.

Wastes transported to WIPP are enclosed in either the TRUPACT-II packaging described in subsection F.2.4.2 or the 72-B cask described in subsection F.2.4.6. One 72-B cask or three TRUPACT-II packages are transported in a single shipment. The waste parameters are those used in the WIPP Draft Supplemental EIS (DOE 1990c); additional details can be obtained from that document.

Samples of plutonium-238 in solution are transported from the Chemistry and Metallurgy Research (CMR) Facility to TA-55 in an armored vehicle that carries one to four packages. Each package consists of a stainless steel container enclosing three 0.5-gallon (2-liter) bottles. Each bottle is double sealed in plastic bags. The maximum concentration is 0.07 ounce (2 grams) plutonium-238 per 0.5-gallon (2-liter) bottle; all shipments are conservatively assumed to be at the maximum concentration. The LANL roads used are closed to traffic during the shipment.

The irradiated target package is a cylinder measuring 44 inches (112 centimeters) high,

with a 26-inch (66-centimeter) diameter. The packaging is constructed of 5.8 tons (5.266 kilograms) of depleted uranium, lead, and stainless steel. The package is equipped with a sliding door on the bottom so that targets can be loaded into the packaging by means of special remote handling tools. The package is transported on a dedicated truck that has a keyhole-shaped receptacle recessed into the bed.

F.6.5.2 ***Analysis of Off-Site Accidents Producing Bounding Radioactive Materials Releases***

The RADTRAN and ADROIT codes were used to analyze the bounding off-site RAM shipments described in subsections F.6.5.1. The MEI doses do not vary with route segment or alternative and are given in Table F.6.5.2–1 for each material analyzed with RADTRAN. ADROIT results that are separated into frequency and consequence components are not readily available. The product, MEI dose risk, varies with the number of shipments and the various shipment types. The population dose risks (consequence times frequency) and corresponding excess LCF risks are given in Tables F.6.5.2–2 through F.6.5.2–5 for each alternative.

F.6.5.3 ***Analysis of Accidents Producing Chlorine Releases***

An event tree analysis produced the following accident scenarios that could lead to a major chlorine release:

- Release from a small hole caused by a puncture of the cylinder or failure of a valve from puncture or impact accidents
- Opening of a fusible plug as a result of fire
- Catastrophic failure in an impact accident
- Catastrophic failure as a result of a fire

The probability of each of these scenarios was determined from the event trees by using 1-ton (908-kilogram) container failure thresholds (Rhyne 1994a) and force magnitude probabilities (Dennis et al.). (Although LANL is not expected to store or handle chlorine containers this large, they have in the past, and the risks associated with transport of this size container bound the risks of toxic material shipments.) The ALOHA computer model (NSC 1995) was used to estimate release rates from the 1-ton (908-kilogram) container, and the DEGADIS (Havens and Spicer 1985) dense gas dispersion model was used to predict downwind chlorine concentrations following the four postulated releases. (A separate version of DEGADIS is used because the version incorporated in ALOHA does not readily provide time variation of downwind concentrations.)

In this analysis, exposures to toxic chemicals are compared to Emergency Response Planning Guidelines (ERPGs). ERPGs are explained in detail in appendix G, section G.2.2. ERPG–2 is the maximum airborne concentration below which it is believed that nearly all individuals could be exposed for up to 1 hour without experiencing or developing irreversible or other serious health effects or symptoms that could impair their abilities to take protective action. ERPG–3 is the maximum airborne concentration below which it is believed that nearly all individuals could be exposed for up to 1 hour without experiencing or developing life-threatening health effects. The model predicts the length and width of the cloud for which concentrations are greater than those at ERPG–2 and ERPG–3. The area affected, the maximum exposure duration, the maximum downwind distance affected, and the maximum chlorine cloud width are shown in Table F.6.5.3–1 for the bounding release, which is release from a small hole with fire. (Catastrophic releases are of very short duration and a high escape fraction is likely.)

TABLE F.6.5.2-1.—Maximally Exposed Individual Doses and Associated Frequencies for Off-Site Radioactive Materials Accidents

ROUTE SEGMENT	SHIPMENT TYPE					
	AMERICIUM-241		CH TRU		RH TRU	
	MEI DOSE (REM)	FREQUENCY PER TRIP	MEI DOSE (REM)	FREQUENCY PER TRIP	MEI DOSE (REM)	FREQUENCY PER TRIP
LANL to U.S. 84/285	59	1.8×10^{-7}	21	6.4×10^{-8}	0.16	6.0×10^{-9}
U.S. 84/285 to I-25	59	2.5×10^{-7}	21	7.4×10^{-8}	0.16	5.6×10^{-9}
Remainder of New Mexico	59	9.9×10^{-7}	21	1.4×10^{-6}	0.16	1.3×10^{-7}
Rest of U.S.	59	1.1×10^{-5}	NA	NA	NA	NA

TABLE F.6.5.2-2.—Bounding Radioactive Materials Off-Site Accident Population Risk for the No Action Alternative

ROUTE SEGMENT	ANNUAL POPULATION DOSE RISK AND EXCESS LCF RISK						
	SHIPMENT TYPE						
	AMERICIUM-241	CH TRU	RH TRU	PLUTONIUM-238	PITS	TOTAL	
	PERSON-REM/YEAR	PERSON-REM/YEAR	PERSON-REM/YEAR	PERSON-REM/YEAR	PERSON-REM/YEAR	PERSON-REM/YEAR	EXCESS LCF/YEAR
LANL to U.S. 84/285	1.5×10^{-2}	1.4×10^{-3}	3.1×10^{-6}	4×10^{-7}	2×10^{-6}	1.6×10^{-2}	8.0×10^{-6}
U.S. 84/285 to I-25	2.4×10^{-1}	1.9×10^{-2}	4.2×10^{-5}	1×10^{-6}	1×10^{-5}	2.6×10^{-1}	1.3×10^{-4}
Remainder of New Mexico	3.1×10^{-2}	1.2×10^{-2}	2.6×10^{-5}	4×10^{-7}	4×10^{-6}	4.3×10^{-2}	2.2×10^{-5}
Rest of U.S.	2.5×10^0	NA	NA	4×10^{-6}	2×10^{-5}	2.5×10^0	1.2×10^{-3}

TABLE F.6.5.2-3.—Bounding Radioactive Materials Off-Site Accident Population Risk for the Expanded Operations Alternative

ROUTE SEGMENT	ANNUAL POPULATION DOSE RISK AND EXCESS LCF RISK						
	SHIPMENT TYPE						
	AMERICIUM-241	CH TRU	RH TRU	PLUTONIUM-238	PITS	TOTAL	
	PERSON-REM/YEAR	PERSON-REM/YEAR	PERSON-REM/YEAR	PERSON-REM/YEAR	PERSON-REM/YEAR	PERSON-REM/YEAR	EXCESS LCF/YEAR
LANL to U.S. 84/285	1.6×10^{-2}	1.9×10^{-3}	3.8×10^{-6}	1×10^{-6}	6×10^{-6}	1.8×10^{-2}	9.0×10^{-6}
U.S. 84/285 to I-25	2.5×10^{-1}	2.4×10^{-2}	5.3×10^{-5}	2×10^{-6}	2×10^{-5}	2.7×10^{-1}	1.4×10^{-4}
Remainder of New Mexico	3.3×10^{-2}	1.6×10^{-2}	3.3×10^{-5}	1×10^{-6}	8×10^{-6}	4.9×10^{-2}	2.4×10^{-5}
Rest of U.S.	2.7×10^0	NA	NA	8×10^{-6}	4×10^{-5}	2.7×10^0	1.4×10^{-3}

TABLE F.6.5.2-4.—Bounding Radioactive Materials Off-Site Accident Population Risk for the Reduced Operations Alternative

ROUTE SEGMENT	ANNUAL POPULATION DOSE RISK AND EXCESS LCF RISK						
	SHIPMENT TYPE						
	AMERICIUM-241	CH TRU	RH TRU	PLUTONIUM-238	PITS	TOTAL	
	PERSON-REM/ YEAR	PERSON- REM/YEAR	PERSON- REM/YEAR	PERSON-REM/ YEAR	PERSON- REM/YEAR	PERSON- REM/YEAR	EXCESS LCF/YEAR
LANL to U.S. 84/285	1.5×10^{-2}	1.4×10^{-3}	2.9×10^{-6}	4×10^{-7}	2×10^{-6}	1.6×10^{-2}	8.0×10^{-6}
U.S. 84/285 to I-25	2.4×10^{-1}	1.9×10^{-2}	4.0×10^{-5}	1×10^{-6}	8×10^{-6}	2.6×10^{-1}	1.3×10^{-4}
Remainder of New Mexico	3.1×10^{-2}	1.2×10^{-2}	2.5×10^{-5}	4×10^{-7}	4×10^{-6}	4.3×10^{-2}	2.2×10^{-5}
Rest of U.S.	2.5×10^0	NA	NA	4×10^{-6}	1×10^{-5}	2.5×10^0	1.2×10^{-3}

TABLE F.6.5.2-5.—Bounding Radioactive Materials Off-Site Accident Population Risk for the Greener Alternative

ROUTE SEGMENT	ANNUAL POPULATION DOSE RISK AND EXCESS LCF RISK						
	SHIPMENT TYPE						
	AMERICIUM-241	CH TRU	RH TRU	PLUTONIUM-238	PITS	TOTAL	
	PERSON-REM/ YEAR	PERSON- REM/YEAR	PERSON- REM/YEAR	PERSON-REM/ YEAR	PERSON- REM/YEAR	PERSON- REM/YEAR	EXCESS LCF/YEAR
LANL to U.S. 84/285	1.6×10^{-2}	1.5×10^{-3}	3.2×10^{-6}	4×10^{-7}	2×10^{-6}	1.8×10^{-2}	9.0×10^{-6}
U.S. 84/285 to I-25	2.5×10^{-1}	2.0×10^{-2}	4.4×10^{-5}	1×10^{-6}	8×10^{-6}	2.7×10^{-1}	1.4×10^{-4}
Remainder of New Mexico	3.3×10^{-2}	1.3×10^{-2}	2.7×10^{-5}	4×10^{-7}	4×10^{-6}	4.6×10^{-2}	2.3×10^{-5}
Rest of U.S.	2.7×10^0	NA	NA	4×10^{-6}	1×10^{-5}	2.7×10^0	1.4×10^{-3}

TABLE F.6.5.3-1.—Exposure Parameters of Bounding Chlorine Accident

ACCIDENT DESCRIPTION	MAXIMUM EXPOSURE DURATION (MINUTES)	MAXIMUM DOWNWIND DISTANCE (KILOMETERS)		MAXIMUM CLOUD WIDTH (KILOMETERS)	
		EPRG-2	EPRG-3	EPRG-2	EPRG-3
Fire Causes Opening of a Fusible Plug	8.4	4.2	2.1	0.28	0.15

EPRG = Emergency Response Planning Guideline

(NSC 1995) was used to estimate release rates from the 1-ton (908-kilogram) container, and the DEGADIS (Havens and Spicer 1985) dense gas dispersion model was used to predict downwind chlorine concentrations following the four postulated releases. (A separate version of DEGADIS is used because the version incorporated in ALOHA does not readily provide time variation of downwind concentrations.)

In this analysis, exposures to toxic chemicals are compared to Emergency Response Planning Guidelines (ERPGs). ERPGs are explained in detail in appendix G, section G.2.2. ERPG-2 is the maximum airborne concentration below which it is believed that nearly all individuals could be exposed for up to 1 hour without experiencing or developing irreversible or other serious health effects or symptoms that could impair their abilities to take protective action. ERPG-3 is the maximum airborne concentration below which it is believed that nearly all individuals could be exposed for up to 1 hour without experiencing or developing life-threatening health effects. The model predicts the length and width of the cloud for which concentrations are greater than those at ERPG-2 and ERPG-3. The area affected, the maximum exposure duration, the maximum downwind distance affected, and the maximum chlorine cloud width are shown in Table F.6.5.3-1 for the bounding release, which is release from a small hole with fire. (Catastrophic releases are of very short duration and a high escape fraction is likely.)

The number of fatalities or injuries would depend on the population density and the ability of people to avoid harmful exposure by going indoors or leaving the affected area. The frequency of occurrence of this accident would depend on the truck accident rate. The accident rate and population density would vary for the different route segments. The ability of people to avoid harmful exposure (to escape) would depend on various factors; an escape fraction of 0.98 is used for all route segments. This fraction

is based on analysis of a transportation accident producing fatal releases of ammonia (Glickman and Raj 1992) and should be applicable to chlorine because the same dispersion coefficients apply, resulting in similar plume shapes and gradients of concentration. For both, there will be objectionable odor a short period prior to concentrations that have serious effects. The plumes tend to be visible and of modest transverse dimension, with very objectionable odor and strong respiratory irritation at their edges, permitting recognition and urging prompt escape on foot. The estimated frequency of a major chlorine release and the estimated number of associated fatalities and injuries are given in Table F.6.5.3-2 for different population densities along the routes. The risk values (i.e., annual frequency times consequences analogous to Tables F.6.5.2-2 through F.6.5.2-5) are given for the SWEIS alternatives in Table F.6.5.3-3.

F.6.5.4 *Analysis of Accidents Producing Propane Releases*

The bounding consequence from a propane release would be the generation of a fireball. The fireball would likely occur too soon after the postulated truck accident for evacuation to be effective. The fireball would have a radius of about 148 feet (45 meters) and would burn for about 3 seconds. Many persons would be protected by buildings or automobiles for this short duration. It is assumed that 50 percent of the available population would be shielded from the fireball, 10 percent would be fatalities, and the remainder would be injured (PNL 1980). In addition, fatal second-degree burns might be experienced out to a radius of 620 feet (189 meters). The percentages of available persons that would be exposed to the radiant heat flux are assumed to be 0.16 percent, 12 percent, and 19 percent in urban, suburban, and rural areas, respectively (PNL 1980).

TABLE F.6.5.3–2.—Frequencies and Consequences of a Major Chlorine Release

ROUTE SEGMENT	AREA	FREQUENCY PER TRIP	ESTIMATED NUMBER OF FATALITIES	ESTIMATED NUMBER OF INJURIES
LANL to U.S. 84/285	Rural	3.1×10^{-7}	6.5×10^{-2}	2.4×10^{-1}
	Suburban	5.1×10^{-8}	1.5×10^0	5.6×10^0
U.S. 84/285 to I–25	Rural	2.4×10^{-7}	5.3×10^{-2}	2.0×10^{-1}
	Suburban	5.2×10^{-7}	3.0×10^0	1.1×10^1
	Urban	1.6×10^{-7}	1.1×10^1	4.0×10^1
Remainder of New Mexico	Rural	1.8×10^{-6}	1.5×10^{-2}	5.6×10^{-2}
	Suburban	1.9×10^{-7}	1.5×10^0	5.5×10^0
	Urban	3.1×10^{-8}	8.4×10^0	3.2×10^1
Remainder of U.S.	Rural	1.3×10^{-5}	2.8×10^{-2}	1.0×10^{-1}
	Suburban	3.3×10^{-6}	1.6×10^0	6.1×10^0
	Urban	7.8×10^{-7}	1.0×10^1	3.9×10^1

TABLE F.6.5.3–3.—Major Chlorine Accident Risks

ROUTE SEGMENT	ALTERNATIVE							
	NO ACTION		EXPANDED OPERATIONS		REDUCED OPERATIONS		GREENER	
	FATALITIES PER YEAR	INJURIES PER YEAR	FATALITIES PER YEAR	INJURIES PER YEAR	FATALITIES PER YEAR	INJURIES PER YEAR	FATALITIES PER YEAR	INJURIES PER YEAR
LANL to U.S. 84/285	8.6×10^{-6}	3.2×10^{-5}	1.9×10^{-5}	7.2×10^{-5}	8.0×10^{-6}	3.0×10^{-5}	8.6×10^{-6}	3.2×10^{-5}
U.S. 84/285 to I–25	2.9×10^{-4}	1.1×10^{-3}	6.4×10^{-4}	2.4×10^{-3}	2.7×10^{-4}	1.0×10^{-3}	2.9×10^{-4}	1.1×10^{-3}
Remainder of New Mexico	5.2×10^{-5}	1.9×10^{-4}	1.1×10^{-4}	4.2×10^{-4}	4.8×10^{-5}	1.8×10^{-4}	5.2×10^{-5}	1.9×10^{-4}
Remainder of U.S.	1.2×10^{-3}	4.7×10^{-3}	2.8×10^{-3}	1.0×10^{-2}	1.2×10^{-3}	4.4×10^{-3}	1.2×10^{-3}	4.7×10^{-3}

The number of fatalities or injuries would depend on the population density and the ability of people to avoid harmful exposure by going indoors or leaving the affected area. The frequency of occurrence of this accident would depend on the truck accident rate. The accident rate and population density would vary for the different route segments. The ability of people to avoid harmful exposure (to escape) would depend on various factors; an escape fraction of 0.98 is used for all route segments. This fraction is based on analysis of a transportation accident producing fatal releases of ammonia (Glickman and Raj 1992) and should be applicable to chlorine because the same dispersion coefficients apply, resulting in similar plume shapes and gradients of concentration. For both, there will be objectionable odor a short period prior to concentrations that have serious effects. The plumes tend to be visible and of modest transverse dimension, with very objectionable odor and strong respiratory irritation at their edges, permitting recognition and urging prompt escape on foot. The estimated frequency of a major chlorine release and the estimated number of associated fatalities and injuries are given in Table F.6.5.3–2 for different population densities along the routes. The risk values (i.e., annual frequency times consequences analogous to Tables F.6.5.2–2 through F.6.5.2–5) are given for the SWEIS alternatives in Table F.6.5.3–3.

F.6.5.4 *Analysis of Accidents Producing Propane Releases*

The bounding consequence from a propane release would be the generation of a fireball. The fireball would likely occur too soon after the postulated truck accident for evacuation to be effective. The fireball would have a radius of about 148 feet (45 meters) and would burn for about 3 seconds. Many persons would be protected by buildings or automobiles for this short duration. It is assumed that 50 percent of

the available population would be shielded from the fireball, 10 percent would be fatalities, and the remainder would be injured (PNL 1980). In addition, fatal second-degree burns might be experienced out to a radius of 620 feet (189 meters). The percentages of available persons that would be exposed to the radiant heat flux are assumed to be 0.16 percent, 12 percent, and 19 percent in urban, suburban, and rural areas, respectively (PNL 1980).

The number of persons that would be affected depends on the population density; the frequency of the accident would depend on the truck accident rate. Both of these parameters would vary for the different route segments. The truck accident frequency of a major propane release and the estimated numbers of fatalities and injuries are given in Table F.6.5.4–1 for different population densities along the routes. The fatality and injury risks are given in Table F.6.5.4–2 for the four SWEIS alternatives. The frequency of large explosive shipments was added to the frequency of large flammable shipments.

F.6.5.5 *Analysis of On-Site Accidents Producing Bounding Radioactive Materials Releases*

The bounding on-site shipments involving RAM are the transport of plutonium-238 solution from CMR to TA–55 and the transport of irradiated targets from the LANSCE to TA–48. Both types of shipments are made with the roads closed to all persons except personnel directly involved in the transport. Therefore, no member of the public would be expected to be involved in the postulated truck accident or to be a bystander after the postulated truck accident.

MEI dose is calculated using the following assumptions. In the case of plutonium-238 solution, it is assumed that a person would stand very close to the evaporating liquid for 10 minutes before being warned away. In the case

TABLE F.6.5.4-1.—Frequencies and Consequences of a Major Propane Release

ROUTE SEGMENT	AREA	FREQUENCY PER TRIP	ESTIMATED NUMBER OF FATALITIES	ESTIMATED NUMBER OF INJURIES
LANL to U.S. 84/285	Rural	1.3×10^{-7}	2.8×10^{-1}	1.1×10^0
	Suburban	2.2×10^{-8}	4.2×10^0	1.7×10^1
U.S. 84/285 to I-25	Rural	1.0×10^{-7}	2.3×10^{-1}	9.2×10^{-1}
	Suburban	2.2×10^{-7}	8.4×10^0	3.4×10^1
	Urban	6.7×10^{-8}	1.8×10^0	7.3×10^0
Remainder of New Mexico	Rural	8.7×10^{-7}	1.5×10^{-1}	6.0×10^{-1}
	Suburban	2.8×10^{-7}	5.1×10^0	2.0×10^1
	Urban	3.5×10^{-8}	1.5×10^0	6.1×10^0
Remainder of U.S.	Rural	1.1×10^{-6}	9.0×10^{-2}	3.6×10^{-1}
	Suburban	1.4×10^{-7}	4.8×10^0	1.9×10^1
	Urban	7.2×10^{-8}	1.9×10^0	7.5×10^0

TABLE F.6.5.4-2.—Major Propane Accident Risk

ROUTE SEGMENT	ALTERNATIVE							
	NO ACTION		EXPANDED OPERATIONS		REDUCED OPERATIONS		GREENER	
	FATALITIES PER YEAR	INJURIES PER YEAR	FATALITIES PER YEAR	INJURIES PER YEAR	FATALITIES PER YEAR	INJURIES PER YEAR	FATALITIES PER YEAR	INJURIES PER YEAR
LANL to U.S. 84/285	9.7×10^{-6}	3.9×10^{-5}	2.2×10^{-5}	8.6×10^{-5}	9.2×10^{-6}	3.7×10^{-5}	9.7×10^{-6}	3.9×10^{-5}
U.S. 84/285 to I-25	1.5×10^{-4}	6.0×10^{-4}	3.3×10^{-4}	1.3×10^{-3}	1.4×10^{-4}	5.7×10^{-4}	1.5×10^{-4}	6.0×10^{-4}
Remainder of New Mexico	1.2×10^{-4}	4.8×10^{-4}	2.6×10^{-4}	1.1×10^{-3}	1.1×10^{-4}	4.5×10^{-4}	1.2×10^{-4}	4.8×10^{-4}
Remainder of U.S.	6.7×10^{-5}	2.7×10^{-4}	1.5×10^{-4}	5.9×10^{-4}	6.3×10^{-5}	2.5×10^{-4}	6.7×10^{-5}	2.7×10^{-4}

of the irradiated target cask failure, a narrow radiation beam would be produced that would be lethal after 10 minutes of continuous exposure at a distance of 6 feet (1.8 meters) from the cask, and it is assumed that a person would stand in this beam for 10 minutes.

The resulting MEI doses and frequencies are given in Table F.6.5.5–1, and MEI risk is given in Table F.6.5.5–2 for the four SWEIS alternatives. The plutonium-238 solution sample shipment frequency terms includes weapons-grade plutonium solution sample shipments, and the irradiated target shipment frequency term includes activated inserts and beam stops (Table F.5.3–2) shipments. DARHT shipment accidents could result in an off-site MEI dose of 76 rem and fatalities to LANL truck crews and other individuals within 80 feet (24 meters) of the explosion (DOE 1995). The frequency of DARHT shipments has been added to the frequency of irradiated target shipments.

F.6.6 Transportation of Waste Off Site

Transportation of waste is imbedded in the transportation risk assessment. Because the methodology is directed at identifying the greatest risks associated with shipments of materials, both from the standpoint of incident-free shipments as well as accidents, the lesser quantities of materials per package typically found in wastes (as compared to stock materials) tend to screen them from a detailed analytical presentation in this assessment. Waste shipments have been found to be of public interest; and it is useful, therefore, to discuss the manner in which the impacts of these shipments are considered. This qualitative presentation is also illustrative of the overall methodology.

Numbers of shipments of waste per year in the categories of radioactive and nonradioactive hazardous material were included in the mileage calculations for shipment of other materials in the same class for the purpose of evaluating impacts due to vehicle emissions, direct

TABLE F.6.5.5–1.—Maximally Exposed Individual Doses and Frequencies for On-Site Radioactive Materials Accidents

SHIPMENT TYPE	PER TRIP FREQUENCY	MEI DOSE
Plutonium-238 Solution	6.9×10^{-10}	8.7 rem
Irradiated Targets	3.4×10^{-8}	fatal

TABLE F.6.5.5–2.—On-Site Radioactive Materials Accident Maximally Exposed Individual Risk

SHIPMENT TYPE	MEI RISK PER ALTERNATIVE			
	NO ACTION	EXPANDED OPERATIONS	REDUCED OPERATIONS	GREENER
Plutonium-238 Solution	7.7×10^{-7} rem/year (3.1×10^{-10} excess LCF/year)	1.4×10^{-6} rem/year (5.8×10^{-10} excess LCF/year)	7.7×10^{-7} rem/year (3.1×10^{-10} excess LCF/year)	7.7×10^{-7} rem/year (3.1×10^{-10} excess LCF/year)
Irradiated Targets	3.1×10^{-6} fatalities/year	3.2×10^{-6} fatalities/year	2.9×10^{-6} fatalities/year	3.2×10^{-6} fatalities/year

exposure to radiation, and accidents not involving the release of cargo. Specifically, TRU waste shipments to WIPP are less than 10 percent of the total number of shipments under any alternative (and because of the relatively short distance between LANL and WIPP, these shipments would constitute an even smaller percentage contribution to incident-free impacts attributed to radioactive material shipments), LLW shipments for off-site disposal under the Reduced Operations and Greener Alternatives are about 30 percent of the total shipments under these alternatives (LLW constitutes about 15 percent and less than 1 percent of off-site shipments under the No Action and Expanded Operations Alternatives, respectively), and about 10 percent of the total number of hazardous (nonradioactive) shipments would be expected to be waste shipments. (This is based on historical information—hazardous waste shipments were not specifically projected and are not reflected as individual shipments in the off-site shipment projections in this appendix.) Although the numbers of hazardous waste shipments were not individually projected, they are included in the numbers of shipments in Table F.5.3–3 and considered in the total mileage and impacts projected for hazardous material shipments.

Routes for the shipment of waste are typical of, and represented by, the routes chosen for analysis that covered the U.S. by sector in terms of population density as well as the category of road (except that WIPP shipment routes, as noted above, are much shorter than most of the nonwaste radioactive material shipment routes); thus, the contribution of waste shipments to the total risks due to vehicle emissions and accidents without a cargo release could be estimated using the percentages in the previous paragraph (although this would be very conservative for WIPP shipments). The amount of material in a given container is orders of magnitude less for waste shipments than for product shipments (see accidents discussion below), so the incident-free radiation exposure

attributable to waste shipments would be a very small percentage of that presented in this appendix and in chapter 5.

Accidents involving the release of cargo were based on factors such as the greatest quantity of the material known to be shipped, the most toxic, and the least protective packaging. Accident risk associated with the transportation of transuranic waste to WIPP was specifically analyzed and presented in this appendix and in chapter 5 due to public interest in such shipments, and they are not discussed further here. LLW and low-level mixed waste (LLMW) shipments involve, at most, from 0.001 percent (for plutonium-238) to 0.01 percent (for americium-241 and plutonium-239) of the total material considered in the off-site radioactive materials accidents specifically presented in this appendix. The mileage associated with LLW waste shipments is conservatively estimated at 30 percent of that used in the radioactive materials accident analyses presented in this appendix. Therefore, the risk associated with waste shipments is conservatively estimated to be 0.003 percent of that analyzed and presented for radioactive materials, as presented in this analysis.

Similarly, shipments of hazardous chemical (nonradioactive) waste contain much less of the hazardous material content than do the shipments of chlorine and propane analyzed and presented in this appendix and in chapter 5. While no estimates of waste contents were available for use in this SWEIS, such shipments would not be likely to exceed 10 percent of the amounts used for chlorine and propane accidents (and would likely be a much smaller fraction of these quantities). On that basis, hazardous chemical waste shipments, which constitute about 10 percent of the total number of hazardous chemical shipments, would not be expected (conservatively) to result in risks that exceed 1 percent of those presented in this SWEIS for hazardous material shipments.

F.7 ANALYSIS OF THE SANTA FE RELIEF ROUTE OPTION

F.7.1 Introduction

The effect of the proposed relief route would be to replace 6.5 miles (10.5 kilometers) on U.S. 84/285 through Santa Fe to exit number 282 of I-25 with 13.8 miles (22.2 kilometers) starting from U.S. 84/285 north of Santa Fe to exit number 276 of I-25, south of Santa Fe. Because of the location where the Relief Route meets I-25, travel on I-25 south of Santa Fe would be reduced by six miles of highway travel, and travel on I-25 north of Santa Fe would be increased by 6 miles of highway travel if the Relief Route were used. The route between exit number 282 of I-25 and the junction of U.S. 84/285 with NM 502 consists of 1.2 miles (1.9 kilometers) of urban, 3.9 miles (1.9 kilometers) of suburban, and 14.9 miles (24 kilometers) of rural highway (Table F.4.3-1). For this analysis, the 6.5 mile (10.5 kilometer) segment replaced is assumed to consist of all of the urban and suburban highway plus 1.4 miles (2.3 kilometers) of rural highway. The 13.8-mile (22.2-kilometer) relief route is assumed to consist of 9.6 miles (15.4 kilometers) of suburban and 4.2 miles (6.8 kilometers) of rural highway.

The four risk measures evaluated in section F.6 are evaluated in this section for the relief route option.

F.7.2 Results

The effect of the proposed relief route on truck emissions in urban areas would be to eliminate 1.2 miles (1.9 kilometers) of urban highway. The overall reduction in excess LCFs would be small, as shown in Table F.7.2-1.

A comparison of the annual number of fatalities and injuries from truck accidents is shown in Tables F.7.2-2 and F.7.2-3, respectively. The

variation in truck accidents is shown in Table F.7.2-4.

Only the route segments affected by the relief route option are described. The effect of the relief route on the remainder of New Mexico route segment is negligible, but the effect on the U.S. 84/285 to I-25 route segment is reduced by about one-half for the relief route option. The reason is that the accident rate assumed on the relief route is approximately one order of magnitude less than that for some parts of the route through Santa Fe, in contrast to the distance which increases by 50 percent.

A comparison of the annual incident-free population doses for the No Action, Expanded Operations, Reduced Operations, and Greener Alternatives is given in Tables F.7.2-5 through F.7.2-8, respectively. In general, the changes are small with a few exceptions. The occupational and stops doses are directly proportional to the length and inversely proportional to the truck speed, and they increase for the relief route. The dose to those sharing the route is directly proportional to the traffic density, which is significantly reduced on the relief route. This dose decreases for the relief route.

A comparison of the change in accident frequencies is shown in Tables F.7.2-9 and F.7.2-10 for radioactive and HAZMAT, respectively. The change in the remainder of New Mexico route segment depends on whether the shipment direction is southwest or northeast. Chlorine is the representative material for all toxic materials, whose representative source is the northeast; and propane is the representative material for all flammable materials, whose representative source is the southwest. (The comment in the next paragraph about potential exaggeration applies to Tables F.7.2-9 and F.7.2-10.)

The changes in bounding RAM accident population dose risks are shown in Tables F.7.2-11 through F.7.2-14 for the four SWEIS

TABLE F.7.2-1.—Comparison of Excess Latent Cancer Fatalities per Year Due to Truck Emissions

ROUTE OPTION	ALTERNATIVE			
	NO ACTION	EXPANDED OPERATIONS	REDUCED OPERATIONS	GREENER
Route Through Santa Fe	3.2×10^{-2}	6.6×10^{-2}	3.4×10^{-2}	3.6×10^{-2}
Relief Route	3.1×10^{-2}	6.4×10^{-2}	3.3×10^{-2}	3.5×10^{-2}

TABLE F.7.2-2.—Comparison of Annual Truck Accident Fatalities

ROUTE OPTION	ROUTE SEGMENT	ALTERNATIVE			
		NO ACTION	EXPANDED OPERATIONS	REDUCED OPERATIONS	GREENER
Route Through Santa Fe	U.S. 84/285 to I-25	4.1×10^{-3}	8.2×10^{-3}	4.3×10^{-3}	4.6×10^{-3}
	Remainder of New Mexico	7.2×10^{-2}	1.5×10^{-1}	7.5×10^{-2}	8.0×10^{-2}
Relief Route	U.S. 84/285 and Relief Route	2.3×10^{-3}	4.7×10^{-3}	2.4×10^{-3}	2.6×10^{-3}
	Remainder of New Mexico	7.2×10^{-2}	1.5×10^{-1}	7.6×10^{-2}	8.1×10^{-2}

TABLE F.7.2-3.—Comparison of Annual Truck Accident Injuries

ROUTE OPTION	ROUTE SEGMENT	ALTERNATIVE			
		NO ACTION	EXPANDED OPERATIONS	REDUCED OPERATIONS	GREENER
Route Through Santa Fe	U.S. 84/285 to I-25	8.6×10^{-2}	1.8×10^{-1}	9.1×10^{-2}	9.7×10^{-2}
	Remainder of New Mexico	6.4×10^{-1}	1.3×10^0	6.8×10^{-1}	7.2×10^{-1}
Relief Route	U.S. 84/285 to I-25	4.9×10^{-2}	9.8×10^{-2}	5.2×10^{-2}	5.5×10^{-2}
	Remainder of New Mexico	6.5×10^{-1}	1.3×10^0	6.8×10^{-1}	7.3×10^{-1}

TABLE F.7.2-4.—Comparison of Number of Annual Truck Accidents

ROUTE OPTION	ROUTE SEGMENT	ALTERNATIVE			
		NO ACTION	EXPANDED OPERATIONS	REDUCED OPERATIONS	GREENER
Route Through Santa Fe	U.S. 84/285 to I-25	4.1×10^{-1}	8.2×10^{-1}	4.3×10^{-1}	4.6×10^{-1}
	Remainder of New Mexico	6.7×10^{-1}	1.4×10^0	7.0×10^{-1}	7.6×10^{-1}
Relief Route	U.S. 84/285 to I-25	2.3×10^{-1}	4.7×10^{-1}	2.4×10^{-1}	2.6×10^{-1}
	Remainder of New Mexico	6.7×10^{-1}	1.4×10^0	7.1×10^{-1}	7.6×10^{-1}

TABLE F.7.2-5.—Comparison of Annual Incident-Free Population Dose for the No Action Alternative

ROUTE OPTION	ROUTE SEGMENT	OCCUPATIONAL (PERSON-REM/ YEAR)	NONOCCUPATIONAL (PERSON-REM/YEAR)		
			ALONG ROUTE	SHARING ROUTE	STOPS
Route Through Santa Fe	U.S. 84/285 to I-25	7.9×10^0	3.8×10^{-1}	3.6×10^0	3.3×10^0
	Remainder of New Mexico	4.5×10^1	1.0×10^{-1}	1.7×10^0	2.4×10^1
Relief Route	U.S. 84/285 to I-25	1.1×10^1	3.8×10^{-1}	2.2×10^0	4.8×10^0
	Remainder of New Mexico	4.5×10^1	1.2×10^{-1}	1.7×10^0	2.4×10^1

TABLE F.7.2-6.—Comparison of Annual Incident-Free Population Dose for the Expanded Operations Alternative

ROUTE OPTION	ROUTE SEGMENT	OCCUPATIONAL (PERSON-REM/ YEAR)	NONOCCUPATIONAL (PERSON-REM/YEAR)		
			ALONG ROUTE	SHARING ROUTE	STOPS
Route Through Santa Fe	U.S. 84/285 to I-25	1.0×10^1	4.9×10^{-1}	4.6×10^0	4.2×10^0
	Remainder of New Mexico	5.5×10^1	1.2×10^{-1}	2.1×10^0	3.0×10^1
Relief Route	U.S. 84/285 to I-25	1.5×10^1	4.8×10^{-1}	2.8×10^0	6.1×10^0
	Remainder of New Mexico	5.5×10^1	1.3×10^{-1}	2.1×10^1	3.0×10^1

TABLE F.7.2-7.—Comparison of Annual Incident-Free Population Dose for the Reduced Operations Alternative

ROUTE OPTION	ROUTE SEGMENT	OCCUPATIONAL (PERSON-REM/ YEAR)	NONOCCUPATIONAL (PERSON-REM/YEAR)		
			ALONG ROUTE	SHARING ROUTE	STOPS
Route Through Santa Fe	U.S. 84/285 to I-25	8.7×10^0	4.2×10^{-1}	3.4×10^0	3.6×10^0
	Remainder of New Mexico	5.0×10^1	1.2×10^{-1}	1.9×10^0	2.7×10^1
Relief Route	U.S. 84/285 to I-25	1.2×10^1	4.1×10^{-1}	2.4×10^0	5.2×10^0
	Remainder of New Mexico	5.1×10^1	1.3×10^{-1}	1.9×10^0	2.7×10^1

TABLE F.7.2-8.—Comparison of Annual Incident-Free Population Dose for the Greener Alternative

ROUTE OPTION	ROUTE SEGMENT	OCCUPATIONAL (PERSON-REM/ YEAR)	NONOCCUPATIONAL (PERSON-REM/YEAR)		
			ALONG ROUTE	SHARING ROUTE	STOPS
Route Through Santa Fe	U.S. 84/285 to I-25	9.2×10^0	4.4×10^{-1}	4.2×10^0	3.8×10^0
	Remainder of New Mexico	5.2×10^1	1.3×10^{-1}	2.0×10^0	2.8×10^1
Relief Route	U.S. 84/285 to I-25	1.3×10^1	4.8×10^{-1}	2.5×10^0	5.5×10^0
	Remainder of New Mexico	5.3×10^1	1.3×10^{-1}	2.0×10^0	2.9×10^1

TABLE F.7.2-9.—Comparison of Off-Site Radioactive Materials Release Frequencies

ROUTE OPTION	ROUTE SEGMENT	FREQUENCY PER TRIP		
		AMERICIUM- 241	CH TRU	RH TRU
Route Through Santa Fe	U.S. 84/285 to I-25	2.5×10^{-7}	7.4×10^{-8}	5.6×10^{-9}
	Remainder of New Mexico	9.9×10^{-7}	1.4×10^{-6}	1.3×10^{-7}
Relief Route	U.S. 84/285 to I-25	2.0×10^{-7}	6.8×10^{-8}	6.1×10^{-9}
	Remainder of New Mexico	1.0×10^{-6}	1.4×10^{-6}	1.3×10^{-7}

TABLE F.7.2-10.—Comparison of Chlorine and Propane Major Release Frequencies

ROUTE OPTION	ROUTE SEGMENT	FREQUENCY PER TRIP	
		CHLORINE	PROPANE
Route Through Santa Fe	U.S. 84/285 to I-25	9.1×10^{-7}	3.9×10^{-7}
	Remainder of New Mexico	2.0×10^{-6}	1.2×10^{-6}
Relief Route	U.S. 84/285 to I-25	4.6×10^{-7}	2.0×10^{-7}
	Remainder of New Mexico	2.3×10^{-6}	1.1×10^{-6}

TABLE F.7.2-11.—Comparison of Bounding Radioactive Material Off-Site Accident Population Risk for the No Action Alternative

ROUTE OPTION	ROUTE SEGMENT	POPULATION RISK (PERSON-REM/YEAR) FOR SHIPMENT TYPES					TOTAL	
		AMERICIUM -241	CH TRU	RH TRU	PLUTONIUM -238	PITS	PERSON-REM/YEAR	EXCESS LCF/YEAR
Route Through Santa Fe	U.S. 84/285 to I-25	2.4×10^{-1}	1.9×10^{-2}	4.2×10^{-5}	1×10^{-6}	1×10^{-5}	2.6×10^{-1}	1.3×10^{-4}
	Remainder of New Mexico	3.1×10^{-2}	1.2×10^{-2}	2.6×10^{-5}	4×10^{-7}	4×10^{-6}	4.3×10^{-2}	2.2×10^{-5}
Relief Route	U.S. 84/285 to I-25	6.8×10^{-2}	5.6×10^{-3}	1.2×10^{-5}	4×10^{-7}	4×10^{-6}	7.4×10^{-2}	3.7×10^{-5}
	Remainder of New Mexico	8.4×10^{-2}	1.9×10^{-2}	4.2×10^{-5}	4×10^{-7}	4×10^{-6}	1.0×10^{-1}	5.0×10^{-5}

TABLE F.7.2-12.—Comparison of Bounding Radioactive Materials Off-Site Accident Population Risk for the Expanded Operations Alternative

ROUTE OPTION	ROUTE SEGMENT	POPULATION RISK (PERSON-REM/YEAR) FOR SHIPMENT TYPES					TOTAL	
		AMERICIUM -241	CH TRU	RH TRU	PLUTONIUM-238	PITS	PERSON-REM/YEAR	EXCESS LCF/YEAR
Route Through Santa Fe	U.S. 84/285 to I-25	2.5×10^{-1}	2.4×10^{-2}	5.3×10^{-5}	2×10^{-6}	2×10^{-5}	2.7×10^{-1}	1.4×10^{-4}
	Remainder of New Mexico	3.3×10^{-2}	1.6×10^{-2}	3.3×10^{-5}	1×10^{-6}	8×10^{-6}	4.9×10^{-2}	2.4×10^{-5}
Relief Route	U.S. 84/285 to I-25	7.3×10^{-2}	7.3×10^{-3}	1.5×10^{-5}	1×10^{-6}	8×10^{-6}	8.0×10^{-2}	4.0×10^{-5}
	Remainder of New Mexico	9.0×10^{-2}	2.5×10^{-2}	4.9×10^{-5}	1×10^{-6}	8×10^{-6}	1.2×10^{-1}	6.0×10^{-5}

TABLE F.7.2-13.—Comparison of Bounding Radioactive Materials Off-Site Accident Population Risk for the Reduced Operations Alternative

ROUTE OPTION	ROUTE SEGMENT	POPULATION RISK (PERSON-REM/YEAR) FOR SHIPMENT TYPES						TOTAL	
		AMERICIUM-241	CH TRU	RH TRU	PLUTONIUM-238	PITS	PERSON-REM/YEAR	EXCESS LCF/YEAR	
Route Through Santa Fe	U.S. 84/285 to I-25	2.4×10^{-1}	1.9×10^{-2}	4.0×10^{-5}	1×10^{-6}	8×10^{-6}	2.6×10^{-1}	1.3×10^{-4}	
	Remainder of New Mexico	3.1×10^{-2}	1.2×10^{-2}	2.5×10^{-5}	4×10^{-7}	4×10^{-6}	4.3×10^{-2}	2.2×10^{-5}	
Relief Route	U.S. 84/285 to I-25	6.8×10^{-2}	5.6×10^{-3}	1.2×10^{-5}	4×10^{-7}	2×10^{-6}	7.4×10^{-2}	3.7×10^{-5}	
	Remainder of New Mexico	8.4×10^{-2}	1.9×10^{-2}	4.0×10^{-5}	4×10^{-7}	4×10^{-6}	1.0×10^{-1}	5.0×10^{-5}	

TABLE F.7.2-14.—Comparison of Bounding Radioactive Materials Off-Site Accident Population Risk for the Greener Alternative

ROUTE OPTION	ROUTE SEGMENT	POPULATION RISK (PERSON-REM/YEAR) FOR SHIPMENT TYPES						TOTAL	
		AMERICIUM-241	CH TRU	RH TRU	PLUTONIUM-238	PITS	PERSON-REM/YEAR	EXCESS LCF/YEAR	
St. Francis Drive	U.S. 84/285 to I-25	2.5×10^{-1}	2.0×10^{-2}	4.4×10^{-5}	1×10^{-6}	8×10^{-6}	2.7×10^{-1}	1.4×10^{-4}	
	Remainder of New Mexico	3.3×10^{-2}	1.3×10^{-2}	2.7×10^{-5}	4×10^{-7}	4×10^{-6}	4.6×10^{-2}	2.3×10^{-5}	
Relief Route	U.S. 84/285 to I-25	7.3×10^{-2}	5.9×10^{-3}	1.3×10^{-5}	4×10^{-7}	2×10^{-6}	7.9×10^{-2}	4.0×10^{-5}	
	Remainder of New Mexico	9.0×10^{-2}	2.0×10^{-2}	4.3×10^{-5}	4×10^{-7}	4×10^{-6}	1.1×10^{-1}	5.5×10^{-5}	

alternatives. The change in injury and fatality risks of major releases of chlorine and propane is shown in Tables F.7.2–15 through F.7.2–18 for the four SWEIS alternatives. The RADTRAN results in Tables F.7.2–11 through F.7.2–14 show a major increase for the remainder of New Mexico route segment, but the ADROIT results show no change. The difference in these sets of results is due to the difference in the way the portion of I–25 between exits 276 and 282 was modeled in the two computer programs. All of the RAM shipments analyzed in Tables F.7.2–11 through F.7.2–14, as well as chlorine shipments in Tables F.7.2–15 through F.7.2–18, are expected to follow I–25 north for 6 miles further with the relief route option than for the route through Santa Fe, in contrast to propane shipments that would go south on I–25 and experience 6 miles less travel on I–25. The RADTRAN, chlorine, and propane analyses are based on the conservative assumption that the 6 miles on I–25 are in an area with a population density characteristic of suburban areas. The changes in the remainder of New Mexico values for americium-241, CH TRU, RH TRU, chlorine, and propane are therefore somewhat exaggerated. The changes for the 6 miles on I–25 are accurately computed in the ADROIT analysis of plutonium-238 and pits, but are tabulated in the U.S. 84/285 to I–25 route segment rather than the remainder of New Mexico route segment. The ADROIT computer code has the capability to access population data at the census block level.

F.8 UNCERTAINTY AND CONSERVATISM IN THE ANALYSIS

The major steps in the transportation risk analysis are as follows:

- Determination of the amount and characteristics of materials that will be needed or generated and thus moved to or from the LANL site.
- Estimation of the amount per shipment (e.g., packaging requirements and efficiency of truck capacity utilization, which may conflict with other logistics considerations such as storage requirements until a truck can be filled).
- Determination of the bounding material in a category and the number of shipments of this and similar materials that should be aggregated for frequency analysis.
- Selection of appropriate origin and destination and determination of the route and its characteristic population, accident rate, etc.
- Estimation of package release probabilities.
- Estimation of the amount released from the packaging and the fraction airborne that is respirable.
- Calculation of dispersion, exposure, and health effect.

Uncertainties are associated with each step. The overall approach to dealing with uncertainty is to estimate conservative values for parameters and to estimate consistently. On the other hand, estimates are not knowingly chosen to be conservative by orders of magnitude because that approach could obscure differences between alternatives. The focus of this analysis was on shipments that could contribute significantly to the transportation risk. The total number of shipments is important, as are the shipments of large amounts of dispersible and toxic material. The following subsections contain descriptions of sources of uncertainty and the resulting conservatism for each of the major analysis steps. Emphasis is placed on uncertainty unique to the SWEIS.

F.8.1 Material Amount and Characterization

Because a detailed analysis of every type of LANL shipment would be impractical, shipments of similar types were aggregated on the basis of the most hazardous material.

TABLE F.7.2–15.—Comparison of Major Chlorine and Propane Accident Risks for the No Action Alternative

ROUTE OPTION	ROUTE SEGMENT	CHLORINE		PROPANE	
		FATALITIES PER YEAR	INJURIES PER YEAR	FATALITIES PER YEAR	INJURIES PER YEAR
Route Through Santa Fe	U.S. 84/285 to I-25	2.9×10^{-4}	1.1×10^{-3}	1.5×10^{-4}	6.0×10^{-4}
	Remainder of New Mexico	5.2×10^{-5}	1.9×10^{-4}	1.2×10^{-4}	4.8×10^{-4}
Relief Route	U.S. 84/285 to I-25	4.2×10^{-5}	1.6×10^{-4}	4.4×10^{-5}	1.7×10^{-4}
	Remainder of New Mexico	8.4×10^{-5}	3.2×10^{-4}	7.4×10^{-5}	3.0×10^{-4}

TABLE F.7.2–16.—Comparison of Major Chlorine and Propane Accident Risks for the Expanded Operations Alternative

ROUTE OPTION	ROUTE SEGMENT	CHLORINE		PROPANE	
		FATALITIES PER YEAR	INJURIES PER YEAR	FATALITIES PER YEAR	INJURIES PER YEAR
Route Through Santa Fe	U.S. 84/285 to I-25	6.4×10^{-4}	2.4×10^{-3}	3.3×10^{-4}	1.3×10^{-3}
	Remainder of New Mexico	1.1×10^{-4}	4.2×10^{-4}	2.6×10^{-4}	1.1×10^{-3}
Relief Route	U.S. 84/285 to I-25	9.4×10^{-5}	3.6×10^{-4}	9.6×10^{-5}	3.8×10^{-4}
	Remainder of New Mexico	1.9×10^{-4}	7.0×10^{-4}	1.6×10^{-4}	6.6×10^{-4}

TABLE F.7.2–17.—Comparison of Major Chlorine and Propane Accident Risks for the Reduced Operations Alternative

ROUTE OPTION	ROUTE SEGMENT	CHLORINE		PROPANE	
		FATALITIES PER YEAR	INJURIES PER YEAR	FATALITIES PER YEAR	INJURIES PER YEAR
Route Through Santa Fe	U.S. 84/285 to I-25	2.7×10^{-4}	1.0×10^{-3}	1.4×10^{-4}	5.7×10^{-4}
	Remainder of New Mexico	4.8×10^{-5}	1.8×10^{-4}	1.1×10^{-4}	4.5×10^{-4}
Relief Route	U.S. 84/285 to I-25	3.9×10^{-5}	1.5×10^{-4}	4.1×10^{-5}	1.6×10^{-4}
	Remainder of New Mexico	7.8×10^{-5}	3.0×10^{-4}	7.1×10^{-5}	2.8×10^{-4}

TABLE F.7.2–18.—Comparison of Major Chlorine and Propane Accident Risks for the Greener Alternative

ROUTE OPTION	ROUTE SEGMENT	CHLORINE		PROPANE	
		FATALITIES PER YEAR	INJURIES PER YEAR	FATALITIES PER YEAR	INJURIES PER YEAR
Route Through Santa Fe	U.S. 84/285 to I-25	2.9×10^{-4}	1.1×10^{-3}	1.5×10^{-4}	6.0×10^{-4}
	Remainder of New Mexico	5.2×10^{-5}	1.9×10^{-4}	1.2×10^{-4}	4.8×10^{-4}
Relief Route	U.S. 84/285 to I-25	4.2×10^{-5}	1.6×10^{-4}	4.4×10^{-5}	1.7×10^{-4}
	Remainder of New Mexico	8.4×10^{-5}	3.2×10^{-4}	7.5×10^{-5}	3.0×10^{-4}

Chemicals were grouped in classes of materials such as flammable materials. RAMs were grouped in many more categories. First, general categories such as LLW, pits, samples, and irradiated targets were used. Then the general categories were divided into groups within which significant packaging differences could occur. For example, LLMW transported on site was aggregated into three groups: materials likely to be packaged in 55-gallon drums, materials likely to be transported in bulk, such as in covered dump trucks (soil and debris), and materials likely to be transported in 96-cubic foot boxes (contaminated lead and non-RCRA waste).

The incident-free risk is proportional to the TI value. The maximum legal value of 10 millirem was used unless there were data to the contrary. The conservatism in TI estimation is significant because most shipments are much less than the regulatory maximum.

Some small shipments are likely to have been missed. For example, on-site shipment of small quantities of special nuclear materials and chemicals are thought to have been overlooked in the data-gathering activity. These small shipments have no effect on the risk of bounding accidents and would contribute little to the incident-free and truck-related risk measures. The net effect is a significantly conservative estimate.

F.8.2 Amount per Shipment

In almost all cases, the number of packages per shipment was selected as less than full use of the truck capacity. In the case of contaminated laundry, for example, the current one truckload per week (sometimes with less than full capacity) is assumed to continue and the number of laundry bags is assumed to vary with alternative and with week-to-week and year-to-year variability in operations. The only exception to weekly shipments is that the increase for the expanded alternative was large enough to change the projection from a shipment every five working days to one every three working days.

Another example of less than full truck capacity is the case of LLW transported off-site. A waste volume equivalent to 65, 55-gallon drums, with an 80 percent volume utilization, was used for both LLMW and for LLW consisting of soil and debris. A tractor-trailer can hold 80 drums if weight limits are not exceeded. The volume per shipment, 389 cubic feet (10.9 cubic meters), also corresponds to that of a standard covered dump truck, but larger trucks could also be used. LLMW would likely go to several facilities, and full truck loads could be impractical. On the other hand, soil and debris would likely go to the same facility (in a given time frame), and full shipments would be a realistic expectation.

The objectives were to be conservative, but not overly so, in estimating amounts per shipment and to be consistent across alternatives.

F.8.3 Bounding Materials

It is impractical to compute the accident risk from every shipment. As described in subsection F.6.5.1, the approach is to select bounding materials for consequence analysis. Selection of the bounding materials was based on quantity, dispersibility, and health effects. Selection of bounding chemicals was straightforward: the toxic or flammable bulk gases are the obvious primary candidates. Highly dispersible actinides are the primary candidates for RAM; dispersion is enhanced by the physical form; e.g., powder, or by the presence of another dispersion-causing material; e.g., explosives. Highly irradiated materials are in a separate category, as are fissile materials.

Estimates of the number of bounding shipments are less straightforward because the frequency of shipments of similar materials should also be included. Obviously, shipments of materials that are slightly less dangerous than the bounding material should contribute to the frequency component of risk. The question is, how much less dangerous? As described in subsection F.6.5.1, the measure of danger chosen was the amount of material, and if the amount exceeded 10 percent of the bounding amount, then the shipment was counted in the frequency term. This is a conservative approach. The term “amount” for RAM was considered as the product of the weight in grams, the respirable airborne release fraction, and the health risk conversion factor of rem per gram.

F.8.4 Origin and Destination

A major simplification was the aggregation of the numerous origin and destination cities (other than the LANL site) to only a few cities. Doing

otherwise would have been impractical. The methodology introduced major conservatism in the route length of most shipments. The centroid city of each of the five regions was chosen so that the great majority of shipments were going to a city no farther away than the one chosen. First, the average HAZMAT shipping distance was determined for historical large shipments. Then a city in the northeast (toxic), southeast (explosives), and southwest (flammable) that was at that average shipping distance or farther from LANL was chosen. The conservatism introduced for HAZMAT shipments is likely much less than that for RAM shipments, because an average distance was computed for HAZMAT shipments, and a near-upper-bound distance was chosen on the basis of historical shipments for the RAM shipments.

The choice of SRS for the southeast centroid, when material has historically also been shipped to Florida, illustrates the logic underlying the choice of a near-upper-bound distance. Portions of Florida are farther from LANL than is SRS. However, approximately 94 percent of the historical ground shipments are to destinations no farther from LANL than is the SRS, and approximately 80 percent are to destinations significantly closer than the SRS. Therefore, choosing the upper bound distance (Florida) would be overly conservative because only about 6 percent of the shipments actually go to Florida. The logical choice is the near-upper-bound distance to the SRS.

Given the chosen city, no special conservatism was introduced when choosing other factors such as route, population density, or accident rate.

F.8.5 Package Release Probability

The package release probability is based on performance requirements for all packages of a given type (e.g., Type B). The package release probability used in this analysis would

correspond to the release probability of a package meeting the minimum performance requirements for its type. The conservatism would have to be quantified on a package-specific basis and such quantification would require substantial analyses.

F.8.6 Package Release Fractions and Respirable Airborne Release Fractions

The package release fraction is also based on performance for all packages of a given type, and the conservatism would have to be quantified for a specific package and contents.

The respirable airborne release fraction used for analysis for general commerce shipments corresponds to that for a loose, noncombustible powder that suddenly loses all barriers preventing its release (i.e., its packaging suddenly becomes equivalent to an open-top container). In fact, the actual powder is not loose, but compressed, and the packaging is unlikely to fail such that a line-of-sight opening develops. Rather, realistic package failures are more likely to produce an indirect path to the environment that would significantly reduce the fraction that could be made airborne and respirable in the environment. The respirable airborne release fraction used is estimated to be conservative by several orders of magnitude. Further definite quantitative refinement of the value used is not practical given the variety of packaging and release mechanisms considered.

F.8.7 Dispersion and Exposure

Standard dispersion computer programs (RADTRAN, ADROIT, DEGADIS, and ALOHA™) were used with the programs' default or recommended meteorological input. To establish population densities, most exposure calculations were based on census data; time-of-day variation could increase or decrease these values. The chlorine accident escape fraction and propane accident shielding fractions are intended to be average values, but few data are available to support the values used. The MEI doses are intended to be upper bounds for the default meteorological conditions.

F.8.8 Summary

Four risk measures (section F.3) are used in this appendix and each has a consequence and a frequency component. Although the uncertainties described previously do not apply uniformly to the eight risk components, a general statement can be made that each risk component is much more likely to be significantly conservative than to be slightly not conservative enough. This statement applies to all alternatives. A major ramification of the conservatism is that shipments in addition to those described in Tables F.5.3-1 and F.5.3.2-3 are enveloped by the present analysis.

REFERENCES

- Anonymous 1990 "Usher Transport Includes Customers, Others in Overall Safety Programs." *Modern Bulk Transporter*. Vol. 52, No. 12, pp. 36-43. June 1990.
- Anonymous 1994 "Manfredi Motor Transit Company Wins Back-To-Back Safety Awards." *Modern Bulk Transporter*. Vol. 56, No. 11, pp. 92-98. May 1994.
- BAA 1993 *Emergency Evacuation/Transportation Plan Update: Traffic Model Development and Evaluation of Early Closure Procedures*. Barton-Aschman Associates, Inc. Albuquerque, New Mexico. October 28, 1993.
- Barklay 1983 *Safety Analysis Report for Packaging (SARP) for the Mound I-kW Package, Revision 5*. C. D. Barklay. EG&G Mound Applied Technologies. MLM-MU-91-64-001. Miamisburg, Ohio. 1983.
- Clarke et al. 1976 *Severities of Transportation Accidents*. R. K. Clarke et al. Sandia National Laboratories. SLA-74-0001. Albuquerque, New Mexico. July 1976.
- Cruse 1992 *Test and Evaluation Document for DOT Specification 7A Type A Packaging*. J. M. Cruse. Westinghouse Hanford Company. WHC-EP-0558. Richland, Washington. June 1992.
- Dennis et al. 1978 *Severities of Transportation Accidents Involving Large Packages*. A. W. Dennis et al. Sandia National Laboratories. SAND-77-0001. Albuquerque, New Mexico. 1978.
- DOE 1990 *Waste Isolation Pilot Plant Disposal Phase Supplemental Environmental Impact Statement*. U.S. Department of Energy, Albuquerque Operations Office. DOE/EIS-0026-S1. Albuquerque, New Mexico. 1990.
- DOE 1994a *Framework for Assessing the Effects of Radioactive Materials Transportation in Defense Programs NEPA Documents, Revised Draft*. U.S. Department of Energy, Office of Defense Programs. Washington, D.C. June 1994.
- DOE 1994b *Airborne Release Fractions/Rates and Respirable Fractions for Nonreactor Nuclear Facilities*. U.S. Department of Energy. DOE Handbook 3010-94. Washington, D.C. October 1994.
- DOE 1995 *Dual Axis Radiographic Hydrodynamic Test Facility Final Environmental Impact Statement*. U.S. Department of Energy, Albuquerque Operations Office and Los Alamos Area Office. DOE/EIS-0228. Albuquerque, New Mexico. August 1995.

- DOE 1996a *The Environmental Impact Statement for the Nevada Test Site and Off-Site Locations in the State of Nevada*, Draft. Vol. I, Appendix I, "Transportation Study." U.S. Department of Energy, Nevada Operations Office. DOE/EIS-0243. Las Vegas, Nevada. January 1996.
- DOE 1996b *Final Programmatic Environmental Impact Statement for Stockpile Stewardship and Management*. U.S. Department of Energy. DOE/EIS-0236. Washington, D.C. September 1996.
- DOE 1996c *Final Environmental Impact Statement for the Continued Operation of the Pantex Plant and Associated Storage of Nuclear Weapon Components*. Appendix F, "Transportation Risk Analysis." U.S. Department of Energy. DOE/EIS-0225. Washington, D.C. November 1996.
- DOE 1998 *Final Environmental Impact Statement on Management of Certain Plutonium Residues and Scrub Alloy Stored at the Rocky Flats Environmental Technology Site*. U.S. Department of Energy. DOE/EIS-0277. August 1998.
- DOT 1992 *FAA Statistical Handbook of Aviation: Calendar Year 1992*. U.S. Department of Transportation, Federal Aviation Administration. FAA APO-94-5. Washington, D.C. 1992.
- DOT 1995a *Traffic Safety Facts 1994: A Compilation of Motor Vehicle Crash Data from the Fatal Accident Reporting System and the General Estimates System*. U.S. Department of Transportation, National Highway Traffic Safety Administration. DOT HS 808 292. Washington, D.C. August 1995.
- DOT 1995b *Hazardous Materials, Transportation Regulations: Compatibility with Regulations of the International Atomic Energy Agency, Final Rule*. 60 FR (188) 50297. 1995.
- Fenner 1995 Letter from H. Allen Fenner, Transportation Planning Division, New Mexico Highway and Transportation Department, to Joe Matlock. Santa Fe, New Mexico. November 13, 1995.
- Fenner 1996 Letter from H. Allen Fenner, Transportation Planning Division, New Mexico State Highway Department, to W. R. Rhyne. Santa Fe, New Mexico. January 17, 1996
- Glickman and Raj 1992 "A Comparison of Theoretical and Actual Consequences in Two Fatal Ammonia Accidents." T. A. Glickman and P. K. Raj. *Transportation of Dangerous Goods: Assessing the Risks*. F. Frank Saccomanno and Keith Cassidy, eds. Institute for Risk Research, University of Waterloo. Ontario, Canada. 1992.

- Green et al. 1996 *Hanford Site Truck Accident Rate, 1990–1995.* J. R. Green, B. D. Flanagan, and H. W. Harris. Westinghouse Hanford Company. WHC-SD-TP-RPT-021. Richland, Washington. March 1996.
- Harwood and Russell 1990 *Present Practices of Highway Transportation of Hazardous Materials.* D. W. Harwood and E. R. Russell. U.S. Department of Transportation. FHWA-RD-89-0134. Washington, D.C. 1990.
- Havens and Spicer 1985 *Development of an Atmospheric Dispersion Model for Heavier-than-Air Gas Mixtures.* J. A. Havens and T. O. Spicer. U.S. Coast Guard. CG-D-22-85. Washington, D.C. 1985.
- ICRP 1991 *Recommendations of the International Commission on Radiological Protection.* International Commission on Radiological Protection. ICRP Publication No. 60. Pergamon Press. New York. 1991.
- Johnson et al. 1993 *HIGHWAY 3.1 + An Enhanced Highway Routing Model: Program Description, Methodology, and Revised User's Manual.* P. E. Johnson, D. S. Joy, D. B. Clarke, and J. M. Jacobi. Oak Ridge National Laboratory. ORNL/TM-12124. Oak Ridge, Tennessee. March 1993.
- LLNL 1987 *Shipping Container Response to Severe Highway and Railway Accident Conditions.* L. E. Fischer et al. Lawrence Livermore National Laboratory. NUREG/CR-4829. Livermore, California. 1987.
- Neuhauser and Kanipe 1992 *RADTRAN 4, Volume III: User Guide.* K. S. Neuhauser and F. L. Kanipe. Sandia National Laboratories. SAND89-2370. Albuquerque, New Mexico. January 1992.
- Neuhauser and Kanipe 1995 *RADTRAN 4, Volume II: Technical Manual.* K. S. Neuhauser and F. L. Kanipe. Sandia National Laboratories. SAND89-2370. Albuquerque, New Mexico. 1995.
- NRC 1977 *Final Environmental Statement on the Transportation of Radioactive Materials by Air and Other Modes.* U.S. Nuclear Regulatory Commission. NUREG-0170. Washington, D.C. December 1977.
- NSC 1995 *ALOHA™ + Areal Locations of Hazardous Atmospheres, User's Manual.* National Safety Council. Itasca, Illinois. 1995.
- OTA 1988 *Gearing Up for Safety: Motor Carrier Safety in a Competitive Environment.* Congress of the United States of America, Office of Technology Assessment. OTA-SET-382. Washington, D.C. 1988.

- Phillips et al. 1994 *Determination of Influence Factors and Accident Rates for the Armored Tractor/Safe Secure Trailer*. J. S. Phillips, D. B. Clauss, and D. F. Blower. Sandia National Laboratories. SAND93-0111. Albuquerque, New Mexico. 1994.
- PNL 1980 *An Assessment of the Risk of Transporting Propane by Truck and Train*. C. A. Geffen et. al. Pacific Northwest Laboratory. PNL-3308. Richland, Washington. 1980.
- Rao et al. 1982 *Non-Radiological Impacts of Transporting Radioactive Material*. R. K. Rao, E. L. Wilmot, and R. E. Luna. Sandia National Laboratories. DE8-2012844. Albuquerque, New Mexico. February 1982.
- Rhyne 1985 *Probabilistic Analysis of Chemical Agent Release During Transport of M55 Rockets*. W. R. Rhyne. U.S. Department of the Army. M55-CD-4. Available from the Defense Technical Information Center. Washington, D.C. 1985.
- Rhyne 1994a *Hazardous Materials Transportation Risk Analysis: Quantitative Approaches for Truck and Train*. W. R. Rhyne. Van Nostrand Reinhold. New York, New York. 1994.
- Rhyne 1994b *Risk Management of the Transport of Irradiated Targets from LAMPF to TA-48*. W. R. Rhyne. H&R Technical Associates. SM-BUS-6-TQC-53.0. Oak Ridge, Tennessee. July 1994
- Rhyne 1997 Correspondence from W. R. Rhyne, H&R Technical Associates, to C. A. Cruz, U.S. Department of Energy. September 11, 1997.
- Saricks and Kvitek 1994 *Longitudinal Review of State-Level Accident Statistics for Carriers of Interstate Freight*. C. Saricks and T. Kvitek. Argonne National Laboratory. ANL/ESD/TM-68 (DE94-016625). Argonne, Illinois. March 1994.
- SSEB 1994 *Transuranic Waste Transportation Handbook*. Southern States Energy Board. Prepared under U.S. Department of Energy Cooperation Agreement DE-FC04-93AL82966. Norcross, Georgia. 1994.
- Vigil 1996 Letter from Alvaro Vigil, Transportation Planning Division, New Mexico State Highway and Transportation Department, to W. R. Rhyne, H&R Technical Associates. Santa Fe, New Mexico. January 25, 1996.
- Villa 1996 Presentation Viewgraph from SWEIS Transportation Workshop. Sandra A. Villa. Los Alamos National Laboratory. Los Alamos, New Mexico. September 24, 1996.

- Wangler 1995 *U.S. Department of Energy Certificate of Compliance for Radioactive Materials Packages.* M. E. Wangler. U.S. Department of Energy. Certificate No. 9932. Washington, D.C. December 1, 1995.
- Wangler 1996 *U.S. Department of Energy Certificate of Compliance for Radioactive Materials Packages.* M. E. Wangler. U.S. Department of Energy. Certificate No. 5320. Washington, D.C. March 25, 1996.
- WGA and DOE
1995 *WIPP Transportation Safety Program Implementation Guide.* Western Governors' Association Technical Advisory Group for WIPP Transport and the U.S. Department of Energy, Carlsbad Area Office. Carlsbad, New Mexico. November 1995.
- Wilson 1990 "Enterprise Transportation Wins Big with Daily Focus on Fleet Safety." C. E. Wilson. *Modern Bulk Transporter.* Vol. 52, No. 12, pp. 24-34. 1990.

APPENDIX G

ACCIDENT ANALYSIS

G.1 INTRODUCTION

The NEPA decision maker and the stakeholders need to know the consequences of the different SWEIS alternatives. Some but not all of the consequences are those of the possible accidents. Accidents are defined as unexpected or undesirable events that lead to the release of hazardous material within a facility or into the environment (DOE 1996a), exposing workers and/or the public to hazardous materials or radiation.

There are two benefits from this SWEIS accident analysis. First, the analysis conservatively characterizes the overall risk posed by the operation, creating a context for the decision maker and putting the site in perspective for the public. Second, it quantifies the increment in risk among the several alternatives, as an input into the decision.

G.1.1 Characterization of the Risk from Accidents

Characterization includes a consideration of the type of the accident (e.g., fire, explosion, spill, leak, depressurization, criticality, etc.), the initiator (e.g., human error, chemical reaction, earthquake, strong wind, flood, vehicle accident, mechanical failure, etc.) the material at risk (e.g., plutonium, tritium, toxic chemical, explosives, inflammable gas, etc.). Characterization also considers the type of consequences of the accident (e.g., immediate fatalities, prompt reversible and irreversible health effects, latent cancers—some of which lead to eventual death), and the magnitude of the consequences (e.g., to workers only, to hypothetical members of the public, to a few, some or many real individuals off site, etc.).

Finally, characterization considers the likelihood that an accident will occur.

Because LANL is a complex and diverse site, there are (as at any site) a wide range of accident scenarios that can be hypothesized, with a corresponding range of likelihoods and consequences, both realistic and imagined. For this SWEIS we analyze accidents that could result in the release of hazardous materials from particular facilities and operations. While such releases are not routinely expected, because controls are in place to prevent such releases or limit their consequences, there are many scenarios that could potentially end in such a release. The analyses in this SWEIS select the more probable scenarios.

To characterize the accident risk at LANL, this analysis has deliberately chosen a range of types of accidents and a range of consequences, including among these accidents for which the public has shown concern. This analysis does not attempt to identify every possible accident scenario, but instead selects accidents that characterize or dominate the risk to the public from site operations (referred to as risk-significant accidents). It thereby provides an objective context for the public to evaluate the risk posed by site operations and a context for the decision among alternatives.

Accident scenarios may be considered “risk-significant” when they pose risks that are significant in the context of the total risk posed by the site and when compared to other site accidents. The term “risk-significant” does not imply a threshold or particular magnitude of risk. If the risk posed by the site is small or very small, then a risk-significant accident at that site has a correspondingly small or very small risk.

By identifying the locations of appreciable quantities of hazardous material, the accidents associated with these materials can be assessed. By grouping these accidents according to their likelihood or frequency and the magnitude of their consequences, it is possible to select accidents for further characterization and qualitatively portray their relative risk. The accidents selected for this detailed analysis are those with bounding consequences as well as those that characterize the risk of operating LANL.

Such grouping or “binning” of accidents is illustrated in Figure G.1.1–1. Accidents assigned to bins within a row vary in terms of their consequences but not their frequencies. Accidents assigned to bins within a column vary in terms of their frequency but not their consequences. Accidents have an increasing level of risk going from left to right within a row or from bottom to top within a column. Accidents that are in the same bin have about the same risk. Thus, when accidents are considered within the context of this matrix, they can be compared qualitatively, and their relative risk ranking can be used for decision making.

There can be, however, a large number of different potential accidents or scenarios at a site such as LANL, especially of those in the high probability-low consequence bins (for example, minor industrial accidents). However, the risk changes exponentially as one goes from one column or row to another. Therefore, by selecting accidents with the highest consequences for a particular frequency row, the accidents that contribute the most to the overall risk to the public from site operations can be considered. Also, these accidents can be characterized by the type of material-at-risk, accident initiators, their scenario progression, and the type and magnitude of their consequences. In particular, the question can now be considered as to the degree by which the risk-significant accidents change across the alternatives. In other words, is there a decision

within this SWEIS that could and should be influenced by a change in risk? Not until the potential accidents change, from at least one frequency range or consequence range to another, or accidents are added or deleted as a result of changes in mission and operations, does the risk profile for the site change significantly.

Any particular facility or inventory can be affected by a wide variety of accidents that may have about the same frequency and about the same consequences. For instance, some of the gases in cylinders at a gas cylinder storage facility can be released by fire or by impact from a variety of initial causes. All of these accidents might have similar frequencies and consequences, and so can be represented by a “representative accident.” (In the analysis, the frequency of that representative accident might be increased to account for other initiators that lead to the same release.) Conversely, there may be at that storage facility, at times, a larger inventory of a particularly toxic gas whose probability of release is low but that would have larger consequences than releases of the other gases. This postulated accident would be a “bounding accident” whose consequences would not be exceeded with any reasonable possibility or probability. For purposes of a SWEIS, the bounding accidents are intended to provide an envelope that captures variations in routine operations and inventories whose details cannot be predicted.

These representative and bounding accidents characterize the many accidents that could be postulated for that material or facility. There would be no benefit gained in a SWEIS from analyzing each of the many accidents so characterized.

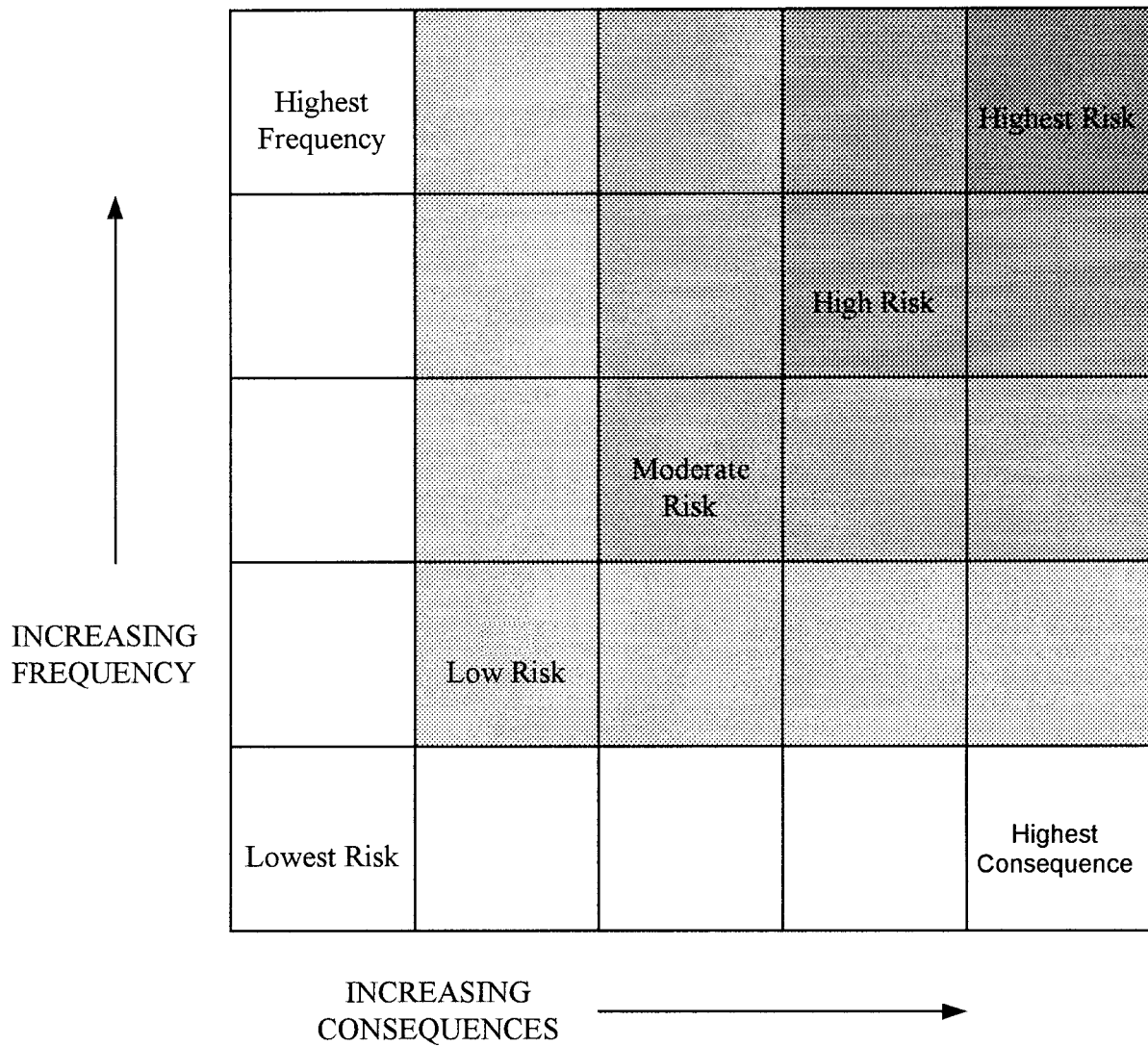

FIGURE G.1.1-1.—Facility Accident Risk Matrix.

G.1.2 The Meaning of Risk and Frequency as Used in this SWEIS

The word “risk” is defined in the dictionary as the probability that a specific loss or injury will occur. However, if the injury would be small, then most people would agree that the risk posed by the venture is small also. Therefore, DOE couples the consequence of an event with the probability that it will occur, and calls this combination the “risk.” Note that a high-consequence event would not necessarily have significant risk (in the context of NEPA analysis) if its probability is very low.

For many events, the risk can be expressed mathematically as the product of the consequence and its probability. In illustration, if the expected public consequence of an accident at a particular facility is one cancer per accident, and if the accident has a probability of occurring once during a period of 1,000 years, then the continuing risk presented by that accident is $1 \times 1/1000$ or 0.001 excess latent cancer per year. This product of consequence and probability is called “societal risk” in this SWEIS. It permits the ready comparison of accidents and alternatives without the burden of the details. The details are presented in this appendix.

The probability of the accident is typically expressed as its estimated frequency; that is, an accident with a frequency of 1×10^{-3} per year has a probability of occurring once in 1,000 years and twice in 2,000 years. This is another way of saying that the probability of the accident occurring in any particular year is 1 in 1,000. In the case of natural phenomena, this is also expressed as a “return period” of 1,000 years. This does NOT mean that once the phenomenon occurs, it will be another 999 years before it occurs (returns) again, because the probability is with regard to its occurring in any selected 12-month period¹.

G.1.3 Determining the Increment in Risk Among Alternatives

Although it is possible to characterize or represent the risk posed by the operation, there are too many possibilities and uncertainties to quantify the total absolute risk. Any attempt to adjust the expected frequency and calculated consequences of risk-dominant accidents so that their sum would equal the total risk of all accidents would be self-deceptive, as all these innumerable possibilities are not independent of one another nor accurately quantifiable.

In this SWEIS analysis, it was found that the nature of the accidents did not change among the alternatives; but the frequency and consequence of some of the accidents did change somewhat. Recalling that risk is the product of the consequence and its probability, it is therefore possible to provide the decision maker with estimates of the difference in risk among the alternatives. These differences are discussed later (in summary) in Table G.5–1.

To communicate the types of risk present at LANL, the detailed methodology and results are described below. The methodology considers accidents that are reasonably foreseeable. Although “reasonably foreseeable” does not have a precise definition, the accident analysis is guided by the primary purpose of making reasonable choices among alternatives. “Reasonably foreseeable” includes impacts that may have very large or catastrophic

1. This statement is correct from a statistical standpoint but must be qualified for certain events. In the case of natural phenomena, every occurrence and every nonoccurrence adds to the database from which the probabilities are estimated, so the probabilities do change. In the case of earthquakes, an occurrence may relieve stresses and reduce the probability of another quake for some time; whereas, in the case of heavy flooding, several occurrences in a few years suggest that floods may be more likely than the original data indicated. The important point is that the frequency and/or return period are estimated measures of the probability of an occurrence, not predictions of when it will occur.

consequences, even if their frequency of occurrence is low, provided that the impact analysis is supported by credible scientific evidence, is not based on pure conjecture, and is within the rule of reason.

If an accident is not reasonably foreseeable (incredible), DOE does not consider that it contributes substantially to the risk of operating LANL (DOE 1993a). If, on the other hand, a hazardous material has a reasonable chance of being involved in an accident, then the consequences and the likelihood of the accident are considered.

Specific accidents that contribute substantially to, or envelop the risk, are considered risk-dominant accidents or bounding accidents. They are not exceeded by other accidents analyzed or believed to be possible that involve that inventory. For instance, there may be a number of accidents that could disperse plutonium, with different initiators or different mitigation; but they are represented by the risk-dominant accident involving plutonium dispersal. This accident also may bound the consequences for other facilities that may have more sensitive site characteristics, such as larger populations, but have lesser inventories than those addressed by the analyses.

There is no intent or expectation that the sum of the consequences of these accident scenarios will add quantitatively to the total risk of the LANL site. However, from the results of this methodology, the decision maker is informed of the nature and magnitude of the risk posed by operating LANL facilities.

G.1.4 The Methodology for Selection of Accidents for Analysis

The analysis began with the establishment of the baseline risk from current operations, plus planned activities, that together constitute the No Action Alternative. The baseline was

established by a process of safety documentation review, interviews with facility management, physical inspections (walkdowns) of facilities, and discussions with facility management. Changes in the baseline risk were estimated for the Expanded Operations Alternative, the Reduced Operations Alternative, and the Greener Alternative to ascertain the human health impacts of the alternatives².

Assessing the human health consequences of accidents for the alternatives is a four-step process. The first step was to identify a broad spectrum of potential accident scenarios. These scenarios were obtained from available site-specific safety and environmental documents, programmatic documents, discussions with facility management, and physical inspections (walkdowns) of the facilities.

The second step in the process used screening techniques to identify the specific scenarios that contribute significantly to risk (i.e., the scenarios that contribute an appreciable fraction of the total risk). Due to the large number of potential accident scenarios that could impact human health, it is impractical to evaluate them all in detail. This is a common problem encountered in risk assessments, and the standard approach (which was adopted here) is to apply rough bounding calculations during the screening steps.

² Recall, from chapter 3, that the No Action Alternative is the continuation of current operations without change in mission or the nature of operations. The Reduced Operations Alternative would be a reduction in activities to those necessary to maintain the capability in the near term. Under the Expanded Operations Alternative, operations could increase to the highest reasonably foreseeable levels over the next 10 years that can be supported by the existing infrastructure (including upgrades and construction). The Greener Alternative uses existing capabilities, but also places an emphasis on basic science, waste minimization, dismantlement of weapons, nonproliferation, and other nonweapons areas of importance, resulting in increased activities and operations in those areas of interest.

The calculations are performed to progressively greater degrees of detail until it becomes clear that the accident is either, not risk-significant, or requires a detailed analysis in order to determine the frequency and consequences of the accident (i.e., its risk).

Rigorous evaluations (the third step in the process) were only performed for the potentially risk-dominant scenarios identified in step two, that is, those which had a frequency of 10^{-6} or more and led to off-site consequences beyond insignificant.

During the third step in the process, it was determined that a number of scenarios that had appeared to be risk-significant during the earlier screening steps were in fact insignificant contributors to risk. This situation arises due to the conservative approaches to frequency binning used in safety analysis reports (SARs), as described in DOE Standard 3009-94 (DOE 1994a). DOE facilities for which SARs are prepared are subjected to the most detailed assessments; less hazardous facilities are the subject of less detailed evaluations, in accordance with the graded approach to safety analysis. For facilities with SARs, potential accidents are assigned to one of the frequency bins identified in Table G.1.4-1 (DOE 1994a). In the DOE Standard 3009-94 approach, accident frequency binning is essentially a qualitative process rather than the product of a rigorous quantitative analysis. Accordingly, frequency bin assignments are made conservatively such that if a detailed quantification were performed, the calculated frequency would not place the accident in a higher bin and would in fact be more likely to result in placement in a lower frequency bin. Sometimes, simple methods are used for frequency binning, such as assigning a conditional probability of 1 for dependent events, a conditional probability of 0.1 to human errors, and a conditional probability of 0.01 to genuinely independent events.

At the end of the detailed accident analyses, it was found that a number of accidents had been assigned to higher frequency bins than warranted. Specifically, this was the case for RAD-02, RAD-04, RAD-06, RAD-10, RAD-11, and RAD-14, all of which were found to have mean frequencies of less than 10^{-6} per year. (The sequence of events described for RAD-10 was found to be credible for worker consequences because release out of the building is not necessary to result in worker exposures.)

The fourth step in assessing the human health impact of accidents for the alternatives was to carefully evaluate the effect of the alternatives on the accident scenarios. The important considerations involved in this evaluation were whether the alternative would result in the elimination of some accidents and the addition of others, whether the alternative would result in an increase or decrease in the frequency of some accidents, and whether the alternative would result in an increase or decrease in the amount of hazardous materials released. The results of the analysis indicate that, while a number of accidents are potentially affected by the alternatives, few of them pose significant risk to the public.

In the context of LANL, it is important to recognize that, as a result of several factors (the nature of the activities performed, the design features of the facilities at which the activities are performed, the conditions under which the activities are performed, and the location of the facility vis-a-vis the public), accidents are more likely to impact facility workers than they are to impact the public. This is true even though at LANL the public has access to many areas of laboratory via roadway (public access to roads through LANL can be controlled by DOE in the event of an accident). Even for facility workers, the consequences in many cases would be dependent on the use by facility workers of personal protective equipment (PPE) and on the

effectiveness of emergency response and mitigation actions taken to limit consequences (e.g., the timeliness of evacuation from the facility).

G.1.5 Comparison of Other Accident Analysis to the SWEIS

The DOE, through its safety and environmental programs, conducts a variety of hazard and safety analyses for various purposes. Because all of the safety and hazard analyses are performed for different purposes, varying levels of conservatism, and therefore, different assumptions are made about physical phenomena and preventive and mitigative controls. In the analysis, if the applicable safety objectives or standard criteria can be met with a very conservative set of assumptions, then detailed analysis is not considered necessary. Further analysis is generally done to more accurately predict an outcome when greater realism is sought, or when very conservative assumptions lead to results that exceed safety objectives or criteria. Detailed analysis requires sophisticated calculations, and therefore, greater expenditure of resources. If a very conservative estimate of consequences demonstrates that the impacts to the public, environment, and worker are acceptable within regulation or guidelines, then it is unnecessary to incur higher costs to more accurately predict the outcome. This fact may be acknowledged in the safety or hazard analysis, but no further quantification of actual doses is made. This graded approach to accident analysis is an explicit part of the DOE safety policy.

In order to understand the results of the accident analysis as presented in this SWEIS compared to other safety analyses and environmental assessments, a brief discussion of hazard assessments is given in the following sections. This discussion assumes a release of radiological material.

G.1.5.1 DOE Hazard Assessments

The hazard assessment is a comprehensive evaluation of hazards associated with a particular activity or operation. The hazard analysis provides a clear definition of the activity and the facilities in which the activities will be conducted. The hazard analysis identifies potential accident scenarios. From this preliminary analysis, preventative and mitigative equipment (i.e., systems, structures and components) are identified, and controls on features are established. Not every scenario is analyzed but several (often hundreds) are postulated, and those with the greatest potential for off-site consequences are usually selected as “bounding.”

The hazard assessment starts with a very conservative analysis of an accident. Although activities are not conducted without the use of controls, a hypothetical baseline is established that considers only the physics of the accident, such as atmospheric dispersion, not the controls that would either prevent or mitigate the consequences. This accident may be referred to as a “parking lot scenario” or a “what-if” scenario. It is a hypothetical scenario used to gauge the reduction in consequences or frequency provided by control mechanisms.

Given this estimate of a material release and considerations of atmospheric transport, the consequences are evaluated for a member of the public standing at the site boundary. This hypothetical individual receives a dose from their exposure to a passing cloud of hazardous material. The individual is assumed to remain at this location for the entire passage of the cloud or plume. These assumptions are designed to give a maximum exposure from the hazardous material release. If the dose to this individual is less than the DOE safety evaluation guideline, then the equipment associated with this activity does not need to be designated as safety class equipment. This implies that quantifying the reduction in consequences due to additional

safety controls is not necessary. However, hazard assessments will often give an expected dose based on taking credit for barriers such as building high efficiency particulate air (HEPA) filters, building confinement, etc. This equipment will then have necessary controls placed on it in order to assure its operability in the event of the analyzed bounding accident.

G.1.5.2 Accident Analysis for this SWEIS

As described above, the hazard assessment may provide a more conservative value for the frequency of an event. This result usually reflects an estimate of the frequency of initiating events and not the overall frequency of public impacts. The final results for the SWEIS, however, included the consideration of multiple barriers; generally it considered administrative barriers, process design barriers, and facility design barriers, as appropriate. Although, the consequences of a what-if scenario were considered, they were placed in the context of their frequency of occurrence.

As a rule of thumb, most process events become “incredible.” If an initiating event is considered anticipated, or has a frequency on the order of 10^{-1} , and there are three independent controls (each with an estimated probability of failure of 10^{-3}), then the overall frequency of the event becomes incredible at 10^{-10} . Therefore, once the SWEIS took credit for these barriers, the frequency of many of the accidents became less than 10^{-6} .

Several scenarios, even though they are incredible, are provided in this appendix to illustrate the defense-in-depth policy of the DOE. These accidents are retained in this appendix to preserve the information they contain, in illustration of the range of the analyses, and in demonstration of the conservative nature of the screening. Incredible accidents are not relevant to the decision and so

are segregated from credible accidents in volume I of the SWEIS.

The lower frequencies are difficult to comprehend. To provide a perspective for these frequencies, some examples of natural phenomena events at LANL are provided in Table G.1.5.2-1. Estimates of large meteor impact frequencies are included in order to be able to attain the lowest frequency range.

Although specific scenarios were analyzed, the results of the detailed evaluation represent a risk profile for LANL, given the types of operations described under each alternative. As long as specific process configurations support the same type of operations as considered in these alternatives and are implemented consistent with the DOE safety program, then the risks would be represented by the same set of accidents as presented for each alternative in this SWEIS.

G.1.6 Conservatism in the Analyses

At all steps, when faced with uncertainties, the analysts selected the most probable or conservative value for accident likelihoods and the quantity of hazardous materials released. Accepted models and conservative atmospheric dispersion parameters were used in the modeling. Exposure conditions (e.g., location, material released, time in the plume) were used that would maximize exposure of the total population and of individuals. The maximum risk factor for excess latent cancer fatalities (LCFs) was used to calculate health effects; whereas, the true risk factor may be considerably less, as described in appendix D, section D.1. The resulting estimates of risks are considered to be quite conservative. Incredible accidents are not relevant to the decision and so are segregated from credible accidents in volume I of the SWEIS.

TABLE G.1.5.2-1.—Frequency of Some Natural Phenomena Events at LANL

DESCRIPTIVE WORDS	RANGE OF ANNUAL FREQUENCY OF OCCURRENCE	PHENOMENON AND ITS FREQUENCY
Anticipated	10^{-2} to 10^{-1}	^a Wind of 80 mph, 10^{-2} . 11.2 inches precipitation in one month and 64.8 inches snowfall in one month ^b , 1.2×10^{-2} .
Unlikely	10^{-4} to 10^{-2}	^a Wind of 95 mph, 10^{-3} . ^c Snowfall adding 35.0 inches in depth in 24 hours, 5×10^{-3} , rainfall of 2.7 inches in 24 hours, 5×10^{-3} . ^d Meteor causing destructive tidal wave somewhere on earth, 2×10^{-4} . ^e Magnitude 6.5 earthquake causing walls to fall, houses to shift from unsecured foundation, and cracks to open in wet ground, 10^{-4} .
Extremely Unlikely	10^{-6} to 10^{-4}	^a Straight line wind of 120 mph, 10^{-5} . Tornado with wind of 70 mph, 10^{-5} .
Incredible	$< 10^{-6}$	^a Tornado with wind 150 mph or greater, 2.5×10^{-7} . ^d Meteor at least three miles in diameter striking somewhere on the earth, 10^{-7} .

^a Reference for LANL wind and tornado frequency (LLNL 1985). mph = miles per hour

^b Estimated from the record annual precipitation at LANL during November 1910 to December 1997 (Source: <http://weather.lanl.gov>)

^c Reference for 24-hour precipitations: LANL 1990a

^d Estimates of worldwide meteor probability: PC 1998

^e LANL earthquake data from Tables 4.2.2.2-2 and 4.2.2.2-3 in chapter 4.

G.2 HAZARDOUS MATERIALS IMPACTS ON HUMAN HEALTH

This section addresses the human health impacts resulting from exposure to hazardous materials. The sources of radiation pertinent to this SWEIS are examined in the first subsection. This discussion is followed by a discussion of health impacts resulting from exposure to hazardous chemicals. Finally, the computer models used to evaluate the consequences from both chemical and radiological accidents are discussed to provide an understanding of the applications and limitations of the models.

G.2.1 Sources of Radiation

The sources of radiation pertinent to the accident analysis in this SWEIS are facility specific. These sources include industrial sources used to generate x-rays and other types

of electromagnetic radiation for nondestructive examination of components and assemblies. Exposure to these sources of radiation only poses a potential risk to workers and to others with authorized access to the facilities where these sources are in use. Facility-specific sources of radiation also include materials released into the environment as a result of an accident. In most cases, these materials are tritium and various mixtures of uranium and plutonium isotopes. In some cases where experiments involve pulse reactors or critical assemblies, or where criticality occurs inadvertently, fission products also can be released. Each accident scenario that involves radioactive materials includes a discussion of the isotopes and quantities considered. (The nature of radiation, and its effects on human health are discussed in section D.1 of appendix D, Human Health.)

G.2.2 Human Health Effects of Exposure to Hazardous Chemicals

Human health effects resulting from exposure to hazardous chemicals vary according to the specific chemical of interest and the exposure route and concentration. The most immediate risks to human health from exposure to chemicals in the environment arise from airborne releases of toxic gases, and it is this route of exposure upon which the accident analysis for the SWEIS is focused. (The effects of toxic chemicals are discussed in section D.1 of appendix D, Human Health.) In this analysis, exposures to toxic chemicals are compared to Emergency Response Planning Guidelines (ERPGs). ERPGs are community exposure guidelines derived by groups of experts in industrial hygiene, toxicology, and medicine. ERPGs are then published by the American Industrial Hygiene Association (AIHA) after review and approval by their ERPG Committee. ERPGs are defined as follows (AIHA 1991):

- ERPG-1 is the maximum airborne concentration below which it is believed that nearly all individuals could be exposed for up to one hour without experiencing other than mild, transient adverse health effects or perceiving a clearly defined objectionable odor.
- ERPG-2 is the maximum airborne concentration below which it is believed that nearly all individuals could be exposed for up to one hour without experiencing or developing irreversible or other serious health effects or symptoms that could impair their abilities to take protective action.
- ERPG-3 is the maximum airborne concentration below which it is believed that nearly all individuals could be exposed for up to one hour without experiencing or developing life-threatening health effects.

Human responses to chemical exposure do not occur at precise exposure levels, but rather, extend over a wide range of concentrations. The values derived for ERPGs do not protect everyone, but are applicable to most individuals in the general population. Furthermore, the ERPG values are planning guidelines, not exposure guidelines. They do not contain the safety factors normally associated with exposure guidelines (AIHA 1991).

In developing an ERPG, emphasis is given to the use of acute or short-term exposure data. Human experience data are emphasized; but usually only animal exposure data are available. When it is believed that adverse reproductive, developmental, or carcinogenic effects might be caused by a single acute exposure, the data are considered in the ERPG derivation.

Unless one is provided information to the contrary by toxicologists, it is necessary to regard ERPGs as ceiling concentrations (i.e., the highest concentration acceptable for the time period). As such, the ERPG would be treated as an exposure that should not be exceeded within 1 hour. Any extrapolation from the ERPG is not to be made without significant considerations; specifically, to make such an adjustment, the ERPG documentation for each chemical must be reviewed fully by toxicologists. The effects of exposure times longer than 1 hour may not be limited to those associated with the ERPG.

In addition to ERPGs, this analysis incorporated the temporary emergency exposure limits (TEELs) developed by the DOE Emergency Management Advisory Committee, Subcommittee of Consequence Analysis and Protective Actions (SCAPA). Published ERPG values were available for only 69 chemicals. TEEL values are interim, temporary, or ERPG-equivalent exposure limits provided for an additional 297 chemicals. In the absence of ERPG or TEEL values, the hierarchy developed by SCAPA and published in the AIHA Journal was utilized (Craig et al. 1995).

ERPG-1 defines a level that does not pose a health risk to the community but that may be noticeable due to slight odor or mild irritation. Above ERPG-2, for some members of the community there may be significant adverse health effects or symptoms that could impair an individual's ability to take protective actions. These symptoms might include severe eye or respiratory irritation or muscular weakness. Above ERPG-3 there may be life-threatening effects and, at sufficiently high concentrations and exposure times that vary with the chemical, there could be death. The length of an individual's exposure to high concentrations will depend upon that individual's situation and response (that is, by his/her recognition of the threat and its location, attaining shelter, and escaping). Later in this analysis, consequences are presented as the number of people exposed to concentration greater than the ERPG-2 and ERPG-3 guidelines; but there are too many uncertainties to speculate as to the specific effects that would occur to those people.

G.2.3 Chemical Accidents—ALOHA™ Code

The Areal Locations of Hazardous Atmospheres (ALOHA™) code developed by EPA, the National Oceanographic and Atmospheric Administration (NOAA), and the National Safety Council (NSC), was used for the analysis of chemical releases. It is listed by DOE (DOE 1994c) and EPA (EPA 1996) as an acceptable code for air dispersion modeling.

The ALOHA™ code is designed to be used for emergency responders in the case of chemical accidents. The code predicts the rate at which chemical vapors may escape to the atmosphere from broken gas pipes, leaking tanks, and evaporating puddles and predicts how the resulting hazardous gas cloud disperses horizontally and vertically into the atmosphere following release (NSC 1995).

Especially near the source of a release, short-term gas concentrations depart markedly from average values in response to random turbulent eddies and are unpredictable. As the cloud moves downwind, concentrations within the cloud become more similar to ALOHA™ calculations. ALOHA™ shows concentrations that represent averages for time periods of several minutes and predicts that average concentrations will be highest near the release point and along the center line of the release cloud (this is typical Gaussian plume modeling). The concentration is modeled as dropping off smoothly and gradually in the downwind and crosswind directions.

ALOHA™ models neutrally buoyant gases with a Gaussian plume model. Airborne particulates are assumed to be passive; that is, they behave as nonbuoyant gases. Heavy gases are modeled using a variation of the DEGADIS heavy gas model. Some simplifications were implemented into ALOHA-DEGADIS to speed computational procedures and reduce the requirement for input data that would be difficult to obtain during an accidental release. These simplifications include the assumptions that: (1) all heavy gas releases originate close to ground level; (2) mathematical approximations are faster but less accurate than those in DEGADIS; and (3) modeling sources for which the release rate changes over time as a series of short, steady releases rather than a number of individual point source puffs. The authors worked closely to ensure a faithful representation of DEGADIS model dynamics, and the resulting ALOHA-DEGADIS model was checked to ensure that only minor differences existed in results.

Although ALOHA™ models the dispersion of heavy gases, the model assumes that the terrain is flat. Thus, if canyons are located between the release point and a potential receptor, ALOHA™ models the scenario as though the canyon were not present. This is a conservative

approach because receptors are offered no protection from heavy gases by intervening canyons. Under the most stable atmospheric conditions (most commonly found late at night or very early in the morning), there is little wind, reduced turbulence, and less mixing of the release with the surrounding air. High gas concentrations can build up in small valleys or depressions and remain for long periods of time. ALOHA™ does not account for buildup of gas concentrations in low-lying areas. The properties of a heavy gas are discussed in section G.5.5.

ALOHA™ allows the user to enter only a single wind speed and wind direction, and assumes that these remain constant throughout the release and travel. In reality, air flow changes speed and direction when confronted with changes in terrain such as slopes, valleys, and hills. ALOHA™ ignores these effects. Because wind is likely to shift direction and change speed over both distance and time, ALOHA™ will not make predictions for more than 1 hour after a release begins, or for distances more than 6.2 miles (10 kilometers) from the release point. In general, wind direction is least predictable when the wind speed is low and at the lowest wind speed modeled in the code (1 meter per second), ALOHA™ presents the footprint as a circle. ALOHA™ does not calculate particulate settling and deposition. The ALOHA™ code presumes the ground beneath a leak or spill to be flat, so that the liquid expands evenly in all directions.

Combustion products rise rapidly while moving downwind, until they cool to the temperature of the surrounding air. ALOHA™ does not account for this rise. ALOHA™ models the release and dispersion of pure chemicals only, and the properties of chemicals in its chemical library are valid only for pure chemicals. ALOHA™ also does not account for chemical reactions of any kind. (This limitation can be avoided by modeling the resulting chemicals, if known. In the case of the seismic collapse of TA-3-66, the SWEIS has modeled the

hydrogen cyanide that evolved from mixing metal cyanide solution and nitric acid.)

The limitations of ALOHA™ do not detract from its use in this SWEIS for screening chemical accidents and bounding their daytime consequences. During the preparation of this SWEIS, as upgrades to ALOHA™ code became available they were used. Trial calculations showed that the upgrades provided the same results as previous versions for the same inputs.

G.2.4 Radiological Accidents—MACCS 2 Code

The MACCS 2 computer code models the consequences of an accident that releases a plume of radioactive materials to the atmosphere. Should such an accident occur, the radioactive aerosols and/or gases in the plume would be transported by the prevailing wind while dispersing horizontally and vertically in the atmosphere. MACCS 2 uses a straight-line Gaussian plume model and the source term data input by the user to model the atmospheric dispersion and deposition of radionuclides released from facilities. Plume rise, dry deposition, and precipitation scavenging (below cloud washout) of aerosols, and resuspension of particulate matter that has deposited from the plume is explicitly modeled. The chronic exposure model calculates the resulting doses for all inhabitants living in the area. In the intermediate and long-term phases, the inhalation shielding factor for normal activity is used in the dose calculations. Decay of radionuclides to daughter products is accounted for.

The MACCS 2 calculations also estimate the range and probability of health effects caused by radiation exposures that are not avoided by protective actions. In these EIS calculations, no credit was taken for protective measures that might and would be used to decrease exposures. (MACCS 2 permits the modeling of various protective measures, such as evacuation,

sheltering, and relocation. A variety of protective measures can be taken in the long-term phase in order to reduce doses to acceptable levels: decontamination, interdiction, and condemnation of property.)

MACCS 2 divides the accident into three time phases: the emergency phase, the intermediate phase, and the long-term phase. The emergency phase begins immediately after the accident and could last up to 7 days following the accident. In this period, the exposure of the population to both radioactive clouds and contaminated ground is modeled. In the intermediate phase, the radioactive clouds are gone, and decisions are made regarding the type of protective actions that need to be taken; the only exposure pathways are those resulting from ground contamination. The long-term phase represents all time subsequent to the intermediate phase, and again, the only exposure pathways considered are those resulting from the contaminated ground.

In accidents there is an initial release, and there may be a continuing release thereafter. A single MACCS 2 calculation can handle four separate releases. To account for reduction of the source as it was depleted by the continuing suspension, the continuing release was treated as three consecutive continuing releases of 8 hours each. For those accidents that have both an initial and a continuing release, the releases were stopped no later than 24 hours after the initial release.

The region surrounding the site is divided into a polar coordinate grid centered on the facility from which the release originates. The angular divisions used to define the spatial grid correspond to the 16 directions of the compass. The user specifies the number of radial divisions as well as their endpoint distances. Up to 35 of these divisions may be defined, extending out to a maximum distance of 6,213 miles (10,000 kilometers).

The emergency phase calculations use dose-response models for early fatality and early

injury, and are performed on a finer grid than the calculations of the intermediate and long-term phases. For this phase, the 16 compass sectors are divided into 3, 5, or 7 user-specified subdivisions in the calculations.

Each radiological release site was assigned to the closest one of the four weather stations (located in TA-6, TA-49, TA-53, and TA-54). The 1995 meteorological data were used for these calculations. Sensitivity calculations using data from 1991 to 1995 have been performed for one accident scenario to investigate the possible impact on consequences of using weather data from a particular year. In the near field (out to 1,312 feet [400 meters]), an approximate maximum 30 percent variation occurred in the calculated doses, depending upon which year is used. The results indicated that 1995 yields the largest consequence results of this 5-year period for the scenario modeled (Steele et al. 1997).

Consequence results were calculated for both ground level and elevated releases, according to the facility and the scenario. Downwind concentrations of radionuclides up to a distance of 50 miles (80 kilometers) were calculated for each of the 16 compass directions around the facility. Radiation doses to the on-site and off-site population were calculated by the dosimetry models within MACCS 2³, using the concentrations. Exposure pathways were: direct radiation from the passing plume, direct radiation from radioactive material deposited on the ground and skin, inhalation while within the plume, and inhalation of resuspended ground contamination. Subsequent ingestion, which normally represents only a small fraction of total exposure and can be controlled, was not considered.

3. MACCS dosimetry models use risk factors that vary by nuclide, and result in approximately, but not exactly, an effective risk factor of 5×10^{-4} excess LCFs per person-rem of exposure. This is discussed in the primer on the effects of radiation in section D.1 of appendix D, Human Health.

Because population is not evenly distributed around the source, the consequences of an accident vary with wind direction. The probability of the consequence thus depends on the probability of that wind direction. Therefore, the results of the calculations are presented as the average of the consequences for all 16 directions weighted by the probability of the wind being toward that direction. Note that the calculations used both daytime and nighttime winds; whereas, the population distribution used was the daytime population described in section G.3.2. Because the daytime population is larger than the nighttime population, this overestimates the mean consequences.

Having the results from the multiple model runs, it was possible to calculate the mean dose to hypothetical individuals at points of closest public access; at points on the site boundary (referred to as doses to maximally exposed individuals [MEIs]); and mean doses at public population centers, such as towns, pueblos, and schools.

Note that these calculations capture all meteorological conditions, including the most adverse conditions, each weighted by its frequency of occurrence in the entire year. An alternative approach, use of the dispersion condition for which dispersion is greater than 95 percent the time (referred to as 95th percentile meteorology) is often used for screening. It maximizes the concentrations downwind, but does not consider the population distribution. Therefore, it does not provide as much useful information.

Note that uncertainties as to the models' abilities to predict concentrations and exposures, and uncertainties in the range of meteorological conditions, apply equally to all the alternatives.

G.3 ACCIDENT SCENARIO SCREENING

LANL is one of the largest multiprogram research laboratories in the world, and a number of factors combined to make the selection of accident scenarios for the SWEIS a challenging task. These factors included:

- DOE NEPA guidance that mandates consideration of accidents within the design basis, as well as those beyond the design basis, to identify a spectrum of potential accident scenarios that could occur during the activities encompassed by the proposed action and analyzed alternatives.
- The diversity of activities performed at LANL, including: pit production; high explosives research, development, production, and testing; special nuclear material (SNM) processing, research and development, and storage; hydrodynamic testing and dynamic experimentation; accelerator operations, research, and development; fusion power research and development; operation critical assemblies and fast burst reactors; and radioactive, chemical, and mixed waste processing, characterization, disposal, and storage.
- A wide range of accident initiators (including process hazards, man-made hazards, and natural phenomena hazards) and the resulting human, system, and structural responses to those initiators.
- A large number of accident scenarios identified in underlying programmatic and LANL-specific NEPA documents (e.g., the Stockpile Stewardship and Management PEIS, and the Dual Axis Radiographic Hydrodynamic Test [DARHT] Facility EIS).
- The availability and vintage of a variety of hazard assessment and safety analysis documentation, performed to evolving DOE guidance.

- The diversity of material that could potentially be released in an accident (referred to as “material-at-risk” or MAR), including: tritium, plutonium, various enrichments of uranium, toxic chemicals such as chlorine, bulk acid storage, high explosives, and a wide variety of other chemicals and radioactive materials.
- The presence of some relatively complex facilities such as the Plutonium Facility (TA-55-4), the Chemistry and Metallurgy Research (CMR) Building (TA-3-29), the Tritium System Test Assembly (TSTA) Facility (TA-21-155), the Tritium Science and Fabrication Facility (TSFF, TA-21-209), the Weapons Engineering Tritium Facility (WETF, TA-16-205), and the critical assembly and fast burst reactor facilities at the Pajarito site (TA-18), for which hazard and safety analyses have identified dozens to hundreds of credible accident scenarios for each of these facilities.

The large number of facilities and processes at LANL, combined with the diversity of MAR and the variety of accident initiators, produce credible accident scenarios numbering at least in the many thousands. Analyzing each of these scenarios in detail is neither required under NEPA nor practical. Ideally, a comprehensive risk assessment would express the total human health risk as the sum of all potential accident scenarios. It is neither practical (due to cost) or necessary (from a NEPA compliance standpoint) to rigorously quantify all of these to produce a summation of the total risk. The purpose of screening is to identify for detailed analysis a suite of accidents that constitute a large fraction of the total risk.

Accident analyses, for a NEPA document, involve considerably less detail than a formal probabilistic risk assessment (PRA), but make use of PRA techniques and insights (such as event trees, failure rate data, and initiating event

occurrence data) to identify risk-significant accident scenarios.

G.3.1 Accident Initiator Screening

It was recognized, based on review of available safety documentation for several important facilities, that there would be a very large number of credible accident scenarios for LANL facilities. The SWEIS accident analysis began with a detailed examination and screening of accident initiators and accident types in order to focus the attention of the remainder of the analysis on those accident initiators most important to risk. Accident initiators and accident types were identified and categorized into three broad classes: (1) process hazards, (2) man-made hazards, and (3) natural phenomena hazards (NPHs). Military action, sabotage, terrorism, or other forms of deliberately malevolent actions were not included. The magnitudes of the likelihood and consequences of such acts are independent of the site operations, under the purview of security and protection forces, and are considered to be outside the purview of accident analysis.

The list of accident types and initiators, arrayed into these three categories, is provided as Table G.3.1-1. These accident types and initiators were evaluated in the context of their likelihood and their potential for resulting in a release of hazardous materials or for causing an event that could result in such a release (e.g., a fire or explosion). Hazardous materials at LANL include radioactive materials, chemicals, biohazards, and high explosives.

The intent is to capture all accidents that have a frequency in excess of 1×10^{-6} per year. It is not possible to estimate accurately the likelihood (frequency) of accidents with very low probability. Therefore, accident types and accident initiators that could produce an accident with a frequency in excess of 1×10^{-7} per year when realistically estimated, or a

frequency in excess of 1×10^{-6} per year when conservatively estimated, were treated as “credible” and “reasonably foreseeable.”

Accidents with frequencies less than 1×10^{-6} were not dismissed without considering whether they were capable of producing worse consequences than credible accidents. Large earthquakes would affect the entire LANL site simultaneously. As a result, it is not considered plausible that many individual but unlikely accidents could rival earthquakes in overall risk, and thus, were not retained for detailed analysis.

A suite of accident type and accident initiator screening criteria was developed for the purpose of evaluating the master event list in Table G.3.1–1. It is important to recognize that, while some of the accident types or initiating events listed in Table G.3.1–1 may appear to some readers to stray into the realm of the absurd, the goal of the master listing and the screening process was to demonstrate that the consideration of accident types and accident initiators was as comprehensive as possible.

The accident types and initiators in the master list were screened, using the screening criteria in Table G.3.1–2. Results of the screening for process hazards, man-made hazards, and natural phenomena hazards are reported separately in Tables G.3.1–3, G.3.1–4, and G.3.1–5, respectively.

Table G.3.1–6 summarizes the three preceding tables as events that survived that screening. These were subsequently evaluated on a facility-specific basis, using detailed safety documentation review and facility walkdowns, as described in the following section G.3.2.

G.3.2 Facility Hazard Screening

DOE assigns different hazard categories to its facilities on the basis of the magnitude of maximum potential injuries and fatalities on site and off site. Although the system has a different

purpose than identification of facilities to be considered in EIS analyses, the past categorization constituted an effective screening of facilities for this SWEIS.

In hazard classification, no credit is given designed active safety features⁴, administrative controls (other than those limiting the total quantity of hazardous materials in the facility), or prompt emergency response. Credit for mitigation is assumed only for substantial passive primary barriers or natural removal or dispersal mechanisms associated with the distance between the facility and the receptor location (LANL 1995a). Hazard classification is therefore considered to represent an appropriate basis for an initial screening of LANL facilities to focus the attention of the SWEIS accident analysis on those facilities that have the most significant potential for causing impacts to workers, the public, and the environment.

This screening step is based on the hazard posed by the facility. There may be other reasons for including facilities in the accident analysis (e.g., stakeholder interest). Such additional facilities were selected by expert judgment. The facilities that were identified in the initial hazard categorization process are listed in Table G.3.2–1. Following detailed discussions with LANL, walkdowns of more than 40 facilities, and review of updated safety documentation, many of the facilities in Table G.3.2–1 were screened from further analysis. Table G.3.2–2 provides a listing of the facilities that were screened and a summary of the reasons for their exclusion from detailed analysis. Table G.3.2–3 provides the final list of facilities that were subjected to screening consequence analysis in

4. An “active safety feature” is one that is fallible, through its dependence upon maintenance, electrical power, human operation, etc. Examples would be a smoke alarm, filtering system or automatic electrical switch. A “passive” feature or barrier is one that does not require dependable human attention for its operation. Examples are a berm, catch basin, or firewall.

TABLE G.3.1–1.—Accident Type and Initiating Event Master Classification List

PROCESS HAZARDS	MAN-MADE HAZARDS	NATURAL PHENOMENA HAZARDS	NATURAL PHENOMENA HAZARDS (CONT.)
Biohazard Spill	Aircraft Crash ^h	Avalanche	Lightning Strike ^{bb}
Chemical Spill ^a	Arson	Barometric Pressure ^s	Liquefaction ^{cc}
Container Failure	Co-Located Facilities ⁱ	Biological Hazards ^t	Low Water Level
Criticality Event ^b	Dam Failure ^j	Blizzards ^u	Nontectonic Deformation
Explosion ^c	Dike Failure ^j	Climatic Change ^v	Precipitation Extremes
Fire ^d	Explosion ^k	Coastal Erosion	River Diversion
Flooding ^e	Fire ^l	Drought	Sand Storms
Hardware Failure ^f	Flooding ^j	Dust Storms	Seiche
Human Error ^g	Levee Failure ^j	Earthquakes ^w	Sink Holes and Collapse
Radioactive Spill	Military Action ^m	Extraterrestrial Objects ^x	Slope Stability
	Nuclear Detonation ⁿ	Fog	Snow
	Pipeline Failure ^o	Frost	Soil Consolidation
	Sabotage and Terrorism ^p	Glacial Activity ^y	Soil Shrink/Swell
	Satellite Orbital Decay	Hail	Storm Surge
	Shipwrecks	High Water ^j	Temperature Extremes ^{dd}
	Vandalism ^q	High Wind ^z	Tornadoes ^{ee}
	Transportation ^r	Hurricanes	Tsunami
		Ice and Ice Jams	Volcanism ^{ff}
		Landslides and Mudflows ^{aa}	Waves

Notes:

^a Includes release of chemicals, including toxic gases, liquids, solids, high explosives, etc. that disperse into the facility or environment. Also includes uncontrolled chemical reactions due to inadvertent mixing of chemicals (e.g., mixing of metal cyanide solution and acid, which liberates hydrogen cyanide).

^b Represents all accidental or unplanned nuclear criticality events, including criticality in solid systems, aqueous solutions, and waste forms. Does not include planned criticality during critical assembly experiments or fast burst reactor operations.

^c Represents explosions due to sources of explosive materials (gases, etc.) originating within the facility. Does not include ingestion of explosive gases into the heating, ventilation, and air conditioning (HVAC) system from outside the facility. Explosions may be accompanied by a fire.

^d Represents fires originating within a facility.

^e Represents flooding originating within a facility (due, for example, to a pipe break or an inadvertent actuation of a fire sprinkler system).

^f Includes hardware failures due to any cause (such as aging, overheating, overcooling, lubrication system failure, etc.) except military action, sabotage, terrorism, or other forms of deliberately malevolent actions.

^g Includes human errors in any phase of design, construction, fabrication, operation, maintenance, modification, design control, management, emergency response, etc.

^h Includes direct impact on the facility as well as a crash near the facility followed by the skidding of the aircraft or aircraft components into the facility. Also includes fires or explosions resulting from aircraft crash (due to combustion of aviation fuel and/or the contents of the aircraft), as well as impacts of missiles on the facility resulting from the aircraft crash or resulting fire/explosion.

ⁱ Represents accidents at nearby facilities (off-site industrial facilities, other on-site facilities, military facilities, etc.) that cause an impact at the facility under evaluation. Such accidents would include explosions, fires, chemical accidents, toxic gas releases, etc.).

TABLE G.3.1–1.—Accident Type and Initiating Event Master Classification List-Continued

- ^j Includes failures due to human errors (such as design errors, failure to anticipate sufficiently severe flood and debris conditions, construction errors, etc.).
- ^k Includes explosions from sources outside the facility, but does not include explosions due to pipeline accidents, sabotage, or military action.
- ^l Includes fires from sources outside the facility, such as wildfires.
- ^m Includes acts of war, as distinguished from sabotage, terrorism, arson, etc. Also includes war-like actions during internecine conflicts.
- ⁿ Includes only the inadvertent detonation of a nuclear explosive device. No nuclear weapons or nuclear explosive devices will be assembled, disassembled, or otherwise handled at LANL under any of the alternatives.
- ^o Includes accidents involving natural gas pipelines that can result in fires and/or explosions.
- ^p Includes acts committed by authorized insiders (persons with authorized access to the facility) or outsiders (including visitors) that are committed with the intent of causing a release of radioactive materials, hazardous chemicals, high explosives, or biohazards or that are committed with the intent of causing a nuclear criticality event. The acts could take place at the facility or outside the facility (e.g., destruction of a dam, deliberate crash of an aircraft, etc.).
- ^q Includes acts committed by authorized insiders or outsiders (including visitors) that are not intended to cause a release of radioactive materials, hazardous chemicals, high explosives, or biohazards or that are not intended to cause a criticality, but that nonetheless result in such occurrences contrary to the intent of the perpetrators.
- ^r Includes accidents resulting in release of radioactive materials, hazardous chemicals, high explosives, or biohazards, or that result in a nuclear criticality event, occurring in all modes of transportation (truck, car, rail, aircraft, or ship) that involve material being shipped to or from the facility. Also includes impact of a vehicle from all modes of transportation (except aircraft, which is analyzed separately in this appendix) on the facility that causes damage to the facility (but that may or may not be transporting hazardous cargo).
- ^s Includes normal changes in barometric pressure. Does not include changes in air pressure due to the passage of a tornado, which is analyzed separately.
- ^t Includes accidents caused by biological factors such as ingestion of plant debris by cooling systems, blockage of cooling systems by mussel and clam infestations, excessive biological growth on the exterior of facility structures, etc. Does not include fire involving plants (wildfire), which is analyzed separately.
- ^u Includes effects from excessive loads due to snow accumulation on or against facility structures.
- ^v Includes such effects as global warming (and its impacts), glaciation (and its impacts), and other impacts of changes in weather that are not within the range of normally expected conditions. Does not include impacts due to existing glaciers.
- ^w Includes effects such as seismically initiated liquefaction, dam failures, fires, and flooding, as well as surface deformation, tectonic subsidence, tectonic uplift, and damage due to ground accelerations (vertical and horizontal).
- ^x Includes direct impact on the facility of meteorites, comets, asteroids, and other extraterrestrial bodies, as well as collateral damage resulting from impacts elsewhere (surface deformation, missile impacts, flooding, etc.).
- ^y Includes impacts due to glaciers existing at the time of the analysis. Such impacts include the effects of both the advance and retreat of glaciers.
- ^z Includes straight winds, as distinguished from hurricanes and tornadoes, and also includes wind-borne missiles.
- ^{aa} Does not include landslides and mud flows due to volcanic activity.
- ^{bb} Includes the impacts of fires caused by lightning strikes. For structures with lightning protection, this requires consideration of possible failures of lightning protection systems.
- ^{cc} Does not include seismically initiated liquefaction, which is included under earthquakes.
- ^{dd} Includes effects of freezing of equipment due to low external temperatures.
- ^{ee} Includes impacts due to tornado-borne missiles, differential pressure due to nearby tornado passage, and lightning strikes, hail, rain, and other phenomena due to storms associated with the tornado weather system.
- ^{ff} Includes such effects as ash falls, rock falls, nueé ardente, rapid snow-pack-melt-induced flooding, mud flows, siltation, sedimentation, phreatomagmatism, pyroclastic activity, etc. and fire/explosion.

TABLE G.3.1–2.—Accident Type and Accident Initiator Screening Criteria

SCREENING CRITERION	SCREENING CRITERION DESCRIPTION
1	The accident type or initiating event is within the facility design basis, and the frequency in combination with the conditional probability of a sufficiently severe design error affecting parameters that would cause failure of the facility is considered to be incredible (i.e., frequency less than 1×10^{-6} per year (conservatively evaluated); or
2	The initiating event does not occur close enough to the facility to affect it (this is a function of the magnitude of the event and the proximity of the facility to the event); or
3	The accident type or initiating event is included in the definition of another event due to the similarity of impacts on the facility, and the frequency contribution of the other event includes the contribution from this event; or
4	The event has a sufficiently cataclysmic impact on the facility as well as on the surrounding region such that the consequences of the event on the surrounding region would not be significantly affected by the destruction of the facility; or
5	The accident type or initiating event has a conservatively estimated mean frequency of less than 1×10^{-6} or a realistically estimated mean frequency of less than 1×10^{-7} per year; or
6	The accident type or initiating event is under the purview of the security and protection forces and the security and safeguards related administrative and physical controls, and is the result of deliberate act; these events are considered to be outside the purview of an “accident” analysis, which is concerned with unanticipated events that occur at random.

TABLE G.3.1-3.—*Process Hazards Screening Results*

ACCIDENT TYPE OR INITIATING EVENT	SCREENING CRITERIA						SCREENS OUT (Y/N)	NOTES
	1	2	3	4	5	6		
Biohazard Spill							No	Applicable to workers only; no credible scenario for spread of biohazard beyond the LANL workforce
Chemical Spill							No	Chemical spill hazards bounded by toxic gases and liquids that are easily dispersed
Container Failure			X				Yes	Contributing event to chemical spill and radioactive spill
Criticality Event							No	Applicable to workers only; public dose consequences of criticality event are less than 100 millirem
Explosion							No	
Fire							No	
Flooding	X		X				Yes	Possible contributing cause for criticality events; criticality retained
Hardware Failure			X				Yes	Embedded in other events as contributory causes; also represented as causes of system failures after an initiating event
Human Error			X				Yes	Embedded in other events as contributory causes; also represented as causes of system failures after an initiating event
Radioactive Spill							No	

TABLE G.3.1-4.—*Man-Made Hazards Screening Results*

ACCIDENT TYPE OR INITIATING EVENT	SCREENING CRITERIA						SCREENS OUT (Y/N)	NOTES
	1	2	3	4	5	6		
Aircraft Crash							No	Analysis to be performed per DOE Standard 3014-96 (DOE 1996c)
Arson						X	Yes	Malevolent act
Co-Located Facilities							No	
Dam Failure		X			X		Yes	
Dike Failure		X			X		Yes	
Explosion							No	
Fire							No	
Flooding							No	TA-18 only; other hazardous facilities located on mesa tops
Levee Failure		X			X		Yes	
Military Action						X	Yes	Malevolent act
Nuclear Detonation					X	X	Yes	No nuclear weapons or nuclear explosive devices are assembled, disassembled, handled, or otherwise processed at LANL
Pipeline Failure							No	TA-3-29 only
Sabotage and Terrorism						X	Yes	Malevolent acts
Satellite Orbital Decay					X		Yes	
Shipwrecks		X			X		Yes	
Transportation							No	Transportation analysis performed separately from accident analysis
Vandalism						X	Yes	Malevolent acts

TABLE G.3.1-5.—Natural Phenomena Hazards Screening Results

ACCIDENT TYPE OR INITIATING EVENT	SCREENING CRITERIA						SCREENS OUT (Y/N)	NOTES
	1	2	3	4	5	6		
Avalanche		X					Yes	
Barometric Pressure	X						Yes	
Biological Hazards		X					Yes	
Blizzards	X						Yes	
Climatic Change				X			Yes	
Coastal Erosion		X					Yes	
Drought	X						Yes	
Dust Storms	X						Yes	
Earthquakes							No	
Extraterrestrial Objects					X		Yes	
Fog	X						Yes	
Frost	X						Yes	
Glacial Activity				X			Yes	
Hail	X						Yes	
High Water		X					Yes	
High Wind							No	
Hurricanes		X					Yes	
Ice and Ice Jams		X					Yes	
Landslides and Mud Flows		X					Yes	
Lightning Strike							No	
Liquefaction	X						Yes	
Low Water Level		X					Yes	
Nontectonic Deformation	X						Yes	
Precipitation Extremes	X						Yes	
River Diversion		X					Yes	
Sand Storm	X						Yes	
Seiche		X					Yes	
Sink Holes and Collapse		X					Yes	
Slope Stability							No	
Snow	X						Yes	
Soil Consolidation	X						Yes	
Soil Shrink/Swell	X						Yes	
Storm Surge		X					Yes	
Temperature Extremes	X						Yes	
Tornado					X		Yes	
Tsunami		X					Yes	
Volcanism							No	

TABLE G.3.1–6.—Credible Accident Types and Accident Initiators that Survived Early Screening

PROCESS HAZARDS
Biohazard Spill Chemical Spill Criticality Event ^a Explosion (Internal to Facility) Fire (Internal to Facility) Radioactive Spill
MAN-MADE HAZARDS
Aircraft Crash—analyzed based on DOE Standard 3014–96 (DOE 1996c) Co-Located Facilities ^b Explosion (External to Facility) ^b Fire (External to Facility) Flood (External to Facility)—TA–18 only ^b Pipeline Failure—TA–3–29 only; other facilities screened Transportation Accidents—analyzed separately from facility accidents
NATURAL PHENOMENA HAZARDS
Earthquakes High Wind ^b Lightning Strike ^b Slope Stability—TA–18 only ^b Volcanism ^c

^a Screened out for public risk based on low dose; retained as a worker accident.

^b Later screened out, based on subsequent facility- and site-specific review.

^c Credible, but not used, based on higher level of risk posed by earthquakes.

order to select the final suite of facilities for detailed analysis.

G.3.2.1 Description of the DOE Hazard Category System

As background information only, this subsection describes the hazard categorization system used by DOE.

Facilities performing radiological operations are subdivided into hazard categories pursuant to DOE Order 5480.23 and DOE Standard

1027-92 (DOE 1992). There are three hazard categories based on the type of facility (Hazard Category 1) or the radiological inventory (Hazard Categories 2 and 3). These facilities are defined as nuclear facilities. Facilities that do not meet the threshold requirements for Hazard Category 3 but that still contain radioactive materials are categorized as radiological facilities.

The three hazard categories for these facilities are defined as follows (DOE 1992):

- *Hazard Category 1.* Hazard analysis shows the potential for significant off-site consequences (limited to Category A reactors and other facilities designated by the Program Secretarial Officer). (Note: There are no facilities at LANL designated by LANL or DOE as Hazard Category 1).
- *Hazard Category 2.* Hazard analysis shows the potential for significant on-site consequences (includes facilities with the potential for nuclear criticality events or with sufficient quantities of hazardous materials and energy that would require on-site emergency planning activities). Threshold quantities of radionuclides for Hazard Category 2 facilities are shown in Appendix A of DOE Standard 1027-92 (DOE 1992), with LANL-specific elaboration provided in a separate document (LANL 1995b).
- *Hazard Category 3.* Hazard analysis shows the potential for only significant localized consequences. Threshold quantities of radionuclides for Hazard Category 3 facilities are shown in Appendix A of DOE Standard 1027-92, with LANL-specific elaboration provided in a separate document (LANL 1994a).
- *Radiological Facilities.* Facilities not meeting at least Hazard Category 3 threshold criteria but that still possess some amount of radioactive materials. No other hazard identified than normal office or laboratory environment (electrical equipment, glassware, tools, etc.).

TABLE G.3.2-1.—LANL Facilities Identified in Initial Hazard Categorization

HAZARD CATEGORY 2 NUCLEAR FACILITIES	HAZARD CATEGORY 3 NUCLEAR FACILITIES	MODERATE HAZARD CHEMICAL FACILITIES	LOW HAZARD CHEMICAL FACILITIES	FACILITIES SELECTED BASED ON JUDGMENT
TA-2-1, Omega West Reactor	TA-3-66, Sigma Facility	TA-00-1109, Chlorinator	TA-3-39, Shops Building	TA-3-30, General Warehouse
TA-3-29, Chemistry & Metallurgy Research Building	TA-3-159, Sigma Thorium Storage Facility	TA-00-1110, Chlorinator	TA-3-141, Beryllium Technology Building	TA-3-35, Press Building
Dynamic experiment activities involving Special Nuclear Materials ^a	TA-18-23, Pajarito Site Kiva #1	TA-00-1113, Chlorinator	TA-3-1698, Materials Science Laboratory	TA-3-102, Shops Building
TA-16-205 Weapons Engineering Tritium Facility	TA-18-26, Pajarito Site Hillside Vault	TA-00-1114, Chlorinator	TA-21-5, Chemistry Building	TA-3-164, Uranium Storage Building
TA-18-32, Pajarito Site Kiva #2	TA-18-116, Pajarito Site Kiva #3	TA-3-31, Chemical Warehouse	TA-21-150, Molecular Chemistry Building	TA-3-166, Wastewater Treatment Plant
TA-21-155, Tritium Systems Test Assembly	TA-18-168, Pajarito Site Solution High-Energy Burst Assembly (SHEBA)	TA-3-170, Gas Plant	TA-43-1, Health Research Laboratory	TA-9-21, Analytical Chemistry Building
TA-21-209, Tritium Science and Fabrication Facility	TA-21-146, Filter Building	TA-3-476, Toxic Gas Storage Shed	TA-59-1, Occupational Health	TA-9-23, Shops Building
TA-50-37, Radioactive Materials Research, Operations, and Demonstration Facility	TA-35-2, Laboratory	TA-14-5, Toxic Gas Storage	TA-54-39, polychlorinated biphenyl (PCB) Waste Storage	TA-11-30, Vibration Test
TA-54-229, TA-54-230, TA-54-231, and TA-54-232, Transuranic Waste Inspectable Storage Project	TA-35-27, Nuclear Safeguards Laboratory	TA-16-560, Chlorinator	TA-60-29, Pesticide Storage	TA-15-184, Pulsed High-Energy Radiation Machine Emitting X-Ray (PHERMEX)
TA-54-48, TA-54-153, TA-54-224, TA-54-226, and TA-54-286, Transuranic Waste Storage Domes	TA-48-1, Radiochemistry Facility	TA-21-3, Chemistry Building		TA-16-260, High Explosives Processing (Example)
TA-55-4, Plutonium Facility	TA-50-1, Radioactive Liquid Waste Treatment Facility	TA-21-4, Chemistry Building		TA-16-305, High Explosives Chemical Storage (Example)

TABLE G.3.2-1.—LANL Facilities Identified in Initial Hazard Categorization-Continued

HAZARD CATEGORY 2 NUCLEAR FACILITIES	HAZARD CATEGORY 3 NUCLEAR FACILITIES	MODERATE HAZARD CHEMICAL FACILITIES	LOW HAZARD CHEMICAL FACILITIES	FACILITIES SELECTED BASED ON JUDGMENT
TA-55-41, Nuclear Materials Storage	TA-50-69, Waste Characterization, Reduction, and Repackaging Facility	TA-35-213, Target Fabrication Facility		TA-16-340, High Explosives Pressing (Example)
	Isotope production activities and radiation effects experiments at the Los Alamos Neutron Science Center (LANSCC) ^b	TA-46-340, Wastewater Treatment Facility Chlorination Building		TA-41-1, Ice House
	TA-54-38, Radioassay and Nondestructive Testing Facility	TA-54-216, Legacy Toxic Gas Storage		TA-46-154, Applied Photochemistry
	TA-55-185, Transuranic (TRU) Drum Staging Facility	TA-54-1008, Chlorinator		
		TA-72-3, Chlorinator		
		TA-73-9, Chlorinator		

^a Activities utilize or occur at several host facilities at which special nuclear material associated with Hazard Category 2 may reside for short durations. These host facilities include TA-8-23 (Radiography), TA-16-411 (Assembly Building), and TA-15 (PHERMEX), and the DARHT facility when it is completed.

^b LANSCC, TA-53, is a nonnuclear facility that hosts several activities typically of limited duration that are considered to be Hazard Category 3, including isotope production and experiments using small quantities of actinides. The risks associated with these occasional, short duration activities involving these materials at these facilities have been evaluated in DOE safety analyses and controls are in place while the material is in the facilities.

TABLE G.3.2-2.—LANL Facilities Screened from Analysis, with Screening Rationale

FACILITY	FACILITY NAME AND SCREENING RATIONALE
TA-0-1113	Potable Water Chlorinator—Located in canyon; chlorine is a heavy gas that in high concentrations will proceed down the canyon, away from populated areas; no unique worker accidents; no biohazards; no radioactive materials.
TA-0-1114	See TA-0-1113.
TA-2-1	Omega West Reactor—Not scheduled for operation in a SWEIS alternative. All nuclear material has been moved from this facility, and the facility has been removed from the site's nuclear facility list.
TA-3-30	General Warehouse—No radioactivity or biohazards; chemical inventory screened; no unique worker hazards.
TA-3-31	Chemical Warehouse—No radioactivity or biohazards; chemical inventory screened; no unique worker hazards.
TA-3-35	Press Building—Radiological facility only; radiological hazards bounded by other nearby facilities. No chemicals or biohazards. No unique worker hazards.
TA-3-39	Shops Building—No unique worker hazards; no biohazards. Impacts from depleted uranium or beryllium bounded by other facilities (TA-3-66, TA-3-141).
TA-3-102	See TA-3-39.
TA-3-141	Beryllium Technology Building—No credible public accidents. No biohazards; no radioactivity.
TA-3-142	Shipping and Receiving Warehouse—Transient radioactivity only (less than Hazard Category 3 quantities). Chemical inventory screened (ERPG-3 < 100 meters). No biohazards. No unique worker hazards.
TA-3-159	Sigma Thorium Storage Facility—Facility contains only thorium; consequences bounded by other facilities; passive storage only, nonpyrophoric forms, low combustible loading.
TA-3-164	Uranium Storage Facility—Inventory removed. No use projected for any SWEIS alternative.
TA-3-166	Wastewater Treatment Plant—Chlorine inventory removed; facility no longer treats wastewater. No biohazards or radioactivity. No unique worker hazards.
TA-3-170	Compressed Gas Processing Facility—No radioactivity or biohazards. No unique worker hazards. Chemical inventory screened (ERPG-3 < 100 meters).
TA-3-1698	Materials Science Laboratory (MSL)—No credible accidents; radioactivity and chemical inventories screen. No unique worker hazards; no biohazards.
TA-8-22	Radiography—Facility performs radiography of (among other things) pits and DARHT assemblies. Low combustible loading and similar seismic resistance to other facilities at which these materials will be present for a much greater percentage of the time. The risks of accidents at TA-8-22 are bounded by the risks of accidents at the other facilities. No unique worker accidents (radiography performed at other facilities as well).
TA-8-23	See TA-8-22.
TA-9-23	Shops Building—Radiological inventory below Hazard Category 3; chemical inventory screens (ERPG-3 < 100 meters). No biohazards. No unique worker hazards. Remote location.

TABLE G.3.2-2.—LANL Facilities Screened from Analysis, with Screening Rationale-Continued

FACILITY	FACILITY NAME AND SCREENING RATIONALE
TA-9-30	Nuclear Material Storage—Maximum radiological inventory is 100 kilograms of depleted uranium and less than 0.1 grams of tritium (less than Hazard Category 3). Chemical inventory screens (ERPG-3 < 100 meters). No biohazards. No unique worker hazards. Remote location; depleted uranium accident consequences bounded by other facilities with greater inventory and in more densely populated area.
TA-11-30	Vibration Test Building—Transient radiological inventory only (same materials present at other facilities in greater quantity and/or more frequently). No chemicals or biohazards. No unique worker hazards.
TA-14-5	Toxic Gas Storage Building—Inventory removed. No use projected for any SWEIS alternative.
TA-15-184	PHERMEX—Firing site with no unique hazards (any hazards at PHERMEX bounded by those at DARHT and other facilities). No unique worker hazards. No biohazards. More remote than other facilities with similar MAR.
TA-16-260	High Explosives Processing—No radioactivity or biohazards. No unique worker hazards. Detonation hazards limited to workers due to exclusion area and blowout panels.
TA-16-305	High Explosives Chemical Storage—No radioactivity or biohazards. No unique worker hazards. Chemical inventory screens (ERPG-3 < 100 meters). Contained in former high explosives magazine.
TA-16-340	High Explosives Pressing Facility—No radioactivity or biohazards. No unique worker hazards. Detonation hazards limited to workers due to exclusion area and blowout panels.
TA-16-410	Assembly Facility—Activities at TA-16-410 are comparable to those at TA-16-411, and the MAR at TA-16-410 is bounded in hazard and quantity by MAR at TA-16-411.
TA-16-560	Potable Water Chlorinator—Consequences limited to area containing few buildings. No public consequences (except possibly a limited number of commuters on West Jemez Road). No unique worker hazards; no biohazards; no radioactivity. Impacts bounded by other potable water chlorinators.
TA-18-26	Pajarito Site Hillside Vault—Passive vault storage of plutonium and highly enriched uranium (HEU) in a vault built into the side of a mesa. Very low combustible loading, no active HVAC systems. Infrequent access. Seismic collapse would bury MAR with no significant release to the environment. No credible accidents; very low frequency accidents bounded by those at other storage facilities (TA-3-29, TA-55-4).
TA-21-3	Chemistry Building—Facility undergoing decontamination and decommissioning; completion scheduled prior to final SWEIS issuance.
TA-21-4	See TA-21-3.
TA-21-5	See TA-21-3.
TA-21-146	Filter Building—Filter building for former plutonium activities at TA-21. Decontamination and decommissioning will be completed prior to final SWEIS issuance.
TA-21-150	See TA-21-3.
TA-35-2	Laboratory—The only MAR is radioactive sources, which screen under DOE Standard 1027-92 (DOE 1992).
TA-35-27	Nuclear Safeguards Laboratory—The only MAR is radioactive sources, which screen under DOE Standard 1027-92.

TABLE G.3.2-2.—LANL Facilities Screened from Analysis, with Screening Rationale-Continued

FACILITY	FACILITY NAME AND SCREENING RATIONALE
TA-35-213	Target Fabrication Facility—No radioactive materials (except less than Hazard Category 3 quantities of depleted uranium and tritium). No biohazards. Some toxic chemicals present, but located in fume hoods with active ventilation. Under seismic collapse conditions, toxic effects remain within TA (facility adjacent to canyon, which will preclude transport of high concentrations of heavy gases); workers would be impacted by the seismic collapse in any event.
TA-41-1	Ice House—Former radiological inventory removed (residual contamination only). No storage or processing in any SWEIS alternative. No chemicals or biohazards. No unique worker hazards.
TA-46-154	Applied Photochemistry—No radioactivity or biohazards. No unique worker hazards. Chemical inventory screens (ERPG-3 < 100 meters).
TA-48-1	Radiochemistry Facility—All MAR (radioactive and chemical) screen (i.e., radioactivity less than Hazard Category 3, except for hot cells; chemicals screen at ERPG-3 at less than 100 meters). Any impacts would be limited to the TA-48 site area.
TA-53	LANSCE and Manuel Lujan Neutron Scattering Center (MLNSC)—No credible accidents. No unique worker accidents. No biohazards.
TA-54-33	Drum Preparation Facility—No chemicals or biohazards. No unique worker hazards. MAR limited and bounded by other nearby facilities (TA-54-38, TA-54-G Transuranic Waste Inspectable Storage Project [TWISP]).
TA-54-49	Low-level Mixed Waste Storage Dome—No biohazards. No unique worker hazards. Radiological hazards bounded by other nearby facilities with much larger inventories (TA-54-G, TWISP).
TA-54-1008	Potable Water Chlorinator—No receptors within ERPG-2 distance. No unique worker hazards; no biohazards or radioactivity.
TA-55-5	Plutonium Facility Warehouse—Chemical inventory removed; staging area only with transitory chemical inventory. No changes expected for any SWEIS alternative. Bounded by TA-55-4 chemical accidents (e.g., chlorine, hydrogen fluoride gas, nitric acid, hydrochloric acid).
TA-55-41	Nuclear Materials Storage Facility (NMSF)—Storage activities at TA-55-41 mirror those at TA-55-4. No unique hazards at TA-55-41. TA-55-41 connected to TA-55-4 via an underground tunnel. Risks at TA-55-41 bounded by those at TA-55-4.
TA-60-29	Pesticide Storage Building—Passive storage facility; chemicals screen or are bounded by the effects of chemical releases at other nearby facilities. No biohazards or radioactivity.
TA-72-3	Potable Water Chlorinator—No receptors within ERPG-2 distance. No unique worker hazards; no biohazards or radioactivity.
TA-73-1	Los Alamos Airport—Covered under transportation accident analysis. Aircraft crash associated with missed landings, etc., covered in facility aircraft crash accident analysis (DOE Standard 3014-96, DOE 1996b).
TA-73-9	Potable Water Chlorinator—Located on steep hill. Chlorine is a heavy gas that in high concentrations will proceed downhill into a canyon. Any impacts to commuters on State Road 502 will be bounded by chlorine release from other potable water chlorinators (TA-0-1109, TA-0-1110).

TABLE G.3.2-3.—Final List of LANL Facilities to be Subjected to Screening Consequence Analysis

TECHNICAL AREA AND BUILDING NUMBER	FACILITY NAME
TA-0-1109	Potable Water Chlorinator
TA-0-1110	Potable Water Chlorinator
TA-3-29	CMR Building
TA-3-66	Sigma Facility
TA-3-476	Toxic Gas Storage Shed
TA-9-21	Analytical Chemistry Building (worker hazard only)
TA-15-312	DARHT Facility
TA-16-205	WETF
TA-16-411	Assembly Building
TA-18-23	Pajarito Site Kiva #1 (seismic and aircraft crash only)
TA-18-32	Pajarito Site Kiva #2 (seismic and aircraft crash only)
TA-18-116	Pajarito Site Kiva #3
TA-18-168	Pajarito Site SHEBA Building (seismic and aircraft crash only)
TA-21-155	TSTA
TA-21-209	TSFF
TA-43-1	Health Research Laboratory (HRL) (seismic only)
TA-46-340	Waste Water Treatment Facility (WWTF)
TA-50-1	Radioactive Liquid Waste Treatment Facility (seismic only)
TA-50-37	Radioactive Materials Research, Operations, and Demonstration Facility (RAMROD)
TA-50-69	Waste Characterization, Reduction, and Repackaging (WCRR) Facility
TA-54-G	TWISP (TA-54-229, TA-54-230, TA-54-231, and TA-54-232); Transuranic Waste Storage Domes (TA-54-48, TA-54-153, TA-54-224, TA-54-226, and TA-54-283); Tritium Waste Sheds (TA-54-1027, TA-54-1028, TA-54-1029, and TA-54-1041)
TA-54-38	Radioactive Assay and Nondestructive Test (RANT) Facility
TA-54-39	PCB Waste Storage Facility
TA-54-216	Legacy Toxic Gas Storage Facility
TA-55-4	Plutonium Facility
TA-55-185	Transuranic Waste Drum Staging Building
TA-59-1	Occupational Health Laboratory (worker hazard only)

Facilities that do not perform radiological operations are subdivided into three hazard classes based on the hazard potential of the chemical inventory according to guidance in DOE Order 5481.1B and DOE EM Standard 5502-94 (DOE 1994b). Facilities that do not fall into one of the three hazard classes are considered as nonhazardous facilities (i.e., no hazards identified other than a normal office environment) (LANL 1995a).

The four nonnuclear facility hazard classes are defined as follows (DOE 1994b):

- *High Hazard.* Hazards with a potential for on-site and off-site impacts to large numbers of people or for major impacts to the environment. (Note: There are no facilities at LANL designated by LANL or DOE as High Hazard).
- *Moderate Hazard.* Hazards that present considerable potential on-site impacts to people or the environment but at most only minor off-site impacts.
- *Low Hazard.* Hazards that present minor on-site and negligible off-site impacts to people and the environment.
- *Nonhazardous.* No hazards beyond those routinely encountered in an office environment (electrical equipment, glassware, tools, etc.).

G.3.2.2 Use of Facility Safety Documentation and Walkdowns

Based on the results of the accident initiator screening and facility screening, available facility safety documentation was reviewed. All other things being the same, potential accident scenarios with the largest release potential within each frequency row were selected for more detailed review and assessment. Prior to the conduct of facility interviews and walkdowns (in most cases), a preliminary list of accident scenarios was prepared based on

facility safety documentation review in order to facilitate the walkdown and discussions with facility operations personnel.

A pre-visit facility walkdown/interview data collection form was prepared for each facility and transmitted to facility representatives (through the LANL SWEIS Project Office). Facility representatives, in coordination with the LANL SWEIS Project Office points-of-contact, then arranged for a facility discussion and walkdown. The walkdown/interview data collection forms were created to facilitate the collection of a consistent set of facility data. In preparing the forms, the previous experience of SWEIS accident analysis team in conducting previous accident evaluations (including safety analyses, probabilistic risk assessments, and process hazard analyses) was considered. In addition, the following specific source documents were considered:

- DOE Handbook 1100-96, *Chemical Process Hazard Analysis*, February 1996 (DOE 1996b).
- DOE EM Standard 5502-94, *Hazard Baseline Documentation*, August 1994 (DOE 1994b).
- DOE Standard 1027-92, *Hazard Categorization and Accident Analysis Techniques for Compliance with DOE Order 5480.23, Nuclear Safety Analysis Reports*, December 1992 (DOE 1992).
- DOE Standard 3009-94, *Preparation Guide for U.S. Department of Energy Nonreactor Nuclear Facility Safety Analysis Reports*, July 1994 (DOE 1994a).

During and subsequent to the walkdowns, revised safety documentation was provided by the facility representatives. This documentation was subsequently reviewed, and a draft data collection document was prepared for each facility. These draft data collection documents were reviewed by the LANL SWEIS Project Office and facility representatives to ensure that the information about the facilities and their

operation was correctly noted by the data collection team.

Where a facility had current safety documentation, that documentation was used in the first instance to define accident scenarios. Owing to differences in scope between safety documentation and NEPA accident analyses, some supplementation of the safety documentation was necessary in a few instances in order to provide the required NEPA coverage (this was especially true in the area of seismically initiated sequences). The facility walkdowns were used to further evaluate the accident scenarios identified in the safety documentation, to evaluate whether additional accident scenarios were possible that were not included in the safety documentation, to evaluate whether there were accident frequency or accident consequence mitigation capabilities present that were not credited in the safety documentation, and to assess the impacts of the SWEIS alternatives on the accident scenarios. This latter consideration included the following aspects:

- Evaluation of whether accident frequencies could increase or decrease across the alternatives
- Evaluation of whether the MAR could increase or decrease across the alternatives
- Evaluation of whether accident scenarios identified for the No Action Alternative would be eliminated across the remaining alternatives
- Evaluation of whether any accident scenario not identified for the No Action Alternative would be possible in any of the other alternatives

As a result of the facility walkdowns and interviews and the review of revised safety documentation for many facilities, a large number of credible radiological accident scenarios were identified and grouped by MAR (e.g., weapons grade plutonium, source material plutonium, tritium, highly enriched uranium,

depleted uranium, etc.) for further consideration.

G.3.2.3 *Population Distributions*

Population distributions were created (using the SECPOP90 program) based on 1990 Census data for residential population and based on 1996 LANL workforce populations by TA.

LANL workforce populations were included in the analysis by centering the total TA population in the direction from the accident origination facility that represents the largest concentration of TA population for each TA. Although this is an approximation method and results in some double counting because facility workers also may have residences within the 50-mile (80-kilometer) radius of LANL for which consequence calculations were performed, this is believed to be an appropriate means for including LANL workforce consequences.

The aggregation of workforce population data by TA is the only available aggregation for which substantial questions do not exist. Although data are available on a building-by-building basis, those data represent where the LANL employees collect their mail and do not necessarily represent where they spend most of their work day. Neither is the LANL workforce varied across the alternatives for accident analysis purposes, although it is recognized that the LANL workforce varies in size by alternative. There is much greater variation in LANL workforce from shift to shift during any given day than there is across the alternatives. It is not practical nor feasible to refine the population within a TA quite close to a release point because such data are not available and would not be stable. The consequences are given in terms of collective exposure and the exposure at the MEI locations, which are adequate for differentiating among the alternatives for decision making.

In all cases in this accident analysis, the accidents are assumed to take place during the day shift with the maximum workforce population present. (Indeed, the entire workforce is represented in the aggregated workforce population data by TA, not just the daytime workforce.) The assumption of daytime conditions is conservative for those accidents that occur at random and are unrelated to processes in operation at any given time.

G.3.2.4 *Dispersion Parameters Used in Screening and Consequence Calculations*

Daytime populations, which are larger than nighttime populations near the source, were used for screening and calculating the consequences of chemical and radiological accidents. Accordingly, the meteorological conditions used were: (1) wind speed of 9.2 feet per second (2.8 meters per second); (2) Pasquill-Gifford stability Class C; (3) ambient temperature of 48°F (8.9°C); (4) mostly sunny, cloud cover conditions; and (5) 51 percent relative humidity. These are representative of daytime conditions in this area (LANL 1990a). They provide conservative dispersion under daytime conditions and will be referred to as such in this SWEIS. (Class A and B stabilities also occur during the daytime, but their greater vertical air motions will produce lower ground level concentrations. Stable atmospheres, which will produce higher concentrations, can occur but are atypical and therefore not used for screening.)

For the consequence assessment of chemical accidents, both conservative daytime dispersion and adverse dispersion conditions (stable atmosphere) were used. For radiological accidents, all meteorological conditions, in the relative frequency as they occurred in 1995, were used.

G.3.3 Chemical Accident Screening

G.3.3.1 *Summary of Chemical Accident Screening*

Thirty-seven chemicals were identified in the 1992 LANL database that met all of the following criteria:

- Has a time-weighted-average (TWA) less than 2 parts per million
- Is found in readily dispersible form (i.e., a gas or liquid)
- Has a boiling point less than 212°F (100°C) and vapor pressure greater than 0.5 millimeter mercury

These 37 chemicals were modeled for release of their largest 1992 inventory, using adverse dispersion conditions. The ten releases that exceeded the ERPG-3 guideline at 328 feet (100 meters) distance were retained for further analysis. To these were added another eight chemicals of interest.

Releases of the actual inventories of these 18 chemicals at 78 locations were then modeled to see which would exceed the ERPG-3 concentration under conservative daytime dispersion conditions. In this modeling:

- Release was at surface level
- Gases were released over 10 minutes
- Liquids were spilled instantaneously and then evaporated from a puddle 0.4 inch (1 centimeter) deep

The releases that exceeded the ERPG-3 concentration were examined with consideration of:

- Whether there is a large workforce nearby or if there is public exposure
- If a heavy gas, whether the public is protected by intervening canyons

- Whether the consequences are less than a release of the chemical from a different facility
- Whether the consequences are less than those of another chemical released from the same facility

With these considerations, a number of releases were selected and retained for detailed analysis. Formaldehyde also was retained because it represents the largest LANL inventory of a readily dispersible chemical carcinogen. These final selections are shown in Table G.3.3.1–3. The above process is described in detail in the following.

Details of Chemical Screening

There is a wide variety of chemicals in storage and in use at LANL facilities. This analysis assumes that all chemicals that are regulated or have established exposure guidelines are listed in the MULTUS database (Dukes 1995). This commercially available database contains information on over 2,800 controlled chemicals and over 23,000 associated synonyms. Because there are far more TWAs than other guidelines for chemicals, TWAs were chosen to represent toxicity for screening purposes. An upper threshold value of 2 parts per million was selected because it is the TWA for nitric acid. (There is a 6,100-gallon [23,100-liter] nitric acid tank at TA-55 that, because of its volume, was likely to represent the bounding consequence chemical accident.) The MULTUS database was searched for chemicals with TWAs less than 2 parts per million, resulting in a list of 330 chemicals.

The 1992 LANL Automated Chemical Inventory System (ACIS) chemical database (which represented LANL baseline data) was searched for these same 330 chemicals. Only 190 were found. Of these, if the chemical is ordinarily in solid form (nondispersible), it was screened from further analysis. (Although particles smaller than about 10 micrometers diameter are respirable, a liquid or gas is

expected to have greater consequences in terms of area of impact and time urgency; thus, the analysis was focused on liquids and gases.) Application of this criterion reduced the list to 74 chemicals.

If the chemical has a boiling point of greater than 212°F (100°C) and has a vapor pressure of less than 0.5 millimeters of mercury under ambient conditions, the material was screened from further analysis. This criterion was developed based on an American Conference of Governmental Industrial Hygienists (ACGIH 1992) hazard index (HI) (which assigns a low vaporization/dispersion hazard to materials with boiling points greater than 212°F [100°C]) and the EPA List of Regulated Substances and Thresholds for Accidental Release Prevention. (The latter establishes a criterion of a vapor pressure of less than 0.02 inch [0.5 millimeter] of mercury under ambient conditions for toxic liquids to capture most substances that have a relatively low volatility but may still pose an airborne hazard in accidental release [40 CFR 68].) Application of this criterion further reduced the list to 37 chemicals.

For each of the 37 chemicals, ALOHA™ dispersion modeling was performed using its largest inventory in the 1992 ACIS database. Adverse dispersion conditions were used to determine whether concentrations as great as ERPG-3 would occur at a distance of 328 feet (100 meters) (the approximate distance to noninvolved workers and general public access). Ten chemicals were found to produce ERPG-3 concentrations at distances beyond 328 feet (100 meters): boron trifluoride, bromine, chlorine, formaldehyde, methyl hydrazine, nitric acid, phosgene, phosphorous oxychloride, selenium hexafluoride, and thionyl chloride.

In addition to the ten chemicals to survive the above screening process, the following seven chemicals were identified in the “significant chemicals in hazard analysis” table of the

LANL hazard assessment document (LANL 1995a), and were included for analysis: diborane, fluorine, hydrogen cyanide, hydrogen fluoride, nickel carbonyl, perfluoroisobutylene, hydrochloric acid, and sulfur dioxide. In addition, a review of the TA-3-170 Compressed Gas Processing Facility inventory resulted in the addition of nitric oxide to the list of chemicals of concern.

An information request was submitted to LANL for storage locations, quantities, physical form, units of measurement, and other associated information for these 18 chemicals. Upon receipt of the information from LANL, the materials were aggregated into storage locations, converted into common units of measurement, and adjusted for concentration. This process resulted in 183 chemical sources at 78 storage locations. The resulting chemical inventories were then modeled to determine which facilities contained total quantities that, if released, would exceed ERPG-3 concentrations at 328 feet (100 meters) under conservative daytime atmospheric dispersion conditions. This modeling identified chemical sources at the storage locations shown in Table G.3.3.1-1.

The initial data source, as indicated above, was the 1992 ACIS baseline data. The following information sources were utilized to find additional storage locations and potential release sites for these chemicals:

- The 1995 ACIS Database, which contains a listing of the chemicals ordered on an annual basis
- TA-54 Area L (hazardous waste management facility) gas cylinder inventory
- STORES Database
- Cheaper Database (recycled chemicals) and Gas Plant Database
- Facility-Specific SARs, Safety Assessments (SAs), and other safety documentation

**TABLE G.3.3.1-1.—Preliminary ALOHA™
Chemical Screening Results**

CHEMICAL	LOCATION
Sulfur Dioxide	TA-54-216
Hydrochloric Acid	TA-55-249
Hydrogen Cyanide	TA-3-66
Nitric Acid	TA-50-1
	TA-50-5
	TA-55-4
	TA-59-1
Selenium Hexafluoride	TA-54-216
Chlorine	TA-00-1109
	TA-00-1110
	TA-00-1113
	TA-00-1114
	TA-3-476
	TA-16-560
	TA-33-200
	TA-46-340
	TA-54-1108
	TA-55-4
TA-72-3	
TA-73-9	
Fluorine	TA-54-216
Hydrogen Fluoride	TA-54-216
	TA-55-4

- LANL Spill Prevention, Control and Countermeasure (SPCC) Plan
- Facility interview and walkdown data collection forms

The results in Table G.3.3.1-1 were examined with a further consideration of population distributions surrounding the release sites and, for heavy gases, consideration of whether the potential atmospheric transport to populated areas would be interrupted by canyons. Based on these considerations, a number of release sites were screened from further consideration. The results of this initial binning effort are shown in Table G.3.3.1-2.

The release sites and chemicals surviving this initial binning effort were then plotted on a map

TABLE G.3.3.1-2.—*Preliminary Binning of Chemical Accident Release Sites*

CHEMICAL	RELEASE SITE	PRELIMINARY BINNING COMMENTS
Chlorine	TA-00-1109	Retained for detailed analysis; located on the edge of a neighborhood
	TA-00-1110	Retained for detailed analysis; located on the edge of a neighborhood
	TA-00-1113	Screened; located in a canyon; any impacts bounded by TA-0-1109/1110
	TA-00-1114	Screened; located in a canyon; any impacts bounded by TA-0-1109/1110
	TA-03-476	Retained for detailed analysis; large LANL workforce nearby; intervening canyon prevents heavy gas transport to Los Alamos townsite
	TA-16-560	Screened; located at a site with no public receptors; impacts bounded by TA-03-476
	TA-33-200	Screened; located at a remote site with no public receptors and a very small LANL workforce population (less than 10); impacts bounded by TA-03-476
	TA-46-340	Screened; no credible accidents; release site is in a canyon; heavy gas plume will dissipate prior to reaching distant public receptors
	TA-54-1008	Screened; located at a remote site with no public receptors; impacts bounded by other chemicals released from TA-54-216 (closer to LANL workforce)
	TA-55-4	Retained for detailed analysis; intervening canyon prevents transport to public receptors; large LANL workforce population (TA-35, TA-48, TA-50, & TA-55)
	TA-72-3	Screened; located at a remote site with no public receptors; canyon prevents transport of a heavy gas to populated areas
TA-73-9	Screened; located on a hill; heavy gas transport will be predominantly downslope into a canyon, away from public receptors and LANL workforce at TA-00 locations	
Fluorine	TA-54-216	Screened; impacts bounded by sulfur dioxide and selenium hexafluoride
Hydrochloric Acid	TA-55-249	Retained for detailed analysis
Hydrogen Cyanide	TA-03-66	Retained for detailed analysis
Hydrogen Fluoride	TA-54-216	Screened; impacts bounded by sulfur dioxide and selenium hexafluoride
	TA-55-4	Screened; bounded by release of chlorine at the same site
Nitric Acid (80%)	TA-50-1	Screened; impacts bounded by chlorine and nitric acid release at TA-55-4
	TA-50-5	Screened; impacts bounded by chlorine and nitric acid release at TA-55-4
	TA-55-4	Retained for detailed analysis (large LANL workforce population at TA-55)
	TA-59-1	Screened; largest container is 2.6 gallons, bounded by much larger potential releases at other facilities
Selenium Hexafluoride	TA-54-216	Retained for detailed analysis
Sulfur Dioxide	TA-54-216	Retained for detailed analysis; other sites screened, bounded by release at TA-59-216

of Los Alamos County and evaluated based on the population grids (on-site and off-site) surrounding the respective chemical storage location. The population distributions for chemical release sites were generated from 1990 Census data and current LANL TA populations as described above. The evaluation considered the probability that the wind would blow in the direction of the population at the time of release.

In addition, the chemical storage locations were separated into the following bins relating to the potential accident scenario: natural phenomena hazards (e.g., seismic events), process hazards, and man-made hazards. This final binning effort is portrayed in Table G.3.3.1–3.

Formaldehyde at TA–43–1, which was originally screened as resulting in concentrations less than ERPG–3 at 328 feet (100 meters) under conservative daytime dispersion conditions, was added back to the list on the basis that it represents the largest LANL

inventory of a readily dispersible carcinogen from the 51 confirmed, suspected and animal carcinogens in the site inventory.

G.3.3.2 Assumptions Inherent in the Screening

The following assumptions are inherent in the process:

- All hazardous LANL chemicals are in the MULTUS database.
- All hazardous LANL chemicals of significant inventory are in the LANL ACIS database or otherwise captured in the safety documentation and walkdowns.
- There are no readily dispersible particles that pose significant accident release consequence and that are not otherwise captured in the human health analyses and/or in the site-wide and other accident scenarios.

TABLE G.3.3.1–3.—Final Chemical Accident Binning

CHEMICAL	RELEASE SITE	PROCESS HAZARD	MAN-MADE HAZARD	NATURAL PHENOMENA HAZARD	CARCINOGEN
Chlorine	TA–00–1109	X		X	
	TA–00–1110	X		X	
	TA–03–476		X		
	TA–55–4	X		X	
Formaldehyde	TA–43–1			X	X
Hydrochloric Acid	TA–55–249			X	
Hydrogen Cyanide	TA–03–66			X	
Nitric Acid	TA–55–4			X	
Selenium Hexafluoride	TA–54–216	X	X		
Sulfur Dioxide	TA–54–216	X	X		

Note: These releases are heavy gas releases except for selenium hexafluoride and hydrogen chloride. Heavy gases in high concentrations would not be capable of crossing canyons from mesa to mesa, but would instead flow down into the canyons and proceed downslope. Such diversion into canyons is not modeled by ALOHA™, which is a flat terrain model. Heavy gas behavior has been taken into account manually in the affected population results shown above. The formaldehyde release from TA–43–1 was screened on chemical consequence results. However, it was retained because it represents the largest inventory of a readily dispersible carcinogenic chemical.

- There are no solid (nondispersible) pyrophoric materials posing a release hazard of significant consequence that were not captured or bounded in one of the accidents considered.
- Gases were modeled as a 10-minute release (rather than an instantaneous release) in accordance with the EPA *Risk Management Plan Off-site Consequence Analysis Guidance* (EPA 1996) and the EPA/FEMA/ DOT *Technical Guidance For Hazards Analysis* (EPA 1987). However, instantaneous release may be possible for some gases, producing much higher concentrations (though for a shorter time).
- The terrain around LANL facilities is relatively flat in the first several hundred meters, and when not, this does not dramatically change the concentrations from those produced by ALOHA™.
- The surface around LANL facilities is represented by the surface roughness in the ALOHA™ model, which in turn affects the dispersion rate.
- The averaging time inherent in ALOHA™ does not smooth, to an average less than 2 parts per million, dangerously high momentary concentrations that would exist beyond 328 feet (100 meters).

These assumptions are reasonable for screening because the resultant screening is sufficiently conservative to have a reasonable assurance of capturing all chemicals and chemical locations that pose a risk to the public and workers outside the facility.

G.3.4 Facility Radiological Accident Screening

G.3.4.1 Methodology for Consequence Screening

To facilitate radiological facility accident screening, integrated population exposure was established as an evaluation criterion.

Consequences were calculated for the release of a unit of material and multiplied by the source term magnitude to obtain approximate consequences for screening. The calculations were performed with the MACCS 2 code (as described in section G.2.4) for both ground level releases and elevated releases (which varied from 18.3 to 100 meters, depending on the facility and the scenario of interest). The following distance intervals were used in each of the 16 compass directions: 0 to 1 kilometer, 1 to 2 kilometers, 2 to 3 kilometers, 3 to 4 kilometers, 4 to 8 kilometers, 8 to 12 kilometers, 12 to 20 kilometers, 20 to 30 kilometers, 30 to 40 kilometers, 40 to 60 kilometers, and 60 to 80 kilometers.

G.3.4.2 Source Terms

For radiological accidents, there are two source terms of interest: the initial source term and the suspension source term. The initial source term is the radioactive material driven airborne at the time of the accident. The suspension source term is the radioactive material that becomes airborne subsequent to the accident as a result of evaporation, winds, or other processes. For most DOE nonreactor facilities, the dose from inhalation exposure dominates the overall dose from accidents.

Source terms were estimated based on the accident progression for the scenario being considered. DOE Handbook 3010-94, *Airborne Release Fractions/Rates and Respirable Fractions for Nonreactor Nuclear Facilities* (DOE 1994d), was used as the primary reference for calculation of source terms. DOE Standard 3014-96 (DOE 1996c), which covers aircraft crash accidents, has a separate source term methodology identified in Table II of the standard. Although it is stated to be based on DOE Handbook 3010-94, it is more conservative than the handbook. In order to maintain consistency across the accident analyses, and in accordance with the provision in Section 7.2.5 of the DOE standard, which

provides that other methods can be used if justified, the DOE Handbook 3010-94 source term methodology has been applied to the aircraft crash accidents in this SWEIS.

MAR estimates were obtained from safety documentation and verified during the course of facility walkdowns. Two source term equations are used: one for the initial source term and one for the subsequent continuing suspension source term. The initial equation has the following general form:

$$\text{Initial Source Term} = (\text{MAR}) \times (\text{DR}) \times (\text{ARF}) \times (\text{RF}) \times (\text{LPF})$$

where:

MAR = Material-at-risk (quantity of material available to be acted on by a given physical stress)

DR = Damage ratio (the fraction of the MAR actually impacted by the accident-generated conditions)

ARF = Airborne release fraction (the fraction of the material suspended in the air as an aerosol and, thus, available for transport due to the physical stresses from a specific accident or due to operation of HVAC systems)

RF = Respirable fraction (the fraction of the aerosols that can be transported through the air and inhaled into the human respiratory system, commonly assumed to include particles of 10 micrometers aerodynamic equivalent diameter or less)

LPF = Leak path factor (the fraction of the respirable aerosols transported through some confinement or filtration mechanism)

The suspension source term equation has the following general form:

$$\text{Suspension Source Term} = (\text{MAR}) \times (\text{DR}) \times (\text{ARR/hr}) \times (24 \text{ hrs}) \times (\text{RF}) \times (\text{LPF})$$

where:

MAR = Material-at-risk

DR = Damage ratio

ARR/hr = Airborne release rate per hour

RF = Respirable fraction

24 hrs = Suspension calculational time period

LPF = Leak path factor

Note that the suspension source term includes all processes whereby material continues to become airborne. This includes evaporation of liquids, continuing leaks, and resuspension by air motions of material initially deposited. It is referred to as "suspension" to delineate it from resuspension, a term reserved for resuspension of deposited materials previously airborne.

G.3.4.3 Identification of Accident Scenarios

Two primary types of data sources were used for radiological accident analysis: (1) safety documentation, including SAs, hazard analyses (HAs), process hazard analyses (PrHAs), PRAs, and SARs; and (2) facility walkdown/interview data collection forms. Documentation relied upon for the radiological facility accident analysis included the following:

- The draft facility descriptions and hazard classification document for LANL, prepared by the LANL SWEIS Project Office (LANL 1995a)
- Descriptions of alternatives for key facilities prepared by the LANL SWEIS Project Office (LANL 1997c and LANL 1998a)
- The LANL seismic hazard evaluation (Wong et al. 1995)
- The LANL aircraft crash hazard evaluation (LANL 1996c)

- Various LANL memoranda and miscellaneous documentation
- Basis for Interim Operation, Operational Safety Requirements, and Technical Safety Requirements for various LANL facilities
- Environmental Assessments (EAs) and EISs
- Various DOE guidance documents
- DOE orders and standards
- Other nuclear industry data sources (e.g., Swain and Guttman 1983 and Mahn et al. 1995)

Based on the results of the review of facility safety documentation and the facility walkdown/interview data collection process, a large suite of accident scenarios were identified and their consequences quantified by conservative screening methods. Table G.3.4.3–1 provides a consolidated listing of all of the various scenarios that were subjected to the conservative consequence screening analysis. Only those scenarios that were shown on a conservative screening basis to be potentially risk-dominant were then subjected to a more detailed analysis. (These are listed in Table G.4–1).

G.3.4.4 Addition of Site-Wide Wildfire to Screening Results

In the screening methodology, wildfire was not put into the list of natural phenomena hazards that might initiate accidents. Instead, the DOE initially treated wildfire as a subset of manmade fires (Table G.3.1–1). Manmade fires were considered at individual facilities, but were eliminated as the most frequent accident initiator, or the bounding or representative accident for the facility. Because of this, and because wildfires are not common in facility-specific hazard analysis documents, site-wide wildfires escaped consideration in the Draft SWEIS. At the same time, there was a general recognition of the threat to LANL, as evidenced

by the multiple agency cooperation in an ongoing fuel reduction effort. This oversight was brought to the DOE's attention during the public hearings on the Draft SWEIS, and an analysis was immediately begun with input from the Española District of the Santa Fe National Forest, the Bandelier National Monument of the National Park Service, the Los Alamos Fire Department, and LANL departments and personnel. The final analysis appears as SITE–04.

G.3.5 Worker Accident Screening

Analysis of worker accidents was performed to provide estimates of potential health effects from chemical and radiological exposure for involved workers. (For purposes of this SWEIS, workers within the TA where the accident occurs are defined as “involved workers,” and other on-site LANL employees are defined as “noninvolved workers.”) Because worker health risk from industrial accidents (falls, electrical shock, crushing, etc.) dominates over worker health risk from exposure from radiological and chemical accidents, worker accident analysis is not as extensive or detailed as that for public impacts. Also, there are far more low energy events whose impacts are highly dependent upon worker location and the details of the accident.

Worker accidents were reviewed qualitatively in order to arrive at a list of accidents that is representative of the accident potential at LANL under the four alternatives. The process used was similar to the analysis of accidents with public impact. The purpose of the separate worker accident screening was to identify whether there are accident scenarios that could have greater consequence to workers than the worker consequence associated with the public accident scenarios.

Data to support the accident analysis were obtained from a variety of sources, both facility- and site-specific as well as from industrial and

TABLE G.3.4.3-1.—Consolidated List of Accidents Subjected to Radiological Consequence

MATERIAL TYPE	HAZARD TYPE (PROCESS, MAN-MADE, NATURAL PHENOMENA)	FACILITY AND SCENARIO DESCRIPTION	ANNUAL FREQUENCY BIN
Highly Enriched Uranium, Depleted Uranium, Plutonium, Tritium, TRU	Natural Phenomena	Multiple facilities, site-wide earthquake resulting in structural damage or collapse	10^{-6} to 10^{-4}
Highly Enriched Uranium	Process	TA-3-29, fire/explosion in ULISSES solvent extraction line or HEU foundry	10^{-4} to 10^{-2}
	Process	TA-3-29, inadvertent criticality event due to multiple procedural violations and/or equipment failures	
	Man-Made	TA-3-29, aircraft crash and fire	10^{-6} to 10^{-4}
	Process	TA-18-116, power excursion leading to fuel melting	10^{-6} to 10^{-4}
	Process	TA-3-66, foundry fire	10^{-4} to 10^{-2}
Plutonium	Man-Made	TA-3-29, natural gas pipeline failure, ingestion of gas into building, explosion and fire	10^{-6} to 10^{-4}
	Process	TA-18-116, reactivity excursion, melting of Pu sample	10^{-6} to 10^{-4}
	Man-Made	TA-50-1, nonprocess-related boiler explosion, damage to clariflocculator	10^{-2} to 10^{-1}
	Process	TA-55-4, inadvertent criticality event due to multiple procedural violations and/or equipment failures	10^{-6} to 10^{-4}
	Process	TA-55-4, ion exchange column exothermic reaction and explosion, failure of HEPA filters	10^{-6} to 10^{-4}
	Process	TA-55-4, explosion and fire in hydride-dehydride glovebox, failure of HEPA filters	10^{-6} to 10^{-4}
	Process	TA-55-4, human error resulting in dropped plutonium oxide powder container, failure of HEPA filters	10^{-4} to 10^{-2}
	Process	TA-55-4, fire in heat source plutonium glovebox, fire suppression inoperable, HEPA filtration ineffective	10^{-6} to 10^{-4}
	Process	DARHT, inadvertent detonation	$< 10^{-6}$
	Process	DARHT, loss of containment	10^{-7} to 10^{-6}

TABLE G.3.4.3-1.—Consolidated List of Accidents Subjected to Radiological Consequence-Continued

MATERIAL TYPE	HAZARD TYPE (PROCESS, MAN-MADE, NATURAL PHENOMENA)	FACILITY AND SCENARIO DESCRIPTION	ANNUAL FREQUENCY BIN
Depleted Uranium	Process	TA-3-66, foundry fire	10^{-4} to 10^{-2}
Tritium	Process	TA-16-205, inadvertent opening of LP-50 container	10^{-2} to 10^{-1}
	Process	TA-16-205, high pressure gas handling system failure, ventilation isolation failure	10^{-4} to 10^{-2}
	Process	TA-16-205, tritium waste treatment system failure, ventilation isolation failure	10^{-4} to 10^{-2}
	Process	TA-21-155, release of tritium from nonsecondary contained system during maintenance, or release of tritium from glovebox due to leaking component	10^{-2} to 10^{-1}
	Process	TA-21-155, distillation column failure, vacuum jacket failure, fire	10^{-6} to 10^{-4}
	Process	TA-21-155, tritium leak, tritium waste treatment system failure	10^{-4} to 10^{-2}
	Man-Made	TA-21-155, aircraft crash and fire	10^{-6} to 10^{-4}
	Process	TA-21-209, molecular sieve regeneration error	10^{-4} to 10^{-2}
	Man-Made	TA-21-209, aircraft crash and fire	10^{-4} to 10^{-2}
	Man-Made	TA-54-1027, TA-54-1028, TA-54-1029, and TA-54-1041, unsuppressed wild fire, aircraft crash and fire, or truck fuel system leak and fire at tritium waste storage sheds	10^{-6} to 10^{-4}
	Process	TA-55-4, special recovery line de-inerting and fire	10^{-6} to 10^{-4}
TRU Waste	Man-Made	TA-50-37, aircraft crash and fire	10^{-4} to 10^{-2}
	Process	TA-50-69, TRU waste drum puncture by forklift outdoors	10^{-4} to 10^{-2}
	Man-Made	TA-50-69, truck fuel system leak and fire at outdoor container storage area	10^{-4} to 10^{-2}
	Man-Made	TA-54-38, truck fuel system leak and fire at outdoor container storage area	10^{-4} to 10^{-2}
	Man-Made	TA-54-229, TA-54-230, TA-54-231, and TA-54-232, aircraft crash and fire or unsuppressed wild fire at TWISP storage domes	10^{-6} to 10^{-4}

nuclear generic databases and compilations. Data sources included the following:

- Safety and hazard analysis documentation
- Data forms generated during the facility walkdowns
- LANL SWEIS alternatives documentation: generic data from industry and nuclear facilities including the following:
 - *Component Failure Rate Data with Potential Applicability to a Nuclear Fuel Plant* (Dexter and Perkins 1982)
 - *General Component Failure Data Base for Light Water and Liquid Sodium Reactor PRAs* (Eide et al. 1990)
 - *Handbook of Human Reliability Analysis with Emphasis on Nuclear Power Plant Application* (Swain and Guttman 1983)
 - *Natural Phenomena Hazards Modeling Project: Seismic Hazard Models for Department of Energy Sites* (Coats and Murray 1984)
 - Office of Nuclear and Facility Safety, Office of Environment, Safety and Health, U.S. Department of Energy, Washington, DC. Maintains and compiles a series of databases and reports on worker accidents in DOE facilities, including: (1) Occurrence Reporting and Processing System (ORPS) reports for LANL and other DOE facilities; (2) Office of Operating Experience Analysis and Feedback, Safety Notices; and (3) Office of Operating Experience Analysis and Feedback, Operating Experience Weekly Summary
 - Occupational Safety and Health Administration Form 200 Injury/Illness Reports for LANL and other DOE facilities

The summary listing identified more than 600 potential worker accident scenarios. Potential worker accident scenarios were then sorted by

material hazard and initiators and ranked according to relative risk. Risk was qualitatively assigned on the basis of the frequency and consequence ranking matrix for hazard evaluation described in DOE Standard 3009-94 (DOE 1994a) and shown in Figure G.1.1-1. The array of worker accidents was not dissimilar from the array of accidents with public impact, so that the worker accident component of the selected public accidents also provides a representative picture of the worker accident potential.

There are, however, some accidents that pose risk to workers but not to the public. An example is the medical research at TA-43-1, field work on small mammal capture and blood sampling, where the exposures to workers are localized and the exposure to the population from a release would be mitigated by environmental attenuation. Another exception is energetic hazards, where potential hazardous sources do not involve the public. Examples of energetic hazards are:

- High explosives
- Laser
- Pressurized gas
- Radiofrequency
- Liquid nitrogen/cryogen
- Neutron generator
- High pressure
- Hydrogen

Representative energetic hazard accidents include:

- Low pressure steam line failures (TA-16-205)
- Failure of cryogenic systems (TA-3-170, liquid nitrogen and liquid argon; TA-3-1698, liquid nitrogen; TA-16-205, liquid nitrogen; and TA-21-155, liquid nitrogen)
- Rupture of nontoxic gas bottles (TA-15-184, TA-50-1, TA-50-69, TA-54-39, and TA-59-1)

- Failure of noncombustible gas tube trailer (TA-3-29 and TA-50-69)
- Failure of pressurized gas lines (TA-16-205, TA-16-411)
- Electrical shock (all facilities)
- Laser accidents (TA-3-1698)
- Electromagnetic fields (TA-15-312 and TA-53)
- High explosive detonation (TA-15-184, TA-15-312, TA-16-260, TA-16-340, and TA-16-411)

The ranked worker accident scenarios were then compared to the public impact accidents with

comparable risk rankings. From the review of the chemical and radiological accidents selected for detailed quantification of public risk, as well as a screen of these accidents against the worker accidents, the following worker accidents were selected for more detailed evaluation:

- Inadvertent high explosives detonation
- Biohazard contamination of a single worker
- Inadvertent criticality event
- Inadvertent exposure to electromagnetic radiation (x-rays, accelerator beam, laser, or RF source)

G.4 EVALUATION OF RISK-DOMINANT ACCIDENTS

The risk-dominant accidents that were selected for detailed evaluation and impact quantification are shown in Table G.4–1. These are five site-wide accidents (earthquakes of varying severity and a wildfire), six chemical accidents, sixteen radiological accidents, and four worker hazard accidents.

G.4.1 Accident Frequency Assessment

This section contains the methodology used to determine the frequency of the different accident scenarios. The resulting frequencies, summarized in Table G.4.1–1, cover a wide frequency range. To place these frequencies in perspective, Table G.1.5–1 (section G.1 of this chapter) gives the probability of some natural phenomena at LANL and the probability of large meteors impacting somewhere in the world.

G.4.1.1 Earthquake Frequencies

The frequency of accidents arising from earthquakes is predicated upon a methodology set forth in DOE Standard 1020-94, *Natural Phenomena Hazards Design and Evaluation Criteria for Department of Energy Facilities* (DOE 1994e). Conceptually, the earthquake accident frequency assessment considers two parameters: (1) the frequency per year that earthquakes of different ground acceleration levels occur and (2) the conditional probability of component or structural failure, given those ground accelerations.

In practice, facilities are designed for earthquakes according to their hazard potential. The design for general industry is based on the Uniform Building Code (UBC), which has evolved considerably over the period of time during which currently active facilities at LANL

have been constructed (early 1950's through the 1990's). DOE nuclear facilities have design basis earthquake standards (depending upon the hazard potential of the facility) and performance requirements for avoiding hazardous material releases.

The treatment of earthquakes in facility safety documentation varies from the simple (screening earthquakes based on meeting the design basis earthquake guidance) to the bounding (assuming complete structural collapse) to the detailed (seismic margin analysis). In order to try to place the assessment of system and structural response for all LANL facilities on a consistent basis, estimates were made of a parameter known as the high confidence in low probability of failure (HCLPF). This is the ground acceleration level at which the analyst is very confident that the probability of failure is very low. The HCLPF value can be mathematically related to the seismic hazard (annual frequency of ground acceleration) to produce a point estimate of frequency at which system or structural failure will occur.

The seismic hazard at LANL was the subject of a state-of-the-art probabilistic seismic hazard analysis (PSHA) prepared for the laboratory and DOE by Woodward-Clyde Federal Services. The methodology used in the study is similar to (but more advanced in some areas) that approved by the U.S. Nuclear Regulatory Commission (NRC) for commercial nuclear power plant sites located east of the Rocky Mountains. The PSHA produces a variety of results expressing the annual frequency of ground motion at the LANL site. Among the more important results and implications of the LANL PSHA are the following:

- Many important facilities at LANL were designed and constructed in the 1950's through the late 1970's and do not compare favorably with current DOE seismic design requirements.

TABLE G.4-1.—Risk-Dominant Accidents at LANL

PROCESS HAZARD ACCIDENTS	
CHEM-01	Single cylinder release of chlorine (150 pounds) from a potable water chlorinator (TA-00-1109, bounding) due to equipment failure or human error during chlorine cylinder replacement or maintenance activities
CHEM-03	Single cylinder release of chlorine (150 pounds) from toxic gas cylinder storage facility (TA-3-476) due to human error during cylinder handling or cylinder deterioration due to unintended long-term exposure to weather
CHEM-06	Chlorine gas release (150 pounds) from a process line at the Plutonium Facility (TA-55-4) due to mechanical damage to a supply manifold
RAD-03	Reactivity excursion accident at Pajarito Site Kiva #3 (TA-18-116) with Godiva-IV outside the kiva, vaporizing part of the highly enriched uranium fuel and melting the remainder
RAD-04	Inadvertent detonation of a plutonium-containing assembly at or near the DARHT Facility firing point, resulting in an elevated, explosive-driven release of plutonium (TA-15)
RAD-09	Transuranic waste drum failure or puncture at TA-54, Area G (bounding)
RAD-10	Plutonium release from a degraded storage container in the Plutonium Facility (TA-55-4) vault during container retrieval (Note: Determined by detailed analysis to be a worker accident only.)
RAD-11	Container breach after detonation of a plutonium-containing assembly at the DARHT firing point (TA-15), resulting in a ground-level release of plutonium
RAD-13	Plutonium melting and release accident at Pajarito Site Kiva #3 (TA-18-116)
RAD-14	Plutonium release from ion exchange column thermal excursion at TA-55-4 (Note: Determined by detailed analysis to be a worker accident only.)
RAD-15	Plutonium release from hydride-dehydride glovebox fire at TA-55-4 (Note: Determined by detailed analysis to be a worker accident only.)
WORK-01	Worker fatality due to inadvertent high explosive detonation
WORK-02	Worker illness or fatality due to inadvertent biohazard contamination
WORK-03	Multiple worker fatality due to inadvertent nuclear criticality event
WORK-04	Worker injury or fatality due to inadvertent electromagnetic radiation exposure (x-ray, accelerator beam, laser, or RF source exposure)
MAN-MADE HAZARD ACCIDENTS	
CHEM-02	Multiple-cylinder chlorine release (1,500 pounds) due to explosion or unsuppressed fire affecting a toxic gas storage facility (TA-3-476)
CHEM-04	Single cylinder release of toxic gas (selenium hexafluoride, historical bounding chemical) from the legacy toxic gas storage facility (TA-54-216) due to random cylinder failure or a forklift accident
CHEM-05	Cylinder release of toxic gas (sulfur dioxide, historical bounding chemical) from the legacy toxic gas storage facility (TA-54-216) due to a fire, a propane tank boiling-liquid expanding vapor explosion (BLEVE), or a propagating random failure
RAD-01	Plutonium release due to container storage area fire involving transuranic waste drums (TA-54-38)
RAD-02	Plutonium release due to natural gas pipeline failure near TA-3-29, with no immediate ignition, ingestion of gas into facility, followed by explosion and fire
RAD-05	Aircraft crash with explosion and/or fire at TA-21 resulting in a tritium oxide release

TABLE G.4-1.—Risk-Dominant Accidents at LANL-Continued

RAD-06	Aircraft crash with explosion and/or fire at TA-50-37, resulting in a plutonium release from transuranic waste drums (Note: Retained based on preliminary calculations; final calculations determined that this accident screened on frequency less than 1×10^{-7} per year.)
RAD-07	Plutonium release due to container storage area fire involving transuranic waste drums (TA-50-9)
RAD-08	Aircraft crash with explosion and/or fire at the transuranic waste dome area at TA-54 (TA-54-229, TA-54-230, TA-54-231, and TA-54-232)
RAD-16	Aircraft crash with explosion and/or fire at TA-3-29 resulting in a plutonium release
NATURAL PHENOMENA HAZARD ACCIDENTS	
SITE-01	Site-wide earthquake, resulting in damage to low capacity structure or internal components at multiple facilities
SITE-02	Site-wide earthquake, resulting in damage to moderate capacity structures or internal components at multiple facilities
SITE-03	Site-wide earthquake, resulting in structural damage or collapse to all facilities
SITE-03, Surface Rupture	Site-wide earthquake with accompanying surface rupture on subsidiary faults, resulting in structural damage or collapse to all facilities
SITE-04	Site-wide wildfire, consuming combustible structures and vegetation.
RAD-12	Plutonium release from a seismically initiated event

TABLE G.4.1-1.—Accident Annual Frequency Results, by Alternative

ACCIDENT SCENARIO	NO ACTION	EXPANDED OPERATIONS	REDUCED OPERATIONS	GREENER
SITE-01	2.9×10^{-3}	same	same	same
SITE-02	4.4×10^{-4}	same	same	same
SITE-03	7.1×10^{-5}	same	same	same
SITE-03, Surface Rupture	1 to 3×10^{-5}	same	same	same
SITE-04	0.1	same	same	same
CHEM-01	1.2×10^{-3}	1.3×10^{-3}	1.1×10^{-3}	1.2×10^{-3}
CHEM-02	1.3×10^{-4}	1.5×10^{-4}	1.2×10^{-4}	1.3×10^{-4}
CHEM-03	1.2×10^{-4}	same	same	same
CHEM-04	4.1×10^{-3}	same	same	same
CHEM-05	5.1×10^{-4}	same	same	same
CHEM-06	6.3×10^{-2}	same	same	same
RAD-01	1.6×10^{-3}	same	same	same
RAD-02	$< 10^{-6}$ (Incredible)	same	same	same
RAD-03	3.4×10^{-6}	4.3×10^{-6}	3.4×10^{-6}	3.4×10^{-6}
RAD-04	$< 10^{-6}$ (Incredible)	same	same	same
RAD-05	3.8×10^{-6} (TSTA) 5.3×10^{-6} (TSFF)	same	same	same
RAD-06	$< 10^{-6}$ (Incredible)	same	same	same
RAD-07	1.5×10^{-4}	3.0×10^{-4}	1.1×10^{-4}	1.5×10^{-4}
RAD-08	4.3×10^{-6}	same	same	same
RAD-09	4.1×10^{-3} 0.4	4.9×10^{-3} 0.49	3.9×10^{-3} 0.38	4.1×10^{-3} 0.4
RAD-10	$< 10^{-6}$ (Incredible)	same	same	same
RAD-11	$< 10^{-6}$ (Incredible)	same	same	same
RAD-12	1.5×10^{-6}	same	same	same
RAD-13	1.6×10^{-5}	same	same	same
RAD-14	$< 10^{-6}$ (Incredible)	same	same	same
RAD-15	3.2×10^{-5}	same	same	same
RAD-16	3.5×10^{-6}	same	same	same
WORK-01	0.001 to 0.01	same	same	same
WORK-02	0.01 to 0.1	same	same	same

TABLE G.4.1-1.—Accident Annual Frequency Results, by Alternative-Continued

ACCIDENT SCENARIO	NO ACTION	EXPANDED OPERATIONS	REDUCED OPERATIONS	GREENER
WORK-03	$< 1.0 \times 10^{-5}$	same	same	same
WORK-04	0.01 to 0.1	same	same	same
WORK-05	0.23	same	same	same

- Earthquakes simultaneously affect all LANL facilities.
- All risk-significant facilities at LANL are located within 3.5 miles (5.6 kilometers) of the Pajarito Fault, which runs parallel to the western boundary of LANL and slopes down-to-the-east under the laboratory. The Pajarito Fault, along with the Embudo Fault (which runs to the north of LANL), is the principal source of large ground motions at LANL.
- The PSHA indicates that, for all eight LANL locations for which detailed calculations were performed, the frequency of a 1.0 g (where “g” is the acceleration due the Earth’s gravity) peak horizontal ground acceleration is approximately 1×10^{-5} years (about once in one hundred thousand years), which is both well within the bounds of what is considered to be “credible” under NEPA (DOE 1993a) and large enough to heavily damage essentially all LANL facilities.

In order to evaluate earthquake damage to LANL facilities, HCLPF values were estimated based on a variety of sources of information, including detailed seismic margin studies¹ (e.g., TA-3-29 and TA-55-4) and safety documentation. Where no detailed information was available, HCLPF values were based on expert judgment and facility walkdowns. The HCLPF values were mathematically related to the PSHA results such that the HCLPF value is directly related to an annual frequency of occurrence. When this was done, the frequencies of failure of the facilities fell into three groupings for which the frequencies of occurrence differ by only a factor of 3 to 4 within the group. Considering the approximate method used to generate the results, this is considered to represent appropriate groupings for accident analysis purposes. The three

¹. A Seismic Margin Study is a study undertaken to quantify the ability of a structure, system, or component to withstand an earthquake greater than it was designed for and still achieve its function.

earthquake scenarios, and their corresponding frequencies, are as follows:

- SITE-01, HCLPFs ranging from 0.04 g to 0.10 g, with a frequency of 3×10^{-3} per year, corresponding to failures of components and structures with relatively low seismic capacities.
- SITE-02, HCLPFs ranging from 0.10 g to 0.25 g, with a frequency of 4×10^{-4} per year, corresponding to failures of components and structures with moderate seismic capacities.
- SITE-03, HCLPFs ranging from 0.25 g to 0.44 g, with a frequency of 7×10^{-5} per year, corresponding to failure of components and structures with comparatively high seismic capacities.

Seismic studies recently completed and currently in progress have further evaluated the potential for ground faulting. These studies indicate the possibility of such events is low, but credible, at some locations on the LANL site. In addition, the potential of ground faulting at one facility of concern, the CMR Building, will be discussed as a subsection of the SITE-03 event. Section 4.2.2.2 (in volume I, chapter 4) and appendix I discuss further the recently completed studies and their implication for LANL and DOE.

In practice, with significant analytical resources assigned, it would be possible to derive robust HCLPF values and then convolve that information with the seismic hazard curve to identify failure frequencies for all important LANL facilities. However, even were this done, the uncertainties in the results would be substantial due to the uncertainty in the seismic hazard. For example, the range in ground acceleration from the 5th to the 95th percentile, result at a frequency of 1×10^{-5} per year, is from 0.55 g to more than 1.0 g. The representation of the earthquake risks by using the three site accidents identified above provides a reasonable level of resolution for the purposes of NEPA accident analysis.

G.4.1.2 *Fire and Other Accident Frequencies and 1969 Rocky Flats Fire*

Accident frequency assessments were performed for accidents other than those caused by earthquakes and aircraft crash using PRA-based methods and available LANL and industry data sources. The accidents were examined in a step-by-step method that carefully examined the sequential progression of the accidents, beginning with an initiating event and continuing through the chain of equipment failures, human actions, and phenomenological events that constitute the accident scenario. General guidance for such calculations is provided in a Sandia National Laboratories (SNL) publication (Mahn et al. 1995), and this general guidance has been supplemented by numerous LANL-specific and other studies in order to provide a defensible basis for the accident frequency analysis.

It should be recognized that the DOE safety analysis guidance does not require PRA calculations to be performed in order to categorize the likelihood of accident scenarios (DOE 1994a). Rather, coarse binning efforts are undertaken to qualitatively rank the accident scenarios into frequency bins for the purposes of hazards analysis.

Fire other than from earthquake and aircraft crash was postulated to release MAR in several of the analyses (e.g., RAD-01 and RAD-07). A truck fire was considered more likely than other fire initiators (such as wildfire, lightning, and forklift fires) in outdoor areas and was used. However, a leaking fuel system on a truck that goes unnoticed long enough to pool a large amount of fuel, then followed with an ignition capable of igniting the nonvolatile diesel fuel, has a low frequency that is difficult to quantify. The same is true for wildfire in paved areas and for fires initiated by lightning. However, these accidents were retained for analysis because the combined frequency of fires from all causes is

thought to pose a credible accident. (The explosive potential of diesel fuel tanks on trucks and other vehicles is very small and was screened out by more likely accident initiators at facilities where trucks might visit.)

In the Final Programmatic Environmental Impact Statement for Stockpile Stewardship and Management (SSM PEIS) (DOE 1996f) the reassignment of pit manufacturing to LANL was analyzed. In the resulting Record of Decision (ROD) (61 CFR 68014), DOE discussed the decision made, that is, to move pit manufacturing to LANL. Historically, pit manufacturing was conducted at the Rocky Flats Plant (now known as the Rocky Flats Environmental Technology Site [RFETS]). At RFETS, a major fire occurred in 1969, and minor fires occurred on other occasions in similar accidents. Plutonium was released in the 1969 fire-related accident.

To provide a better idea of the differences between the operations at Rocky Flats in 1969 and the operations in TA-55 today, a description of the 1969 Rocky Flats fire, as provided by the Atomic Energy Commission (AEC) at the time of the fire, is provided below (AEC 1969). This description includes the findings presented by the AEC. These findings have since been used to improve design characteristics and operating procedures in all DOE nuclear facilities. Thus, a similar sequence of events would not be possible either because of built in barriers that would restrict the initiation of such an event or would prevent the propagation of such a fire.

The LANL Plutonium processing facility, TA-55-4, was designed to correct the deficiencies that led to the 1969 Rocky Flats fire. In the following discussion, the AEC findings are crosswalked to design features and operating procedures that exist in TA-55 today. As demonstrated in this crosswalk, if the preventative measures that exist in TA-55 today were present at Rocky Flats in 1969, the major

fire that resulted in release of plutonium would not have happened.

Fire is always a concern when working with any pyrophoric material such as plutonium. However, TA-55 was designed with specific engineering features to prevent fire and is where plutonium has been worked with, handled, and stored for many years. Its past and current research and development missions have been specifically focused on understanding plutonium and its material properties. Introducing pit production at Los Alamos, therefore, does not dramatically increase the potential for fire because TA-55-4 is where plutonium has been stored, handled, and processed since the facility's original inception.

In fact, the fire at Rocky Flats began in a process development area not a production area. The major differences in TA-55-4 that prevent a building-wide fire are specific operating procedures and design features (barriers) that were established based on lessons learned from fires such as that which happened at Rocky Flats. These barriers prevent the fire from starting, as well as prevent its spread should a fire start. As presented in the following discussion, the inference that TA-55-4 will have a building wide fire now that the facility is producing pits is misleading.

Description of the 1969 Fire at the Rocky Flats Plant

The available evidence indicates that the fire originated on the lower shelf of the storage cabinet in Glovebox 134-24 (see Figure G.4.1.2-1) in the North Line. Plutonium briquettes (discs 3 inches [8 centimeters] in diameter and 1 inch [3 centimeters] thick of either pressed scrap metal or lathe turnings) and some loose scrap metal were stored in uncovered cans in the storage cabinet. The exact cause of ignition is unknown; however, plutonium in the form of chips or lathe turnings is pyrophoric and caught fire. The heat from the burning plutonium metal evidently caused the

storage cabinet, which was constructed mostly of cellulosic laminate material and plastic, to char and generate flammable gases that may have been ignited by burning plutonium. The heat of the burning gases may have ignited other briquettes and initiated a slow burning of the storage cabinet materials, particularly in the cracks between the joined sections of the cellulosic materials. Regardless of the process, the fire spread to the outer surfaces of the cabinet.

The smoke in the exhaust system of the North Line gradually clogged the filters. The flames on the outer surfaces of the cabinet spread to the combustible gloves and plastic windows on Glovebox 134-24. Up to this time, the fire was still undetected by the few people who were in the building that day because the smoke, flames, and heat were contained within the glovebox system. Because the heat detectors were located outside and under Glovebox 134-24 and were insulated by the floor of the storage cabinet, they were incapable of sensing the fire. (Similar detectors elsewhere in the glovebox system subsequently did function, and the alarm was sounded.)

Once the plastic windows of Glovebox 134-24 were breached, the air rushing in fanned the fire and caused it to spread into the North Conveyor Line and into the gloveboxes east of Glovebox 134-24.

The airflow in the North Conveyor Line normally flowed from east to west. However, because of the clogged filters, the airflow in the line reversed and followed the second ventilation system, which was part of the North-South Line and the Center Line. When the fire reached the North-South Line, it turned south because of two factors: a closed metal door in the North Line and the direction of the airflow. On reaching the Center Line, the fire again went east because of the airflow.

The first indication of a fire was an alarm received in the plant's fire station at 2:27 p.m.

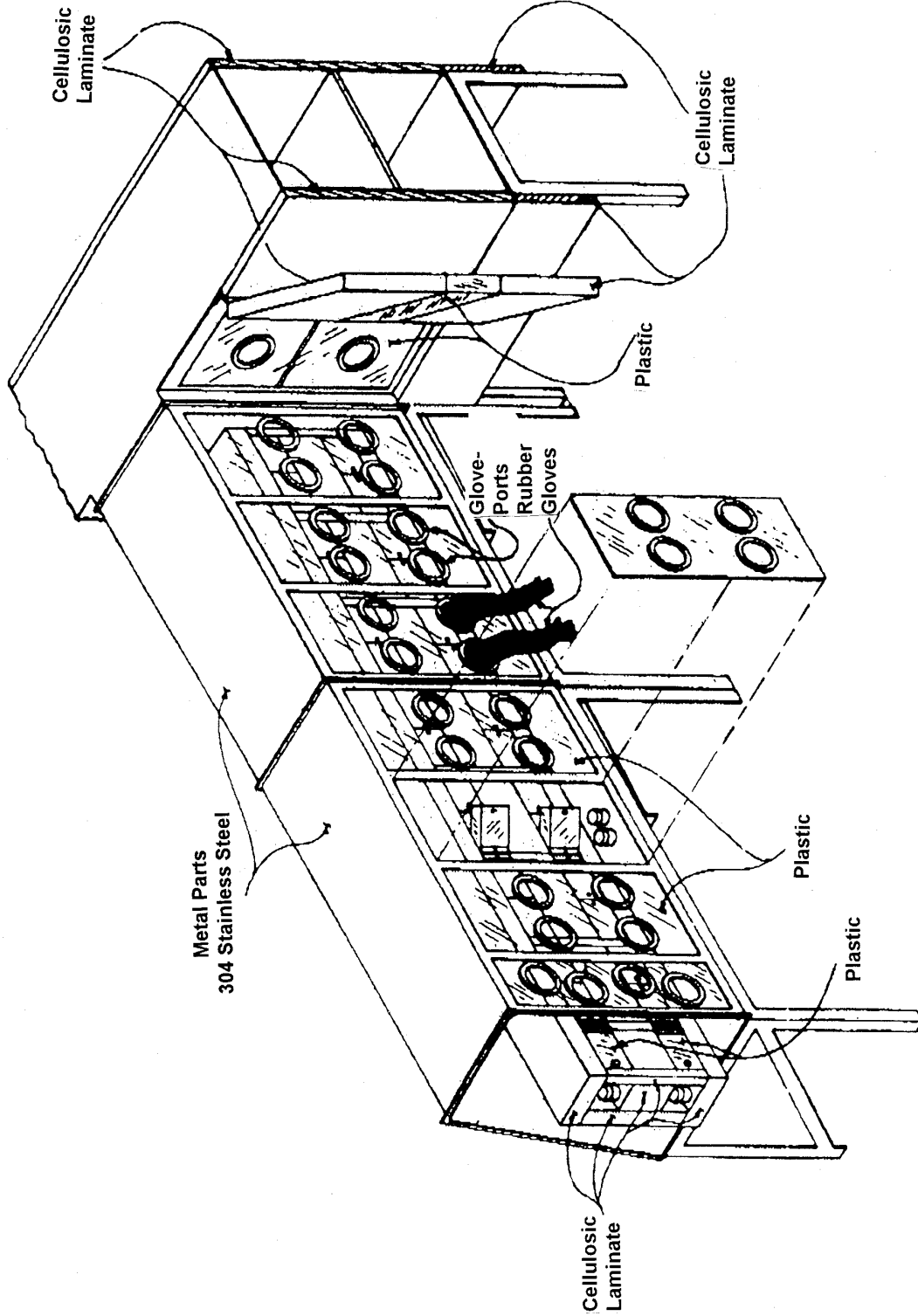

FIGURE G.4.1.2-1.—Rocky Flats Site, Glovebox I23-24

on May 11, 1969, from the heat-sensing system that monitored temperatures at various locations in the glovebox systems in Building 776-777. Although the fire department responded promptly, the dense smoke, crowded conditions, and presence of large quantities of combustible shielding material made the fire very difficult to fight and extinguish. Because of the concern about the possibility of a nuclear criticality accident (a chain reaction), the standard firefighting procedures then in effect for Building 776-777 did not specify the use of water, except as a last resort. For this reason, there was no automatic sprinkler system in this area of the building. The first attack on the fire was made with carbon dioxide and was ineffective. Less than 10 minutes after the fire alarm was received, the fire captain initiated the use of water. Thereafter, water was used almost exclusively in the firefighting activities. No nuclear criticality occurred. The fire was brought under control about 6:40 p.m., but continued to burn or recur in isolated areas throughout the night.

The damage to Building 776-777 and its equipment was extensive. In addition to the actual fire and smoke damage, the building was heavily contaminated internally with plutonium. Substantial parts of the utility systems within the building were severely damaged. Some of the interconnected buildings sustained minor interior contamination. The fire did not breach the building roof, but slight exterior contamination was measured on the roof of Building 776 and an adjoining building, apparently due to a minor failure of a filter. Instrument readings indicated a level of 0.02 microcuries per 100 square centimeters with a few spots up to 0.2 microcuries per 100 square centimeters. Plutonium also was tracked out of Building 776 by the firefighters and was detectable on the ground around the building. Survey instrument readings in these areas indicated from 0.02 to 0.2 microcuries per 100 square centimeters.

AEC Findings on the May 1969 Rocky Flats Plant Fire

The AEC Report presented the following findings from the May 1969 fire at the Rocky Flats Plant (AEC 1969).

- With the available evidence, the AEC has no basis for concluding that the fire was set intentionally.
- The plastic windows contributed heavily to the spread of the fire and the extent of the loss. These windows, a major structural part of the containment system, provided a fuel surface on the inside of the glovebox-conveyor systems. Continued operation of the glovebox ventilation systems provided a supply of air to support the combustion. Under these conditions, burning of the windows and plutonium would have resulted essentially in the same loss as was experienced even if no other combustible materials had been present.
- Less than 1 percent of the total of almost 600 tons of combustible radiation shielding was consumed in the fire.
- The long interconnected conveyor system without physical barriers provided a path for the fire to spread. The closed metal door in the North Line demonstrated the effectiveness of even a simple firebreak in the line.
- The storage of plutonium briquettes in cans without lids provided potential ignition sources.
- Without the plastic and cellulosic laminate cabinet in Glovebox 134-24, it is unlikely that a plutonium briquette burning in an open metal container would have ignited the plastic windows.
- The addition of the storage cabinet, which nullified the heat-sensing system in Glovebox 134-24, prevented an earlier warning of fire.

Crosswalk of Design Barriers and Operating Procedures Between Rocky Flats in 1969 and TA-55-4 in 1998

The Rocky Flats fire started from the burning of plutonium metal scraps that were stored in metal containers without lids. In TA-55, plutonium is stabilized prior to storage. In this case, storage of scrap material is not permitted in open containers.

The storage containers at Rocky Flats were placed in storage cabinets that were made out of plastic and cellulosic laminate material, providing a fuel source for the burning plutonium. At TA-55, these types of storage cabinets are not used. Studies on combustible loadings are required for all operations that will be conducted within the gloveboxes, and restrictions are placed on the quantities of combustible materials to ensure that fires cannot be sustained and then propagated. Good housekeeping as well as other control measures such as conducting machining operations without oil has led to a drastic reduction in incipient fires.

Once the fire at Rocky Flats was started, the fire detection systems did not sense the fire because the detectors were located on the outside of the gloveboxes, and the fire in its early stages was confined to the inside of the gloveboxes. Additionally, the glovebox acted to insulate the sensor from the heat of the fire—in effect preventing an early warning. In TA-55-4, the gloveboxes, have sensors both on the inside as well as on the outside of the gloveboxes, and additional sensors exist within the rooms. If the processes within the gloveboxes are modified, it is required to check the sensors to ensure that they have not been blocked.

Once the storage cabinets at Rocky Flats were set on fire, the fire propagated to the plastic gloves and plastic window on the glovebox, burned through, and created a breach in containment. Without the charring of the cabinets and the production of combustible

gases, the fire would probably not have spread to the glovebox; however, in this case, the fire was sustained to the point that it could propagate to the glovebox. At TA-55-4 the gloveboxes themselves are required to provide a fire barrier between material in the glovebox and the room itself.

Once the fire at Rocky Flats breached the gloveboxes, there was radiation shielding that surrounded the gloveboxes and the conveyor lines. This material also was combustible, and a small percentage of it burned in the Rocky Flats fire. At TA-55-4 combustible loading within the separate laboratories is kept to a minimum. Also, due to the integration of safety management functions, the solution to one safety concern (such as the use of radiation shielding) is looked at for the potential to cause other safety concerns (such as the propagation of fires). Thus, radiation shielding used at TA-55-4 is not typically flammable.

At Rocky Flats there were no automatic sprinklers in this area of the building due to concerns about a criticality accident. At the time of the fire, the standard firefighting procedure was not to use water, except as a last resort. Within 10 minutes of the fire alarm, the firefighters used water and no criticality occurred. Automatic sprinkler systems are available in TA-55 to stop the spread of fires. In addition, fire water traps, that contain neutron absorbing material, are available to ensure that a criticality event does not occur.

The fire at Rocky Flats propagated east along the conveyor line, turning south following the airflow of the second ventilation system. Continuation of the fire through the North Line conveyor was stopped because of a closed metal door and the prevalent airflow conditions. The glovebox lines in TA-55-4 have automatic dampers that close in the event of a fire. These dampers are at the junction with each trunk line and between rooms. Also, the ventilation system is shutdown in the event of a fire to prevent airflow.

The degree of contamination in the buildings at Rocky Flats was due to regularly spaced plutonium material in the conveyor system and in the gloveboxes. Pit production at TA-55-4 will not come close to the capacity that was required at Rocky Flats. Thus, the amount of plutonium in the gloveboxes will be considerably less than was present at Rocky Flats. The processing lines will be configured in such a manner that a continuous source of exposed plutonium will not be present. Plutonium stored in the gloveboxes also must be in closed containers.

Additionally, Building 776-777 at Rocky Flats did not have an operations center that was staffed 24 hours a day providing full-time monitoring of systems. TA-55-4 has a fully staffed operations center to provide monitoring of systems and alarms on a 24-hours per day basis.

Summary of Differences Between Rocky Flats and TA-55-4

Substantial differences exist between the nuclear facility and operations being conducted in TA-55-4 today and those that were present at Rocky Flats in 1969. The above crosswalk illustrates the barriers that are in place at TA-55-4 that would have prevented the building wide fire at Rocky Flats. TA-55-4 was designed to correct the deficiencies detected in older facilities such as RFETS and is being upgraded to meet the even more stringent requirements of the 1990's, including enhanced seismic resistance and fire containment. Alarms are monitored, and the Operations Center is manned continually at TA-55. The amount of plutonium required for production at LANL is about half that required during RFETS operations. The manufacturing operations are substantively different than those at RFETS, significantly reducing risk. The concern that building wide fires will occur at TA-55-4 due to pit production operations being located at this facility is not plausible considering the controls that exist today.

Consideration of Fires at TA-55-4 in the SWEIS

The SWEIS, however, does consider the potential for fire in TA-55-4. A glovebox fire is analyzed in RAD-14, section G.5.6.14. A glovebox fire is considered credible; but the release of material to the public is not a credible event. A building-wide fire was screened based on the very low probability of propagating a glovebox fire to a laboratory, a laboratory fire to a wing, and a wing fire to the entire building. With the enhancement of pit production, the characterization of accidents at TA-55-4 and, therefore, the risk in operating the site does not change.

G.4.1.3 Aircraft Crash Frequencies

This section of the accident appendix presents an analysis of the frequency of an aircraft crash into structures located within the various TAs at LANL. In 1996, LANL issued a study performed by Selvage (LANL 1996c) that used the K. Solomon Model as a basis for aircraft crash frequency assessment. The LANL assessment has been overtaken by subsequent events.

In October 1996, DOE issued a final standard for *Accident Analysis for Aircraft Crash into Hazardous Facilities* that presents a standardized approach (DOE 1996c). The new standard was developed by an inter-agency working group with membership from DOE, the Defense Nuclear Agency, Westinghouse Savannah River Corporation, the Federal Aviation Administration (FAA), the EPA, and the NRC. The working group chairman and an expert panel (with technical experts from private industry, government, and the national laboratories) developed the standard. Technical support teams (data, modeling, structural, and exposure), which also included membership from private industry, government, and the national laboratories, provided technical input and data used in developing the standard. The

standard was issued with a number of supporting technical documents for use in safety analysis.

In November 1996, the Final EIS on continued operation of the Pantex Plant and storage of nuclear weapon components was issued by DOE (DOE 1996a). Appendix E of the Pantex EIS included an aircraft crash frequency analysis prepared using the July 1996 draft of DOE Standard 3014. The final version of the DOE aircraft crash standard methodology was applied to LANL facilities to estimate the frequency of an aircraft crash into those facilities (DOE 1996c). Current and projected data describing air traffic are used in the analysis; aircraft traffic rates for Los Alamos Airport traffic reflect projected traffic for the year 2003, which is considered to be a reasonable approximation to the traffic in 2006 (the end of the SWEIS analytical period). The projected air traffic includes air taxi service to Los Alamos Municipal Airport (LAM), although no such service currently exists. This traffic component was retained because air taxi service has existed in the recent past and there is no way of knowing whether it will resume during the SWEIS analytical period extending to 2006.

An estimate of the frequency of an aircraft crash into any of the facilities of interest was generated and is shown in Table G.4.1.3–1. Table G.4.1.3–2 presents the projected number of aircraft operations at LAM.

Site Analysis of Crash Risk

Because there are no alternative sites included in the SWEIS, LANL is the only site that is analyzed with respect to the risk due to aircraft crash. LANL is located within 1 mile (1.6 kilometers) of LAM at its closest point. LAM consists of one runway, which runs from east to west. The primary purpose of LAM is to support the missions of the DOE and LANL (Greiner 1994). Due to local conditions, all takeoffs are to the east, and all landings are to

the west. The west end of the runway is only used for runups and taxiing. There is prohibited airspace over LANL (Restricted Airspace R–5101) up to 14,000 feet (4,267 meters). The restricted airspace forces flights taking off from or landing at LAM to follow a path around LANL. During certain inclement weather flight conditions, LANL grants permission to overfly the Live Firing Range (TA–72). To perform this overflight, pilots must receive prior permission, and the firing range ceases operations during the overflight (LANL 1996c).

Note that the DOE standard (DOE 1996c) does not provide for a reduction in crash frequency to account for restricted airspace. Restricted airspace is an administrative control; no physical barriers exist. In the event of an aircraft accident, loss of control is presumed. Thus, the aircraft could, in principle, crash anywhere, including within a restricted airspace. Moreover, flights above 14,000 feet (4,267 meters) can overfly LANL in any event. Thus, while giving no credit to the restricted airspace in terms of reducing crash frequencies may be conservative, the degree of conservatism is not believed to be large enough to warrant a departure from the DOE Standard.

In addition to LAM, there are two airports in the vicinity of LANL. Santa Fe Municipal Airport is located approximately 18 miles (29 kilometers) southeast of LANL. Albuquerque International Airport is located approximately 56 miles (90 kilometers) southwest of LANL. These two airports are outside of the probability density function boundary for all categories of aircraft. Thus, only LAM airport activity and nonairport (in-flight) aircraft were included in the analysis as described in the DOE standard (DOE 1996c).

In this analysis, 1993 data obtained from the *Los Alamos Airport Master Plan* (Greiner 1994) indicate that there are approximately 12,431 operations per year at LAM. This number is split between Ross Aviation operations, permit

TABLE G.4.1.3-1.—Aircraft Crash Rates

AIRCRAFT CATEGORY	CRASH RATE	
	TAKEOFF (PER TAKEOFF)	LANDING (PER LANDING)
COMMERCIAL		
Air Carrier	1.9×10^{-7}	2.8×10^{-7}
Air Taxi	1.0×10^{-6}	2.3×10^{-6}
MILITARY		
Large ^a	5.7×10^{-7}	1.6×10^{-6}
Small ^b	1.8×10^{-6}	3.3×10^{-6}
GENERAL AVIATION		
Fixed-Wing, Single-Engine	1.1×10^{-5}	2.0×10^{-5}
Fixed-Wing, Multiple-Engine Piston	9.3×10^{-6}	2.3×10^{-5}
Fixed-Wing, Turboprop	3.5×10^{-6}	8.3×10^{-6}
Fixed-Wing, Turbojet	1.4×10^{-6}	4.7×10^{-6}

^a Large military aircraft include bomber, cargo, and tanker aircraft.

^b Small military aircraft include fighter, attack, and trainer aircraft.

Source: DOE 1996c

TABLE G.4.1.3-2.—Projected LAM Yearly Flight Operations (Year 2003)

AIRCRAFT CATEGORY	FLIGHT OPERATIONS	TAKEOFFS	LANDINGS
Air Carrier	0	0	0
Air Taxi	5,400	2,700	2,700
Large Military	0	0	0
Small Military	0	0	0
Single-Engine Piston	11,781	5,891	5,891
Multiple-Engine Piston	794	397	397
Turboprop	13	6	6
Turbojet	13	6	6
Total	18,000	9,000	9,000

Source: Greiner 1994

(based) aircraft operations, and transient aircraft operations.

The LAM Master Plan study forecasted future annual aircraft operations of 18,000 for the year 2003. This total includes 5,400 air taxi operations, 10,600 permit aircraft operations, and 2,000 transient aircraft operations. These projected numbers are used in the analysis, assuming half are takeoffs and half are landings.

According to the LAM Master Plan study, more than 99.9 percent of the aircraft forecasted to use LAM are Class A (12,500 pounds or less, single-engine) and B (12,500 pounds or less, multiple-engine) small aircraft. Less than 0.1 percent are Class C (12,500 to 300,000 pounds, multiple-engine), and no Class D (over 300,000 pounds, multiple-engine) aircraft can operate at LAM (Greiner 1994).

Based on the above percentages, the 13,800 general aviation operations were split between the four DOE standard (DOE 1996c) general aviation categories. The LAM Master Plan study indicates that the number of general aviation operations is dominated by “based” aircraft. Because based aircraft are predominately single-engine piston aircraft, the split between single-engine and multiple-engine aircraft was based on the percentage of based aircraft from these classes. Thus, 93.5 percent of the operations were assigned to single-engine aircraft, 6.3 percent to multiple-engine aircraft, and 0.1 percent each to turboprops and turbojets. One hundred percent of the air taxi operations were assumed to be accomplished using DHC-6 Twin Otter aircraft (Greiner 1994). This aircraft is considered an air taxi by the DOE standard technical support material (LLNL 1996). The actual wingspan of this aircraft is 65 feet (20 meters) (Jane’s 1995). This wingspan was used in the calculation.

Because LANL TAs are within the aircraft category dependent exclusion distance from LAM, the aircraft operations of interest for this analysis are takeoff, landing, and in-flight

modes. The length of the east-west runway at LAM is approximately 1.0 mile (1.61 kilometers). Due to the aircraft category dependent exclusion distance, all aircraft considered as in airport operation on the east-west runway were either in the takeoff or landing mode. For this runway, 50 percent of operations are takeoffs and 50 percent are landings. LANL resides within the aircraft category dependent exclusion distances, so a near-airport analysis was required, and probability density function values were used in this analysis.

The NPf (x,y) values provided in DOE Standard 3014-96 (DOE 1996c) for the various aircraft categories reflect the crashes per square mile, per year, centered at a given site for nonairport operations. In this analysis, the following NPf (x,y) values (in crashes per square mile per year, centered at the site) for LANL were used (DOE 1996c):

$$\text{NPf (x,y) General Aviation} = 2 \times 10^{-4}$$

$$\text{NPf (x,y) Air Carrier} = 2 \times 10^{-7}$$

$$\text{NPf (x,y) Air Taxi} = 3 \times 10^{-6}$$

$$\text{NPf (x,y) Large Military} = 1 \times 10^{-7}$$

$$\text{NPf (x,y) Small Military} = 5 \times 10^{-6}$$

These values are specific to the LANL site, and are based on an analysis of the locations of past aircraft crashes within the continental U.S. The data are substantial for general aviation aircraft (over 1,000 crashes), while the available data for other aircraft categories (air carrier, large military, etc.) are very limited. Crash location frequencies for general aviation aircraft were based on the assumption that future levels of activity and flight patterns will be similar to the historical record.

Nonairport commercial and military crash frequencies are based on the assumption that the aircraft will fly point-to-point under the new

FAA regulations, rather than in specific airways. The model for these aircraft assumes that the traffic density within an Air Route Traffic Control Center (ARTCC) is uniform, and that given a crash within the ARTCC, the location of the crash is random. The crash rate is assumed to be uniform for the continental U.S. and proportional to the aircraft traffic volume handled at each ARTCC.

For small military aircraft, however, the number of crashes per year is estimated for each ARTCC based on the distribution of crash locations in the historical record. It is important to recognize that the in-flight analysis for military aviation applies only to normal in-flight operations outside military operations areas and low-level flight ranges.

Frequency of Releases as a Result of Aircraft Crash

It was recognized early in this SWEIS analysis that seismic events can cause simultaneous releases of hazardous materials from multiple facilities at frequencies in the range of 1×10^{-5} per year and higher. Accordingly, detailed aircraft crash consequence calculations were only performed if it appeared that the frequency and source term of the aircraft crash accident were risk-significant compared with the seismic event; that is, the products of the consequence and frequency were comparable. In this analysis, facilities that contain plutonium, tritium, and hazardous chemicals were considered.

The DOE Standard 3014-96 (DOE 1996c) provides methodologies for: (1) estimating the frequency of aircraft impact into a facility, based on a conservative, simplified equation; (2) determining the effect of the impact on the facility through structural response analysis; (3) determining the frequency of a release of hazardous materials from the facility, given an aircraft impact; and (4) evaluating the exposure resulting from such a release.

The DOE Standard 3014-96 approach to aircraft crash analysis is intended for use in safety analysis. The methodology provides an approximate level of risk, rather than a detailed risk assessment. As a result, the methodology adopts typical accident analysis practice by addressing uncertainty through the use of analytical margin instead of a formal uncertainty analysis. The focus is on analyzing the risk posed to the health and safety of the public and on-site workers. The standard does not consider the risk to the occupants of the aircraft, the risk to individuals inside a building affected by a crash, nor the risk to other individuals on the ground (either inside or outside a facility boundary) who might be directly impacted by the crash (DOE 1996c). The methodology also does not consider malicious acts (e.g., sabotage, terrorism, and war) (DOE 1996c).

Estimating the frequency of hazardous material releases as a result of aircraft involves a series of calculations of increasing analytical sophistication, to the level required to demonstrate that aircraft crash either does or does not cause a level of risk equivalent to that from other risk sources. The analysis considers the structural properties of the affected facility as well as its inventory of hazardous materials.

Local impacts to facilities include penetration, perforation, and scabbing. Penetration occurs when the missile (flying debris) striking a facility intrudes into the outer surface of the structure. Perforation occurs when the missile punctures a hole all the way through the concrete or steel surface. Scabbing occurs when the missile does not perforate, but does cause concrete to be ejected from inside face of the target into the facility.

Because heavy, high-speed aircraft have much greater potential to damage than do slow, light aircraft, the method requires that the population of aircraft in the skies around the site be resolved into subpopulations by weight and speed. A structural calculation is performed to

determine if an aircraft that hits a facility will cause sufficient damage to warrant further analysis. Aircraft missiles (i.e., flying objects from the crash) for the structural calculations are selected by using representative engine weights and diameters. The structural analysis is performed by calculating the scabbing and perforation thickness for each aircraft category into the facility using an empirical model.

The first step in the process is to determine the representative type of aircraft for each category. Next, the effective area of a facility is determined based upon the length, width, and height of the facility and the aircraft's wingspan, flight path angle, heading relative to the heading of the facility, and the length of its skid. Using the calculated area of a facility, the number of operations near a facility, and crash rate density function, the frequency of hitting the facility for each aircraft category is calculated. The total frequency is the sum of all the aircraft category frequencies. If the total frequency of hitting a facility is greater than 1×10^{-6} , further analysis is conducted.

The calculations are refined to eliminate aircraft categories that cannot cause a release of hazardous materials, leaving only those that could, through impact and/or fire, release radionuclides or toxic chemicals. If the frequency of hitting a facility and causing either scabbing or perforation is greater than 1×10^{-6} , the DOE standard requires that a consequence analysis be performed (DOE 1996c).

Calculation of Facility Effective Area. The total effective area of a facility is the sum of the true area (the facility base area adjusted for aircraft dimension), the shadow area (defined by the facility height and the angle of postulated impact), and the skid area (the area covered by a skidding aircraft after impact with the ground).

The analysis was done on a building-by-building basis, treating each facility individually. The topographic features of the LANL site are such that the actual skid distances

can be less than the skid distances given in the DOE standard. Subsequently, the skid distances were reduced based on actual site conditions. The majority of reduced skid distances affect only commercial and military aircraft. The angle of impact chosen was based on the values presented in the DOE standard (DOE 1996c). A total effective area for each facility was calculated using the reduced skid distance.

Table G.4.1.3–3 presents the various building dimensions. Table G.4.1.3–4 presents the aircraft operational data used, including the skid distances. Both the DOE standard and maximum wingspans for aircraft in the vicinity of LAM are given. Maximum wingspans were determined by selecting representative aircraft from *Jane's All the World's Aircraft* (Jane's 1995). The skid distances in the table correspond to the skid distances presented in DOE Standard 3014-96 (DOE 1996c).

Hit Frequency Calculation. Based on the center-line and perpendicular distances to the TA facilities of interest, all aircraft using LAM were analyzed using the near-airport model. The impact frequency was obtained for each facility by multiplying the number of flights, the impact area, the crash rate, and the crash density function for each category. Table G.4.1.3–5 contains the crash frequencies for landings, takeoffs, and the nonairport aircraft for each facility.

Structural Calculation. For this analysis, 70th percentile velocities of aircraft were used (LLNL 1996). The velocities chosen were in either takeoff or landing operations, whichever was the largest. For facilities with overburden, these velocities were reduced according to the earth overburden velocity reduction equation.

The local response equations for rigid missiles impacting reinforced concrete structures were applied to applicable facilities, and the local response steel equations for rigid missiles were applied to applicable facilities. A reduction in penetration depth was taken because the

TABLE G.4.1.3-3.—LANL Building Dimensions

BUILDING	BUILDING LENGTH (ft)	BUILDING WIDTH (ft)	BUILDING HEIGHT (ft)	WALL THICKNESS (in.)	ROOF THICKNESS (in.)
TA-3-29 CMR	550	254	50	8	6
TA-3-476	18	12	9	0	0
TA-16-205 WETF	131	112	14	8	4
TA-16-411	87	24	20	8	6
TA-21-155 TSTA	70	15	26	1	3
TA-21-209 TSFF	40	35	20	1	2
TA-50-37 RAMROD	142	110	46	8	24
TA-50-69 Container Storage Area	90	24	6	0	0
TA-54 TWISP	414	286	38	0	0
TA-55-4	284	265	22	14	10
TA-18-26 Hs. Vault	18	12	10	18	12
TA-18-32 Kiva #2	59	58	25	15	4
TA-18-116 Kiva #3	81	64	36	18	8
TA-55-185	60	40	14	0	0
TA-8-22	42	39	21	8	8
TA-8-23	48	40	30	30	6
TA-15 DARHT	6	6	6	0	0
TA-18-23 Kiva #1	61	48	26	8	3
TA-18-168 SHEBA	20	20	18	0	0
TA-54-38 Container Storage Area	12	8	6	0	0

Source: Safety analysis documentation, site location maps, and miscellaneous sources

Note: TSTA and TSFF wall thicknesses are based on an approximate reinforced concrete equivalence for concrete block, based on the Pantex EIS analysis of similar construction (DOE 1996a).

TABLE G.4.1.3-4.—Aircraft Operational Data: Takeoff, In Flight, and Landing

	AIR CARRIER	AIR TAXI	LARGE MILITARY	SMALL MILITARY	GENERAL AVIATION			
					SINGLE ENGINE	MULTI-ENGINE	TURBOPROP	TURBOJET
DOE Standard Wingspan (ft)	98	59 ^b	223	78	50	50	73	50
Maximum Wingspan (ft)	211	75	223	93	50	50	80	78
Takeoff Skid Length (ft)	1,440	1,440	780 ^a	246	60	60	60	60
Landing Skid Length (ft)	1,440	1,440	368	447 ^a	60	60	60	60

^a Conservatively used for inflight.

^b Actual wingspan is 65 feet. This wingspan is used in the calculation and does not change the overall hit frequency because hit frequency is dominated by general aviation.

Source: DOE 1996c, Jane's 1995, and calculated values

TABLE G.4.1.3-5.—Aircraft Crash Frequencies

CRASH FREQUENCIES (PER YEAR)				
BUILDING	TAKEOFF	LANDING	NONAIRPORT	TOTAL
TA-3-29 CMR	7.1×10^{-8}	5.0×10^{-6}	3.6×10^{-6}	8.6×10^{-6}
TA-3-476	1.6×10^{-9}	1.1×10^{-7}	8.5×10^{-8}	2.0×10^{-7}
TA-16-205 and TA-16-205A	0	1.7×10^{-7}	4.7×10^{-7}	6.4×10^{-7}
TA-16-411 ^a	0	1.4×10^{-7}	2.8×10^{-7}	4.1×10^{-7}
TA-21-155 TSTA	1.3×10^{-5}	2.7×10^{-5}	2.7×10^{-7}	4.1×10^{-5}
TA-21-209 TSFF	1.0×10^{-5}	2.1×10^{-5}	2.1×10^{-7}	3.1×10^{-5}
TA-50-37 RAMROD	1.8×10^{-6}	2.8×10^{-6}	9.5×10^{-7}	5.5×10^{-6}
TA-50-69 Container Storage Area	2.9×10^{-7}	4.5×10^{-7}	1.6×10^{-7}	9.0×10^{-7}
TA-54 TWISP	8.9×10^{-7}	7.4×10^{-7}	2.6×10^{-6}	4.3×10^{-6}
TA-55-4	4.5×10^{-6}	4.5×10^{-6}	1.5×10^{-6}	1.1×10^{-5}
TA-18-26	3.2×10^{-9}	3.0×10^{-8}	5.5×10^{-8}	8.8×10^{-8}
TA-18-32	1.8×10^{-8}	1.8×10^{-7}	3.1×10^{-7}	5.1×10^{-7}
TA-18-116	3.2×10^{-8}	2.0×10^{-7}	4.8×10^{-7}	7.1×10^{-7}
TA-55-185	7.3×10^{-8}	6.0×10^{-7}	2.1×10^{-7}	8.9×10^{-7}
TA-8-22 ^b	0	9.1×10^{-8}	2.3×10^{-7}	3.2×10^{-7}
TA-8-23 ^b	0	1.2×10^{-7}	3.0×10^{-7}	4.3×10^{-7}
TA-15 DARHT ^a	0	1.0×10^{-8}	4.9×10^{-8}	5.9×10^{-8}
TA-18-23	1.8×10^{-8}	1.7×10^{-7}	3.1×10^{-7}	5.0×10^{-7}
TA-18-168	7.7×10^{-9}	7.4×10^{-8}	1.3×10^{-7}	2.2×10^{-7}
TA-54-38 Container Storage Area	3.2×10^{-9}	3.1×10^{-8}	5.5×10^{-8}	8.9×10^{-8}

Source: calculated values

^a Note: This is the raw crash frequency for this facility. There is a conditional probability of MAR being present that must be multiplied times the crash frequency to obtain the frequency of a crash with MAR present. The conditional probability is classified for this facility.

^b Note: This is the raw crash frequency for this facility. There is a conditional probability of MAR being present that must be multiplied times the crash frequency to obtain the frequency of a crash with MAR present. The conditional probability is less than 5 percent.

missiles were nonrigid. In cases where the structural equations presented in the DOE standard do not apply (e.g., due to the facility construction), it was assumed that significant building damage to these facilities was a certainty (i.e., probability of 1, given impact). In this analysis, the aircraft engine was investigated as the missile of concern. These engines were treated in the equations as nonrigid missiles. Table G.4.1.3–6 presents maximum engine weights and diameters for aircraft landing and taking off at LAM. Maximum engine weights and diameters were determined by selecting representative aircraft from *Jane's All the World's Aircraft* (Jane's 1995). Maximum engine weights and diameters were then used in the structural calculations.

Local response structural calculations were performed for the various overburden and building thicknesses. Table G.4.1.3–7 presents the results for perforation.

Perforation and Scabbing Frequency Calculation. For this analysis, it was assumed that for facilities such as the TRU waste domes in TA-54, which are constructed of a rigid arch frame covered by a tensioned membrane, the

release frequency due to aircraft crash is the same as the hit frequency. For facilities with high explosives, the bounding accident is a perforation or scab leading to an explosion. For facilities without high explosives, the bounding accident is a perforation leading to a fire. Scabbing leading to an explosion in steel facilities is not possible because steel does not scab. The areas for the facilities were reduced using the structural analysis results. The reduced areas were then used to recalculate perforation and scabbing frequencies. Table G.4.1.3–8 presents the frequencies of perforation leading to an explosion, and Table G.4.1.3–9 presents the frequencies of perforation leading to a fire for landings, takeoffs, and the nonairport aircraft for each facility.

The true, shadow, and skid areas for the various facilities were reduced for perforation and scabbing (Table G.4.1.3–7). If the facility roof does not sustain damage, then the true area is reduced to zero. If the facility walls do not sustain damage, then the shadow and skid areas are reduced to the width of the building times the skid distance.

TABLE G.4.1.3–6.—Aircraft Missile Characteristics

AIRCRAFT CATEGORY	IMPACT VELOCITY (ft/sec)	ENGINE WEIGHT (lb)	ENGINE DIAMETER (in.)
Air Carrier	282	9,874	86
Air Taxi	282	861	31
Large Military	439	8,731	105
Small Military	513	4,201	51
Single-Engine Piston	152	500	30
Multiple-Engine Piston	152	596	25
Turboprop	152	465	19
Turbojet	152	2,574	37

Sources: LLNL 1996 and Jane's 1995. Impact velocities are based on 70th percentile values, corresponding to the skid distance values used in DOE Standard 3014-96 (DOE 1996c) and this analysis.

TABLE G.4.1.3-7.—Structural Perforation Calculation Summary

BUILDING	AIR CARRIER		AIR TAXI		LARGE MILITARY		SMALL MILITARY		GENERAL AVIATION							
	R	W	R	W	R	W	R	W	SINGLE ENGINE		MULTIPLE ENGINE		TURBO PROP		TURBO JET	
	R	W	R	W	R	W	R	W	R	W	R	W	R	W	R	W
TA-3-29	X	X	X	X	X	X	X	X	X		X		X		X	X
TA-3-476	X	X	X	X	X	X	X	X	X	X	X	X	X	X	X	X
TA-16-205	X	X	X	X	X	X	X	X	X		X		X		X	X
TA-16-411	X	X	X	X	X	X	X	X	X		X		X		X	X
TA-21-155	X	X	X	X	X	X	X	X	X		X		X		X	X
TA-21-209	X	X	X	X	X	X	X	X	X		X		X		X	X
TA-50-37	X	X		X	X	X	X	X								X
TA-50-69	X	X	X	X	X	X	X	X	X	X	X	X	X	X	X	X
TWISP	X	X	X	X	X	X	X	X	X	X	X	X	X	X	X	X
TA-55-4	X	X	X	X	X	X	X	X								X
TA-18-26	X	X			X											
TA-18-32	X	X	X	X	X	X	X	X	X		X		X		X	
TA-18-116	X	X	X	X	X	X	X	X							X	
TA-55-185	X	X	X	X	X	X	X	X	X	X	X	X	X	X	X	X
TA-8-22	X	X	X	X	X	X	X	X							X	X
TA-8-23	X	X	X		X	X	X		X		X		X		X	
DARHT	X	X	X	X	X	X	X	X	X	X	X	X	X	X	X	X
TA-18-23	X	X	X	X	X	X	X	X	X		X		X		X	X
TA-18-168	X	X	X	X	X	X	X	X	X	X	X	X	X	X	X	X
TA-54-38	X	X	X	X	X	X	X	X	X	X	X	X	X	X	X	X

R = Roof

W = Walls

X = Damage; perforation occurs.

Blank = No damage; perforation does not occur.

Source: Calculated values

TABLE G.4.1.3-8.—Aircraft Crash Frequencies per Year for Perforation Leading to Explosion

BUILDING	FREQUENCY (PER YEAR)			
	TAKEOFF	LANDING	NONAIRPORT	TOTAL
TA-3-29	0	0	0	0
TA-3-476	1.6×10^{-9}	1.1×10^{-7}	8.5×10^{-8}	2.0×10^{-7}
TA-16-205	0	0	0	0
TA-16-411	0	1.7×10^{-8}	5.0×10^{-8}	6.7×10^{-8}
TA-21-155	0	0	0	0
TA-21-209	0	0	0	0
TA-50-37	0	0	0	0
TA-50-69 Container Storage Area	0	0	0	0
TA-54 TWISP	0	0	0	0
TA-55-4	0	0	0	0
TA-18-26	0	0	0	0
TA-18-32	0	0	0	0
TA-18-116	0	0	0	0
TA-55-185	0	0	0	0
TA-8-22	0	$< 1.0 \times 10^{-9}$	1.6×10^{-8}	1.6×10^{-8}
TA-8-23	0	1.5×10^{-8}	4.7×10^{-8}	6.3×10^{-8}
DARHT	0	1.0×10^{-8}	4.9×10^{-8}	5.9×10^{-8}
TA-18-23	0	0	0	0
TA-18-168	0	0	0	0
TA-54-38 Container Storage Area	0	0	0	0

Source: Calculated values

TABLE G.4.1.3-9.—Aircraft Crash Frequency per Year for Perforation Leading to Fire

BUILDING	FREQUENCY (PER YEAR)			
	TAKEOFF	LANDING	NONAIRPORT	TOTAL
TA-3-29 CMR	2.7×10^{-8}	2.0×10^{-6}	1.5×10^{-6}	3.5×10^{-6}
TA-3-476	1.6×10^{-9}	1.1×10^{-7}	8.5×10^{-8}	2.0×10^{-7}
TA-16-205 and TA-1-205A WETF	$< 1.0 \times 10^{-9}$	6.3×10^{-8}	1.9×10^{-7}	2.6×10^{-7}
TA-16-411 Assembly Building	$< 1.0 \times 10^{-9}$	1.7×10^{-8}	5.0×10^{-8}	6.7×10^{-8}
TA-21-155 TSTA	1.0×10^{-6}	2.8×10^{-6}	3.5×10^{-8}	3.8×10^{-6}
TA-21-209 TSFF	1.6×10^{-6}	3.7×10^{-6}	4.2×10^{-8}	5.3×10^{-6}
TA-50-37 RAMROD	6.7×10^{-9}	1.4×10^{-8}	4.4×10^{-8}	6.5×10^{-8}
TA-50-69 Container Storage Area	2.9×10^{-7}	4.5×10^{-7}	1.7×10^{-7}	9.0×10^{-7}
TA-54 TWISP	8.9×10^{-7}	7.4×10^{-7}	2.6×10^{-6}	4.3×10^{-6}
TA-55-4 Plutonium Facility	$< 1.0 \times 10^{-9}$	3.3×10^{-9}	8.0×10^{-6}	8.4×10^{-8}
TA-18-26 Hillside Vault	$< 1.0 \times 10^{-9}$	$< 1.0 \times 10^{-9}$	$< 1.0 \times 10^{-9}$	$< 1.0 \times 10^{-9}$
TA-18-32 Kiva #2	4.3×10^{-9}	3.2×10^{-8}	7.3×10^{-8}	1.1×10^{-7}
TA-18-116 Kiva #3	$< 1.0 \times 10^{-9}$	$< 1.0 \times 10^{-9}$	1.6×10^{-8}	1.6×10^{-8}
TA-55-185 TRU Staging	7.3×10^{-8}	6.0×10^{-7}	2.1×10^{-7}	8.9×10^{-7}
TA-8-22 Radiography	$< 1.0 \times 10^{-9}$	$< 1.0 \times 10^{-9}$	1.6×10^{-8}	5.5×10^{-8}
TA-8-23 Radiography	$< 1.0 \times 10^{-9}$	1.5×10^{-8}	3.9×10^{-8}	5.9×10^{-8}
TA-15 DARHT	$< 1.0 \times 10^{-9}$	1.0×10^{-8}	4.9×10^{-8}	5.9×10^{-8}
TA-18-23 Kiva #1	3.9×10^{-9}	2.8×10^{-8}	6.7×10^{-8}	9.9×10^{-8}
TA-18-168 SHEBA	7.7×10^{-9}	7.4×10^{-8}	1.3×10^{-7}	2.2×10^{-7}
TA-54-38 Container Storage Area	3.2×10^{-9}	3.1×10^{-8}	5.5×10^{-8}	8.9×10^{-8}

Source: Calculated values

Note: In the cases of TA-8-22, TA-8-23, TA-15 DARHT, and TA-16-411, there is a conditional probability significantly less than one of MAR actually being present.

Discussion of Aircraft Crash and Release Frequencies

The aircraft crash frequencies in Table G.4.1.3–5 provide an indication of the frequency with which personnel injuries or fatalities could occur as a result of an aircraft crash at the facilities listed in the table. Note that a crash is not necessarily equivalent to a release of hazardous material; however, the conditional probability of a release given a crash is dependent on the design and construction of the facility and the nature of the aircraft impacting the facility.

Two types of release scenarios were considered: perforation leading to an explosion and perforation leading to a fire. The perforation-induced explosion results are presented in Table G.4.1.3–8. The results, particularly when the conditional probability of explosives being present is taken into account, indicate that perforation-induced explosion is a very minor contributor to risk. With the exception of the TA–3–476 facility, the other facilities potentially affected have perforation-induced explosion frequencies of less than 1×10^{-8} per year. This frequency is so low compared with the seismic structural damage/collapse scenarios (which can result in a large source term) that perforation-induced explosion is not considered further.

The perforation-induced fire results indicate that four facilities with hazardous materials have perforation-induced fire frequencies above 1×10^{-6} per year. The frequency of perforation-induced fire aircraft crash events at these facilities was examined in comparison with the seismic structural damage/collapse scenarios in order to evaluate whether aircraft crash accidents needed to be evaluated in detail.

It is important to recognize that the DOE aircraft crash standard (DOE 1996c) was intended for use as a safety analysis screening tool. For facilities that, after full analysis in accordance with the standard, still have aircraft crash

frequencies in excess of the evaluation guidelines in the standard (crash frequency of greater than 1×10^{-6} per year), it was intended that a more detailed analysis be performed in order to determine whether aircraft crash should be considered to be an evaluation basis accident for safety analysis purposes. For NEPA purposes, the results indicate that the TA–3–29 (CMR), TA–21–155 (TSTA), TA–21–209 (TSFF), and TA–54 TWISP facilities dominate the aircraft crash-induced release frequency. The releases from TSTA and TSFF due to aircraft crash represent bounding tritium release scenarios for LANL because they occur at a relatively high frequency (compared with other large tritium release accidents) and, because of the accompanying fire, the tritium released would be in oxide form (which is more radiologically hazardous than elemental tritium gas).

Plutonium release from the CMR Building (RAD–16), plutonium release (from TRU waste) at TA–54 TWISP (RAD–08), and tritium oxide release from TSTA/TSFF (RAD–05) due to aircraft crash and fire were retained as risk-dominant accidents.

Having the crash frequency estimates, a consequence analysis was performed for each accident. (An analysis also was conducted for an “incredible” aircraft crash at RAMROD (RAD–06). The consequence analyses are similar to the consequence analyses for other accident scenarios, except that release fractions specified in the DOE aircraft crash standard (DOE 1996c) are used, rather than release fractions from DOE Standard 3010-94 (DOE 1994d).

The remaining perforation-induced fire scenarios identified in Table G.4.1.3–9 are considered to be bounded in risk by seismic release scenarios that occur at a much higher frequency. (Seismic releases occur in the frequency range of to 7.1×10^{-5} to 2.9×10^{-3} per year; whereas, the remaining aircraft crash with perforation-induced fire releases occur in the

frequency range from to 1.3×10^{-10} to 8.9×10^{-7} per year.) For an aircraft crash accident to dominate over a seismic release for the remaining facilities, the source term for the aircraft crash accident would have to be orders of magnitude greater than for the seismic structural damage/collapse. No such release potential was identified.

G.4.2 Accident Source Term Assessment

The “source term” is a description of the physical and chemical characteristics of the materials released inside the facility or to the environment. The source term parameters include not only the MAR and the amount and rate of release, but also parameters that determine the subsequent transport, dispersion, and effects. These include whether the material is gas or particulate, in elemental or oxide form (e.g., for tritium and plutonium), and whether the release occurs at ground level or at some elevation above the ground. The plume source height is determined by the intensity of the fire or explosion, or, if the release is from a stack, the stack parameters (e.g., stack height diameter and velocity, heat content, etc.).

G.4.2.1 Chemical Accident Source Terms

Chemical accident source terms are estimated in a straightforward manner for the SWEIS. The screening analysis identified toxic gases and liquids that could easily disperse in the event of an accident. The source terms are based on the MAR quantities appropriate to the accident initiator. For example, in the case of a building structural collapse due to an earthquake, the entire gaseous/liquid chemical contents of the building are assumed to be released. For a process-related accident, such as the failure of a valve on a 150-pound capacity cylinder of chlorine, the source term is the maximum contents of the cylinder (even though it is

recognized that the container may not be full when the valve failure occurs).

Where there are physical constraints on the release, these are recognized in the modeling. The 150-pound chlorine cylinder release is a good illustration of this sort of constraint. The chlorine inventory in the cylinder is partially gaseous and partially liquid. When the valve fails, the gaseous chlorine depressurizes very quickly, releasing a jet of liquid. However, this act results in a cooling of the cylinder below the boiling temperature of the liquid chlorine, halting the large release. As a result, not all 150 pounds of chlorine are released quickly. Simulation predicts the release of 68 pounds in the first 45 seconds at a flow rate of 91.5 pounds per minute. The flow rate then decreases sharply (Gephart and Moses 1989). The remaining chlorine would be released slowly as the container heats up to ambient temperature. Such a slow release rate would not pose significant hazards downwind of the release point. This type of release can be modeled with ALOHA™.

In some cases, conservative assumptions must be made in order to model the accident. A good example of this is the fire at TA-3-476, which results in chlorine release by melting fusible plugs in the chlorine cylinders (which melt at 165°F [74°C] and release the chlorine at a pre-defined rate in order to prevent sudden rupture of the cylinder). There are potentially ten affected cylinders in this accident. In reality, not all ten would release at exactly the same time. Due to modeling limitations, however, it was necessary to assume a simultaneous release. This is a conservative and bounding representation of the accident, but is not necessarily the most realistic portrayal of the accident. Table G.4.2.1-1 provides a summary of source terms for the chemical accidents.

TABLE G.4.2.1-1.—*Summary of Chemical Accident Source Term Calculations*

ACCIDENT SCENARIO DESIGNATOR	AFFECTED FACILITY	CHEMICAL RELEASED	SOURCE TERM INFORMATION
CHEM-01	TA-00-1109	chlorine	150 pounds
CHEM-02	TA-3-476	chlorine	1,500 pounds
CHEM-03	TA-3-476	chlorine	150 pounds
CHEM-04	TA-54-216	selenium hexafluoride	75 liters
CHEM-05	TA-54-216	sulfur dioxide	300 pounds
CHEM-06	TA-55-4	chlorine	150 pounds
SITE-01	TA-00-1109	chlorine	300 pounds
	TA-00-1110	chlorine	300 pounds
	TA-3-66	hydrogen cyanide	7.6 liters
	TA-3-476	chlorine	150 pounds
	TA-9-21	phosgene	3 pounds
	TA-43-1	formaldehyde	30 liters
SITE-02	TA-00-1109	chlorine	300 pounds
	TA-00-1110	chlorine	300 pounds
	TA-3-66	hydrogen cyanide	7.6 liters
	TA-3-476	chlorine	150 pounds
	TA-9-21	phosgene	3 pounds
	TA-43-1	formaldehyde	30 liters
	TA-55-4	chlorine	150 pounds
	TA-55-4	nitric acid	6,100 gallons
TA-55-249	hydrochloric acid	5,200 gallons	
SITE-03	TA-00-1109	chlorine	300 pounds
	TA-00-1110	chlorine	300 pounds
	TA-3-66	hydrogen cyanide	7.6 liters
	TA-3-476	chlorine	150 pounds
	TA-9-21	phosgene	3 pounds
	TA-43-1	formaldehyde	30 liters
	TA-55-4	chlorine	150 pounds
	TA-55-4	nitric acid	6,100 gallons
	TA-55-249	hydrochloric acid	5,200 gallons
SITE-04	TA-43-1	formaldehyde	30 liters

G.4.2.2 Radiological Accident Source Terms

DOE has issued standard guidance on estimating source terms for nonreactor nuclear facility accidents as DOE Handbook 3010-94 (DOE 1994d). (Note: aircraft crash source terms were not calculated using DOE Handbook 3010-94. Rather, DOE Standard 3014-96 specifies the source term methodology for aircraft crash accidents. Although DOE Standard 3014-96 cites DOE Handbook 3010-94 as a basis for its values, there are differences, and DOE Standard 3014-96 was used for aircraft crash accidents.)

DOE Handbook 3010-94 received extensive peer review within the DOE technical community and is the best available current information on the subject. Although the handbook presents both median and bounding values in many cases, this accident analysis employs the bounding values. (Accordingly, where SARs have used more realistic, less conservative source terms, the SARs have projected lesser consequences.) Although the availability of a median and bounding estimate might result in a temptation to generate a statistical distribution of values, the handbook specifically cautions against such an approach (DOE 1994d):

“The generation and suspension of particles is the result of the interaction of multiple physiochemical variables that have not been completely characterized as the majority of the experiments performed were designed in an attempt to reflect reasonably bounding conditions for specific industrial situations of concern. Accordingly, the data obtained are more accurately characterized as selected points from multiple distributions against multiple parameters than as different values from a common distribution. Even if this point is neglected, there are still practically intractable problems in attempting to generate statistical distributions. While the data are presumed to be bounding for the purpose intended, it is largely unknown whether the data values are truly 90th percentile, 99th percentile, 99.9th percentile, etc. Further, in many cases it is considered likely that accident specific ARFs are actually distributed in a highly irregular manner (i.e., multi-modal or truncated distributions). Assuming a typical distribution (i.e., log-normal, Poisson) using standard deviations will produce seriously distorted values that may have little or nothing to do with reality.”

The handbook also cautions against over reliance on the values contained therein (DOE 1994d). Table G.4.2.2–1 provides the details of source terms for radiological accidents.

TABLE G.4.2.2-1.—Source Terms of Radiological Accidents at LANL

ACCIDENT SCENARIO DESIGNATOR	AFFECTED FACILITY	MATERIAL RELEASED	SOURCE TERM INFORMATION
SITE-01	TA-3-29	Pu-239	96.9 g of Pu-239 initial; 9.4 g suspension
	TA-18-23	HEU	22.9 g of HEU initial; 0.22 g suspension
	TA-21-155	tritium oxide	200 g of tritium oxide
	TA-21-209	tritium oxide	200 g of tritium oxide
	TA-50-1	Pu-238, Pu-239, Am-241	5.8 x 10 ⁻⁵ g of Pu-238, 0.27 g of Pu-239 & 0.005 g of Am-241 initial; 1.3 x 10 ⁻⁴ g Pu-238, 5.85 g Pu-239 & 0.11g of Am-241 suspension
	TA-50-37	Pu-239	1.0 Pu-239 PE-Ci initial; 0.96 Pu-239 PE-Ci suspension
	TA-54-38	Pu-239	0.339 Pu-239 PE-Ci initial; 0.033 Pu-239 PE-Ci suspension
	TWISP	Pu-239	0.19 Pu-239 PE-Ci initial; 1.2 Pu-239 PE-Ci suspension
SITE-02	TA-3-29	Pu-239	102.8 g of Pu-239 initial; 9.4 g suspension
	TA-16-205	tritium oxide	100 g of tritium oxide
	TA-18-23	HEU	22.9 g of HEU initial; 0.22 g suspension
	TA-18-32	Pu-239, HEU	0.22 g Pu-239
	TA-18-116	Pu-239, HEU	0.028 g Pu-239
	TA-18-168	HEU	0.85 g HEU initial; 18.4 g suspension
	TA-21-155	tritium oxide	200 g of tritium oxide
	TA-21-209	tritium oxide	200 g of tritium oxide
	TA-50-1	Pu-238, Pu-239, Am-241	5.8 x 10 ⁻⁵ g of Pu-238, 0.27 g of Pu-239 & 0.005 g of Am-241 initial; 1.3 x 10 ⁻⁴ g Pu-238, 5.85 g Pu-239 & 0.11 g of Am-241 suspension
	TA-50-37	Pu-239	1.0 Pu-239 PE-Ci initial; 0.96 Pu-239 PE-Ci suspension
	TA-50-69	Pu-239	0.39 Pu-239 PE-Ci initial; 0.037 Pu-239 PE-Ci suspension
	TA-54-38	Pu-239	0.339 Pu-239 PE-Ci initial; 0.033 Pu-239 PE-Ci suspension
	TWISP	Pu-239	0.12 Pu-239 PE-Ci initial; 1.2 Pu-239 PE-Ci suspension
TA-55-4	Pu-239, Pu-238, Pu-242, HEU	0.0174 g Pu-238, 5.31 g Pu-239, 0.201 g Pu-242 & 0.242 g HEU initial; 0.056 g Pu-238, 56.7 g Pu-239, 1.68 g Pu-242 & 0.025 g HEU suspension	

TABLE G.4.2.2-1.—Source Terms of Radiological Accidents at LANL-Continued

ACCIDENT SCENARIO DESIGNATOR	AFFECTED FACILITY	MATERIAL RELEASED	SOURCE TERM INFORMATION
SITE-03	TA-3-29	Pu-239	140.8 g Pu-239 initial; 13.1 g suspension
	TA-16-205	tritium oxide, tritium gas	172 g of tritium oxide, 1,188 g tritium gas
	TA-18-23	HEU	22.9 g of HEU initial; 0.22 g suspension
	TA-18-32	Pu-239, HEU	0.22 g of Pu-239
	TA-18-116	Pu-239, HEU	0.028 g of Pu-239
	TA-18-168	HEU	0.85 g HEU initial; 18.4 g suspension
	TA-21-155	tritium oxide	200 g of tritium oxide
	TA-21-209	tritium oxide	200 g of tritium oxide
	TA-50-1	Pu-238, Pu-239, Am-241	5.8x10 ⁻⁵ g of Pu-238, 0.27 g of Pu-239 & 0.005 g of Am-241 initial; 1.3x10 ⁻⁴ g Pu-238, 5.85 g Pu-239 & 0.11 g of Am-241 suspension
	TA-50-37	Pu-239	1.0 Pu-239 PE-Ci initial; 0.96 Pu-239 PE-Ci suspension
	TA-50-69	Pu-239	0.39 Pu-239 PE-Ci initial; 0.037 Pu-239 PE-Ci suspension
	TA-54-38	Pu-239	0.339 Pu-239 PE-Ci initial; 0.033 Pu-239 PE-Ci suspension
	TWISP	Pu-239	0.25 Pu-239 PE-Ci initial; 2.4 Pu-239 PE-Ci suspension
	TA-55-4	Pu-239, Pu-238, Pu-242, HEU	2.04 g Pu-238, 69.2 g Pu-239, 0.062 g Pu-240, 3.36 g Pu-242 & 3.74 g HEU initial; 1.95 g Pu-238, 71.2 g Pu-239, 0.3 g Pu-240, 3.22 g Pu-242 & 3.6 g HEU suspension
TA-55-185	Pu-239	0.006 Pu-239 PE-Ci initial; 0.06 Pu-239 PE-Ci suspension	
SITE-03, Surface Rupture	TA-3-29	Pu-239	788.5 g Pu-239 initial; 27.6 g suspension
	TA-16-205	tritium oxide, tritium gas	172 g of tritium oxide, 1,188 g tritium gas
	TA-18-23	HEU	22.9 g of HEU initial; 0.22 g suspension
	TA-18-32	Pu-239, HEU	0.22 g of Pu-239
	TA-18-116	Pu-239, HEU	0.028 g of Pu-239
	TA-18-168	HEU	0.85 g HEU initial; 18.4 g suspension
	TA-21-155	tritium oxide	200 g of tritium oxide
	TA-21-209	tritium oxide	200 g of tritium oxide
	TA-50-1	Pu-238, Pu-239, Am-241	5.8x10 ⁻⁵ g of Pu-238, 0.27 g of Pu-239 & 0.005 g of Am-241 initial; 1.3x10 ⁻⁴ g Pu-238, 5.85 g Pu-239 & 0.11 g of Am-241 suspension
	TA-50-37	Pu-239	1.0 Pu-239 PE-Ci initial; 0.96 Pu-239 PE-Ci suspension
	TA-50-69	Pu-239	0.39 Pu-239 PE-Ci initial; 0.037 Pu-239 PE-Ci suspension
	TA-54-38	Pu-239	0.339 Pu-239 PE-Ci initial; 0.033 Pu-239 PE-Ci suspension
	TWISP	Pu-239	0.25 Pu-239 PE-Ci initial; 2.4 Pu-239 PE-Ci suspension
	TA-55-4	Pu-239, Pu-238, Pu-242, HEU	2.04 g Pu-238, 69.2 g Pu-239, 0.062 g Pu-240, 3.36 g Pu-242 & 3.74 g HEU initial; 1.95 g Pu-238, 71.2 g Pu-239, 0.3 g Pu-240, 3.22 g Pu-242 & 3.6 g HEU suspension
TA-55-185	Pu-239	0.006 Pu-239 PE-Ci initial; 0.06 Pu-239 PE-Ci suspension	
SITE-04	TA-16-205	tritium gas	1,360 g tritium gas
	TA-21-155	tritium oxide	200 g tritium oxide
	TA-21-209	tritium oxide	100 g tritium oxide
	TA-54	Pu-239	0.16 Pu-239 PE-Ci initial release (elevated); 0.74 Pu-239 PE-Ci suspension release (ground level)
RAD-01	TA-54-38	Pu-239	0.13 Pu-239 PE-Ci initial release (elevated); 0.60 Pu-239 PE-Ci suspension release (ground level)
RAD-02	TA-3-29	Pu-239	504 g Pu-239 released in 60 seconds (explosion), 6 g Pu-239 released in 2 hours (fire), 0.48 g Pu-239 suspension release (ground level)

TABLE G.4.2.2-1.—Source Terms of Radiological Accidents at LANL-Continued

ACCIDENT SCENARIO DESIGNATOR	AFFECTED FACILITY	MATERIAL RELEASED	SOURCE TERM INFORMATION
RAD-03	TA-18-116	HEU, Fission Products	7,194 g HEU and fission products initial release (ground level); 56.1 g HEU suspension release (ground level)
RAD-04	DARHT	Pu	Elevated release of Pu
RAD-05	TA-21-155 and/or TA-21-209	tritium oxide	200 g tritium oxide, elevated release (fire), no suspension release
RAD-06	TA-50-37	Pu-239	0.63 Pu-29 PE-Ci released in 30 minutes (elevated release); 2.8 Pu-239 PE-Ci suspension release (ground level)
RAD-07	TA-50-69 Container Storage Area	Pu-239	0.28 Pu-239 PE-Ci released in 2.4 minutes (elevated); 0.52 Pu-239 PE-Ci suspension release (ground level)
RAD-08	TWISP	Pu-239	0.16 Pu-239 PE-Ci initial release (elevated); 0.74 Pu-239 PE-Ci suspension release (ground level)
RAD-09	TWISP	Pu-239	High activity container, 0.066 Pu-239 PE-Ci initial release (ground level); 0.63 Pu-239 PE-Ci suspension release (ground level); Average activity container, 0.0012 Pu-239 PE-Ci initial release, 0.012 Pu-239 PE-Ci suspension release
RAD-10	TA-55-4	Weapons-Grade Pu	2.7 g weapons-grade Pu initial release (stack); 4.3 g weapons-grade Pu suspension release (ground level)
RAD-11	DARHT	Pu	Ground-level release of Pu
RAD-12	TA-16-411	Pu	Elevated release of plutonium
RAD-13	TA-18-116	Weapons-Grade Pu, Fission Products	6 g weapons-grade Pu initial release, plus fission products (ground level); 0.6 g weapons-grade Pu suspension release (ground level)
RAD-14	TA-55-4	Weapons-Grade Pu	2.5 g weapons-grade Pu initial release (stack); 0.0983 g weapons-grade Pu suspension release (ground level)
RAD-15	TA-3-29	Weapons-Grade Pu	6.6 g weapons-grade Pu initial release; 4.34 g weapons-grade Pu suspension release (Expanded Operations Alternative only)
RAD-16	TA-3-29	Pu-239	0.69 g Pu-239 initial release (elevated); 0.21 g Pu-239 suspension release (ground level)

Note: As plutonium-239 (Pu-239) ages, there is an ingrowth of the daughter americium-241 (Am-241) that affects the gamma radiation levels. However, an analysis shows that health effects from the combined uptake are quite independent of the aging. Therefore, the MAR does not distinguish as to age of the material released.

G.5 ACCIDENT CONSEQUENCE ASSESSMENT

This section provides the detailed description and analysis results for each of the accident scenarios for which impact quantification is performed. Table G.5–1 provides a summary of the consequences to the public from risk-significant accidents at LANL. The annual frequency at which these consequences occur (that is, their probability of occurrence in any year), can be put into a common perspective by reference to Table G.1–2. When the term “societal risk” is encountered, recall that the product of consequence and probability is called societal risk in the SWEIS. It permits the ready comparison of accidents and alternatives without the burden of the details found in this section.

G.5.1 Note on Worker Consequences

Table G.5.1–1 provides a similar summary for consequences to workers in the facilities at which the accidents originate. The consequences are characterized rather than quantified. In most cases, it is possible to estimate the number or range in number of people that may be present as determined from experience, the size of the task, or administrative limits. However, it is not generally possible to quantify the number of injuries and fatalities this close to the source because: (1) the details of the contaminant distribution, fires, projectiles, and explosive forces close to the accident point are not known and are not predictable; (2) the numbers and locations of workers change frequently; and (3) worker response, which has a large effect in increasing or decreasing consequences, is not predictable.

G.5.2 Note on Soil Contamination

There is also soil contamination that results from deposition of plumes from radiological releases. When provided by the model, the predicted mean soil contamination levels are given in tables at the end of the descriptions of those radiological accidents that release more than a small amount of uranium or plutonium. (There is negligible deposition of tritium on soil.) The deposited material may subsequently become airborne by wind or other disturbances. The resulting potential for exposures through inhalation is small compared to the initial plume; nevertheless, the dose from such is calculated in the modeling and is included in the exposures in Table G.5–1.

Over the long term, the soil contamination has potential for further exposure through inhalation of air and ingestion of food products. The federal government, under the Federal Radiological Emergency Response Plan (61 Federal Register [FR] 20944), responds to a radiological emergency and provides resources to assist in the evaluation and mitigation of potential long-term exposure pathways to humans. Specifically, EPA will assume responsibility from DOE for long-term monitoring and remediation, assist in the preparation of area restoration plans, and recommend cleanup criteria. The U.S. Department of Agriculture (USDA) will inspect meat and meat products, poultry and poultry products, and egg products to ensure they are safe for human consumption. In addition, the USDA in conjunction with the U.S. Department of Health and Human Services (HHS) will assist in monitoring the production, processing, storage, and distribution of food through the wholesale level to eliminate or reduce contamination to a safe level. HHS will assist with the assessment, preservation, and protection of human health, and will assist state and local governments in making evacuation and relocation decisions.

TABLE G.5-1.—Summary of Consequences from Risk-Significant Accidents at LANL^a

SCENARIO	DESCRIPTION	BASELINE LIKELIHOOD ^b	BASELINE CONSEQUENCE MEASURES ^c	EFFECT OF ALTERNATIVES ^d
SITE-01	Moderate earthquake on the Pajarito Fault or a large earthquake in the Rio Grande Rift zone, resulting in structural damage and/or severe internal damage to comparatively low-capacity facilities.	Approximately 2.9×10^{-3} per year (i.e., one such event in approximately 350 years).	Mean population dose approximately 27,726 person-rem, resulting in approximately 16 excess LCFs; MEI dose 20 rem; several tens of people exposed at or above ERPG-2 or ERPG-3 levels at distances to a substantial fraction of 1 mile from multiple sources.	NOA—baseline. No difference among alternatives; the MAR and accident conditions are unaffected by the alternatives.
SITE-02	Large earthquake on the Pajarito Fault, resulting in structural damage and/or severe internal damage to low- and moderate-capacity facilities.	Approximately 4.4×10^{-4} per year (i.e., one such event in approximately 2,300 years).	Mean population dose approximately 41,340 person-rem, resulting in approximately 24 excess LCFs; MEI dose 34 rem; approximately 100 people exposed above ERPG-2 or ERPG-3 levels to a distance of about 1 mile from multiple sources.	NOA—baseline. No difference among alternatives; the MAR and accident conditions are unaffected by the alternatives.
SITE-03	Very large earthquake on the Pajarito Fault and perhaps the Embudo Fault, resulting in structural damage to essentially all facilities.	Approximately 7.1×10^{-5} per year (i.e., one such event in approximately 14,000 years).	Mean population dose approximately 210,758 person-rem, resulting in approximately 134 excess LCFs; MEI dose 247 rem; approximately 100 people exposed above ERPG-2 or ERPG-3 levels to a distance of about 1 mile from the sources.	NOA—baseline. No difference among alternatives; the MAR and accident conditions are unaffected by the alternatives.
SITE-03, Surface Rupture	Very large earthquake on the Pajarito Fault, resulting in structural damage to essentially all facilities with surface rupture possible on subsidiary faults.	Approximately 1 to 3×10^{-5} per year (i.e., one such event in 95,000 to 32,000 years).	Mean population dose approximately 344,581 person-rem, resulting in approximately 233 excess LCFs; MEI dose < 380 rem; approximately 100 people exposed above ERPG-2 or ERPG-3 levels to a distance of about 1 mile from multiple sources.	NOA—baseline. No difference among alternatives; the MAR and accident conditions are unaffected by the alternatives.
SITE-04	Site-wide wildfire consuming combustible structures and vegetation.	Approximately 0.1 per year (i.e., one every 10 years).	Mean population dose approximately 675 person-rem, resulting in approximately 0.34 excess LCFs; MEI dose < 25 rem; potential for limited exposure to chemicals.	NOA—baseline. No difference among alternatives; the MAR and accident conditions are unaffected by the alternatives.
CHEM-01	Large leak chlorine release (69 to 75 lb) from potable water treatment station due to human error during cylinder changeout or maintenance, or due to random hardware failures.	Approximately 1.2×10^{-3} per year (i.e., one such event in approximately 800 years).	For the risk-dominant large leak scenario, an average of approximately 43 people exposed above ERPG-2 levels, and approximately 12 people exposed above ERPG-3 levels to distances of up to a few tenths of 1 mile.	NOA—baseline. EXP—approximately 5% more likely. RED—approximately 5% less likely. GRN—same as baseline; no change in severity.

TABLE G.5-1.—Summary of Consequences from Risk-Significant Accidents at LANL^a-Continued

SCENARIO	DESCRIPTION	BASELINE LIKELIHOOD ^b	BASELINE CONSEQUENCE MEASURES ^c	EFFECT OF ALTERNATIVES ^d
CHEM-02	Multiple cylinder release (1,500 lb) from toxic release gas storage shed at Gas Plant due to fire or aircraft crash.	Approximately 1.3×10^{-4} per year (i.e., one in approximately 8,000 years).	Average of 292 people within LANL (ranging from none to 1,000 depending upon wind direction) exposed at or above ERPG-2 or ERPG-3 levels; town protected by canyon from highest concentrations.	NOA—baseline. EXP—approximately 14% more likely. RED—approximately 5% less likely. GRN—same as baseline; no change in severity.
CHEM-03	Chlorine release (68 to 75 lb) from toxic gas storage shed at Gas Plant due to random failure or human errors during cylinder handling.	Approximately 1.2×10^{-4} per year (i.e., one in approximately 8,000 years).	An average of approximately 263 people exposed above ERPG-2 levels or 239 above ERPG-3 levels at distances to a fraction of 1 mile, all within LANL; town protected by canyon from highest concentrations.	NOA—baseline. No difference among alternatives; the MAR and accident conditions are unaffected by the alternatives.
CHEM-04	Bounding single container release of toxic gas (selenium hexafluoride) from waste cylinder storage.	Approximately 4.1×10^{-3} per year (i.e., one in approximately 250 years).	Average number of off-site people exposed above ERPG-2 level is zero; toxic effects generally limited to the source's technical area (TA-54).	NOA—baseline. No change in likelihood or severity among the alternatives.
CHEM-05	Bounding multiple cylinder release of toxic gas (sulfur dioxide) from waste cylinder storage.	Approximately 5.1×10^{-4} per year (i.e., one event in approximately 2,000 years).	Under conservative daytime conditions, no one outside the source area (TA-54) would see levels above ERPG-2. Under least favorable conditions, 13 people could be exposed above ERPG-3 levels and 59 above ERPG-2 levels.	NOA—baseline. No change in likelihood or severity among the alternatives.
CHEM-06	Chlorine gas release outside Plutonium Facility.	Approximately 6.3×10^{-2} per year (i.e., one event in approximately 16 years).	Average number of people exposed at or above ERPG-2 doses is approximately 102, and above ERPG-3, approximately 7 at ranges to a fraction of 1 mile.	NOA—baseline. No change in likelihood or severity among the alternatives.
RAD-01 ^e	Plutonium release from RANT Facility transuranic waste container storage area fire.	Approximately 1.6×10^{-3} per year (i.e., one event in approximately 600 years).	Mean population dose approximately 72 person-rem, resulting in approximately 0.04 excess LCF; MEI dose at nearest public access (on Pajarito Road) approximately 46 rem; at most exposed residence approximately 4 rem.	NOA—baseline. No change in likelihood or severity among the alternatives.
RAD-02	Plutonium release from the CMR Building due to natural gas pipe-line break, gas ingestion into facility, and subsequent explosion and fire.	Negligible likelihood, $< 10^{-6}$ per year or $> 1,000,000$ years between occurrences.	Mean population dose approximately 120,000 person-rem, resulting in approximately 57 excess LCFs; MEI dose at nearest public access (Diamond Road) approximately 4000 rem; at nearest residence approximately 170 rem.	NOA—baseline. No change in likelihood or severity among the alternatives.

TABLE G.5-1.—Summary of Consequences from Risk-Significant Accidents at LANL^a-Continued

SCENARIO	DESCRIPTION	BASILINE LIKELIHOOD ^b	BASILINE CONSEQUENCE MEASURES ^c	EFFECT OF ALTERNATIVES ^d
RAD-03	Highly enriched uranium release from power excursion accident with Godiva-IV outside Kiva #3.	Approximately 3.4×10^{-6} per year (i.e., one event in 300,000 years).	Mean population dose approximately 110 person-rem, resulting in approximately 0.06 excess LCF; MEI dose at nearest public access (Pajarito Road) approximately 150 rem; at nearest habitation approximately 0.5 rem.	NOA—baseline. EXP—approximately 25% more likely. RED and GRN—no change in likelihood. No change in severity among the alternatives.
RAD-04 ^f	Inadvertent detonation of plutonium-containing assembly at DARHT firing point.	Negligible likelihood, $< 10^{-6}$ per year or $> 1,000,000$ years between occurrences.	Mean population dose approximately 9,000 person-rem, resulting in approximately 5 excess LCFs; MEI dose for nearest public access (State Route 4) approximately 76 rem.	NOA—baseline. No change in likelihood or severity among the alternatives.
RAD-05	Tritium oxide release due to aircraft crash at TSFF.	5.3×10^{-6} per year (i.e., one accident in 190,000 years).	Mean population dose approximately 24 person-rem; 0.012 excess LCF or negligible chance of excess LCF. MEI approximately 0.01 rem. ^g	NOA—baseline. The same for all alternatives, except with RED, the tritium available for release is reduced by 25% in one but not both buildings.
RAD-06	Plutonium release due to aircraft crash at RAMROD.	Negligible likelihood, $< 10^{-6}$ per year or $> 1,000,000$ years between occurrences.	Mean population dose approximately 7,900 person-rem, resulting in approximately 4 excess LCFs.	NOA—baseline. No change among alternatives.
RAD-07	Plutonium release from WCRRF transuranic waste container storage area fire.	1.5×10^{-4} per year (i.e., one in 7,000 years).	Mean population dose approximately 1,300 person-rem, resulting in approximately 0.7 excess LCF; MEI dose at closest public access (Pajarito Road) approximately 74 rem; at closest habitation approximately 4 rem.	NOA—baseline. EXP—likelihood doubles due to higher waste throughput. RED—likelihood reduced by 25%. GRN—same as baseline; no change in severity.
RAD-08	Plutonium release from TWISP transuranic waste storage domes due to aircraft crash and fire.	4.3×10^{-6} per year (i.e., one event in approximately 200,000 years).	Mean population dose approximately 400 person-rem, resulting in approximately 0.2 excess LCF; MEI dose at nearest public access (Pajarito Road and nearest border with White Rock) 22 rem.	NOA—baseline. No effect of alternatives on crash likelihood or maximum waste loading assumed in the analysis.

TABLE G.5-1.—Summary of Consequences from Risk-Significant Accidents at LANL^a-Continued

SCENARIO	DESCRIPTION	BASELINE LIKELIHOOD ^b	BASELINE CONSEQUENCE MEASURES ^c	EFFECT OF ALTERNATIVES ^d
RAD-09	Plutonium release due to transuranic waste drum failure or puncture (for high and typical activity in drum).	4.1×10^{-3} per year (i.e., one in approximately 250 years for high-activity drum); 0.4 per year (i.e., 1 in 2.5 years for typical-activity drum).	Mean population dose (high-activity drum) approximately 230 person-rem, 0.12 excess LCF. Mean population dose (typical-activity drum) approximately 4.3 person-rem, with 0.0022 excess LCF or negligible risk. MEI dose of 0.41 rem.	NOA—baseline. Number of drum operations, and thus likelihood, up 20% for EXP; down 5% for RED. GRN—same as baseline.
RAD-10	Plutonium release from degraded storage container at plutonium facility.	$< 10^{-6}$ per year; negligible likelihood of external release (i.e., $< 10^{-6}$ per year).	For the incredible accident, mean population dose approximately 560 person-rem, with 0.28 excess LCF. MEI dose of approximately 44 rem at Pajarito Road boundary.	NOA—baseline. Alternatives do not alter the likelihood or severity of these accidents associated with the repackaging of stored plutonium.
RAD-11 ^f	Container breach after detonation of plutonium-containing assembly at DARHT firing point.	Negligible likelihood, $< 10^{-6}$ per year or $> 1,000,000$ years between occurrences.	Mean population dose approximately 210 person-rem, resulting in < 1 excess LCF; MEI dose (maximum dose point on State Route 4) approximately 14 rem.	NOA—baseline. Alternatives do not alter the likelihood or severity of such accidents.
RAD-12 ^f	Explosively driven dispersal of plutonium at TA-16-411.	1.5×10^{-6} per year or about 1 in 670,000 years.	Mean population dose approximately 35,800 person-rem; 18 excess LCFs. MEI (maximum dose at closest site boundary) 138 rem.	NOA—baseline. Alternatives do not alter the likelihood or severity of such accidents.
RAD-13	Plutonium release from flux trap irradiation experiment at TA-18.	1.6×10^{-5} per year (i.e., one event in 62,000 years).	Mean population dose approximately 160 person-rem, resulting in 0.08 excess LCF; MEI dose at closest public access (Pajarito Road) is approximately 120 rem; at closest habitation is approximately 0.12 rem.	NOA—baseline. Alternatives do not alter the likelihood or severity of such accidents.
RAD-14	Plutonium release from ion exchange column thermal excursion at Plutonium Facility.	$< 10^{-6}$ per year (i.e., < 1 in one million years).	Mean population dose approximately 130 person-rem (i.e., 0.063 excess LCF); MEI dose 0.45 rem at Pajarito Road and 0.32 rem at closest habitation.	NOA—baseline. Alternatives have no effect on likelihood or severity of such accidents.

TABLE G.5-1.—Summary of Consequences from Risk-Significant Accidents at LANL^a-Continued

SCENARIO	DESCRIPTION	BASELINE LIKELIHOOD ^b	BASELINE CONSEQUENCE MEASURES ^c	EFFECT OF ALTERNATIVES ^d
RAD-15	Plutonium release from the ARIES process: (1) Hydride-dehydride glovebox fire. (2) Plutonium release from wing fire.	(1) 3.6×10^{-5} per year (2) 3.2×10^{-5} (i.e., 1 in about 30,000 years for both accident scenarios).	(1) Mean population dose 4.5 person-rem; approximately 0.0023 excess LCFs; MEI at closest public access: approximately 4.1 rem. (2) Mean population dose approximately 1,700 person-rem; approximately 0.85 excess LCFs; MEI at closest public access: approximately 91 rem.	NOA—baseline. EXP— (1) Increases the severity of the accident by approximately 4 times that of the NOA. (2) Increases the severity of the accident by approximately 100% over the NOA. RED and GRN—remain the same as the NOA. Frequencies remain the same across alternatives.
RAD-16 ^g	Plutonium release due to aircraft crash at the CMR Building.	Approximately 3.5×10^{-6} per year (i.e., one event in approximately 300,000 years).	Mean population dose: approximately 56 person-rem; 0.03 excess LCFs expected; MEI dose at closest public access approximately 3 rem; at nearest habitation approximately 0.03 rem.	NOA—baseline. Alternatives do not alter the likelihood or severity of such accidents.
WORK-01	Inadvertent detonation of high explosives.	10^{-3} to 10^{-2} per year (i.e., one in approximately 100 to 1,000 years).	1 to 10 fatalities or injuries.	NOA—baseline. EXP—50% increase in likelihood. RED—20% reduction in likelihood. GRN—40% reduction in likelihood.
WORK-02	Biohazard contamination of a single worker.	10^{-2} to 10^{-1} per year (i.e., one in approximately 10 to 100 years).	One casualty.	NOA—baseline. No differences among alternatives apart from the addition of one more pathogen in EXP.
WORK-03	Inadvertent criticality event at the CMR Building, Critical Experiments Facility, or Plutonium Facility.	$< 10^{-5}$ per year (i.e., one in more than 100,000 years).	Substantial doses to those few workers in the immediate vicinity, with possible fatalities from acute exposures.	NOA—baseline. Alternatives have little effect on likelihood and none on severity of such accidents.
WORK-04	Inadvertent exposure of workers to electromagnetic radiation.	10^{-2} to 10^{-1} per year (i.e., one in approximately 10 to 100 years).	Typically one, rarely several, casualties.	NOA—baseline. Alternatives have little effect on likelihood and none on severity of such accidents.

TABLE G.5–1.—Summary of Consequences from Risk-Significant Accidents at LANL^a-Continued

SCENARIO	DESCRIPTION	BASELINE LIKELIHOOD ^b	BASELINE CONSEQUENCE MEASURES ^c	EFFECT OF ALTERNATIVES ^d
WORK-05	Plutonium release from degraded storage container at Plutonium Facility	0.23 per year (i.e., one in approximately 5 years).	Significant but nonlethal doses to one to two operators.	NOA—baseline. Alternative have little effect on likelihood and none on severity of such accidents.

^a See the individual narratives for each accident in section G.5 for additional information.

^b Accident likelihood estimates are conservative, given the information available. However, for the particularly unlikely accidents, it is possible that there are causal mechanisms that were missed; therefore, the possibility of a more probable scenario cannot be rigorously ruled out. The frequency per year is more correctly described as the probability of occurrence in any 12-month period. See detailed explanation under Meaning of Risk and Frequency in section G.1.

^c Conservative assumptions have been employed in estimating the quantity and form of the hazardous materials available for release. Accident consequences are generally conservative (pessimistic) but do not bound the effects of accidents occurring under unusually unfavorable weather conditions. The results quoted for radiological accidents are weather-averaged. MEIs for each location are hypothetical individuals who do not leave and do not take protective actions to avoid exposure. Excess LCFs are cancers resulting from, and that develop well after, exposure to ionizing radiation. The excess LCF is the product of the dose and the risk factor of 5×10^{-4} excess LCF/person-rem. This is discussed in the primer on the effects of radiation in section D.1 of appendix D, Human Health.

^d Explanations of the alternatives: No Action (NOA), Expanded Operations (EXP), Reduced Operations (RED), and Greener (GRN) appear in the introduction to this appendix and in chapter 3. The baseline risk is the risk from current operations, plus planned activities. Together, these constitute the NOA. There is frequently no difference among the alternatives in accident frequency and public consequence. The inventories used in the analyses are typically those of bounding permitted or administrative limits, rather than realistic values that would be more likely to change among the alternatives. The accident frequencies depend upon the accident initiators, many of which are independent of the operations and of inventory, and therefore, do not change among alternatives. Frequencies that depend upon operations, such as the number of drums being processed, do not necessarily translate into change in frequency of an environmental release, but may affect the frequency of worker accidents.

^e As with other plutonium doses, these 4,000 rem are the total dose that accumulates over a 50-year lifetime as a result of the initial intake.

^f These accidents are taken from the DARHT EIS (DOE 1995a) and utilize different modeling from the others shown in this table; therefore, the results may not be strictly comparable. For example, the integrated exposures for these accidents do not include exposures to on-site workers. The DARHT EIS treated the on-site workers as noninvolved workers. The doses were given as an individual dose and not included in the integrated population numbers. For this reason, integrated population doses in this EIS are higher than those in the DARHT EIS; however, both EISs assessed the consequences to noninvolved workers. See text under each accident for elaboration.

^g This is at 360-meter distance. The closest public access would likely be involved in the crash.

**TABLE G.5.1-1.—Summary of Consequences to Workers at
Accident Origination Facilities**

SCENARIO	DESCRIPTION	FACILITY WORKER CONSEQUENCES
SITE-01	Moderate earthquake on the Pajarito Fault or a large earthquake in the Rio Grande Rift zone, resulting in structural damage and/or severe internal damage to comparatively low-capacity facilities.	Workers in buildings that are structurally damaged or that suffer partial or total collapse (unusual, but possible) could be injured or killed. Worldwide experience with very severe earthquakes indicates that <i>a priori</i> predictions of the numbers of injuries and fatalities are not possible. The experience <u>clearly</u> indicates that large numbers of fatalities (i.e., many hundreds to thousands of deaths) are not commonly experienced except under special conditions. These special conditions include severe earthquakes with large numbers of people in severely substandard structures that suffer complete collapse. Modern structures do not often experience such failures, even in very severe earthquakes. Other circumstances under which large numbers of fatalities can occur include seismically induced, widespread fires. Other impacts to workers can include delayed emergency response (including medical assistance) and indirect effects from releases of hazardous materials (both inside facilities and to the environment).
SITE-02	Large earthquake on the Pajarito Fault, resulting in structural damage and/or severe internal damage to comparatively moderate-capacity facilities.	See SITE-01.
SITE-03	Very large earthquake on the Pajarito Fault and perhaps the Embudo Fault, resulting in structural damage to essentially all facilities.	See SITE-01.
SITE-04	Site-wide wildfire consuming combustible structures and vegetation.	All threatened workers would be evacuated prior to arrival of the fire front. Aircraft crashes have occurred while dropping slurry on wildfires. Firefighters are at risk if they enter an area without an alternate escape route, and there have been historical fatalities from such events. However, because life safety is given first priority over protection of property at LANL, it is not likely that there will be worker fatalities. Some firefighters and other emergency personnel are likely to have significant but transient effects from smoke inhalation.
CHEM-01	Chlorine release (up to 150 pounds) from potable water treatment station due to human error during cylinder changeout or maintenance, or due to random hardware failures.	For the cylinder rupture event, it is unlikely that workers will be present because due to the nature of the event, it is assumed to occur at random rather than as a result of worker activity. Even with very prompt response by workers inside the building when the release occurs, severe injury or fatality is possible with large chlorine leak rates. The number of injuries and fatalities depends on the exact number and location of workers at the facility at the time of the event. For small leak rates, the likelihood of injury or death is low due to the self-annunciating nature of the event.

**TABLE G.5.1-1.—Summary of Consequences to Workers at
Accident Origination Facilities-Continued**

SCENARIO	DESCRIPTION	FACILITY WORKER CONSEQUENCES
CHEM-02	Multiple-cylinder release (1,500 pounds) from toxic gas storage shed at Gas Plant due to fire or aircraft crash.	Workers present at the Gas Plant (TA-3-170 and environs) can be injured or killed, depending upon wind direction and wind speed. However, the chlorine gas and fire causing the release will be readily visible, and escape from the plume, even on foot, is likely. Workers attempting to fight the fire without personal protective equipment can be overcome by chlorine gas.
CHEM-03	Chlorine release (150 pounds) from toxic gas storage shed at Gas Plant due to random cylinder failure or multiple human errors during cylinder handling.	Gas Plant workers who are directly involved in handling the cylinders of chlorine can be exposed to ERPG-2 or ERPG-3 concentrations from the human error contributor to this event. In the case of random failures, it is unlikely that workers will be in the immediate vicinity of the cylinder. Gas Plant workers can be exposed to high concentrations of chlorine if located outdoors; but these employees will be able to evacuate the area rapidly, which would tend to reduce exposure consequences.
CHEM-04	Bounding single-cylinder release of toxic gas (selenium hexafluoride) from waste cylinder storage.	There are typically four or five employees in the area during normal work hours. Injuries or fatalities can occur due to exposures as well as missiles from cylinder rupture. Workers are trained to leave the area in the event of a gas release. Consequences will depend on wind speed and direction.
CHEM-05	Bounding multiple-cylinder release of toxic gas (sulfur dioxide) from waste cylinder storage.	See CHEM-04.
CHEM-06	Chlorine release outside Plutonium Facility.	Air intakes at TA-55-4 are on the west end of the building, about 18 feet (5 meters) above the ground, and the chlorine release location is on the north side of the building at ground level. In addition, there is an isolation valve in the intake ductwork. Thus, it is unlikely that chlorine will be drawn into the building. Personnel located outdoors can be exposed to ERPG-2 and ERPG-3 concentrations of chlorine; but these employees will be able to evacuate the area rapidly, which would tend to reduce exposure consequences.
RAD-01	Plutonium release from RANT Facility transuranic waste container storage area fire.	There are about a dozen employees at the facility during day shift who can be at risk of plutonium inhalation as a result of this fire. However, the employees would be expected to take shelter or evacuate the area, which would reduce exposures. No lethal exposures would be expected.
RAD-02	Plutonium release from the CMR Building due to natural gas pipeline break, gas ingestion into facility, and subsequent explosion and fire.	Workers in the wing affected by the explosion can be severely injured or killed due to the dynamics of the explosion and the subsequent fire. Workers not directly affected by the explosion can inhale airborne plutonium that results from the explosion and subsequent fire. Contaminated air can be drawn into the building and dispersed to otherwise unaffected wings of the building.

**TABLE G.5.1-1.—Summary of Consequences to Workers at
Accident Origination Facilities-Continued**

SCENARIO	DESCRIPTION	FACILITY WORKER CONSEQUENCES
RAD-03	Highly enriched uranium release from power excursion accident with Godiva-IV outside Kiva #3.	Personnel will not be located outdoors during an experiment leading to this accident. The TA-18 control building provides 40% attenuation of gamma radiation; ventilation systems will be secured in the event of an accident, minimizing the air exchange rate with the outdoors. No acute fatalities are expected for this accident.
RAD-04	Inadvertent detonation of plutonium-containing assembly at DARHT firing point.	Up to 15 fatalities can occur among workers directly affected by blast effects. Other workers farther away can be injured and/or exposed to airborne radioactivity (the latter depends on wind speed and direction and the location of the workers). Workers not directly affected by the blast could receive nonlethal exposures of up to 160 rem at 1,300 feet (400 meters) and up to 90 rem at 2,430 feet (750 meters).
RAD-05	Tritium oxide release due to aircraft crash at TSFF or TSTA.	An aircraft crash into the building can result in severe injuries or deaths to nearly all the occupants of the building. Nearby workers not within the facility can also be injured or killed as a result of the crash dynamics, explosion, fire, missiles, etc. Workers not directly affected by the aircraft crash can be exposed to tritium oxide, but the release plume will be elevated and may skip over the immediate crash site before returning to the ground at some distance.
RAD-06	Plutonium release due to aircraft crash at RAMROD.	An aircraft crash into the building can result in severe injuries or deaths to nearly all the occupants of the building. Nearby workers not within the facility can also be injured or killed as a result of the crash dynamics, explosion, fire, missiles, etc. Workers not directly affected by the aircraft crash could be exposed to plutonium, but the release plume will be elevated and may skip over the immediate crash site before returning to the ground at some distance. (Note that this scenario was found, after detailed analysis, to screen on a frequency less than 1×10^{-7} per year.)
RAD-07	Plutonium release from WCRRF transuranic waste container storage area fire.	There are typically five WCRRF workers present during normal operations. The postulated accident will not result in an immediate release, providing time for implementation of evacuation or other protective measures. No fatal exposures are expected.
RAD-08	Plutonium release from TWISP transuranic waste storage domes due to aircraft crash and fire.	A small number of workers may be present during normal operations and can be directly affected by crash dynamics, explosion, fire, missiles, etc. Workers not directly affected by the aircraft crash can be exposed to plutonium, but the release plume will be elevated and may skip over the immediate crash site before returning to the ground at some distance.

**TABLE G.5.1-1.—Summary of Consequences to Workers at
Accident Origination Facilities-Continued**

SCENARIO	DESCRIPTION	FACILITY WORKER CONSEQUENCES
RAD-09	Plutonium release due to transuranic waste drum failure or puncture.	The accident results in an immediate dispersal of plutonium to the area where the work is being performed. The dose to the worker will be dependent on ambient conditions and the speed with which protective actions can be taken (e.g., evacuation). No acute fatalities are expected for this accident.
RAD-10	Plutonium release from degraded storage container at Plutonium Facility.	The workers present when a container fails could be exposed to plutonium inhalation with substantial doses possible, depending upon the usage of PPE and the speed with which workers exit the immediate area.
RAD-11	Container breach after detonation of plutonium-containing assembly at DARHT firing point.	No fatalities are expected for the containment failure event because workers will be inside the facility and protected from material releases. Workers not directly involved with the experiment can receive nonlethal doses of up to 60 rem at 1,300 feet (400 meters) and up to 20 rem at 2,460 feet (1,750 meters).
RAD-12	Plutonium release from seismically initiated event at TA-16-411.	Workers within the facility would be killed by the explosion and building collapse.
RAD-13	Plutonium release from flux trap irradiation experiment at TA-18.	See RAD-03.
RAD-14	Plutonium release from ion exchange column thermal excursion at Plutonium Facility.	Workers in the room where the event occurs can be injured or killed due to the dynamics of the accident. Plutonium particulate inhalation is also possible. No fatalities have occurred in past resin thermal excursion events at other facilities.
RAD-15	Plutonium release from hydride-dehydride glovebox fire.	From one to three workers may be present attending the operations. These workers can be killed or injured due to the direct effects of a laboratory fire or can be exposed to plutonium particulates via inhalation. Other workers can be affected by smoke inhalation. Workers outside the facility will not be expected to be impacted due to redundant trains of HEPA filtration between the accident location and the outside environment.
RAD-16	Plutonium release due to aircraft crash at the CMR Building.	An aircraft crash into the CMR Building can result in severe injuries or deaths to nearly all the occupants of the building. Nearby workers not within the facility can also be injured or killed as a result of the crash dynamics, explosion, fire, missiles, etc. Workers not directly affected by the aircraft crash can be exposed to plutonium, but the release plume will be elevated and may skip over the immediate crash site before returning to the ground at some distance.
WORK-01	Inadvertent detonation of high explosives.	One to several workers can be killed due to explosion dynamics. The actual number of workers depends on the circumstances of the explosion (e.g., type of activity in progress, quantity of explosives involved, distances of workers from explosion site, etc.).

**TABLE G.5.1-1.—Summary of Consequences to Workers at
Accident Origination Facilities-Continued**

SCENARIO	DESCRIPTION	FACILITY WORKER CONSEQUENCES
WORK-02	Biohazard contamination of a single worker.	One worker can be contaminated by this accident. The outcome of the contamination depends on the nature of the agent involved and the extent and efficacy of medical intervention. Fatality is possible but not likely, based on experience in the medical and research communities.
WORK-03	Inadvertent criticality event at the CMR Building, Critical Experiments Facility, or Plutonium Facility.	One or more workers can be killed due to acute radiation exposure, but the lethal zone is limited to tens of meters from the site of the criticality event. Other workers can receive sublethal exposures or can inhale fission products.
WORK-04	Inadvertent exposure of workers to electromagnetic radiation.	Severe injury or death is possible in the worst case. Sublethal effects (e.g., eye injuries) are also possible.
WORK-05	Plutonium release from degraded storage container at Plutonium Facility.	The workers handling the container can be exposed to plutonium particulates by inhalation. Significant but nonlethal doses are possible depending on the usage of personal protective equipment and the speed with which the workers exit the immediate area.

G.5.3 Note on the Consequences from Earthquakes

For the site-wide earthquakes, the earthquake frequency, the MAR (dominant contributors), and accident consequences across the alternatives are also projected to be comparable.

G.5.4 Site-Wide Earthquake and Wildfire Accidents

LANL is located within the Rio Grande Rift, a tectonically active province in the western U.S. Although only six historic earthquakes of Richter magnitude (ML) of 5.0 or greater have occurred in the LANL region, the period of historical observation is short (from about 1850 for events of ML 5.5) (Wong et al. 1995). Although no surface faulting has occurred in historic times, detailed paleoseismic investigations have found evidence of surface faulting in prehistoric times. Seismic studies currently in progress have further evaluated the potential for ground faulting. These studies indicate the possibility of such events is low, but credible, at some locations on the LANL site. Section 4.2.2.2 (in volume I, chapter 4) and appendix I further discuss the recently completed studies and their implication to DOE and LANL.

In order to evaluate the seismic hazards at LANL more fully, and in accordance with the guidance contained in DOE Standards 1020 and 1023 (DOE 1994e and DOE 1995b), LANL contracted with Woodward-Clyde Federal Services to perform a state-of-the-art PSHA. PSHA provides estimates of the frequency of various levels of ground movement (e.g., peak horizontal ground acceleration [PGA], represented in terms of the multiple of the force of gravity, represented by the letter “g”). The analysis evaluated the contribution of 25 faults to the seismic hazard at LANL, accounting for all known faults within 93 miles (150 kilometers) of the site that could produce ground accelerations of 0.05 g or greater (e.g., a

PGA of 0.05 g is representative of the onset of strong ground shaking) (Wong et al. 1995). In addition, areal seismic sources were considered in an attempt to account for hidden faults that could produce earthquakes of up to magnitude 6.5 (larger faults would produce surface ruptures that would be represented already).

The Woodward-Clyde analysis found that most of the seismic hazard at LANL is due to projected seismic activity in the Rio Grande Rift and along the Pajarito, Rendija Canyon, Guaje, Sawyer Canyon, and Embudo faults. The surface expression of the Pajarito fault runs along the western boundary of LANL. The fault, which is a down-to-the-east fault, underlies the entire laboratory; all significant facilities at LANL are within 3.5 miles (5.6 kilometers) of the surface expression of the fault. The two facilities with the largest radiological hazard potential at LANL are the CMR Building and TA-55-4 facility, which are 0.4 and 1.9 miles (0.7 and 3.1 kilometers), respectively, from the surface expression of the Pajarito Fault. Therefore, the structures at LANL are considered to be near-field for the purposes of an earthquake along the Pajarito Fault. This near-field status means that large vertical displacements could occur in an earthquake along the Pajarito Fault, along with the horizontal displacements. Modeling performed by Woodward-Clyde indicates that vertical accelerations could exceed the horizontal acceleration at near-source distances of up to 6 miles (10 kilometers).

PSHA for Los Alamos indicates that the frequency of a very large peak horizontal ground acceleration (1.0 g) is approximately one in one hundred thousand per year, or 1.0×10^{-5} per year. Because the most structurally robust facility at LANL has a design basis earthquake of 0.31 g, it is clear that earthquakes have a potential to cause significant damage to LANL facilities.

The risks posed by earthquakes at LANL have been assessed on a site-wide basis, unlike

existing safety documentation, which considers the facilities independently. The seismic analysis herein is based on PSHA, on available safety documentation (which in many cases provides information on the seismic capacity of important structures), on facility walkdowns conducted by the SWEIS accident analysts, and on engineering judgment. The approach taken in the analysis was to estimate conservative structural failure thresholds (referred to as HCLPF values), which correspond roughly to a high confidence that the conditional probability of structural failure is 5 percent or less at a given ground acceleration. By estimating conservative HCLPF values, the frequency of failure can be established with greater confidence than if the median or mean fragility values were estimated using limited resources. This approach places most of the uncertainty in failure frequency on the down side of the risk estimates; that is, it is much more likely that the actual failure frequency is lower than the estimated value than it is higher. Still, with a consistent approach to the analysis, the relative ranking of seismically initiated failures should be valid.

Once the HCLPF values are estimated (these values are tabulated in Table G.5.4-1), the seismic hazard information can be convolved with the HCLPF values to calculate the failure frequency. Because the seismic hazard is not very different among the eight LANL sites analyzed, the seismic hazard from TA-55 was used in quantification. The frequency of failure corresponding to HCLPF values for TA-55 is presented in Table G.5.4-2. Using the information in Tables G.5.4-1 and G.5.4-2, seismic failure events and their corresponding frequencies of occurrence were estimated as set forth in Table G.5.4-3.

In principle, if the assessment of seismically initiated accidents was being done as part of a full-scope PRA, the frequency of structural failure (or internal component/system damage) could be calculated uniquely for each structure and risks calculated separately for each

resulting chemical or radiological release. However, the SWEIS accident analysis is not a seismic PRA. The goal of the analysis is to identify for the decision maker and stakeholders the risks associated with the SWEIS alternatives and to evaluate whether there are any significant differences in accident risks across the alternatives. Examining the results of the analysis in Table G.5.4-3, and considering the approximate method by which the HCLPF values were assigned, the uncertainties in the results are such that grouping the failure events by frequencies within a factor of three or four of one another is not unreasonable. Based on Table G.5.4-3, three site-wide earthquakes were identified, as listed in Table G.5.4-4. In addition, the potential impact of ground faulting at one facility of concern, the CMR Building, will be discussed as a subsection of the SITE-03 event.

Appendix I summarizes the ongoing and recently completed seismic hazard studies, as well as the implications of these studies for DOE and LANL. The uncertainties in the estimated seismic risk are large. The seismic hazard estimate alone has significant uncertainties. To illustrate, the uncertainties in the seismic hazard are such that the 5th to 95th percentile horizontal PGA values at a frequency of 1×10^{-5} per year range from about 0.55 g to much greater than 1.0 g. Similarly, the 5th to 95th percentile frequency values, for a horizontal PGA of 1.0 g, spans the range from 5×10^{-5} to much less than 1×10^{-6} per year.

G.5.4.1 ***SITE-01, Site-Wide Earthquake Causing Damage to Low-Capacity Structures/Internals***

Consequences of SITE-01 for Facility Workers and the Public

The consequences of SITE-01 are presented separately for workers and the public. For

TABLE G.5.4-1.—Estimated High Confidence in Low Probability of Failure Capacities of LANL Structures and Internals

FACILITY DESIGNATION	FAILURE HCLPF ^a	NOTES
TA-00-1109	0.04	Unreinforced concrete block structure; large-diameter natural gas pipeline and pumping station located within 50 feet of this structure; a small-diameter natural gas pipe also enters the structure; HCLPF based on judgment and Campbell et al. 1988.
TA-00-1110	0.04	Unreinforced concrete block structure; two large water tanks located within 100 feet of this structure; HCLPF based on judgment and Campbell et al. 1988.
TA-3 Admin. Complex	0.04	0.15 g PGA calculated as having a high probability of failure (Miller et al. 1995); also consistent with LANL 1991a.
TA-3-29 (CMR)	0.08	The CMR Building expected to fail at 0.17 g median fragility (LANL 1995c), corresponding to a HCLPF of 0.08 g. The basement vault is expected to survive intact, but may suffer damage and leakage at earthquake magnitudes comparable to a HCLPF of 0.34 g (frequency of 7.1×10^{-5} /yr.).
TA-3-66 (Sigma)	0.05	Built in late 1950's; HCLPF based on LANL 1991a (original seismic design for 0.05 g) and PC 1996b (3 of 4 building sectors fail Federal Emergency Management Agency [FEMA] 178 life safety requirements corresponding to 0.14 g PGA).
TA-3-476	0.25	Judgmental estimate for overturning the shed in an earthquake.
TA-9-21	0.04	Judgmental estimate based on facility walkdown.
TA-15 DARHT	NA	No credible accident scenarios were identified wherein a seismic event could trigger a release from DARHT that would have any off-site impacts (DOE 1995a). If an earthquake were to occur with an assembly loaded and the containment sealed, not only would the container supports have to fail, but the explosives in the assembly would have to detonate and the containment would have to fail in order for a release to the environment to occur. The congruence of a sufficiently large earthquake, the conditional probability of an assembly being installed in the containment, the explosives detonating, and the containment structurally failing are considered to be incredible.
TA-16-205 (WETF)	0.14	Corresponds to 5×10^{-4} /yr frequency estimate in SAR based on Table G.5.1-2; this earthquake does not cause structural failure (LANL 1996e), but results in a tritium release due to failures internal to the facility coupled with failure of the ventilation isolation system (100 grams tritium oxide; 250 grams in the Expanded Operations Alternative).
	0.30	SAR estimates structural failure at 0.6 g (LANL 1996e); however, the frequency in the SAR (1.5×10^{-5} /yr) corresponds to an HCLPF of about 0.53 g, for which the median fragility would be much higher than 0.6 g. Indeed, that SAR frequency corresponds to approximately a 1.0 g PGA earthquake; the value shown here is a judgment pending further evaluation. In addition, during drafting of this SWEIS, DOE was informed that a seismically related unidentified safety question is in progress for WETF, which may lower the structural failure fragility to 0.3 g.
TA-16-411	0.05	Built in early 1950's; HCLPF based on judgment and PC 1996b (fails FEMA 178 life safety requirements corresponding to 0.14 g PGA).

TABLE G.5.4-1.—Estimated High Confidence in Low Probability of Failure Capacities of LANL Structures and Internals-Continued

FACILITY DESIGNATION	FAILURE HCLPF ^a	NOTES
TA-18-23 (Kiva #1)	0.05	Built in late 1940's to UBC criteria; HCLPF based on judgment and PC 1996b (fails FEMA 178 life safety requirements corresponding to 0.14 g PGA). Also calculated to be incapable of surviving the design basis earthquake of 0.22 g (LANL 1996f).
TA-18-32 (Kiva #2)	0.22	Analyzed in the SAR using finite element analysis against University of California Research Laboratory (UCRL-15910) seismic criteria and found to survive the design basis earthquake for a Hazard Category 2 facility. Assuming facility is DOE Standard 1020-94 Performance Category 2, HCLPF judgmentally assigned at 0.22 g, which corresponds to the Performance Category 2 earthquake at TA-18 (Wong et al.1995).
TA-18-116 (Kiva #3)	0.22	See notes for TA-18-32, above.
TA-18-168 (SHEBA)	0.22	See notes for TA-18-32, above.
TA-21-155 (TSTA)	0.10	Built in early 1950's; SAR indicates 0.33 g median fragility (LANL 1996g), but PC 1996b indicates that both sectors of building fail the FEMA 178 life safety requirements, corresponding to 0.14 g PGA. Building brought up to 1976 UBC requirements for seismic and wind; but the upgrade was not meant to conform to UCRL-15910 or DOE Standard 1020 (LANL 1996g).
TA-21-209 (TSFF)	0.10	Built in late 1960's; HCLPF based on SAR (LANL 1996h) and PC 1996b (all three sectors failed FEMA 178 life safety requirements, corresponding to 0.14 g PGA).
TA-43-1 (HRL)	0.08	HCLPF based on LANL 1991a (capable of 0.18 g resistance); 5 of 6 sectors failed FEMA 178 life safety requirements, corresponding to 0.14 g PGA (PC 1996b).
TA-50-1 Radioactive Liquid Waste Treatment Facility (RLWTF)	0.10	SAR states that the facility cannot withstand the 0.22 g design basis earthquake for a Performance Category 2 facility (LANL 1995d); HCLPF assigned by judgment based on SAR-reported frequency of $1.4 \times 10^{-3}/\text{yr}$ (LANL 1995d).
TA-50-37 (RAMROD)	0.07	HCLPF assigned based on fragility of 0.15 g and corresponding frequency of $2 \times 10^{-3}/\text{yr}$ (LANL 1996i).
TA-50-69 (WCCR Facility)	0.22	HCLPF assigned based on design basis earthquake of 0.22 g (LANL 1995e).
TA-54 TRU Domes	0.11	HCLPF assigned based on design basis earthquake of 0.22 g with a corresponding frequency of $1 \times 10^{-3}/\text{yr}$ (LANL 1995f); corresponds to structural collapse of the tension dome structures of four domes and impact of 10% of the TRU waste drums on the top row of the stacks.
	0.31	HCLPF assigned based on beyond design basis earthquake of 0.57 g with a corresponding frequency of $1 \times 10^{-4}/\text{yr}$ (LANL 1995f); corresponds to dome failure plus overturning of 10% of the TRU waste drums.
TA-54-38 (RANT)	0.11	HCLPF assigned based on the SAR, which states that the facility was designed to withstand seismic Zone 2 earthquake loads and design live loads per UBC 1985, corresponding to a 0.11 g design basis earthquake. However, additional bracing (tying together the roof and walls to resist the 100-year wind) brings the seismic resistance to greater than 0.11 g but less than the required 0.22 g for the facility (LANL 1996j).

TABLE G.5.4-1.—Estimated High Confidence in Low Probability of Failure Capacities of LANL Structures and Internals-Continued

FACILITY DESIGNATION	FAILURE HCLPF ^a	NOTES
TA-55-4	0.14	Design basis earthquake; facility structure remains intact, but some process enclosures collapse due to anchorage failure resulting in a free-fall spill of MAR and the rupture of process gas lines. Ventilation system fails due to loss of off-site power and failure of nonsafety-class ductwork within the building. LPF = 6% due to ventilation system failure and pressurized gas-driven release; frequency of this scenario is 4×10^{-4} /yr (LANL 1996k). The release for this scenario, calculated on a spreadsheet basis, is estimated at 1.16×10^2 grams of heat source plutonium, 5.17 grams of weapons-grade plutonium, 0.201 grams of plutonium-242, and 0.241 grams of highly enriched uranium (LANL 1996k).
	0.23	Beyond evaluation basis earthquake included in the SAR; similar to 0.30 g in that the structure remains intact with an LPF = 0.06, but more gloveboxes, etc., fail, increasing the source term. Release, calculated on a spreadsheet basis, is estimated at 1.74×10^2 grams of heat source plutonium, 5.31 grams of weapons-grade plutonium, 0.201 grams of plutonium-242, and 0.242 grams of highly enriched uranium (LANL 1996k).
	0.44	Beyond design basis earthquake <u>not</u> included in the TA-55 SAR; the structure has an HCLPF of 0.44 g, corresponding to an annual frequency of 3.16×10^{-5} /yr (LANL 1996k).
TA-55-185	0.31	TA-55-185 is a prefabricated metal building located on a concrete pad; it is a general use facility constructed in accordance with the 1988 UBC (DOE 1996g). HCLPF assigned based on judgment considering design and considering TA-54 Area G analysis for toppling of top row of TRU drums (LANL 1995f).
TA-55-249	0.23	Based on beyond evaluation basis earthquake for TA-55-4 (see above).

^a Failure HCLPF is the ground acceleration where the probability of structural failure is 5% or less.

TABLE G.5.4-2.—HCLPF Values Versus Annual Frequency of Failure

HCLPF	FREQUENCY	HCLPF	FREQUENCY	HCLPF	FREQUENCY	HCLPF	FREQUENCY
0.01	9.93×10^{-3}	0.16	5.24×10^{-4}	0.31	1.01×10^{-4}	0.46	2.67×10^{-5}
0.02	8.59×10^{-3}	0.17	4.60×10^{-4}	0.32	9.18×10^{-5}	0.47	2.46×10^{-5}
0.03	6.38×10^{-3}	0.18	4.06×10^{-4}	0.33	8.36×10^{-5}	0.48	2.26×10^{-5}
0.04	4.67×10^{-3}	0.19	3.59×10^{-4}	0.34	7.62×10^{-5}	0.49	2.08×10^{-5}
0.05	3.54×10^{-3}	0.20	3.19×10^{-4}	0.35	6.95×10^{-5}	0.50	1.92×10^{-5}
0.06	2.78×10^{-3}	0.21	2.84×10^{-4}	0.36	6.35×10^{-5}	0.51	1.77×10^{-5}
0.07	2.24×10^{-3}	0.22	2.54×10^{-4}	0.37	5.80×10^{-5}	0.52	1.63×10^{-5}
0.08	1.84×10^{-3}	0.23	2.27×10^{-4}	0.38	5.31×10^{-5}	0.53	1.50×10^{-5}
0.09	1.53×10^{-3}	0.24	2.04×10^{-4}	0.39	4.86×10^{-5}	0.54	1.39×10^{-5}
0.10	1.29×10^{-3}	0.25	1.84×10^{-4}	0.40	4.45×10^{-5}	0.55	1.28×10^{-5}
0.11	1.09×10^{-3}	0.26	1.66×10^{-4}	0.41	4.08×10^{-5}	0.56	1.18×10^{-5}
0.12	9.29×10^{-4}	0.27	1.49×10^{-4}	0.42	3.74×10^{-5}	0.57	1.09×10^{-5}
0.13	7.99×10^{-4}	0.28	1.35×10^{-4}	0.43	3.44×10^{-5}	0.58	1.01×10^{-5}
0.14	6.90×10^{-4}	0.29	1.22×10^{-4}	0.44	3.16×10^{-5}	0.59	9.35×10^{-6}
0.15	6.00×10^{-4}	0.30	1.11×10^{-4}	0.45	2.90×10^{-5}	0.60	8.65×10^{-6}

TABLE G.5.4-3.—Seismic Failures and Failure Frequencies Arrayed in Descending Order

FREQUENCY	HCLPF	FACILITY AND FAILURE SCENARIO
4.7 x 10 ⁻³	0.04	Administration Building structural failure
	0.04	TA-00-1109 structural failure
	0.04	TA-00-1110 structural failure
	0.04	TA-9-21 structural failure
3.5 x 10 ⁻³	0.05	TA-3-66 (Sigma) structural failure
	0.05	TA-18-23 (Kiva #1) structural failure
	0.05	TA-16-411 structural failure
2.2 x 10 ⁻³	0.07	TA-50-37 (RAMROD) structural failure
1.8 x 10 ⁻³	0.08	TA-3-29 (CMR) structural failure
	0.08	TA-43-1 (HRL) structural failure
1.1 x 10 ⁻³	0.10	TA-21-155 (TSTA) structural failure
	0.10	TA-21-209 (TSFF) structural failure
	0.10	TA-50-1 (RLWTF) structural failure
	0.11	TA-54 TRU domes structural failure, no drum overturning
	0.11	TA-54-38 (RANT) structural failure
6.9 x 10 ⁻⁴	0.14	TA-16-205 internal failures, structure remains intact
	0.14	TA-55-4 (Plutonium Facility) internal failures, structure remains intact
2.5 x 10 ⁻⁴	0.22	TA-18-32 (Kiva #2) structural failure
		TA-18-116 (Kiva #3) structural failure
		TA-18-168 (SHEBA) structural failure
		TA-50-69 (WCRR Facility) structural failure
2.3 x 10 ⁻⁴	0.23	TA-55-4 (Plutonium Facility) internal failures, structure remains intact; nitric acid tank and berm structural failure
	0.23	TA-55-249 (hydrochloric acid tank and berm) structural failure
1.8 x 10 ⁻⁴	0.25	TA-3-476 overturning
1.1 x 10 ⁻⁴	0.30	TA-16-205 structural failure
1.0 x 10 ⁻⁴	0.31	TA-54 TRU domes structural failure, drums overturning
	0.31	TA-55-185 structural failure
3.2 x 10 ⁻⁵	0.44	TA-55-4 (Plutonium Facility) structural failure

TABLE G.5.4-4.—Identified Site-Wide Earthquakes^a

FREQUENCY RANGE/YR	POINT ESTIMATE FREQUENCY	CHARACTERIZATION OF EARTHQUAKE
SITE-01 1.1 x 10 ⁻³ to 4.7 x 10 ⁻³	2.9 x 10 ⁻³	Low capacity structures or internals fail
SITE-02 1.8 x 10 ⁻⁴ to 6.9 x 10 ⁻⁴	4.4 x 10 ⁻⁴	Moderate capacity structures or internals fail
SITE-03 3.2 x 10 ⁻⁵ to 1.1 x 10 ⁻⁴	7.1 x 10 ⁻⁵	Comparatively high capacity structures fail

^a Based on the information provided in Table G.5.1-3.

workers, the following consequences are identified:

- Any time a facility occupied by workers is subjected to structural damage or collapse in an earthquake, injuries will occur and the potential for fatalities is also present. Worldwide experience with very severe earthquakes indicates that *a priori* predictions of the numbers of injuries and fatalities are not possible. The experience clearly indicates that large numbers of fatalities (i.e., many hundreds to thousands of deaths) are not commonly experienced except under special conditions. These special conditions include severe earthquakes with large numbers of people in severely substandard structures that suffer complete collapse. Modern structures do not often experience such failures, even in very severe earthquakes. Other circumstances under which large numbers of fatalities occur include seismically induced dam failures and seismically induced, widespread fires.
- Workers trapped in nonhazardous buildings could be exposed to radioactivity and chemicals released into the atmosphere as a result of structural damage to other facilities and fires.
- Medical assistance to injured workers could be delayed due to limited availability of immediate medical response resources as

well as by damage to transportation routes (e.g., due to landslides or collapsed bridges).

- These same considerations also apply to the off-site public.

Under the SITE-01 earthquake scenario, LANL nuclear facilities, except for the CMR Building, and most of LANL nonnuclear facilities would not collapse. The general effect is the potential to spill, create a small fire, or otherwise cause limited damage to material. Material that is “in process” is more likely to experience this type of effect. As a conservative value, the wing or building limits have been used as the MAR in these accidents with all of this material subject to spills, free-fall impacts, and a limited amount involved in fires. Bounding values were used in determining the amount of this material that had the potential for airborne transport. If internal systems could be damaged, the LPF for the facility was assumed to be 1.0. (That is, given the occurrence of the earthquake, it is assumed that the facilities that would experience structural or systems damage would always do so in a manner that creates an unconstrained path for material release outside of the structure.) This is a very conservative assumption because such damage could also occur in a manner that does not result in the release of material outside of the structure. (For example, walls might crack, but material storage containers could remain intact, or only

spill material within the structure.) For buildings that would not sustain internal structural or systems damage, the LPF was assumed to be zero.

As a specific example, in evaluating the impact of hypothesized building damage from a SITE-01 earthquake affecting the CMR Building, it was assumed that the full amount of the MAR (the wing limits) were in powder form, uncontained and unprotected, subject to impacts and spills from the earthquake ground motion and falling objects. All of this material was assumed to be freely available for dispersal to the outside following the building damage. For comparison, generally only about 40 percent of the material in the CMR Building is in powder form, the remainder being in metal or solution, and most of the materials are in storage containers during routine operations (most is not "in process"). Such storage containers would have to be breached in the course of or following the earthquake to make that material available for release. Thus, while there is a variety of scenarios that could be developed for the events resulting from such an earthquake, this approach represents a conservative case for the purposes of NEPA.

LANL nuclear facilities do meet the requirements for design basis earthquakes. This includes engineered controls to minimize the damage to internal structures and systems. However, for the purposes of NEPA, the seismic hazard is treated very conservatively. This approach is taken in recognition that the frequency and magnitude of earthquakes are uncertain. The uncertainty will remain until much more is known and understood about the causes of earthquakes and their effects, including the predictability of earthquake magnitudes for a given area. Far less uncertain is the response of buildings to given forces; however, the process for determining the exact values for building responses is both expensive and time consuming. For the purposes of this SWEIS and consistent with the requirements of NEPA, the analyses considered conservative

values for both the amount of material that could be affected in these scenarios and the ability for facilities and their systems to contain hazardous material.

Based on the foregoing discussion and analysis, low capacity structures/internals subject to damage and resulting in radiological releases for a 2.9×10^{-3} annual frequency earthquake include TA-3-29 (CMR Building structural collapse), TA-18-23 (Kiva #1 structural failure), TA-21-155 (TSTA Facility structural failure), TA-21-209 (Tritium Science and Fabrication Facility structural failure), TA-50-1 (RLWTF structural failure), TA-50-37 (Radioactive Materials Research, Operations, and Demonstration Facility structural failure), TA-54 Area G (TWISP Storage Dome failure), and TA-54-38 (Nondestructive Assay and Nondestructive Examination Facility structural failure). The dominant MAR and source terms are associated with TA-3-29, TA-50-1, TA-50-37, TA-54 Area G, and TA-54-38. Note that facilities that pose small additional risk were not included in the analyses. An example is TA-16-411, where the MAR is in a very strong part of the structure (vault) and is there only part of the time, so that a release from this facility as a result of an earthquake is believed to border on the incredible. The probability of such a release is discussed in detail under section G.5.6.12, RAD-12.

Note that these analyses (SITE-01, SITE-02, and SITE-03) do not attempt to evaluate the effect upon the population from the earthquake itself. Certainly, an earthquake in the Los Alamos area would have broader implications upon the local community than just the damage to LANL facilities. The population effects discussed here would only be incremental to the significant damage sustained from the earthquake itself.

The mean collective population dose from the dominant source term contributors is projected to total about 27,726 person-rem total effective

dose equivalent (TEDE), resulting in approximately 16 excess LCFs. Some 97 percent of the exposure rises from the CMR Building (TA-3-29), RAMROD (TA-50-37), and the RLWTF (TA-50-1). No acute (immediate) fatalities from radiation are expected to result from the earthquake event.

Doses to the MEI member of the public from the subject facilities will generally not be additive because of the diverse locations of the facilities and the attendant requirement that different wind directions at each facility converging on the MEI would be necessary to obtain concurrent exposures (not physically possible). MEI doses for community residents and the corresponding release sources are summarized as follows: (1) 20.2 rem (TEDE), Los Alamos townsite resident (TA-3-29); (2) 20.1 rem (TEDE), Royal Crest Trailer Park resident (TA-3-29, TA-50-1, TA-50-37); and (3) 3.0 rem (TEDE), White Rock resident (TA-54 Area G).

Chemical release consequences also have been calculated. Chemical releases include 300 pounds of chlorine released from TA-00-1109 and TA-00-1110, 7.6 liters of hydrogen cyanide produced by collapse of the floor at the Sigma facility (TA-3-66), 3 pounds of phosgene released from collapse of TA-9-21 (a laboratory building), and 30 liters of formaldehyde released from the Health Research Laboratory (TA-43-1). The consequences of these releases are described below (note that no emergency response actions are assumed, with exposure assessed as though the people exposed are located outdoors; both assumptions are conservative).

- *TA-00-1109 and TA-00-1110, 300 pounds chlorine released at each.* In both cases, the most likely outcome would be that the higher concentrations of chlorine (being a heavy gas) would proceed down into nearby canyons, and exposures to the public would be reduced. Under typical meteorological conditions, and assuming

flat terrain for the sake of conservatism, the ERPG-3 concentration of 20 parts per million could be exceeded to a distance of 361 yards (330 meters). Concentration profiles at 200 and 300 yards (183 and 275 meters) show that the ERPG-3 value is exceeded for a little over 10 minutes for a person located outdoors. At a 100-yard (92-meter) distance, the ERPG-3 value is exceeded significantly, with an exposure of about 200 parts per million lasting for about 10 minutes outdoors (see properties of chlorine gas under CHEM-02). Indoors, these values would be less, but the increment is not known due to damage to structures (with an intact single-story structure, the indoors concentration at 328 yards [100 meters] does not exceed ERPG-3, with a maximum concentration of 13.5 parts per million calculated). The circumstances of the release are such that the total release would be less than 300 pounds. The failure mode is evaluated to be shearing of the valves off the ends of the two tanks online. As discussed later under scenario CHEM-01, such a failure mode results in cooling the cylinder to a temperature less than the boiling point of chlorine, terminating the release before all the chlorine is released (actually, about half the total is released). The consequences of this would be no worse than those calculated for a single cylinder rupture, which releases 150 pounds from the building in 18.2 minutes. This results in 53 people being exposed to greater than ERPG-2 and 12 people exposed to greater than ERPG-3 concentrations under conservative daytime dispersion conditions.

- *TA-3-66, 7.6 liters of hydrogen cyanide released.* Hydrogen cyanide (HCN) would form in the basement of the Sigma Building. However, HCN is lighter than air and would be expected to evolve from solution in the basement and reach ground level, at which point it can be modeled as a ground level release. In order to place bounds on the consequences, several

scenarios were run. The most conservative release calculations assumed an instantaneous release of all 7.6 liters of HCN under adverse dispersion conditions, which is extremely conservative. The resulting maximum ERPG-2 and ERPG-3 distances were 0.60 and 0.43 miles (1 and 0.7 kilometers), respectively.

Another calculation was performed similar to those performed for EPA Risk Management Program (RMP) purposes, assuming a constant release rate with all the material released within 10 minutes under adverse dispersion conditions. The resulting maximum ERPG-2 and ERPG-3 distances were 0.45 and 0.28 miles (0.72 and 0.45 kilometers), respectively. A similar case, which assumed evaporation from a puddle under adverse dispersion conditions, produced maximum ERPG-2 and ERPG-3 distances of 0.27 and 0.17 miles (0.43 and 0.27 kilometers), respectively.

EPA RMP-type calculations under conservative daytime dispersion conditions produced maximum ERPG-2 and ERPG-3 distances of 119 yards (109 meters) and 75 yards (69 meters). Because ALOHA-calculated distances of the order of 100 yards or less are overestimates, this release scenario is of marginal consequence under conservative daytime dispersion. Even under adverse dispersion conditions, the ERPG-2 and ERPG-3 distances still did not extend to the Los Alamos townsite; any consequences would be limited to the LANL workforce population. The estimated numbers of people affected by concentrations greater than ERPG-2 and ERPG-3 are 15 and 15, respectively, for conservative daytime dispersion conditions and 44 and 29, respectively, for adverse dispersion conditions. Given collapse of the floor at Sigma, personnel in that facility would likely be severely injured or killed by the seismic event alone. Any survivors would have to rapidly evacuate the structure to avoid exposure to high concentrations of HCN.

- *TA-3-476, 150 pounds of chlorine released.* The consequences of this release are essentially identical to the consequences for accident scenario CHEM-03, as presented in Table G.5.6-1.
- *TA-9-21, 3 pounds of phosgene released.* TA-9-21 is a relatively isolated site at LANL (compared with, for example, TA-3 or TA-55) with a low workforce population in the immediate area. Nonetheless, phosgene is a very toxic gas (the ERPG-3 concentration for phosgene is 1 part per million; whereas, the ERPG-3 concentration for chlorine is 20 parts per million). Using EPA RMP-type release parameters of a constant 10-minute release under adverse dispersion conditions, the ERPG-2 and ERPG-3 distances are 0.76 and 0.032 miles (1.2 and 0.52 kilometers), respectively. Under conservative daytime dispersion conditions, the ERPG-2 and ERPG-3 distances decrease to 0.23 and 0.10 miles (0.37 and 0.16 kilometers), respectively. The estimated number of people affected by concentrations greater than ERPG-2 and ERPG-3 is 2 and 1, respectively, under either adverse or conservative daytime dispersion conditions.
- *TA-43-1, 30 liters of formaldehyde released.* This release was modeled because it is the largest inventory of easily dispersed (by air) carcinogens at LANL. The Los Alamos Medical Center is adjacent to the Health Research Laboratory, just across the bridge from LANL in the town area.

Similar to EPA RMP criteria, a 10-minute release was modeled under both adverse and conservative daytime dispersions. Under adverse dispersion, the ERPG-2 and ERPG-3 distances were calculated to be 0.68 and 0.41 miles (1.1 and 0.66 kilometers), respectively. Under conservative daytime conditions, the ERPG-2 and ERPG-3 distances were 0.17 and 0.10 miles (0.27 and 0.16 kilometers), respectively.

The number of people exposed to concentrations greater than ERPG-2 and ERPG-3 under adverse dispersion conditions are 60 and 23, respectively. Under conservative daytime dispersion, the number of people exposed to greater than ERPG-2 and ERPG-3 is 11 and 6, respectively.

The MAR (dominant contributors), earthquake frequencies, and accident conditions are the same for all four SWEIS alternatives; consequently, accident consequences across the alternatives are also projected to be comparable.

G.5.4.2 *SITE-02, Site-Wide Earthquake Causing Damage to Low- and Moderate-Capacity Structures/Internals*

As discussed in section G.5.4, the frequency of SITE-02 is 4.4×10^{-4} per year. The source term and consequences of this accident are also addressed in section G.5.4.

Consequences of SITE-02 for Facility Workers and the Public

In this earthquake scenario, the same conservative approach is used as was used in SITE-01. Facilities that sustain structural collapse would essentially consider all material in a facility as MAR. This includes stored material that could sustain damage from higher magnitude earthquakes. As with the SITE-01 scenario, for facilities that sustain internal damage only, the process material is considered to be at risk. Facilities that do not sustain damage do not contribute to MAR. Once the facility is considered to be damaged, the same conservative values (as were applied from SITE-01) for determining the source terms were used.

Moderate-capacity structures/internals subject to damage and resulting in radiological releases for a 4.4×10^{-4} annual frequency earthquake

include TA-16-205 (Weapons Engineering Tritium Facility internals damage), TA-18-32 (Kiva #2 structural failure), TA-18-116 (Kiva #3 structural failure), TA-18-168 (SHEBA structural failure), TA-50-69 (WCRRF structural failure), and TA-55-4 (Plutonium Facility internals damage). The dominant MAR and source terms for moderate-capacity structures/internals are associated with TA-50-69 and TA-55-4.

For the 4.4×10^{-4} annual frequency earthquake, the dominant source term contributors include the identified moderate-capacity structures/internals (TA-50-69 and TA-55-4) and the low-capacity structures/internals evaluated for Scenario SITE-01. The mean collective population dose is projected to total 41,340 person-rem (TEDE), resulting in approximately 24 excess LCFs. Most of the increase in exposure over the SITE-01 results comes from plutonium releases due to internal failures at the Plutonium Facility (TA-55-4); together, the TA-55-4 contribution and the contribution from the low-capacity facilities identified in SITE-01 account for 95 percent of the total integrated population dose. No acute fatalities are predicted to result from the earthquake event.

A member of the public residing at the Royal Crest Trailer Park has the potential of receiving concurrent exposures to releases from TA-3-29, TA-50-1, TA-50-69, and TA-55-4 for the postulated earthquake event. The MEI dose for this receptor location is conservatively projected to total 34.3 rem (TEDE) and primarily results from postulated releases associated with TA-55-4 (Plutonium Facility) TA-50-37 (RAMROD), and TA-3-29.

The MAR (dominant contributors), earthquake frequencies, and accident conditions are the same for all four SWEIS alternatives; consequently, accident consequences across the alternatives are also projected to be comparable.

Chemical release consequences also have been calculated. Chemical releases for SITE-02 include the same releases as for SITE-01, plus additional releases of 6,100 gallons of nitric acid and 5,200 gallons of hydrochloric acid from tanks at TA-55. These tanks are located within a few hundred feet of one another, and the consequences of the hydrochloric acid release are far greater than the nitric acid release. Accordingly, the hydrochloric acid release was modeled in detail (note that no emergency response actions are assumed, with exposure assessed as though the persons exposed are located outdoors; both assumptions are conservative). The hydrochloric acid tank is contained inside a berm; consequently, the release rate is limited by the surface area within the berm.

Consequence analyses were performed assuming a puddle of hydrochloric acid, which is the condition expected following seismic failure of the tank. The consequences of the release are provided in Table G.5.4.2-1

G.5.4.3 SITE-03, Site-Wide Earthquake Causing Damage to All Structures/Internals

As discussed in section G.5.4, the frequency of SITE-03 is 7.1×10^{-5} per year. The source term and consequences of this accident are also addressed above in section G.5.4.

Consequences of SITE-03 for Facility Workers and the Public

In this case, high-capacity facility structures are subject to damage and collapse. Once these facilities are considered to be damaged by the earthquake, conservative values are used to estimate the source terms. These values are consistent with the conservative assumptions used in SITE-01 and SITE-02, but consider the larger magnitude of this earthquakes. The increase in impacts is associated with the greater inventories that are affected by the earthquake.

High-capacity facility structures subject to damage and resulting in radiological releases for a 7.1×10^{-5} annual frequency earthquake include TA-16-205 (Weapons Engineering Tritium Facility structural failure), TA-54 Area G (TRU drums overturn), TA-55-4 (Plutonium Facility structural failure), and TA-55-185 (TRU Waste Staging Facility structural failure). The dominant MAR and source terms for this scenario are associated with TA-3-29, TA-54 Area G, and TA-55-4.

For the 7.1×10^{-5} annual frequency earthquake, source term contributions include the identified dominant high-capacity structures (TA-54 Area G and TA-55-4), the other dominant moderate-capacity (TA-50-69), and low-capacity (TA-3-29, TA-50-1, TA-50-37, TA-54-38, and TA-54 Area G) structures/internals. The mean collective population dose is projected to total 210,758 person-rem (TEDE), resulting in approximately 134 excess

TABLE G.5.4.2-1.—Consequences of a Hydrochloric Acid Release

POINT OF COMPARISON	ERPG-2	ERPG-3
Distance, Adverse Dispersion	2.0 miles	0.72 miles
Distance, Conservative Daytime Dispersion	1.0 miles	0.44 miles
Adverse Dispersion, Exposed Population	194	93
Conservative Daytime Dispersion, Exposed Population	124	36

LCFs. Projected doses and associated health effects primarily result from the postulated releases associated with TA-55-4 (accounting for almost 82 percent of the total) and TA-3-29 (accounting for an additional 14 percent of the total). No fatalities from acute radiation exposure are predicted to result from the earthquake event. The bounding dose at the MEI location in the Royal Crest Trailer Park is approximately 247 rem. The LANL seismic event exposures are almost exclusively from inhalation of plutonium, for which the exposures are more protracted and the acute effects are correspondingly reduced or absent.

The chemical release consequences for SITE-03 are the same as those for SITE-02 (section G.5.4.2).

The MAR (dominant contributors), earthquake frequencies, and accident conditions are the same for all four SWEIS alternatives; consequently, accident consequences across the alternatives are also projected to be comparable.

Recent and ongoing seismic studies have identified the potential for ground faulting at the CMR Building (TA-3-29). The assessment of ground faulting impacts on facility damage is difficult to quantify. For the CMR Building, the facility structure is assumed to collapse as part of the SITE-01 earthquake, with the CMR basement vault being intact until an earthquake magnitude comparable to a HCLPF of 0.34 g (frequency of 7.1×10^{-5} per year). The annual frequency associated with significant (greater than 50 centimeters) fault displacement is estimated to be 1 to 3×10^{-5} per year. Should fault displacement at the CMR Building occur in addition to other SITE-03 impacts, additional releases from the CMR Building could result. A conservative sensitivity assessment of this impact was completed. It should be reiterated that a detailed understanding of the additional damage and associated releases at the CMR Building has not been completed. The conservative sensitivity assessment results in an additional 133,823 person-rem collective

population dose, resulting in about 99 additional excess LCFs. The MEI doses would increase by 133.9 rem at the Los Alamos townsite and 99.3 rem at the Royal Crest Trailer Park.

G.5.4.4 *SITE-04, Site-Wide Wildfire Consuming Combustible Structures and Vegetation*

General Scenario Description

The LANL site and surrounding vicinity are generally forested areas with high fuel loading. Wildfires are frequent occurrences on nearby U.S. Forest Service land, with obvious potential for encroaching on the LANL site, as demonstrated by recent events. For this site-wide accident, it is postulated that a wildfire is initiated to the southwest of LANL near the border of the Bandelier National Monument and the Dome Wilderness Area. While there is a potential for initiation of a wildfire at many locations within and near the LANL site, this location was considered as resulting in the most widespread impact to the site and surrounding area.

The fire begins mid day in the late April through June time frame, at a time of high or extreme fire danger, and is not extinguished in the first hour. The initial location is in an area populated with heavy ponderosa pine fuels that are found between roughly 6,500 and 8,200 feet (1,980 and 2,500 meters) elevation. As the fire grows, local jurisdictions respond to the fire, but are not effective due to remoteness, travel time, lack of road access, fire behavior, etc. Resources from more distant jurisdictions are alerted, but cannot arrive in a short time because of distance, limited roads, and opposing evacuation traffic. It proves impossible to put out the fire with the available resources and existing forest access before it enters the laboratory. Unlike the Water Canyon fire (greater than 3,000 acres [1,200 hectares] in June 1954), La Mesa fire (15,270 acres [6,180 hectares] in June 1977), Dome fire (16,500 acres [6,680 hectares]

April 25 to May 5, 1996), and Oso fire (greater than 5,000 acres [2,000 hectares] in June 1998), the weather does not change in time to prevent the fire from sweeping across the western part of LANL and into the townsite.

This specific analysis assumes a common meteorological situation that favors the fire. In this scenario, the fire begins about 10:00 a.m., reaches a size of 1,000 acres (400 hectares) in 3 hours, and becomes a well developed crown fire on a broad fire front containing 6,000 acres (2,400 hectares) in the second day. Like the La Mesa fire (Foxy 1981), at times it advances at a rate of 38 chains¹ per hour (0.44 miles [0.7 kilometers]). It starts spot fires 0.5 to 1.25 miles (0.8 to 0.2 kilometers) in advance, aided by prevailing southwest winds of 20 miles per hour and low daytime humidity. It easily jumps canyons and existing fuel break lines around LANL and the townsite.

The daytime convection column reaches to 20 or 25,000 feet (6 to 7,600 meters). In the Oso fire, the fire burned as actively at night as in the day, with flame heights on the order of 100 feet (30 meters). In this scenario, in order to have a conservative (low height) plume rise, at night the temperature drops and the relative humidity increases. The nighttime plume rise is then about 2,000 feet (600 meters). The fire regains its intensity at 10:00 a.m. each day. Following fire passage, the smoldering remains of vegetation and structures emit smoke and contaminants at the surface level.

The fire reaches State Road 4 and State Road 501, the southwest edge of LANL, at noon on the second day (see Figure G.5.4.4-1). Protective actions are already underway by LANL, such as relocating some radionuclides and barricading some windows, and releasing nonessential personnel following existing emergency plans. (Note that for this analysis, credit is given only for those protective measures that can be easily undertaken, such as

ceasing operations or simple material transfers, are given credit.) The fuel break along these roads proves inadequate. At this point, the fire has progressed in areas where access is limited, hampering fire suppression activities due to concern for the safety of the firefighters. A control line is established at Pajarito Road and resources are concentrated there. Consequently, Pajarito Road is closed and not available for public evacuation. The fire burns forest to the west of and within LANL, but its eastern extent within LANL is constrained by pinyon-juniper woodlands and defined by fuel continuity and density.

From aerial photographs, it is estimated that these continuous fuel lines threaten TA-37, TA-15, TA-16, and TA-66, and those TAs to their west, as well as areas in and on the edge of the forested canyons. Following the continuous fuel lines and steered somewhat by southwesterly winds, the fire enters and crosses Pajarito Canyon and Two Mile Canyon, and by 1:00 a.m. of the third day burns up to the Pajarito Road control line just west of TA-66.

Although it would be expected that the control line will contain most fires, in this conservative accident scenario an adverse meteorological situation exists. At noon on the third day, aided by a modest daytime wind speed pickup and low relative humidity, the fire crosses the Pajarito Road control line between TA-3 and TA-55. It surrounds TA-3 and TA-48, and enters Los Alamos Canyon either directly or by spotting. The fire continues down Los Alamos Canyon on both sides of Omega Road where TA-41 and TA-2 are located. Because Omega Road continues down Los Alamos Canyon as a dirt road below the Omega site, it is unsafe for firefighters to enter Los Alamos Canyon, and the fire progresses essentially unabated.

From Los Alamos Canyon, the fire climbs onto the mesas where TA-53 and TA-21 are located. The fire also spots into Mortandad Canyon. The canyon fires are necessarily allowed to burn eastward, due to their inaccessibility, until they

¹. 80 chains = 1 mile (1.6 kilometers).

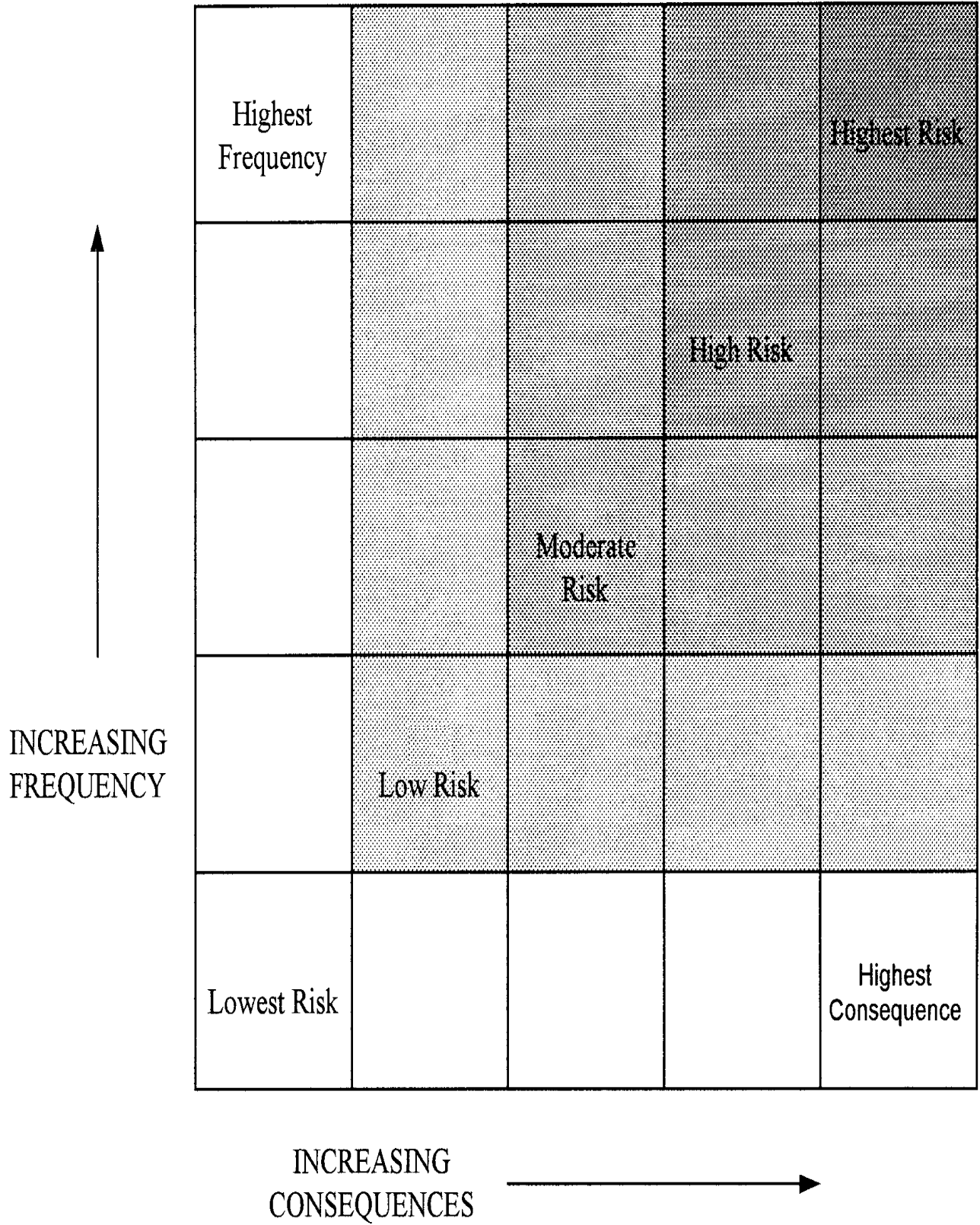

FIGURE G.5.4.4-1—Location of the Los Alamos National Laboratory.

reach the thinner stands of pinyon-juniper common to the lower parts of the canyons. There they come under control, by wind and weather changes, lack of fuel continuity, by human interference, or some combination of these. When there are sufficient trees on the canyon walls, fire climbs the walls and then ignites combustible structures and fuel at the canyon edges. It enters the townsite early on the fourth day after initiation.

An alternative fire scenario could have the fire initiate to the west of LANL and townsite in the Santa Fe National Forest of mixed conifer and ponderosa pine. This crown fire, similar to the Oso fire of 1998, travels downslope somewhat more slowly on a broad front. This fire spots only 1/4-mile or more in advance. The present, relatively narrow fuel break around the town and laboratory along State Road 501 would be overreached. This fire also would consume the ponderosa pine and combustible structures in continuous fuel areas over the same western part of LANL and townsite, and the fire would spread down the lengths of canyons until it encountered thin pinyon-juniper stands. It also could not be fought successfully because there is no access to the National Forest west and north of LANL and townsite, and because there is no north-south fuel break comparable to Pajarito Road where a control line can be established and defended. This alternative is not analyzed because the selected scenario is believed to maximize the exposure to the Los Alamos townsite from laboratory releases. The final acreage burned in both scenarios is on the order of 27,000 acres (10,900 hectares) of which about 8,000 acres (3,200 hectares) are within LANL boundaries.

On the LANL site, the fire is assumed to consume all combustible structures in its path that are evaluated as having moderate or higher risk from wildfire under the LANL Building Appraisal Program. The fire also exposes the surface of contaminated earth previously protected by vegetation in the firing sites and canyons. This text separately discusses the

exposures from fire burning the soil cover and suspending the underlying soil, and the exposures from burning structures. Exposures from canyon fires are calculated individually, thus enabling the assessment of fires of lesser extent than the site-wide fire.

This accident analysis does not consider off-site damage directly caused by the flames and smoke from LANL fires, and does not address the direct effects of the fire on the townsite. It is recognized that there is continuous fuel joining the National Forest and the residential areas, and that fires in the canyons at LANL also could propagate into the townsite.

Wildfire Frequency

Conditions that Favor Wildfire. These scenarios are quite credible, in view of the present density and structure of fuel surrounding and within LANL and townsite, as well as the occurrence of three major fires in the past 21 years. Some protection is afforded LANL by the fire scars of the previous Dome and La Mesa fires, but there is ample fuel continuity remaining to bring an off-site wildfire to the southwest and western boundary of LANL.

The probability of high to extreme fire danger is determined by the frequency of meteorological conditions of low precipitation for 2 to 3 weeks preceding; low relative humidity for 3 consecutive days; and high temperatures. When the high to extreme fire danger exists in New Mexico in May through July, there are certain to be multiple ignition sources (from lightning, carelessness, and human causes). There is a high frequency of lightning and lightning-caused fires in the Jemez Mountains (Armstrong 1998). From 1975 to 1996, there were 372 fire starts (17.7 per year) in the 40,000 acres (16,000 hectares) of Santa Fe National Forest and Bandelier National Monument adjacent to LANL. Using as input the frequency of different sized fires, the PROBACRE model yielded a 30 percent probability of exceeding

5,000 acres (2,000 hectares) in a 5 year period (Armstrong 1998). Armstrong's calculation was made prior to the 1998 Oso fire, whose inclusion would increase the probability.

The frequency of a large fire encroaching on LANL is estimated as the joint probability of ignition in the adjacent forests, high to extreme fire danger, failure to promptly extinguish the fire, and a 3-day spell of southwesterly to westerly wind over 11 miles per hour (5 meters per second), low humidity, and no precipitation.

Determining the Joint Probability of Occurrence of Weather and Fire Danger Conditions. The probability of occurrence of the weather and fire conditions needed for this scenario were determined using wind data and fire danger data for April through June of 1980 through 1998. These months were chosen on the general knowledge that fire risk and frequency is greater in those months. Note that site-wide fires also are possible, but less probable, in other months besides April through June; thus, the annual frequency of fire-favorable weather is somewhat greater than quantified for April through June.

The fire danger was determined using Energy Release Component (ERC) data obtained from Bandelier National Monument (PC 1998b). The ERC is a component of the National Fire Danger Rating System, and the adjective ratings, such as "moderate" or "extreme," are determined from categories of the ERC, with higher values of the ERC representing conditions of higher fire danger. Above a threshold value of the ERC, the fire danger is "very high" and "extreme," and this threshold value was used to determine days of very high and extreme fire danger. Interpolation was performed to estimate for days when ERC data was missing.

In general, wind direction at any location varies and does not persist in a single direction for a few days. LANL is no exception. At LANL, persistent daytime winds are interrupted for a few hours when nighttime drainage winds

occur. However, granting short interludes of drainage flow, there are many instances in which a dominant direction, such as southwesterly, westerly, northerly, etc., can exist for 3 days without precipitation.

For determining fire-favorable weather frequency, 15-minute average wind data from the 11.5-meter level of the TA-59 and TA-6 meteorological towers were used. For each day in April through June of 1980 through 1998, an average afternoon wind was calculated from the 15-minute data in order to eliminate local diurnal changes in wind speed and direction that are common to the area. Average afternoon wind speeds of greater than 10 miles (16 kilometers) per hour were chosen to represent strong winds. While this threshold may seem low for a strong wind, wind gusts of over 30 miles (48 kilometers) per hour and sometimes over 40 miles (64 kilometers) per hour were seen on most days when the afternoon average wind was above 10 miles (16 kilometers) per hour. The wind direction thresholds were set at 180° (southerly, meaning from the south) through 292.5° (west-northwesterly). Three-day periods from the same data set were then examined to determine if the ERC, wind speed, and wind direction fell above (or within) set thresholds. All 3-day periods falling within the set limits were then extracted.

The results show that it is not uncommon to see a 3-day period exhibiting the selected characteristics in a given year, and that when such a 3-day period appears, it is likely that more than one such period will occur within that year. Specifically, the resulting statistics show that of the 19 years examined, 5 of them displayed at least one 3-day period within the limits, or 1 every 4 years. Of these 5 years, 4 of them had an average of 3.6, 3-day periods. (An instance of 5 days in a row is counted as 3, 3-day periods.) This comes to 15.4 instances in 19 springs.

In summary, fire-favorable weather conditions occur on the order of once per year; the ignition sources are prevalent; and fire fighting is hampered by limited accessibility. Therefore, this analysis concludes that a major fire moving up to the edge of LANL is not only credible but likely, probably on the order of 0.1 per year. This frequency is the same for all alternatives.

Dispersion Meteorology

As noted, only certain meteorological conditions are compatible with such a fire. The meteorology of June 7 to 10, 1998, was selected for modeling the accident sequence because these dates were recognized as a recent time of serious fire danger to LANL. These conditions are regarded as conservative, in that in this period the wind is generally from LANL toward the nearby Los Alamos townsite and would result in higher total population doses. Santa Fe is much more distant, and concentrations would therefore be lower. Under northwesterly winds, exposures in Santa Fe (had the alternate scenario been used) would surely be less than exposures to the Los Alamos townsite from the southwesterly winds in this scenario.

Exposures at 100 meters distance from burning exposed soils are calculated using C stability and 6.6 feet (2 meters) per second wind speed. These exposures can be regarded as MEI exposures, although it is unlikely that anyone other than firefighters will be present at that distance. Exposures at 3,300 feet (1,000 meters) are also reported. In canyons, where elongated area sources exist, the calculation provides integrated exposure at 330 and 3,300 feet (100 and 1,000 meters) downwind of the long axis of the area, thus maximizing the exposure. This situation could occur with winds turning to follow the canyon profile, such as under drainage wind conditions. Thus, the calculation applies to plumes that are destined for any receptor within and beyond the contaminated sections of the canyons.

Soil Resuspension Following the Fire

Suspension by the wind of a fraction of the surface soil can occur following denuding of the vegetation. This has the potential of exposing workers returning to the area, as well as the transient public, until the situation has stabilized and vegetation has begun to recover. As proven by the continuing existence of soil and ash following a fire, the suspension of fire residue and of burned soil is very small compared to the bulk quantity that continues to remain. Only the loose material would be suspended, and, if the material is not mechanically disturbed, the rate of suspension would taper off. Even if precipitation halting the suspension did not occur, the wind direction would change many times so that the resuspended material would not be transported as effectively as that from the shorter term, initial release. Consequently, resuspension doses are only calculated for an individual standing directly on the contaminated area.

Large, brief suspensions for unweathered materials occur under mechanical disturbance, such as the passage of vehicles. This is highly dependent upon vehicle speed and wind speed (Figure 4-23, DOE 1994d). The highest, bounding resuspension rate is 1×10^{-2} per passage for a car driven directly through powder tracer material on an asphalt road (DOE 1994d). However, there are no asphalt roads and no fast vehicle traffic on the firing ranges, and most of the contamination is not near roads. Hence, suspension by vehicles will not be of this magnitude and is not included in this analysis. Rather, the direct suspension by the wind is analyzed.

A rate of resuspension is often expressed as the ratio of the airborne concentration and the areal surface contamination, usually with the units of meters⁻¹. This ratio is called the resuspension factor. Its magnitude depends upon the wind speed, particle size, and nature of the cover. The

resuspension factor decreases with time due to weathering and downward migration of a portion of the contamination. Although most material remains in the surface soil, it becomes unavailable to the wind. Sehmel (1984) provides a substantive discussion of resuspension factors, their use, and limitations. Note, this concept strictly applies to the resuspension of material deposited from the atmosphere and applied to the soil as tracers in experiments and may not apply to material otherwise incorporated in the soil matrix. Most resuspension factors range from 10^{-5} to 10^{-11} per meter.

Note that the resuspension factor is not the fraction of the material that becomes airborne, and therefore cannot be treated as an airborne release fraction (ARF) or source term for dispersion models. Because of the way the resuspension factor is defined and measured, the concentrations apply only in the immediate vicinity (i.e., above) the contaminated soil. Concentrations beyond the area will be much lower, due to variations in the wind direction and atmospheric diffusion.

Although resuspension factors are highly irregular and poorly defined (Sehmel 1984), they were applied to evaluate residual concerns with reoccupying burned out contamination areas. A conservative resuspension factor of 1×10^{-5} meters⁻¹ (sandy soil with charred debris) is selected for use in this analysis (from Section 4.4, Table 4-16, page 4-91, DOE 1994d). The fraction of the suspended contaminant that is respirable (less than 10 micrometers equivalent aerodynamic diameter) at the soil surface following the fire passage, is unknown. The particle size is likely to be large, as the contaminants will be attached to soil particles; but, because it is unknown, an RF of 1.0 is assumed. The appropriate time period for application of this conservative value is probably only a few days long, depending upon precipitation, because resuspension factors decrease by several orders of magnitude with time.

The resuspension factor of 1×10^{-5} meters⁻¹ was applied to the mean areal soil concentration in the top layer of the contaminated sites, with the resultant radiological exposures shown in Table G.5.4.4.-1. These are the estimated exposures that could occur if all the contamination in the top soil layer were right at the surface, if there were no precipitation or soil cover, if there were wind, and if the receptor were standing above a spot that represented the average soil contamination for the contaminated portion of the site or canyon. These estimates are limited by the theoretical and experimental problems with resuspension factors.

In practice, before these known contamination areas would be reoccupied following a fire, the potential for exposure would be assessed and protective actions taken as appropriate to minimize exposure to the personnel.

Exposures from Burning Vegetation and Suspended Soil

Open Burn/Open Detonation Dispersion Model. During the burning of a vegetative cover, some fraction of the soil is entrained into the fire and transported and dispersed downwind. Such downwind concentrations of soil contaminants suspended by fire were calculated using the Open Burn/Open Detonation Dispersion (OBODM) model. The Open Burn/Open Detonation Dispersion Model (OBODM) is intended for use in evaluating the potential air quality impacts of the open-air burning and detonation of obsolete munitions and solid propellants at U.S. Department of Defense and DOE installations (DPG 1997). It can be used to calculate peak concentration, time-mean concentration, time-integrated concentration, and particulate deposition from multiple sources. It can consider instantaneous or quasi-continuous releases from point, volume, and/or line sources.

The model predicts buoyant rise of the plume from the burn and uses default mixing depths generally representative of noncoastal regions

TABLE G.5.4.4-1.—Estimated Inhalation Doses from Resuspension Following Wildfire

SITE	AREA (m ²)	TOTAL SOIL CONTAMINATION	MEAN SOIL SURFACE CONCENTRATION	AIR CONCENTRATION	INTAKE PER DAY ^a	EFFECTIVE DCF ^b (mrem/ μ Ci)	RECEPTOR DOSE (mrem/day)
EF Site	11,690	675 kg DU	0.058 kg/m ²	5.8 x 10 ⁻⁷ kg/m ³	17.5 mg ^c 5.8 x 10 ⁻³ μ Ci	1.18 x 10 ⁵	690
Phermex Site	11,690	568 kg DU	0.049 kg/m ²	4.9 x 10 ⁻⁷ kg/m ³	14.7 mg ^c 4.9 x 10 ⁻³ μ Ci	1.18 x 10 ⁵	579
Potrillo Canyon	1,200	58 kg DU	0.048 kg/m ²	4.8 x 10 ⁻⁷ kg/m ³	14.6 mg ^c 4.9 x 10 ⁻³ μ Ci	1.18 x 10 ⁵	575
Mortandad Canyon	13,600	4.7 x 10 ⁹ pCi mixed	3.4 x 10 ⁵ pCi/m ²	3.44 pCi/m ³	1.0 x 10 ⁻⁴ μ Ci	1.58 x 10 ⁵	16.4
DP Canyon	3,600	1.6 x 10 ⁷ pCi TRU	4,480 pCi/m ²	0.044 pCi/m ³	1.4 x 10 ⁻⁶ μ Ci	4.34 x 10 ⁵	0.58
Los Alamos Canyon	18,900	1.2 x 10 ⁸ pCi TRU	6,560 pCi/m ²	0.066 pCi/m ³	2.0 x 10 ⁻⁶ μ Ci	4.33 x 10 ⁵	0.86
Acid Canyon	100	1.6 x 10 ⁷ pCi TRU	1.6 x 10 ⁵ pCi/m ²	1.64 pCi/m ³	5.0 x 10 ⁻⁵ μ Ci	4.35 x 10 ⁵	21.6
Pueblo Canyon	28,500	2.5 x 10 ⁸ pCi TRU	8,912 pCi/m ²	0.089 pCi/m ³	2.7 x 10 ⁻⁶ μ Ci	4.3 x 10 ⁵	1.2

Notes:

^a The breathing rate used is 30.24 m³/day.^b The effective dose conversion factors are for the mixture of nuclides at each firing site and canyon.^c These intakes of uranium would exceed the OSHA PEL of 0.25 mg per 8 hours.

in the western United States. The minimum meteorological input consists of wind speed and direction at 10 miles elevation, air temperature, and the Pasquill stability category or the Net Radiation Index. For OBODM wildfire calculations, a conservative stability and wind speed (category C and 2 meters per second at 10 miles height) were selected to maximize the downwind exposures. A stable atmosphere would not represent the mixing conditions in the daytime meteorological situations favorable to a wildfire, and could not exist in the presence of the wildfire.

Vegetation Fire Plume Rise. The OBODM model calculates the plume rise given a fuel loading, rate of burn, and heat content of the fuel. It calculates the resulting concentration distribution at specified receptor points. The fuel model classes and associated rates of burn (defined pursuant to Anderson 1982) were determined by field survey (PC 1998c) and are given in Table G.5.4.4-2.

Caloric values of various terrestrial food plants and seeds are 4.5 to 5.2 cal/gm (Odum 1971). The heat content of dead cellulosic materials does not vary greatly (Simard et al. 1989). For this analysis, the heat content of both grass and of wood were assumed to be 4.95 cal/gm (20.7 J/gm) (Wilgen et al. 1990). The fuel models contain the sum the dead and live vegetation in various conditions of dryness and have an associated rate of fire spread. The range of uncertainty in the fuel load is large enough that the uncertainty in the moisture content, heat content, and rate of burn is not material. The total heat produced is used only to calculate the plume rise, which has only a modest effect on concentrations at moderate to large distances from the source.

Areas of Contaminated Soil Analyzed. The areas of contaminated soil were identified as PHERMEX Firing Site and EF Firing Site in TA-15, Potrillo Canyon (from runoff at the EF Firing Site), DP Canyon and Los Alamos Canyon below TA-21, and Mortandad Canyon

below and east of TA-35. The radioactive waste lagoon at the end of TA-35 has cattails in it, but contains water. Acid Canyon received untreated waste water until 1953, then treated waste water until 1963. It has been cleaned up, but residual contamination still shows up in the Acid Weir sediment trap. The area of contamination in Acid Canyon is estimated as 3.3 feet wide by 330 feet long (1 meter wide by 100 meters long) (PC 1998d). Acid Canyon empties into Pueblo Canyon, which also is of low concentrations. Other, numerous contaminated areas that have been covered with clean soil are not at risk of suspension during and following wildfire and therefore were not evaluated. Ten Site Canyon below the Radioactive Liquid Waste Treatment Facility in TA-50 was not evaluated, as its contamination is primarily strontium-90, which has a lower dose conversion factor than plutonium and because it has such low concentrations that it is no longer sampled (PC 1998e).

The contamination levels were obtained from several publications, as identified at various places in this text and in the summary Table G.5.4.4-2. To be conservative, the total amount in the upper tier of sampled soil, usually 0 to 1 or 0 to 3 inches (2.5 or 7.6 centimeters) depth, were assumed to be entirely on the surface and exposed to the fire.

Airborne Release Fractions During Vegetation Fires. The model OBODM requires as input the fraction of contamination present in the fuels being burned. For these calculations, the ratio of this suspended contamination to the mass of fuel burned over the same area was presented to the model. To get this ratio, the mass of contamination suspended during the fire passage is the product of the contamination in the top layer of surface soil and the release fraction. For this assessment, all the contamination in the top layer of soil is assumed to be released with the release and respirable fraction (ARF x RF) appropriate to uranium metal under thermal stress.

For contamination in the soil, duff and litter, the burning temperature is going to be low and the burning time short, with the fire front progressing at 0.2 to 0.44 meter per second in timber and grass, respectively. The possibility of shrapnel in trees is recognized. However, there are few trees around the firing sites, and the release fraction from burning DU is small. Uranium is not capable of continued burning after the fire has departed, and so the burning release time would be short. The ARF x RF for uranium metal under thermal stress is taken from DOE 1994d, Section 4.2.1.2.1, page 4-42. The observed geometric mean ARF x RF is 1×10^{-4} , with a 95 percent confidence level ARF x RF of 4×10^{-4} . In this analysis, the value 4×10^{-4} also is used for beryllium and its compounds in the absence of experimental data dealing directly with beryllium. There are no release fractions available for radionuclides other than plutonium and uranium in the DOE-HDBK-3010-94 (DOE 1994d) or in the Nuclear Fuel Cycle Facility Accident Analysis Handbook NUREG/CR-6410 (NRC 1998). The bounding ARF x RF for powders subjected to thermal stress are 6×10^{-5} for nonreactive compounds and 1×10^{-5} for reactive compounds (DOE 1994d, Section 4.4.1, page 4-61). For consistency, the conservative ARF x RF of 4×10^{-4} also was used for other nuclides in contaminated soils.

Contamination in Plants and Animals. Small mammals have tissue/soil uranium ratios of 10^{-3} and 10^{-4} (Miera et al. 1980), and tissue/soil cesium and strontium ratios on the order of 1.0 (Whicker and Schultz 1982, Table 17). (It is unclear whether these ratios are wet or dry weights in the animals, plants, and soils.) For the reasons of their low concentration ratios, their escape ability, and their very small total mass compared to that of the vegetation, animals are ignored as a source of airborne nuclides in this analysis.

The NRC has published a list of plant/soil concentration ratios (NRC 1977). The ratios for stable strontium and cesium are 0.017 and 0.01,

respectively, although there will be cases where observed values differ substantially (Whicker and Schultz 1982). Whicker and Schultz stated that the ratios for uranium range from 10^{-4} to over 10^{-1} , that ratios for plutonium are particularly dependent on chemical form, and that ratios for americium are perhaps 100-fold higher than plutonium. Plants growing where uranium concentrations in surface soils were 20 times to 3,500 times background, have exhibited uranium concentration factors of 0.05 (spring) to 0.08 (fall). Late fall standing dead vegetation at the EF site averaged 320 micrograms uranium per gram of dry vegetation (Miera et al. 1980). Applying this observation, the 1,987 kilograms of vegetation at the EF site would contain 0.64 kilogram of depleted uranium, all of which would presumably become airborne in the fire. Application of the ARF of 4×10^{-4} to the EF site soil would produce 0.27 kilogram of airborne depleted uranium. Thus, the dose from burning vegetation could contribute 2.37 times the dose from the suspended soil, and the doses could be 3.37 times the value given for soil alone in the final column of Table G.5.4.4-2.

Wenzel et al. (1987) studied radionuclide concentrations in soil, litter, and vegetation growing in a TRU waste area, and concluded that a higher resolution sampling is needed for cesium-137 and plutonium-239/plutonium-240 to interpret surveillance results and produce reliable risk assessments. Their observations, suggest that the concentrations of these nuclides, and of depleted uranium, in vegetation is always less than the concentrations in the top 0.8 inch (2 centimeters) of soil, and generally an order of magnitude less.

Thus, it is concluded that the doses in the final column of Table G.5.4.4-2 could be increased by a factor of three or four to account for the contamination in the vegetation above ground that becomes airborne.

Beryllium Exposures. The 8-hour time weighted average for worker exposure to

TABLE G.5.4.4-2.—Summary Table for Contaminated Soil Areas

SITE	PHYSICAL DIMENSIONS	MEAN SOIL CONTAMINATION	FUEL TYPE FUEL MODEL	BURN RATE	FUEL LOADING	RECEPTOR DOSE AT 100 m AND 1,000 m
EF Site ^a	200 ft/61 m radius 11,690 m ²	542 ppm area-weighted uranium ^b ; 675 kg total	Grass Fuel Model 1	78 chain/hr (0.44 m/s)	1,987 kg; 0.74 ton/ acre (0.17 kg/m ²)	0.21 mrem (0.01 mrem)
PHERMEX Site ^a	200 ft/61 m radius 11,690 m ²	456 ppm area-weighted ^b ; 568 kg total	Grass Fuel Model 1	78 chain/hr (0.44 m/s)	1,987 kg; 0.74 ton/ acre (0.17 kg/m ²)	0.18 mrem (0.008 mrem)
PHERMEX Site ^c	200 ft/61 m radius 11,690 m ²	Simple average 31.7 ppm Beryllium in 0 to 3 inch soil depth ^d	Grass Fuel Model 1	78 chain/hr (0.44 m/s)	1,987 kg; 0.74 ton/ acre (0.17 kg/m ²)	0.8 µg/m ³ (0.0005 µg/m ³) ⁱ
Potrillo Canyon ^e	4 m x 300 m 1200 m ²	58 kg uranium 0 to 15 cm depth	PIPO-Canyon Fuel Model 2	35 chain/hr (0.20 m/s)	566 kg; 2.1 ton/ acre (0.47 kg/m ²)	0.0016 mrem (3.5 x 10 ⁻⁴ mrem)
Mortandad Canyon ^g	4 m x 3,400 m 13,600 m ²	Surface inventory of 4.7 x 10 ⁹ pCi of mixed nuclides	PIPO-Canyon Fuel Model 2	35 chain/hr (0.20 m/s)	6,415 kg; 2.1 ton/ acre 0.47 kg/m ²	4.7 x 10 ⁻⁴ mrem (3.6 x 10 ⁻⁵ mrem)
DP Canyon ^{f,g}	3 m x 1,200 m 3,600 m ²	1.6 x 10 ⁷ pCi TRU surface inventory	PIPO-Canyon Fuel Model 2	35 chain/hr (0.20 m/s)	1,700 kg; 2.1 ton/ acre (0.47 kg/m ²)	2.8 x 10 ⁻⁴ mrem (1.6 x 10 ⁻⁴ mrem)
Los Alamos Canyon ^g	3 m x 6.3 km 18,900 m ²	1.2 x 10 ⁷ pCi of TRU surface inventory	PIPO-Canyon Fuel Model 2	35 chain/hr (0.20 m/s)	8,920 kg; 2.1 ton/ acre (0.47 kg/m ²)	1.5 x 10 ⁻⁷ mrem (1.4 x 10 ⁻⁷ mrem)
Acid Canyon ^{g,h}	1 m x 100 m 100 m ²	16.4 x 10 ⁶ pCi of TRU surface inventory	PIPO-Canyon Fuel Model 2	35 chain/hr (0.20 m/s)	47.2 kg; 2.1 ton/ acre (0.47 kg/m ²)	4.1 x 10 ⁻⁵ mrem (3.0 x 10 ⁻⁶ mrem)
Pueblo Canyon ^g	3 m x 9.5 km 28,500 m ²	2.5 x 10 ⁸ pCi of TRU surface inventory	PIPO-Canyon Fuel Model 2	35 chain/hr (0.20 m/s)	13,450 kg; 2.1 ton/ acre (0.47 kg/m ²)	2.2 x 10 ⁻⁸ mrem (2.0 x 10 ⁻⁸ mrem)

^a Data from DOE 1995a, Appendix D.

^b 456 ppm and 542 ppm area-weighted average depleted uranium in 0 to 3 inch depth of surface soil of density 1.4 g/cm³ yield 568 kg and 675 kg depleted uranium.

^c Data from Fresquez 1994, results of the soil sampling survey conducted over active RCRA firing site TA-15-184 (PHERMEX).

^d Simple average concentration in surface soil of density 1.4 g/cm³.

^e Data from Miera et al. 1980.

^f Width and length from PC 1998f.

^g Data from Environmental Surveillance Reports (ESR) for 1992 (LANL 1994e), 1995 (LANL 1996r), and 1996 (LANL 1997c).

^h Data from Acid Weir site, Table 5-14 of ESR 1996.

ⁱ For beryllium, rather than the TEDE or integrated concentration, the peak concentration is provided for comparison to standards. The acceptable maximum peak for a maximum of 30 minutes is 25 µg/m³ (NIOSH 1997).

^j Due to the very long line source oriented down the canyon and the wind blowing down the canyon, dose does not change much with distance down the canyon. In fact, at 10,000 m in Los Alamos Canyon, the dose is effectively the same as at 1,000 m.

beryllium and its compounds is 0.002 milligram per cubic meter. The acceptable maximum peak for a maximum duration of 30 minutes is 0.025 milligram per cubic meter (NIOSH 1997). These are not thresholds that will protect all people but are useful for comparison to the concentrations from burning over the PHERMEX site. The beryllium concentrations calculated by OBODM (Table G.5.4.4-2) were 0.0008 milligram per cubic meter, much less than these thresholds.

Conclusions as to Doses Downwind from Firing Sites and Canyon Fires. The doses at 330 feet and 3,300 feet (100 meters and 1,000 meters) downwind from fires over individual firing sites and canyons are provided in Table G.5.4.4-2. The doses assume that the receptor remains at those locations for the full time of the plume passage. This can be a long time, as the fire front advances at about 0.7 foot per second (0.2 meter per second) in the canyon timber. At this speed, the fire takes 13.5 hours to burn the contaminated area of Pueblo Canyon, 8.9 hours for Los Alamos Canyon, 4.8 hours for Mortandad Canyon, and 1.7 hours for DP Canyon, but only 0.42 hours for Potrillo Canyon and 20 minutes for the EF site.

The largest doses from the vegetation fires are at 330 feet (100 meters) downwind of the firing sites, EF (0.21 millirem), and PHERMEX (0.18 millirem). The 5×10^{-7} LCF per millirem risk factor can be applied to the doses in Table G.5.4.4-2, to receive assurance that there are no effects expected from the radiological exposures from burning vegetation and ground cover over soils. If the total area of contamination is small, such as for the firing sites and Acid Canyon, then the same values would apply for any wind direction. For the other canyons, however, the exposure is integrated for the entire length of the canyon fire, and so the exposure to the side of the canyon would be less than given in Table G.5.4.4-2.

Because the canyons are parallel, a receptor cannot be directly downwind from more than one canyon, and hence, the exposures from multiple canyons should not be added to obtain a new MEI dose. In order for a receptor to receive exposure from multiple canyons, the wind would have to be transverse to them, as it would be in this site-wide fire with the southwesterly winds. However, if the wind were transverse to multiple canyon fires, the orientation of the canyons would assure that the dose from each would be much less than those shown at 100 meters distance in Table G.5.4.4-2. One must conclude that, no matter the orientation of the wind, sources, and receptors, the MEI dose from site-wide vegetation fires must be less than 1 millirem.

Delayed Emissions Following Building Fire

The smoke or emissions from building remains following the fire passage were not modeled. The entrainment of surrounding air by strong fires will capture much of the delayed emissions that occur soon after passage of the fire front, converting them into an elevated release as part of the main fire. However, in the LANL landscape there may not be an intense, continuous fire front; hence, some of the contaminants in the surface emissions may travel and disperse at low elevations. The relative amount of the contaminant that is and is not entrained into the main fire plume cannot be evaluated.

Evaluation of Building Fires

This section analyzes potential individual and population radiological and chemical exposures from buildings burning as a result of wildfire initiation. Each building was first screened for its vulnerability to wildfire. Those that were evaluated as vulnerable were then screened for chemical and radiological inventories. For those with significant inventories, the doses from the fires were then obtained from previous fire analyses (such as in SARs or this SWEIS) or newly calculated using the MACCS code.

Criteria and Process for Determining Building Vulnerability to Wildfire. The evaluation of vulnerability to wildfire is on the basis of building construction, materials and exposure, slope, and the quantity and structure of external fuel as described below. The total wildland fire vulnerability was calculated for this SWEIS by the LANL Fire Protection Group. The vulnerability is the product of the structure hazard times the sum of the fuel hazard and slope hazard, as defined below.

The Structure Hazard Rating considers the combustibility of the exterior structure:

- Underground—0
- Noncombustible exterior (windowless)—1
- Noncombustible (window exposures)—2
- Combustible exterior—3

Fuel Hazard. This is the product of two components, fuel loading and distance factor. The fuel loading is taken as zero for short grass and asphalt, and for other conditions is determined by the fuel model type, as described in *Aids to Determining Fuel Models For Estimating Fire Behavior* (NWCGP 1982).

The distance factor, DF, expresses the distance of the fuel from the structure.

- DF—0, distance is greater than 4 times the height of the fuel.
- DF—1, distance is greater than 2 times the height of the fuel.
- DF—2, distance is the height of the fuel.
- DF—3, distance is less than 1/2 the height of the fuel.

Slope Hazard. Exposing slopes are rated as follows:

<u>Slope Hazard</u>	<u>Slope</u>
5	Mild (0 to 5%)
10	Moderate (6 to 20%)

15	Steep (21 to 40%)
20	Extreme (41% and greater)

The total vulnerability is then calculated as the product of the structure hazard times the sum of the fuel hazard and slope hazard. This number is converted to a word description as follows:

<u>Numerical rating</u>	<u>Vulnerability</u>
0 to 5	None
6 to 49	Very Low
50 to 79	Low
80 to 149	Moderate
150 to 259	High
260 and above	Extreme

Note that this LANL system does not provide a probability that a wildfire will approach the building, or that any particular building **will** burn in a fire. Rather, it sorts which buildings are more likely to be damaged or destroyed should a wildfire approach. Table G.5.4.4-3 lists the buildings that have a moderate or higher risk, have also been assigned a hazard category in the publication LANL 1998a, and were subsequently evaluated for public exposure from wildfire. Other buildings have no significant amounts of MAR and were not evaluated for this accident analysis.

For each building that has a moderate or higher vulnerability and appears in LANL 1998a, a determination was next made as to whether further analysis of public exposure was needed. Table G.5.4.4-4 provides the results. Some buildings were eliminated based on updated inventories, as having no significant inventories, or an inventory that was present only for brief periods. These determinations appear in the columns headed "Comments and EIS Assessment." The comments column

TABLE G.5.4.4-3—Evaluation of Vulnerability of LANL Buildings to Wildfire

TECHNICAL AREA	BUILDING	WILDLAND RISK	NUCLEAR FACILITY	HAZARDS	CONST. TYPE	COMMENTS, AND TENTATIVE INVENTORY PENDING VERIFICATION
TA-02	44	Moderate	No	Rad	1	
TA-02	49	Extreme	No	Rad	3	Cooling Tower
TA-03	130	Moderate	Yes	Rad	2	
TA-03	16/208	High	No	Rad	2	
TA-03	494	Moderate	No	Rad	2	
TA-03	66/451	High	Yes	Rad, Chem	2	Nitric acid, fuming (6,484 lbs.), hydrochloric acid (3,130 lbs.), hydrofluoric acid 48 to 51% (490 lbs.)
TA-08	65	Moderate	No	Rad	1	
TA-08	70	Moderate	Yes		2	
TA-15	183	Moderate	No	Rad	2	
TA-16	205	Moderate	Yes	Rad	2	
TA-16	248	Moderate	No		2	
TA-16	255	High	No		3	Exposes 16 to 205
TA-16	414	Moderate	No	Rad	2	
TA-16	459	High	No		3	Exposes 16 to 205
TA-18	32	Moderate	Yes	Rad	2	
TA-21	155	Moderate	Yes	Rad	2	
TA-21	209	Extreme	Yes	Rad, Chem	2	
TA-21	61	Moderate	No		2	
TA-35	110	High	No	Rad	3	
TA-35	213	High	No	Rad, Chem	2	Nitric acid (406 lbs.)
TA-41	2	Moderate	No		2	
TA-41	30	Moderate	No		2	Outside rad storage
TA-41	4	Moderate	No		2	
TA-43	1	Extreme	No	Rad, Chem	2	Hydrochloric acid (483 lbs.)
TA-46	208	Moderate	No	Rad	3	
TA-46	217/218	Moderate	No		3	Exposes 46 to 75
TA-48	1	Moderate	No	Rad, Chem	2	Sulfuric acid 14% (2,400 lbs.), hydrogen fluoride solution (663 lbs.), chlorine (223 lbs.)

TABLE G.5.4.4-3—Evaluation of Vulnerability of LANL Buildings to Wildfire-Continued

TECHNICAL AREA	BUILDING	WILDLAND RISK	NUCLEAR FACILITY	HAZARDS	CONST. TYPE	COMMENTS, AND TENTATIVE INVENTORY PENDING VERIFICATION
TA-48	45	Moderate	No	Rad, Chem	2	Nitric acid (1,812 lbs.), hydrochloric acid (545 lbs.), hydrofluoric acid (23 lbs.). Bldg. not in LANL 1998a
TA-51	11	Moderate	No	Rad	2	
TA-51	12	Moderate	No	Rad	2	
TA-53	1	Moderate	No	Rad	2	
TA-53	3	Moderate	No	Rad, Chem	2	
TA-53	Rad Waste Lagoon	Moderate	No	Rad	2	
TA-54	153	Moderate	No	Rad	3	
TA-54	215	Moderate	No	Rad	3	
TA-54	224	Moderate	No	Rad	3	
TA-54	226	Moderate	No	Rad	3	
TA-54	229	High	No	Rad	3	
TA-54	230	High	No	Rad	3	
TA-54	231	Moderate	No	Rad	3	
TA-54	232	Moderate	No	Rad	3	
TA-54	283	Moderate	No	Rad	3	
TA-54	33	High	No	Rad	3	
TA-54	48	Moderate	No	Rad	3	
TA-54	49	Moderate	No	Rad	3	
TA-54	Area G, Pad 2	Moderate	No	Rad	3	
TA-55	107	Moderate	No		3	
TA-59	118	High	No		3	
TA-59	119	High	No		3	
TA-59	32/33/34	Moderate	No		3	
TA-59	35/36/37	Moderate	No		3	

Notes: For construction type, 0 = Underground, 1 = Noncombustible/Windowless, 2 = Noncombustible, 3 = Combustible.

TABLE G.5.4.4-4—Final Vulnerability and Consequence Assessment of Building Wildfires

TECHNICAL AREA	BLDG. NO.	FACILITY NAME	COMMENTS	SWEIS ASSESSMENT
TA-02	4	Laboratory Storage Building, OWR	Former Facility Manager stated that no residual contamination exists in this building, and it would not add contaminants to the plume during a wildfire.	Eliminated based on no residual contamination or inventories.
TA-02	44	Laboratory Storage Building OWR	Former Facility Manager stated that two resin exchange columns exist in this building, and samples could be collected and analyzed to determine the amount of contamination that currently remains in the ion exchange columns. He indicated that the remaining contamination would be very small and may contain cobalt-60.	No data available and therefore could not be analyzed. Public exposures from the small inventory would be bounded by other building fires. Facility is scheduled for disposal.
TA-02	1	Omega West Reactor (OWR)	Former Facility Manager stated that reactor systems were flushed and analyzed as part of the decontamination and decommissioning process, the cooling systems are dry, the reactor vessel or housing is still radioactive, but is encased in a stainless steel vessel that should not burn.	Fuel has been removed; Reactor is in the process of completing any decontamination and decommissioning activities; eliminated based on no wildfire risk to inventory
TA-03	66/451	Sigma Building	130 kg of fines in oil, plus 100 electrodes each 1/4 inch thick by 8 inch by 4 ft. long. Remainder of 65,000 kg of DU is in fixed storage cabinets of 1/2 hour fire resistance. All material is in the basement. Information from facility walkdown conducted by GRAM, Inc. (Garvey 1998) nitric acid, fuming (6,484 lbs.), hydrochloric acid (3,130 lbs.), hydrofluoric acid 48 to 51% (490 lbs.).	The maximum dose from the inventory of 65,000 kg calculated for this scenario was 3.0×10^{-5} rem 50 yr. committed effective dose equivalent (EDE) at approximately 10 km from the release point (Young 1998). Chemicals below grade level and not likely to be affected by fire.
TA-08	24	Isotope Building	The facility is used only intermittently for storage of radioactive material; operations, in the event of a wildfire, would not be conducted or would be terminated and material would not be stored in this facility.	Eliminated based on the intermittent use of the facilities
TA-08	70	Nondestructive Test		Eliminated based on the intermittent use of the facilities

TABLE G.5.4.4-4—Final Vulnerability and Consequence Assessment of Building Wildfires-Continued

TECHNICAL AREA	BLDG. NO.	FACILITY NAME	COMMENTS	SWEIS ASSESSMENT
TA-15	203/213	PHERMEX Cavity Shelter	There is no known residual contamination or inventory of radioactive material in this building.	Eliminated based on no residual contamination or inventories
TA-15	313	Radiographic Support	Radiation is only present when machine is operating. Concrete blocks surround equipment; therefore, the equipment would not be at risk in a wildfire.	Eliminated based on no residual contamination or inventories of radioactive material
TA-16	205	Weapons Engineering Tritium Facility (WETF)	100 g, tritium in process; vault storage: 60 g in tubs, 1,200 g in Lp-50 Containers. Information from facility walkdown conducted by GRAM Inc. (Garvey 1998) March 2, 1998 FSAR available, No SER.	The maximum dose (MEI) was calculated as 0.25 rem at 4.85-km distance. Doses are less at shorter distances due to the plume rise. The population dose is 189 person-rem within the 80.5-kilometer (50-mile) radius. (Young 1998)
TA-18	32	Critical Assembly Building	All three kivas are concrete construction, and materials are contained in a concrete vault within the kivas.	Eliminated based on no wildfire risk to the inventories
TA-21	155	Tritium Science Test Assembly (TSTA)	200 g tritium. Information from facility walkdown conducted by GRAM Inc. (Garvey 1998).	The RAD-05 aircraft crash and fire accident consequences from a 200 g release of tritium oxide were 24 person-rem population exposure and mean MEI dose of 0.012 rem at State Road 5 (360 m). These consequences are 25% less under the Reduced Operations Alternative.
TA-21	209	Tritium Science and Fabrication Facility	100 g tritium Information from facility walkdown conducted by GRAM Inc. (Garvey 1998).	Scaling of the RAD-05 aircraft crash and fire accident consequences to a 100 g release of tritium in oxide form results in 12 person-rem population exposure and mean MEI dose of 0.006 rem at Route 502 (360 m).
TA-35	213	Target Fabrication	1 kg beryllium; 10 lbs. boron trichloride; 5 lbs. (solid), 8 kg (solutions) cyanide; 3 lbs. diborane, 3 l. formaldehyde, 4 lbs. metal carbonyls, 171 l nitric acid, 1 lb. phosphene, 20 Ci tritium, 10 kg U-235 Information from facility walkdown conducted by GRAM Inc. (Garvey 1998).	There would be only a very small dose, as 20 Ci is a 1/10 the inventory of the RAD-05 accident, and the TA-35 source is further from the townsite than is the TA-21 source. The chemical inventories are small and therefore not modeled.

TABLE G.5.4.4-4—Final Vulnerability and Consequence Assessment of Building Wildfires-Continued

TECHNICAL AREA	BLDG. NO.	FACILITY NAME	COMMENTS	SWEIS ASSESSMENT
TA-41	4	Experimental Science Laboratory Building	Approximately 0.02 g tritium (about 200 Ci) as residual contamination.	The RAD-05 aircraft crash and fire accident consequences from a 200 g release of tritium in oxide form at TA-21 were 24 person-rem population exposure and mean MEI dose of 0.012 rem at Route 502 (360 m).
TA-43	1	Health Research Laboratory	30 liters formaldehyde Information from facility walkdown conducted by GRAM, Inc. (Garvey 1998).	Evaluated in the SWEIS earthquakes. The ERPG-2 and ERPG-3 distances were 0.17 and 0.1 miles (0.27 and 0.16 km), respectively, under conservative daytime dispersion conditions. The number of people exposed to greater than ERPG-2 and ERPG-3 were 11 and 6, respectively.
TA-48	1	Radiochemistry Laboratory	See BIO for TA-48, approved 3/31/97.	Dissolving wing fire (Scenario 2) 0.3 mrem at 720 m, Alpha wing fire is 5.4 mrem at 720 m or at the Royal Crest Trailer Park. The whole facility fire is postulated to be 50 mrem. Chemical exposures at this location are less than ERPG-2.
TA-53	1	Laboratory Accelerator Building		Eliminated based on unavailability of the small inventory to wildfire, per walkdown provided by Chris Del Signore
TA-53	3	Linear Accelerator Building		Eliminated based on unavailability of the small inventory to wildfire, per walkdown provided by Chris Del Signore
TA-54	153, 224, 226, 229, 230, 231, 232, 283, 33, 48, 49, and Pad 2	Waste drum preparation, and domes	Evaluated in RAD-08.	The consequences of the aircraft-initiated fire in RAD-08 were 400 person-rem population exposure, and a mean MEI dose of 22 rem at both White Rock and Pajarito Road.

contains suspected inventories, pending verification.

Public Exposures from Burning Buildings.

Those building fires with integrated population and MEI inhalation exposure from burning buildings are also presented in summary Table G.5.4.4–5. Analyses already existed for some buildings in SARs and elsewhere in this SWEIS, such as the case for the aircraft crashes and fires in TA–21 and TA–54, identified as RAD–05 and RAD–08. The exposures assume no sheltering inside buildings or vehicles and that no protective actions are taken by the individual at those locations. Although Area G is not in the direct path of the fire, it borders a canyon and could be victim to a canyon fire even in the absence of a site-wide fire. Therefore, it also has been included in the wildfire analysis. The reader may evaluate the consequences of a partial site-wide wildfire and/or canyon fires by selecting individual canyons from summary Table G.5.4.4–2 and individual facilities from Table G.5.4.4–4 for summation.

Vulnerable buildings and the outdoors in the fire path were screened for their chemical inventories. No new inventories were found that were not available for the analysis of the site-wide earthquake (sections G.5.4.1 and G.5.4.2). For fire-vulnerable facilities, the earthquake chemical results were accepted for the site-wide fire, and entered into Table G.5.4.4–4. Note that, whereas the chemical releases in the earthquake were at ground level, the chemicals in the plume from the fire would be at higher elevations, and the concentrations at ground level would be much less.

Note that the meteorology used for dispersion in the different SARs and for the radiological accidents RAD–05 and RAD–08 in this SWEIS are not the same as that posed for this wildfire. The SARs use more conservative dispersion with low wind speed and stable conditions and will have a higher dose than if they had used

wildfire meteorology. The wildfire has significantly stronger wind and a neutral or unstable atmosphere, strongly affected by the fire itself. The SWEIS uses representative meteorology for an entire year and presents a mean MEI (section G.2.4). The representative meteorology includes winds blowing away from any receptor, and the full range of stabilities, weighted by frequency of occurrence. The wildfire meteorology would possibly result in the same dose to the MEI and population as does the mean meteorology because it may be close to the annually typical stability and wind speed. It was concluded that, due to the magnitude of the doses and the conservative assumptions in the wildfire scenario, and the uncertainty of the population distribution during the fire, new calculations were not warranted for RAD–05 and RAD–08.

There are no differences in wildfire frequency among the alternatives. The consequences do not vary with alternatives, except that the inventory and consequences are reduced by 25 percent in RAD–05 under the Reduced Operations Alternative.

Population Exposures

The following information on the exposed population is based upon the Los Alamos County Emergency Plan and the LANL Closure Plan (PC 1998f). In the event of a wildfire approaching from the south, LANL would begin evacuation of the southern area of LANL as soon as it was determined that the fire posed a threat, and proceed north with the evacuation. Personnel deemed essential to shutdown operations would remain until such actions were completed. Some emergency response personnel and security personnel would remain at all times in some areas. There are 10,200 LANL employees (including contractors), of which approximately 4,000 live outside of Los Alamos County and 6,200 within Los Alamos County. The main hill Road 502 will evacuate 800 cars per hour, and the combination of the

TABLE G.5.4.4-5—Consequence Summary for Building Fires

TECHNICAL AREA	BUILDING NUMBER	FACILITY NAME	SWEIS ASSESSMENT
TA-03	66/451	Sigma Building	The maximum dose calculated for this scenario was 3×10^{-5} rem 50 yr. committed effective dose equivalent (EDE) at approximately 10 km from the release point.
TA-16	205	Weapons Engineering Tritium Facility	The maximum dose (MEI) was calculated as 0.25 rem at 4.85-km distance. Doses are less at shorter distances due to the plume rise. The population dose is 189 person-rem within the 80.5-km (50-mile) radius.
TA-21	155	Tritium Science Test Assembly (TSTA)	Release of 200 grams of tritium oxide, resulting in population dose of 24 person-rem, and a mean MEI dose of 0.012 rem at State Road 502 (360 meters). These consequences are 25% less under the Reduced Operations Alternative.
TA-21	209	Tritium Science and Fabrication Facility	MEI dose of 0.006 rem at State Road 502 (360 meters) and 12 person-rem population dose.
TA-43	1	Health Research Laboratory	ERPG-2 and ERPG-3 distances are 0.17 and 0.1 miles (0.27 and 0.16 km) respectively. The number of people exposed to formaldehyde at greater than ERPG-2 and ERPG-3 are 11 and 6, respectively.
TA-48	1	Radiochemistry Laboratory	MEI dose from the entire building fire is 50 mrem at the Royal Crest Trailer Park. Chemical exposures at this location are less than ERPG-2.
TA-54	153, 224, 226, 229, 230, 231, 232, 283, 33, 48, 49, Pad 2	Waste Drum Preparation, and domes	Total population exposure 400 person-rem, and mean MEI of 22 rem at both White Rock and Pajarito Road.

East Jemez and Pajarito roads will evacuate another 800 cars per hour.

In a realistic scenario, evacuation of the town begins when the fire is well into the LANL site, but is impeded because of panic, accidents, and the very limited road system, including the closure of Pajarito Road. Some fraction of the population refuses to leave, and a significant number are relocated to the eastern edge of the town where there is less fuel load. Los Alamos has 11,500 residents, and White Rock has 8,000 residents. Los Alamos County estimates there are 2.4 people per family, and that 25 percent of the families will take two vehicles instead of one. It is accepted that the 6,200 LANL employees will all go home before evacuating the mesas. The 4,000 people living off the hill will take 1.25 hours to evacuate at two people per car in the absence of accidents. If all the employees go home first, the people living off of the hill may have cleared before the townsite begins. There would be 6,832 cars to leave the hill, which would take 4.3 hours. This is based on 2.4 people and the 25 percent extra vehicles. It should also be noted that up to 10 percent of the people might refuse to evacuate.

Because the differing population density as a function of time cannot be predicted, the results of the MACCS calculations must be presented as exposures to the same populations and receptors as used in the other accident analyses. Under the conservative assumptions applied in this analysis, the collective population dose from the wildfire consuming buildings is estimated to be about 625 person-rem. To this there may be added another 50 person-rem to capture the minor exposures from burning vegetation and from unidentified residual contamination in other buildings and vegetation. Most of this dose, about 75 percent, would come from the TA-54 Waste Management Complex. A population exposure of 675 person-rem would be expected to result in 0.34 excess LCFs.

Effects on Workers

All threatened workers would be evacuated prior to arrival of the fire front. Aircraft crashes with fatalities have occurred while dropping slurry on wildfires. Firefighters on the ground are at risk if they enter an area without an alternate escape route, and there have been historical fatalities from such events. However, because life safety is given first priority over protection of property at LANL, it is not likely that there will be worker fatalities. Some firefighters and other emergency personnel are likely to have significant but transient effects from smoke inhalation.

Ancillary Environmental Effects

Firewater. Firewater (water used in fighting building fires) at nonnuclear facilities is captured by outdoor containment and temporary dikes erected for fire fighting. Firewater at nuclear facilities is captured by the drain system and is sent to TA-50 for processing. Conceivably, some radioactively contaminated water could reach the outdoor environment, but would be of such small volume that it would not leave the building environs. Resultant contaminated soil would be eroded, pending the return of vegetative cover. As with other contaminated soils, the environmental and human health threat from the new contamination would be assessed and mitigated.

Loss of Protective Cover. The charred plant remains following a severe wildfire are the only immediate visual consequences. The consequences of a wildfire are diverse, continuing through time and space, and frequently having significant changes in geomorphology and biological communities and processes. LANL is perhaps unique in potential consequences, because in addition to a rich presence of biological communities and cultural remains and resources, there exists soil bearing legacy contaminants from historical operations.

Trees, grass and herbaceous cover, and forest litter are important features in stabilizing soils by: (1) reducing the velocity and impact of falling raindrops; (2) reducing the velocity of runoff, thereby encouraging infiltration and discouraging its transport by water and wind; and (3) reducing runoff quantities. Loss of vegetative cover will create a setting that can have pronounced effects on flow dynamics, soil erosion, and sediment deposition. These changes also can have significant ramifications for plant and animal communities and cultural resources.

Runoff, Soil Erosion, and Sedimentation.

Without a protective ground cover, runoff quantities and velocities will be magnified, and soil erosion by water and wind will begin immediately. Contributing to this condition will be the likely formation of an ash layer that will inhibit the infiltration of runoff. Decreased infiltration will increase the quantity and velocity of surface runoff, promoting higher channel volumes and watershed discharges. These higher runoff quantities will be discharged into the Rio Grande where they will contribute to the overall floodwater storage of Cochiti Lake. Modified hydrologic conditions likely will cause some watercourses that have only rarely had sufficient flows to reach the Rio Grande to increase their frequency of discharge.

Commensurate with higher runoff quantities and velocities will be an increase in soil erosion. Sheetflow will begin transporting soil suspended by rainfall droplet impact. Both rill and gullying will begin on sloping ground surfaces with the first significant rainfall event. Higher channel volumes and velocities will promote both downward and lateral scouring of channels in the steeper portions of the watershed and sediment deposition in the lower portions. (These conditions depend on quantity of runoff discharges and resulting changes in channel hydraulics.) Headcutting will increase throughout the channel system. Delta formation will increase at the confluence of watercourses tributary to the Rio Grande, and added sediment

will contribute to the depletion of the sediment reserve of Cochiti Lake.

The gradual establishment of ground cover will correspondingly retard soil erosion and a more stabilized hydrologic regime will return.

Effects on Legacy Contaminants. Active erosion processes have moved some contaminants bound to sediment from the watershed into the Rio Grande, mainly as suspended sediment and bedload sediment. Conversely, many of the remaining legacy contaminants at LANL are present in situ or have not been transported far from their origin or remain on site. Water transport is a major mechanism for the transport of contaminants both in the dissolved and suspended sediment phases. Because vegetation acts to hold soil and reduce erosion, its loss (however short term) may significantly increase the potential for erosion and the transportation of contaminants. Some water courses have only rarely had sufficient flow to reach the Rio Grande, and because of this they have become “discharge sinks” for some contaminants. Increases in runoff amounts and frequency will increase the potential to remove and transport contaminants from the ground surface and subsurface and stream channels on LANL into the Rio Grande and downstream to Cochiti Lake.

Effects on Biological Systems. Although fire is a natural part of biological systems, anthropogenic influences such as grazing, logging, and fire suppression have produced conditions that have pronounced adverse effects on forest ecosystems. Natural high-frequency, low intensity fire regimes have been replaced with low-frequency, high-intensity fires that consume a higher percentage of vegetation. As reflected in other nearby areas that have experienced severe wildfires in the past (e.g., Water Canyon, La Mesa, Dome, and Oso Complex fires), a wildfire at LANL will result in a period of disequilibrium with a reversion to early seral development and a corresponding change in animal use (Allen 1996). Fire debris,

fallen trees, and needle cast will gradually begin to check erosion and develop soil conditions that will promote the establishment of grasses and herbaceous vegetation that will in turn further reduce erosion. This gradual re-establishment of ground cover will begin the dynamic process of seral progression toward a wooded or forested plant community.

A loss of forest or woodland habitat will result in a temporary loss of habitat for a broad spectrum of animals. As vegetation is re-established an altered community of animal species will follow, its composition changing with the evolution of the plant community. The pattern of burned vegetation will play a significant role in renewed wildlife use. Early plant communities of grasses and herbaceous growth can have a high biomass and species diversity as exhibited by nearby areas affected by recent wildfires. This expansion of grass and herbaceous growth could provide additional forage for the large elk population in and around LANL and contribute to existing management concerns.

Impacts on threatened and endangered species (e.g., the Mexican spotted owl) will depend on several factors such as the burn pattern, the time of day that the burn occurs, the type of fire, topography, and if nesting is occurring. Threatened and endangered species have remained or returned to nearby areas that have experienced recent burns. Some species, such as the peregrine falcon, could benefit through improved foraging habitat. Individual response to fire also will vary. Perhaps the most significant impact to threatened and endangered species precipitated by a wildfire could be the general disturbance caused by the fire fighting effort itself (e.g., fire fighting crews, aircraft, and vehicular traffic).

As discussed previously, increased runoff discharges will result in a commensurate increase in channel scouring, enlargement, and headcutting. This process and any accompanying sedimentation will have the

potential to degrade or remove the limited riparian vegetation on LANL. Wetlands associated with water courses also would be affected, and perhaps several would be removed for a period of time because of changes in channel morphology. With the degradation of riparian vegetation and wetlands would be an associated reduction or loss of habitat for a variety of invertebrates, small and large mammals, amphibians, reptiles, and a diversity of birds.

Any impacts of contaminants transported to downstream riverine and lacustrine ecosystems is unknown, but there could potentially be an increase in ecological risk.

Effects on Cultural Resources. LANL is located in a region of abundant and culturally significant prehistoric and historic resources, including traditional cultural properties. As stated, fire is a normal feature of the landscape and has played and continues to play a natural role in the culture of regional communities. Because of anthropogenic influences, the character of recent fires will be different from historic fires and will affect resources differently. Also, the need to protect property and life from wildfire will necessitate measures that can affect cultural resources.

As discussed, high intensity fires can burn an appreciable amount of ground cover and accelerate erosion. Surface erosion can physically disturb surface features and confuse and distort the contextual integrity of the site. More pronounced erosion in the form of gully formation and lateral bank cutting can permanently remove site features. Also, a high intensity fire can scorch organic remains located near the ground surface, decreasing their interpretive value. Historical structures can suffer through direct incineration. Damage to these resources also can occur as a consequence of vehicular traffic and mechanical disturbance (e.g., bulldozers and fire trucks) and other soil disturbing activities connected with the firefighting effort.

Traditional cultural properties present on and adjacent to LANL include ceremonial and archaeological sites, natural features, ethnobotanical sites, artisan material sites, and subsistence features. These resources are an integral part of the landscape and almost certainly are and have been affected by natural fires. Because of the altered character of fires, these resources may be affected to a greater extent. Depending on the characteristics of these properties, they could either be permanently or temporarily affected by a wildfire and its subsequent ancillary effects (e.g., erosion).

Mitigation

The next fire season begins in April 1999. As a result of the process of this accident analysis, actions were initiated to reduce the wildfire risk to major facilities with significant radiological inventories. Specifically, considerations were given to reducing the risk to low or very low for the following facilities:

- TA-3 Building 66/451, Sigma
- TA-54 (Area G) Pads
- TA-21 Building 209, Tritium Science and Fabrication Facility (TSFF)
- TA-21 Building 155, Tritium Storage and Test Assembly (TSTA)
- TA-16 Building 205/205A, Weapons Engineering Tritium Facility (WETF).

Nevertheless, the public exposure from these specific facilities has been included in this wildfire analysis. With the completion of these actions, the population dose from site-wide wildfire would be reduced from an estimated 675 person-rem to 50 person-rem, with associated 0.25 excess LCF. In addition, although no credit is taken for it in this analysis, the long-term environmental restoration of contaminated sites will reduce airborne nuclides suspended by vegetation fires over those sites.

There also is an ongoing, interagency, collaborative program to reduce the threat of

catastrophic wildfire from occurring at LANL and the townsite by thinning and removing vegetation at the perimeter and in the surrounding Santa Fe National Forest and Bandelier National Monument. This will reduce the frequency and intensity of wildfires that could impinge on LANL.

Uncertainties

The frequency of wildfire impinging on LANL was estimated as 0.1 per year under the current fuel conditions in the surrounding forest and perimeter. This frequency includes wildfires approaching from the north through west and south. When fire enters LANL or originates from within LANL, there are numerous credible scenarios, most of which consume less of the LANL area than is covered in this analysis. Specifically, this analysis presumes that the fire jumps the Pajarito Road or any other established control line, spots or otherwise burns into all contaminated canyons, and successfully climbs canyon walls to ignite combustible buildings with moderate and higher wildfire vulnerability. The frequency of such a site-wide fire is surely less than 0.1 per year. The consequences of a complete burning of the western portion of LANL are presented in accord with the conservative nature of this SWEIS as a whole.

The plume rise calculated by OBODM in the canyon fires is likely to be much less than that which would actually occur resulting in lower doses at a distance of 330 and 3,300 feet (100 and 1,000 meters). This analysis used only the heat content of the fuel over the contaminated area; whereas, there is much fuel to the sides of the fire, and the combined heat would loft the plume thousands of feet. The observed convection columns in the past major forest fires would carry most contaminants far above the breathing zone of downwind individuals.

The wind speed used for dispersion of airborne material from the contaminated site fires was only 2 meters per second, which is probably less than would occur during a wildfire. The doses

are inversely proportional to the wind speed, such that if the observed wind were 6 meters per second, the dose would be 1/3 that calculated.

The fraction of the suspended contaminant that is respirable (less than 10 micrometers equivalent aerodynamic diameter) is unknown. According to Section D.5 of the DARHT EIS, the uranium in the soil is not all respirable. The particle size of the airborne soil contamination is likely to be large because the contaminants will be attached to soil particles preceding the fire and to soil and smoke particles in the plume. Because the airborne contaminant particle size is unknown, an RF of 1.0 is assumed. This is very conservative.

The White Rock and Santa Fe population is included in the MACCS calculations. The additional MACCS calculations for WETF and Sigma made for this wildfire analysis used the winds observed June 7 to 10, 1998, which are toward the Los Alamos townsite; whereas, the previous calculations for the other facilities used representative annual meteorology from 1995 (as described in section G.2.4). Because population is not evenly distributed about these sources, there would be a difference in the integrated population dose (i.e., in the person-rem) depending upon the meteorology used. Because the source inventories at the buildings vulnerable to wildfire do not vary significantly among alternatives, this does not affect the decision. (The inventory at TSTA is reduced by 25 percent under the Reduced Operations Alternative.)

The model calculations for dispersion of the plumes, for canyon sources several and more kilometers long, are most uncertain. The source was input as a volume having the dimensions of the width and length of the contaminated area, oriented along the axis of the wind direction. Differences in concentrations downwind are noted if the source is entered as a volume source versus a line source. The model also objects to a burning time longer than 60 minutes, and was manipulated into accepting these extensively

long volumes and longer burn times. The 60-minute limitation in the model is likely intended to prevent the user from exceeding the bounds of experimental data, most of which is for 10 to 30 minute releases. There are no field experiment data to which the canyon results can be compared. However uncertain, the radiological exposures predicted for the canyon fires are orders of magnitude less than the 100 mrem annual limit for public exposure from routine releases.

It has been estimated that there would be 50 person-rem from burning of buildings with residual contamination and from identified and unidentified contaminated soil/vegetation areas. This is a number not supported or disputed by hard data, and is believed to be very conservative.

There are no release fractions available for radionuclides other than plutonium and uranium. For consistency only, the ARF x RF of 4×10^{-4} for uranium was also used for plutonium, americium, and cesium in contaminated soils, which is conservative for plutonium by a factor of 7, and therefore, overestimates the bounding doses for mixed nuclides and TRU in Table G.5.4.4-2 by this factor.

There is no ready evidence that burning of the vegetation over the firing sites would produce detectable airborne DU. The U.S. Army tested DU projectiles at the Jefferson Proving Ground, releasing 50 metric tonnes of uranium in a 4 year period, of which 45.5 metric tonnes were not recovered from the area. Special samples showed that most of the DU was on or near the surface. The vegetative undergrowth was regularly controlled through burning, at which time high volume particulate air samples were collected. Analyses of the air samples did not detect any DU (Abbott 1988). For DU munitions in an intense wood-fuel oil fire burning for 2 hours, no airborne DU was collected in the air samplers at various distances out to 328 yards (100 meters), and 0.01 of

residual oxides was in the respirable size range (DOE 1994d).

The MEI and population doses do not take credit for sheltering in vehicles or buildings, which will easily reduce doses to 1/2 to 1/20 of that outdoors (Engelmann 1990, Engelmann et al. 1991). It should be noted that airborne contamination will be in the smoke, which people are inclined to avoid.

About 400 person-rem, or 75 percent of the total population exposure of 675 person-rem, results from a wildfire at TA-54. The results from RAD-08, an aircraft crash-initiated fire at TA-54, were used for the wildfire. The two fires would be quite different, one entailing aircraft fuel that will challenge waste containers. At present, the combustible loading within the dome structures is small, so that RAD-08 results very conservatively bound the consequences of a wildfire at TA-54.

Another 189 person-rem results from total release of the tritium inventory at WETF, including 1,260 grams in storage, which is assumed to bound an increased administrative limit that may be established. The storage containers are resistant to fire, but have been assumed to release their entire content in tritiated water form, in accord with the highly conservative nature of this analysis.

G.5.5 Chemical Accidents

G.5.5.1 *CHEM-01, Single Cylinder Release of Chlorine from Potable Water Chlorinator*

General Scenario Description

Accident scenario CHEM-01 postulates a chlorine gas leak from a single cylinder at a potable water chlorination station. The accident is initiated by equipment failure or human error during chlorine cylinder replacement or maintenance activities at the chlorinator station.

Two, 150-pound chlorine cylinders are connected to the injector system, which adds a small amount of chlorine to the potable water system for purification purposes.

The scenario is modeled as occurring at TA-00-1109, which is a site in the town of Los Alamos north of the high school. This location is one of nine chlorinator sites located around LANL and the town; the other locations are TA-00-1110, TA-00-1113, TA-00-1114, TA-16-560, TA-33-200, TA-54-1008, TA-72-3, and TA-73-9. TA-00-1109 was selected as the modeling location based on its proximity to residential housing and special populations, and provides an upper bound estimate of the potential impacts to the public. (It should be noted that a study is being conducted by LANL to evaluate the conversion of the chlorinator systems from a gaseous chlorine system to a less hazardous MIOX system that hydrolyzes brine to produce chlorine on site. In addition, negotiations are in progress that could lead to the chlorinator system being turned over to Los Alamos County.)

CHEM-01 Release Mechanisms

Chlorine usage has been estimated for the four SWEIS alternatives, with an average of seven to nine cylinders used per year at each of the potable water chlorinator stations. The chlorinator system at TA-00-1109 is a sweetener station that actually uses only two to three cylinders per year. Hence, it is conservative to model the station use rate at seven to nine cylinders per year, depending on the alternative.

Three leakage rates were defined for this event. The smallest leak is essentially a pin-hole leak that would result from random equipment failures or human errors. The next leak considered as a valve failure, which would open a 0.25-inch (0.64-centimeter) diameter hole in the cylinder pressure boundary. Finally, a

random cylinder rupture was defined that would instantaneously depressurize the cylinder.

No Action Alternative Frequency Analysis

The frequency of these endpoints was calculated separately for hardware and human error initiating events. Random cylinder failure (leak or rupture), as well as failures of the packing, the pressure gage, or the vacuum regulator can result in a chlorine release. The equipment failure contribution to this scenario is quantified as follows:

$$F_{EQP} = (F_{RAND-LEAK}) + (F_{RAND-RUPT})$$

where:

F_{EQP} = Annual frequency of the scenario due to equipment failure

$F_{RAND-LEAK}$ = Frequency of random failure resulting in cylinder leakage

$F_{RAND-RUPT}$ = Frequency of random failure resulting in cylinder rupture

These terms are all random events with a general equation as follows:

$$F = (\text{rate/hr}) \times (8,760 \text{ hr/yr}) \times (\text{number of items})$$

These values are as follows:

$$F_{RAND-LEAK} = (2 \times 10^{-8}/\text{hr}) \times (8,760 \text{ hr/yr}) \times (4) = 7 \times 10^{-4}/\text{yr} \text{ (LARGE LEAK); for factor of 20 difference from rupture (Mahn et al. 1995 and LANL 1995c)}$$

$$F_{RAND-RUPT} = (1 \times 10^{-9}/\text{hr}) \times (8,760 \text{ hr/yr}) \times (4) = 3.5 \times 10^{-5}/\text{yr} \text{ (RUPTURE) (Mahn et al. 1995)}$$

The total equipment failure contribution to CHEM-01 can be evaluated as follows:

$$F_{EQP} = F_{RAND-LEAK} + F_{RAND-RUPT}$$

$$F_{EQP} = (7 \times 10^{-4}) + (3.5 \times 10^{-5})$$

$$F_{EQP} = 7 \times 10^{-4}/\text{yr} \text{ (LARGE LEAK)}$$

$$F_{EQP} = 3.5 \times 10^{-5}/\text{yr} \text{ (RUPTURE)}$$

The human error contribution to this scenario is quantified as follows:

$$F_{HEP} = H_{VALVE} + H_{LEAK}$$

where:

F_{HEP} = Annual frequency of human error-induced chlorine release

H_{VALVE} = Human error leading to chlorine tank valve failure (LARGE LEAK)

H_{LEAK} = Human error leading to chlorine leak (SMALL LEAK)

A large leak due to valve failure would require human error in cylinder handling such that a chlorine cylinder with the valve cap removed is dropped, striking the valve and causing the valve to shear off. Small leaks could be due to a variety of causes, such as failure to follow cylinder changeout procedures resulting in a leak at the cylinder valve packing, the injector connection, tubing, or the V-notch assembly.

H_{VALVE} is related to the number of times per year that a full chlorine cylinder is removed from storage, has its valve cap removed, and then is placed into operation or into standby. Estimates of chlorine consumption in 150-pound cylinders have been made for all four alternatives (Barr 1997).

It is assumed that chlorine cylinder usage is averaged out over the nine potable water chlorinators. The number of chlorine cylinders changed out annually is eight for the No Action and Greener Alternatives, nine for the Expanded Operations Alternative, and seven for the Reduced Operations Alternative.

The basic human error rate is estimated as 0.003 per demand (Swain and Guttman 1983). Considering that personnel performing chlorine

cylinder operations are aware of the hazards involved, that the hazard is very direct, and it is therefore reasonable to assume that extra caution is employed in the operation, and that the changeout process is governed by a written procedure that is required to be used, this value was reduced by a factor of 50 to 6×10^{-5} per demand. (The derivation of the factor of 50 is based on the human error probability for checking the status of equipment under normal conditions and the probability for checking the status of equipment when the status affects one's safety [Swain and Guttman 1983].) No recovery probability is assessed because once the cylinder is dropped there is no opportunity to recover the situation. For the No Action Alternative, the frequency of human error leading to a large leak as a result of valve failure is $8 \times (6 \times 10^{-5})$, or 4.8×10^{-4} per year.

The human error leading to a leak is assessed based on recent experience with cylinder changeout. One leak has occurred in the past 5 years. With nine chlorinators changing out an average of eight cylinders per year, this is one leak in the change out of $9 \times 8 \times 5$, or 360 cylinders, or a conditional probability of a leak of once per 360 changeouts, or 2.8×10^{-3} per changeout. With eight changeouts per year, this is a frequency of 2.2×10^{-2} per year.

Based on the above evaluation, the following frequencies are identified for the No Action Alternative:

- Rupture (large leak rate, complete release in less than 60 seconds; to be calculated) 3.5×10^{-5} per year (random rupture)
- Large Leak (1/4-inch hole corresponding to valve size) 1.2×10^{-3} per year = 4.8×10^{-4} per year (human error, dropped cylinder) + 7×10^{-4} per year (random leak)
- Small Leak (pin-hole type leak, rate to be calculated) 2.2×10^{-2} per year (human error, cylinder changeout/maintenance)

Expanded Operations Alternative Frequency Analysis

The Expanded Operations Alternative does not alter the configuration of the chlorinator system. The rupture frequency and the small leak frequencies will remain the same. The large leak frequency increases somewhat because the number of cylinders changed out annually increases from eight to nine. This results in a human error contribution of $9 \times (6 \times 10^{-5}) = 5.4 \times 10^{-4}$, plus the random leak rate of 7×10^{-4} per year, yielding a large leak rate of $(5.4 \times 10^{-4}) + (7 \times 10^{-4}) = 1.2 \times 10^{-3}$ per year.

Reduced Operations Alternative Frequency Analysis

The Reduced Operations Alternative does not alter the configuration of the chlorinator system. The rupture frequency and the small leak frequencies will remain the same. The large leak frequency decreases somewhat because the number of cylinders changed out annually decreases from eight to seven. This results in a human error contribution of $7 \times (6 \times 10^{-5}) = 4.2 \times 10^{-4}$, plus the random leak rate of 7×10^{-4} per year, yielding a large leak rate of $(4.2 \times 10^{-4}) + (7 \times 10^{-4}) = 1.1 \times 10^{-3}$ per year.

Greener Alternative Frequency Analysis

The Greener Alternative does not alter the configuration of the chlorinator system; all release frequencies are the same because the cylinder changeout rate is the same. The frequencies of occurrence for CHEM-01 are considered to be bounding and conservatively take no credit for the frequency of time that some of the chlorine cylinders stored in the building may be empty.

Source Term Calculations

The initial source term for the postulated accident equals the contents of one filled chlorine cylinder (150 pounds). Due to the physical form of the hazardous material (gas), there is no suspension source term contribution

to the release. Because the cylinder size and system configuration do not vary across the alternatives, the source terms are the same across the alternatives. In all three cases (rupture, large leak, and small leak), the release is modeled as a ground level release. This is conservative because the release, especially in the case of smaller leak rates, could be released via the building exhaust system, which would result in an elevated release.

The smallest size hole with which the ALOHA™ code can perform release calculations is 0.0394 inch (0.1 centimeter) in diameter. Because this release occurs from a building, in accordance with EPA guidance the release rates are multiplied by 0.55 to correct for mixing within the building. For winter and summer conditions, this results in release rates from the building of 0.122 pound per minute and 0.181 pound per minute, respectively. Total releases within an hour total only 4 and 6 pounds of chlorine for winter and summer conditions, respectively.

For the large leak scenario, a release rate was estimated by conservatively assuming a direct release of the cylinder contents, and the same 0.55 in-building factor was applied, yielding a release rate of 8.25 pounds per minute for 18.2 minutes.

Uncertainties and Sensitivities Affecting the Source Term for CHEM-01

Not all chlorine cylinders that are dropped and result in valve failure would release 150 pounds of chlorine (some would be empty or nearly so). Random failure (rupture) of a chlorine cylinder could potentially cause failure of one or more adjacent cylinders. The source term estimates above do not consider such factors. To bound the possible consequences of a process-related chlorine release from the potable water chlorination system, the assumption is made that the cylinder is full and that the release cannot be terminated once it starts. Although this is a conservative assumption, it is consistent

with the approach taken in the TA-55-4 SAR (LANL 1996k) for a process-related release from a chlorine system that also uses 150-pound cylinders.

Consequences of CHEM-01 for Facility Workers and the Public

The consequences of CHEM-01 are presented separately for workers and the public. For workers, the following consequences are identified.

For the cylinder rupture accident, the likelihood of a worker being present is very low (the failure happens at random, rather than as a result of worker activity). Accordingly, no worker consequences would be expected under most conditions for cylinder rupture because workers would be present at the facility for a limited number of hours per month. Any workers present in the building would likely be killed due to the very high concentrations of chlorine that would result from cylinder rupture, as well as from the lack of time to escape from the immediate area before potentially lethal exposures would occur. Death to workers inside the building could also occur as a consequence of missiles (flying debris) generated when the cylinder ruptures.

For the large leak scenario, the workers present in the building (for the nonrandom failure part of the term) could be killed due to the high chlorine concentration in the building and/or the possibility of being struck by a missile (either the cylinder or the valve).

For the small leak scenario, injury seems to be a more likely outcome than fatality for facility workers. This is borne out by operating experience.

The public consequences for the small leak scenario are negligible (no ERPG-2 or ERPG-3 concentrations beyond 100 yards [92 meters]) regardless of the time of day, time of year, and even considering very adverse dispersion leading to a very stable, nonmeandering plume.

If the direction of the plume were to remain constant for the small leak scenario, nearby residents might detect the chlorine release by odor; however, even the ERPG-1 value of 1 parts per million would not be reached outside 100 yards (92 meters) from the facility under a conservative daytime dispersion condition (2.8 meters per second wind, Stability Class C). Under adverse (stable atmosphere) dispersion, the ERPG-1 distance could extend as far as 236 yards (216 meters). Given these results, no detailed quantification of the small leak scenario is carried forward.

For the large leak rupture scenarios, the release rate is of course much greater. For the large leak scenario, equivalent to a ruptured cylinder valve, the release rate is 2.2 to 3.8 pounds per minute (variable depending on time of year). Under adverse (stable atmosphere) dispersion, the ERPG-2 distance is 0.6 mile (1 kilometer), while the ERPG-3 distance is 0.2 mile (0.3 kilometer). Under conservative daytime dispersion, the ERPG-2 distance varies from 0.16 to 0.26 mile (0.26 to 0.42 kilometer), while the ERPG-3 distance varies from 0.06 to 0.09 mile (0.1 to 0.14 kilometer). The average number of people exposed at concentrations greater than ERPG-2 and ERPG-3 under adverse dispersion is 81 and 30, respectively, and for ERPG-2 and ERPG-3 under conservative daytime dispersion about 43 and 12, respectively.

For the rupture scenario, ERPG-2 concentrations reach a distance of about 1,600 yards (1,464 meters) under adverse dispersion (stable atmosphere) and a distance of about 500 to 700 yards (458 to 641 meters) under conservative daytime dispersion. ERPG-3 distances are about 450 yards (412 meters) under adverse dispersion and about 200 to 250 yards (183 to 229 meters) under conservative daytime dispersion. The average number of exposed people exposed to concentrations greater than ERPG-2 and ERPG-3 under adverse dispersion is 226 and 180, respectively, and about 53 and 12,

respectively, under conservative daytime dispersion. A summary of CHEM-01 results is presented in Table G.5.5.1-1.

G.5.5.2 *CHEM-02, Multiple Cylinder Release of Chlorine from Gas Plant*

General Scenario Description

Scenario CHEM-02 involves a multiple-cylinder release of chlorine from TA-3-476. This building is an all-weather, prefabricated, "Apache" all-metal storage shed that is used to store chlorine cylinders (and other hazardous gas cylinders) prior to distribution to end users at LANL. TA-3-476 is located at the northwest corner of the Gas Plant (the main facility at the Gas Plant is TA-3-170), which is located along Eniwetok Road near the Sigma Facility (TA-3-66). The storage shed, which has an open metal grate at the bottom, rests on asphalt.

In addition to chlorine, other extremely toxic gases that have in the past been temporarily stored at TA-3-476 include phosgene, arsine, phosphine, and fluorine. Such gases are typically present 1 day or less per year per gas. Some quantity of chlorine is present essentially all the time. The release of the largest single container of these gases has been modeled in the Safety Assessment under adverse dispersion conditions (Class F stability, wind speed of 3.3 feet [1 meter] per second) and compared with a 150-pound chlorine cylinder release. The distances to which ERPG-2 and ERPG-3 exposures could be experienced were the largest for the chlorine cylinder release.

The frequency of release of gases other than chlorine would be directly proportional to the conditional probability of their presence at the facility. Accordingly, it has been determined that the risk of a release of chlorine from TA-3-476 bounds the risks of release of other toxic gases both in frequency of occurrence and in the consequences of the release.

The CHEM-02 accident scenario involves a release of chlorine gas, which is conservatively assumed (with respect to exposure at short distances) to occur at ground level, followed by dispersal of the gas downwind. The release is also conservatively modeled as involving simultaneous release from multiple cylinders. In fact, the cylinders may not all release at the same time, in which case the downwind concentrations would be less, and there would be less chance of exceeding the thresholds for health effects.

Properties of Chlorine Gas

Chlorine is a greenish-yellow gas or liquid. Chlorine is extremely irritating to the mucous membranes of the eyes and respiratory tract at a concentration of 3 parts per million. A concentration of 3.5 parts per million is detectable by odor. A concentration of 15 parts per million causes immediate irritation of the throat. Concentrations of 50 parts per million are dangerous for even short exposures, and concentrations of 1,000 parts per million may be fatal even when the exposure is brief (Lewis 1993). The ERPG-1, -2, and -3 concentrations are 1, 3, and 20 parts per million, respectively (Craig 1996). The pressure in a 150-pound chlorine cylinder is 0.588 MPa (85.3 psig) at a temperature of 70°F (21°C) (MGP 1997). Cylinders containing chlorine are equipped with a fusible metal plug with a melting temperature of 165°F (73.9°C) (Braker and Mossman 1980). In the event of a fire that exceeds this temperature, the fusible plug will melt, permitting the chlorine to escape but preventing the cylinder from catastrophically failing due to overpressure. Chemical reactions of chlorine of potential interest to this scenario include the reaction with carbon monoxide to form phosgene (carbonyl chloride, CCl_2O , a colorless poison gas) (Braker and Mossman 1980), and the reaction with ammonia causing an explosion (Lewis 1993).

Properties of a Heavy Gas

The release of chlorine from a pressurized cylinder will consist of a combination of droplets and vapor constituting a heavy, cold cloud full of small droplets that remain airborne and travel significant distances. The continuing evaporation of these droplets along the plume path virtually renews the strength of the cloud as it travels and keeps it cool and heavier than the ambient air. This has significant effects on the dispersion, and the standard Gaussian plume models are inappropriate; “heavy gas” models such as DEGADIS and SLAB must be used instead. The cloud can persist for substantially longer times than the spill duration, and plume travel time can be substantially longer than would be expected from the wind speed. When the concentration of the chlorine falls to a value such that the cloud density is similar to that of the air, it no longer acts independently of the air as a heavy gas, but behaves as a passive tracer. The concentration at which this occurs depends upon the wind speed and height of the cloud (which in turn depends upon the size of the release). When the wind is 3.3 feet per second (1 meter per second) and the chlorine cloud is 33 feet (10 meters) high, the change from heavy gas to passive behavior occurs at about 280 parts per million. This is substantially greater than the ERPG-3 of 20 parts per million and produces serious health effects. For this reason, protection from a chlorine release is not assured by intervening canyons.

CHEM-02 Release Mechanisms

Three potential release mechanisms were identified and subjected to detailed analysis. Release by direct impact of a vehicle on the stored cylinders was screened out based on the presence of vehicle barriers in front of and to the sides of the storage shed, the inability of a vehicle to approach the shed from behind (an arroyo is located behind the shed), and the administrative controls on speed limits at the Gas Plant (along with the DOT training and LANL-specific training of truck drivers at the

plant). Two other release mechanisms were considered for their contribution to the frequency of CHEM-02: (1) a truck fuel fire, resulting in failure of the chlorine cylinders; and (2) the impact of an aircraft on nearby hydrogen tube trailers, resulting in failure of multiple chlorine cylinders due to overpressure, impact by missiles (shrapnel created by the detonation of hydrogen tubes upon impact by the aircraft), or fire.

This accident was not analyzed in the Gas Plant Safety Assessment (LANL 1994b). The safety assessment (SA) screened all multiple cylinder release scenarios as being incredible (i.e., having frequencies less than 10^{-6} per year). The most severe scenario analyzed in the SA was a single cylinder release of chlorine (see CHEM-03, section G.5.1.6). The SA concluded that the installation of the vehicle barrier around TA-3-476 eliminated the possibility of a multiple cylinder release. While this appears to be a valid conclusion insofar as direct vehicular impact with the chlorine cylinders is concerned, it is not clear that the SA considered a fuel fire for which the vehicle barriers would be ineffective.

No Action Alternative Frequency Analysis

The fuel fire and aircraft crash contributors are analyzed separately. In the case of a fuel fire, a truck accident near TA-3-476, or one impacting the vehicle barrier around TA-3-476, could result in a failure of the truck fuel system or the fuel tank(s), resulting in a spill of diesel fuel. Second, a truck parked near TA-3-476 could experience a fuel system leak or fuel tank leak due to causes unrelated to a vehicle accident. In either case, once a fuel leak occurs, ignition of the spilled fuel would lead to a fire that, if it is close enough to TA-3-476 and it is not suppressed, would result in damage to the chlorine cylinders and a release of chlorine to the environment.

There are no automatic means of fire detection or fire suppression installed at TA-3-476,

although there is a fire hydrant located within 164 feet (50 meters) of TA-3-476 where fire hoses could obtain water for fighting the fire. Manual fire fighting equipment (extinguishers) is provided at TA-3-170. The response time of a fire brigade to TA-3-476 is estimated at 2 to 3 minutes; the fire station at TA-3-41 is within a kilometer of TA-3-476.

There are no physical barriers present that are capable of precluding a fire from reaching TA-3-476. There are concrete-filled metal tubes installed at the front of TA-3-476 to prevent the impact of a vehicle on the storage shed. While the barriers will essentially preclude direct vehicular impact with the cylinders, the barriers will have no effect on the propagation of a fuel fire (which could result from a ruptured fuel line/fuel tank as a consequence of impact of a vehicle with the vehicle barriers).

The frequency of the fuel leak and fire contributor accident can be estimated using the following equation:

$$F_{\text{FIRE}} = N_{\text{SHIPMENTS}} \times L \times F$$

where:

F_{FIRE} = Frequency of a fire at TA-3-476

$N_{\text{SHIPMENTS}}$ = Number of shipments to or from TA-3-476 per year

L = Fuel leak rate per shipment

F = Conditional probability of fire given a fuel leak and subsequent release of chlorine

The frequency of a fuel system leak or fuel tank leak and a resulting fire is assessed for TA-3-476 based on methods and data contained in the TA-54, Area G Hazard Analysis (LANL 1995g) and the evaluation of TRU waste transportation by H&R Technical Associates (Rhyne 1994). The annual frequency of a fuel leak was assessed at 0.1 per year in the TA-54 hazard analysis

(LANL 1995g). Embedded in this estimate is 78 trips per year of trucks to the facility. Thus, on a per trip basis, the likelihood of a fuel leak is 0.1/78, or 1.3×10^{-3} per trip.

The TA-54 hazard analysis (LANL 1995 through 1997) cites data from Rhyne 1994 to the effect that the conditional probability of a fire given a fuel leak is 4.7×10^{-3} per fuel leak. Although the direct applicability of this value is open to interpretation, the value is used in CHEM-02, RAD-01, and RAD-07 because no other comparable value could be identified and because DOE believes the value to be conservative.

The TA-54 hazard analysis recommended an additional frequency reduction by a factor of ten compared with the H&R evaluation due to the fuel being diesel (LANL 1995g). However, the H&R evaluation already takes into account the fact that the transport vehicle is a flatbed truck, which is a diesel fuel vehicle (Rhyne 1994). Accordingly, this additional factor of ten reduction in conditional probability was not employed here.

Site-wide usage of chlorine has been estimated across the alternatives in Table G.5.5.2-1. The number of shipments to or from TA-3-476 per year for the No Action Alternative is estimated based on the sum of shipments from the chlorine supplier to TA-3-476 and shipments from TA-3-476 to the potable water chlorination stations in and around LANL. During the walkdown of TA-3-476, it was stated that there were two shipments per year from the chlorine supplier. However, this information is inconsistent with the number of 150-pound chlorine cylinders estimated to be used annually.

The data in Table G.5.5.2-1 was interpreted by dividing the 150-pound cylinder usage by 150 pounds to obtain the approximate number of cylinders used annually. This value is shown in the last row of Table G.5.5.2-1. Because only ten full chlorine cylinders are permitted to

be in TA-3-476 at any one time (LANL 1997b), the number of trips was approximated by dividing the number of cylinders used annually by ten (the number of cylinders allowed to be at TA-3-476). The number of supplier shipments is thus seven per year for all alternatives except Expanded Operations, where the number of supplier shipments is eight.

The number of shipments from TA-3-476 to potable water chlorinators is 14 per year (based on shipments of no more than 5 cylinders at a time and a total of 70 cylinders needed per year). The total number of shipments is therefore 7 plus 14, or 21.

The frequency equation can be solved as follows for the No Action Alternative:

$$F_{\text{FIRE}} = N_{\text{SHIPMENTS}} \times L \times F$$

$$F_{\text{FIRE}} = 21 \times (1.3 \times 10^{-3}) \times (4.7 \times 10^{-3})$$

$$F_{\text{FIRE}} = 1.3 \times 10^{-4}/\text{yr}$$

As noted above, fuel fires also can occur as a result of a truck accident near TA-3-476 or as a result of an impact of a vehicle with the vehicle barrier immediately in front of TA-3-476. The general accident rate for highway traffic is 1×10^{-6} per mile (Fenner 1996). Data on which the RADTRAN transportation accident code is based show that only 29 percent of all accidents occur at speeds of 20 miles per hour or less (Clarke 1976), which is what would be expected at the Gas Plant because the speed limit is 15 miles per hour (allowing for some margin over this value, 20 miles per hour was selected as a quantification basis). Thus, the accident rate should be $(1 \times 10^{-6}) \times 0.29 = 2.9 \times 10^{-7}$ per mile. Even if the distance from the Gas Plant security gate to TA-3-476 is used for quantification, this is a distance of approximately 220 feet (67 meters) or 0.042 miles. The accident rate per trip is thus $21 \text{ trips/yr} \times 0.042 \text{ miles/trip} \times (2.9 \times 10^{-7} \text{ accidents/mile}) = 2.6 \times 10^{-7} \text{ accidents per year}$. Even allowing that there are trips near

TA-3-476 not involving chlorine shipments, there would have to be thousands of such shipments before this contributor would begin to compete probabilistically with the fuel leak/fire scenario quantified above. Moreover, each shipment would have to pass sufficiently near TA-3-476 such that the fire, if it occurred, actually reached the chlorine cylinders stored in that building. Accordingly, this potential accident contributor was screened out.

Evaluation of Hydrogen Tube Trailer Failure

During the physical inspection (walkdown) of the Gas Plant and during subsequent visual spot checks, there have been four or five hydrogen tube trailers parked within 164 feet (50 meters) of TA-3-476. Gas Plant management states that typically half of the trailers are empty and half are full (Lovato and Nielsen 1997). The trailers are typically located within less than 164 feet (50 meters) of TA-3-476.

In the event of a catastrophic tube trailer failure (rupture of tube or tubes, detonation of hydrogen), there are no physical barriers that could preclude overpressure or missile impact from reaching TA-3-476. The outer shell of TA-3-476 is simply sheet metal, which would offer very little resistance.

A tube on a hydrogen tube trailer failed catastrophically at TA-3-170 in June 1981. There was no effect on TA-3-476 as a result of that accident, and the tube failure did not propagate to the entire tube trailer. While the specific scenario that occurred in June 1981 is no longer considered to be credible (the process that caused the accident is no longer performed at the facility), the hydrogen tubes could fail due to other causes.

The tube trailers are DOT Type 3AA trailers with 38 tubes per trailer. The trailers are 22 feet (6.7 meters) long. Each tube trailer holds 50,000 standard cubic feet of hydrogen gas (261.37 pounds of hydrogen). In order to

evaluate the consequences of the catastrophic failure of an entire tube trailer, a simple TNT equivalent calculation was performed. In accordance with standard practice involving calculations of explosive yield for design purposes, a 20 percent safety factor was applied to the calculation. Assuming 100 percent explosive yield is grossly conservative. In accordance with recommendations by the American Institute of Chemical Engineers, a 15 percent conversion factor was used (AICE 1994). The estimated explosive yield (in TNT equivalent) was calculated to be about 965 pounds. This amount of TNT was found to be insufficient for a 10-psi overpressure to reach TA-3-476, and it was concluded that random failure of a single tube trailer could not cause a chlorine release.

Calculations of aircraft crash frequency have been performed according to the methodology in DOE Standard 3014-96 (DOE 1996c). The width of the "target" was increased to account for the chlorine storage shed itself (TA-3-476) as well as the hydrogen tube trailers. This was done to account for the possibility that the aircraft would impact the tube trailers, causing a detonation of one or more tube trailers. The resulting crash frequency was calculated to be 2.0×10^{-7} per year.

The frequency of occurrence for CHEM-02 is the sum of the frequency of the contributing means of occurrence:

$$F_{\text{TOTAL}} = F_{\text{FIRE}} + F_{\text{AIR}}$$

where:

F_{TOTAL} = Total scenario frequency

F_{FIRE} = Frequency from vehicle fires

F_{AIR} = Frequency from aircraft crash

This equation can be evaluated as follows:

$$F_{\text{TOTAL}} = F_{\text{FIRE}} + F_{\text{AIR}}$$

$$= (1.3 \times 10^{-4}) + (2.0 \times 10^{-7})$$

$$= 1.3 \times 10^{-4} \text{ per year}$$

Expanded Operations Alternative Frequency Estimate

The only change in circumstances affecting the frequency of CHEM-02 compared with the No Action Alternative is the frequency of shipments to or from TA-3-476 for the vehicle fuel fire scenario. For the Expanded Operations Alternative, the number of shipments increases from 14 to 16 per year due to a higher rate of chlorine consumption for potable water use. In addition, the number of shipments from the chlorine supplier increases from seven to eight per year. The total number of shipments is thus 24, and the frequency of the vehicle fuel fire contributor can be estimated as follows:

$$F_{\text{FIRE}} = N_{\text{SHIPMENTS}} \times L \times F$$

$$F_{\text{FIRE}} = 24 \times (1.3 \times 10^{-3}) \times (4.7 \times 10^{-3})$$

$$F_{\text{FIRE}} = 1.5 \times 10^{-4}$$

The summed frequency for all contributors becomes:

$$F_{\text{TOTAL}} = F_{\text{FIRE}} + F_{\text{AIR}}$$

$$F_{\text{TOTAL}} = (1.5 \times 10^{-4}) + (1.3 \times 10^{-6})$$

$$F_{\text{TOTAL}} = 1.5 \times 10^{-4} \text{ per year}$$

Reduced Operations Alternative Frequency Calculation

The only change in circumstances affecting the frequency of CHEM-02 compared with the No Action Alternative is the frequency of shipments to or from TA-3-476 for the vehicle fuel fire scenario. For the Reduced Operations Alternative, the number of shipments decreases from 16 to 13 per year due to a higher rate of chlorine consumption or potable water use. The number of shipments inbound from the chlorine supplier remains at seven. Thus, the frequency

of the vehicle fuel fire contributor can be estimated as follows:

$$F_{\text{FIRE}} = N_{\text{SHIPMENTS}} \times L \times F$$

$$= 20 \times (1.3 \times 10^{-3}) \times (4.7 \times 10^{-3})$$

$$= 1.2 \times 10^{-4}$$

The summed frequency for all contributors becomes:

$$F_{\text{TOTAL}} = F_{\text{FIRE}} + F_{\text{AIR}}$$

$$= (1.2 \times 10^{-4}) + (2.0 \times 10^{-7})$$

$$= 1.2 \times 10^{-4} \text{ per year}$$

Greener Alternative Frequency Calculation

The frequency of shipments to or from TA-3-476 is the same for the Greener Alternative as it is for the No Action Alternative. Thus, the summed frequency of all contributors of 1.3×10^{-4} per year applies to the Greener Alternative as well.

Uncertainties and Sensitivities Affecting the Frequency of CHEM-02

The accident frequency calculations reported above do not account for the possible suppression of the fire by Gas Plant personnel or the fire department (TA-3-41) prior to the failure of the chlorine cylinders. Thus, the frequencies calculated above for the fuel fire contributor to the accident frequency represent overestimates, but given the reporting time for the fire brigade (2 to 3 minutes) and the low melting temperature of the fusible plugs on the chlorine cylinders (165°F [73.9°C]), this conservatism is not considered to be substantial.

The frequency calculations for the fuel fire contributor are sensitive to the inferred rate of fuel failures per shipment (to or from the facility) and to the conditional probability of a fire given a fuel leak. The likelihood of a fire given a fuel leak is based on vehicle accident

data that include vehicle speeds of up to highway speeds. In contrast, the speed of vehicles around the Gas Plant is limited to much lower speeds. Because it would seem reasonable to assume that the likelihood of a fuel leak given an accident bears some relationship to the speed of impact (or overturning), the conditional probability of a fire given a fuel leak may be unduly pessimistic. Because an alternative value could not be identified, this admittedly pessimistic value was used in the calculations.

Source Term Calculations

The administrative limit on the number of full chlorine cylinders that can be located at TA-3-476 is eight cylinders. This limit can be exceeded for a maximum of three days by procedure on a temporary basis (LANL 1997b and Lovato and Nielsen 1997). Note that a number of cylinders in excess of ten would bring the total chlorine inventory in TA-3-476 to over 1,500 pounds. Under OSHA Standard 1910.119, Appendix A, 1,500 pounds or more of chlorine are considered to present a potential for a catastrophic event. Therefore, consequence estimates have been prepared using 1,500 pounds of chlorine. This quantity will be conservative by at least 300 pounds under most conditions. This source term is used across all alternatives.

The release was modeled as a direct release, with a constant release rate for 10 minutes based on sensitivity calculations and discussions with the code authors. The release is modeled as originating with a single cylinder that numerically represents the effective release rate of ten, 150-pound cylinders. The release is assumed to occur as a result of the melting of fusible plugs on the cylinder, which melt at 165°F (73.9°C).

Uncertainties and Sensitivities Affecting the Source Term for CHEM-02

The assumption of a ground level release is conservative with respect to chlorine gas

concentrations close to TA-3-476 (such as at the TA-3 administrative complex). Indeed, the assumption of a ground level release is not realistic because the release is caused by a fire, whose heat would elevate the plume above ground level. A ground level release will produce higher concentrations at breathing level than the expected elevated release.

Consequences of CHEM-02 for Facility Workers and the Public

Workers at TA-3-170 could be exposed to concentrations greater than ERPG-2 and ERPG-3 if they are downwind. Because Gas Plant workers will be closest to the accident site, the plume will be dense and will probably be visible during the period of the greatest release. The workers could escape from the plume on foot provided they do not become immersed in the plume (in which case they would encounter very high chlorine concentrations). Workers attempting to fight the fire without an air supply could be overcome by chlorine gas. (Workers are directed not to fight fires but instead to call the fire department and evacuate the area.)

Under adverse dispersion conditions (light wind, stable plume), ERPG-2 concentrations are exceeded out to distances ranging from 2.6 to 2.7 miles (4.2 to 4.3 kilometers), while ERPG-3 concentrations are exceeded out to distances of 1.1 to 1.2 miles (1.8 to 1.9 kilometers). Under conservative daytime dispersion, ERPG-2 concentrations are exceeded out to distances ranging from 1.2 to 1.4 miles (1.9 to 2.3 kilometers), while ERPG-3 concentrations are exceeded to distances ranging from 0.57 to 0.66 mile (0.92 to 1.1 kilometer). Average numbers of people affected by these concentrations are shown in Table G.5.5.2-2, which summarizes the modeling results for CHEM-02. Note that this release occurs within the LANL boundary. The town of Los Alamos is separated from the release point by wide, deep canyons that would trap and steer the highest concentrations of the plume away from the town site. The average

number of people exposed is governed by numerous directions of release where no or few members of the public are located. If, however, the plume blows toward the most heavily populated area of TA-3 (which occurs less than 10 percent of the time), the number of people exposed to concentrations greater than ERPG-2 and ERPG-3 could number in the many hundreds to low thousands.

G.5.5.3 CHEM-03, Single Cylinder Chlorine Release from Gas Plant

General Scenario Description

Like CHEM-02, CHEM-03 occurs at TA-3-476. However, CHEM-03 involves the release of chlorine from a single 150-pound cylinder. This scenario was evaluated in the Gas Plant Safety Assessment (LANL 1994b). Three contributors were identified: (1) release without fire due to an on-site transportation accident at the toxic gas storage shed (Scenario 5), frequency from 10^{-4} to 10^{-3} per year; (2) release due to drop of toxic gas cylinder (Scenario 11), frequency from 10^{-4} to 10^{-3} per year; and (3) release due to deterioration of cylinders from weather (Scenario 23), frequency from 10^{-4} to 10^{-3} per year. The properties of chlorine gas and heavy gases were addressed in section G.5.1.5.

CHEM-03 Release Mechanisms

As noted above, three release mechanisms were postulated in the Gas Plant SA (LANL 1994b). Release due to impact of a cylinder by a truck is discounted here because of the installation of bumpers in front of the toxic gas storage shed, which was accomplished as a corrective action after the SA was performed. Chlorine releases from a single cylinder due to a dropped cylinder and due to long-term exposure to weather are addressed separately below.

No Action Frequency Analysis

Because all cylinders are stored with their valve covers installed (Lovato and Nielsen 1997), the scenario would have to involve a second human error in failing to install the valve cover correctly at the supplier facility. A third error would also be required because receipt inspections are performed and the status of the valve cover would normally be checked at this time.

On the basis of these considerations, the frequency of this contributor can be calculated using the following equation:

$$F_{\text{DROP}} = N_{\text{HANDLED}} \times H_{\text{DROP}} \times H_{\text{COVER}} \times \frac{H_{\text{CHK}}}{C_{\text{FAIL}}}$$

where:

F_{DROP} = Frequency of dropped cylinder resulting in chlorine release

N_{HANDLED} = Number of cylinders handled per year

H_{DROP} = Human error, dropping cylinder during handling

H_{COVER} = Human error, failure to install valve cover properly

H_{CHK} = Human error, failing to check valve cover installation during receipt inspection

C_{FAIL} = Conditional probability of valve failure when cylinder is dropped

The number of cylinders handled annually under the No Action Alternative is 70 based on the information presented above in section G.5.5.1. Each cylinder is handled twice (once during placement into TA-3-476 for storage and again during retrieval from storage). Thus, the total number of handling events is 140.

We estimate the basic human error rate as 0.003 per demand. Although perhaps not directly applicable to DOE facilities, a study of human reliability with emphasis on nuclear power plant applications supports this number (Swain and Guttmann 1983). Considering that the personnel handling the cylinder expect the valve cover to be installed, no additional credit is taken here for extra precautions that might be observed if the workers believed that their life would be endangered by mistakes. No recovery probability is assessed because once the cylinder is dropped there is no opportunity to recover the situation. The human error probability (HEP) for failing to install the valve cover properly is 0.003 (failure to properly mate a connector; Swain and Guttmann 1983). Failure to check the valve cover installation during receipt inspection is 0.1 (Swain and Guttmann 1983). The conditional probability of valve failure given that the cylinder is dropped with an improperly installed valve cover is judged to be no more than 0.25 because the cylinder can be dropped on the top, the bottom, or either side, and only dropping the cylinder on the top is judged to be associated with valve failure.

On the basis of these considerations, the above equation can be quantified as follows:

$$F_{\text{DROP}} = N_{\text{HANDLED}} \times H_{\text{DROP}} \times H_{\text{COVER}} \times \frac{H_{\text{CHK}} \times C_{\text{FAIL}}}{H_{\text{CHK}} \times C_{\text{FAIL}}}$$

$$= 140 \times 0.003 \times 0.003 \times 0.1 \times 0.25$$

$$= 3.2 \times 10^{-5} \text{ per year}$$

The Gas Plant SA identified failure of a cylinder due to deterioration from weather. This failure mode is essentially a random cylinder failure, especially considering that the cylinders are designed to be exposed to weather but are stored inside the toxic gas storage shed until they are picked up for shipment to the potable water chlorinator stations.

The frequency of random cylinder failure can be assessed as follows:

$$F_{\text{RANDOM}} = R_{\text{HOURLY}} \times (8,760 \text{ hr/yr}) \times N_{\text{CYL}}$$

where:

F_{RANDOM} = Frequency of random cylinder failure

R_{HOURLY} = Random failure rate per hour of a pressurized cylinder

8,760 hr/yr = The number of hours in a year

N_{CYL} = The number of cylinders in storage

The random failure rate for a pressurized cylinder is 1×10^{-9} per hour (Mahn et al. 1995). The number of cylinders in storage is ten full cylinders at any one time (Lovato and Nielsen 1997). Thus, the above equation can be quantified as follows:

$$F_{\text{RANDOM}} = R_{\text{HOURLY}} \times (8,760 \text{ hr/yr}) \times N_{\text{CYL}}$$

$$= (1 \times 10^{-9} \text{ /hr}) \times (8,760 \text{ hr/yr}) \times 10$$

$$= 8.8 \times 10^{-5} \text{ per year}$$

The combined frequency of occurrence of a single cylinder toxic gas release is obtained from the following equation:

$$F_{\text{TOTAL}} = F_{\text{DROP}} + F_{\text{RANDOM}}$$

$$= (3.2 \times 10^{-5}) + (8.8 \times 10^{-5})$$

$$= 1.2 \times 10^{-4} \text{ per year}$$

Expanded Operations Alternative Frequency Analysis

There is only one difference for the Expanded Operations Alternative that affects sequence frequency. In the Expanded Operations Alternative there are 79 cylinders handled per year, with a total of 158 handling events. The equation above for the cylinder drop scenario

can be reevaluated for the Expanded Operations Alternative as follows:

$$F_{\text{DROP}} = N_{\text{HANDLED}} \times H_{\text{DROP}} \times H_{\text{COVER}} \times H_{\text{CHK}} \times C_{\text{FAIL}}$$

$$= 158 \times 0.003 \times 0.003 \times 0.1 \times 0.25$$

$$= 3.6 \times 10^{-5} \text{ per year}$$

Because the frequency of random failure does not change, the combined frequency of occurrence of a single cylinder toxic gas release for the Expanded Operations Alternative is obtained as follows:

$$F_{\text{TOTAL}} = F_{\text{DROP}} + F_{\text{RANDOM}}$$

$$= (3.6 \times 10^{-5}) + (8.8 \times 10^{-5})$$

$$= 1.2 \times 10^{-4} \text{ per year}$$

Reduced Operations Alternative Frequency Analysis

There is only one difference for the Reduced Operations Alternative that affects sequence frequency. Based on the analysis of scenario CHEM-02 (Rev. 0, 04/08/97), there are 66 cylinders handled per year, with a total of 132 handling events. The equation for cylinder drop can be reevaluated as follows:

$$F_{\text{DROP}} = N_{\text{HANDLED}} \times H_{\text{DROP}} \times H_{\text{COVER}} \times H_{\text{CHK}} \times C_{\text{FAIL}}$$

$$F_{\text{DROP}} = 132 \times 0.003 \times 0.003 \times 0.1 \times 0.25$$

$$F_{\text{DROP}} = 3.0 \times 10^{-5} \text{ per year}$$

Because the frequency of random failure does not change, the combined frequency of occurrence of a single cylinder toxic gas release for the Expanded Operations Alternative is obtained as follows:

$$F_{\text{TOTAL}} = F_{\text{DROP}} + F_{\text{RANDOM}}$$

$$= (3 \times 10^{-5}) + (8.8 \times 10^{-5})$$

$$= 1.2 \times 10^{-4} \text{ per year}$$

Greener Alternative Frequency Analysis

The number of cylinders handled per year under the Greener Alternative is the same as the No Action Alternative. Thus, the frequency of a release of a single cylinder of chlorine gas is the same, or a frequency of 1.2×10^{-4} per year.

Uncertainties and Sensitivities Affecting the Frequency of CHEM-03

Because the number of cylinders handled per year and the number of trips per year are relatively well known, the principal uncertainties in the frequency of a single cylinder release of chlorine relate to the error factors for the human errors modeled. These error factors range from three to five (Swain and Guttman 1983). Even if an error factor of five were considered, the contribution to frequency of CHEM-03 would be about evenly split between the low-frequency human error leading to valve failure and the random failure of a cylinder.

Source Term Calculations

The available material for release in the CHEM-03 source term is limited to the complete contents of one chlorine cylinder, or 150 pounds. However, the release through the valve orifice is such that 68 to 75 pounds of chlorine release quickly; but, in the process the cylinder is cooled below the boiling point of the chlorine liquid remaining in the cylinder and the release is essentially terminated. If no recovery actions are taken, the cylinder would ultimately heat up above the boiling temperature of chlorine and a release would resume, but at a very low rate, which is unlikely to result in any health consequences downwind of the cylinder.

Uncertainties and Sensitivities Affecting the Source Term for CHEM-03

EPA Risk Management Program off-site consequence analysis guidance issued in 1996 indicates that when a toxic gas is released inside a building that has direct contact with the outside environment (such as a shed), the

release rate is ameliorated somewhat due to mixing within the shed. The guidance suggests multiplying the release rate by 0.55 (EPA 1996). The same quantity of gas is released, but the release duration is extended beyond what would be predicted by the ALOHA™ code. This reduction factor is not applied here because the release could also occur outdoors (human error dropping a cylinder).

Consequences of CHEM–03 for Facility Workers and the Public

Consequences of the CHEM–03 accident are reported separately for facility workers and the public. Gas Plant personnel who are directly involved in handling the cylinders of chlorine could quickly be exposed to high concentrations for the human error (cylinder dropping) contributor to the scenario frequency. In the case of the random cylinder failure contributor, however, it is more likely that no one will be near the toxic gas storage shed when the leakage begins. Other Gas Plant personnel located outdoors at the time of the accident could be exposed to concentrations greater than ERPG–2 and ERPG–3. However, these personnel would be in a position to evacuate the affected area very quickly (due to being outdoors), which would reduce the potential for serious health effects.

Under adverse dispersion conditions (stable atmosphere), the ERPG–2 distance ranges from 0.76 to 0.79 mile (1.2 to 1.3 kilometer), and the ERPG–3 distance ranges from 0.32 to 0.33 mile (0.52 to 0.53 kilometer). Under conservative daytime dispersion conditions, the ERPG–2 distance ranges from 0.62 to 0.71 miles, and the ERPG–3 distance ranges from 0.27 to 0.31 mile. The average number of people exposed under conservative daytime dispersion conditions is shown in Table G.5.5.3–1.

G.5.5.4 CHEM–04, Single Container Release of Toxic Gas from Waste Gas Cylinder Storage

General Scenario Description

TA–54–216 is located at TA–54 Area L, which provides permitted storage for hazardous waste and liquid- or volatile-organic-containing waste that is contaminated with both hazardous and radioactive components. The TA–54–216 storage canopy is used to store waste gas cylinders pending final determination of disposal options. The storage canopy is a fabric dome structure that is open on three sides (east, north, and west) to provide ventilation.

From 1983 to November 1996, TA–54–216 has received a total of 4,144 waste cylinders. Currently, approximately 200 cylinders are stored at the facility and are representative of what TA–54–216 is anticipated to have in inventory in the future. Occasionally, a large influx of gas cylinders may occur due to decontamination and decommissioning activities at LANL.

Activities at TA–54–216 are generally limited to the receipt, storage, staging, and shipment of gas cylinders. Gas cylinders are stored and moved in gas cylinder racks by forklift (gasoline or electric). At some time in the future, it will be necessary to repackage some of the gases into DOT-qualified packages so that they may be shipped off site for disposal. Facility activities generally do not involve the removal of cylinder valve covers (some do not have covers but the cylinder design protects the valve). The exception to this is when the valve covers are briefly removed for verification that the valves are secure and leak-tight prior to off-site shipment for disposal.

Based on the type of activities conducted at TA–54–216, potential accident initiators leading to an individual cylinder release include

random failure of a cylinder, failure of a cylinder due to a forklift accident, or human error during cylinder handling.

This accident was not evaluated in LANL safety analysis documentation reviewed in the preparation of the SWEIS.

Properties of Selenium Hexafluoride Gas

Selenium hexafluoride is a colorless toxic gas (TWA is 0.05 parts per million) that irritates the skin and eyes; may cause severe pulmonary irritation with coughing, choking, and shortness of breath; and also may cause pulmonary edema. It is stable at normal temperatures but has hazardous decomposition products. There is no evidence of carcinogenicity.

No Action Alternative Frequency Analysis

The frequency of a single cylinder release of any gas was calculated at TA-54-216 using the inventory of gas cylinders at the facility and associated movements. This provides a bounding estimate of risk associated with a single cylinder release and gives a broader representation of risk for site-wide activities potentially leading to a single container release of a toxic gas (postulated chlorine releases are evaluated separately).

Human error contributions (dropping a cylinder during handling with valve cover removed or improperly installed) are considered negligible for off-site shipments. This is based on verification of valve leak tightness while the cylinder is in the cylinder rack (precluding a drop accident), the low probability of the valve cover being improperly reinstalled (this would be self evident), and the hazards training and awareness of involved personnel. The combined frequency (F_{TOTAL}) of a single cylinder release may be quantified as:

$$F_{TOTAL} = F_{RANDOM} + F_{FORKLIFT}$$

where:

F_{RANDOM} = Frequency of a toxic gas release due to a random cylinder failure

$F_{FORKLIFT}$ = Frequency of a toxic gas release due to a forklift accident

Random cylinder failure can occur due to a variety of causes (including cylinder defects, weathering, corrosive attack, damage to valving). For random failure, the frequency can be estimated as follows:

$$F_{RANDOM} = 8,760 \times R_{HOURLY} \times N_{CYL}$$

where:

F_{RANDOM} = Frequency of a toxic gas release due to a random cylinder failure

8,760 = Number of hours in a year (24 hours x 365 days)

R_{HOURLY} = Random failure rate of pressurized cylinder (10^{-9} per hour; Mahn et al.1995)

N_{CYL} = Number of toxic gas cylinders at risk (200 representative inventory)

Thus, the above equation can be quantified as follows:

$$\begin{aligned} F_{RANDOM} &= 8,760 \times R_{HOURLY} \times N_{CYL} \\ &= 8,760 \text{ hr} \times (1 \times 10^{-9}/\text{hr}) \times 200 \\ &= 1.8 \times 10^{-3} \text{ per year} \end{aligned}$$

The frequency of a forklift accident leading to a release of a toxic gas from a single cylinder may be analyzed using the following equation:

$$F_{FORKLIFT} = N_{FMOVE} \times C_{PFACC} \times C_{PCFAIL}$$

where:

$F_{FORKLIFT}$ = Frequency of a toxic gas release due to a forklift accident

N_{FMOVE} = Number of forklift movements per year

C_{PFACC} = Conditional probability of a forklift accident per movement

C_{PCFAIL} = Conditional probability of toxic gas cylinder failure per forklift accident

Between 1983 and November 1996, TA-54-216 received 4,144 toxic waste cylinders. Thus, annual throughput is approximated as 300 (4,144/14) toxic gas cylinders per year. Forklift movements at TA-54-216 occur at the time of receipt and for off-site shipment. Additionally, it is assumed that at least one forklift movement is made for inventory control/staging while stored at TA-54-216. Multiple cylinders are stored in racks. It is conservatively assumed that only two cylinders are stored per rack, resulting in an estimated 450 (3 x 300/2) forklift movements per year. The conditional probability of a forklift accident is estimated as 1×10^{-5} per forklift movement (LANL 1995g). Not all forklift accidents will be of sufficient severity to result in damage to a cylinder and a release of its contents. The conditional probability depends on the nature of the accident and how the individual cylinder is mechanically impacted by drop, puncture, and crush forces. There is a potential that any forklift accident at TA-54-216 would be aggravated by the uneven grade at the facility. There is an elevation grade transition of approximately 3.3 feet (1 meter) that runs through the center length of the canopy. To account for the foregoing, and because some of the cylinders are not U.S. Department of Transportation (DOT) certified, it is conservatively assumed that the conditional probability of a single cylinder failure per forklift accident is 0.5. Forklift accidents also may also involve multiple cylinder failures, such as a forklift fuel tank fire. This component of risk is quantified in accident Scenario CHEM-05.

Thus, the above equation can be quantified as follows:

$$\begin{aligned} F_{\text{FORKLIFT}} &= N_{\text{FMOVE}} \times C_{\text{PFACC}} \times C_{\text{PCFAIL}} \\ &= 450 \text{ moves} \times (1 \times 10^{-5} \text{ per move}) \times 0.5 \\ &= 2.3 \times 10^{-3} \text{ per year} \end{aligned}$$

From the above analyses, the combined frequency of occurrence for a single cylinder release of toxic gas is estimated as:

$$\begin{aligned} F_{\text{TOTAL}} &= F_{\text{RANDOM}} + F_{\text{FORKLIFT}} \\ &= (1.8 \times 10^{-3}) + (2.3 \times 10^{-3}) \\ &= 4.1 \times 10^{-3} \text{ per year} \end{aligned}$$

Expanded Operations Alternative, Reduced Operations Alternative, and Greener Alternative Frequency Analysis

There are no differences in operations or throughput across the alternatives for this scenario. Accordingly, the No Action Alternative frequency value represents all alternatives.

Uncertainties and Sensitivities Affecting the Frequency of CHEM-04

Several uncertainties are associated with the selected accident scenario frequency and conditional probability parameters. In all cases, realistically conservative values have been used based on identified accident conditions and facility-specific conditions.

Source Term Calculations

Accident screening of the historical chemical inventory data identified selenium hexafluoride as the dominant chemical-of-concern for a single toxic gas cylinder (75 liters) release. This chemical had the greatest ERPG-2 and ERPG-3 distances for a single cylinder out of the historical inventory, which should be

broadly representative of future activities. In fact, it should be generally the case that future gas cylinders passing through TA-54-216 would be less hazardous than in the past, due to effort by LANL to reduce its inventory of hazardous chemicals.

The release is modeled as a direct release of 7.5 liters of gas per minute for 10 minutes. The release is modeled in this manner because there is insufficient information available regarding cylinder size and pressure to perform a more precise calculation. There is no variation in the MAR or postulated accident conditions from the No Action Alternative across the remaining alternatives.

Uncertainties and Sensitivities Affecting the Source Term for CHEM-04

The source term calculation is based on the single cylinder's size and chemical producing the largest ERPG-2 and ERPG-3 distances for the toxic gas cylinders processed through TA-54-216 in the historical database. Given this, unless circumstances change significantly (i.e., a much more toxic chemical is handled in significant quantity), this release should be bounding. It should be noted that it is conservative to assume that the cylinder is full; it is likely that the inventory may have been partially or largely depleted during use.

Consequences of CHEM-04 for Facility Workers and the Public

Typically four to five people actively work in the Area L yard in which TA-54-216 is located. An additional ten people may be present in the yard in support of construction activities. Depending on the nature of activity at TA-54-216, zero to three people would be expected to be present at the facility itself.

Traumatic injuries or fatalities could occur from missiles for any individuals present at the time of cylinder rupture or involved in the forklift accident. Health consequences from the toxic

nature of the released gas also may occur. Depending on exposure levels and durations, four possible adverse health outcomes may result: (1) mild, transient adverse health effects; (2) reversible, but more serious adverse health effects; (3) irreversible, adverse health effects; and (4) life-threatening health effects.

For outdoor incidents, facility workers are trained (Emergency Action Plan) to stop all activity and to leave the immediate area for any release of an unknown substance or known hazardous substance. Personnel are trained to alert others and to activate applicable alarms on the way out and to proceed upwind (based on direction of visible windsock, wind vane, or other indicators) to the nearest muster station. If not at immediate risk, the worker is trained to shutdown equipment. Emergency response planning also includes provisions for evacuation. These actions will serve to mitigate impacts to workers.

Under adverse dispersion conditions, the ERPG-2 distance is about 230 yards (210 meters). Under conservative daytime dispersion conditions, the ERPG-3 and ERPG-2 exposure distances are less than 100 yards. The average number of people exposed to greater than ERPG-3 and ERPG-2 concentrations for conservative daytime dispersion is provided in Table G.5.5.4-1.

G.5.5.5 *CHEM-05, Multiple Cylinder Release of Toxic Gas from Waste Gas Cylinder Storage at TA-54-216*

General Scenario Description

This scenario occurs at the same facility as CHEM-04; however, it differs in that the consequence results from the bounding historical inventory of chemicals present in multiple cylinders. Accident screening of the

historical chemical inventory data identified sulfur dioxide as the dominant chemical-of-concern for a multiple toxic gas cylinder release.

Properties of Sulfur Dioxide Gas

Sulfur dioxide is a colorless, nonflammable gas (or liquid under pressure). Sulfur dioxide (SO₂) is listed on EPA's Extremely Hazardous Substances List. It is a poisonous gas chiefly affecting the upper respiratory tract and the bronchi, and it is also a corrosive irritant to the eyes, skin, and mucous membranes (Lewis 1993).

CHEM-05 Release Mechanisms

Based on the type of activities conducted at TA-54-216, potential accident initiators leading to a multiple cylinder release include propagation of a random failure of a cylinder (rupture) from missiles, a forklift fire or a delivery/shipment truck fire incident, or rupture and subsequent BLEVE (boiling liquid expanding vapor explosion) of the adjacent propane tank. The resulting fireball and thermal radiation would be the primary concern associated with potential to impact multiple cylinders. Propane tank leak explosion hazards include the potential for significant overpressure and missiles.

No Action Alternative Frequency Analysis

While sulfur dioxide is the dominant chemical-of-concern for a multiple cylinder release, the frequency of a multiple cylinder release of any gas was calculated at TA-54-216 using the typical inventory of gas cylinders at the facility and associated movements. This provides a bounding estimate of risk associated with a multiple cylinder release of sulfur dioxide and gives a broader representation of risk for site-wide activities potentially leading to a multiple cylinder release of a toxic gas (postulated chlorine releases are evaluated separately).

Potential accident initiators leading to a multiple cylinder release include propagation of

a random failure of a cylinder (rupture) from missiles, a forklift fire or a delivery/shipment truck fire incident, or rupture and subsequent BLEVE/explosion of the adjacent propane tank. Thus, the combined frequency (F_{TOTAL}) of a multiple cylinder release may be quantified as:

$$F_{TOTAL} = F_{RANDOM} + F_{FLFTFIRE} + F_{TRKFIRE} + F_{PROTANK}$$

where:

F_{RANDOM} = Frequency of a toxic gas release due to a random cylinder failure

F_{FLFTFIRE} = Frequency of a toxic gas release due to a forklift fire

F_{TRKFIRE} = Frequency of a toxic gas release due to a truck fire

F_{PROTANK} = Frequency of a toxic gas release due to detonation of the propane tank

Random failure can occur due to a variety of causes (including cylinder defects, weathering, corrosive attack, damage to valving). For propagation of a random failure resulting in a multiple cylinder release, the frequency (F_{RANDOM}) can be estimated as follows:

$$F_{RANDOM} = 8,760 \times R_{HOUR} \times N_{CYL} \times C_{PROP}$$

where:

8,760 = Number of hours in a year (24 hours x 365 days)

R_{HOUR} = Random failure rate of pressurized cylinder (1 x 10⁻⁹/hr) (Mahn et al.1995)

N_{CYL} = Number of toxic gas cylinders at risk (200 representative inventory)

C_{PROP} = Conditional probability of propagating failure given one cylinder ruptures

The CMR Building SAR (LANL 1995c) indicates based on historical experience that a leak is 20 times more likely to occur than a

rupture. Leaks will not propagate unless the leaked gas is flammable or pyrophoric; sulfur dioxide is neither. Consequently, conservatively assuming that propagation occurs given a rupture, the conditional probability of propagation is 0.05 (1/20). This value is considered to be very conservative, especially considering the separation of several of the cylinder racks to accommodate forklift movements. The above equation can be quantified as follows:

$$\begin{aligned} F_{\text{RANDOM}} &= 8,760 \times R_{\text{HOUR}} \times N_{\text{CYL}} \times C_{\text{PROP}} \\ &= 8,760 \times (1 \times 10^{-9}) \times 200 \times 0.05 \\ &= 8.8 \times 10^{-5} \text{ per year} \end{aligned}$$

The frequency of a forklift fire (F_{FLFTFIRE}) leading to a release of toxic gas from multiple cylinders may be analyzed using the following equation:

$$F_{\text{FLFTFIRE}} = N_{\text{FMOVE}} \times N_{\text{HOUR}} \times F_{\text{FUEL}} \times C_{\text{PING}}$$

where:

N_{FMOVE} = Number of forklift movements per year

N_{HOUR} = Number of hours per forklift movement

F_{FUEL} = Frequency of a fuel tank rupture per hour

C_{PING} = Conditional probability of ignition given a fuel tank rupture and subsequent propagation of failure

From 1983 to November 1996, TA-54-216 received 4,144 waste cylinders. Thus, annual throughput has been approximately 300 (4,144/14) cylinders per year. Forklift movements at TA-54-216 occur at the time of receipt and for off-site shipment. Additionally, it is assumed that at least one forklift movement is made for inventory control/staging while

stored at TA-54-216. Multiple cylinders are stored in racks. It is conservatively assumed that only two cylinders are stored per rack, resulting in an estimated 450 (3 x 300/2) forklift movements per year. It is conservatively assumed that each forklift movement has a duration of 0.5 hour.

The frequency of a forklift fuel tank rupture and a resulting fire is assessed for TA-54-214 based on methods and data contained in the TA-54, Area G hazard analysis (LANL 1995g) and the evaluation of ignition probabilities given a tank rupture by the Reliability Analysis Center in Rome, New York (RAC 1991). The frequency of a fuel tank rupture was assessed as 2.3×10^{-5} per hour in the TA-54 hazard analysis (LANL 1995g). For a nondiesel fuel (propane), the conditional probability of ignition given a rupture is assigned a value of 1×10^{-2} .

Thus, the above equation can be quantified as follows:

$$\begin{aligned} F_{\text{FLFTFIRE}} &= N_{\text{FMOVE}} \times N_{\text{HOUR}} \times F_{\text{FUEL}} \times C_{\text{PING}} \\ &= 450 \times 0.5 \times (2.3 \times 10^{-5}) \times 0.01 \\ &= 5.2 \times 10^{-5} \text{ per year} \end{aligned}$$

The frequency of a truck fuel leak and fire contributor accident can be estimated using the following equation:

$$F_{\text{FIRE}} = N_{\text{SHIPMENTS}} \times C_{\text{LEAK}} \times C_{\text{PFIRE}}$$

where:

F_{FIRE} = Frequency of a fire at TA-54-216

$N_{\text{SHIPMENTS}}$ = Number of shipments to or from TA-54-216 per year

C_{LEAK} = Conditional probability of fuel leak per shipment

C_{PFIRE} = Conditional probability of a fire given a fuel leak and subsequent propagation of failure

The frequency of a fuel system leak or fuel tank leak and a resulting fire is assessed for TA-54-216 based on methods and data contained in the TA-54, Area G Hazard Analysis (LANL 1995g) and the evaluation of TRU waste transportation by H&R Technical Associates, discussed in section G.5.5.1. On a per trip basis, the likelihood of a fuel leak is 0.1/78, or 1.3×10^{-3} per trip. The conditional probability of a fire given a fuel leak is 4.7×10^{-3} per fuel leak. The number of shipments is estimated at 60 shipments per year (300 cylinder throughput per year \times 2 shipments per cylinder/10 cylinders per shipment). Thus, the above equation can be quantified as follows:

$$\begin{aligned} F_{\text{FIRE}} &= N_{\text{SHIPMENTS}} \times C_{\text{LEAK}} \times C_{\text{PFIRE}} \\ &= 60 \times (1.3 \times 10^{-3}) \times (4.7 \times 10^{-3}) \\ &= 3.7 \times 10^{-4} \text{ per year} \end{aligned}$$

For a random tank failure and subsequent BLEVE/explosion (F_{RANDOM}), the frequency can be estimated as follows:

$$F_{\text{RANDOM}} = 8,760 \times R_{\text{HOUR}} \times C_{\text{PEXP}}$$

where:

8,760 = Number of hours in a year (24 hours \times 365 days)

R_{HOUR} = Random tank failure rate per hour

C_{PEXP} = Conditional probability of a BLEVE/explosion and subsequent propagation of failure

The random failure rate of a pressurized tank, accounting for in-service inspections is 10^{-10} per hour (Mahn et al. 1995). The conditional probability of a BLEVE/explosion versus no ignition or jet flaming is conservatively estimated to be 0.25 on the basis that propane has a very narrow explosive range (lower explosive limit of 2.1 and an upper explosive limit of 9.5) (MGP 1997).

Thus, the above equation can be quantified as follows:

$$\begin{aligned} F_{\text{RANDOM}} &= 8,760 \times R_{\text{HOUR}} \times C_{\text{PEXP}} \\ &= 8,760 \times (1 \times 10^{-10}) \times 0.25 \\ &= 2.2 \times 10^{-7} \text{ per year} \end{aligned}$$

From the above analyses, the combined frequency of occurrence for a multiple cylinder release of toxic gas is estimated as:

$$F_{\text{TOTAL}} = F_{\text{RANDOM}} + F_{\text{FLFTFIRE}} + F_{\text{TRKFIRE}} + F_{\text{PROTANK}}$$

$$F_{\text{TOTAL}} = (8.8 \times 10^{-5}) + (5.2 \times 10^{-5}) + (3.7 \times 10^{-4}) + (2.2 \times 10^{-7})$$

$$F_{\text{TOTAL}} = 5.1 \times 10^{-4} \text{ per year}$$

Expanded Operations Alternative, Reduced Operations Alternative, and Greener Alternative Frequency Analysis

No differences in operations across the alternatives have been identified for this accident scenario. Accordingly, the above frequency calculations represent all alternatives.

Uncertainties and Sensitivities Affecting the Frequency of CHEM-05

Several uncertainties are associated with the selected accident scenario frequency and conditional probability parameters. In all cases, realistically conservative values have been used based on identified accident conditions and facility specifics.

Source Term Calculations

The source term for this accident scenario is based on a release of the contents of multiple toxic gas cylinders. Accident screening of the current chemical inventory data identified sulfur dioxide as the dominant chemical-of-concern for a multiple toxic gas cylinder (136 liters) release. The release is modeled as two,

150-pound cylinders releasing 30 pounds per minute for 10 minutes. The release is modeled as a continuous release because insufficient information is available concerning the cylinder size and pressure.

Uncertainties and Sensitivities Affecting the Source Term for CHEM-05

Sulfur dioxide is the dominant chemical-of-concern from a toxic standpoint. Source term uncertainties include the total number of cylinders that may be affected by a specific accident initiator, the release rate from the cylinders, and the possible influences of building wakes and buoyancy considerations for fire events.

Consequences of CHEM-05 for Facility Workers and the Public

Typically four to five operations personnel actively work in the Area L yard where TA-54-216 is located. An additional ten people may be present in the yard in support of construction activities. Depending on the nature of activity at TA-54-216, zero to three people would be expected to be present at the facility itself.

Traumatic injuries or fatalities could occur from missiles for any individuals present at the time of the postulated cylinder ruptures or involved in the forklift/truck fire incidents. Health consequences from the toxic nature of the released gas also may occur. Depending on the exposure levels and durations, four possible adverse health outcomes may result: (1) mild, transient adverse health effects; (2) reversible but more serious adverse health effects; (3) irreversible, adverse health effects; and (4) life-threatening health effects.

For outdoor incidents, facility workers are trained (Emergency Action Plan) to stop all activity and to leave the immediate area for any release of an unknown substance or known hazardous substance. Personnel are trained to

alert others and to actuate applicable alarms on the way out and to proceed upwind (based on direction of visible windsock, wind vane, or other indicators) to the nearest muster station. If not at immediate risk, the worker is trained to shutdown equipment. Emergency response planning also includes provisions for evacuation. These actions will serve to mitigate impacts to the workers.

Under adverse dispersion conditions (stable atmosphere), the ERPG-2 distance is 1.7 miles (2.7 kilometers), while the ERPG-3 distance is 0.75 mile (1.2 kilometer). Under conservative daytime dispersion conditions, the ERPG-2 distance ranges from 0.62 to 0.81 mile (1.0 to 1.3 kilometers), while the ERPG-3 distance ranges from 0.28 to 0.34 mile (0.45 to 0.55 kilometer). The average affected population at higher than ERPG-2 and ERPG-3 concentrations under conservative daytime dispersion conditions is shown in Table G.5.5.5-1. There are only two directions (west and northwest) where the off-site population can be exposed, due to the remoteness of the site.

G.5.5.6 CHEM-06, Chlorine Gas Release from Outside the Plutonium Facility

General Scenario Description

TA-55-4 is the LANL Plutonium Facility. At TA-55-4, gaseous chlorine is used for various processes. The chlorine is supplied by piping from a 150-pound cylinder that is kept in a storage room for corrosive and toxic gases, outside TA-55-4. When the chlorine is not in use, the piping is shut off at the chlorine tank valve, and the line is purged and then pressurized with argon to prevent leaks during off-duty hours (LANL 1996k).

In this scenario, a chlorine release occurs due to a failure of piping associated with a chlorine gas cylinder. The piping failure is assumed to occur

outside TA-55-4, leading to a release directly to the atmosphere (LANL 1996k). Chlorine is a heavy gas, which will affect the downwind dispersion of the gas following release. The properties of chlorine gas and heavy gases are discussed in section G.5.5.1.

Accident Scenario CHEM-06 was analyzed in detail in the TA-55-4 SAR. The SAR analysis considered significant inventories of hazardous chemicals with potential for release affecting workers and the off-site population. The hazard analysis that underlies the SAR identified a spill of nitric acid, a spill of hydrochloric acid, a release of gaseous fluorine or hydrogen fluoride, and a release of gaseous chlorine as possible scenarios (LANL 1996k).

The SAR evaluated the tests through which DOT-approved storage cylinders are placed, and concluded that catastrophic failures of gas bottles are not expected. Rather, the SAR found that chronic releases from improper or failed connectors at piping manifolds are the most likely cause of a release. Using a Gaussian dispersion model, the SAR analyzed the consequences of the bounding toxic gas releases at a 2,952-foot (900-meter) distance where public exposure is possible. Chlorine was found to produce the bounding consequence (LANL 1996k).

The SAR analysis assumed a release of 150 pounds of chlorine gas over a 15-minute period at a release height of 16 feet (5 meters). The downwind concentration of chlorine was calculated using the CHEM-MIDAS heavy gas dispersion model, and evaluated for adverse dispersion conditions (in this case, stability Class F and 1.9 meters per second wind speed). The code calculated a concentration at the Royal Crest Trailer Court of 8 parts per million (LANL 1996k). The ERPG-3 concentration for chlorine is 20 parts per million, while the ERPG-2 level is 3 parts per million.

CHEM-06 Release Mechanisms

The TA-55 SAR assumed the chlorine release was due to a break in the line outside TA-55-4.

No Action Alternative Frequency Analysis

During the facility walkdown, it was learned that the TA-55 SAR frequency bin assignment of 10^{-2} to 10^{-1} per year for this scenario was based on one event in 16 years (1978 to 1996) in which a cylinder of chlorine was partially released as a result of mechanical damage to the gas line. Because this was a partial failure, the calculation of frequency based on one event in 16 years (6.3×10^{-2} per year) is conservative.

Expanded Operations Alternative, Reduced Operations Alternative, and Greener Alternative Frequency Analysis

There are no differences in operations across the alternatives affecting the chlorine system. The frequency estimated above for the No Action Alternative is considered to be applicable to the remaining alternatives.

Uncertainties and Sensitivities Affecting the Frequency of CHEM-06

The TA-55 hazard analysis places the rupture of the gas manifold due to impact by heavy equipment in the frequency bin from 10^{-4} to 10^{-2} per year (LANL 1996l). The hazard analysis also identifies a gas leak in Room 116 in the same frequency bin, citing Unusual Occurrence Report 89832 (LANL 1996l). Figure 2A-3 of the TA-55 SAR identifies Room 116 of TA-55-4 as a corridor between the 100 Area and 200 Area rooms on the first floor of the building. This release would affect TA-55-4 workers in the first instance, but would ultimately be released to the environment.

Other failure modes for chlorine release are possible, such as random cylinder or manifold failure, or human error during cylinder

changeout (see section G.5.5.1). Given the much lower level of activity at TA-55-4 for chlorine cylinder changeout, the experience-based frequency cited above is selected.

Source Term Calculations

The release is assumed to be a ground level release of a full, 150-pound cylinder. There are no differences in source term across the SWEIS alternatives. The release is modeled as a 15-pound per minute release into the building for 10 minutes, in accordance with the description of the release in the TA-55 SAR.

The EPA RMP off-site consequence analysis guidance issued in 1996 indicates that when a toxic gas is released inside a building that has direct contact with the outside environment (such as a shed), the release rate is ameliorated somewhat due to mixing within the shed. The guidance suggests multiplying the release rate by 0.55 (EPA 1996). In order to obtain the release duration, it is then necessary to divide the total quantity released by the effective release rate. When this method is applied to the TA-55 chlorine gas leak, the release duration is increased to 18.2 minutes and the outdoor concentrations proportionately reduced.

Uncertainties and Sensitivities Affecting the Source Term for CHEM-06

The release rate from the cylinder itself is modeled as a continuous rate; whereas, releases from cylinders vary with time. The 10-minute period is regarded as conservative. The factor of 0.55 accounting for the retention time prior to release to the outdoors is uncertain for this storage shed.

Consequences of CHEM-06 for Facility Workers and the Public

Facility worker and public consequences are addressed separately. Because the air intakes for TA-55-4 are on the west end of the building at a point centered 18 feet (5.5 meters) above the ground, and the chlorine release point is on the north side of the building (LANL 1996k), it is unlikely that chlorine released into the air would be drawn into the building by the ventilation system. Moreover, there is a 30-inch (76-centimeter) diameter butterfly valve in the intake ductwork that can be closed manually to act as a shut-off valve (LANL 1996k). TA-55 personnel located outdoors at the time of the accident could be exposed to high concentrations of chlorine. However, these personnel would be in a position to evacuate from the affected area very quickly (being outdoors), which should reduce the potential for health effects.

Under adverse dispersion conditions (stable atmosphere), the ERPG-2 distance ranges from 0.58 to 0.66 mile (0.93 to 1.1 kilometer), while the ERPG-3 distance is 0.2 mile (0.32 kilometer). Under conservative daytime dispersion conditions, the ERPG-2 distance is about 0.27 mile (0.43 kilometer), while the ERPG-3 distance is about 0.10 mile (0.16 kilometer). The average number of members of the public exposed above ERPG-2 and ERPG-3 concentrations under conservative daytime dispersion conditions is shown in Table G.5.5.6-1.

TABLE G.5.5.6-1.—Summary Results for Scenario CHEM-06

ALTERNATIVE	ACCIDENT FREQUENCY	SOURCE TERM AND CONSEQUENCES
No Action	6.3×10^{-2}	150 pounds of chlorine released in 18.2 minutes; average number of people exposed above ERPG-2 and ERPG-3 concentrations is 102 and 7, under conservative daytime dispersion conditions.
Expanded Operations	6.3×10^{-2}	Same as No Action Alternative.
Reduced Operations	6.3×10^{-2}	Same as No Action Alternative.
Greener	6.3×10^{-2}	Same as No Action Alternative.

G.5.6 Radiological Accidents

G.5.6.1 *RAD-01, TRU Waste Container Storage Area Fire at NDA/NDE Facility (TA-54-38)*

General Scenario Description

The Nondestructive Assay/Nondestructive Examination (NDA/NDE) Facility conducts verification assay and radiographic examination of unopened waste containers to confirm compliance with waste acceptance criteria (WAC). An outdoor container storage area (40 feet by 40 feet [12 meters by 12 meters]) is designated to stage waste processed through the facility. The outdoor Container Storage Area has a RCRA Part B permitted capacity of 7,920 gallons of mixed waste, which is equivalent to 144, 55-gallon drums. However, the capacity of the Container Storage Area is administratively controlled to 23 DOT Type A drums (of the type used for TRU waste). Scenario RAD-01 involves an airborne release of radioactive material due to a fire that develops at the outdoor Container Storage Area.

Properties of TRU Waste. Transuranic waste contains at least 100 nanocuries per gram of transuranium isotopes (primarily plutonium and americium). It is present in a wide variety of forms at LANL, some of which are combustible (e.g., paper, plastic, etc.) and some of which are not combustible (e.g., concrete).

RAD-01 Release Mechanisms. Potential accident initiators include: (1) truck fires, (2) forklift fires, (3) external fires (wild fires), (4) lightning strikes, and (5) aircraft accidents. Aircraft crash was evaluated in section G.4 and is not considered further here. Lightning may strike the Container Storage Area or pose an indirect hazard by initiating a wildfire. The Container Storage Area does not have lightning protection; however, a lightning strike would, at

most, pose a localized hazard due to ignition of combustible waste. It would have a very limited opportunity to propagate with waste contained in metal drums and the low combustible loading of the storage array. Wild fires, initiated by lightning strikes or otherwise, do not pose a significant hazard considering the developed nature of the area (e.g., pavement) and the time available to take mitigative actions. A forklift fire would be credible but would be significantly bounded by the MAR for a truck fire accident.

Two truck fire scenarios could occur. The first is an accident involving a truck that causes a fuel leak and subsequent fire involving the Container Storage Area. This is judged not to be credible considering the low truck speeds involved in the confined yard area and the limited vehicle traffic, with the exception of forklift activity. The second involves a truck parked near the Container Storage Area that could experience a fuel system leak or fuel tank leak due to causes unrelated to a vehicle accident. Once a fuel leak occurs, ignition of the spilled fuel would lead to a fire that, if it is close enough to the Container Storage Area and if it is not suppressed, would envelop multiple waste containers. This scenario is retained for analysis. The TA-54-38 safety assessment did not evaluate the potential for a Container Storage Area fire (LANL 1996j).

No Action Alternative Frequency Analysis

The frequency of a truck fuel leak and subsequent fire accident can be estimated using the following equation:

$$F_{\text{FIRE}} = N_{\text{SHIPMENTS}} \times C_{\text{LEAK}} \times C_{\text{PFIRE}}$$

where:

F_{FIRE} = Frequency of truck fuel leak and fire

$N_{\text{SHIPMENTS}}$ = Number of shipments to or from the outdoor Container Storage Area at TA-54-38 per year

C_{LEAK} = Conditional probability of fuel leak per shipment

C_{PFIRE} = Conditional probability of a fire given a fuel leak

The frequency of a fuel system leak or fuel tank leak and a resulting fire is assessed for the outdoor Container Storage Area based on methods and data contained in the TA-54, Area G Hazard Analysis (LANL 1995g) and the evaluation of TRU waste transportation by H&R Technical Associates (Rhyne 1994). As described in section G.5.5, on a per trip basis, the likelihood of a fuel leak is 0.1/78, or 1.3×10^{-3} per trip. Similarly, as described in section G.5.5, the conditional probability of a fire given a fuel leak is 4.7×10^{-3} per fuel leak.

Facility truck movements may be associated with the loading dock, the truck bay (primarily in support of Waste Isolation Pilot Plant [WIPP] shipments), and the outdoor Container Storage Area. LANL intra-site shipments of TRU waste average approximately 16 drums per shipment, with a maximum of 40 drums. Because the Container Storage Area capacity is administratively controlled to a limit of 23 drums, it will be assumed that all shipments are 23-drum shipments. It is assumed that shipments associated with the outdoor Container Storage Area would primarily be conducted to receive waste from TA-54 Area G for staging just prior to shipment to WIPP and are insensitive to the facility throughput for assay verification. Each WIPP shipment consists of three Transuranic Packaging Transporter (TRUPACT)-IIs, each with a cargo capacity of 14 drums, for a total of 42 drums per WIPP shipment. Under the proposed action for WIPP, a total of 5,009 shipments to WIPP are projected over 35 years (DOE 1996d). This gives an average WIPP shipment rate of 143 per year. Thus, it is estimated that there are 261 ($143 \times 42/23$) shipments per year from TA-54 Area G to the outdoor Container Storage Area.

Thus, the above equation can be quantified as follows:

$$F_{FIRE} = N_{SHIPMENTS} \times C_{LEAK} \times C_{PFIRE}$$

$$F_{FIRE} = 261 \times (1.3 \times 10^{-3}) \times (4.7 \times 10^{-3})$$

$$F_{FIRE} = 1.6 \times 10^{-3} \text{ per year}$$

Expanded Operations, Reduced Operations, and Greener Alternatives Frequency Analysis

Because the above frequency analysis is based on an average WIPP shipment schedule that is unaffected by the SWEIS alternatives, the frequency calculated above is considered to be applicable to all alternatives.

Uncertainties and Sensitivities Affecting the Frequency of RAD-01

Uncertainties in the frequency point estimates include the frequency of a fuel leak per shipment, the conditional probability of a fuel fire given a fuel leak, and the number of shipments per year.

Source Term Calculations

The MAR for the postulated accident is limited by the fraction of waste inventory immediately involved in the truck fuel pool fire. The MAR is estimated based on a 100-gallon (379-liter) fuel spill, yielding a burn area of 500 square feet (46 square meters). This is based on a burn area relationship of 250 square feet (23 square meters) for 50 gallons of fuel (RFETS 1994). Even allowing for aisle spacing as required by the *Resource Conservation and Recovery Act* (RCRA), the entire Container Storage Area inventory of 23 drums could be consumed in a fire of 500 square feet (46 square meters).

Potential waste forms present include solidified liquids (aggregate); surface contaminated, packaged combustible solids; and surface contaminated, noncombustible solids. The bounding ARF and RF products for these three

waste forms in a thermal stress environment (fire) are 6×10^{-5} , 5×10^{-4} , and 6×10^{-5} , respectively (DOE 1994a). (Recall, ARF = airborne release fraction [the fraction of the material suspended in the air as an aerosol and thus available for transport due to the physical stresses from a specific accident or due to operation of HVAC systems], and RF = respirable fraction [the fraction of the aerosols that can be transported through the air and inhaled into the human respiratory system, commonly assumed to include particles of 10 microns aerodynamic equivalent diameter or less].)

Consequently, it can be concluded that releases will be dominated by combustible waste and the analysis will be limited to this waste form. It is conservatively assumed that 35 percent of the radiological inventory is present in combustible waste forms (combustible waste comprises approximately 10.3 percent of TRU waste by volume) (LANL 1996o, estimated from Table 4-1); however, the higher value is meant to account for the presence of decontamination trash, HEPA filters, and the relatively high surface contamination area to volume ratio for combustible materials. Separate calculations are performed for combustible and noncombustible forms. Thus, for the MAR (23 drums), the damage ratio is set equal to 0.35 for combustible material and at 0.65 for noncombustible forms. The Container Storage Area is located outdoors; consequently, the LPF is 1.0.

Currently, the average TRU radioactive material content per waste container is 8.9 plutonium-239 equivalent curies (PE-Ci) (LANL 1995f). Less than 1 percent of all TRU waste containers in the existing Area G inventory exceed 75 PE-Ci in radioactive material content (LANL 1995c). The predominant TRU waste generated at LANL is weapons-grade plutonium. The LANL fissile gram equivalent limit for this material type is 25 PE-Ci per drum (LANL 1995c). Revision 5 of the WIPP WAC limits the maximum

plutonium-239 equivalent activity for untreated contact-handled TRU waste to be received by the facility to 80 PE-Ci per drum (if not overpacked). Considering that the postulated accident scenario involves multiple drums (23); that the drums represent a small fraction of the total TRU waste inventory managed at LANL, and their radioactive content could be skewed to the high end (depending on the waste generator source); and the above TRU limits; it is conservatively assumed that one drum contains the WIPP WAC limit for untreated waste of 80 PE-Ci (if not overpacked) and the other 22 drums involved in the fire have an average TRU content of 25 PE-Ci.

With the above information, the initial source term equation can be quantified as follows:

$$\begin{aligned} \text{Initial Combustible Source Term} &= \text{MAR} \times \text{DR} \\ &\quad \times \text{ARF} \times \text{RF} \times \text{LPF} \\ &= [(22 \times 25 \text{ PE-Ci}) + (80 \text{ PE-Ci})] \times 0.35 \times (5 \times \\ &\quad 10^{-4}) \times 1 \times 1 \\ &= 0.11 \text{ PE-Ci} \end{aligned}$$

$$\begin{aligned} \text{Initial Noncombustible Source Term} &= \text{MAR} \times \\ &\quad \text{DR} \times \text{ARF} \times \text{RF} \times \text{LPF} \\ &= [(22 \times 25 \text{ PE-Ci}) + (80 \text{ PE-Ci})] \times 0.65 \times (6 \times \\ &\quad 10^{-5}) \times 1 \times 1 \\ &= 0.02 \text{ PE-Ci} \end{aligned}$$

$$\begin{aligned} \text{Total Initial Source Term} &= \text{Initial Combustible} \\ &\quad + \text{Initial Noncombustible} \\ &= 0.11 \text{ PE-Ci} + 0.02 \text{ PE-Ci} \\ &= 0.13 \text{ PE-Ci} \end{aligned}$$

The MAR equals the initial MAR, minus the initial source term. The DR and LPF are set to 1. The ARF and RF are assigned values of 4×10^{-5} and 1.0, respectively, based on bounding resuspension factors for surface contaminated combustible solids exposed to ambient

conditions (DOE 1994a). Thus, the suspension source term can be quantified as:

$$\begin{aligned} \text{Suspension Source Term} &= \text{MAR} \times \text{DR} \times \text{ARR} \\ &\quad \times 24 \text{ hrs} \times \text{RF} \times \text{LPF} \\ &= (630 - 0.13 \text{ PE-Ci}) \times 1 \times (4 \times 10^{-5}) \times 24 \text{ hrs} \times \\ &\quad 1 \times 1 \\ &= 0.60 \text{ PE-Ci} \end{aligned}$$

The suspension source term is conservative, considering that fire protection actions (e.g., foam, water spray) and contamination control measures would likely limit airborne releases significantly. This would reduce the suspension period from the 24 hours assumed above to a much smaller number, which could in principle be zero. The 24-hour calculation is retained as a conservative measure for impact estimation. There are no variations in source terms across the alternatives.

Uncertainties and Sensitivities Affecting the Source Term for RAD-01

A significant uncertainty for this postulated accident is quantification of the MAR in terms of the number of drums involved in the fire and their associated radioactive material content. Accepted methodologies and reasonably conservative radiological estimates have been made to provide an upper estimate of the source term.

It could be postulated that the truck fire would lead to an explosion of the truck's fuel. This accident would have a lower frequency, perhaps being incredible, but would not involve more than the 23 drums. The explosion could disperse the drums, perhaps beyond the range of the fire, but the release and airborne fraction would likely not increase. Section 5.1 of DOE Handbook 3010 (DOE 1994d) gives a median ARF of 8×10^{-5} and a bounding ARF of 5×10^{-4} for thermal stress on packaged combustible solids. The ARF used in this analysis was also 5×10^{-4} .

Consequences of RAD-01 for Facility Workers and the Public

Consequences for facility workers and the public are considered separately. On a day shift, a total of 12 facility workers (including truck bay activities) would typically be involved with facility operations and would be at risk for exposure to airborne radioactive material.

No acute fatalities are predicted to result from the postulated accident. The mean collective population dose is projected to total 72 person-rem (TEDE), resulting in 0.036 excess LCFs. Mean projected doses for MEIs (and their associated locations) and ground contamination levels are presented in Tables G.5.6.1-2 and G.5.6.1-3, respectively. Table G.5.6.1-1 summarizes the modeling results for RAD-01.

G.5.6.2 RAD-02, Natural Gas Pipeline Failure, Ingestion, and Explosion/Fire at CMR

General Scenario Description

This accident scenario involves the rupture of a 3-inch (8-centimeter) natural gas pipeline near the CMR Building (TA-3-29), no immediate ignition of the gas, transport of the gas to the CMR intake structure, and subsequent explosion and fire in Wing 7 of the CMR Building. Rupture of the natural gas pipeline is assumed to be due to construction work in the vicinity of the pipeline (the pipeline also could fail randomly, but this is a lower frequency failure mode).

Although the CMR Building itself is not served by natural gas, a buried natural gas pipeline runs along its eastern boundary. At this location, the pipeline is a 3-inch (8-centimeter) diameter, 100 psia natural gas pipeline. The specific scenario identified in the CMR SAR involves a failure of the section immediately in front of the CMR Building, which is located about

TABLE G.5.6.1-1.—Summary Results for Scenario RAD-01

ALTERNATIVE	ACCIDENT FREQUENCY	SOURCE TERM AND CONSEQUENCES
No Action	1.6×10^{-3} per year	Initial source term: 0.13 PE-Ci, elevated thermal release; suspension source term: 0.60 PE-Ci, ground-level release; mean population dose of 72 person-rem excess LCF of 0.036.
Expanded Operations	1.6×10^{-3} per year	Same as No Action Alternative.
Reduced Operations	1.6×10^{-3} per year	Same as No Action Alternative.
Greener	1.6×10^{-3} per year	Same as No Action Alternative.

TABLE G.5.6.1-2.—Predicted Mean Doses to MEIs for Scenario RAD-01

MAXIMUM EXPOSED INDIVIDUAL (MEI) DOSE (REM, TEDE)	
MEI LOCATION	DOSE
Closest public access (SA): Pajarito Road (100 m)	4.6×10^1
Special population distance: San Ildefonso Pueblo boundary (400 m)	3.5×10^0
Special population distance: Mortandad Cave (2,400 m)	1.4×10^{-1}
Closest residence: Royal Crest Trailer Park (4,300 m)	5.1×10^{-2}
Special population distance: San Ildefonso Pueblo (11,600 m)	1.3×10^{-2}

TABLE G.5.6.1-3.—Predicted Mean Ground Contamination Levels for Scenario RAD-01

RADIAL DISTANCE	PLUTONIUM-239 GROUND CONCENTRATION (BQ/m ²)
0.0 to 1.0 km	1.1×10^4
1.0 to 2.0 km	1.2×10^3
2.0 to 3.0 km	4.7×10^2
3.0 to 4.0 km	2.6×10^2
4.0 to 8.0 km	1.3×10^2
8.0 to 12.0 km	7.6×10^1
12.0 to 20.0 km	3.5×10^1
20.0 to 30.0 km	1.7×10^1
30.0 to 40.0 km	8.4×10^0
40.0 to 60.0 km	4.2×10^0
60.0 to 80.0 km	2.4×10^0

BQ/m² = Becquerel per square meter

120 meters from the CMR ventilation intakes located near the spinal corridor of the facility.

This accident scenario is analyzed in the CMR SAR (LANL 1995c). The SAR states that construction potentially leading to this event occurs about every 3 years, and that the conditional probability of damaging the line with construction equipment is 1×10^{-3} per construction event (LANL 1995c). This results in an initiating event frequency of 3.3×10^{-4} per year.

The SAR includes an event tree for evaluating the frequency of the accident scenario. The event tree accounts for the conditional probability of no external explosion, whether the gas drifts toward or away from the CMR Building, whether the concentration at the intake is above the lower explosive limit (LEL) for natural gas, whether an explosion occurs at the intake, and whether an explosion and/or a fire occur interior to the CMR Building (LANL 1995c). The event tree identifies five separate outcomes leading to an accident:

- External explosion, 1.7×10^{-4} per year
- Internal explosion without a fire, 1.6×10^{-7} per year
- Explosion at the CMR HVAC intake structure, 1.6×10^{-6} per year
- Explosion and fire at the CMR HVAC intake structure, 1.8×10^{-7} per year
- Internal explosion with a fire, 1.5×10^{-6} per year

Because the internal explosion with a fire is the most likely event having radiological consequences, this is the outcome that is modeled in the SAR and in the SWEIS. The SAR states that an internal explosion is likely to involve only one half of the laboratories in a wing because ventilation in each half of each wing is supplied by a separate supply fan. However, the remainder of the wing could be damaged by fires ignited by the explosion. The explosion also may damage the fire suppression

sprinkler system, so no credit is given for containing any fires subsequent to an explosion in a wing. Finally, if the explosion involves a significant portion of a wing, damage to the building structure may occur (such as blowing out the glass block windows and doors), creating an open leak path to the environment (LANL 1995c).

The most vulnerable sections of the CMR Building for this accident are Wings 2, 3, and 7 (and the Administrative Wing) because these wings are located on the east side of the CMR Building nearest the natural gas pipeline. The source term analysis is based on Wing 7 because that wing has the highest administrative limit on dispersible MAR of these three wings (LANL 1995c).

Wing 7 has an administrative limit of 6 kilograms of plutonium-239 equivalent in dispersible form.¹ Of this amount, one kilogram was assumed to be located outside of gloveboxes or sealed metal containers and unprotected from direct blast effects. The release is assumed to be a ground level release (LANL 1995c).

RAD-02 Release Mechanisms

This accident involves consideration of explosion and fire effects on the MAR in the CMR Building. There is a wide variety of radioactive material stored and used in the CMR Building. In the SAR and safety limits documentation, the MAR at the CMR Building is converted to equivalent grams of pure plutonium-239. Although this is an abstraction of what is actually present in the facility, it captures the radiological effects of the diverse MAR. Plutonium-239 in both powder and solution form is considered in this accident.

1. The CMR SAR expresses most radiological releases as equivalent releases of pure plutonium-239. The CMR Building has a variety of different types of MAR, including various plutonium mixtures. Wing limits are expressed in terms of plutonium-249 equivalents, and the SAR accident analysis is largely in the same units.

No Action Alternative Frequency Analysis

The annual frequency for this scenario is quantified as follows:

$$F = F_{\text{PIPE}} \times P_{\text{EXTEXP}} \times P_{\text{DRIFT}} \times P_{\text{LEL}} \times P_{\text{INTAKE}} \times P_{\text{INTEXP}} \times P_{\text{INTFIRE}}$$

where:

F = Annual frequency of the scenario

F_{PIPE} = Annual frequency of pipe rupture due to construction

P_{EXTEXP} = Conditional probability of no external explosion at pipe rupture

P_{DRIFT} = Conditional probability of natural gas drifting to HVAC intake

P_{LEL} = Conditional probability of concentration above the LEL at HVAC intake

P_{INTAKE} = Conditional probability of natural gas not exploding at HVAC intake

P_{INTEXP} = Conditional probability of internal explosion of natural gas

P_{INTFIRE} = Conditional probability of internal fire subsequent to explosion

The above equation is evaluated in accordance with the analysis in the SAR. As noted, the frequency of pipe rupture due to construction is 3.3×10^{-4} per year. (This value is consistent with generic industry data, which indicate a pipeline rupture rate of 1.25 per 1,000 miles of pipeline per year [AICE 1994]. Applied to the CMR Building, and taking into account 660 feet [201 meters] of piping in front of CMR [this is the overall width of CMR], this data yields a value of 1.6×10^{-4} per year.) The conditional probability of no external explosion was set at 0.5 (i.e., as likely as not). The conditional probability that the gas drifts toward the CMR Building is based on historical meteorological data for LANL, and is set at 0.285 (a

conservative value). The conditional probability that the gas concentration is above the LEL at the intake is evaluated at 0.0769 (based on a calculation from a Gaussian plume dispersion model). The conditional probability of no explosion at the intake is set at 0.5 (i.e., as likely as not). The conditional probability of an internal explosion and the conditional probability of a fire given an explosion, are both set at 0.9 (i.e., very likely).

The frequency equation above is evaluated as follows:

$$\begin{aligned} F &= F_{\text{PIPE}} \times P_{\text{EXTEXP}} \times P_{\text{DRIFT}} \times P_{\text{LEL}} \times P_{\text{INTAKE}} \times P_{\text{INTEXP}} \times P_{\text{INTFIRE}} \\ &= (3.3 \times 10^{-4}) \times 0.5 \times 0.285 \times 0.0769 \times 0.5 \times 0.9 \times 0.9 \\ &= 1.5 \times 10^{-6} \end{aligned}$$

Expanded Operations, Reduced Operations, and Greener Alternatives Frequency Analysis

There is no difference in construction frequency across the alternatives. No other factor potentially affecting the conditional probability of any of the other terms of the No Action Alternative frequency equation has been identified. Accordingly, the frequency of 1.5×10^{-6} per year is applicable to the Expanded Operations, Reduced Operations, and Greener Alternatives.

Uncertainties and Sensitivities Affecting the Frequency of RAD-02

The SAR accident scenario progression incorporates several inherent uncertainties that are resolved with the assignment of conservative or representative conditional probabilities using engineering/expert opinion, historical meteorological data, and supporting calculations. The terms of the frequency equation that seem to be the most subject to

uncertainty are the two conditional probabilities of explosion: P_{EXTEXP} and P_{INTAKE} .

The conditional probability of no external explosion at the time of the pipeline rupture (P_{EXTEXP}) is probably conservative because the rupture occurs as a result of mechanical damage to the pipeline, which damage (or the engine on the equipment performing the excavation) would be likely to result in ignition of the escaping gas. To illustrate, if this term has a value of 0.1 instead of 0.5, the frequency of the accident would drop to 3×10^{-7} per year.

Embedded in the analysis details of this scenario are a number of other assumptions that, if relaxed from their current conservative values, could render the scenario less likely or result in conditions under which the scenario could not progress due to insufficient gas reaching the wing to support an explosion and fire. Among these assumptions are: (1) it is assumed that the supply system can maintain a 100-psia pressure through the 3-inch pipe for the required period of time, even though the system is depressurizing through the break; (2) it is assumed that the flow rate from the broken pipe is equal to the critical flow at the initial system pressure (no credit is taken for pipe segments depressurizing as a result of the break); and (3) the fire suppression sprinkler system within the CMR Building fails 100 percent of the time given an explosion and fire (this is a conservative assumption) (LANL 1995c).

More significantly, however, DOE authorized funding for installation of a flow restriction orifice in the natural gas pipeline, which is the source of the above-described accident. This orifice will limit gas flow in the event of a pipeline break to a value that will preclude the accident from taking place. Thus, upon completion of orifice installation this accident will no longer be credible. The installation was scheduled for Fall 1997 at the time the calculations were made for this accident appendix.

Other Potential Gas Pipeline Accidents at LANL

As a result of the identification of this pipeline failure accident in the CMR SAR, consideration was given to other possible natural gas pipeline accidents at LANL. Four examples have been identified. The TA-18 SAR identified a natural gas explosion for the Hillside Vault (TA-18-26). During the walkdown of this facility, this contributor was screened on the basis of physical implausibility (e.g., the natural gas pipeline is shielded from the Hillside Vault, and there is no active ventilation system nor natural flow process that would result in ingestion of the gas into the Hillside Vault). Similarly, natural gas pipelines are located near TA-55-4. In this case, the construction of TA-55-4 is much more robust than the CMR Building (TA-55-4 has 14-inch-thick reinforced concrete walls), and the ventilation system would remain intact in the event of an explosion (the HVAC system filters are located remotely from the possible site of any explosion inside TA-55-4). In the case of both TSTA and WETF, the natural gas lines are too far from the facilities to present a credible threat. Accordingly, the CMR scenario is considered to be the bounding accident of this type.

Source Term Calculations

The initial source term equation is evaluated four times for four separate source term contributors identified in discussions with CMR facility representatives, and is based on the draft 1996 SAR update for the CMR facility. The four sources of release are MAR in containers and enclosures affected by the explosion, MAR in solution outside an enclosure affected by the explosion, MAR in powder form affected by the fire, and MAR in solution affected by the fire. The initial source term equation is evaluated as follows for these sources:

$$ST_{\text{POWEXP}} = \text{MAR} \times \text{DR} \times \text{ARF} \times \text{RF} \times \text{LPF}$$

$$ST_{\text{POWEXP}} = 2,500 \times 1 \times 0.005 \times 0.3 \times 1 = 3.8 \text{ grams}$$

$$ST_{\text{SOLEXP}} = \text{MAR} \times \text{DR} \times \text{ARF} \times \text{RF} \times \text{LPF}$$

$$ST_{\text{SOLEXP}} = 500 \times 1 \times 1 \times 1 \times 1 = 500 \text{ grams}$$

$$ST_{\text{POWFIRE}} = \text{MAR} \times \text{DR} \times \text{ARF} \times \text{RF} \times \text{LPF}$$

$$ST_{\text{POWFIRE}} = 2,487 \times 1 \times 0.006 \times 0.01 \times 1 = 0.1 \text{ grams}$$

$$ST_{\text{SOLFIRE}} = \text{MAR} \times \text{DR} \times \text{ARF} \times \text{RF} \times \text{LPF}$$

$$ST_{\text{SOLFIRE}} = 3,000 \times 1 \times 0.002 \times 1 \times 1 = 6.0 \text{ grams}$$

$$\begin{aligned} \text{Total Initial Source Term} &= ST_{\text{POWEXP}} + ST_{\text{SOLEXP}} + ST_{\text{POWFIRE}} + ST_{\text{SOLFIRE}} \\ &= 3.8 + 500 + 0.1 + 6.0 = 510 \text{ grams} \end{aligned}$$

where:

ST = Source Term

ST_{POWEXP} = Source term from powder in containers affected by the explosion

ST_{SOLEXP} = Source term for solution affected by the explosion

ST_{POWFIRE} = Source term for powder affected by the fire

ST_{SOLFIRE} = Source term for the solution affected by the fire

The CMR SAR did not account for source term contribution from suspension subsequent to the explosion and fire. The suspension source term calculation would come from three sources (the fourth possible source, the solution affected by the explosion, has no suspension source term contribution because it was 100 percent released in the initial source term): (1) MAR in containers and enclosures affected by the explosion, (2) MAR in powder form affected by

the fire, and (3) MAR in solution affected by the fire. The suspension source term equation is evaluated three times for these sources:

$$RST_{\text{POWEXP}} = \text{MAR} \times \text{DR} \times \text{ARR} \times 24 \text{ hrs} \times \text{RF} \times \text{LPF}$$

$$RST_{\text{POWEXP}} = 2,496 \times 1 \times (4 \times 10^{-6}/\text{hr}) \times 24 \text{ hrs} \times 1 \times 1$$

$$RST_{\text{POWEXP}} = 0.24 \text{ grams}$$

$$RST_{\text{POWFIRE}} = \text{MAR} \times \text{DR} \times \text{ARR} \times 24 \text{ hrs} \times \text{RF} \times \text{LPF}$$

$$RST_{\text{POWFIRE}} = 2,487 \times 1 \times (4 \times 10^{-6}/\text{hr}) \times 24 \text{ hrs} \times 1 \times 1$$

$$RST_{\text{POWFIRE}} = 0.24 \text{ grams}$$

$$RST_{\text{SOLFIRE}} = \text{MAR} \times \text{DR} \times \text{ARR} \times 24 \text{ hrs} \times \text{RF} \times \text{LPF}$$

$$RST_{\text{SOLFIRE}} = 2,994 \times 1 \times (4 \times 10^{-8}/\text{hr}) \times 24 \text{ hrs} \times 1 \times 1$$

$$RST_{\text{SOLFIRE}} = 0.003 \text{ grams}$$

The total suspension source term is the sum of the above contributors, or 0.48 grams.

Suspension source term parameters were selected as follows: (1) based on a homogeneous bed of powder buried under structural debris exposed to ambient conditions or under static conditions within a structure (DOE 1994d); (2) based on the same considerations as (1); and (3) based on a solution indoors, on heterogeneous surfaces, covered with debris or under static conditions (DOE 1994d).

No variations are identified in the progression of the accident or the MAR; thus, the calculated source terms above are considered to represent the accident for all alternatives.

Uncertainties and Sensitivities Affecting the Source Term for RAD-02

The source term for this postulated accident scenario is dominated by the very conservative SAR assumption of an ARF of 1.0 for the solution affected by the explosion. The explosive yield of the explosion inside the wing is not identified in the CMR SAR. DOE Handbook 3010-94 recommends that for detonations in or immediately contiguous to a pool of liquid, a bounding release is assessed to be the mass of inert material equal to the calculated TNT equivalent (DOE 1994d). However, it is not evident that the explosion necessarily occurs in or contiguous to the solution in the case of the CMR event. If the explosion occurs at some distance from the solution and merely spills the solution or shatters the container holding the solution, the source term would be reduced by at least two orders of magnitude, resulting in a release of 5 grams or less, instead of 500 grams.

Because the source term for this accident is completely driven by the assumption of a 100 percent release of the 500 grams of plutonium-239 equivalent in the solution, it is clear that any reduction in this term will directly reduce the overall source term.

Uncertainties in the source term calculation include the extent that the entire wing may be affected by the initial explosion (the SAR assumes only half of wing is involved); the fraction of material that is outside the gloveboxes/enclosures; the fraction of material in powder, solution, or less dispersible forms; and the integrity of the building confinement (e.g., glass block windows). (Building integrity affects the LPF.)

Consequences of RAD-02 for Facility Workers and the Public

The consequences of RAD-02 for facility workers and the public are discussed separately. All workers in Wing 7 at the time of the accident

could be severely injured or killed as a result of the dynamics of the explosion, the dynamics and combustion products of the fire, and exposure to plutonium-239 oxide via inhalation. Supply air for the remainder of the building is unfiltered outside air (LANL 1995c). Depending on the dynamics of the explosion release and the direction of the wind at the time of release, it is possible that air contaminated with material released from Wing 7 could be drawn into the remainder of the CMR Building and distributed to the workers in other areas of the building. This would result in inhalation exposures to those workers and contamination of other areas of the CMR Building. Due to the complications of evaluating the impact of the explosion and the resulting emergency response activities, an estimation of the worker doses is not possible with any reliability.

No acute fatalities from radiation exposure to the public are predicted to result from the postulated accident. The mean collective population dose is projected to total 120,000 person-rem (TEDE), resulting in 57 excess LCFs. Mean projected doses for MEIs (and their associated locations) and ground contamination levels are presented in Tables G.5.6.2-2 and G.5.6.2-3, respectively. Table G.5.6.2-1 summarizes the modeling results for RAD-02.

Based on re-evaluation of the meteorological conditions and the frequency of catastrophic brakes, DOE estimates the frequency for this accident now to be less than 10^{-6} (i.e., not credible) (CMR BIO, Appendix J).

G.5.6.3 *RAD-03, Power Excursion Accident with Fast Burst Assembly Outside Kiva #3*

General Scenario Description

The Godiva-IV fast-burst reactor, housed at Kiva #3 at Pajarito Site (TA-18-116), is used in a variety of experiments. This type of reactor is

TABLE G.5.6.2-1.—Summary of Results for Scenario RAD-02

ALTERNATIVE	ACCIDENT FREQUENCY	SOURCE TERM AND CONSEQUENCES
No Action	1.5×10^{-6}	504 grams plutonium-239 explosion release (60-second), 6 grams plutonium-239 fire release (2-hour), 0.48 gram plutonium-239 suspension release (24-hour); 120,000 person-rem collective exposure, resulting in 57 excess LCFs.
Expanded Operations	1.5×10^{-6}	Same as No Action Alternative.
Reduced Operations	1.5×10^{-6}	Same as No Action Alternative.
Greener	1.5×10^{-6}	Same as No Action Alternative.

^aNote: Based on re-evaluation of the meteorological conditions and the frequency of catastrophic brakes, DOE estimates the frequency for this accident now to be $<10^{-6}$ (i.e., not credible) (CMR BIO, Appendix J).

TABLE G.5.6.2-2.—Predicted Mean Doses to MEIs for Scenario RAD-02

MAXIMUM EXPOSED INDIVIDUAL (MEI) DOSE (REM, TEDE)	
MEI LOCATION	DOSE
Closest public access (SA): Diamond Road (40 m) ^a	4.0×10^3
Nearest residence (CMR SAR): Los Alamos Townsite (1,000 m)	1.7×10^2
Nearest special population distance: Los Alamos Medical Center (1,100 m)	1.5×10^2
Other nearest residences (CMR SAR): Royal Crest Trailer Park (1,200 m)	1.3×10^2
Special population distance: San Ildefonso Pueblo (4,500 m)	1.3×10^1
Special population distance: San Ildefonso Pueblo (18,600 m)	8.4×10^{-1}

^a Approximated as 50 m.

TABLE G.5.6.2-3.—Predicted Mean Ground Contamination Levels for Scenario RAD-02

RADIAL DISTANCE	PLUTONIUM-239 GROUND CONCENTRATION (BQ/m ²)
0.0 to 1.0 km	1.3 x 10 ⁶
1.0 to 2.0 km	2.5 x 10 ⁵
2.0 to 3.0 km	1.0 x 10 ⁵
3.0 to 4.0 km	5.7 x 10 ⁴
4.0 to 8.0 km	2.1 x 10 ⁴
8.0 to 12.0 km	7.6 x 10 ³
12.0 to 20.0 km	3.0 x 10 ³
20.0 to 30.0 km	1.4 x 10 ³
30.0 to 40.0 km	7.4 x 10 ²
40.0 to 60.0 km	4.0 x 10 ²
60.0 to 80.0 km	2.2 x 10 ²

BQ/m² = Becquerel per square meter

a research tool designed to provide a pulse (or burst) of neutrons for experimental purposes. Accident scenario RAD-03 involves a reactivity excursion that vaporizes a portion of the core and melts the remainder.

Godiva-IV has three 93 percent HEU control rods. One of the rods is used to adjust the burst yield, one is used for achieving a critical state, and the third is rapidly inserted in order to initiate the pulse. A fourth control element, called the safety block, provides a large reactivity shutdown for the assembly.

The assembly is operated by inserting the safety block and adjusting two of the control rods to bring the assembly to a low power steady-state condition called delayed critical. Following the achievement of delayed criticality, the control rod used for yield adjustment is set to an appropriate position for the desired pulse size. The safety block is then partially withdrawn in order to let delayed neutrons decay away for

about 15 minutes. The safety block is reinserted, and the pulse rod is rapidly inserted. The control system is designed with interlocks so that each step cannot be taken unless a precise sequence of events occurs (LANL 1996f).

Three principal potential sources of error can be identified in this process: (1) a miscalculation of the desired control-element position and the subsequent element insertion to the wrong position, (2) an incorrect position insertion based on a correct adjustment calculation, and (3) an error due to a faulty position indicator. In the first two cases, two errors are necessary. In the first case, two operators perform the calculation independently, making it unlikely that the same incorrect position could be calculated. (In addition, the operators have a logbook available to consult for past control element settings to produce the required pulse.) In the second case, the senior operator checks the final adjustment (LANL 1996f).

The effect of an operator error in the control-element adjustment could be either a larger- or smaller-than-planned superprompt critical pulse. The magnitude of the pulse is dependent on the magnitude of the error. A conditional probability factor is applied to recognize that only a small fraction of the wide range of potential pulse sizes would actually lead to reactor damage.

Another potential scenario for initiating an over-sized pulse is based upon inadvertent movement of an experiment near the reactor during the pulse operations. All equipment installed in the immediate vicinity of Godiva-IV is required to be structurally stable without support by guy wires, unattached props, or other means. However, the possibility of movement cannot be completely eliminated because the cause of movement is as varied as the experiments themselves. Because movable and remotely controllable experiments are carefully controlled and executed to avoid such movement, the most likely cause of movement

is a gravity fall of the experiment (LANL 1996f). Experiment movement during the pre-pulse waiting period is not apparent through observable system parameters (LANL 1996f).

The inadvertent movement of an experiment during the waiting period could change the reactivity of the system, which establishes the rate at which the chain reaction would occur. Depending on the magnitude of the change in the experimental setup, the additional reactivity could produce a substantial increase in the energy released during the pulse. The additional energy could be sufficient to vaporize material in the reactor. The amount of energy introduced to the system is estimated at 40.3 megajoules, which is large enough to cause fracturing, melting, or boiling of the fissile material. The vaporized material has an estimated energy of 10 percent of the total energy, or 4.0 megajoules. Thus, the vaporized material has the potential to damage the core and release an abnormal amount of fission products to the kiva building.

This accident scenario was analyzed in the TA-18 SAR. No accident sequence frequency was estimated or calculated in the SAR, nor was a frequency bin assignment made. Rather, the SAR stated that all of the accidents analyzed were incredible, implying a frequency of less than 10^{-6} per year.

The SAR source term was estimated based on the assumption that 10 percent of the 66 kilograms of uranium metal is volatilized into transportable aerosol. The release of fission products due to the pulse operation also was taken into consideration (LANL 1996f). The release fractions for fission products are specified as 100 percent for noble gases, 25 percent for halogens (e.g., iodine), and 1 percent for "semi-volatiles" (LANL 1996f). (The SAR does not describe what happens to the 90 percent of the core that does not vaporize. Analysis of a similar scenario involving the SPR-III fast-burst reactor at SNL suggests that the remainder of the core melts. Whether this

assessment is fully applicable to Godiva-IV is unclear; however, the analysis below errs on the side of conservatism, and the source term reflects the melting of the remainder of the fuel.)

No Action Alternative Frequency Analysis

This accident requires an unanticipated reactivity insertion being introduced during the time between the shutdown of the delayed-critical setup operation and the insertion of the burst reactivity. This could occur in one of two ways: (1) by operator error or a malfunction of the control systems in adding the burst reactivity increment or (2) by addition of reactivity from movement or reconfiguration of the experiment between shutdown of the delayed-critical setup operation and the insertion of the burst reactivity (LANL 1996f).

Operator error or malfunction of the control systems leading to addition to the planned burst increment can happen in three ways: (1) a miscalculation of the desired control-element position and the subsequent element insertion to the wrong position, (2) an incorrect position insertion based on a correct adjustment calculation, and (3) an error due to a faulty position indicator.

Miscalculation of Control-Element Position.

Miscalculation of the control element position requires two independent errors. In addition, the errors have to be sufficiently severe to result in an extreme power excursion. The frequency of this contributor to RAD-03 can be calculated as follows:

$$F_{\text{HEPCALC}} = F_{\text{EXP}} \times H_{\text{MISCALC}} \times H_{\text{MISCALC}} \times C_{\text{EXTREME}}$$

where:

F_{HEPCALC} = Frequency of the human error in calculation contribution to RAD-03

F_{EXP} = Annual number of Godiva-IV experiments performed

H_{MISCALC} = Human error probability for calculational error

C_{EXTREME} = Conditional probability of a large calculational error

The annual number of Godiva-IV runs for the No Action Alternative is reported to be a maximum of 80 (PC 1997).

The HEP for a miscalculation is generally in the range of 10^{-4} to 10^{-2} (Mahn et al. 1995 and Swain and Guttmann 1983). A value in the middle of that range is judged to be appropriate, considering that the most likely cause of the calculational error is entering an incorrect datum into a calculator/computer.

In addition, it should be noted that not all calculational errors are of equal severity in terms of their ability to result in scenario RAD-03. The conditional probability of such a severe calculational error, especially considering that the results can be checked with the logbook of previous burst calculations, is judged to be less than 0.01 (1 percent). (Considering the conduct of experiments under specially prepared test plans and experiment plans, an even lower value could be appropriate.)

The above equation can be solved as follows:

$$\begin{aligned} F_{\text{HEPCALC}} &= F_{\text{EXP}} \times H_{\text{MISCALC}} \times H_{\text{MISCALC}} \times C_{\text{EXTREME}} \\ &= 80 \times 0.001 \times 0.001 \times 0.01 \\ &= 8 \times 10^{-7} \text{ per year} \end{aligned}$$

Incorrect Position Insertion. This contributor to power excursions requires two human errors: the incorrect positioning action, as well as the failure of the crew chief to detect this incorrect positioning. In addition, the error must be sufficiently extreme such that the large power excursion for RAD-03 occurs.

The frequency of this contributor to RAD-03 can be calculated using the following equation:

$$F_{\text{HEPPOS}} = F_{\text{EXP}} \times H_{\text{POS}} \times H_{\text{CHK}} \times C_{\text{EXTREME}}$$

where:

F_{HEPPOS} = Frequency of the human error in mispositioning the controller

F_{EXP} = Annual number of Godiva-IV experiments performed

H_{POS} = HEP for calculational error

H_{CHK1} = HEP, check of position by supervisor

H_{CHK2} = HEP, check of position against log of previous experiments

C_{EXTREME} = Conditional probability of a large calculational error

As indicated above, the annual number of Godiva-IV runs for the No Action Alternative is a maximum of 80. The mean HEP for setting a rotary control to the wrong position is 0.001 per demand (Swain and Guttmann 1983). The HEP for the crew chief failing to detect the incorrect position indication is 0.05 per demand, based on checking that involves active participation in special measurements (Swain and Guttmann 1983). Finally, the position indication would be checked against previous experiments, providing one last opportunity to correct the error. The likelihood that this check will fail to correct the error is taken as 0.05 as well. Once the position is incorrectly set and verified, there is no additional opportunity to correct the error.

The most likely incorrect position insertion is a small deviation from normal. Such a small deviation would not yield a large enough reactivity insertion to result in accident RAD-03. Only a very large deviation would produce this accident. It is judged that the conditional probability of the error being large enough to produce the accident scenario is likely to be in the range of 0.01 per error (that is,

given an error is made, there is a 1 percent chance that the error will be of a sufficiently large magnitude to result in the accident).

The above equation can be solved as follows:

$$\begin{aligned} F_{\text{HEPPOS}} &= F_{\text{EXP}} \times H_{\text{POS}} \times H_{\text{CHK1}} \times H_{\text{CHK2}} \times \\ &\quad C_{\text{EXTREME}} \\ &= 80 \times 0.001 \times 0.05 \times 0.05 \times 0.01 \\ &= 2 \times 10^{-6} \text{ per year} \end{aligned}$$

Faulty Position Indication. The frequency of this contributor to RAD-03 can be calculated by the following equation:

$$F_{\text{IND}} = F_{\text{EXP}} \times F_{\text{RATE}} \times D_{\text{EXP}} \times H_{\text{DETECT}}$$

where:

F_{IND} = Annual frequency of faulty indicator contributor to RAD-03

F_{EXP} = Annual number of Godiva-IV experiments performed

F_{RATE} = Failure rate of the indicator per hour

D_{EXP} = Duration of experiment in hours (time in which indicator must function)

H_{DETECT} = HEP for failure of operations staff to detect the failed indicator

The annual number of Godiva-IV runs for the No Action Alternative is a maximum of 80. The type of position indicator used for the Godiva-IV machine is not specified in the SAR. Typical nuclear industry failure rates for indicator devices are in the range of 2×10^{-7} to 2×10^{-6} per hour (INEL 1990); a value in the middle of this range is assumed (7×10^{-7} per hour). It is assumed that the position indicator must read accurately for 1 hour.

The HEP for failure of the operations staff to detect the failed indicator is estimated at 0.01 per demand (based on an analogy to detecting a

failed valve that has neither position indication nor a rising stem to identify the failed state) (Swain and Guttman 1983).

The above equation can now be solved as follows:

$$\begin{aligned} F_{\text{IND}} &= F_{\text{EXP}} \times F_{\text{RATE}} \times D_{\text{EXP}} \times H_{\text{DETECT}} \\ F_{\text{IND}} &= 80 \times (7 \times 10^{-7}) \times 1 \times 0.01 \\ F_{\text{IND}} &= 6 \times 10^{-7} \text{ per year} \end{aligned}$$

Sum Total Frequency for RAD-03

The sum total frequency of RAD-03 is obtained by adding the frequency of the three contributing events as follows:

$$\begin{aligned} F_{\text{TOTAL}} &= F_{\text{HEPCALC}} + F_{\text{HEPPOS}} + F_{\text{IND}} \\ &= (8 \times 10^{-7}) + (2 \times 10^{-6}) + (6 \times 10^{-7}) \\ &= 3.4 \times 10^{-6} \text{ per year} \end{aligned}$$

Expanded Operations Alternative Frequency Analysis

The total number of pulse operations at Godiva-IV and Skua will increase for the Expanded Operations Alternative to 120 to 150 per year. We have assumed that the relative proportion of Godiva-IV versus Skua bursts will remain constant, and accordingly, have increased the frequency of RAD-03 by a factor of 1.25, to 4.3×10^{-6} per year.

Reduced Operations and Greener Alternatives Frequency Analysis

The frequency of Godiva-IV runs for the Reduced Operations and Greener Alternatives is the same as for the No Action Alternative. Thus, the frequency of accidents is the same for the Reduced Operations and Greener Alternatives as it is for the No Action Alternative.

Uncertainties and Sensitivities Affecting the Frequency of RAD-03

The frequency of RAD-03 is sensitive to the assumptions made above regarding the likelihood of various types of human errors and equipment failures.

Source Term Calculations

The accident being considered here assumes that the Godiva-IV assembly is being operated outside the confines of Kiva #3, which is occasionally done for direct radiation dose measurements to remove the effects of reflected and backscattered radiation (LANL 1996f). The SAR assumes that 10 percent of the core (6.6 kilograms of highly enriched uranium [HEU]) is vaporized, and also models the fission product release as a result of core damage and vaporization. The release fractions assumed are consistent with melting of the nonvaporized portion of the core.

The general initial source term equation will be used to evaluate the additional contribution to the source term arising from melting of the remaining 59.4 kilograms of the core (66 kilograms less 6.6 kilograms vaporized). The MAR is 66 kilograms. The damage ratio is 0.9 (the fraction of the core not vaporized). The ARF and RF values are selected based on free-fall of molten metal drops, with ARF = 0.01 and RF = 1.0 (DOE 1994d). The LPF is 1 because the release occurs outdoors. This results in an additional airborne release of HEU of:

$$\begin{aligned} \text{Initial Source Term} &= \text{MAR} \times \text{DR} \times \text{ARF} \times \text{RF} \\ &\quad \times \text{LPF} \\ &= 66,000 \times 0.9 \times 0.01 \times 1 \times 1 \\ &= 594 \text{ grams} \end{aligned}$$

The total initial source term for HEU is thus 6,600 grams + 594 grams, or a total of 7,194 grams.

The suspension source term was not calculated in the TA-18 SAR. Most of the HEU not participating in the initial release would be expected to “freeze” and not be available for release. However, this is not addressed in DOE Handbook 3010-94 (DOE 1994d). Accordingly, a conservative suspension release will be calculated by assuming that the HEU not initially released is deposited on the ground as a powder.

The suspension source term is calculated as follows:

$$\begin{aligned} \text{Suspension Source Term} &= \text{MAR} \times \text{DR} \times \\ &\quad \text{ARR/hr} \times 24 \text{ hrs} \times \text{RF} \times \text{LPF} \\ &= (66,000 - 7,194) \times 1 \times 0.00004 \times 24 \text{ hrs} \times 1 \times 1 \\ &= 56 \text{ grams} \end{aligned}$$

The release of fission products also occurs in this accident. A screening analysis was conducted of the released fission products identified by the SAR. For a release of this nature, occurring during a short fission pulse, the large majority of fission products have very short half-lives (on the order of 0.21 seconds to 3.15 minutes), and decay primarily by beta and gamma emission. The SAR analysis assigned an average dose-rate conversion factor for air immersion (cloudshine) of 4,000 millirem-cubic meters per microcurie-year. Based on the SAR radionuclide release quantities and the dose-rate conversion factor values, the dominant radionuclides were identified. Decay of the risk-dominant radionuclides to more stable progeny was evaluated. Comparison of the decay product quantities and dose conversion factors with the highly enriched uranium source term values indicated that the fission products provide a negligible contribution to the total dose from internal exposure pathways. Consequently, doses resulting from internal exposure pathways for fission products were not modeled. Doses resulting from the external exposure pathway (air immersion) for fission products (4.68×10^5 curies) were estimated

using the SAR determined average dose-rate conversion factor of 4,000 millirem-cubic meters per microcurie-year. There are no differences in source terms across the alternatives.

Uncertainties and Sensitivities Affecting the Source Term for RAD-03

The major uncertainties in the source term calculation are the 10 percent assumed vaporization of HEU as a result of the power excursion and the conservative modeling of suspension based on HEU as a powder.

Consequences of RAD-03 for Facility Workers and the Public

The consequences for facility workers and the public are discussed separately. Operations with Godiva-IV located outside Kiva #3 would be conducted during off hours with road closure controls in effect. Staffing at TA-18 would be expected to be less than during normal workday operations. The Kiva #3 control room is located 669 feet (204 meters) from the kiva (LANL 1996f). The walls of the control room are such that 40 percent attenuation of gamma doses from the outside is accomplished (LANL 1996f). In the event of an accident, ventilation systems for the control building (TA-18-30) would be secured. Air exchange with the outside would be a function of wind loading and diffusion in and around wall and ceiling penetrations (LANL 1996f). However, the ventilation system for the control building is not protected by HEPA filters (LANL 1996f).

No acute fatalities are predicted to result from the postulated accident. The mean collective population dose is projected to total 110 person-rem (TEDE), resulting in 0.06 excess fatal cancers. Mean projected doses for MEIs (and their associated locations) and ground contamination levels are presented in Tables G.5.6.3-2 and G.5.6.3-3, respectively. Table G.5.6.3-1 summarizes the modeling results for RAD-03.

G.5.6.4 *RAD-04, Inadvertent Detonation of Plutonium-Containing Assembly at DARHT*

General Scenario Description

The DARHT Facility is under construction at R site in TA-15. When completed, the facility will provide dual-axis radiographic images at the highest penetration and resolution available for the study of materials and devices under hydrodynamic conditions. DARHT was the subject of a DOE Environmental Impact Statement (DOE 1995a) and subsequent Record of Decision. The DARHT EIS included analysis of potential accidents, including bounding accidents that were selected and evaluated on a what-if basis (DOE 1995a) based on potential consequences, with little or no consideration of the frequency of occurrence, though the likelihood of occurrence would be small; in related safety analyses these accidents have been evaluated to be not credible (probability less than 10^{-6} per year) and they have been similarly identified in this SWEIS. Scenario RAD-04 represents the inadvertent uncontained detonation of plutonium-containing assembly that was evaluated as the bounding accident for all alternatives in the DARHT EIS, and is included on a similar what-if basis. Scenario RAD-11 represents the other such plutonium accident evaluated in the DARHT EIS on a what-if basis, the breach of a double-walled containment vessel.

As explained in greater detail in the DARHT EIS, the accident scenario RAD-04 involves the inadvertent detonation of high explosives and subsequent dispersal of plutonium from a plutonium-containing assembly intended for a dynamic experiment to be radiographed at DARHT (or its existing predecessor facility located a short distance away, Pulsed High-Energy Radiation Machine Emitting X-Rays

TABLE G.5.6.3-1.—Summary Results for Scenario RAD-03

ALTERNATIVE	ACCIDENT FREQUENCY	SOURCE TERM AND CONSEQUENCES
No Action	3.4×10^{-6}	7,194 grams of HEU initially, along with 4.68×10^5 Ci fission products; three, 8-hour suspension releases of 18.7 grams each; all ground level releases; results in 110 person-rem integrated population exposure and 0.06 excess LCFs.
Expanded Operations	4.3×10^{-6}	Same as No Action Alternative.
Reduced Operations	3.4×10^{-6}	Same as No Action Alternative.
Greener	3.4×10^{-6}	Same as No Action Alternative.

TABLE G.5.6.3-2.—Predicted Mean Doses to MEIs for Scenario RAD-03

MAXIMUM EXPOSED INDIVIDUAL (MEI) DOSE (REM, TEDE)	
MEI LOCATION	DOSE
Closest public access: Pajarito Road (30 m) ^a	1.5×10^2
Operations boundary (TA-18 SAR): (200 m)	1.4×10^1
Site Boundary (TA-18 SAR): San Ildefonso Pueblo boundary (1,000 m)	1.6×10^0
Special population distance: Mortandad Cave (2,900 m)	4.6×10^{-1}
Receptor distance (TA-18 SAR): Population center (4,400 m)	2.7×10^{-1}
Special population distance: San Ildefonso Pueblo (14,600 m)	5.0×10^{-2}

^a This MEI dose is provided even though for outdoor operations Pajarito Road would be closed to the public. Distance approximated as 50 m.

TABLE G.5.6.3-3.—Predicted Mean Ground Contamination Levels for Scenario RAD-03

RADIAL DISTANCE	HEU GROUND CONCENTRATION (BQ/m ²)
0.0 to 1.0 km	1.5 x 10 ⁴
1.0 to 2.0 km	1.5 x 10 ³
2.0 to 3.0 km	5.7 x 10 ²
3.0 to 4.0 km	3.0 x 10 ²
4.0 to 8.0 km	1.0 x 10 ²
8.0 to 12.0 km	3.8 x 10 ¹
12.0 to 20.0 km	1.6 x 10 ¹
20.0 to 30.0 km	7.1 x 10 ⁰
30.0 to 40.0 km	3.2 x 10 ⁰
40.0 to 60.0 km	1.5 x 10 ⁰
60.0 to 80.0 km	8.1 x 10 ⁻¹

BQ/m² = Becquerel per square meter

(PHERMEX); continued operation of PHERMEX was considered under the No Action Alternative in the DARHT EIS). PHERMEX has performed, and when completed DARHT will perform, radiography of both hydrodynamic tests and dynamic experiments (DOE 1995a).

A hydrodynamic test is a dynamic, integrated systems test of a mockup nuclear package, in which simulant materials are used to replace the fissile materials. Dynamic experiments provide information on the basic physics of materials or characterize the physical changes or motions of materials under the influence of high explosive detonations. Some dynamic experiments contain plutonium in order to obtain needed information and understanding associated with nuclear weapons aging and continued assurance of weapon safety and performance (DOE 1995a). As a matter of policy, these experiments will always be conducted inside a double-walled steel containment system consisting of an inner confinement vessel and an

outer safety vessel to prevent plutonium release; furthermore, the experiments will always be arranged and conducted in such a manner that a nuclear explosion could not result (DOE 1995a). Though some hundreds of dynamic experiments may be conducted per year, only a small number will contain plutonium (LANL 1996m).

For the RAD-04 scenario, in addition to immediate worker deaths due to the high explosive blast, human health impacts to the public are dominated by the explosive aerosolization and atmospheric dispersal of plutonium and the subsequent public exposure. Impact analysis for this SWEIS is taken directly from the DARHT EIS analysis, upon which DOE has received comment from the public; other agencies; and state, local, and tribal governments. Up to tens of excess LCFs based on a 50-year committed dose could result from this hypothetical scenario, depending on the population sector assumed to be exposed due to extant winds. For the convenience of the public and the decision maker, some of that information is also directly reproduced here and referenced to the DARHT EIS. The methodology and all impacts associated with this hypothetical, uncontained detonation scenario are principally contained in Chapter 5 and Appendixes H, I, and J of that EIS; additional information is contained in a classified appendix.

No Action Alternative Frequency Analysis

As discussed above, this accident analysis was presented in the DARHT EIS on a “what-if” basis. What-if means that regardless of the actual ability for an initiating event or accident progression to occur, the consequences of an assumed event shall be considered. For this case, the event is an uncontained detonation of a plutonium-containing assembly at the DARHT facility.

The accident was estimated to be incredible, but several related safety studies were underway

when the DARHT EIS was being completed. These studies have since been completed. The studies also support the initial estimation that the accident would be incredible (probability less than 10^{-6} per year). RAD-11 is the mitigated accident where the container is breached, and its probability is also less than 10^{-6} per year. These probabilities mean that, for these accidents, neither is expected to occur.

Nevertheless, this scenario is presented along with several other incredible accidents. These scenarios tend to demonstrate the importance and effectiveness of controls and engineering standards. The what-if scenario generally corresponds to the case where controls are assumed to have failed, and an initiating event that could cause such a consequence is assumed to be possible. When estimates are made about the probability of an initiating event occurring or the failure of multiple control barriers, then the frequencies of an inadvertent detonation become very small. The expected outcome for these experiments is a contained detonation, with a very limited probability that an inadvertent detonation will occur.

Expanded Operations, Reduced Operations, and Greener Alternatives Frequency Analysis

Because the activities at DARHT do not change across alternatives, the frequency of this scenario remains less than 10^{-6} per year.

Source Term Calculations

Detonation of an experimental assembly results in the aerosolization and potential atmospheric dispersion of a portion of the materials contained within the assembly. As described in the DARHT EIS (DOE 1995a), analysis of this hypothetical accident is documented in a classified appendix to that EIS. While the resulting impacts, as well as unclassified calculations, assumption, and modeling methods are contained in the unclassified sections of the EIS, some details of such

experiments, including some associated with the source terms for this accident scenario, are classified.

Consequences of RAD-04 for Facility Workers and the Public

Impacts to workers, noninvolved workers, public populations, and MEIs were described in the DARHT EIS. For involved workers at and around the firing site, the number of workers (and observers) when explosives are present is limited to 15; under an inadvertent detonation scenario, all of these individuals could be killed (DOE 1995a).

Predominant human health impacts to noninvolved workers or the public would stem from exposure to aerosolized and dispersed material. Impacts to noninvolved workers at distances of 2,500 and 1,300 feet (750 and 400 meters) were evaluated (DOE 1995a). Doses to noninvolved workers were estimated to be 90 rem and 160 rem for a worker at 2,500 and 1,300 feet (750 and 400 meters), respectively; corresponding probability of an excess LCF would be 0.06 and 0.04, respectively, for those individuals. LANL administratively controls access to explosives areas by noninvolved individuals and has a set of established hazard radii for protection of personnel from fragment injury from explosives experiments, based on DOE principles. It was estimated that a noninvolved worker would likely be no closer than 2,500 feet (750 meters). The public MEI located at State Road 4 was calculated to receive 76 rem, with a resulting probability of an excess LCF of 0.04 (DOE 1995a). The impacts to workers and the public MEI were summarized in Table G-10 of the DARHT EIS, which is reproduced here as Table G.5.6.4-1 for the convenience of the public. This table also includes information pertinent to the containment breach scenario RAD-11.

TABLE G.5.6.4-1.—DARHT EIS Hypothetical Impacts to Workers and the Public from Postulated Accidents Involving Plutonium

AFFECTED CATEGORY	INADVERTENT DETONATION		CONTAINMENT BREACH	
	DOSE (REM)	MAXIMUM PROBABILITY OF EXCESS LCFS	DOSE (REM)	MAXIMUM PROBABILITY OF EXCESS LCFS
Workers —	— ^a	NA	no impact	no impact
Noninvolved Workers				
750 m	90	0.04	20	0.009
400 m	160	0.06	60	0.02
Public MEI	76	0.04	14	0.007

^a No radiological impact estimated; up to 15 fatalities could result from explosion blast effects.

^b NA = Not applicable

The population exposure for the most populated sector (which includes White Rock and Santa Fe) was estimated to be between 9,000 and 24,000 person-rem for 50th and 95th percentile meteorological conditions, respectively, resulting in 5 to 12 excess LCFS (DOE 1995a). While diffusion of material across an entire directional sector was taken into account, it was assumed that all of the community populations were located at or near to the plume center line, a conservative assumption that results in an overestimate of exposures (DOE 1995a).

Population dose and impacts to other communities also were calculated using the conservative assumption that the plume passed directly over and through each hypothetically affected community (though they are generally in different directions). Because of its closeness to LANL, Los Alamos could be one of the most affected communities if the plume passed its way, calculated to receive up to 45,100 person-rem resulting in up to 22 excess LCFS (for 95th percentile meteorology). (This value could be overestimated because the airborne plume would be relatively narrow at this distance and may miss much of the population.) Other communities, including Española and the Jemez and Santa Clara Pueblos, could receive sufficient population doses under the specific

exposure conditions assumed that some excess LCFS could occur. The impacts to public populations were summarized in tables G-11 and G-12 of the DARHT EIS, which are reproduced here as Tables G.5.6.4-2 and G.5.6.4-3 for the convenience of the public. (Table G.5.6.4-2 also includes information pertinent to the containment breach scenario RAD-11.) In addition, Figure 5-1 from the DARHT EIS, which shows the most populated sector and the distribution of minority population, also is reproduced here (as Figure G.5.6.4-1).

The DARHT analysis (DOE 1995a) evaluated all significant impacts from this accident, including dispersal and human health impacts from other materials in the dynamic experiment assembly; it evaluated impacts to the public MEI, to the population, noninvolved workers, and involved workers. It used a conservative 95th percentile meteorology to various geographic population sectors, based on recent historical wind data, in calculating impacts. For atmospheric dispersion and resulting dose consequences, the DARHT EIS employed the GENII code, while other analyses in this SWEIS uses the MACCS 2 code; both codes are established for such use. The DARHT EIS also considered some different approaches to

TABLE G.5.6.4-2.—DARHT EIS Hypothetical Impacts to the Most Populated Sector from Postulated Accidents Involving Plutonium

ATMOSPHERIC DISPERSION ASSUMPTION	INADVERTENT DETONATION		CONTAINMENT BREACH	
	POPULATION DOSE (PERSON-REM)	NUMBER OF EXCESS LCFS	POPULATION DOSE (PERSON-REM)	NUMBER OF EXCESS LCFS
50 th percentile	9,000	5	210	0 (0.1)
95 th percentile	24,000	12	560	0 (0.3)

Note: The communities of Santa Fe and White Rock are included within the population of this sector.

TABLE G.5.6.4-3.—DARHT EIS Hypothetical Impacts to Nearby Communities from a Postulated Inadvertent Detonation Accident Involving Plutonium

COMMUNITY	50 TH PERCENTILE METEOROLOGY ^a		95 TH PERCENTILE METEOROLOGY ^b	
	POPULATION DOSE (PERSON-REM)	NUMBER OF EXCESS LCFS	POPULATION DOSE (PERSON-REM)	NUMBER OF EXCESS LCFS
Cochiti Pueblo	300	0	800	0
Santa Clara Pueblo	1,000	0	2,900	1
San Ildefonso Pueblo	400	0	900	0
Jemez Pueblo	600	0	4,400	2
Española	4,400	2	12,100	6
Pojoaque Pueblo	50	0	100	0
Los Alamos	5,900	3	45,100	22
White Rock	500	0	2,400	1
Santa Fe	7,500	3	18,700	9

^a 50th percentile of atmospheric dispersion conditions.

^b 95th percentile of atmospheric dispersion conditions.

Note: Values for communities in different compass directions are not additive (see Table G-6).

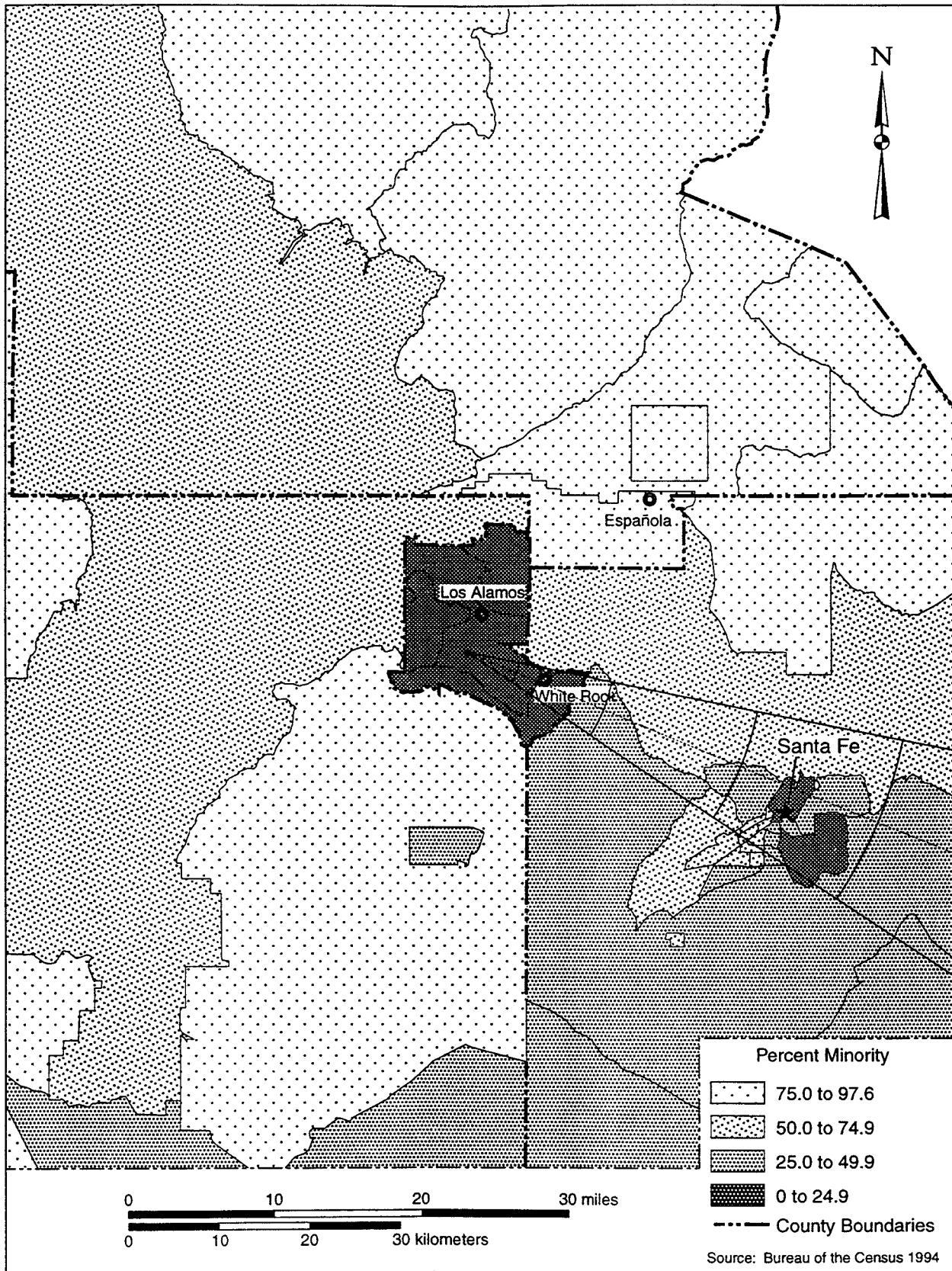

FIGURE G.5.6.4-1.—DARHT EIS Most Populated Sector and the Distribution of Minority Populations.

dispersion modeling, the results of which varied by less than a factor of 10 uncertainty in atmospheric dispersion model results that the EIS acknowledged to be ordinarily assumed for such models (DOE 1995a). As does this SWEIS, the DARHT EIS incorporated various factors and approximations to assure impact analyses are conservative, though not unduly so. Therefore, differences in models and methodology from the DARHT EIS do not affect the evaluation of the alternatives in this SWEIS.

G.5.6.5 *RAD-05, Aircraft Crash and Tritium Release at TSTA/TSFF*

General Scenario Description

The Tritium Science and Fabrication Facility (TSFF, TA-21-209) and the Tritium Systems Test Assembly (TSTA, TA-21-155) are two DOE Hazard Category 2 nonreactor nuclear facilities that handle tritium. The buildings are located in TA-21, 0.4 mile (0.6 kilometer) from and parallel to the runway of Los Alamos Airport. The buildings are about 75 feet (23 meters) apart with an intervening building (TA-21-152) separating the two facilities.

The accident scenario for RAD-05 involves an aircraft crash into TSFF and/or TSTA. Initially, it was thought that these two facilities could be modeled as a single target. However, refinement of the modeling indicated that tritium was actually likely to be present only in a small fraction of the total floor area of these two facilities. Accordingly, and in conformance with DOE Standard 3014-96 (DOE 1996c), the targets were modeled separately. Perforation/explosion was not considered to be possible at these facilities due to the lack of explosive materials. Accordingly, the scenario was limited to perforation/fire considerations. Further refinement of the crash scenarios is possible to take into account shielding of the two buildings with respect to one another,

which would reduce the crash frequencies. However, even conservatively assuming the entire facility inventory is released in oxide form, the dose consequences are somewhat modest (24 person-rem integrated population exposure and 0.0093 excess LCFs) compared with other accident scenarios evaluated in the LANL SWEIS, and further refinement was deemed to be unnecessary.

No Action Alternative Frequency Analysis

The air space above LANL is restricted up to 14,000 feet (4,270 meters), designated as Restricted Airspace R-5101 (LANL 1996c). However, DOE Standard 3014-96 states that once an in-flight mishap does occur, with eventual loss of control, there is nothing to prevent a disabled aircraft from crashing into any location, even within a restricted airspace area (DOE 1996c). The estimated frequency for perforation/fire for TSTA and TSFF is estimated at 3.8×10^{-6} and 5.3×10^{-6} per year, respectively.

Expanded Operations, Reduced Operations, and Greener Alternatives Frequency Analysis

Aircraft crash rates in the vicinity of LANL are not significantly associated with the level of activity at LANL. Accordingly, the frequency of aircraft crash does not vary by alternative.

Uncertainties and Sensitivities Affecting the Frequency of RAD-05

There is a large number of data required in order to perform the DOE Standard 3014-96 calculations. In addition, the standard itself requires the use of numerous equations that are recognized to be approximations (DOE 1996c).

Perhaps the most important uncertainty is the assumption (embedded in the standard) that a skidding aircraft will impact a facility with the same velocity it had when it began the skid. This results in a conservative impact velocity

because no credit is taken for drag, friction, impact with objects between the impact point and the facility, and so on. Other conservatisms include the assumption that the entire aircraft engine is the penetrating missile of concern. This is conservative because most of the fan shroud would tear away when striking the facility, leaving the engine shaft as the secondary penetrator.

Source Term Calculations

It was conservatively assumed that the entire inventory of the facility of interest (either TSTA or TSFF) would be released in oxide form in the event of an aircraft crash, due to fire. The MAR value for TSFF is 100 grams of tritium in process and 100 grams of tritium in storage in containers in vaults (Valentine and Pendergrass 1997). The MAR for TSTA is 200 grams (except for the Reduced Operations Alternative, for which the MAR is 150 grams). Only one building is assumed to be destroyed in a crash due to the presence of the intervening structure (TA-21-152) between TSFF and TSTA. It is assumed that in all cases the inventory of the building that is destroyed is 200 grams of tritium, released in oxide form. With the exception of TSTA in the Reduced Operations Alternative, the inventory of the destroyed building will be 200 grams. Because in the Reduced Operations Alternative there is as good a chance of hitting a 200 gram inventory building as there is hitting a 150 gram inventory building, modeling the release as 200 grams is reasonable. The standard DOE Handbook 3010-94 source term equation was employed in the source term calculation. The DR is 1 (building destruction due to explosion and fire). The ARF and RF are 1 for tritium. The LPF is also 1 due to the breach of the building by the aircraft penetration and explosion. As a result, the source term equation reduces to the MAR.

Uncertainties and Sensitivities Affecting the Source Term for RAD-05

It is assumed that there is 100 percent conversion of tritium gas to tritium oxide. This is conservative but feasible.

Consequences of RAD-05 for Facility Workers and the Public

Worker consequences and public consequences are discussed separately. A detailed worker consequence analysis was not performed; however, the following observations are made regarding the aircraft crash scenario:

- An aircraft crash that destroys the facility is assumed to result in the death of all workers in the building.
- Workers in adjacent facilities (such as the noninvolved tritium building and the intervening structure) may be injured due to flying debris from the explosion or aircraft crash, and could also be exposed to tritium oxide.

No radiation-related acute fatalities are predicted to result from the accident. The mean collective population dose is projected to total 24 person-rem (TEDE), resulting in 0.012 excess LCFs. Mean projected doses for MEIs (and their associated locations) are presented in Table G.5.6.5-2. The tritium oxide source term does not result in ground contamination. Table G.5.6.5-1 summarizes the modeling results for RAD-05.

G.5.6.6 *RAD-06, Aircraft Crash and Plutonium Release from RAMROD*

General Scenario Description

The Radioactive Materials Research, Operations, and Demonstration (RAMROD) Facility is located at TA-50-37, the site of the former treatment demonstration incineration facility. Although the RAMROD Facility has

TABLE G.5.6.5-1.—Summary Results for Scenario RAD-05

ALTERNATIVE	ACCIDENT FREQUENCY	SOURCE TERM AND CONSEQUENCES
No Action	3.8 x 10 ⁻⁶ (TSTA) 5.3 x 10 ⁻⁶ (TSFF)	200 grams of tritium as oxide; integrated population exposure of 24 person-rem, 0.012 excess LCFs.
Expanded Operations	3.8 x 10 ⁻⁶ (TSTA) 5.3 x 10 ⁻⁶ (TSFF)	Same as No Action Alternative.
Reduced Operations	3.8 x 10 ⁻⁶ (TSTA) 5.3 x 10 ⁻⁶ (TSFF)	Same as No Action Alternative. ^a
Greener	3.8 x 10 ⁻⁶ (TSTA) 5.3 x 10 ⁻⁶ (TSFF)	Same as No Action Alternative.

^aFor the Reduced Operations Alternative, the inventory at TSTA is reduced by 25 percent. The bounding consequence of 24 person-rem from a 200 gram release at TSFF is assumed.

TABLE G.5.6.5-2.—Predicted Mean Doses to MEIs for Scenario RAD-05

MAXIMUM EXPOSED INDIVIDUAL (MEI) DOSE (REM, TEDE)	
MEI LOCATION	DOSE
Closest public access: Access road to facility (10 m)	(see note)
Closest routine public access: Route 502 (360 m)	1.2 x 10 ⁻²
Closest special population: Los Alamos Airport (780 m)	2.0 x 10 ⁻²
Closest residence (TSFF SAR MEI location): Los Alamos (970 m)	1.8 x 10 ⁻²
Special population distance: San Ildefonso Pueblo boundary (2,300 m)	3.3 x 10 ⁻²
Special population distance: San Ildefonso Pueblo (14,000 m)	1.2 x 10 ⁻²

Note: For the given modeling conditions, the postulated elevated release would pass over this location before touching the ground. However, in reality this location would probably be directly impacted by the aircraft crash, and an estimation of dose would be impractical and of limited usefulness.

several uses, the most significant from the standpoint of health and safety consequences in the event of an accident is the visual characterization of TRU waste. SWEIS accident scenario RAD-06 involves an aircraft crash at RAMROD, resulting in a fire that causes the release of plutonium from TRU waste. Most of the release results from the combustible portion of the waste, which is stored in DOT Type A 55-gallon drum containers when it is not being visually examined in glovebox lines in RAMROD.

This accident is presented to provide comparisons of the aircraft crash results across LANL. The accident would have screened out based on the frequency of occurrence for such events.

Source Term Calculations

The source term calculation assumed a fire following the aircraft crash. Two aircraft types account for about 98.5 percent of the total aircraft crash frequency at RAMROD: multiple-engine piston aircraft and small military aircraft. In order to evaluate the fire potential of these aircraft, the bounding fuel load (LLNL 1996) was based on a review of the characteristics of the aircraft in these classes as identified in the supporting documentation for DOE Standard 3014-96. The aircraft selected for these classes are: (1) the Cessna Titan line, with a fuel load of 413 gallons (1,564 liters), for the multiple-engine piston aircraft; and (2) the F-16C, with a fuel load of 1,801 gallons (6,819 liters) for the small military aircraft (LLNL 1996).

In order to quantify the burn area resulting from a spill of aircraft fuel and its subsequent combustion, guidance from the Rocky Flats Risk Assessment Guide was followed that provides an estimate of a 250 square-foot (23 square-meter) burn area per 50 gallons of fuel burned (RFETS 1994). Burn areas were calculated as follows for the three significant classes of aircraft:

$$A_{\text{BURN}} = (F_{\text{LOAD}}/50) \times 250 \text{ ft}^2$$

where:

A_{BURN} = Burn area in square feet

F_{LOAD} = Aircraft fuel load in gallons

The estimated burn area for each of the significant aircraft types can now be calculated:

Multiple-Engine Piston Aircraft:

$$A_{\text{BURN}} = (F_{\text{LOAD}}/50) \times 250 \text{ ft}^2$$

$$A_{\text{BURN}} = (413/50) \times 250 \text{ ft}^2$$

$$A_{\text{BURN}} = 2,065 \text{ ft}^2$$

Small Military Aircraft:

$$A_{\text{BURN}} = (F_{\text{LOAD}}/50) \times 250 \text{ ft}^2$$

$$A_{\text{BURN}} = (1,801/50) \times 250 \text{ ft}^2$$

$$A_{\text{BURN}} = 9,005 \text{ ft}^2$$

For RAMROD, the overall area of the facility (first floor) is 15,690 square feet (1,458 square meters). The burn areas identified above represent the following percentages of the RAMROD building:

- Multiple-engine piston aircraft = 13.2 percent
- Small military aircraft = 57.4 percent

The MAR for RAMROD consists of 479 containers. These consist of 48 containers containing 75 PE-Ci each (according to the TA-54 SAR, 1 percent of LANL TRU waste containers have an inventory of 75 PE-Ci) (LANL 1995i), and 431 containers containing an average of 12 PE-Ci each (LANL 1996n). Thus, the total inventory is $(48 \times 75) + (431 \times 12) = 3,600 + 5,172 = 8,772$ PE-Ci. Given the units used in the RAMROD SAR, releases to the environment will be expressed in

grams of pure plutonium-239, rather than in grams of weapons-grade or heat-source plutonium. (The low-level mixed waste inventory is not included because the contribution to the PE-Ci inventory is trivial.)

The initial source term equation must be quantified separately for each type of aircraft contributing significantly to the crash frequency due to the difference in the impacted area of the facility. Due to the random nature of aircraft crashes, no specific directionality is associated with the crashes. The damage ratio will be expressed as the product of the percentage of the facility floor area burned in a fire (which will be assumed to equate to the fraction of the inventory affected by fire) and the fraction of the TRU waste inventory that is typically present in combustible form (0.35). This approach is equivalent to “smearing” the inventory evenly across the floor area of the building.

It is recognized that some crashes could result in a fire without affecting MAR; whereas, other crashes could burn a quantity of waste that is in excess of the fraction the floor area affected by the burn. However, the approach adopted above is believed to yield a reasonable result that is considered to be representative of the average that would result from a large number of crashes.

The ARF and RF values are selected from DOE Handbook 3010-94 and are based on the bounding values for packaged mixed combustible waste. The recommended ARF and RF values are 0.0005 and 1.0 (DOE 1994d). For the noncombustible waste, the ARF and RF values are 0.006 and 0.01 (DOE 1994d). Due to the penetration of the building by the aircraft-related missiles and/or due to external or internal explosion of fuel, the LPF is taken to be 1.0.

The general initial source term equation is quantified below for the two aircraft types that

contribute to the crash frequency, as well as for both combustible and noncombustible waste forms:

Multiple-Engine Piston Aircraft:

$$\begin{aligned} \text{Initial Combustible Source Term} &= \text{MAR} \times \text{DR} \\ &\quad \times \text{ARF} \times \text{RF} \times \text{LPF} \\ &= 8,772 \times (0.132 \times 0.35) \times 0.0005 \times 1 \times 1 \\ &= 0.2 \text{ PE-Ci} \end{aligned}$$

$$\begin{aligned} \text{Initial Noncombustible Source Term} &= \text{MAR} \times \\ &\quad \text{DR} \times \text{ARF} \times \text{RF} \times \text{LPF} \\ &= 8,772 \times (0.132 \times 0.65) \times 0.006 \times 0.01 \times 1 \\ &= 0.05 \text{ PE-Ci} \end{aligned}$$

$$\begin{aligned} \text{Multiple-Engine Piston Initial Source Term} \\ \text{Total} &= \text{Initial Combustible} + \text{Initial} \\ &\quad \text{Noncombustible} \end{aligned}$$

$$= 0.2 + 0.05$$

$$= 0.25 \text{ PE-Ci}$$

Small Military Aircraft:

$$\begin{aligned} \text{Initial Combustible Source Term} &= \text{MAR} \times \text{DR} \\ &\quad \times \text{ARF} \times \text{RF} \times \text{LPF} \\ &= 8,772 \times (0.574 \times 0.35) \times 0.0005 \times 1 \times 1 \\ &= 0.88 \text{ PE-Ci} \end{aligned}$$

$$\begin{aligned} \text{Initial Noncombustible Source Term} &= \text{MAR} \times \\ &\quad \text{DR} \times \text{ARF} \times \text{RF} \times \text{LPF} \\ &= 8,772 \times (0.574 \times 0.65) \times 0.006 \times 0.01 \times 1 \\ &= 0.20 \text{ PE-Ci} \end{aligned}$$

$$\begin{aligned} \text{Air Taxi Aircraft Initial Source Term Total} &= \\ &\quad \text{Initial Combustible} + \text{Initial Noncombustible} \end{aligned}$$

$$= 0.88 + 0.20$$

$$= 1.08 \text{ PE-Ci}$$

Following the initial source term release, resuspension releases are possible due to dispersal of material by the wind. For an aircraft crash, a 24-hour suspension release is reasonable due to the significant damage resulting from the aircraft crash and subsequent explosion and fire.

The general suspension source term equation is used. The DR is simply the fraction of the area burned because the ARR/hr and RF values are the same for both combustible and noncombustible waste. The ARF and RF values are selected from DOE Handbook 3010-94 and are based on the bounding values for packaged mixed waste. The recommended ARR and RF values are 4×10^{-5} per hour and 1.0 (DOE 1994d). Due to the penetration of the building by the aircraft-related missiles and/or due to external or internal explosion of fuel, the LPF is taken to be 1.0. It is assumed that temporary confinement cannot be erected or otherwise established for 24 hours to control suspension releases.

The suspension source term equation also must be quantified individually for each of the two crash frequency contributors:

Multiple-Engine Piston Aircraft:

$$\begin{aligned} \text{Suspension Source Term} &= \text{MAR} \times \text{DR} \times \\ &\quad \text{ARR/hr} \times 24 \text{ hrs} \times \text{RF} \times \text{LPF} \\ &= 8,772 \times 0.132 \times 0.00004 \times 24 \times 1 \times 1 \\ &= 1.1 \text{ PE-Ci} \end{aligned}$$

Small Military Aircraft:

$$\begin{aligned} \text{Suspension Source Term} &= \text{MAR} \times \text{DR} \times \\ &\quad \text{ARR/hr} \times 24 \text{ hrs} \times \text{RF} \times \text{LPF} \\ &= 8,772 \times 0.574 \times 0.00004 \times 24 \times 1 \times 1 \\ &= 4.8 \text{ PE-Ci} \end{aligned}$$

In order to specify a single source term for the RAMROD aircraft crash accident, the initial

source terms and suspension source terms are frequency-weighted according to their contributions to the overall risk, as shown in Tables G.5.6.6-1 and G.5.6.6-2.

Based on these calculations, the source term for RAD-06 for the No Action Alternative is represented with an initial source term of 0.63 PE-Ci released in 30 minutes, and a suspension source term of 2.8 PE-Ci released over 24 hours.

There are no differences in source term across the alternatives because the No Action Alternative source terms are based on the RCRA-permitted capacity of the building.

Uncertainties and Sensitivities Affecting the Source Term for RAD-06

The source terms (initial and suspension) are maximum values, based on the RCRA-permitted capacity of the building. At any given time, there may be less TRU waste in the building than the permitted capacity. The average amount of TRU waste in combustible form may vary (an average value was used).

The suspension source term calculation extends for 24 hours. This may be very conservative in that it is likely that fire fighting and hazardous material (HAZMAT) response to the crash scene would be accompanied by extensive use of water and foam-based suppression systems. This application of suppressants would likely continue for some time to preclude flareup of the fire once it is extinguished, as well as to limit further spread of airborne plutonium contamination. Thus, the suspension source term may be very conservatively estimated for this scenario.

Consequences of RAD-06 for Facility Workers and the Public

Consequences for facility workers and the public are reported separately. An aircraft crash into the facility that destroys part of the facility is assumed to result in the death of all workers

TABLE G.5.6.6-1.—Frequency Weighted Source Term Calculation for Initial Source Term

AIRCRAFT TYPE	PERCENTAGE CONTRIBUTION TO AIRCRAFT CRASH FREQUENCY	INITIAL SOURCE TERM (PLUTONIUM-239 PE-Ci)	WEIGHTED INITIAL SOURCE TERM (PLUTONIUM-239 PE-Ci)
Multiple-Engine Piston	52.3%	0.25	0.13
Small Military	46.2%	1.08	0.50
TOTAL	98.5%		0.63

TABLE G.5.6.6-2.—Frequency Weighted Source Term Calculation for Suspension Source Term

AIRCRAFT TYPE	PERCENTAGE CONTRIBUTION TO AIRCRAFT CRASH FREQUENCY	SUSPENSION SOURCE TERM (PLUTONIUM-239 PE-Ci)	WEIGHTED SUSPENSION SOURCE TERM (PLUTONIUM-239 PE-Ci)
Multiple-Engine Piston	52.3%	1.1	0.58
Small Military	46.2%	4.8	2.22
TOTAL	98.5%		2.80

in the part destroyed. Workers elsewhere in the structure may be injured or killed due to flying debris or secondary effects from the fire (e.g., smoke inhalation). Workers in the building who are not directly affected by the crash and explosion or fire may be exposed to radiation as a result of plutonium inhalation. If the building collapses as a result of the impact of the aircraft, additional injuries or fatalities could result.

No acute fatalities are predicted to result from the postulated accident. The mean collective population dose is projected to total approximately 7,900 person-rem (TEDE), resulting in 4.2 excess LCFs. No ground contamination results or MEI doses are presented because the accident is incredible. Table G.5.6.6-3 summarizes the modeling results for RAD-06.

G.5.6.7 RAD-07, TRU Waste Container Storage Area Fire at WCRR Facility

General Scenario Description

The Waste Characterization, Reduction, and Repackaging (WCRR) Facility performs a variety of activities related to characterization, volume reduction, and repackaging, primarily for TRU waste. In order to support these activities, an outdoor Container Storage Area is provided just to the south of the WCRR Facility main building. Accident scenario RAD-07 involves a fire at the Container Storage Area, resulting in the release of plutonium from the TRU waste (which is contained in DOT Type A 55-gallon drums). The Container Storage Area has a RCRA Part B permitted capacity of 30,000 gallons of mixed waste, which is equivalent to 545, 55-gallon drums. WCRR Facility also has a RCRA Part B permitted capacity of 1,500 gallons of mixed waste (equivalent to 27, 55-gallon drums).

TABLE G.5.6.6-3.—Summary Results for RAD-06

ALTERNATIVE	ACCIDENT FREQUENCY	SOURCE TERM AND CONSEQUENCES
No Action	6.5×10^{-8}	Initial release of 0.63 PE-Ci, released in 30 minutes; Suspension source term of 2.8 PE-Ci, released over 24 hours; integrated population exposure of 7,900 person-rem and 4.2 excess LCFs.
Expanded Operations	6.5×10^{-8}	Same as No Action Alternative.
Reduced Operations	6.5×10^{-8}	Same as No Action Alternative.
Greener	6.5×10^{-8}	Same as No Action Alternative.

RAD-07 Release Mechanisms

The postulated RAD-07 accident scenario involves an airborne release of radioactive material due to a fire that develops at the outdoor container storage area. Potential accident initiators include: (1) truck fires, (2) forklift fires, (3) external fires (wild fires), (4) lightning strikes, and (5) aircraft accidents. Lightning may strike the Container Storage Area or pose an indirect hazard by initiating a wildfire. The Container Storage Area does not have lightning protection; however, a lightning strike would, at most, pose a localized hazard due to ignition of combustible waste. It would have a very limited opportunity to propagate with waste contained in metal drums and the low combustible loading of the storage array. Wild fires, initiated by lightning strikes or otherwise, do not pose a significant hazard considering the developed nature of the area (e.g., pavement), the low vegetation loading of the immediate surrounding area, and the time available to take mitigative actions. A forklift fire would be credible, but would be significantly bounded by the MAR for a truck fire accident.

Two truck fire scenarios could occur. The first is an accident involving a truck that causes a fuel leak and subsequent fire involving the Container Storage Area. This is judged not to be credible considering the low truck speeds involved in the confined yard area and the

limited vehicle traffic, with the exception of forklift activity. The second involves a truck parked near the Container Storage Area that could experience a fuel system leak or fuel tank leak due to causes unrelated to a vehicle accident. Once a fuel leak occurs, ignition of the spilled fuel would lead to a fire that, if it is close enough to the Container Storage Area and if it is not suppressed, would envelope multiple waste containers. This scenario is retained for analysis.

While not required by the RCRA Part B permit, waste drums are currently stored in transportables for weather protection. The analysis takes no credit for the separation provided by the transportables because the RCRA Part B permit does not require their use. This accident was not evaluated in the WCRR Facility SAR (LANL 1995e).

No Action Alternative Frequency Analysis

The frequency (F_{FIRE}) of a truck fuel leak and subsequent fire accident can be estimated using the following equation:

$$F_{\text{FIRE}} = N_{\text{SHIPMENTS}} \times C_{\text{LEAK}} \times C_{\text{PFIRE}}$$

where:

$N_{\text{SHIPMENTS}}$ = Number of shipments to or from the Container Storage Area at TA-50-69 per year

C_{LEAK} = Conditional probability of fuel leak per shipment

C_{PFIRE} = Conditional probability of a fire given a fuel leak

The frequency of a fuel system leak or fuel tank leak and a resulting fire is assessed for the Container Storage Area at TA-50-69 based on methods and data described in section G.5.10, RAD-01. The per trip fuel leak rate is 1.3×10^{-3} per trip, with 24 shipments per year assumed for the purposes of analysis (2 shipments per month). Thus, the above equation can be quantified as follows:

$$F_{FIRE} = N_{SHIPMENTS} \times C_{LEAK} \times C_{PFIRE}$$

$$F_{FIRE} = 24 \times (1.3 \times 10^{-3}) \times (4.7 \times 10^{-3})$$

$$F_{FIRE} = 1.5 \times 10^{-4} \text{ per year}$$

In order to assure that the frequency of a fire due to forklift activity was dominated by the truck fire scenario, the frequency of a forklift fire was estimated. The frequency of a forklift fire ($F_{FLFTFIRE}$) leading to a release of TRU material at the Container Storage Area may be analyzed using the following equation:

$$F_{FLFTFIRE} = N_{FMOVE} \times N_{HOUR} \times F_{FUEL} \times C_{PING}$$

where:

N_{FMOVE} = Number of forklift movements per year

N_{HOUR} = Number of hours per forklift movement adjacent to Container Storage Area

F_{FUEL} = Frequency of a fuel tank rupture per hour

C_{PING} = Conditional probability of ignition given a fuel tank rupture

Forklift movements at TA-50-69 occur on an individual drum basis and on a palletized basis

at the time of receipt and shipment. The WCRR Facility SAR (LANL 1995e) estimates 200 movements of palletized drums per year. Individual drum movements are not evaluated in the SAR. However, based on four drums per pallet, two palletized movements per set of four drums (for unloading and loading), and that individual drum movements would occur when waste drums are brought to and returned from the WCRR Facility, it is estimated that there are 800 ($[200/2] \times 2 \times 4$) individual drum movements per year.

The frequency of a forklift fuel tank rupture and a resulting fire is assessed based on methods and data contained in the TA-54, Area G Hazard Analysis (LANL 1995g), which references the evaluation of ignition probabilities given a tank rupture by the Reliability Analysis Center (RAC 1991). The frequency of a fuel tank rupture was assessed as 2.3×10^{-5} per hour in the TA-54 hazard analysis (LANL 1995g). For a nondiesel fuel (propane), the conditional probability of ignition given a rupture is assigned a value of 1×10^{-2} . It is conservatively assumed that each forklift movement lasts 0.5 hour. For individual drum movements, it is assumed the forklift movement time is equally divided at the Container Storage Area, in transit to the facility, and at the facility. For the palletized movements, it is assumed that the forklift time is equally spent immediately near the Container Storage Area and at the truck. Because of the small fuel capacity of the forklift as compared with the truck, it is assumed that any forklift incidents at the truck would not involve the Container Storage Area. Additionally, it is noted that forklift activities would be in the vicinity of the truck bed and, thus, would not involve the truck/tractor fuel tanks.

Thus, the above equation for forklift movements near the Container Storage Area can be quantified as follows:

$$F_{\text{FLFTFIRE}} = N_{\text{FMOVE}} \times N_{\text{HOUR}} \times F_{\text{FUEL}} \times C_{\text{PING}}$$

$$= [800 \text{ moves} \times (0.5/3 \text{ hr/move}) + 200 \text{ moves} \times (0.5/2 \text{ hr/move})] \times (2.3 \times 10^{-5} / \text{hr}) \times (1 \times 10^{-2})$$

$$= 4.2 \times 10^{-5} \text{ per year}$$

The calculated frequency for a forklift fire involving the Container Storage Area is less than that for a truck fire. Additionally, the MAR for a postulated forklift fire would be much less than that for a truck fire. Consequently, truck fires dominate potential risks and forklift fire contributions are not considered further.

Expanded Operations Alternative Frequency Analysis

The Expanded Operations Alternative waste management practices and the low-level radioactive mixed waste (LLMW) generation rate will be comparable to the No Action Alternative. However, TRU waste volumes are expected to double (5,100 versus 2,500 cubic meters) from those in the No Action Alternative (LANL 1997c). On this basis, it is expected that waste throughput at WCRR Facility and the associated frequency of a potential truck fire at the Container Storage Area will be greater than in the No Action Alternative. Historically, WCRR Facility activities have primarily involved TRU waste characterization and volume reduction. Consequently, it is assumed that the change in throughput at WCRR Facility will be directly proportional to the change in TRU waste volume, resulting in 49 shipments per year ($24 \times 5,100/2,500$).

With a revised number of truck shipments for the Expanded Operations Alternative, the frequency (F_{FIRE}) of a truck fuel leak and subsequent fire accident can be estimated as:

$$F_{\text{FIRE}} = N_{\text{SHIPMENTS}} \times C_{\text{LEAK}} \times C_{\text{PFIRE}}$$

$$F_{\text{FIRE}} = 49 \times (1.3 \times 10^{-3}) \times (4.7 \times 10^{-3})$$

$$F_{\text{FIRE}} = 3.0 \times 10^{-4} \text{ per year}$$

Reduced Operations Alternative Frequency Analysis

For the Reduced Operations Alternative, waste management practices and the LLMW waste generation rate will be comparable to the No Action Alternative. However, TRU waste volumes are expected to be almost 25 percent less (1,900 versus 2,500 cubic meters) than those for the No Action Alternative (LANL 1997c). On this basis, it is expected that waste throughput at WCRR Facility and the associated frequency of a potential truck fire at the Container Storage Area will be less than in the No Action Alternative. Historically, WCRR Facility activities have primarily involved TRU waste characterization and volume reduction. Consequently, it is assumed that the change in throughput at WCRR Facility will be directly proportional to the change in TRU waste volume, resulting in 18 shipments per year ($24 \times 1,900/2,500$).

With a revised number of truck shipments for the Reduced Operations Alternative, the frequency (F_{FIRE}) of a truck fuel leak and subsequent fire accident can be estimated as:

$$F_{\text{FIRE}} = N_{\text{SHIPMENTS}} \times C_{\text{LEAK}} \times C_{\text{PFIRE}}$$

$$F_{\text{FIRE}} = 18 \times (1.3 \times 10^{-3}) \times (4.7 \times 10^{-3})$$

$$F_{\text{FIRE}} = 1.1 \times 10^{-4} \text{ per year}$$

Greener Alternative Frequency Analysis

For the Greener Alternative, waste management practices and waste generation rates for LLMW and TRU waste will be comparable to those for the No Action Alternative. On this basis, it is expected that waste throughput at WCRR Facility and the associated frequency of a potential truck fire at the Container Storage Area will be the same as in the No Action Alternative.

Uncertainties and Sensitivities Affecting the Frequency of RAD-07

Insofar as the fire modeling is concerned, the uncertainties affecting the frequency of RAD-07 are identical to those affecting CHEM-02. The frequency results are also sensitive to the assumed number of shipments per year for the Container Storage Area.

Source Term Calculations

The initial source term equation is used for this case. The MAR for the postulated accident is limited to the Container Storage Area waste inventory immediately involved in the truck fuel pool fire. Propagation of the fire to the entire inventory is not expected, as discussed in section G.5.16.1. The MAR is estimated for a 100-gallon (379-liter) fuel spill, yielding a burn area of 500 square feet (46 square meters). This is based on a burn area relationship of 250 square feet for 50 gallons of fuel (23 square meters for 189 liters of fuel) (RFETS 1994). Assuming that half the burn area is off center from the Container Storage Area and that half the remaining area involves waste (allows for aisle/access space), approximately 62 drums (stacked two high) would be involved (125 square feet x 2 drums/4 square feet).

Potential waste forms present include solidified liquids (aggregate); surface contaminated, packaged combustible solids; and surface contaminated, noncombustible solids. The bounding ARF and RF products for these three waste forms in a thermal stress environment (fire) are 6×10^{-5} , 5×10^{-4} , and 6×10^{-5} , respectively (DOE 1994d). Consequently, it can be concluded that releases will be dominated by combustible waste and the analysis will be limited to this waste form. It is conservatively assumed that the combustible waste fraction at the Container Storage Area is the same as that for the TRU waste inventory at Area G. The Container Storage Area combustible waste fraction is likely to be much lower due to the facility's primary mission of

size reduction of metal objects, such as gloveboxes; however, combustible waste forms would be expected to be present due to characterization activities. Additionally, it is conservatively assumed that 35 percent of the radiological inventory is present in combustible waste forms. Thus, for the MAR (62 drums), the DR is set equal to the fraction of combustible material (0.35). The Container Storage Area is located outdoors; consequently, any postulated accident involving a release to the environment would have an LPF of 1.0.

Proposed administrative limits for the radionuclide content of each individual waste container are presented in Table 9-2 of the WCCR Facility SAR (LANL 1995e) and are based on DOE Standard 1027-92 (DOE 1992) Hazard Category 3 threshold limits or a fissile gram equivalent limit based on the WIPP WAC. Currently, the average TRU radioactive material content per waste container is 8.9 PE-Ci (LANL 1995f). Less than 1 percent of all TRU waste containers in the existing Area G inventory exceed 75 PE-Ci in radioactive material content (LANL 1995f). The predominant TRU waste generated at LANL is weapons-grade plutonium (MT52). The LANL fissile gram equivalent limit for this material type is 25 PE-Ci per drum (LANL 1995f). Revision 5 of the WIPP WAC limits the maximum plutonium-239 equivalent activity for untreated, contact-handled TRU waste to be received by the facility to 80 PE-Ci per drum. Considering that the postulated accident scenario involves multiple drums (62); that the drums represent a small fraction of the total TRU waste inventory managed at LANL, and their radioactive content could be skewed to the high end (depending on the waste generator source); and the TRU limits described above; it is conservatively assumed that one drum contains the WIPP WAC limit for untreated waste of 80 PE-Ci and the other 61 drums involved in the fire have an average TRU content of 25 PE-Ci.

With the above information, the initial source term equation can be quantified as follows:

$$\begin{aligned} \text{Initial Source Term} &= \text{MAR} \times \text{DR} \times \text{ARF} \times \text{RF} \\ &\quad \times \text{LPF} \\ &= ([61 \times 25 \text{ PE-Ci}] + 80 \text{ PE-Ci}) \times 0.35 \times \\ &\quad (5 \times 10^{-4}) \times 1 \times 1 \\ &= 0.28 \text{ PE-Ci} \end{aligned}$$

The suspension source term calculation is performed using the general equation. The suspension MAR equals the initial MAR, minus the initial source term. The suspension DR and LPF have the same values (1.0) as in the initial source term calculation. The ARR and RF are assigned values of 4×10^{-5} and 1.0, respectively, based on bounding resuspension factors for a homogeneous bed of powder exposed to ambient conditions (DOE 1994d). Thus, the suspension source term can be quantified as:

$$\begin{aligned} \text{Suspension Source Term} &= \text{MAR} \times \text{DR} \times \text{ARR} \\ &\quad \times 24 \text{ hrs} \times \text{RF} \times \text{LPF} \\ &= (1,550 - 0.28 \text{ PE-Ci}) \times 0.35 \times (4 \times 10^{-5}) \times \\ &\quad 24 \text{ hrs} \times 1 \times 1 \\ &= 0.52 \text{ PE-Ci} \end{aligned}$$

The suspension source term is highly conservative, considering that fire protection actions (e.g., foam, water spray) and contamination control measures would likely limit airborne releases significantly.

No variation by alternative is projected because waste management practices are expected to be comparable (LANL 1997c), with the MAR and postulated accident conditions the same.

Uncertainties and Sensitivities Affecting the Source Term for RAD-07

A significant uncertainty for this postulated accident is quantification of the MAR in terms of the number of drums involved in the fire and their associated radioactive material content.

Accepted methodologies and reasonably conservative radiological estimates have been made to provide an upper estimate of the source term.

Consequences of RAD-07 for Facility Workers and the Public

Typically, five facility workers are associated with TA-50-69 operations and would be at risk for exposure to airborne radioactive material. The postulated accident would not result in an immediate release, providing time for personnel to vacate the immediate area. Personnel in the facility may not have time to vacate before a release occurs; however, CAM alarms and the availability of personal protective equipment could serve to mitigate potential exposures.

No acute fatalities are predicted to result from the postulated accident. The mean collective population dose is projected to total 1,300 person-rem (TEDE), resulting in 0.69 excess LCFs. Mean projected doses for MEIs (and their associated locations) and ground contamination levels are presented in Tables G.5.6.7-2 and G.5.6.7-3, respectively. Table G.5.6.7-1 summarizes the modeling results for RAD-07.

G.5.6.8 RAD-08, Aircraft Crash and Plutonium Release from TA-54 TWISP Storage Domes

General Scenario Description

Accident Scenario RAD-08 involves the crash of an aircraft, accompanied by explosion and/or fire, at the TRU waste management area of TA-54, Area G. The largest target, which dominates the aircraft crash frequency results and also has a very large potential MAR, consists of the storage domes for the Transuranic Waste Inspectable Storage Project (TWISP).

TABLE G.5.6.7-1.—Summary Results for Scenario RAD-07

ALTERNATIVE	ACCIDENT FREQUENCY	SOURCE TERM AND CONSEQUENCES
No Action	1.5×10^{-4}	Initial release of 0.28 PE-Ci; Suspension release of 0.52 PE-Ci; integrated population exposure of 1,300 person-rem, 0.69 excess LCFs.
Expanded Operations	3.0×10^{-4}	Same as No Action Alternative.
Reduced Operations	1.1×10^{-4}	Same as No Action Alternative.
Greener	1.5×10^{-4}	Same as No Action Alternative.

TABLE G.5.6.7-2.—Predicted Mean Doses to MEIs for Scenario RAD-07

MAXIMUM EXPOSED INDIVIDUAL (MEI) DOSE (REM, TEDE)	
MEI LOCATION	DOSE
Closest public access: Pajarito Road (100 m)	7.4×10^1
Special population distance: San Ildefonso Pueblo boundary (500 m)	3.5×10^0
Closest public residence: Royal Crest Trailer Park (1,200 m)	7.4×10^{-1}
Closest special population distance: Ashley Pond (2,100 m)	2.6×10^{-1}
Special population distance: San Ildefonso Pueblo (13,600 m)	1.4×10^{-2}

TABLE G.5.6.7-3.—Predicted Mean Ground Contamination Levels for Scenario RAD-07

RADIAL DISTANCE	PLUTONIUM-239 GROUND CONCENTRATION (BQ/m ²)
0.0 to 1.0 km	1.7×10^4
1.0 to 2.0 km	1.7×10^3
2.0 to 3.0 km	6.7×10^2
3.0 to 4.0 km	3.8×10^2
4.0 to 8.0 km	1.8×10^2
8.0 to 12.0 km	9.3×10^1
12.0 to 20.0 km	5.5×10^1
20.0 to 30.0 km	2.9×10^1
30.0 to 40.0 km	1.6×10^0
40.0 to 60.0 km	9.3×10^0
60.0 to 80.0 km	4.9×10^0

BQ/m² = Becquerel per square meter

TRU waste is stored in aluminum arch-frame supported, membrane-covered domes that rest on asphalt pads. Four domes are in use as storage for TRU waste generated since the early part of 1991, designated as TA-54-48, TA-54-153, TA-54-224, and TA-54-283. The storage capacity is 11,000 drums, and there were 3,600 drums in storage as of the end of 1995.

Previously, from 1979 to 1991, TRU waste was stored in retrievable arrays under several feet of earth on three pads (Pads 1, 2, and 4). This retrievable TRU waste is being removed from this configuration and temporarily placed into storage dome structures. The retrieved waste is characterized, repackaged, and certified to WIPP WAC. (All of the retrievable TRU waste is planned to be shipped to WIPP after 1998.) Once the retrieved waste is characterized, repackaged, and WIPP WAC-certified, it will be stored in one of six dome structures, designated as TA-54-229, TA-54-230, TA-54-231, and TA-54-232 (plus two domes yet to be constructed). The four domes are located adjacent to one another at the far eastern extent of the TA-54 operating area; the other two domes will be located at a distance from the four TWISP domes so as to constitute a separate target area, the contribution to risk of which will be bounded by the four existing TWISP storage domes.

The characteristics of the TRU waste to be retrieved from Pads 1, 2, and 4 are generally known as detailed in Table G.5.6.8-1 (LANL 1996n). There are a total of 16,641 drums: 5,487 drums of combustible waste containing an average of 4.34 PE-Ci of plutonium-239 each, and 11,154 drums of noncombustible waste containing an average of 4.11 PE-Ci of plutonium-239 each. There are also 187 fiberglass-reinforced plastic-coated plywood (FRP) crates: 33 FRP crates of combustible waste containing an average of 12.5 PE-Ci of plutonium-239 each, and 154 FRP crates of noncombustible waste containing an average of 8.6 PE-Ci of plutonium-239 each. The total

TABLE G.5.6.8-1.—Characterization of TRU Waste in Pads 1, 2, and 4 at TA-54 Area G

TRU PAD #1, USED FROM 5/29/79 TO 12/29/81
4,816 Drums
1,276 drums of combustible waste containing 2,240 PE-Ci of plutonium-239
3,540 drums of noncombustible waste containing 4,400 PE-Ci of plutonium-239
88 FRP Crates
8 FRP crates of combustible waste containing 2.03 PE-Ci of plutonium-239
80 FRP crates of noncombustible waste containing 1,170 PE-Ci of plutonium-239
TRU PAD #2, USED FROM 12/8/81 TO 8/20/85
7,280 Drums
2,475 drums of combustible waste containing 6,890 PE-Ci of plutonium-239
4,805 drums of noncombustible waste containing 17,100 PE-Ci of plutonium-239
48 FRP Crates
22 crates of combustible waste containing 1.47 PE-Ci of plutonium-239
26 crates of noncombustible waste containing 60.3 PE-Ci of plutonium-239
TRU PAD #4, USED FROM 3/18/85 TO 1/3/91
4,545 Drums
1,736 drums of combustible waste containing 14,700 PE-Ci of plutonium-239
2,809 drums of noncombustible waste containing 24,300 PE-Ci of plutonium-239
51 FRP Crates
3 FRP crates of combustible waste containing 410 PE-Ci of plutonium-239
48 FRP crates of noncombustible waste containing 91.9 PE-Ci of plutonium-239

inventories of the three pads are: 7,812 PE-Ci of plutonium-239 for Pad 1; 24,052 PE-Ci of plutonium-239 for Pad 2; and 39,502 PE-Ci of plutonium-239 for Pad 4. In total, the FRP crates represent 1,736 PE-Ci of plutonium-239, or about 2.4 percent of the total TRU waste inventory.

No detailed apportionment of the TRU waste recovered from Pads 1, 2, and 4 among the four domes (TA-54-229, TA-54-230, TA-54-231, and TA-54-232) have been identified. For the purposes of this analysis, it is assumed that the TWISP TRU inventory, in terms of PE-Ci, is split evenly among the six domes. Thus, each dome is assumed to contain 4,041 PE-Ci of Plutonium-239 as combustible TRU waste and 7,854 PE-Ci of noncombustible TRU waste.

At the average content values identified above, this would represent about 931 drums of combustible TRU waste and 1,911 drums of noncombustible TRU waste. (This is a slight over-estimate, but considered to be reasonable considering possible repackaging.)

In the storage domes, TRU waste drums are palletized (four drums to a pallet) and stored in inspectable arrays. The arrays consist of palletized drums stacked three high, separated by a minimum aisle space of 26 inches (66 centimeters). FRP crates and standard waste boxes (SWBs) are also stored in these structures. FRP crates and SWBs are stored in rows and stacked one to three boxes high (LANL 1995f). LANL is in the process of exchanging plywood pallets for metal pallets to reduce fire hazards in the TRU waste domes.

Fire-fighting water for Area G is provided by a 10-inch main from a water distribution system supplied by two water tanks near TA-54. The primary tank is a gravity feed with a 1.5 million gallon domestic booster pump (booster station 2). The secondary tank is a pressure feed with a 1.5 million gallon domestic booster pump (booster station 1). Water mains are designed to provide 1,170 gallons per minute at the fire hydrants with a residual pressure of 20 psi (LANL 1996n). Fire-fighting equipment can arrive at TWISP operations in 8 to 12 minutes. The initial response is two pumpers capable of dispensing 1,250 gallons per minute with a 500-gallon onboard storage capacity each, one light rescue vehicle, and one staff vehicle. An

additional pumper is available on the second alarm (LANL 1996n).

In addition to fire-fighting response, LANL ESH-10 maintains a HAZMAT team at TA-64. The HAZMAT team would respond to an accident such as an aircraft crash at TA-54 Area G.

The TA-54 Area G SAR did not evaluate aircraft crash accidents. Aircraft crash at a TRU waste dome was identified in the TA-54 Area G Hazard Analysis with a frequency assigned as below 1×10^{-6} per year based on expert judgment (LANL 1995g).

A separate LANL study evaluated aircraft crash frequency at TA-54 by calculating the crash frequency for the largest building at the site, which is one of the TWISP fabric domes at 320 feet (98 meters) long, 246 feet (75 meters) wide, and 38 feet (12 meters) high. The study calculated the aircraft crash at 1.02×10^{-8} per year (LANL 1996c).

No Action Alternative Frequency Analysis

The air space above LANL is restricted up to 14,000 feet, designated as Restricted Airspace R-5101 (LANL 1996c). However, DOE Standard 3014-96 states that once an in-flight mishap does occur, with eventual loss of control, there is nothing to prevent a disabled aircraft from crashing into any location, even within a restricted airspace area (DOE 1996c).

The TRU waste storage domes at TA-54 Area G were reviewed. As a result of their locations, TA-54-153 and TA-54-283 are essentially a single target (they are separated by less than 100 feet [31 meters]); TA-54-283 is a temporary structure.

TA-54-224 represents another target (separated from TA-54-283 and TA-54-153 by over 100 feet (31 meters). TA-54-48 is still another stand-alone target, being more than 100 feet (31 meters) from the TA-54-229 through

TA-54-232 group of domes. TA-54-229 through TA-54-232 represent a single target as they are adjacent to one another separated by less than 50 feet (15 meters) between the domes.

The TWISP retrieval dome, as well as the two temporary domes used to house TWISP waste after retrieval but before repackaging (TA-54-224 and TA-54-283), are all temporary structures. The only permanent structures will be the two existing domes used to store TRU waste from ongoing operations (TA-54-48 and TA-54-153), as well as the four TWISP storage domes (TA-54-229 through TA-54-232). Because TA-54-283 is a temporary structure, essentially there are two single dome targets (TA-54-48 and TA-54-153) and the four-dome target (TA-54-229 through TA-54-232). The single dome targets will represent a small fraction of the total effective aircraft target area for TA-54. Accordingly, aircraft crash analytical efforts were focused on the four-dome TWISP storage dome target.

Based on the TWISP SAR, the four TWISP domes were analyzed as one target with dimensions of 414 feet (126 meters) long, 286 feet (87 meters) wide, and 38 feet (12 meters) high. Skid distance is limited due to the Finger Mesa location, but has been established at 50 feet (15 meters) for conservatism. Based on physical inspection, this is reasonable for all directions except north, for which a longer skid distance can be justified. Considering the configuration of the mesa, a 50-foot (15 meter) skid distance is judged to adequately represent the site.

The estimated perforation/fire frequency for the TWISP domes is 4.3×10^{-6} per year. The crash frequency is dominated by single-engine piston aircraft, multiple-engine piston aircraft, and small military aircraft (the air taxi frequency contribution is conservatively binned with small military in this case), representing 98.2 percent of the total perforation/fire frequency.

Expanded Operations, Reduced Operations, and Greener Alternatives Frequency Analysis

Aircraft crash rates in the vicinity of LANL are not significantly associated with the level of activity at LANL. Accordingly, the frequency of aircraft crash does not vary by alternative.

Uncertainties and Sensitivities Affecting the Frequency of RAD-08

There is a large amount of data required to perform the DOE Standard 3014-96 calculations. In addition, the standard itself requires the use of numerous equations that are recognized to be approximations. Perhaps the most important uncertainty is the assumption (embedded in the standard) that a skidding aircraft will impact a facility with the same velocity it had when it began the skid. This results in a conservative impact velocity because no credit is taken for drag, friction, impact with objects between the impact point and the facility, and so on.

Another conservatism for the TA-54 Area G analysis is the assumption of a 38-foot (12-meter) height for the target. This is the actual height of the membrane domes, but these structures would not offer much resistance to aircraft. Aircraft could in principle strike the dome itself and pass through without impacting the TRU waste stored inside (at least this would be possible with aircraft approaching from the east or west).

As a sensitivity calculation, the height was lowered to 12 feet (4 meters), representing two drum heights. The resulting frequency of perforation/fire crashes was 2.8×10^{-6} per year. The overall reduction in impact frequency for modeling the domes as 12 feet (4 meters) high instead of 38 feet (12 meters) high is less than a factor of two. It is concluded that the impact frequency results are not strongly sensitive to this parameter.

Source Term Calculations

Fires were evaluated for their source term contribution. Three aircraft types account for about 98.2 percent of the total aircraft crash frequency at the TWISP storage domes: (1) single-engine piston aircraft; (2) multiple-engine piston aircraft; and (3) small military aircraft. In order to evaluate the fire and explosion potential of these aircraft, the characteristics of the aircraft in these classes as identified in the supporting documentation for DOE Standard 3014-96 were used to select the bounding fuel load (LLNL 1996). The aircraft selected for these classes are: (1) the Piper Turbo line, with a fuel load of 128 gallons (486 liters), for the single-engine piston aircraft; (2) the Cessna Titan line, with a fuel load of 413 gallons (1,564 liters), for the multiple-engine piston aircraft; and (3) the F-16C, with a fuel load of 1,801 gallons (6,819 liters) for the small military aircraft (LLNL 1996). (The F-16 is typical of local military operations out of Kirtland Air Force Base in Albuquerque, for example.)

In order to quantify the burn area resulting from a spill of aircraft fuel and its subsequent combustion, guidance from the Rocky Flats Risk Assessment Guide was followed that provides an estimate of a 250 square-foot (23 square-meter) burn area per 50 gallons (189 liters) of fuel burned (RFETS 1994). Burn areas were calculated as follows for the three significant classes of aircraft:

$$A_{\text{BURN}} = (F_{\text{LOAD}}/50) \times 250 \text{ ft}^2$$

where:

A_{BURN} = Burn area in square feet

F_{LOAD} = Aircraft fuel load in gallons

The estimated burn area for each of the three significant aircraft types can now be calculated:

Single-Engine Piston Aircraft:

$$A_{\text{BURN}} = (F_{\text{LOAD}}/50) \times 250 \text{ ft}^2$$

$$A_{\text{BURN}} = (128/50) \times 250 \text{ ft}^2$$

$$A_{\text{BURN}} = 640 \text{ ft}^2$$

Multiple-Engine Piston Aircraft:

$$A_{\text{BURN}} = (F_{\text{LOAD}}/50) \times 250 \text{ ft}^2$$

$$A_{\text{BURN}} = (413/50) \times 250 \text{ ft}^2$$

$$A_{\text{BURN}} = 2,065 \text{ ft}^2$$

Small Military Aircraft:

$$A_{\text{BURN}} = (F_{\text{LOAD}}/50) \times 250 \text{ ft}^2$$

$$A_{\text{BURN}} = (1801/50) \times 250 \text{ ft}^2$$

$$A_{\text{BURN}} = 9,005 \text{ ft}^2$$

The area of one of the TWISP storage domes is 16,000 square feet (1,486 square meters). The burn areas identified above represent the following percentages of a single storage dome:

- Single-Engine Piston Aircraft = 4.0 percent
- Multiple-Engine Piston Aircraft = 12.9 percent
- Small Military Aircraft = 56.3 percent

As discussed above, each of the four TWISP storage domes is assumed to contain 4,041 PE-Ci of plutonium-239 as combustible TRU waste and 7,854 PE-Ci of noncombustible TRU waste. The source term contribution will be assumed to be “smeared” evenly across the floor area of the dome (16,000 square feet [1,486 square meters]); calculations will have to be performed separately for combustible and noncombustible fractions because the ARF and RF values are very different.

The DOE Handbook 3010-94 initial source term equation is used, and must be quantified separately for each type of aircraft contributing

significantly to the crash frequency due to the difference in the impacted area of the facility; it is also quantified separately for combustible and noncombustible waste forms. Due to the random nature of aircraft crashes, no specific directionality is associated with the crashes. The damage ratio will be expressed as the percentage of the facility floor area burned in a fire (which will be assumed to equate to the fraction of the inventory affected by fire).

It is recognized that some crashes could result in a fire without affecting MAR; whereas, other crashes could burn a quantity of waste that is in excess of the fraction the floor area affected by the burn. However, the approach adopted above is believed to yield a reasonable result that is considered to be representative of the average that would result from a large number of crashes.

The ARF and RF values are selected from DOE Handbook 3010-94 and are based on the bounding values for packaged mixed waste. The recommended ARF and RF values for combustible waste are 0.0005 and 1.0 (DOE 1994d). The recommended ARF and RF values for noncombustible waste are 0.006 and 0.01 (DOE 1994d). The LPF is taken to be 1 because the TRU waste fabric domes do not represent a confinement structure and because the fabric membranes are assumed to be penetrated by aircraft or aircraft missiles, or breached due to extreme fire conditions.

The general initial source term equation is quantified below for the three aircraft types that contribute to the crash frequency:

Single-Engine Piston Aircraft:

$$\begin{aligned} \text{Initial Combustible Source Term} &= \text{MAR} \times \text{DR} \\ &\times \text{ARF} \times \text{RF} \times \text{LPF} \\ &= 4,041 \times 0.04 \times 0.0005 \times 1 \times 1 \\ &= 0.08\text{E-Ci} \end{aligned}$$

$$\begin{aligned} \text{Initial Noncombustible Source Term} &= \text{MAR} \times \\ &\text{DR} \times \text{ARF} \times \text{RF} \times \text{LPF} \\ &= 7,854 \times 0.04 \times 0.006 \times 0.01 \times 1 \\ &= 0.02 \text{ PE-Ci} \end{aligned}$$

$$\text{Total Initial Source Term} = 0.08 + 0.02 = 0.10 \text{ PE-Ci}$$

Multiple-Engine Piston Aircraft:

$$\begin{aligned} \text{Initial Combustible Source Term} &= \text{MAR} \times \text{DR} \\ &\times \text{ARF} \times \text{RF} \times \text{LPF} \\ &= 4,041 \times 0.129 \times 0.0005 \times 1 \times 1 \\ &= 0.26 \text{ PE-Ci} \end{aligned}$$

$$\begin{aligned} \text{Initial Noncombustible Source Term} &= \text{MAR} \times \\ &\text{DR} \times \text{ARF} \times \text{RF} \times \text{LPF} \\ &= 7,854 \times 0.129 \times 0.006 \times 0.01 \times 1 \\ &= 0.06 \text{ PE-Ci} \end{aligned}$$

$$\text{Total Initial Source Term} = 0.26 + 0.06 = 0.32 \text{ PE-Ci}$$

Small Military Aircraft:

$$\begin{aligned} \text{Initial Combustible Source Term} &= \text{MAR} \times \text{DR} \\ &\times \text{ARF} \times \text{RF} \times \text{LPF} \\ &= 4,041 \times 0.563 \times 0.0005 \times 1 \times 1 \\ &= 1.14 \text{ PE-Ci} \end{aligned}$$

$$\begin{aligned} \text{Initial Noncombustible Source Term} &= \text{MAR} \times \\ &\text{DR} \times \text{ARF} \times \text{RF} \times \text{LPF} \\ &= 7,854 \times 0.563 \times 0.006 \times 0.01 \times 1 \\ &= 0.27 \text{ PE-Ci} \end{aligned}$$

$$\text{Total Initial Source Term} = 1.14 + 0.27 = 1.41 \text{ PE-Ci}$$

Following the initial source term release, resuspension releases are possible due to dispersal of material by the wind. For an aircraft crash, a 24-hour suspension release is considered to be reasonable due to the significant damage resulting from the aircraft crash and subsequent explosion and fire. The general suspension source term equation is used to calculate the suspension source term. The DR is defined in the same manner as with the initial source term. The ARF and RF values are selected from DOE Handbook 3010-94 and are based on the bounding values for packaged mixed waste. The recommended ARR and RF values are 4×10^{-5} per hour and 1.0 (DOE 1994d). Due to the penetration of the building by the aircraft-related missiles and/or due to external or internal explosion of fuel, the LPF is taken to be 1.0. This is assumed to be applicable because it is considered unlikely that a temporary structure would be erected as soon as 24 hours to mitigate releases.

The suspension source term equation also must be quantified individually for each of the three crash frequency contributors (quantification is based on the total PE-Ci content because the ARR and RF values are the same regardless of whether the source MAR is combustible or not):

Single-Engine Piston Aircraft:

$$\begin{aligned} \text{Suspension Source Term} &= \text{MAR} \times \text{DR} \times \text{ARR/hr} \times 24 \text{ hrs} \times \text{RF} \times \text{LPF} \\ &= 11,895 \times 0.04 \times 0.00004 \times 24 \times 1 \times 1 \\ &= 0.46 \text{ PE-Ci} \end{aligned}$$

Multiple-Engine Piston Aircraft:

$$\begin{aligned} \text{Suspension Source Term} &= \text{MAR} \times \text{DR} \times \text{ARR/hr} \times 24 \text{ hrs} \times \text{RF} \times \text{LPF} \\ &= 11,895 \times 0.129 \times 0.00004 \times 24 \times 1 \times 1 \\ &= 1.47 \text{ PE-Ci} \end{aligned}$$

Small Military Aircraft:

$$\begin{aligned} \text{Suspension Source Term} &= \text{MAR} \times \text{DR} \times \text{ARR/hr} \times 24 \text{ hrs} \times \text{RF} \times \text{LPF} \\ &= 11,895 \times 0.563 \times 0.00004 \times 24 \times 1 \times 1 \\ &= 6.43 \text{ PE-Ci} \end{aligned}$$

In order to specify a single source term for the TA-54 Area G aircraft crash accident, the initial source terms and suspension source terms are frequency-weighted below according to their contributions to the overall risk, as shown in Tables G.5.6.8-2 and G.5.6.8-3.

TABLE G.5.6.8-2.—Frequency Weighted Source Term Calculation for Initial Source Term

AIRCRAFT TYPE	PERCENTAGE CONTRIBUTION TO AIRCRAFT CRASH FREQUENCY	INITIAL SOURCE TERM (PLUTONIUM-239 PE-Ci)	WEIGHTED INITIAL SOURCE TERM (PLUTONIUM-239 PE-Ci)
Single-Engine Piston	0.884	0.10	0.088
Multiple-Engine Piston	0.060	0.32	0.019
Small Military	0.037	1.41	0.052
TOTAL	0.981		0.16

TABLE G.5.6.8-3.—Frequency Weighted Source Term Calculation for Suspension Source Term

AIRCRAFT TYPE	PERCENTAGE CONTRIBUTION TO AIRCRAFT CRASH FREQUENCY	SUSPENSION SOURCE TERM (PLUTONIUM-239 PE-Ci)	WEIGHTED SUSPENSION SOURCE TERM (PLUTONIUM-239 PE-Ci)
Single-Engine Piston	0.884	0.46	0.41
Multiple-Engine Piston	0.060	1.47	0.09
Small Military	0.037	6.43	0.24
TOTAL	0.981		0.74

Based on these calculations the source term for RAD-08 for the No Action Alternative will be represented with an initial source term of 0.16 PE-Ci released in 30 minutes, and a suspension source term of 0.74 PE-Ci released over 24 hours. There are no differences in source term across the alternatives (because the No Action Alternative source terms are based on the average maximum quantity of TRU waste in the four TWISP storage domes). The TWISP source term is identical across the alternatives.

Uncertainties and Sensitivities Affecting the Source Term for RAD-08

The source terms (initial and suspension) are the average maximum values expected for the TWISP storage domes once they are fully loaded. Of course, it is possible that an aircraft crash would occur in a dome that is not fully loaded (or even empty, depending on timing). Clearly, the values calculated above are bounding, assuming the average maximum quantities are correct.

The number of TWISP storage domes occupied with TRU waste will depend on the processing rate during TWISP recovery and repackaging and also on the WIPP shipment rate. Neither of these rates is known with precision, particularly the latter. Thus, a bounding calculation was performed.

The suspension source term calculation extends for 24 hours. This may be very conservative in that it is likely that fire fighting and HAZMAT response to the crash scene would be accompanied by extensive use of water and foam-based suppression systems. This application of suppressants would likely continue for some time to preclude flareup of the fire once it is extinguished, as well as to limit further spread of plutonium contamination.

Consequences of RAD-08 for Facility Workers and the Public

The consequences of RAD-08 for facility workers and the public are discussed separately. Typically, only a small number of facility workers would be expected to be present at the TWISP domes, and would be at risk for possible exposure to airborne radioactive material as well as exposure to the dynamics of the aircraft crash. An aircraft crash into the dome that destroys part of the facility is assumed to result in the death of all workers in the part that is destroyed. Workers elsewhere in the structure may be injured or killed due to flying debris or secondary effects from the fire (e.g., smoke inhalation). Workers in the dome who are not directly affected by the crash and explosion or fire may be exposed to radiation as a result of plutonium inhalation. If the dome collapses as a result of the impact of the aircraft (which is to be expected), additional injuries or fatalities could result.

No acute fatalities are predicted to result from the postulated accident. The mean collective population dose is projected to total 400 person-rem (TEDE), resulting in 0.2 excess LCFs. Mean projected doses for MEIs (and their associated locations) and ground contamination levels are presented in Tables G.5.6.8–5 and G.5.6.8–6, respectively. Table G.5.6.8–4 summarizes the modeling results for RAD–08.

G.5.6.9 ***RAD–09, Plutonium Release from TRU Waste Drum Failure or Puncture***

General Scenario Description

A contact-handled TRU waste drum failure/puncture is postulated to occur during drum handling operations (all subsequent discussions refer to the waste as TRU waste). Either a complete or a partial drum spill may occur. A complete spill of drum contents is more likely to occur during retrieval of TRU waste from Pads 1, 2, and 4 at TA–54, Area G (considering the potential for degraded drums and the number of drums to be retrieved, 16,641). A partial spill of drum contents would result from drum puncture accidents or from the majority of drop related accidents. This scenario assumes a complete spill occurs to represent failure of a degraded drum and to conservatively bound an individual or multiple drum puncture accident. A large majority of drum handling operations occur outdoors or within structures that do not have HEPA filtration. Consequently, the accident scenario postulates that the incident occurs outdoors. The drum failure/puncture scenario could occur at multiple facilities at TA–3, TA–16, TA–50, TA–54, or TA–55. The accident is postulated to occur at TA–54, Area G because the large majority of TRU waste drum handlings occur there.

Drum handling operations are primarily conducted with forklifts/lift trucks. Exceptions include the use of drum dollies for movements within facilities or dock areas, drum lift fixtures

for glovebox entry/egress, manual methods (such as individual drum retrieval activities at Pads 1, 2, and 4), and crane/hoist activities (such as WCRR Facility enclosure movements or RANT transportation bay loading activities). Drum handling may be conducted on an individual drum basis, on a palletized basis (four drums banded together), or on a 7-pack basis (seven drums banded together by metal banding or plastic stretch wrap for shipment to WIPP in a TRUPACT-II container). Drum drop tests at Hanford (WHC 1995) have demonstrated that dropping a pallet of four banded drums results in damage to a single drum. Consequently, the MAR (one drum) for this postulated accident scenario would be representative of an accident involving the handling of multiple drums.

Because waste management activities involve the movement of a large number of TRU waste containers, with the large majority having a low radioactive material content, risks associated with a drum failure/puncture will be evaluated for both an average and a high radioactive content drum.

Note that this accident scenario does not include TRU waste drum handling operations associated with possible retrieval of buried TRU waste located on Pads 9 and 29 and in Trenches A, B, C, and D. Possible retrieval of this waste was mentioned briefly as being conducted during the 10-year period covered by the SWEIS in the draft November 1996 Waste Management Strategies document issued by LANL (LANL 1996o), but insufficient specific information was available upon which to base a quantification of possible impacts.

A similar accident scenario is analyzed in the Safety Analysis Report for TA–54, Area G (LANL 1995f), with the exception that it assumes that intact drums are involved in the accident. The postulated accident scenario evaluated for the SWEIS is intended to cover potential accidents involving retrieval of degraded drums from earthen-covered storage

TABLE G.5.6.8-4.—Summary of Results for Scenario RAD-08

ALTERNATIVE	ACCIDENT FREQUENCY	SOURCE TERM AND CONSEQUENCES
No Action	4.3×10^{-6}	Initial source term of 0.16 PE-Ci released in 30 minutes; suspension source term of 0.74 PE-Ci, released over 24 hours; integrated population exposure of 400 person-rem, 0.2 excess LCFs.
Expanded Operations	4.3×10^{-6}	Same as No Action Alternative.
Reduced Operations	4.3×10^{-6}	Same as No Action Alternative.
Greener	4.3×10^{-6}	Same as No Action Alternative.

TABLE G.5.6.8-5.—Predicted Mean Doses to MEIs for Scenario RAD-08

MAXIMUM EXPOSED INDIVIDUAL (MEI) DOSE (REM, TEDE)	
MEI LOCATION	DOSE
Closest public access from TA-54-229: Pajarito Road (210 m) ^a	2.2×10^1
Closest site boundary from Pads 1, 2 and 3 White Rock (245 m) (see note) (TWISP SAR; TA-54 Area G SAR)	2.2×10^1
Special population distance from TA-54-229: San Ildefonso boundary (500 m)	7.2×10^0
Closest White Rock residence from TA-54-229 (1,500 m)	1.1×10^0
Closest population center from Pads 1, 2 and 3: White Rock (1,680 m) (TWISP SAR; TA-54 Area G SAR)	9.6×10^{-1}
Special population distance from TA-54-229: Piñon Elementary School/Park (2100 m)	6.6×10^{-1}
Special population distance from TA-54-229: San Ildefonso Pueblo (14,300 m)	2.5×10^{-2}

^a Estimated using radial distance of 230 m.

TABLE G.5.6.8-6.—Predicted Mean Ground Contamination Levels for Scenario RAD-08

RADIAL DISTANCE	PLUTONIUM-239 GROUND CONCENTRATION (BQ/m ²)
0.0 to 1.0 km	3.9 x 10 ⁴
1.0 to 2.0 km	5.1 x 10 ³
2.0 to 3.0 km	2.1 x 10 ³
3.0 to 4.0 km	1.2 x 10 ³
4.0 to 8.0 km	4.8 x 10 ²
8.0 to 12.0 km	1.9 x 10 ²
12.0 to 20.0 km	6.6 x 10 ¹
20.0 to 30.0 km	2.8 x 10 ¹
30.0 to 40.0 km	1.5 x 10 ¹
40.0 to 60.0 km	7.2 x 10 ⁰
60.0 to 80.0 km	3.5 x 10 ⁰

BQ/m² = Becquerel per square meter

at Pads 1, 2, and 4. The SAR accident scenario results from forklift handling of a waste container. The accident frequency in the SAR is based on 5,000 waste container handling events per year at Area G, a waste handling accident frequency of 1×10^{-5} per container handling event, and a conditional probability of 1×10^{-2} of involving a maximum drum (1,000 PE-Ci). (The WIPP WAC previously allowed up to 1,000 PE-Ci per waste container.)

Selected parameter values that were used for this source term analysis were: (1) MAR—bounding value of 1,000 PE-Ci (previous WIPP WAC limit); (2) damage ratio—0.1, based on engineering judgement and cited drum drop test results for DOT Type A containers; (3) airborne release fraction—0.0001, bounding value for solid contaminated material from an early draft of DOE Handbook 3010-94; (4) respirable fraction—0.05, based on a draft of DOE Handbook 3010-94; and (5) leakpath factor—1.0 (bounding).

The Final Safety Analysis Report (FSAR) for the Retrieval for Transuranic Waste from Pads 1, 2, and 4 at TA-54, Area G evaluates a degraded TRU waste container failure during retrieval (LANL 1996n) in support of the TWISP. While all waste containers are examined for signs of degradation and are stabilized as necessary before retrieval, it is assumed that the bottom of a degraded waste drum could fail. The FSAR retrieval accident scenario frequency is based on 20,000 waste handling events per year, a waste handling accident frequency of 1×10^{-5} per container handling event, and a conditional probability of 1×10^{-2} of involving a drum with greater than 100 PE-Ci. For this analysis the source term was based on: (1) the current maximum TRU waste container of 658 PE-Ci (LANL 1996n); (2) a damage ratio of 0.5, based on engineering judgement for a degraded drum and cited drum drop tests; (3) an airborne release fraction of 0.001; (4) a respirable fraction of 0.1; and (5) a leakpath factor of 1.0.

The SAR for the WCRR Facility analyzes a postulated waste drum puncture accident in the outdoor staging area (LANL 1995e). It is assumed that a forklift tine punctures a waste drum being loaded on or off the bed of a truck. Because a drum grapple will be used to handle drums at all times when the drums are not palletized, the SAR concludes a scenario of this type is not credible for other drum handling operations. The SAR puncture accident scenario frequency is based on 200 movements of palletized drums per year and a waste handling accident frequency of 1×10^{-5} per container handling event. The source term was based on: (1) the proposed WCRR Facility limits for plutonium mixes or individual radionuclides (DOE Standard 1027-92 Hazard Category 3 threshold limits, WIPP WAC fissile gram equivalent limit of 325 grams), (2) a damage ratio of 0.05 (puncture of a nondegraded drum), (3) an airborne release fraction of 0.001, (4) a respirable fraction of 0.05, and (5) a leakpath factor of 1.0.

The SAR for the Radioactive Materials Research, Operations, and Demonstration Facility evaluates a postulated accident involving a forklift dropping a single TRU waste container (outside) from greater than four feet (which is the qualification limit for DOT Type A containers) (LANL 1996i). The SAR drum drop accident scenario frequency is based on 5,000 waste movements per year, a waste handling accident frequency of 1×10^{-5} per movement, and a conditional probability of 1×10^{-1} of involving a maximally loaded drum (1,000 PE-Ci). The source term was based on: (1) the previous WIPP WAC container limit of 1,000 PE-Ci, (2) a damage ratio of 0.1 (drop of a nondegraded drum), (3) an airborne release fraction of 0.001, (4) a respirable fraction of 0.05, and (5) a leakpath factor of 1.0.

The SA for the NDA/NDE Facility analyzes a design basis accident involving the puncture of a TRU waste drum by a forklift tine (LANL 1996j). A supplemental analysis is presented in the SA appendix for a smaller breach due to a drum grapppler accident. The postulated accident frequency is based on a throughput of 5,000 drums per year (interim operation limit) and a forklift tine or grapppler puncture conditional frequency of 1×10^{-5} or 1×10^{-6} per movement, respectively. The source term was based on the maximum radionuclide inventory for a drum (200 grams of plutonium-239, or 40 grams of plutonium-238, or 19 grams of americium-241).

No Action Alternative Frequency Analysis

Legacy waste (current dome storage) requiring characterization is estimated to involve six forklift handling operations: (1) loading onto a truck for transfer to an on-site location for assay verification, (2) unloading of the transfer truck for assay verification, (3) waste drum loading onto a transfer truck for movement to interim storage (Area G), (4) unloading of the transfer truck for interim storage, (5) waste drum movement to a staging area for shipment to

WIPP, and (6) waste drum movement for loading a TRUPACT-II for shipment to WIPP.

Legacy waste (earthen-covered storage) requiring characterization/treatment is estimated to involve seven forklift handling operations: (1) retrieval of drum to laydown area, (2) drum movement for gas venting, (3) loading onto a truck for transfer to an on-site treatment location (such as the drum preparation facility), (4) unloading of the transfer truck for waste treatment, (5) waste drum movement for final NDA/NDE, (6) waste drum loading and unloading for interim storage (dome), and (7) waste drum loading and unloading of a transfer truck and subsequent movement for loading a TRUPACT-II for shipment to WIPP.

Legacy waste (earthen-covered storage) requiring overpacking/repackaging is estimated to require the same number of forklift handling operations as legacy waste that requires characterization.

The pre-decisional draft of the SWEIS Alternatives Document, Waste Management Key Facility (LANL 1997c), indicates that the newly generated waste volume for the No Action Alternative over the ten-year SWEIS time frame will total an estimated 6.61×10^5 gallons (2,500 cubic meters). This is equivalent to 12,018, 55-gallon drums. The entire legacy waste (dome and earthen covered) volume of approximately 2.38×10^6 gallons (9,000 cubic meters) is assumed shipped to WIPP during the SWEIS period. The legacy waste volume is equivalent to 43,273, 55-gallon drums, of which 21,136, 55-gallon drums (4,400 cubic meters) are in earthen covered storage (LANL 1997c).

It is estimated that there will be approximately 8,413 ($12,018 \times 7/10$) waste drum handlings per year for newly generated TRU waste. Similarly, for dome legacy waste, it is estimated that there will be approximately 11,069 ($[43,273 - 21,136] \times 5/10$) waste drum handlings per year. Earthen-covered legacy waste movements are estimated to total 21,137 ($21,137 \times 10/10$) per

year. Thus, the No Action Alternative is estimated to total 40,619 TRU waste handling (forklift) events per year. This is consistent with the 30,000-plus waste handling events identified in the cited LANL safety documentation.

Based on DOE system operating experience, the waste handling accident frequency is estimated as 1×10^{-5} per container handling event. This conditional accident frequency is cited in multiple LANL safety documents, including the TA-54 TWISP FSAR (LANL 1996n), the TA-54 Area G SAR (LANL 1995f), and the WCRR Facility FSAR (LANL 1995e). Additionally, the TA-54 Area G SAR indicates that less than 1 percent of all TRU waste containers in the existing Area G inventory exceed 75 PE-Ci in radioactive material content (LANL 1995f). Thus, it can be concluded that the conditional probability of a handling accident involving a high radioactive content drum is less than 1 percent. With the foregoing information, the frequency of a drum failure/puncture due to a forklift accident can be calculated as:

$$F_{\text{FAILURE}} = N_{\text{FEVENTS}} \times C_{\text{PFACC}} \times C_{\text{PHI/AVG}}$$

where:

N_{FEVENTS} = Number of forklift handling events per year

C_{PFACC} = Conditional probability of a forklift accident resulting in a container failure

$C_{\text{PHI/AVG}}$ = Conditional probability of accident involving an average or high radioactive content container

Substituting the above values, the annual frequency for a drum failure/puncture at LANL is:

High Radioactive Content Container:

$$F_{\text{FAILURE}} = N_{\text{FEVENTS}} \times C_{\text{PFACC}} \times C_{\text{PHI/AVG}}$$

$$F_{\text{FAILURE}} = 40,619 \times (1 \times 10^{-5}) \times 0.01$$

$$F_{\text{FAILURE}} = 0.0041 \text{ per year}$$

Average Radioactive Content Container:

$$F_{\text{FAILURE}} = N_{\text{FEVENTS}} \times C_{\text{PFACC}} \times C_{\text{PHI/AVG}}$$

$$F_{\text{FAILURE}} = 40,619 \times (1 \times 10^{-5}) \times 0.99$$

$$F_{\text{FAILURE}} = 0.4 \text{ per year}$$

Expanded Operations Alternative Frequency Analysis

The pre-decisional draft of the SWEIS Alternatives Document, Waste Management Key Facility (LANL 1997c), indicates that Expanded Operations Alternative waste management practices and the mixed LLW waste generation rate will be comparable to the No Action Alternative. However, newly generated TRU waste volumes are expected to double to 1.35×10^6 gallons (5,100 cubic meters) from those in the No Action Alternative. This is equivalent to 24,545, 55-gallon drums.

It is estimated that there will be approximately 17,182 ($24,545 \times 7/10$) waste drum handlings per year for newly generated TRU waste. TRU waste drum handlings for legacy TRU waste will be the same as the No Action Alternative because waste management practices will be the same for both alternatives. Thus, the Expanded Operations Alternative is projected to total 49,388 ($17,182 + 11,069 + 21,137$) TRU waste handling (forklift) events per year.

With a revised number of TRU waste handling events for the Expanded Operations Alternative, the frequency (F_{FAILURE}) of a postulated drum failure/puncture can be estimated as:

High Radioactive Content Container:

$$F_{\text{FAILURE}} = N_{\text{FEVENTS}} \times C_{\text{PFACC}} \times C_{\text{PHI/AVG}}$$

$$F_{\text{FAILURE}} = 49,388 \times (1 \times 10^{-5}) \times 0.01$$

$$F_{\text{FAILURE}} = 0.0049 \text{ per year}$$

Average Radioactive Content Container:

$$F_{\text{FAILURE}} = N_{\text{EVENTS}} \times C_{\text{PFACC}} \times C_{\text{PHI/AVG}}$$

$$F_{\text{FAILURE}} = 49,388 \times (1 \times 10^{-5}) \times 0.99$$

$$F_{\text{FAILURE}} = 0.49 \text{ per year}$$

Reduced Operations Alternative Frequency Analysis

The pre-decisional draft of the SWEIS Alternatives Document, Waste Management Key Facility (LANL 1997c), indicates that Reduced Operations Alternative waste management practices and the mixed LLW waste generation rate will be comparable to the No Action Alternative. However, TRU waste volumes are expected to total 5.02×10^5 gallons (1,900 cubic meters), almost 25 percent less than those for the No Action Alternative. This is equivalent to 9,127, 55-gallon drums.

It is estimated that there will be approximately 6,389 ($9,127 \times 7/10$) waste drum handlings per year for newly generated TRU waste. TRU waste drum handlings for legacy TRU waste will be the same as the No Action Alternative because waste management practices will be the same for both alternatives. Thus, the Reduced Operations Alternative is projected to total 38,595 ($6,389 + 11,069 + 21,137$) TRU waste handling (forklift) events per year.

With a revised number of TRU waste handling events for the Expanded Operations Alternative, the frequency (F_{FAILURE}) of a postulated drum failure/puncture can be estimated as:

High Radioactive Content Container:

$$F_{\text{FAILURE}} = N_{\text{EVENTS}} \times C_{\text{PFACC}} \times C_{\text{PHI/AVG}}$$

$$F_{\text{FAILURE}} = 38,595 \times (1 \times 10^{-5}) \times 0.01$$

$$F_{\text{FAILURE}} = 0.0039 \text{ per year}$$

Average Radioactive Content Container:

$$F_{\text{FAILURE}} = N_{\text{EVENTS}} \times C_{\text{PFACC}} \times C_{\text{PHI/AVG}}$$

$$F_{\text{FAILURE}} = 38,595 \times (1 \times 10^{-5}) \times 0.99$$

$$F_{\text{FAILURE}} = 0.38 \text{ per year}$$

Greener Alternative Frequency Analysis

The pre-decisional draft of the SWEIS Alternatives Document, Waste Management Key Facility (LANL 1997c), indicates that the Greener Alternative waste management practices and waste generation rates for mixed LLW and TRU waste will be comparable to those for the No Action Alternative. On this basis, it is expected that TRU waste handling and the associated frequency of a potential container failure will be the same as in the No Action Alternative.

Uncertainties and Sensitivities Affecting the Frequency of RAD-09

Uncertainties include broad characterization of drum handling events by waste category type, the extent that particular drum movements involve multiple drums (thus reducing the number of drum handlings), and the likelihood that all legacy TRU waste is shipped to WIPP (and the associated handlings at LANL) during the LANL SWEIS time frame. Drum movement characterization assumptions were chosen to provide an upper estimate of the frequency of occurrence for the postulated accident and are reasonably conservative when compared with the number of drum movements identified in LANL safety documentation.

Source Term Calculations

Currently, the average TRU radioactive material content per waste container is 8.9 PE-Ci (LANL 1995f). Revision 5 of the WIPP WAC limits the maximum plutonium-239 equivalent activity for untreated CH-TRU waste to be received by the facility to 80 PE-Ci per drum, if not overpacked. The WIPP WAC

previously allowed up to 1,000 PE-Ci per waste container. Based on the existing inventory, the maximum container of TRU waste has 658 PE-Ci of radioactive material (LANL 1996n).

Source Term for High Radioactive Content Container. The source term for a postulated accident involving a high radioactive content TRU container is based on the identified maximum drum of TRU waste (658 PE-Ci) to be managed at LANL. From the above discussion, it is clear that this will provide a bounding source term value. As noted in section 3, the frequency of occurrence calculation accounts for the likelihood (or lack thereof) that the postulated accident would involve a drum with a high radioactive material content. (Note that RAD-07 was a fire involving 62 drums, with their expected PE-Ci content; whereas, this accident involves a single drum of the maximum PE-Ci content.)

A damage ratio of 1.0 is conservatively assumed for the postulated accident to account for a degraded drum failure during retrieval handling activities. The TWISP SAR (LANL 1996n) accounted for the potential of a degraded drum, but interpreted drum drop tests for nondegraded drums on an unyielding surface to justify a somewhat less conservative value for the damage ratio (0.5). Bounding values for the airborne release fraction and respirable release fraction of 0.001 and 0.1, respectively, are assigned and are representative of the situation where surface contaminated material is packaged in a robust container (e.g., drum) that fails due to impact with the floor. The accident is assumed to occur outdoors such that the leakpath factor has a value of 1.0. With the above information, the initial source term equation can be quantified as follows:

$$\text{Initial Source Term} = \text{MAR} \times \text{DR} \times \text{ARF} \times \text{RF} \times \text{LPF}$$

$$= 658 \text{ PE-Ci} \times 1.0 \times 0.001 \times 0.1 \times 1.0$$

$$= 0.066 \text{ PE-Ci}$$

The suspension MAR equals the initial MAR, minus the initial source term (0.066), which for this case effectively equals the initial MAR. The suspension DR and LPF have the same values (1.0) as in the initial source term calculation. The ARR and RF are assigned values of 4×10^{-5} and 1.0, respectively, based on bounding resuspension factors for surface contaminated material exposed to ambient conditions (DOE 1994d). Thus, the suspension source term can be quantified as:

$$\text{Suspension Source Term} = \text{MAR} \times \text{DR} \times \text{ARR} \times 24 \text{ hrs} \times \text{RF} \times \text{LPF}$$

$$= 658 \text{ PE-Ci} \times 1.0 \times (4 \times 10^{-5}) \times 24 \text{ hrs} \times 1.0 \times 1.0$$

$$= 0.63 \text{ PE-Ci}$$

It can be seen that the suspension source term is an order of magnitude greater than the initial source term. The calculated suspension source term is highly conservative considering that DOE Handbook 3010-94 assigns the same suspension value for surface contaminated materials as for powders and the assumption that the spill is not controlled for 24 hours. This is conservative since the HAZMAT team would be expected to clean up the spill much sooner than 24 hours.

Source Term Analysis for Average Radioactive Content Container. The source term for this postulated accident is based on a conservative estimate of the average radioactive content (12 PE-Ci) of a TRU waste container, as noted above. Other initial source term parameters for the high radioactive content container would be applicable and are retained for the analysis of an average radioactive content container. Thus, the initial source term is quantified as:

$$\begin{aligned} \text{Initial Source Term} &= \text{MAR} \times \text{DR} \times \text{ARF} \times \text{RF} \\ &\quad \times \text{LPF} \\ &= 12 \text{ PE-Ci} \times 1.0 \times 0.001 \times 0.1 \times 1.0 \\ &= 0.0012 \text{ PE-Ci} \end{aligned}$$

The suspension MAR equals the initial MAR, minus the initial source term (0.0012), which for this case effectively equals the initial MAR. The suspension DR and LPF have the same values (1.0) as in the initial source term calculation. The ARR and RF are assigned values of 4×10^{-5} and 1.0, respectively, based on bounding resuspension factors for surface contaminated material exposed to ambient conditions (DOE 1994d). Thus, the suspension source term can be quantified as:

$$\begin{aligned} \text{Suspension Source Term} &= \text{MAR} \times \text{DR} \times \text{ARR} \\ &\quad \times 24 \text{ hrs} \times \text{RF} \times \text{LPF} \\ &= 12 \text{ PE-Ci} \times 1.0 \times (4 \times 10^{-5}) \times 24 \text{ hrs} \times 1.0 \times 1.0 \\ &= 0.0115 \text{ PE-Ci} \end{aligned}$$

As with the high radioactive content container analysis, it can be seen that the suspension source term is an order of magnitude greater than the initial source term and is conservative.

Because the source terms are based on average and maximum content containers, there are no variations across the alternatives.

| Uncertainties and Sensitivities for RAD-09

This accident assumes that all of the material in a drum is spilled. This assumption is very conservative because a drum puncture due to a drop or a puncture with a forklift is not likely to spill the entire contents of a TRU waste container. The conservative assumption, however, would bound this instance or the consequences of an event where more than one drum would be punctured. The ARF, ARR, and RF values also bound the type of material that could be involved in the accident. Thus, the accident represents a bound on the variations

that could occur with a drum puncture and is still considered conservative.

The suspension term is the dominate contributor to the doses for this event. Because of the nature of the drum puncture event, the cleanup can be easily controlled and evaluated. If cleanup is assumed to take 1-hour as opposed to 24 hours, the suspension terms would then change as shown in Table G.5.6.9-1.

If the results are scaled by the source and suspension terms consistent with a 1-hour cleanup period, the consequences would be as given in Table G.5.6.9-2.

The results for the 24-hour cleanup are very conservative. Because of the limited nature of the accident, the expectation is for cleanup to

TABLE G.5.6.9-1.—Suspension Terms for RAD-09

SCENARIO	SUSPENSION TERM 1-HOUR CLEANUP	SUSPENSION TERM 24-HOUR CLEANUP
Average Activity Container	0.00048 PE-Ci	0.012 PE-Ci
High Activity Container	0.026 PE-Ci	0.63 PE-Ci

TABLE G.5.6.9-2.—Consequences for RAD-09, 1-Hour Cleanup

SCENARIO	INTEGRATED POPULATION DOSE (PERSON-REM, TEDE)	EXCESS LCFS
Average Activity Container	0.55	2.7×10^{-4}
High Activity Container	30	0.015

begin immediately after the accident and to be completed within 1 hour.

Consequences of RAD-09 for Facility Workers and the Public

The consequences for facility workers and the public are discussed separately. All facility operations personnel receive emergency preparedness training specific to the facility and for procedures applicable to all of LANL. The Emergency Action Plan directs personnel to move as quickly as possible in an upwind direction away from any hazardous situation and to make appropriate notifications to the Emergency Management and Response (EM&R) Group Office as soon as they are safely away from the hazard. Once notified, the EM&R Office assumes all elements of emergency response and coordination.

The postulated accident would result in an immediate release to the surrounding area. The primary hazard would be airborne suspension of respirable radioactive material. The dose to the involved worker would be dependent on the ambient conditions of the accident and how they affect dilution of the radioactive material in the

air (e.g., outdoors, wind speed, confined area, indoors or outdoors), the time for the worker to identify a release and to vacate the immediate area, and any impediments (accident related) to the worker's movement away from the release. The number of workers potentially exposed would depend on the location of the accident and the nature of the activity being conducted at the time of the accident (e.g., retrieval versus waste staging versus truck loading/unloading).

No acute fatalities are predicted to result from a postulated accident involving an average or a high radioactive content drum. The mean collective population dose is projected to total 4.4 person-rem (TEDE) for an accident involving an average radioactive content drum, resulting in 0.0022 excess LCF. For a high radioactive content drum, accident impacts are projected to total 230 person-rem (TEDE), resulting in 0.12 excess LCF. Mean projected doses for MEIs (and their associated locations) and ground contamination levels are presented in Tables G.5.6.9-4 and G.5.6.9-5, respectively. Table G.5.6.9-3 summarizes the modeling results for RAD-09.

TABLE G.5.6.9-3.—Summary Results for Scenario RAD-09

ALTERNATIVE	ACCIDENT FREQUENCY	SOURCE TERM AND CONSEQUENCES
No Action	0.0041 per year (High Activity)	High Activity Container: Initial source term is 0.066 plutonium-239 PE-Ci, ground-level release; suspension source term is 0.63 plutonium-239 PE-Ci, ground-level release; integrated population exposure of 230 person-rem (TEDE), 0.12 excess LCF.
	0.4 per year (Avg. Activity)	Average Activity Container: Initial source term is 0.0012 plutonium-239 PE-Ci, ground-level release; suspension source term is 0.012 plutonium-239 PE-Ci, ground-level release; integrated population exposure of 4.4 person-rem, 0.0022 excess LCF.
Expanded Operations	0.0049 per year (High Activity)	Same as No Action Alternative.
	0.49 per year (Avg. Activity)	
Reduced Operations	0.0039 per year (High Activity)	Same as No Action Alternative.
	0.38 per year (Avg. Activity)	
Greener	0.0041 per year (High Activity)	Same as No Action Alternative.
	0.4 per year (Avg. Activity)	

TABLE G.5.6.9-4.—Predicted Mean Doses to MEIs for Scenario RAD-09

MAXIMUM EXPOSED INDIVIDUAL (MEI) DOSE (REM, TEDE)		
MEI LOCATION	AVERAGE RAD CONTENT DRUM	HIGH RAD CONTENT DRUM
Closest public access from TA-54-229: Pajarito Road (210 m) ^a	4.1×10^{-1}	2.3×10^1
Closest site boundary from Pads 1, 2 and 3: White Rock (245 m) ^a (TWISP SAR; TA-54 Area G SAR)	4.1×10^{-1}	2.3×10^1
Special population distance from TA-54-229: San Ildefonso boundary (500 m)	1.1×10^{-1}	6.1×10^0
Closest White Rock residence from TA-54-229 (1500 m)	1.6×10^{-2}	8.6×10^{-1}
Closest population center from Pads 1, 2 and 3: White Rock (1,680 m) (TWISP SAR; TA-54 Area G SAR)	1.3×10^{-2}	7.0×10^{-1}
Special population distance from TA-54-229: Piñon Elementary School/Park (2,100 m)	8.4×10^{-3}	4.6×10^{-1}
Special population distance from TA-54-229: San Ildefonso Pueblo (14,300 m)	2.2×10^{-4}	1.2×10^{-2}

^a Estimated using radial distance of 230 m.

TABLE G.5.6.9-5.—Predicted Mean Ground Contamination Levels for Scenario RAD-09

RADIAL DISTANCE	PLUTONIUM-239 GROUND CONCENTRATION (BQ/m ²)	
	AVERAGE CONTENT	HIGH CONTENT
0.0 to 1.0 km	6.2×10^2	3.4×10^4
1.0 to 2.0 km	6.1×10^1	3.4×10^3
2.0 to 3.0 km	2.4×10^1	1.3×10^3
3.0 to 4.0 km	1.3×10^1	6.9×10^2
4.0 to 8.0 km	4.7×10^0	2.6×10^2
8.0 to 12.0 km	1.9×10^0	1.0×10^2
12.0 to 20.0 km	7.1×10^{-1}	3.9×10^1
20.0 to 30.0 km	2.8×10^{-1}	1.6×10^1
30.0 to 40.0 km	1.5×10^{-1}	8.3×10^0
40.0 to 60.0 km	7.4×10^{-2}	4.1×10^0
60.0 to 80.0 km	4.4×10^{-2}	2.4×10^0

BQ/m² = Becquerel per square meter

G.5.6.10 *RAD-10, Plutonium Release from Degraded Vault Storage Container at TA-55-4*

General Scenario Description

TA-55-4 is the Plutonium Facility at LANL. Among the activities at TA-55-4 is the storage of a large quantity of plutonium in vault rooms in the basement of the building. Accident scenario RAD-10 involves dropping a plutonium container during retrieval from the vault. The container is a degraded container that fails and disperses plutonium into the atmosphere of the vault. If this sequence of events occurs during normal operations with both the HVAC and HEPA systems in operation, the release will be filtered by several stages of HEPA filters, and the release to the environment will be less than 10^{-8} grams. Under the SWEIS screening criteria, this scenario would screen. In order to have a release to the environment, the HEPA filters would have to be failed or the facility would have to lose power, placing the facility into a breathing mode. The breathing mode results in an LPF of 0.011 (LANL 1996k), while the LPF with the HEPA filters failed and the HVAC system in operation is assumed to be 1.0 (LANL 1996k). The LPF under normal conditions with both HVAC and HEPA filters in operation is 8×10^{-13} for a multi-stage HEPA filter system (LANL 1996k).

As a result of implementation of the Defense Nuclear Facilities Safety Board (DNFSB) Recommendation 94-01 by DOE, LANL will be retrieving from storage, stabilizing, and repackaging a large amount of plutonium (DNFSB 1994). LANL began its program with 8,670 containers of plutonium, and had completed about 17 percent of the program as of early 1996. There are approximately 7,200 remaining containers to be retrieved and repackaged by the year 2002. This represents a

rate of about 1,200 per year over the 6-year period from 1996 to 2002.

LANL has already completed a 100 percent visual inventory inspection of the packages so far retrieved, and found 361 containers with some defect. Of these, 82 appeared to have lost outer containment.

LANL has approached the degraded container issue from a systems reliability standpoint. There is a total of 7,200 plutonium containers remaining in the vault. Of these, 5.5 percent are projected to have a failed outer container (i.e., a total of 396). Of these, an estimated 2 percent also have failed inner containers (i.e., a total of 8) (LANL 1996p). DOE Standard 3013-96 (DOE 1996e) addresses the requirements for containers for long-term (at least 50 years) storage of plutonium. To meet the standard, plutonium-bearing materials must be in stable forms and packaged in containers designed to maintain their integrity under both normal storage conditions and anticipated handling accidents for at least 50 years (DOE 1996e). The standard applies to metal, oxide, and alloys containing at least 50 percent plutonium by mass, and containing less than 3 percent plutonium-238 by mass (DOE 1996e). The quantity of metal per container should be as close as practical to, but not exceed, 9.68 pounds (4.40 kilograms). Stored metal pieces are required to have thicknesses greater than 0.04 inch (1.0 millimeter) and have specific surface areas less than 71 square inches per pound (1.0 square centimeters per gram) to reduce potential pyrophoric tendencies (DOE 1996e). The quantity of oxide by container should be as close as practical to, but not exceed, 10.97 pounds (5.00 kilograms), representing the plutonium dioxide equivalent of 9.68 pounds (4.40 kilograms) of plutonium metal. The oxides are required to be thermally stabilized with less than 0.5 percent mass loss-on-ignition (DOE 1996e). The containers are required to include a minimum of two nested sealed containers and have at least one container that remains leak-tight after a free drop from a

30-foot (9-meter) height into a flat, essentially unyielding, horizontal surface (DOE 1996e). The containers are required to have a cylindrical geometry not exceeding 4.9 inches (12.5 centimeters) outside diameter or 10 inches (25.4 centimeters) external height (DOE 1996e). Once the plutonium is repackaged in DOE Standard 3013-96-compliant containers, the likelihood of RAD-10 will be significantly reduced.

The TA-55 SAR (LANL 1996k) analyzes this scenario in detail. The SAR places the unmitigated scenario (i.e., with HVAC operating and HEPA filters failed) into the frequency bin from 10^{-4} to 10^{-2} per year. The SAR quantified the source term as follows (LANL 1996k):

$$\begin{aligned} & \text{Initial Source Term} \\ & = \text{MAR} \times \text{DR} \times \text{ARF} \times \text{RF} \times \text{LPF} \\ & = 4,500 \times 1 \times 0.002 \times 0.3 \times 1 \\ & = 2.7 \text{ grams of plutonium} \end{aligned}$$

The SAR evaluated the dose to the off-site MEI, located at the Royal Crest Trailer Court, 2,952 feet (900 meters) from TA-55-4, using 95th percentile meteorology. The calculated exposure was 8.1 rem TEDE (LANL 1996k).

No Action Alternative Frequency Analysis

There are two types of containers for which analyses must be made. Most containers in the vault are closed such that some pre-existing failure would be necessary in order to get a release from dropping the container. This applies to 7,200 total containers, less those that do not meet this criterion (1,370), or a total of 5,830 containers. The frequency of this scenario can be evaluated using the following equation:

$$F_{\text{DROP}} = N_{\text{CONT}} \times H_{\text{DROP}} \times C_{\text{INNER}} \times C_{\text{OUTER}} \times C_{\text{HEPA}} \times H_{\text{HVAC}}$$

where:

F_{DROP} = Frequency of dropped container resulting in unfiltered release of plutonium

N_{CONT} = Number of containers handled per year

H_{DROP} = Human error probability (HEP), dropping a container

C_{INNER} = Conditional probability of a degraded inner container

C_{OUTER} = Conditional probability of a degraded outer container

C_{HEPA} = Conditional probability of HEPA failure

H_{HVAC} = Human error probability, failure to terminate HVAC system with HEPA filters failed and stack monitor alarming

The number of containers handled per year, based on the DNFSB 94-1 program being completed in the year 2002, is 1,200 containers per year. Of these, 5,830 have seals that would require a pre-existing failure, or a rate of 972 per year. It is assumed that containers are handled only once before being placed into DOE Standard 3013-96 containers.

The HEP in dropping a plutonium container is estimated at 0.001 per demand. This value is applicable to a checker failing to check the status of equipment if the status of the equipment affects one's safety when performing the task (Swain and Guttmann 1983). This error rate is judged to most closely represent the circumstances involved in retrieving a container of plutonium from the vault at TA-55-4.

The conditional probabilities of failed outer and inner containers are estimated at 0.055 and 0.02, respectively, based on LANL-specific data (LANL 1996p). The conditional probability of

the HEPA system being failed is evaluated based on LANL-specific data from 1990 to 1994 (LANL 1990b, LANL 1991b, LANL 1994c, LANL 1994d, and LANL 1995h), and considered a two-stage HEPA filter system (LANL 1996k). The 1990 to 1994 data indicate a 5 percent failure rate for HEPA filters. However, there is differential pressure measuring instrumentation installed between the HEPA filters in series, which alarms when it detects failure of a filter. In order for HEPA filters in series to fail, both the HEPA filters and the differential pressure instrumentation indicating failure of filters must fail. Considering two filters in series, this yields a HEPA failure rate of 0.05×0.05 , or 2.5×10^{-3} for the HEPA filters, and an additional conditional probability of 5×10^{-3} for failure of a single instrument channel covered by a preventive maintenance program and related administrative procedures (Mahn et al. 1995). Thus, the overall HEPA filter failure probability is $(2.5 \times 10^{-3}) \times (5 \times 10^{-3})$, or 1.3×10^{-5} per demand.

H_{HVAC} is a proceduralized action. The Human Reliability Handbook identifies a basic HEP for these circumstances of 0.025 per demand (Swain and Guttman 1983). A shift supervisory function also would be staffed and would be expected to respond if the operator does not. The HEP for this function is 0.1 (Swain and Guttman 1983). The total HEP for H_{HVAC} is 0.025×0.1 , or 2.5×10^{-3} per demand.

Based on these considerations, the above equation can be quantified as follows:

$$\begin{aligned}
 F_{DROD} &= N_{CONT} \times H_{DROD} \times C_{INNER} \times C_{OUTER} \\
 &\quad \times C_{HEPA} \times H_{HVAC} \\
 &= 972 \times 0.001 \times 0.055 \times 0.02 \times (1.3 \times 10^{-5}) \times \\
 &\quad (2.5 \times 10^{-3}) \\
 &= 3.5 \times 10^{-11} \text{ per year}
 \end{aligned}$$

The frequency of such a scenario affecting only facility workers is much higher because the

C_{HEPA} and H_{HVAC} terms disappear from the frequency equation (it is not necessary to have HEPA or HVAC failures to affect workers inside the facility). Quantified for workers, the frequency becomes 1.1×10^{-3} per year.

The remaining 1,370 containers are food pack cans, dressing jars, or other similar containers. These containers were used to pack plutonium metal (LANL 1996k). In addition, these containers lack a hermetic seal, which can lead to oxidation of the metal and failure of the inner containers. Corrosion of the metal by organic compounds caused by alpha-particle-induced decomposition of the plastic also can occur. Finally, degradation of taped seals on containers and plastic bags around the inner containers makes the containers susceptible to rupture during handling or if dropped (LANL 1996k). For these reasons, the conditional probability of a degraded container is taken as 1.0.

The following equation applies:

$$F_{DROD} = N_{CONT} \times H_{DROD} \times C_{HEPA} \times H_{HVAC}$$

where:

F_{DROD} = Frequency of dropped container resulting in release of plutonium

N_{CONT} = Number of containers handled per year

H_{DROD} = Human error probability, dropping a container

C_{HEPA} = Conditional probability of HEPA failure

H_{HVAC} = Human error probability, failure to terminate HVAC system with HEPA filters failed and stack monitor alarming

The number of containers is 1,370, divided by the 6-year period of the 94-1 program, or a rate of 228 per year.

Based on the information presented above, the equation can be quantified as follows:

$$\begin{aligned} F_{\text{DROP}} &= N_{\text{CONT}} \times H_{\text{DROP}} \times C_{\text{HEPA}} \times H_{\text{HVAC}} \\ &= 228 \times 0.001 \times (1.3 \times 10^{-5}) \times (2.5 \times 10^{-3}) \\ &= 7.5 \times 10^{-9} \text{ per year} \end{aligned}$$

Clearly, these containers dominate the overall frequency. However, the overall frequency is extremely low. Based on detailed frequency quantification, it was determined that the qualitative binning of this sequence into the 10^{-6} to 10^{-4} per year frequency bin in the TA-55 SAR is excessively conservative, and that this scenario screens on low frequency. On a deterministic basis, so many failures and/or human errors are required for a release to the environment to occur from this scenario that the scenario is not credible.

The frequency of such a scenario affecting a worker is different because the C_{HEPA} and H_{HVAC} terms disappear from the frequency equation (it is not necessary to have HEPA or HVAC failures to affect workers inside the facility). Quantified for workers, the frequency becomes 0.228 per year, or about one every 5 years. This would place this scenario into an expected occurrence. The quantification is conservative in that it assumes every time a container is dropped a spill results. This scenario has been included as a strictly worker accident in section G.5.7.5.

Uncertainties and Sensitivities Affecting the Frequency of RAD-10

Regardless of the sensitivities and uncertainties in the frequency of this scenario, the absolute frequency is extremely small and would not result in a credible scenario frequency even if more conservative values were used in quantification. The scenario is screened from further analysis.

Source Term Calculations

Source term calculations followed the general DOE Handbook 3010-94 process, with the ARF and RF selected therefrom (DOE 1994d, page 4-9) and are also those used for this spill. The DR is 1 (the entire contents of the container are spilled), and the LPF = 1 with the HEPA filters failed (this is very conservative). Thus, the source term equation can be quantified as follows:

$$\begin{aligned} \text{Initial Source Term} &= \text{MAR} \times \text{DR} \times \text{ARF} \times \\ &\quad \text{RF} \times \text{LPF} \\ &= 4,500 \times 1 \times 0.002 \times 0.3 \times 1 \\ &= 2.7 \text{ grams weapons-grade plutonium} \end{aligned}$$

The suspension source term calculation also is performed according to DOE Handbook 3010-94. The ARR and RF values for a powder spill are 0.00004 and 1.0, respectively, for a homogeneous bed of powder exposed to normal process ventilation flow (it is conservative to assume that the ventilation system is not turned off). Quantification is for 24 hours (this is potentially very conservative for a spill inside the facility). The suspension source term equation is quantified as follows:

$$\begin{aligned} \text{Suspension Source Term} &= \text{MAR} \times \text{DR} \times \\ &\quad \text{ARR/hr} \times 24 \text{ hrs} \times \text{RF} \times \text{LPF} \\ &= (4,500 - 2.7) \times 1 \times 0.00004 \times 24 \times 1 \times 1 \\ &= 4.3 \text{ grams of weapons-grade plutonium} \end{aligned}$$

There are no differences in source term across the alternatives.

Uncertainties and Sensitivities Affecting the Source Term for RAD-10

The assumption of an LPF of 1 with the ventilation on and the HEPA filters failed is extremely conservative. It would be expected that, by procedure in response to stack radiation alarms, the ventilation system would be shut

down as soon as the HEPA filter failure was discovered, which would take the LPF from 1 to 0.011. The assumption of a 24-hour suspension period for this process-oriented event is also potentially very conservative because the spill would be expected to be cleaned up well before 24 hours.

Another significant uncertainty is the quantity of plutonium in the container. The analysis assumes the maximum allowed (4,500 grams). In reality, the amount could be smaller, resulting in a smaller source term.

Consequences of RAD-10 for Facility Workers and the Public

Consequences are discussed separately for facility workers and the public. The workers retrieving the container that is dropped and fails could be exposed to plutonium inhalation, with substantial doses possible depending upon the usage of PPE and the speed with which the worker(s) is able to exit the immediate area.

The public consequences are summarized in Table G.5.6.10-1. It must be understood that the worker consequences occur at a much higher frequency. As indicated above, the likelihood of public consequences from this scenario is extremely small and considered to be incredible under NEPA practice. The likelihood of worker consequences is much higher, ranging from 1.1×10^{-3} to 0.22 per year for the two contributing scenarios.

No acute fatalities are predicted to result from the postulated accident. The mean collective population dose is projected to total 560 person-rem (TEDE), resulting in 0.28 excess LCFs. Mean projected doses for MEIs (and their associated locations) and ground contamination levels are presented in Tables G.5.6.10-2 and G.5.6.10-3, respectively.

G.5.6.11 *RAD-11, Container Breach After Detonation of Plutonium-Containing Assembly at DARHT*

General Scenario Description

General information on the DARHT Facility and its function and mission is provided in RAD-04. As stated in RAD-04, the DARHT EIS included analysis of potential accidents, including bounding accidents that were selected and evaluated on a “what-if” basis (DOE 1995a) based on potential consequences, with little or no consideration of the frequency of occurrence, though the likelihood of occurrence would be small. Scenario RAD-11 represents the failure of a double-walled steel containment system following the detonation of a plutonium-containing assembly. As noted earlier in the DARHT EIS, in related safety analyses these accidents have been evaluated to be not credible (probability less than 10^{-6} per year). Although some hundreds of dynamic experiments may be conducted per year, only a small number will contain plutonium (LANL 1996m), and these experiments would not reasonably be expected to result in any release of plutonium to the environment (DOE 1995a).

As explained in greater detail in the DARHT EIS, the accident scenario RAD-11 involves the failure (breach) of a double-walled steel containment system following the planned detonation of a plutonium-containing assembly to be radiographed at DARHT or at the existing PHERMEX Facility located a short distance away. Some dynamic experiments involve plutonium in order to obtain needed information and understanding associated with nuclear weapons aging and continued assurance of weapon safety and performance (DOE 1995a). As a matter of policy, these experiments will always be conducted inside a double-walled steel containment system consisting of an inner confinement vessel and an outer safety vessel to prevent plutonium release; furthermore, the

TABLE G.5.6.10-1.—Summary Results for Scenario RAD-10

ALTERNATIVE	ACCIDENT FREQUENCY	SOURCE TERM AND CONSEQUENCES
No Action	Incredible	2.7 grams of weapons-grade plutonium released initially from the stack, 4.3 grams subsequently released in 24 hours due to suspension; integrated population exposure of 560 person-rem, 0.28 excess LCFs.
Expanded Operations	Incredible	Same as No Action Alternative.
Reduced Operations	Incredible	Same as No Action Alternative.
Greener	Incredible	Same as No Action Alternative.

TABLE G.5.6.10-2.—Predicted Mean Doses to MEIs for Scenario RAD-10

MAXIMUM EXPOSED INDIVIDUAL (MEI) DOSE (REM, TEDE)	
MEI LOCATION	DOSE
Closest Public Access: Pajarito Road (50 m)	44
Closest Residence: Royal Crest Trailer Park (900 m)	1.1×10^0
Special Population Distance: Los Alamos Hospital (1,200 m)	3.2×10^{-1}
Special Population Distance: San Ildefonso Pueblo boundary (3,900 m)	1.5×10^{-1}
Special Population Distance: San Ildefonso Pueblo (17,000 m)	1.1×10^{-2}

TABLE G.5.6.10-3.—Predicted Mean Ground Contamination Levels for Scenario RAD-10

RADIAL DISTANCE	PLUTONIUM-239 GROUND CONCENTRATION (BQ/m ²)
0.0 to 1.0 km	5.7×10^3
1.0 to 2.0 km	2.3×10^3
2.0 to 3.0 km	1.2×10^3
3.0 to 4.0 km	7.1×10^2
4.0 to 8.0 km	3.1×10^2
8.0 to 12.0 km	1.2×10^2
12.0 to 20.0 km	5.0×10^1
20.0 to 30.0 km	2.0×10^1
30.0 to 40.0 km	1.1×10^1
40.0 to 60.0 km	5.4×10^0
60.0 to 80.0 km	2.9×10^0

experiments will always be arranged and conducted in such a manner that a nuclear explosion could not result (DOE 1995a).

The impacts of the hypothetical RAD-11 containment breach scenario are similar to but less than those for the hypothetical uncontained detonation scenario of RAD-04. For the RAD-11 scenario, no immediate worker deaths would be anticipated due to the high-explosives blast causing the containment breach because involved workers would be sheltered at the time of test execution. The human health impacts to the public and to noninvolved workers are dominated by the explosive aerosolization of plutonium, which is then released through a breach in the double-walled containment and atmospherically dispersed. In the DARHT EIS, DOE examined the environmental consequences that could occur if the outer vessel were breached with a 1-inch hole (DOE 1995a). Up to tens of excess LCFs based on a 50-year committed dose would result from this hypothetical scenario, depending on the population sector assumed to be exposed due to extant winds. Impact analysis for this SWEIS is taken directly from the analysis DOE has already performed and received comment on from the public; other agencies; and state, local, and Tribal governments in the DARHT EIS. For the convenience of the public and the decision maker, some of that information also is directly reproduced in this SWEIS (section G.5.6.4). The methodology and all impacts associated with this hypothetical containment failure are principally contained in Chapter 5 and Appendixes H, I, and J of that EIS; additional information is contained in a classified appendix.

No Action Alternative Frequency Analysis. The frequency of this scenario is evaluated as incredible (i.e., less than 10^{-6} per year), as was indicated the DARHT EIS (DOE 1995a). This frequency is corroborated by DOE safety analyses.

Expanded Operations, Reduced Operations, and Greener Alternatives Frequency Analysis. No differences in frequency across the SWEIS alternatives have been identified that would alter the designation of this scenario as having a frequency of less than 10^{-6} per year, as discussed in the DARHT EIS. The frequency categorization for the No Action Alternative is assumed to be applicable across the SWEIS alternatives.

Source Term Calculations. As described in the DARHT EIS (DOE 1995a), analysis of this hypothetical accident is documented in a classified appendix to that EIS. While the resulting impacts, as well as unclassified calculations, assumptions, and modeling methods, are contained in the unclassified sections of the EIS, some details of such experiments, including some associated with the source terms for this accident scenario, are classified.

Consequences of RAD-11 for Facility Workers and the Public. Impacts to involved workers, noninvolved workers, public populations and MEIs, were described in the DARHT EIS. Under this scenario, there would be no impact to workers, who would be sheltered during the detonation and subsequent breach of the vessel system.

Predominant human health impacts to noninvolved workers or the public would stem from exposure to aerosolized and dispersed material. Impacts to noninvolved workers at distances of 2,500 and 1,300 feet (750 meters and 400 meters) were evaluated (DOE 1995a). Doses to noninvolved workers were estimated to be 60 rem and 20 rem for a worker at 1,300 feet and 2,500 feet (400 meters and 750 meters), respectively; corresponding probabilities of excess LCFs would be 0.02 and 0.009, respectively, for such individuals. LANL administratively controls access to explosives areas by noninvolved individuals and has a set of established hazard radii for protection of personnel from fragment injury

from explosives experiments, based on DOE principles. It was estimated that a noninvolved worker would likely be no closer than 2,500 feet (750 meters). The public MEI located at State Road 4 was calculated to receive 14 rem, with a resulting probability of an excess LCF of 0.007 (DOE 1995a).

The population exposure for the most populated sector (which includes White Rock and Santa Fe) was estimated to be between 210 and 560 person-rem for 50th and 95th percentile meteorological conditions, respectively, resulting in negligible excess LCFs (DOE 1995a). While diffusion of material across an entire directional sector was taken into account, it was assumed that all of the community populations were located at or near to the plume center line, a conservative assumption that results in an overestimate of impacts (DOE 1995a). Impacts for both workers and the public also can be found in tabular form in Table I-10 and Table I-11 in the DARHT EIS, which is reprinted for convenience in this SWEIS in section G.5.6.4. These tables show impacts from both the uncontained detonation and containment breach scenarios on a what-if basis. Population dose and impacts to other communities also were calculated for the inadvertent detonation accident, which is the bounding case, and can be seen in RAD-04 (section G.5.6.4). Table G.5.6.11-1 summarizes these results.

G.5.6.12 *RAD-12, Plutonium Release from a Seismically Initiated Event*

General Scenario Description

The accident scenario discussed here is an explosively driven release of plutonium from building TA-16-411. This scenario is similar to that of RAD-04, but would be specific to the TA-16-411 facility because it supports existing high explosives operations. The explosive dispersal would be initiated by the collapse of appropriate parts of this structure during an earthquake, during one of the short periods when an explosive assembly including plutonium would reside in this facility. In this scenario, the seismic collapse is postulated to cause high explosives to detonate and, in the process, aerosolize a portion of the plutonium as respirable particles. Although it could be expected from the collapse of the building that a portion of the material (including respirable particles) would be trapped by the debris and unavailable for atmospheric transport. For this case it was conservatively assumed that there was no trapping of material relative to an uncontained, open-air explosives release.

The scenario is considered marginally credible based on recent safety analyses, and may fall at or below the screening criteria cutoffs (to “incredible”) as more detailed analysis is developed. New studies have demonstrated that the frequency of such an accident would

TABLE G.5.6.11-1.—Summary Results for Scenario RAD-11

ALTERNATIVE	ACCIDENT FREQUENCY	INTEGRATED POPULATION DOSE (PERSON-REM, TEDE)	EXCESS LCFs
No Action	< 10 ⁻⁶	210	.01
Expanded Operations	< 10 ⁻⁶	210	01
Reduced Operations	< 10 ⁻⁶	210	01
Greener	< 10 ⁻⁶	210	01

decrease based on more detailed and thorough (yet still conservative) evaluation of the structural robustness of the vault of building TA-16-411 (the only part of the structure where these materials would reside) to withstand earthquakes. These studies are currently under review by LANL and DOE. Similarly, other factors of conservatism are included in the current assessment of probability of this scenario.

No Action Alternative Frequency Analysis

Because this accident scenario is a seismically initiated event, the capacity of the building to withstand an earthquake is a key factor in determining the frequency of the accident. TA-16-411 includes a vault structure attached to an older main building. Because high explosives and plutonium material would only be present within the vault structure, it is the capacity of the vault to withstand earthquakes, not that of the less-robust older part of the structure, that relate to the probability or frequency of this scenario.

The vault and its major components in TA-16-411 are known to have a significantly greater capacity to resist damage from an earthquake than the older main structure. Highly conservative analyses based on simple statistical modeling of the vault structure showed the vault would withstand earthquakes in the SITE-01 grouping of earthquake magnitudes (0.04 to 0.1 g), but were consistent with a low probability of failure from earthquakes of about 0.3 g, in the SITE-03 range. This means that we have a great deal of confidence that the vault will not fail for higher frequency earthquakes, and are therefore very conservative in estimating a failure of the vault at these stated values.

Note that in the SITE-01 estimates of the HCLPF values, the building as a whole corresponds to 0.05 g, which lies in the range designated as the SITE-01 grouping of earthquake magnitudes (0.04 to 0.10 g). The

HCLPF value related to the structure as a whole is limited by the older main structure; this magnitude earthquake would correspond to a frequency of 3.5×10^{-3} .

The overall accident frequency is lower than the estimated earthquake occurrence frequency because of further conditional probabilities of an earthquake occurring when the high explosives components are in the vault because they are not housed in the vault on a continuous basis. Finally, these explosives are not highly susceptible to detonation from low impact mechanical shocks, such as falling debris.

Because the vault is the only relevant component of the building, the overall frequency based on this seismic analysis would be on the order of magnitude of 4×10^{-6} , near the screening threshold for credible accidents in this SWEIS.

More recently, a more thorough dynamic modal analysis of this structure (still based on conservative principles) performed under contract to LANL has indicated that the structure would have a high confidence of withstanding at least 0.31 g earthquakes. This would reduce the frequency associated with this accident scenario to about 1.5×10^{-6} or lower. More precise estimates of this frequency may be available by the time the Final SWEIS is prepared. At this frequency, the accident is marginally credible when conservatively analyzed. More realistic, but still conservative, assumptions could reduce this frequency to below 10^{-6} ; however, to be conservative, this scenario is included in the Draft SWEIS as marginally credible.

Expanded Operations, Reduced Operations, and Greener Alternatives

Because this building will be used under all alternatives, the frequency values would remain the same.

No Action Source Term Calculations

Some details associated with the source terms for this accident scenario are classified. No credit is taken for entrapment of the material by building debris, so all of the respirable particles are considered available for atmospheric transport.

Consequences for Facility Workers

The workers in the facility would be killed by the explosion or falling debris. No doses were evaluated because it would be highly unlikely that anyone would survive such an event.

Consequences for the Public

As noted earlier, different methodologies may be used to evaluate atmospheric dispersal and human health impacts; it is understood in this analysis that there is a range of uncertainty associated with such models. Conservatism is included through a variety of approximations and assumptions. For this accident scenario, the equations used to define the initial plume dimensions and plume centerline height are those recommended in *Plutonium Explosive Dispersal Modeling Using the MACCS 2 Computer Code* (Steele et al. 1997). The Julick System (Vogt 1997) derived for 164-foot (50-meter) plumes is used for determining the downwind expansion of the Σ_y and Σ_z terms. The plume meander option was not activated.

The duration of the emergency phase was defined as 1 day. It was assumed that no emergency phase mitigative actions (evacuation or sheltering) were implemented to reduce emergency phase exposures. For doses from the inhalation of resuspended particles, chronic population exposures were to be mitigated by decontamination, temporary interdiction, or condemnation of contaminated property, if doses exceeded 2 rem in the first year following the accident. This criterion is a generalization of EPA guidance that recommends dose mitigative actions if it is projected that

individuals will receive 2 rem in the first year following the accident (EPA 1991).

The integrated population numbers are given for both the public within a 50-mile (80-kilometer) radius and, separately, the LANL workforce populations. Note that adding these numbers represents a conservative number. LANL employees who work at the site and live within the area are counted twice for the integrated population doses.

Table G.5.6.12-1 is a summary of the consequences for this scenario. Table G.5.6.12-2 is a summary of the overall risks for this scenario. The MEI locations calculated for this scenario are given in Table G.5.6.12-3.

G.5.6.13 *RAD-13, Plutonium Release from Flux Trap Irradiation Experiment*

General Scenario Description

The Skua fast-burst reactor, housed at Kiva #3 at Pajarito Site (TA-18-116) can be used for irradiation of experiments within a cavity in the reactor core, called a flux trap. These experiments would be carried out inside Kiva #3 (LANL 1996f). The bounding experiment modeled here is a shock rod experiment; other experiments, involving less severe conditions and far less MAR, may also be carried out in the Skua flux trap. The intent of a shock rod experiment is to measure the stress generated in a sample of fissile material by the rapid heating caused by fissions induced by the neutron pulse. The accident scenario involves a shock rod experiment in which the maximum design pulse of power is delivered to the experiment, rather than the lower intended power. The oversized pulse results in a very high energy deposition in the shock rod, resulting in melting (but not vaporization) of 6,000 grams of plutonium.

TABLE G.5.6.12-1.—Consequences for Accident Scenario RAD-12

LANL WORKFORCE POPULATION DOSES (TEDE, PERSON-REM)	EXCESS LATENT CANCER FATALITIES	OFF-SITE POPULATION DOSES (TEDE, PERSON-REM)	EXCESS LATENT CANCER FATALITIES
7,800	3.9	28,000	14

TABLE G.5.6.12-2.—Overall Risks for Accident Scenario RAD-12

ALTERNATIVE	ACCIDENT FREQUENCY (EVENT/YR)	INTEGRATED POPULATION DOSE (TEDE, PERSON-REM)	EXCESS LATENT CANCER FATALITIES
No Action	1.5×10^{-6}	35,800	18
Expanded Operations ^a	No change	No change	No change
Reduced Operations ^a	No change	No change	No change
Greener ^a	No change	No change	No change

^a No change is noted with regard to the No Action Alternative.

TABLE G.5.6.12-3.—Predicted MEI Doses for Scenario RAD-12

MEI LOCATION	DOSE
100 m	87
Closest Site Boundary: 550 m	138
Closest Residential Population: 5.2 km	18

Note that no such experiments have been conducted to date at TA-18. Thus, the TA-18 SAR analysis concerns a capability to perform such experiments, rather than an intention to do so. (Shock rod experiments have been performed at SNL using the SPR-II fast-burst reactor, and are discussed in the SARs of both SPR-II and SPR-III.)

Shock rod experiments can be carried out using highly enriched uranium (largely, uranium-235) or plutonium (largely, plutonium-239) (LANL 1996f). However, because the expected fuel failure and resultant hazards of uranium experiments are much lower than for plutonium rods, the TA-18 SAR analysis focused on the plutonium shock-rod experiments (LANL 1996f). The SWEIS accident analysis also concerns plutonium shock rod experiments for the same reasons.

Plutonium experiments with the Skua fast-burst assembly are required to incorporate two levels of containment; but, the TA-18 SAR analysis assumes no containment (LANL 1996f and Paternoster et al. 1995). However, even if containment is used, the SAR calculations indicate that a final liquid temperature of about 3,600°F (2,000°C) is achieved. Because the melting temperature of a range of stainless steels used as glory-hole liners is 2,552 to 2,732°F (1,400 to 1,500°C), rupturing of the steel liner in the containment device would be expected, which would allow the molten plutonium to contact air. Because the ignition temperature of plutonium in air is about 930 to 1,100°F (500 to 600°C) (depending on the surface area of the plutonium), a plutonium fire would occur (LANL 1996f).

This accident scenario was analyzed in the TA-18 SAR. No accident sequence frequency was estimated or calculated in the SAR, nor was a frequency bin assignment made. Rather, the SAR stated that all of the accidents analyzed were incredible, implying a frequency of less than 10^{-6} per year. The source term was calculated assuming a release fraction of 0.001

from the melt (i.e., 6 grams of plutonium). Release into the environment was modeled based on exfiltration through the confinement structure and dispersal downwind. The source term also took into consideration the fission products generated during the burst of neutrons to the target material (LANL 1996f).

No Action Alternative Frequency Analysis

No shock rod experiments have been performed at TA-18, nor are any such experiments planned under any of the SWEIS alternatives. The TA-18 SAR analysis is more by way of providing SAR assessment space so that if the need arises, the capability to conduct shock rod experiments can be realized without a lengthy administrative delay that could otherwise be needed in order to amend the SAR. Accordingly, any frequency assignment for this accident scenario will necessarily be speculative.

Nevertheless, some perspective on the likelihood of the accident scenario can be gained by considering what sorts of failures would be necessary in order for the accident to take place. Both the TA-18 SAR and the SAR for the SPR-III facility at SNL characterize the accident as probable because it can occur at the design power level of the fast-burst reactor used to conduct the experiment (LANL 1996f). Based on DOE Standard 3009-94 (DOE 1994d), this is interpreted to mean that the accident is credible, but very unlikely, representing a design basis accident. This would place the accident scenario into the 10^{-6} to 10^{-4} per year frequency bin.

The most likely cause of the accident would be a chain of human errors leading to an excessive power level (but still within Skua design levels) being used for the experiment, although it is feasible that an undetected design or fabrication error could also lead to the accident. Typical human error rates for tasks generally are in the range of 10^{-4} to 10^{-2} (Mahn et al. 1995 and Swain and Guttmann 1983). Considering the

fact that tests at TA-18 are performed under a testing plan and an experiment plan, these additional levels of administrative control suggest that the lower end of this range of human error rates is more reasonable as a basis for quantification. The probability of errors for a checker of someone else's work is expected to be higher than the probability of the original error because the checker does not normally completely redo the calculations when evaluating someone else's work. This represents a special case of dependence in human reliability analysis (Swain and Guttman 1983). The basic recommended error rate for a checker is 0.1 when using written procedures; for a one-of-a-kind check (nonroutine), the recommended value is 0.05 because the checker would be expected to approach this task with a higher level of alertness for possible errors (Swain and Guttman 1983).

Also important for the particular accident under evaluation here is that the opportunities for recovery from the error during the pulse operation are extremely limited once the calculation checks have been completed. This is due to the nature of the event. That is, once the experiment has been set up and the operation initiated, the neutron pulse happens in a tiny fraction of a second, and there is no chance to recover from the error or mitigate the consequences of the event (apart from emergency response).

Considering the above, the human error rate in experiment operation might be of the order of 5×10^{-7} per experiment ($0.0001 \times 0.05 \times 0.1$), assuming one initial error and two failed checks. Even this estimate implicitly assumes that all errors lead to the fuel melting outcome; this is clearly incorrect because not all operational errors are catastrophic. Clearly, a plutonium melting accident arising from a shock rod experiment is not very likely.

It is also possible that an error in maintenance or calibration could lead to a higher than intended power level being delivered to a shock rod

experiment. This would also require at least two errors (the initial error and the failure of the checker to detect the error). If independence between these errors is assumed, a typical HEP for test, maintenance, and calibration activities that leaves a component or system with an unrevealed fault is 10^{-3} per demand, with a range from 3×10^{-4} to 3×10^{-3} per demand (Mahn et al. 1995), with the lower end of the range being more reasonable, given the administrative controls mentioned above. Given the unique nature of a shock rod experiment for LANL, the appropriate checker failure rate would be 0.05. This would yield a value of about 1.5×10^{-5} ($0.0003 \times 0.05 = 1.5 \times 10^{-5}$). However, not all errors are equally serious or would necessarily lead to a power level resulting in shock rod melting (e.g., some errors would lead to the inability to conduct the pulse, with an investigation into the cause being very likely to identify the error and lead to its correction.) Again, a plutonium melting accident arising from a shock rod experiment is not very likely.

Consistent with the sliding-scale approach in DOE NEPA guidance (DOE 1993b), the frequency of this accident is set to 1.6×10^{-5} per experiment for all alternatives (the sum of the conditional frequencies of the two contributing error modes). (This frequency is carried forward as one experiment per year.)

Expanded Operations, Reduced Operations, and Greener Alternatives Frequency Analysis

This accident is independent of the alternatives. The activity that could give rise to this accident has not yet been performed at LANL and is not scheduled to be performed. The accident models a capability to perform the activity. Therefore, there is no reason to assess a variation in frequency across the alternatives.

Uncertainties and Sensitivities Affecting the Frequency of RAD-13

The accident frequency calculation documented above is speculative. However, given that the experiment has not been performed at LANL and that there are no current plans to perform the experiment, the frequency estimate is considered to be representative of what might be expected for circumstances under which the experiment is conducted infrequently (once per year or less).

Source Term Calculations

The TA-18 SAR employed a respirable release fraction (ARF x RF) of 0.001. This assessment was based on assuming 6,000 grams of plutonium melted and that this entire amount is distributed for optimum dispersal (LANL 1996f). The SAR analysis does not make reference to DOE Handbook 3010-94. The SNL SPR-III SAR analysis predates the LANL analysis, and mirrors it in most respects. One notable difference, however, is that the LANL release fraction is five times lower than the SNL release fraction (0.001 versus 0.005).

The source term was quantified for the SWEIS according to DOE Handbook 3010-94 guidance. The MAR is 6,000 grams of weapons-grade plutonium in molten (liquid) form (LANL 1996f). The DR is assessed as 1.0 (all 6,000 grams are molten).

The LPF is not directly calculated or estimated in the TA-18 SAR. Because the SAR assessed no driving force associated with the accident, the release from the kiva was modeled as wind-driven exfiltration. Over a 2-hour period, the release fraction (which is dependent on wind speed) ranges from 0.05 to 0.25 for wind speeds in the range from 1 to 10 miles per second (2.2 to 22.3 miles per hour) (LANL 1996f). Because typical upslope and downslope winds at Los Alamos are in the range of 2.5 to 3 miles (4.0 to 4.8 kilometers) per second (LANL 1990a), DOE has selected an LPF of 0.1 (which is

between the values for 2 and 3 miles [3.2 to 4.8 kilometers] per second).

Selection of appropriate ARF and RF values is complicated by the limited description of the accident scenario in the LACEF SAR. The SAR acknowledges the possibility that rupturing the containment vessel could allow molten plutonium to slump to the assembly stand and adjacent areas. For airborne release of particulates from disturbed molten metal surfaces (i.e., flowing metal, actions resulting in continuous surface renewal), DOE Handbook 3010-94 recommends the bounding ARF and RF values of 0.01 and 1.0, respectively (DOE 1994d). The handbook clarifies that the bounding value applies to situations where ignited, molten plutonium is disturbed by direct impact of high air velocities such as during free fall (DOE 1994d).

The handbook also addresses a circumstance involving the airborne release of particulates formed by self-sustained oxidation (molten metal with oxide coat), self-induced convection. The handbook clarifies that this applies to self-sustained oxidation in air of metal pieces (DOE 1994d). The ARF and RF values for this circumstance are 0.0005 and 0.5, respectively.

ARF and RF bounding values for these two sets of circumstances yield initial source terms as follows:

Self-Sustained Oxidation

$$\begin{aligned} \text{Source Term} &= \text{MAR} \times \text{DR} \times \text{ARF} \times \text{RF} \times \\ &\quad \text{LPF} \\ &= 6,000 \times 1 \times 0.0005 \times 0.5 \times 0.1 \\ &= 0.15 \text{ grams} \end{aligned}$$

Disturbed Molten Metal Surfaces

$$\begin{aligned} \text{Source Term} &= \text{MAR} \times \text{DR} \times \text{ARF} \times \text{RF} \times \\ &\quad \text{LPF} \end{aligned}$$

$$= 6,000 \times 1 \times 0.01 \times 1 \times 0.1$$

$$= 6.0 \text{ grams}$$

The suspension source-term calculation was also performed according to DOE Handbook 3010-94 guidance:

$$\text{Suspension Source Term} = \text{MAR} \times \text{DR} \times$$

$$\text{ARR/hr} \times 24 \text{ hrs} \times \text{RF} \times \text{LPF}$$

$$= 6,000 \times 1 \times 0.00004 \times 24 \text{ hrs} \times 1 \times 0.1$$

$$= 0.6 \text{ grams}$$

The ARR and RF values are based on powder located inside a building with ambient conditions (DOE 1994d). This was considered to be appropriate because the melted plutonium released from the containment device will burn on contact with air and change the physical state of the plutonium.

In addition to the plutonium source term from the melting event, a radiological release will occur as a result of the generation of fission products due to the neutron pulse. The large majority of fission products have very short half-lives (on the order of 0.21 seconds to 3.15 minutes) and their mode of decay is primarily by beta and gamma emission. The SAR analysis assigned an average dose-rate conversion factor for air immersion (cloudshine) of 4,000 millirem-cubic meter per microcurie per year to those beta-gamma emitting radionuclides not having documented values. Comparison of the decay product quantities and dose conversion factors with the plutonium source term values indicated that the fission products provide a negligible contribution to the total dose from internal exposure pathways. Consequently, doses resulting from internal exposure pathways for fission products were not modeled. Doses resulting from the external exposure pathway (air immersion) for fission products (6.02×10^3 curies) were estimated using the SAR-determined average dose-rate conversion factor

of 4,000 millirem-cubic meter per microcurie per year.

The accident does not change across the alternatives. The No Action Alternative source term applies to all of the SWEIS alternatives.

Uncertainties and Sensitivities Affecting the Source Term for RAD-13

The source term for RAD-13 is very sensitive to the accident progression, which has unfortunately not been evaluated in detail past the point where the plutonium melts. If the accident progression is relatively benign (involving low pressure melting of the container and candling of the molten liquid down the sides of the Skua device), then the SAR source term is probably conservative. If, however, a more energetic surface reaction occurs in the molten material, then the SAR estimate of the source term is possibly too low.

One uncertainty in this case would be how much of the plutonium would actually be ejected, versus the amount that would cool and freeze to the interior surface of the container. Finely divided liquid plutonium metal at high temperature would be expected to be energetically pyrophoric with the air inside the kiva. The rate of oxidation of plutonium is dependent on: (1) temperature, (2) the surface area of the reacting metal, (3) the oxygen concentration, (4) the concentration of moisture and other vapors in the air, (5) the type and extent of alloying, and (6) the presence of a protective oxide layer on the metal surface (DOE 1994d). Factors 1 and 2 are maximized under the conditions hypothesized; indeed, the plutonium would initially be far above the ignition temperature (i.e., 2,000°F [1,093°C] at release versus the ignition temperature of 914°F to 932°F [490 to 500°C]). Factor 3 is essentially unlimited because oxygen in the air would be replenished from outside the kiva. Factor 6 is not applicable because the plutonium is in a liquid form. The source term from this

configuration could be significantly higher than calculated above.

Consequences of RAD-13 for Facility Workers and the Public

Consequences for facility workers and the public are discussed separately. The Kiva #3 control room is located 669 feet (204 meters) from the kiva (LANL 1996f). The walls of the control room are such that 40 percent attenuation of gamma doses from the outside is accomplished (LANL 1996f). In the event of an accident, ventilation systems for the control building (TA-18-30) would be secured. Air exchange with the outside would be a function of wind loading and diffusion in and around wall and ceiling penetrations (LANL 1996f). However, the ventilation system for the control building is not protected by HEPA filters (LANL 1996f).

No acute fatalities are predicted to result from the postulated accident. The mean collective population dose is projected to total 160 person-rem (TEDE), resulting in 0.082 excess LCFs. The public consequences for RAD-13 are provided in Table G.5.6.13-1, which summarizes the modeling results for RAD-13. Mean projected doses for MEIs (and their associated locations) and ground contamination levels are presented in Tables G.5.6.13-2 and G.5.6.13-3, respectively.

G.5.6.14 *RAD-14, Plutonium Release Due to Ion-Exchange Column Thermal Excursion*

General Scenario Description

This accident scenario involves the release of plutonium through the building ventilation systems during a process event. In TA-55, ion exchange columns, inside of gloveboxes, are used to separate out different plutonium compounds. As plutonium nitrate solutions are introduced into these columns, an abnormal

increase in temperature is possible. This temperature rise could be due to degraded resin, greater reactivity of the solution with the column resin, or even a limited glovebox fire.

For the accident to proceed, the column must rupture due to a pressure build up caused by the temperature rise. Aerosolized plutonium nitrate could then enter the glovebox and be drawn into the glovebox ventilation system. For any release of material into the building ventilation systems, the glovebox HEPA filter system would have to fail. For the material to reach the environment, the building HEPA filters would also have to fail. This scenario has a probability that is extremely low. The probability is low enough to be deemed incredible even though an initiating event is considered possible.

The accident would have to start from some initiating event such as: (1) inadvertent introduction of a high temperature solution causing the resins to decompose; (2) inadvertent introduction of impurities in the feed stock, such as strong oxidants; and (3) inadvertent introduction of high concentrations of nitric acid. Each of these situations, could set up a reaction in the column that quickly heats the material in the column, possibly leading to an ion-exchange column overpressurization.

Because such situations have occurred, LANL uses resins that are resistive to degradation. The vinyl pyridine polymers used in the ion exchange columns are significantly more resistant than resins incorporating a polymer of polystyrene and divinyl benzene. These resins have a marked improvement in stability for conditions of high temperature, concentrated nitric acid exposure and for conditions of high radiation. Progressive resin deterioration can be detected by decreased resin exchange capacity and the appearance of bead fragments in the effluent. The resins generally are replaced before they become seriously degraded. Even with these precautions, however, problems with resins are known to occur.

TABLE G.5.6.13-1.—Summary Results for Scenario RAD-13

ALTERNATIVE	ACCIDENT FREQUENCY	SOURCE TERM AND CONSEQUENCES
No Action	1.6×10^{-5}	Bounding, 6 grams of weapons-grade plutonium initial release, 0.6 grams of weapons-grade plutonium in suspension release over 24 hours; integrated population exposure of 160 person-rem, 0.08 excess LCFs.
Expanded Operations	1.6×10^{-5}	Same as No Action Alternative.
Reduced Operations	1.6×10^{-5}	Same as No Action Alternative.
Greener	1.6×10^{-5}	Same as No Action Alternative.

TABLE G.5.6.13-2.—Predicted Mean Doses to MEIs for Scenario RAD-13

MAXIMUM EXPOSED INDIVIDUAL (MEI) DOSE (REM, TEDE)	
MEI LOCATION	DOSE
Closest Public Access: Pajarito Road (30 m) ^a	1.2×10^2
Operations Boundary (TA-18 SAR): (200 m)	2.3×10^1
Site Boundary (TA-18 SAR): San Ildefonso Pueblo boundary (1,000 m)	1.8×10^0
Special Population Distance: Mortandad Cave (2,900 m)	2.7×10^{-1}
Receptor Distance (T-18 SAR): Population center (4,400 m)	1.2×10^{-1}
Special Population Distance: San Ildefonso Pueblo (14,600 m)	1.2×10^{-2}

^a Approximated at 50 m.

TABLE G.5.6.13-3.—Predicted Mean Ground Contamination Levels for Scenario RAD-13

RADIAL DISTANCE	PLUTONIUM-239 GROUND CONCENTRATION (BQ/m ²)
0.0 to 1.0 km	2.6×10^4
1.0 to 2.0 km	3.5×10^3
2.0 to 3.0 km	1.4×10^3
3.0 to 4.0 km	7.1×10^2
4.0 to 8.0 km	2.5×10^2
8.0 to 12.0 km	9.4×10^1
12.0 to 20.0 km	3.7×10^1
20.0 to 30.0 km	1.5×10^1
30.0 to 40.0 km	8.3×10^0
40.0 to 60.0 km	4.4×10^0
60.0 to 80.0 km	2.7×10^0

BQ/m² = Becquerel per square meter

For the accident to proceed, the pressure must buildup and cause a column rupture. Because the pressure can be relieved by either the pressure relief valve or through the output line on the column, both of these components have to fail. In other words, the pressure relief valve does not actuate and the output line on the column is blocked.

At this point in the progression, an accident has occurred; but the material is still contained in the glovebox. For the material to escape the glovebox, the HEPA filter system would have to fail, allowing material into the building ventilation system. For this accident sequence, the HEPA filter is assumed to be damaged by the rupture of the ion-exchange column. Material is then transported by the ventilation system to the building HEPA filters. Again, for this material to escape the building, the multi-staged HEPA filters on the building would have to fail. The material would now be available for atmospheric transport from the south exhaust stack.

This accident progression is used to estimate the frequency of the event. Because there are a number of barriers that must fail, the calculated accident frequency is below the screening criteria cutoffs for credible accidents. The accident has been retained, however, to illustrate the nature of defense-in-depth and how it is used to reduce the frequency and consequences of possible plutonium releases at TA-55.

Comparison of Accident Analysis in the Pit Disassembly and Conversion Demonstration Environmental Assessment and This SWEIS

DOE is preparing an EA (DOE 1998) to examine the environmental impacts of the proposed development and demonstration of an integrated pit disassembly and conversion process for fissile material disposition. The hazard analysis, used for this EA first considered a baseline of public impacts given the hypothetical case where no controls exist for

the operation. This evaluation determined that without controls the impacts to the MEI are below the DOE evaluation guidelines. The hazard analysis further quantified the expected consequences to the public, given that the building is designed to provide containment of hazardous material in the event of an accident. Given these controls, the dose to the MEI was reduced to 3×10^{-8} rem and the frequency of occurrence was reduced from 10^{-3} to 10^{-5} .

Although the consequence and frequency numbers in the EA are slightly higher than those given for this accident, i.e., in the ion-exchange column thermal excursion, the risks from the pit disassembly and conversion process are considered to fall within the envelop as established by this SWEIS. Additional control barriers, other than those outlined in the EA, exist to further reduce the frequency of an initiating event and to reduce the frequency of an event with public impacts to below the 10^{-6} screening criteria. The consequences for an unconfined release of plutonium are similar and, when taking credit for HEPA filtration, the doses become very low. Doses in this range (considering filtration) could not be distinguished from background doses. Overall, for process events, the risks from this operation would be dominated by the risks of a fire for the CMR Building.

The characterization of risk at LANL, as presented by the set of accidents in this appendix is appropriate, given consideration of the EA analysis. When considering the accident risk associated with the pit disassembly and conversion process for fissile material disposition, the risk profile for LANL (as presented for each alternative) would not change. The SWEIS risk characterization is more realistic because it includes other processes implemented through adherence to DOE safety programs, including the defense-in-depth policy.

No Action Alternative Frequency Analysis

Table G.5.6.14–1 associates the accident progression, as discussed above, with either a frequency of occurrence or a rate of failure. The terms in the table are explained in subsequent sections.

Initiator

There are several types of events that could cause a column overpressurization or rupture. Unfortunately, it is difficult to quantify the initiating event likelihood and therefore the likelihood of the overall accident. A search was done for recorded cases of column overpressurizations or ruptures. This search did not find any cited incidents. To put a bound on this initiator frequency, the ORPS database, where such incidents are systematically cataloged, was used. The last 5 years of data was considered representative of the likely initiators at LANL. No ion-exchange column overpressurization or rupture were reported in the last 5 years. Given that LANL is operated for approximately 260 days per year, the frequency of occurrence is less than 1 event in 1,300 days, or a rate of less than 8×10^{-4} per day. Because there are essentially 260 operating days per year, the annual frequency for a column rupture is 0.2 per year (260 operating days per year $\times 8 \times 10^{-4}$ per day). This number, although very conservative, was used as the likelihood that precursors exist for these process type accidents. Precursors would include having contaminants in the solutions, degraded resins, etc.

Human Error Probability

Missed Procedural Step. Procedures are used to ensure that the setups are correct and materials introduced into the process meet the specified criteria, such as concentrations for solutions, etc. If one of these steps is omitted, then the initiating event can progress into an accident (e.g., overpressurization of an ion-exchange column). Generally, it takes more

than one step to be missed or improperly done in order for an accident to progress; but, in this case it is assumed that the omission of one step, such as a quality control step for measuring the concentration of feed material, occurs and can contribute to the overpressurization event occurring. The probability for omitting a step in a procedure is generally from 3×10^{-4} to 3×10^{-3} per demand (Mahn et al. 1995). Therefore, the midpoint of 1.7×10^{-3} per demand is used in this analysis.

Missed Procedural Check. Because the setups and the processes are governed by procedures, checks are also made by operations staff to ensure that each step has been followed. The failure of an operations staff member to detect such an omission is 0.1 per demand (Swain and Guttman 1983).

Process Controls

Blocked Output Line. Pressure can bleed out of the ion-exchange column through the output line. However, it has been assumed that this output line, under this condition, can easily become blocked. Therefore, the probability of this line failing to relieve overpressurization is assumed to be 1.0, a very conservative assumption.

Relief Valve Failure. Based on industry experience, the failure rate for relief valves is from 1.4×10^{-5} to 3.6×10^{-5} per demand (NRC 1998, Table III 2-3). Again, the midpoint value of 2.5×10^{-5} was selected for this analysis.

HEPA Filter (Glovebox). The glovebox has a HEPA filter to contain any material that could become aerosolized in the glovebox. Although, the overpressurization and subsequent rupture of a column is not expected to damage the glovebox. This analysis conservatively assumes that the HEPA filter fails, and the probability is set to 1.0

TABLE G.5.6.14-1.—Accident Progression Associated with Either Occurrence Frequency or Failure Rate

SCENARIO PROCESS EVENT AT TA-55	INITIATOR FREQUENCY	HUMAN ERROR PROBABILITY		PROCESS CONTROL FAILURE		BUILDING CONTROL FAILURES	FREQUENCY OF ION-EXCHANGE COLUMN OVER- PRESSURIZATION AND PLUTONIUM RELEASE
		MISSED PROCEDURAL STEP	MISSED PROCEDURAL CHECK	PROBABILITY OF BLOCKED LINE	PROBABILITY OF RELIEF VALVE FAILURE		
Ion-Exchange Column Rupture	0.2/yr	0.0017	0.1	1.0	2.5×10^{-5}	1.0 (glovebox HEPA filter failure)	8.5×10^{-10} /yr (worker hazard only)
Ion-Exchange Column Rupture and Loss of HEPA Filters	0.2/yr	0.0017	0.1	1.0	2.5×10^{-5}	6.3×10^{-7} (HEPA failure/HVAC operating)	5.6×10^{-16} /yr
Ion-Exchange Column Rupture and Loss of Ventilation System	0.2/yr	0.0017	0.1	1.0	2.5×10^{-5}	4.5×10^{-7} (HEPAS operating/HVAC fails)	3.8×10^{-16} /yr

Building Controls

HEPA System. For TA-55, filtration consists of a three-stage HEPA filter system located on the outside of the facility. Any incident inside of the facility, such as an ion-exchange column rupture, would not damage the HEPA filters or the ventilation system. Therefore, for the HEPA filters to fail, at the same time this accident occurs, is an independent event.

LANL data from 1990 to 1994 (LANL 1990b, LANL 1991b, LANL 1994c, LANL 1994d, and LANL 1995h) looked at the failure rates of HEPA filters. When the failure rate of a two-stage HEPA filter system was considered (LANL 1996k), the failure probability for a single HEPA stage was 5 percent. For three stages of filters to fail, the failure probability is 1.3×10^{-4} .

HEPA System Summary

- *1st stage HEPA filter failure: 0.05 per demand*
- *2nd stage HEPA filter failure: 0.05 per demand*
- *3rd stage HEPA filter failure: 0.05 per demand*
- *Monitoring instrumentation failure: 5×10^{-3} per demand*
- *Failure of three-stage HEPA filter system: 6.3×10^{-7} per demand*

However, the HEPA filters on TA-55 are monitored to make sure they are functioning properly. The difference in pressure across the filter banks is monitored. An alarm sounds if the proper pressure drops are not being maintained. Also, the sensor is covered by a preventive maintenance program and administrative procedures. Given these conditions, the probability of the sensor failing is 5×10^{-3} (Mahn et al. 1995).

HEPA System Human Error Probability.

Given that the HEPA systems are monitored and action is required to make sure the HEPA filters are operating properly, it is always possible for operators to fail to respond. The Human Reliability Handbook identifies a basic HEP for these circumstances as 0.025 per demand (Swain and Guttman 1983). A shift supervisory function would also be staffed and would be expected to respond if the operator does not. The HEP for this function is 0.1 (Swain and Guttman 1983). The total HEP for H_{HVAC} is 0.025×0.1 , or 2.5×10^{-3} per demand. If this probability is coupled with the probability that the HEPA filters could fail, the probability that the building would be operating without containment is 1.6×10^{-10} .

Facility Containment. If the ventilation system fails (i.e., the fans fail), during the rupture of the ion-exchange column, the negative pressure is not maintained between the room and the glovebox and between the laboratory and the environment. Under these conditions, the building is said to go into a breathing mode and unfiltered air can be exchanged between the building and the outside air. However, because there is nothing keeping the material airborne or drawing it outdoors, very little material can escape.

Facility Containment

- *Probability of loss of power: 1.5×10^{-4}*
- *Probability of diesel generator failure: 0.03*
- *Common mode beta factor: 0.1*
- *Probability of ventilation system failure: 4.5×10^{-7}*

For the building to go into a breathing mode, the power to the fans would have to fail and the back-up diesel generator would have to fail also. The annual rate for loss of power is 0.04 per year according to the Western Systems Coordination Council (Oswald et al. 1982). A

typical beta factor for common mode failures is 0.1 (Fleming et al. 1985).

Expanded Operations, Reduced Operations, and Greener Alternatives Frequency Analysis

This accident covers the generic operation of TA-55 for process type events. No increase or decrease in the level of activity associated with the accident frequency is anticipated for any of the other alternatives.

No Action Alternative Source and Suspension Term Calculations

Source Term with Operational HEPA and HVAC Systems. Table G.5.6.14-2 summarizes the results of the source term calculations. The derivation of these numbers is described in the following sections.

When the accident occurs, plutonium is either in the form of plutonium nitrate in solution or it has adhered to the column resin. When the column ruptures, the plutonium can be aerosolized either by the flashing of the solution or by the burning of the resin bed. Because these represent two different mechanisms for plutonium release from the ion-column rupture, the two source terms are tracked separately.

Material-at-Risk. For the solution, MAR equals 246 grams in the form of plutonium nitrate. The maximum concentration of the solution is 100 grams per liter. The volume of the column is 2.46 liters; therefore, the MAR is 246 grams of weapons-grade plutonium in solution as plutonium nitrate.

<i>Material-at-Risk</i>
<ul style="list-style-type: none"> • <i>Material Source: Plutonium Nitrate</i> • <i>MAR = 246 g</i> • <i>Material Source: Plutonium Oxide</i> • <i>MAR = 1,000 g</i>

For the column, the maximum capacity of the resin is 1,000 grams of weapons-grade plutonium (LANL 1996k). Although the plutonium on the resin is not in oxide form, the plutonium released during the accident is assumed to be oxidized due to the high temperatures associated with the burning of the column resins. The oxide designation is used here for tracking purposes only.

Damage Ratio. For flashing of the solution, DR is assumed to be 1.0. All the material in the solution is considered to be involved in the accident.

<i>Damage Ratio</i>
<ul style="list-style-type: none"> • <i>Material Source: Plutonium Nitrate</i> • <i>DR = 1.0</i> • <i>Material Source: Plutonium Oxide</i> • <i>DR = 0.1</i>

Although the resins have remained stable under high temperature and exposure to radiation, 10 percent of the resin in the column is assumed to burn or degrade due to the high temperatures. This assumption is a conservative estimate of the material on the column that can be released during the accident.

TABLE G.5.6.14-2.—Source Term with Operational HEPA and HVAC Systems

MATERIAL SOURCE	MAR	DR	ARF	RF	LPF	SOURCE TERM
Plutonium Nitrate	246 g	1.0	0.01	0.6	8 x 10 ⁻⁹	1.2 x 10 ⁻⁸ g
Plutonium Oxide	1,000 g	0.1	0.01	1.0	8 x 10 ⁻⁹	7.2 x 10 ⁻⁹ g

Airborne Release Fraction and Respirable Fraction. For the solution, the bounding values were for a flashing spray from relatively low energy liquids. The liquids had temperatures greater than the boiling point but less than 122°F (50°C) superheat. Therefore, the values for the ARF and RF are 0.01 and 0.6, respectively (DOE 1994d).

Airborne Release Fraction (ARF) and Respirable Fraction (RF)

- *Material Source: Plutonium Nitrate*
— $ARF = 0.01$
— $RF = 0.6$
- *Material Source: Plutonium Oxide*
— $ARF = 0.01$
— $RF = 0.9$

In the TA-55 SAR (LANL 1996k), the product of the ARF x RF is given as 0.009. This product is consistent with the highest measured ARF of 0.0078, with an RF of 0.9, for the burning of contaminated polystyrene and ion-exchange resin (DOE 1994d). Therefore, an ARF x RF of 0.009 was used in this analysis.

Leak Path Factor. For this case, the material escapes into the ventilation system and is filtered through a three-stage HEPA filter. The filtration factor is 8×10^{-9} (LANL1996k).

Suspension Term with Operational HEPA and HVAC Systems. Table G.5.6.14-3 summarizes the results of the suspension term calculations. The amount of suspended material is based on the type of accident and resulting dispersal mechanisms after the accident. For

Leak Path Factor (LPF)

- *Material Source: Plutonium Nitrate*
— $LPF = 8 \times 10^{-9}$
- *Material Source: Plutonium Oxide*
— $LPF = 8 \times 10^{-9}$

this case, the HEPA filters and ventilation systems are assumed to be operational. Each of the terms is explained in the following sections.

Material-at-Risk. Because very little material escapes to the environment, the amount of material assumed to remain at the site for further dispersal is the same as the original MAR.

Material-at-Risk

- *Material Source: Plutonium Nitrate*
— $MAR = 246 \text{ g}$
- *Material Source: Plutonium Oxide*
— $MAR = 1,000 \text{ g}$

Damage Ratio. In both instances, the same fraction of material is considered available for further dispersal as was available for the original accident. All the material in solution is considered available. Plutonium that was not released from the resin bed initially is still not considered available; therefore, the DR is 10 percent, or 0.1.

Airborne Release Rate, Release Period, and Respirable Fraction. For the solution, the suspended material is assumed to come from a liquid on a heterogeneous surface (stainless steel, concrete) exposed to low air speeds up to

TABLE G.5.6.14-3.—Suspension Term with Operational HEPA and HVAC Systems

MATERIAL SOURCE	MAR	DR	ARR	RELEASE PERIOD	RF	LPF	SUSPENSION TERM
Plutonium Nitrate	246 g	1.0	$4 \times 10^{-7}/\text{hr}$	24 hrs	1.0	4×10^{-9}	$1.9 \times 10^{-11} \text{ g}$
Plutonium Oxide	1,000 g	0.1	$4 \times 10^{-5}/\text{hr}$	24 hrs	1.0	4×10^{-9}	$7.7 \times 10^{-10} \text{ g}$

Damage Ratio

- *Material Source: Plutonium Nitrate*
— $DR = 1.0$
- *Material Source: Plutonium Oxide*
— $DR = 0.1$

normal facility ventilation flow (DOE 1994d). These values are bounding values for the type of suspension that could have been considered. Thus, the ARR and RF selected were 4×10^{-7} and 1.0, respectively. Although, the release period is assumed to be 24 hours, this is considered a very conservative value given the limited extent of the accident.

Airborne Release Rate, Release Period, and Respirable Fraction

- *Material Source: Plutonium Nitrate*
— $ARR = 4 \times 10^{-7}$ per hour
— *Release Period = 24 hours*
— $RF = 1.0$
- *Material Source: Plutonium Oxide*
— $ARR = 4 \times 10^{-5}$ per hour
— *Release Period = 24 hours*
— $RF = 1.0$

For the plutonium released from the resin bed, it is assumed that the material was deposited out on material in the glovebox. The values selected for the ARR and RF, 4×10^{-5} and 1.0, were for surface contamination from combustible solids under ambient conditions (DOE 1994d). Again these values along with the release period of 24 hours were bounding given this type of accident.

Leak Path Factor. The HEPA filters and the ventilation system is assumed to be operating after the accident for this scenario. Thus, the filtration efficiency for the three-stage HEPA filters is used in this case, and very little of the material can escape.

Leak Path Factor

- *Material Source: Plutonium Nitrate*
— $LPF = 8 \times 10^{-9}$
- *Material Source: Plutonium Oxide*
— $LPF = 8 \times 10^{-9}$

Source Term with Failed HEPA Filters and Operational HVAC Systems. Table G.5.6.14–4 summarizes the results of the source term calculations. The values are the same for the accident with operational HEPA and HVAC systems, except for LPF. Therefore, only LPF is discussed below.

Leak Path Factor. For this case the HEPA filters are assumed to fail, but the ventilation system is operating. Material is drawn into the ventilation system and released out the south stack of the building. No credit is assumed either for settling or deposition in the ductwork, etc.; therefore, the LPF is 1.0.

Leak Path Factor

- *Material Source: Plutonium Nitrate*
— $LPF = 1.0$
- *Material Source: Plutonium Oxide*
— $LPF = 1.0$

Suspension Term with Failed HEPA Filters and Operational HVAC System. Table G.5.6.14–5 summarizes the results of the suspension term calculations. The material suspended is based on the type of accident and resulting dispersal mechanisms after the accident. For this case, the HEPA filters have failed but the fans are assumed to be operational. These terms are identical to the case where the HEPA filters have not failed, except for MAR and LPF. Therefore, only MAR and LPF are discussed below.

Material-at-Risk. The amount of material remaining at the site is assumed to be the initial

TABLE G.5.6.14-4.—Source Term with Failed HEPA Filters and Operational HVAC Systems

MATERIAL SOURCE	MAR	DR	ARF	RF	LPF	SOURCE TERM
Plutonium Nitrate	246 g	1.0	0.01	0.6	1.0	1.5 g
Plutonium Oxide	1,000 g	0.1	0.01	0.9	1.0	1.0 g

TABLE G.5.6.14-5.—Suspension Term with Failed HEPA Filters and Operational HVAC Systems

MATERIAL SOURCE	MAR	DR	ARR	RELEASE PERIOD	RF	LPF	SUSPENSION TERM
Plutonium Nitrate	244.5 g	1.0	$4 \times 10^{-7}/\text{hr}$	24 hrs	1.0	1.0	0.0023 g
Plutonium Oxide	999.2 g	0.1	$4 \times 10^{-5}/\text{hr}$	24 hrs	0.9	1.0	0.096 g

MAR, minus the amount that was released for atmospheric transport.

Material-at-Risk

- *Material Source: Plutonium Nitrate*
 - MAR = 246 g
 - Dispersed MAR = 1.5 g
 - Suspension MAR = 244.5 g
- *Material Source: Plutonium Oxide*
 - MAR = 1,000 g
 - Dispersed MAR = 0.81 g
 - Suspension MAR = 999.2 g

Leak Path Factor. For this case, the HEPA filters are assumed to fail but the ventilation system is operating. Material is drawn into the ventilation system and released out the south stack of the building. No credit is assumed either for settling or deposition in the ductwork, etc. The LPF is taken as 1.0.

Leak Path Factor

- *Material Source: Plutonium Nitrate*
 - LPF = 1.0
- *Material Source: Plutonium Oxide*
 - LPF = 1.0

Source Term with Failed HVAC Fans and Operational HEPA Filters. Table G.5.6.14–6 summarizes the results of the source term calculations. The accident progression is the same except that, in this case, the HEPA filters remain in tact but the fans, drawing material through the ventilation systems, fail. The only way to get material out of the building is through exchange of air with the atmosphere, such as entering or exiting the building. Thus, the only term that is discussed below is LPF.

Leak Path Factor. This LPF is for a building in a breathing mode, but with a strong temperature difference between the facility and the environment. This value is generally associated with a fire. Although a fire is not part of this

accident progression, the value will be used here as a conservative number.

Leak Path Factor

- *Material Source: Plutonium Nitrate*
 - LPF = 0.011
- *Material Source: Plutonium Oxide*
 - LPF = 0.011

Suspension Term with Failed HVAC Fans and Operational HEPA Filters. Table G.5.6.14–7 summarizes the results of the suspension term calculations. The material suspended is based on the type of accident and resulting dispersal mechanisms after the accident. For this case, the HVAC fans have failed but the HEPA filters remain intact. These terms are identical to the case where the HEPA filters failed, except for LPF. Because so little material is released during the accident, MAR is considered the same as the source term MAR. Therefore, only LPF is discussed below.

Leak Path Factor. The value will be used as a conservative number and is the same LPF used in the determination of the source term.

Leak Path Factor

- *Material Source: Plutonium Nitrate*
 - LPF = 0.011
- *Material Source: Plutonium Oxide*
 - LPF = 0.011

Summary of Source and Suspension Terms. Table G.5.6.14–8 summarizes the amount of material that is available for atmospheric transport. Each case represents a different failure mechanism for the building HEPA filtration systems.

Consequences for Facility Workers. All facility operations personnel receive emergency preparedness training specific to the facility and for procedures applicable to the entire LANL.

TABLE G.5.6.14-6.—Source Term with Failed HVAC Fans and Operational HEPA Filters

MATERIAL SOURCE	MAR	DR	ARF	RF	LPF	SOURCE TERM
Plutonium Nitrate	246 g	1.0	.01	0.6	0.011	0.016
Plutonium Oxide	1,000 g	0.1	0.9	1.0	0.011	0.01

TABLE G.5.6.14-7.—Suspension Term with Failed HVAC Fans and Operational HEPA Filters

MATERIAL SOURCE	MAR	DR	ARR	RELEASE PERIOD	RF	LPF	SUSPENSION TERM
Plutonium Nitrate	246 g	1.0	4×10^{-7} /hr	24 hrs	1.0	0.011	2.6×10^{-5}
Plutonium Oxide	1,000 g	0.1	4×10^{-5} /hr	24 hrs	1.0	0.011	1.1×10^{-3}

TABLE G.5.6.14-8.—Summary of Material Available for Atmospheric Transport

SCENARIO	MATERIAL TYPE	SOURCE TERM	SUSPENSION TERM	TOTAL
Filtration Systems Operating	Plutonium Nitrate	1.2×10^{-8} g	1.9×10^{-11} g	1.2×10^{-8} g
	Plutonium Oxide	7.2×10^{-9} g	7.7×10^{-10} g	8.0×10^{-9} g
Total				2.0×10^{-8} g
HEPAs Failed	Plutonium Nitrate	1.5 g	0.0023 g	1.5 g
	Plutonium Oxide	0.81 g	0.096 g	0.9 g
Total				2.4 g
HVAC Failed	Plutonium Nitrate	0.016 g	2.6×10^{-5} g	0.016 g
	Plutonium Oxide	0.011 g	0.0011 g	0.12 g
Total				0.14 g

The Emergency Action Plan directs personnel to move as quickly as possible away from any hazardous situation and to make appropriate notifications to the EM&R Office as soon as they are safely away from the hazard. Once notified, the EM&R Office assumes all elements of emergency response and coordination.

Breach of the ion-exchange column may include breach of adjacent vessels, breach of the glovebox exhaust filter, and damage to one or more gloves and/or loss of a window in the proximity of the affected column. The dissipation of the pressure surge through the glovebox line and the glovebox ventilation exhaust is such that no damage to the glovebox exhaust filter plenums would occur. If an operations technician is involved in glovebox work at the time of the postulated accident, severe injury is possible. The worker would be exposed to some glass shrapnel (protected, for the most part, by the shielding screen on the column) and to the forcibly ejected nitric acid/plutonium nitrate solution (LANL 1996k).

No fatalities have been associated with ion-exchange resin explosions in nuclear applications. One medical disability resulted from the Hanford cation exchange column incident.

The airborne plutonium concentration in the room will be a function of the volume of gas generated by the column rupture, the degree of mixing in the glovebox, the level of damage to the glovebox, and the resultant volume of gas released to the room. Worker exposure is dependent on worker proximity to a potential glovebox breach and the residence time in the aerosol cloud. If glovebox confinement is breached, the room's continuous air monitor would detect the release of radioactive material to the room and provide both local and TA-55 Operation Center alarm of the incident.

Consequences for the Public. MACCS was used to determine the doses for the integrated

populations. There is only one scenario where the HEPA filters failed and the fans continued to draw material through the ventilation system. Therefore, the atmospheric transport was modeled as an elevated release for both the initial release and the suspension release. Further discussions of atmospheric modeling can be found in section G.2.4.

As a point of comparison, the results of the MACCS runs were ratioed by the amount of material released in the other cases. Thus, the dose of each scenario can be compared (Table G.5.6.14-9).

From these results, no additional excess fatal cancers are anticipated from this event. Any of these results are well within the variations of measuring cancer fatalities within a population group.

The results of the analysis are summarized in Table G.5.6.14-10. No acute fatalities are predicted to result from the postulated accident. The mean collective population dose is projected to total 130 person-rem (TEDE), resulting in 0.063 excess fatal cancers. Mean projected doses for MEIs (and their associated locations) and ground contamination levels are presented in Tables G.5.6.14-11 and G.5.6.14-12. Note that the MEIs are given only for the highest consequence result, but the resultant doses would be lower than those presented.

Deposition Profile. This result is given only for the scenario with the highest consequences. For the other cases the result is expected to be less.

G.5.6.15 *RAD-15, Plutonium Release from Laboratory and Wing Fires at CMR*

General Scenario Description

The accident scenario discussed in RAD-15 is for a general process-initiated fire at the CMR

TABLE G.5.6.14-9.—A Result Comparison of the MACCS Runs

	TOTAL MATERIAL RELEASED	INTEGRATED POPULATION DOSE (PERSON-REM)	EXCESS FATAL CANCERS
Release with Filtration System Operating	2.0×10^{-8} g	1.0×10^{-6}	5×10^{-10}
Release with HEPA Failed	2.4 g	130	0.06
Release with HVAC Failed	0.14 g	7.0	0.0035

TABLE G.5.6.14-10.—Summary Results for RAD-14

ALTERNATIVE	SCENARIO	ACCIDENT FREQUENCY (EVENT/YR)	INTEGRATED POPULATION EXPOSURE (PERSON-REM)	EXCESS FATAL CANCERS
No Action	Release with Operational Filtration System	8.5×10^{-10}	1.0×10^{-6}	5×10^{-10}
	Release with HEPAs Failed	5.6×10^{-16}	130	0.06
	Release with HVAC Failed	3.8×10^{-16}	7.0	0.0035
Expanded Operations	No Change	No Change	No Change	No Change
Reduced Operations	No Change	No Change	No Change	No Change
Greener	No Change	No Change	No Change	No Change

TABLE G.5.6.14-11.—Predicted Mean Doses to MEIs for Scenario RAD-14

MAXIMUM EXPOSED INDIVIDUAL (MEI) DOSE (REM, TEDE)			
MEI LOCATION	OPERATIONAL HEPAs DOSE	DOSE FAILED HEPA	DOSE FAILED HVAC
Closest Public Access: Pajarito Road (50 m)	3.4×10^{-9}	4.1×10^{-1}	0.024
Closest Residence: Royal Crest Trailer Park (900 m)	2.4×10^{-9}	2.9×10^{-1}	0.017
Special Population Distance: Los Alamos Hospital (1,200 m)	1.6×10^{-9}	2.0×10^{-1}	0.012
Special Population Distance: San Ildefonso Pueblo boundary (3,900 m)	2.2×10^{-10}	2.7×10^{-2}	0.0015
Special Population Distance: San Ildefonso Pueblo (17,000 m)	1.4×10^{-11}	1.7×10^{-3}	1.2×10^{-6}

TABLE G.5.6.14–12.—Predicted Mean Ground Contamination Levels for Scenario RAD–14

RADIAL DISTANCE	PLUTONIUM-239 GROUND CONCENTRATION (BQ/m ²)
0.0 to 1.0 km	2.1 x 10 ³
1.0 to 2.0 km	5.8 x 10 ²
2.0 to 3.0 km	2.5 x 10 ²
3.0 to 4.0 km	1.4 x 10 ²
4.0 to 8.0 km	5.7 x 10 ¹
8.0 to 12.0 km	2.1 x 10 ¹
12.0 to 20.0 km	8.4 x 10 ⁰
20.0 to 30.0 km	2.9 x 10 ⁰
30.0 to 40.0 km	1.4 x 10 ⁰
40.0 to 60.0 km	7.1 x 10 ⁻¹
60.0 to 80.0 km	3.8 x 10 ⁻¹

BQ/m² = Becquerel per square meter

Building. The fire is postulated to start in a laboratory that in the future may house a plutonium hydride-dehydride process. A variation of the scenario in which the fire develops into a wing-wide fire is also analyzed.

The plutonium hydride-dehydride process was developed from a small-scale experimental setup located at TA–55–4. This experiment was used to determine the rates of reaction and other physical parameters that were necessary for a feasibility study as well as the design of the hydride-dehydride process. In the future, the process may involve up to 4.5 kilograms of plutonium, and so was selected for analysis.

The fire is assumed to start from any one of a number of possible initiators. The fire is not put out either by personnel in the laboratory with manual fire extinguishers or by the laboratory automatic fire suppression systems. Furthermore, doors to the laboratory are left open allowing aerosolized plutonium to get into

the corridor of the wing. Finally, emergency doors are used by personnel to exit the CMR Building, creating a pathway for aerosolized plutonium to escape the building.

In the future, this hydride-dehydride process may be located at both TA–55–4 and at the CMR Building. This scenario at TA–55–4 is not considered because the dehydride-hydride process itself is not considered a potential fire initiator due to current design features, which are listed in the preconceptual design report (LANL 1996q). Secondly, the fire history at TA–55–4 does not support a general fire scenario, given the defense-in-depth building features (such as fire barriers and HEPA filters), and the process designs (such as process monitoring and limited combustible material).

No Action Alternative Frequency Analysis

The frequencies above are derived in the subsequent subsections.

No Action Alternative Frequency Analysis

- *CMR Scenario: Laboratory Fire*
 - *Fire Frequency* = 4.0×10^{-3}
 - *Plutonium Release Frequency* = 3.6×10^{-5}
- *CMR Scenario: Wing-Wide Fire*
 - *Fire Frequency* = 3.5×10^{-5}
 - *Plutonium Release Frequency* = 3.2×10^{-5}

Fire Initiators

No specific initiator is used for this accident sequence. Instead, fires are taken to occur at a rate of approximately one per year. This frequency is based on a review of the number of CMR incident reports found in the ORPS database. There were three reported fire incidents in the 5 years.

Fire Frequency

Damage to the plutonium is possible only if fire suppression fails. Fire suppression includes actions by personnel in the laboratory as well as automatic fire suppression systems. Therefore, the frequency of a laboratory fire is the product of the frequency of fire incidents and the probability that successive fire suppression systems will fail. If either of these barriers succeed, the result is a fire that does not release radioactive material.

Fire Frequency

- *Frequency of fire incidents at CMR 1 per year*
- *Probability of manual suppression failure: 0.1 per event*
- *Probability of automatic suppression failure: 0.04 per event*
- *Frequency of laboratory fires at CMR 4×10^{-3} per year*

Operating history for industry indicates that about 90 percent of fires are manually extinguished. The same probability for the manual suppression of fires is used for accident analysis at the CMR Building (LANL 1997a). Thus, the second term is given as 0.1. The third term is taken from the probability of failure of the fire suppression system at TA-55 (SNL 1990).

For a wing-wide fire, there must first be a laboratory fire, and then a failure of the laboratory fire barriers. The fire barriers are the walls and doors of the laboratory. The frequency of a wing-wide fire is therefore estimated to be 3.5×10^{-5} per year. If the walls and doors contain the fire, no wing-wide fire occurs.

The fire door is a Type 1 barrier with a failure rate of 0.0074 per demand. The walls are a Type 3 barrier with a failure rate of 0.0012. Because either the door or walls could fail and therefore permit the fire to propagate into the wing, the

Fire Frequency (Wing Wide)

- *Frequency of fire incidents at CMR 1 per year*
- *Probability of manual suppression failure: 0.1 per event*
- *Probability of laboratory automatic suppression failure: 0.04 per event*
- *Probability of laboratory fire barrier failure: 0.0086 per demand*
- *Estimated frequency of wing fires at CMR: 3.5×10^{-5} per year*

sum of these terms, 0.0086, is the probability a fire barrier will fail.

Failure of Containment and Release of Plutonium

Laboratory Fire. For the laboratory fire, in order for a substantial quantity of material to be released to the environment, the material must have a direct exit to the environment. If the material escape path is through the HEPA filters that filter exhaust air from the laboratory, or through those HEPA filters that separately process exhaust air from the wing, the material will be essentially contained on the filters. The failure rate of HEPA filters is approximately 1.3×10^{-5} . Thus, the combination of a fire and HEPA filter failure (3.5×10^{-5} per year \times 1.3×10^{-5}) is not a reasonably foreseeable event.

Other means of allowing material to escape to the environment include creating openings into the laboratory that allow material to escape. For the laboratory fire, this includes leaving doors open or allowing material to escape through openings in the doors. In addition, because the laboratories are contained within the wing, a second opening from the wing to the outside must be created, such as by leaving an emergency exit open. That is, the material must escape a laboratory into the wing, and then escape the wing into the outdoors. The joint probability of a release is illustrated as follows:

Laboratory Fire

- Frequency of laboratory fires at CMR: 0.0004 per year
- Probability of laboratory containment failure: 0.9 per event
- Probability of wing containment failure: 0.1 per event
- Frequency of plutonium release: 3.6×10^{-5} per year

During a laboratory fire, it is considered quite probable that doors would be left open to accommodate personnel exiting the laboratory, or be opened for fire fighting equipment. Thus, the second term is conservatively estimated to be 0.9.

During a laboratory fire, personnel also may use wing emergency exits. The probability that these doors will not close is only 0.01 (LANL 1997a).

Wing Fire. For the wing fire, the frequency of releasing material is the joint frequency of a wing fire and the loss of confinement of material by the wing. This is illustrated as follows:

Wing Fire

- Frequency of wing fires at CMR: 3.5×10^{-5} per year
- Probability of wing containment failure 0.9 per event
- Frequency of plutonium release: 3.2×10^{-5} per year

During a wing-wide fire it is considered quite probable that the confinement for the wing will be lost. Thus, the second term is determined to be 0.9.

Expanded Operations, Reduced Operations, and Greener Alternatives Frequency Analysis. The fire frequencies at the CMR Building remain the same across the alternatives. Due to process design features, the introduction of the hydride-dehydride process does not change the fire frequency at the CMR Building.

Uncertainties and Sensitivities Affecting the Frequency of RAD-15

The initiating fire frequency selected was that of all fires. The fact that these fires require a significant combustible loading to enable small fires to spread to the point of involving an entire laboratory and then a wing is not addressed. It is a recognized policy, enforced in practice and procedures, and addressed in worker training, to keep unnecessary combustibles out of areas where there is plutonium.

No Action Alternative—Initial Source and Suspension Term. Table G.5.6.15-1 summarizes the source term calculations. The derivation of these numbers is described in the following subsections.

The source terms are derived from consideration of the total amount of material that can be involved in a fire. Although fires can involve lesser amounts of material, the risk-dominant scenarios are those that damage

TABLE G.5.6.15-1.—Summary of the Source Term Calculations (No Action Alternative)

SCENARIO	MAR	DR	ARF	RF	LPF	SOURCE TERM
Laboratory Fire	1.0 kg	1.0	0.006	0.01	0.23	0.014 g
Wing Fire	6.0 kg	1.0	0.006	0.01	1.0	0.36 g

the entire laboratory or wing, with its the entire material inventory.

Material-at-Risk. MAR is the administrative limit for material in a laboratory (i.e., 1.0 kilogram of plutonium-239 equivalent). For the wing, the administrative limit is 6.0 kilogram plutonium-239 equivalent.

Material-at-Risk

- *Scenario: Laboratory Fire*
 - $MAR = 1.0 \text{ kg}$
- *Scenario: Wing Fire*
 - $MAR = 6.0 \text{ kg}$

Damage Ratio. The fire is assumed to damage the entire inventory. Therefore, the DR is assumed to be 1.0.

Damage Ratio

- *Scenario: Laboratory Fire*
 - $DR = 1.0$
- *Scenario: Wing Fire*
 - $DR = 1.0$

Airborne Release Fraction and Respirable Fraction. The ARF and RF values are taken from DOE Handbook 3010-94 and are based on material type, its form, and the nature of the challenge. The inventory is considered to be in a dispersible form. The ARF and RF values are selected for powder, even though not all of the material in the CMR Building is in the form of a powder. Other material forms and release mechanisms could be postulated, and some combinations could lead to higher values of ARF and RF. However, there are no controls in place at the facility that would control the inventories of various forms and packaging to be present. Also, evaluations of the plutonium facility fires at the Rocky Flats Plant demonstrated that the major contributor to environmental releases during those events was

the tracking of contamination out of the facility by the firefighters and other responders. Assuming the material to be in powder form results in the maximum amount of material being made available for this release mechanism. For a fire, the recommended ARF and RF values are 0.006 and 0.01, respectively (DOE 1994d).

Airborne Release Fraction and Respirable Fraction

- *Scenario: Laboratory Fire*
 - $ARF = 0.006$
 - $RF = 0.01$
- *Scenario: Wing Fire*
 - $ARF = 0.006$
 - $RF = 0.01$

Leak Path Factor. The laboratory fire does not establish a direct path to the environment. Rather, a laboratory fire that does not propagate to involve the wing has an LPF of 0.23. This is the highest LPF found from complex modeling studies for this facility (LANL 1998a). For the wing-wide fire, loss of containment for the building equates to an LPF of 1.0.

Leak Path Factor

- *Scenario: Laboratory Fire*
 - $LPF = 0.23$
- *Scenario: Wing Fire*
 - $LPF = 1.0$

No Action Alternative—Suspension Term. The suspension term is the amount of material subsequently dispersed from the location of the accident by wind or other disturbances. The amount of material available for suspension is highly dependent on accident response and clean-up activities.

Table G.5.6.15–2 summarizes the suspension term results. It should be noted that if the

TABLE G.5.6.15-2.—Summary of the Suspension Term Calculations (No Action Alternative)

SCENARIO	MAR	DR	ARR	RELEASE PERIOD	RF	LPF	SUSPENSION TERM
Laboratory Fire	1.0 kg	1	0.00004	24	1	4×10^{-9}	3.84×10^{-9} g
Wing Fire	6.0 kg	1	0.00004	24	1	1	5.76 g

building remains intact after a wing fire, or if prompt clean-up activities are implemented, this term will be much smaller and could be near zero.

Material-at-Risk. The material remaining at the site is the initial source terms, minus the amount that was initially dispersed in respirable form. Because so little of the initial MAR is transported away from the site by the fire, the amount that is subject to suspension is the same as the initial MAR.

<i>Material-at-Risk</i>
<ul style="list-style-type: none"> • Scenario: Laboratory Fire <ul style="list-style-type: none"> — Initial MAR = 1.0 kg — Initial Source Term = 0.014 g PE-Ci — Suspension MAR = 1.0 kg • Scenario: Wing Fire <ul style="list-style-type: none"> — Initial MAR = 6.0 kg — Initial Source Term = 0.36 g PE-Ci — Suspension MAR = 6.0 kg

Damage Ratio. For suspension, the amount of material damaged was considered to be the same as the fraction that was damaged in the fire.

<i>Damage Ratio</i>
<ul style="list-style-type: none"> • Scenario: Laboratory Fire <ul style="list-style-type: none"> — DR = 1.0 • Scenario: Wing Fire <ul style="list-style-type: none"> — DR = 1.0

Airborne Release Rate, Release Period, and Respirable Fractions. The ARR and RF

selected correspond to a bed of powder exposed to nominal atmospheric conditions, even though this material may remain indoors away from the wind (DOE 1994d). The release period is conservatively assumed to be 24 hours, but could be shorter depending on when clean-up is begun.

<i>Airborne Release Rate, Release Period, and Respirable Fractions</i>
<ul style="list-style-type: none"> • Scenario: Laboratory Fire <ul style="list-style-type: none"> — ARR = 0.00004 — Release Period = 24 — RF = 1 • Scenario: Wing Fire <ul style="list-style-type: none"> — ARR = 0.00004 — Release Period = 24 — RF = 1

Leak Path Factor. For a laboratory fire, the ventilation and HEPA filters are considered to be functional. The LPF for HEPA filtration, 4×10^{-9} , is therefore used for the laboratory fire. For a wing fire, the large damage assumed for this event is assumed to produce an LPF of 1.0.

<i>Leak Path Factor</i>
<ul style="list-style-type: none"> • Scenario: Laboratory Fire <ul style="list-style-type: none"> — LPF = 4×10^{-9} • Scenario: Wing Fire <ul style="list-style-type: none"> — LPF = 1

Expanded Operations Alternative—Source and Suspension Term Calculations. For the Expanded Operations Alternative, the hydride-dehydride process could be located at either the

CMR Building or TA-55. As noted earlier, the general fire scenario is not reasonably foreseeable for TA-55. Therefore, the laboratory fire is assumed to be located in the CMR Building. The material for the hydride-dehydride process is considered to be in addition to the material already present in a CMR laboratory and wing.

Table G.5.6.15-3 summarizes the results of the source term determination. Each of the terms is derived in the following sections.

Material-at-Risk (Table G.5.6.15-4). The hydride-dehydride process is the continuous processing of plutonium from a solid to a plutonium hydride and then into a plutonium powder. The maximum amount of plutonium hydride estimated to be in the process is 250 grams. This material is represented separately because of its pyrophoric nature. The remainder of the material in the laboratory is the feedstock for the hydride-dehydride process, 4.25 kilograms of plutonium metal (LANL 1997d). Although the CMR Building has an administrative wing limit of 6 kilograms of plutonium-239 equivalent, for the Expanded Operations Alternative, the amount of material associated with the hydride-dehydride process has been added to the amount currently in a CMR wing.

Damage Ratio (Table G.5.6.15-5). Because the fire is assumed to involve the entire laboratory, the damage ratio is 1.0. Because the wing fire is assumed to damage the entire wing, the damage ratio for the material is again assumed to be 1.0.

Airborne Release Fraction and Respirable Fraction (Table G.5.6.15-6). The ARF and RF values from DOE Handbook 3010-94 are 0.01 and 1.0, respectively, for finely divided plutonium hydride (DOE 1994d).

Leak Path Factor (Table G.5.6.15-7). LPF is taken as 0.23 for the laboratory fire and 1.0 for the wing fire (LANL 1998b).

Expanded Operations Alternative—Suspension Term. Table G.5.6.15-8 summarizes the results for the suspension term.

Material-at-Risk (Table G.5.6.15-9). The material available for suspension after the fire is considered the initial MAR, minus the respirable quantity transported off site. In most instances, except for the plutonium hydride, so little is considered to have been transported away that the initial MAR was used for the suspension MAR.

Damage Ratio (Table G.5.6.15-10). Because of the fire scenario, all material was considered to be vulnerable to further dispersal. The damage ratio is therefore 1.0.

Airborne Release Rate, Release Period, and Respirable Fraction (Table G.5.6.15-11). The ARF and RF values are 4×10^{-5} per hour and 1.0 (DOE 1994d). The release period is considered to be 24 hours. Prompt clean-up can reduce this amount considerably.

Leak Path Factor (Table G.5.6.15-12). For a laboratory fire, the ventilation and HEPA filters are considered to be functional. The LPF for HEPA filtration is therefore used for the laboratory fire. For a wing fire, the large damage assumed for this event corresponds to an LPF of 1.0.

Uncertainties and Sensitivities affecting the Source Term for RAD-15. The values calculated above are bounding. The largest uncertainty in the source term is considered to be the assumption of an LPF of 1.0. Such a large LPF may be applicable when the structure has completely failed (i.e., collapsed) or when the structure is intact but the HVAC fans are continuing to run with failed HEPA filters. A running ventilation system will pull air into the building through opened doors. In this conservative analysis, it is assumed that the HVAC system is failed or bypassed, but the structure remains intact.

TABLE G.5.6.15-3.—Summary of the Source Term Calculations (Expanded Operations Alternative)

SCENARIO	MATERIAL TYPE	MAR	DR	ARF	RF	LPF	INITIAL SOURCE TERM
Laboratory Fire	Plutonium Hydride	250 g	1.0	0.01	1.0	0.23	0.575 g
	Plutonium (metal)	4.25 kg	1.0	0.0005	0.5	0.23	0.25 g
Wing Fire	Plutonium Hydride	250 g	1.0	0.01	1.0	1.0	2.5 g
	Plutonium (metal)	4.25 kg	1.0	0.0005	0.5	1.0	1.06 g
	Plutonium-239 equivalent powders, solutions, solids	6.0 kg	1.0	0.006	0.01	1.0	0.36 g

TABLE G.5.6.15-4.—Material-at-Risk (Expanded Operations Alternative)

SCENARIO	MATERIAL TYPE	MAR
Laboratory Fire	Plutonium Hydride	250 g
	Plutonium (metal)	4.25 kg
Wing Fire	Plutonium Hydride	250 g
	Plutonium (metal)	4.25 kg
	Plutonium-239 equivalent powders, solutions, solids	6.0 kg

TABLE G.5.6.15-5.—Damage Ratio (Expanded Operations Alternative)

SCENARIO	MATERIAL TYPE	DR
Laboratory Fire	Plutonium Hydride	1.0
	Plutonium (metal)	1.0
Wing Fire	Plutonium Hydride	1.0
	Plutonium (metal)	1.0
	Plutonium-239 equivalent powders, solutions, solids	1.0

**TABLE G.5.6.15-6.—Airborne Release and Respirable Fraction
(Expanded Operations Alternative)**

SCENARIO	MATERIAL TYPE	ARF	RF
Laboratory Fire	Plutonium Hydride	0.01	1.0
	Plutonium (metal)	0.0005	0.5
Wing Fire	Plutonium Hydride	0.01	1.0
	Plutonium (metal)	0.0005	0.5
	Plutonium-239 equivalent powders, solutions, solids	0.006	0.01

TABLE G.5.6.15-7.—Leak Path Factor (Expanded Operations Alternative)

SCENARIO	MATERIAL TYPE	LPF
Laboratory Fire	Plutonium Hydride	0.23
	Plutonium (metal)	0.23
Wing Fire	Plutonium Hydride	1.0
	Plutonium (metal)	1.0
	Plutonium-239 equivalent powders, solutions, solids	1.0

**TABLE G.5.6.15-8.—Summary of Suspension Term Calculations
(Expanded Operations Alternative)**

SCENARIO	MATERIAL TYPE	MAR	DR	ARR	RELEASE PERIOD	RF	LPF	SUSPENSION SOURCE TERM
Laboratory Fire	Plutonium Hydride	249g	1.0	0.00004	24 hrs	1.0	4×10^{-9}	9.5616e-10 g
	Plutonium (metal)	4.25 kg	1.0	0.00004	24	1.0	4×10^{-9}	1.632e-8 g
Wing Fire	Plutonium Hydride	248 g	1.0	0.00004	24	1.0	1.0	0.24 g
	Plutonium (metal)	4.25 kg	1.0	0.00004	24	1.0	1.0	4.1 g
	Plutonium-239 equivalent powders, solutions, solids	6.0 kg	1.0	0.00004	24	1.0	1.0	5.76 g

TABLE G.5.6.15-9.—Material-at-Risk (Expanded Operations Alternative)

SCENARIO	MATERIAL TYPE	LPF
Laboratory Fire	Plutonium Hydride	249 g
	Plutonium (metal)	4.25 kg
Wing Fire	Plutonium Hydride	248 g
	Plutonium (metal)	4.25 kg
	Plutonium-239 equivalent powders, solutions, solids	6.0 g

TABLE G.5.6.15-10.—Damage Ratio (Expanded Operations Alternative)

SCENARIO	MATERIAL TYPE	DR
Laboratory Fire	Plutonium Hydride	1.0
	Plutonium (metal)	1.0
Wing Fire	Plutonium Hydride	1.0
	Plutonium (metal)	1.0
	Plutonium-239 equivalent powders, solutions, solids	1.0

TABLE G.5.6.15-11.—Airborne Release Rate, Release Period, and Respirable Fraction (Expanded Operations Alternative)

SCENARIO	MATERIAL TYPE	ARR	RELEASE PERIOD	RF
Laboratory Fire	Plutonium Hydride	0.00004	24 hrs	1.0
	Plutonium (metal)	0.00004	24 hrs.	1.0
Wing Fire	Plutonium Hydride	0.00004	24 hrs.	1.0
	Plutonium (metal)	0.00004	24 hrs.	1.0
	Plutonium-239 equivalent powders, solutions, solids	0.00004	24 hrs.	1.0

TABLE G.5.6.15–12.—Leak Path Factor (Expanded Operations Alternative)

SCENARIO	MATERIAL TYPE	LPF
Laboratory Fire	Plutonium Hydride	4×10^{-9}
	Plutonium (metal)	4×10^{-9}
Wing Fire	Plutonium Hydride	1.0
	Plutonium (metal)	1.0
	Plutonium-239 equivalent powders, solutions, solids	1.0

The assumption also was made that one or a few doors would permit aerosolized material to escape. The area of the doors is small relative to the volume of the building, and so there will be a delay during which airborne material will be depositing within the building during its transit between the fire and the release points. This deposition is not accounted for in this analysis. The amount of material available for release also will be reduced by the foam and water used by fire fighting crews who are supposedly leaving doors open. To assume that fire fighters will have open doors requires the sensible assumption that they also will be laying down suppressants that reduce the initial release and will stop all subsequent suspension.

No Action, Expanded Operations, Reduced Operations, and Greener Alternatives Consequences for Facility Workers

Consequences to Workers. From one to three workers may be present in the glovebox operations. These workers could be injured or killed due to direct fire effects in a laboratory fire, or they could be exposed to plutonium oxide particulates by inhalation.

In the case of a wing fire, there may be several dozen workers present in the wing. These workers could be injured or killed due to direct fire effects, or could be exposed to plutonium oxide particulates by inhalation. Workers elsewhere in the building could be exposed to plutonium inhalation and skin contamination.

Because of the long time (decades) for any effects of plutonium inhalation to appear, there would be no deaths from acute doses.

Consequences to the Public. MACCS was used to determine the doses for the integrated populations. The source term was modeled as a 30-minute elevated release. The suspension term was modeled as three, 8-hour, ground level releases. For a discussion of the MACCS code and modeling results, please refer to section G.2.4.

The results of this analysis for a laboratory fire are summarized in Table G.5.6.15–13. No acute fatalities are predicted due to exposure to plutonium. If the fire remains within the laboratory, no excess LCFs are expected from this accident.

The results of this analysis for the wing fire are summarized in Table G.5.6.15–14. The consequences and risk are greater than with the laboratory fire because of the greater inventory of material when the entire wing is considered. If the total wing material is held to 13 pounds (6.0 kilograms), the doses increase slightly when the hydride-dehydride process is introduced because of the pyrophoric nature of the plutonium hydride.

The MEI doses for the Expanded Operations case are given in Table G.5.6.15–15. The MEI doses for the No Action Alternative would be less because the amount of material involved is less.

TABLE G.5.6.15–13.—Summary Results for CMR Laboratory Fire, RAD–15

ALTERNATIVE	ACCIDENT FREQUENCY (EVENT/YR)	INTEGRATED POPULATION DOSE (PERSON-REM)	EXCESS LATENT FATAL CANCERS
No Action	3.6×10^{-5}	4.5	0.0023
Expanded Operations	No Change ^a	175	0.088
Reduced Operations	No Change ^a	No Change ^a	No Change ^a
Greener	No Change ^a	No Change ^a	No Change ^a

^a No change is expected with regard to the No Action Alternative.

TABLE G.5.6.15–14.—Summary Results for the CMR Wing Fire, RAD–15

ALTERNATIVE	ACCIDENT FREQUENCY (EVENT/YR)	INTEGRATED POPULATION DOSE (PERSON-REM)	EXCESS LATENT FATAL CANCERS
No Action	3.2×10^{-5}	1,700	0.85
Expanded Operations	No Change ^a	3,400	1.7
Reduced Operations	No Change ^a	No Change ^a	No Change ^a
Greener	No Change ^a	No Change ^a	No Change ^a

^a No change is expected with regard to the No Action Alternative.

TABLE G.5.6.15–15.—Predicted Mean Doses to MEIs for Scenario RAD–15 (Expanded Operations Alternative)

MAXIMUM EXPOSED INDIVIDUAL (MEI) DOSE (REM, TEDE)		
MEI LOCATION	LABORATORY FIRE	WING FIRE
Closest Public Access (SA): Diamond Road (40 m)	0.41	9.1×10^1
Nearest Residence (CMR SAR): Los Alamos Townsite (1,000 m)	0.48	9.2×10^0
Nearest Special Population Distance: Los Alamos Medical Center (1,100 m)	0.18	3.4×10^0
Other Nearest Residences (CMR SAR): Royal Crest Trailer Park (1,200 m)	0.16	3.0×10^0
Special Population Distance: San Ildefonso Pueblo (4,500 m)	0.02	3.5×10^{-1}
Special Population Distance: San Ildefonso Pueblo (18,600 m)	0.001	2.6×10^{-2}

Note: Approximated as 50 m.

Deposition Profile. The ground contamination levels for the Expanded Operations Alternative are given in Table G.5.6.15–16. The levels for the No Action Alternative would decrease correspondingly to the amount of material released for the No Action Alternative.

After publication of the Draft LANL SWEIS, DOE approved the CMR Basis for Interim Operations (BIO) (LANL 1998b) on August 31, 1998. That document includes a detailed analysis of a similar wing-wide fire. The CMR BIO takes a different approach to the accident, due to its stated need to identify the facility systems, processes, and controls necessary to prevent or mitigate the postulated accidents. The CMR BIO analysis results in a similar frequency, and MEI doses ranging from 10.8 rem to 42.8 rem, depending on the release mechanisms. The CMR BIO also assumes 95 percent meteorological conditions; whereas, the SWEIS uniformly assumed mean conditions. Given the differing assumptions in the scenarios, the large underlying uncertainties in such analyses, and the difference in meteorological modeling, these results demonstrate good agreement. Therefore, both analyses provide similar results to allow for the appropriate decision making.

G.5.6.16 *RAD–16, Plutonium Release Due to Aircraft Crash and Fire at CMR*

General Scenario Description

Accident Scenario RAD–16 involves the crash of an aircraft, accompanied by a fire, at the CMR Building, TA–3–29.

From the analysis of the aircraft operating in the vicinity of the CMR Building (section G.4.1.3), single- and multiple-engine general aviation aircraft and small military aircraft are capable of penetrating into a wing at the CMR Building. A fire then starts due to ignition of the planes fuel

load and damage to a portion of the plutonium inventory in a wing. Because a range of outcomes is possible, the damage to the inventory is assumed to be proportional to the size of the burn area created by the fuel spill.

No Action Alternative Frequency Analysis

The analysis for the frequency of aircraft hitting the CMR Building and causing a release of hazardous material is presented in section G.4.1.3. The frequency for an aircraft penetration and resulting fire for the CMR Building is 3.5×10^{-6} . The aircraft that operate in the vicinity of LANL are predominantly general aviation, either single- or multiple-engine aircraft, with additional small military aircraft that make overflights in the area. These aircraft make up approximately 96 percent of the aircraft that have a greater than 10^{-6} chance per year of hitting and releasing material from the CMR Building.

It should be noted that the area of the CMR Building was reduced from the total building square footage to the combined areas of Wings 3, 5, 7, and 9. Because most of the hazardous materials are located in these areas, the reduction in area was deemed reasonable to account for the frequency of actually involving hazardous material in an aircraft crash induced fire. If the entire building is used for the calculations, the results change modestly (by about a factor of 2).

Expanded Operations, Reduced Operations, and Greener Alternatives Frequency Analysis

The frequency of an aircraft crash does not vary across the alternatives. Because no major changes in the location of hazardous material or their amounts are planned across alternatives, the probability of releasing these materials from an aircraft crash does not change.

TABLE G.5.6.15–16.—Ground Contamination Levels (Expanded Operations Alternative)

RADIAL DISTANCE	PLUTONIUM-239 GROUND CONCENTRATION (BQ/m ²)	
	LABORATORY FIRE	WING FIRE
0.0 to 1.0 km	2.0×10^3	4.0×10^4
1.0 to 2.0 km	3.8×10^2	7.5×10^3
2.0 to 3.0 km	1.9×10^2	3.7×10^3
3.0 to 4.0 km	1.2×10^2	2.2×10^3
4.0 to 8.0 km	4.7×10^1	9.2×10^2
8.0 to 12.0 km	1.9×10^1	3.7×10^2
12.0 to 20.0 km	7.5	1.5×10^2
20.0 to 30.0 km	3.0	5.8×10^1
30.0 to 40.0 km	1.7	3.3×10^1
40.0 to 60.0 km	8.2×10^{-1}	1.6×10^1
60.0 to 80.0 km	4.3×10^{-1}	8.5×10^0

BQ/m² = Becquerel per square meter

Uncertainties and Sensitivities Affecting the Frequency of RAD-16

There is a large number of data required in order to perform the DOE Standard 3014-96 calculations. In addition, the standard itself requires the use of numerous equations that are recognized to be approximations.

No Action Alternative Source and Suspension Term Calculations

Source Term. The source term is derived from consideration of the amount of material that can be involved in a fire and the subsequent amount that, through the dynamics of the accident and a fire, can be made available for atmospheric transport. Because there are several types of aircraft that contribute to the frequency term for an aircraft crash event, the source terms for the three most likely aircraft to impact the CMR Building, are listed in Table G.5.6.16-1.

Determination of the source term follows the standard format, as illustrated in Table G.5.6.16-1. The source term summary presented in this table is explained in subsequent sections.

The source terms are calculated by multiplying together each of the factors in the standard equation. These results represent the magnitude of the releases possible from different categories of aircraft that operate in the vicinity of LANL.

Material-at-Risk. Each wing in the CMR Building is limited to a maximum of

6.0 kilograms of equivalent plutonium-239 (LANL 1997a). The aircraft are assumed to penetrate only one wing. This scenario is based on the ability of aircraft to penetrate structures. This is assessed by determining whether or not dense components (such as an engine shaft, etc.) can penetrate the building. The fuel is conservatively assumed to enter the building through these penetrations. Thus, this scenario is not likely to involve more material than is in one wing of the CMR Building. MAR, regardless of the aircraft category, is considered to be the maximum inventory in a wing.

<i>Material-at-Risk</i>	
<i>Aircraft Category:</i>	
• <i>Single-Engine</i>	— MAR = 6.0 kg Pu-239 (equivalent)
• <i>Multiple-Engine</i>	— MAR = 6.0 kg Pu-239 (equivalent)
• <i>Small Military</i>	— MAR = 6.0 kg Pu-239 (equivalent)

Damage Ratio. DR will be determined by assessing how much of the inventory could be affected by the fire. To do this, a fire is assumed to start from a fuel spill that spreads across a portion of the CMR Building, and subsequently involves the inventory of plutonium in this portion. The Rocky Flats Risk Assessment Guide (RFETS 1994) was used to determine the burn area for the amount of fuel spilled. In this case, the entire fuel load of the appropriate aircraft is assumed to burn. Because the inventories are being used in various

TABLE G.5.6.16-1.—Source Term for Aircraft Crash

AIRCRAFT CATEGORY	MAR ^a	DR	ARF	RF	LPF	SOURCE TERM ^a
Single-Engine	6.0 kg Pu-239	.021	0.006	0.01	1.0	0.008 g Pu-239
Multiple-Engine	6.0 kg Pu-239	.068	0.006	0.01	1.0	0.024 g Pu-239
Small Military	6.0 kg Pu-239	.298	0.006	0.01	1.0	0.11 g Pu-239

^a Pu-239 refers to equivalent plutonium-239.

gloveboxes and laboratories throughout a wing, the inventory is also assumed to be evenly distributed throughout the CMR wing. Thus, the damage ratio for a given aircraft category was determined to be the ratio of the burn area to the total square footage of one wing in the CMR Building.

Damage Ratio

Aircraft Category:

- *Single-Engine*
— $DR = 0.021$
- *Multiple-Engine*
— $DR = 0.068$
- *Small Military*
— $DR = 0.298$

The characteristics of these aircraft categories, as identified in the supporting documentation for DOE Standard 3014-96, were reviewed and the bounding fuel load was selected. The aircraft selected for these categories are: (1) the Piper Turbo line, with a fuel load of 128 gallons (486 liters) for the single-engine piston aircraft; (2) the Cessna Titan line, with a fuel load of 413 gallons (1,564 liters) for the multiple-engine piston aircraft; and (3) the F-16C, with a fuel load of 1,801 gallons (6,819 liters) for the small military aircraft (LLNL 1996). (The F-16C is typical of local military operations out of Kirtland Air Force Base in Albuquerque, New Mexico.)

According to the Rocky Flats Risk Assessment Guide (RFETS 1994), the estimate for burn area is a 250-square-foot (23-square-meter) burn area per 50 gallons (189 liters) of fuel.

The area of a wing, A_{WING} , at the CMR Building is approximately 30,250 square feet (275 feet by 110 feet). The burn areas identified below represent the following percentages of the total square footage for a wing at the CMR Building and therefore represent an equivalent DR for the plutonium inventory in a wing.

Burn Areas

Aircraft Category:

- *Single-Engine*
— $F_{LOAD} = 128 \text{ gal.}$
— $A_{BURN} = 640 \text{ ft}^2$
- *Multiple-Engine*
— $F_{LOAD} = 413 \text{ gal.}$
— $A_{BURN} = 2,065 \text{ ft}^2$
- *Small Military*
— $F_{LOAD} = 2,802 \text{ gal.}$
— $A_{BURN} = 9,005 \text{ ft}^2$

A_{BURN} = Burn area in square feet
 F_{LOAD} = Aircraft fuel load in gallons

Burn Area Square Footage

Aircraft Category:

- *Single-Engine*
— % Total Footage ($A_{BURN}/A_{WING} = 2.1\%$)
— $DR = 0.021$
- *Multiple-Engine*
— % Total Footage ($A_{BURN}/A_{WING} = 6.8\%$)
— $DR = 0.068$
- *Small Military*
— % Total Footage ($A_{BURN}/A_{WING} = 29.8\%$)
— $DR = 0.298$

Airborne Release Fraction and Respirable Fraction. The DOE Handbook on airborne release fractions and respirable fractions, DOE Handbook 3010-94, presents values for ARF and RF based on the type of material, its form, and the nature of the event (e.g., fire, explosions, etc.). The ARF and RF values are selected for plutonium in powder form. These values represent the highest numbers for ARF and RF of the material in the CMR Building even though not all of the material in the CMR Building is in the form of a powder. For a fire, the recommended ARF and RF values are 0.006 and 0.01 (DOE 1994d).

Airborne Release Fraction and Respirable Fraction	
<i>Aircraft Category:</i>	
• <i>Single-Engine</i>	• <i>Small Military</i>
— <i>ARF = 0.006</i>	— <i>ARF = 0.006</i>
— <i>RF = 0.01</i>	— <i>RF = 0.01</i>
• <i>Multiple-Engine</i>	
— <i>ARF = 0.006</i>	
— <i>RF = 0.01</i>	

Leak Path Factor. Due to the nature of an aircraft crash into a building and subsequent fire, no credit is taken for confinement of the material by either the structure or potential accident debris. The material that is in a respirable form can then be transported through the atmosphere. LPF is therefore assumed to be 1.0.

Leak Path Factor	
<i>Aircraft Category:</i>	
• <i>Single-Engine</i>	• <i>Small Military</i>
— <i>LPF = 1.0</i>	— <i>LPF = 1.0</i>
• <i>Multiple-Engine</i>	
— <i>LPF = 1.0</i>	

Suspension Term. The suspension term is derived from consideration of the amount of material that can be further dispersed from the site of the accident by the wind or other disturbances. The amount of material available for suspension is highly dependent on accident

response and clean-up activities. However, due to the nature of an aircraft accident, it is assumed that the material at the site can be released into the atmosphere for the next 24 hours.

Determination of the suspension term follows the standard format, as illustrated in Table G.5.6.16–2. The summary of the suspension term, as presented in this table, is explained in subsequent sections.

The suspension terms are calculated by multiplying each of the factors in the standard equation together. These results represent the magnitude of the suspension releases possible from different categories of airplanes that operate in the vicinity of LANL.

Material-at-Risk. Because so little of the material is released due to the fire, most of the material remains at the site. Therefore, 6.0 kilograms equivalent plutonium-239 is considered the MAR for suspension from the release point.

Material-at-Risk	
<i>Aircraft Category:</i>	
• <i>Single-Engine</i>	— <i>MAR = 6.0 kg Pu-239 (equivalent)</i>
• <i>Multiple-Engine</i>	— <i>MAR = 6.0 kg Pu-239 (equivalent)</i>
• <i>Small Military</i>	— <i>MAR = 6.0 kg Pu-239 (equivalent)</i>

TABLE G.5.6.16–2.—Suspension Term Calculations (No Action Alternative)

AIRCRAFT CATEGORY	MAR ^a	DR	ARR	RELEASE PERIOD	RF	LPF	SUSPENSION TERM ^a
Single-Engine	6.0 kg Pu-239	0.021	4 x 10 ⁻⁶ /hr	24 hrs	1.0	1.0	0.008 g Pu-239
Multiple-Engine	6.0 kg Pu-239	0.068	4 x 10 ⁻⁶ /hr	24 hrs	1.0	1.0	0.024 g Pu-239
Small Military	6.0 kg Pu-239	0.298	4x10 ⁻⁶ /hr	24 hrs	1.0	1.0	0.11 g Pu-239

^a Pu-239 refers to equivalent plutonium-239.

Damage Ratio. The DR is the same as the source term release. Material that was not damaged by the initial event is not considered available for suspension releases.

Damage Ratio

Aircraft Category:

- *Single-Engine*
 - $DR = 0.021$
- *Small Military*
 - $DR = 0.298$
- *Multiple-Engine*
 - $DR = 0.068$

Airborne Release Rate, Release Period, and Respirable Fractions. For the fire release, the appropriate ARR and RF values are 4.0×10^{-6} per hour and 1.0, respectively, because it is assumed that the source powder would be buried under some structural debris (DOE 1994d). The suspension is assumed to occur for 24 hours after the initial accident.

Airborne Release Rate, Release Period, and Respirable Fraction

Aircraft Category:

- *Single-Engine*
 - $ARR = 4 \times 10^{-6}$ per hour
 - *Release Period* = 24 hours
 - $RF = 1.0$
- *Multiple-Engine*
 - $ARR = 4 \times 10^{-6}$ per hour
 - *Release Period* = 24 hours
 - $RF = 1.0$
- *Small Military*
 - $ARR = 4 \times 10^{-6}$ per hour
 - *Release Period* = 24 hours
 - $RF = 1.0$

Leak Path Factor. Because the material is exposed to ambient conditions, LPF was considered to be 1.0. ARR accounts for any protection of the material by the debris at the site.

Leak Path Factor

Aircraft Category:

- *Single-Engine*
 - $LPF = 1.0$
- *Small Military*
 - $LPF = 1.0$
- *Multiple-Engine*
 - $LPF = 1.0$

Uncertainties and Sensitivities Affecting the Source Term for RAD-16

The suspension source term calculation extends for 24 hours. This is very conservative in that it is likely that fire fighting and HAZMAT response to the crash scene would be accompanied by extensive use of water and foam-based suppression systems. This application of suppressants would likely continue for some time to preclude flareup of the fire once it is extinguished, as well as precisely to limit further spread of plutonium contamination.

Expanded Operations, Reduced Operations, and Greener Alternatives Source and Suspension Term Analysis

The source and suspension terms do not vary across the alternatives. Because no major changes in the location of hazardous material or their amounts are planned across alternatives, the source and suspension terms do not change. The amount of material that could be involved in the accident varies and has been conservatively estimated based on the wing limits for the facility. These wing limits do not change across alternatives.

Consequences for Facility Workers

An aircraft crash is capable of killing or injuring a large fraction of the worker population in the impacted wing due to generation of missiles, structural damage, fire, etc. Workers in the CMR Building who are not directly affected by

the crash and explosion or fire may be exposed to radiation as a result of plutonium inhalation.

Consequences for the Public

To determine the consequences, or dose, to the public, an average value was used, based on frequency weighting the source and suspension terms for each aircraft category. The total source term used for dose and excess LCF calculations is 0.69 equivalent plutonium-239 (Table G.5.6.16–3). The total suspension term is 0.21 PE-Ci (Table G.5.6.16–4).

MACCS was used to determine the doses for the integrated populations. The source term was modeled as a 30-minute elevated release. The suspension term was modeled as three, 8-hour, ground level releases. For a discussion of the MACCS code and modeling results, please refer to section G.2.4.

The results for this accident are summarized in Table G.5.6.16–5. The accident may result in fatalities to occupant(s) of the aircraft and to people on the ground. However, no acute fatalities from the release of plutonium are predicted to result from the postulated accident. The mean collective population dose is projected to total 56 person-rem (TEDE), resulting in 0.03 excess LCFs. Mean projected doses for MEIs (and their associated locations) and ground contamination levels are presented in Tables G.5.6.16–6 and G.5.6.16–7, respectively.

G.5.7 Facility Hazard Accidents

G.5.7.1 *WORK-01, Inadvertent High Explosives Detonation*

General Description of High Explosives Operations

High explosives (HE) processing facilities are located at LANL TA–8, TA–9, TA–11, TA–16, TA–28, and TA–37. HE processing activities

include storage, synthesis, formulation, pressing, machining, assembly, quality assurance processes, shipping and receiving of HE and HE devices, and disposal. Los Alamos HE facilities were designed in accordance with U.S. Department of Defense (DoD) Ammunition and Explosives Safety Standards, DoD 6055.9 (now referenced in the DOE Explosives Safety Manual [DOE 1994g]). Processing equipment has been continually upgraded and modernized.

HE processing facilities are generally separated from other operations and are all within restricted areas that require DOE badges for access through security check stations. Access to all buildings is further controlled by locks on building entrances that require specially controlled keys. Additionally, all HE areas are patrolled by protective force guards.

Operational controls and the associated level of protection are based on the explosive hazard class. There are four hazard classes. Hazard Class I processes involve activities that are considered to have a high accident potential and are designed to be conducted remotely so that an accidental detonation vents the high pressure and fragments via a frangible wall away from inhabited areas. Examples of Class I activities include screening, blending, pressing, dry machining, and new explosives development. Hazard Class II activities involve a moderate accident potential; examples include weighing, some wet machining, assembly and disassembly, and environmental testing. Hazard Class III activities are designated as having a low accident potential and include storage activities and operations incidental to storage. Hazard Class IV consists of activities involving insensitive HE. This explosive type is so insensitive that a negligible probability exists for accidental initiation or transition from burning to detonation. Selected activities using insensitive HE, such as machining and pressing, are conservatively designated as Class I. Explosives and personnel limits and controls are used to minimize the quantity of explosives and

TABLE G.5.6.16-3.—Frequency Weighted Source Term Calculation for Fire Source Term

AIRCRAFT TYPE	FRACTIONAL CONTRIBUTION TO PERFORATION/FIRE FREQUENCY	INITIAL SOURCE TERM (GRAMS EQUIVALENT PLUTONIUM-239)	WEIGHTED INITIAL SOURCE TERM GRAMS EQUIVALENT PLUTONIUM-239
Single-Engine Piston	0.77	0.008	0.0616
Multiple-Engine Piston	0.16	0.024	0.0038
Small Military	0.031	0.11	0.0034
TOTAL	0.961		0.69

TABLE G.5.6.16-4.—Frequency Weighted Source Term Calculation for Fire Suspension Term

AIRCRAFT TYPE	FRACTIONAL CONTRIBUTION TO PERFORATION/FIRE FREQUENCY	INITIAL SOURCE TERM (GRAMS EQUIVALENT PLUTONIUM-Ci)	WEIGHTED INITIAL SOURCE TERM GRAMS EQUIVALENT PLUTONIUM-239
Single-Engine Piston	0.77	0.012	0.00924
Multiple-Engine Piston	0.16	0.039	0.00624
Small Military	0.031	0.17	0.00527
TOTAL	0.961		0.21

TABLE G.5.6.16-5.—Summary Results for Scenario RAD-16

ALTERNATIVE	ACCIDENT FREQUENCY (EVENT/YR)	INTEGRATED POPULATION EXPOSURE (PERSON-REM)	EXCESS FATAL CANCERS
No Action	3.5×10^{-6}	56	0.03
Expanded Operations	3.5×10^{-6}	No Change	No Change
Reduced Operations	3.5×10^{-6}	No Change	No Change
Greener	3.5×10^{-6}	No Change	No Change

Note: No change is expected with regard to the No Action Alternative.

TABLE G.5.6.16-6.—Predicted Mean Doses to MEIs for Scenario RAD-16

MAXIMALLY EXPOSED INDIVIDUAL (MEI) DOSE (REM, TEDE)	
MEI LOCATION	DOSE
Closest Public Access (SA): Diamond Road (40 m)	3.0
Nearest Residence (CMR SAR): Los Alamos Townsite (1,000 m)	3.4×10^{-2}
Nearest Special Population Distance: Los Alamos Medical Center (1,100 m)	2.8×10^{-2}
Other Nearest Residences (CMR SAR): Royal Crest Trailer Park (1,200 m)	2.4×10^{-2}
Special Population Distance: San Ildefonso Pueblo (4,500 m)	4.1×10^{-3}
Special Population Distance: San Ildefonso Pueblo (18,600 m)	8.4×10^{-4}

TABLE G.5.6.16-7.—Predicted Mean Ground Contamination Levels

RADIAL DISTANCE	PLUTONIUM-239 GROUND CONCENTRATION (BQ/m²)
0.0 to 1.0 km	5.0×10^2
1.0 to 2.0 km	5.8×10^1
2.0 to 3.0 km	2.6×10^1
3.0 to 4.0 km	1.9×10^1
4.0 to 8.0 km	1.5×10^1
8.0 to 12.0 km	1.1×10^1
12.0 to 20.0 km	6.1×10^0
20.0 to 30.0 km	2.6×10^0
30.0 to 40.0 km	1.3×10^0
40.0 to 60.0 km	7.3×10^{-1}
60.0 to 80.0 km	4.1×10^{-1}

BQ/m² = Becquerel per square meter

the number of personnel to carry out an operation in a safe and efficient manner. Personnel may not work alone performing explosives activities that have a high risk of serious injury. Additionally, quantity-separation distance criteria are used to minimize collateral damage in the event of an accident.

General Scenario Description

Accident scenario WORK-01 involves the inadvertent detonation of HE material. Potential accidents involving hazardous or radioactive material are not considered, as their impacts are bounded by the chemical and radiological specific accidents, which have been already analyzed. Based on the foregoing operations/controls discussion, it is very unlikely that an accident would impact workers other than those directly involved in the explosives activity, and it would be extremely unlikely that any credible postulated event would involve the public. The number of individuals that may be injured or fatally harmed for a postulated event will vary depending on the quantity of explosives involved and the number of workers present. As discussed above, operational controls limit both parameters. Laboratory testing of small samples may involve only one worker, while assembly operations (e.g., TA-16-411) may vary from three to ten workers. Blast effects to individuals are summarized in Table G.5.7.1-1 and are taken from the tri-service manual on *Structures to Resist the Effects of Accidental Explosions* (U.S. Army et al. 1990). Generally, human tolerance to the blast output of an explosion is relatively high, with specific impacts dependent on the orientation of the individual to the blast front and the shape of the pressure front (fast or slow rise, stepped loading). The lungs are considered the critical target organ in blast pressure injuries. Considering the high level of human tolerance to blasts and fragment operational/design controls, it is more likely that a postulated explosive accident will result in worker injuries rather than fatalities.

No Action Alternative Frequency Analysis

Walkdowns of selected HE processing facilities and discussions with knowledgeable facility personnel did not identify the occurrence of any explosive blast accidents at LANL resulting in injuries or fatalities. Additionally, a search of 5 years of LANL occurrence report data (1990 through 1994 Type F Reports) did not identify any explosive blast accidents. Site-specific experience at Pantex results in an explosive accident frequency of 10^{-2} per year (DOE 1996a). Based on this DOE system experience and scaling for the level of worker activities (2,000 weapons operations annually at Pantex), an accident frequency range of 10^{-3} to 10^{-2} is estimated for the LANL No Action Alternative.

Expanded Operations Alternative Frequency Analysis

The level of HE operations activity compared to the No Action Alternative is projected to increase: (1) by 40 to 100 percent for fabrication activities, depending on the specific program supported; (2) by 50 percent for HE

TABLE G.5.7.1-1.—Blast Effects to Humans Due to Fast-Rising Air Blasts (3 to 5 Minutes Duration)

CRITICAL ORGAN OR EVENT	MAXIMUM EFFECTIVE PRESSURE (PSI)
Eardrum Rupture:	
Threshold	5
50 percent	15
Lung Damage:	
Threshold	30 to 40
50 percent	80 and above
Lethality:	
Threshold	100 to 120
50 percent	130 to 180
Near 100 percent	200 to 250

Note: Maximum effective pressure is the highest of incident pressure, incident pressure plus dynamic pressure, or reflected pressure.

waste treatment, QA efforts, and receiving, transportation, and storage; (3) by 40 percent for facility support functions; (4) by 25 percent for safety and mechanical testing; and (5) by undefined increases in the remaining capability areas (LANL 1996b). As a first order estimate, it is assumed that the overall increase in the level of HE operations corresponds to the projected increase in HE receiving, transportation, and storage activities. This is based on the observation that receiving, transportation, and storage operations would be expected to reflect the site-wide level of activities in support of HE operations. Consequently, HE handling and processing activities are projected to increase by 50 percent over the No Action Alternative level of effort. This level of change in operations is within the range of past operational activity levels. Consequently, it is concluded that past operational experience and the projected accident frequency for the No Action Alternative would be applicable.

Reduced Operations Alternative Frequency Analysis

The level of HE operations activity is projected to be decreased: (1) to 80 percent of the No Action Alternative level of effort for the safety/mechanical testing and quality assurance efforts; (2) to 75 percent of the No Action Alternative level of effort for test device assembly, stockpile surveillance, and above ground testing; (3) to 60 percent of the No Action Alternative level of effort for HE synthesis and production, HE and plastics development and characterization, HE receiving, transportation and storage, and facility support; (4) to 40 percent of the No Action Alternative level of effort for HE waste treatment; and (5) to a much reduced level of effort for fabrication in support of refurbishment and weapons research and development (LANL 1996b). As a first order estimate, it is assumed that the overall decrease in the level of HE operations corresponds to the projected decrease in HE receiving,

transportation, and storage activities. This is based on the observation that receiving, transportation, and storage operations would be expected to reflect the site-wide level of activities in support of HE operations. Consequently, HE handling and processing activities are projected to decrease to 60 percent of the No Action Alternative level of effort. This level of variation is within the range of past operational activity levels. Consequently, it is concluded that past operational experience would be applicable and that the projected accident frequency would be at the low end of the range for the No Action Alternative.

Greener Alternative Frequency Analysis

The level of HE operations activity for each of the capability categories is projected to be comparable to the Reduced Operations Alternative (LANL 1996b). Consequently, as with the Reduced Operations Alternative, HE handling and processing activities are projected to decrease to 60 percent of the No Action Alternative level of effort, with a projected accident frequency at the low end of the range for the No Action Alternative.

Source Term Calculations

The postulated accident does not release hazardous or radiological material to the environment. Potential HE incidents involving either hazardous or radiological materials are bounded by accident scenarios CHEM-01 through CHEM-06 and RAD-01 through RAD-16.

Uncertainties and Sensitivities Affecting the Source Term for WORK-01

The potential for blast impacts beyond laboratory and operations personnel are extremely low, based on both LANL and DOE system-wide experience and controls.

Consequences of WORK–01 for Facility Workers and the Public

This accident is limited to facility workers. Access controls and operational boundaries preclude any significant impacts to members of the public. Table G.5.7.1–2 summarizes the analysis results for WORK–01.

G.5.7.2 WORK–02, Biohazard Contamination of a Single Worker

General Scenario Description

There are three scenarios in which a LANL worker could be exposed to a biohazard: (1) accidental exposure to a passive or active bacterium, fungus, virus, etc, being used in the HRL (TA–43) for research purposes; (2) contact with fecal material or other infected avian or mammalian bodily fluids during field research or monitoring and surveillance activities; or (3) exposure of health workers to infectious agents carried by workers visiting the clinic. Of these three potential exposures, the one with the highest probability is the accidental exposure during research and development activities involving biohazards in HRL.

The accident scenario WORK–02 involves the inadvertent biohazard contamination of a single worker during activities at TA–43–1 (HRL). Biohazards are present or will be present at TA–43 in passive or active states in some research and development activities.

Biohazards may include facultative pathogens or obligate pathogens such as Clostridium, Pseudomonas, E. coli, saccharomyces, Bacillus, and (in the Expanded Operations Alternative) Hepatitis B.

Activities involving biohazards are conducted, monitored, and regulated by the LANL Institutional Biosafety Committee using guidelines from the National Institutes of Health (NIH) and the Centers for Disease Control and Prevention (CDC). This work is done according to Biohazard Level 2 controls; all waste materials from culture operations are treated to kill the infectious agents prior to disposal, using autoclave heating or viricides/bactericides. Biohazard Level 2 equipment and engineering controls include limited access to work areas, protective laboratory coats and gloves, and safety cabinets or isolation enclosures for any operations that have a high potential for creating aerosols containing microorganisms (LANL 1996b).

Due to the proximity of HRL to the Los Alamos County Medical Center, stringent administrative controls are used to control organisms and potentially contaminated biohazardous waste and research materials. Specific bacteria, such as spore formers, which can live in encysted state for periods of time without nourishment or water or air, can only be used after LANL senior management review, and special protocols are required. Work with live viral agents is prohibited except for engineered viral agents used as vectors for transferring genetic material which present

TABLE G.5.7.1–2.—Summary Results for Scenario WORK–01

ALTERNATIVE	ACCIDENT FREQUENCY	SOURCE TERM
No Action	0.001 to 0.01	Accidental injury or fatality from 1 to 15 operations personnel
Expanded Operations	0.001 to 0.01	Accidental injury or fatality from 1 to 15 operations personnel
Reduced Operations	0.001 to 0.01	Accidental injury or fatality from 1 to 15 operations personnel
Greener	0.001 to 0.01	Accidental injury or fatality from 1 to 15 operations personnel

negligible risk of infection. Research on HIV and other human pathogens is limited to genome mapping and other operations that do not involve the original or active biological material (LANL 1996b).

No Action Alternative Frequency Analysis

In contrast to the documented occurrence of laboratory-acquired infections in laboratory personnel, laboratories working with infectious agents have not been shown to represent a threat to the community (CDC 1993). The primary risks from microbiology laboratories are to laboratory workers, and are specific to the agent, for example (CDC 1993):

- *Hepatitis B*—accidental inoculation, exposure of broken skin or the mucous membranes of the eyes, nose, or mouth
- *Clostridium botulinum*—accidental inoculation; toxin may be absorbed after ingestion or following contact with the skin, eyes, or mucous membranes
- *Pseudomonas*—aerosol and skin exposure

The frequency of accidental infections from biohazards is judged by DOE to be no greater than 0.01 to 0.1 per year given the level of research and development activities. The potential for nonworker exposure is at least hundreds of times less than worker exposure probability and is not credible within the scope of this analysis at a probability of 10^{-6} per year.

Expanded Operations, Reduced Operations, and Greener Alternatives Frequency Analysis

No significant differences in activity levels are identified that would result in a greater risk of accidental infection compared with the No Action Alternative.

Uncertainties and Sensitivities Affecting the Frequency of WORK-02

Hepatitis B is a new potential source of infection in the Expanded Operations Alternative. However, no cases of infection to laboratory workers from any agent were reported in the review of laboratory accidents and incidents in the 1990's or in during several discussions with LANL personnel at TA-43 and the institutional biosafety committee. Accordingly, given the period of time in which TA-43-1 has operated and during which field operations have been conducted, the frequency estimate of 0.01 to 0.1 per year is considered to bound the actual frequency. This frequency is very conservative based on National Cancer Institute (NCI) and NIH statistics of research and development accidental biohazard infection and resulting infection during the 1990's, which would estimate the frequency not to exceed 0.001 (NIH 1996).

Source Term Calculations

This accident does not release hazardous material to the environment. The potential for infection of persons other than laboratory personnel is very low. Because any such infections would have to be first observed in laboratory personnel, the risks are dominated by these original infections. Infection of one laboratory worker is the most likely outcome, multiple worker infections are less likely, and the spread of an infection beyond laboratory or field operations personnel is incredible (less than 10^{-6}).

Uncertainties and Sensitivities Affecting the Source Term for WORK-02

The potential for exposures beyond laboratory personnel are very low, based on both LANL and industry-wide experience.

Consequences of WORK-02 for Facility Workers and the Public

This accident affects only laboratory research and development workers. The potential for public impact is judged to be nil. Table G.5.7.2-1 summarizes the analysis results for WORK-02.

G.5.7.3 WORK-03, Inadvertent Nuclear Criticality Event

General Scenario Description

WORK-03 involves an inadvertent criticality event, the most significant impacts of which are on workers in the immediate vicinity of the event (due to neutron and gamma exposure). Critical assemblies and experiments are routinely performed at Pajarito Site (TA-18), and were considered in RAD-03. Outside of TA-18, a criticality event, although unlikely in the absolute sense, is most likely to occur at TA-55-4 (Plutonium Facility). At this facility, the consideration would mainly be due to operations with fissile material in liquid solutions. While fissile material is handled in the solid form, it is considered to be much less likely to be involved in a criticality event than a solution (LANL 1996k).

Criticality events are capable of producing potentially lethal amounts of neutron and gamma radiation in a localized area. Depending

upon the physical form of the system, such as a solution, the event may be accompanied by the release of plutonium through the aerosolization of the solution and also may produce fission products that might be released to the environment.

Historical Criticality Events

There have been several inadvertent criticality events with solutions since the 1940's. Some of these events are summarized in Table G.5.7.3-1. As demonstrated by the table, these events occur infrequently, and each tends to be unique in nature, making a quantitative frequency estimation difficult. Most recently, there were two criticality events reported in Russia. The first was reported to be an excursion in a uranium solution in May 1997. Later, in June of the same year, a fatality was reported from a criticality event; however, this one apparently involved a solid fueled critical assembly. Details on these two accidents are not sufficient at this time to provide further discussion of them and their potential implications here.

LANL SAR Evaluations of Inadvertent Criticality Event

The TA-55 SAR identifies a nuclear criticality event in the uranium/plutonium separations process as a bounding event. The evaluation is essentially generic, applying to all deep-well,

TABLE G.5.7.2-1.—Summary Results for Scenario WORK-02

ALTERNATIVE	ACCIDENT FREQUENCY	SOURCE TERM
No Action	0.01 to 0.1	Accidental exposure of one laboratory worker resulting in diagnosed infection. No public impact.
Expanded Operations	0.01 to 0.1	Accidental exposure of one laboratory worker resulting in diagnosed infection. No public impact.
Reduced Operations	0.01 to 0.1	Accidental exposure of one laboratory worker resulting in diagnosed infection. No public impact.
Greener	0.01 to 0.1	Accidental exposure of one laboratory worker resulting in diagnosed infection. No public impact.

**TABLE G.5.7.3-1.—Summary of Inadvertent Solution Criticality Events
(1945 to the Present)**

DATE	LOCATION	FISSIONABLE MATERIAL	PHYSICAL ARRANGEMENT	TOTAL FISSION YIELD	DESCRIPTION AND CONSEQUENCES
53/03/15	Mayak, Urals (Russia)	Plutonium solution (31 l)	Steel vessel	2.5×10^{17}	Human error (chief operator transferred solutions from two vessels into a single vessel); chief received 1,000 rad and another operator received 100 rad
54/05/26	Oak Ridge	Uranium solution (18.3 kg Uranium-235, 55.4 l of solution)	Cylindrical annulus, unreflected	1×10^{17}	Shift of poison; no physical damage
56/02/01	Oak Ridge	Uranium solution (27.7 kg Uranium-235, 58.9 l of solution)	Cylinder, unreflected	1.6×10^{17}	Geometry change; warping of bottom of cylinder
57/04/12	Mayak, Urals (Russia)	Uranium solution	Cylinder	2×10^{17}	Human error (leading to oxalate precipitation); lethal to operator, five others developed symptoms of radiation sickness
58/01/02	Mayak, Urals (Russia)	Uranium solution	Tank with control rod	2.3×10^{17}	Human error (staff decided to tip tank to speed up draining of solution, in violation of procedures), bodies acted as reflector; 3 deaths, fourth operator developed radiation sickness and lost sight
58/06/16	Oak Ridge	Uranium solution (2.5 kg Uranium-235, 56 l of solution)	Cylinder, concrete reflected below	1×10^{16}	Valve leaked or left open; no physical damage; \$1,000 loss
58/12/30	Los Alamos	Plutonium solution (3.27 kg Plutonium, 168 l of solution)	Cylinder, water reflected below	1.5×10^{17}	Human error (failure to follow procedure); lethal to operator; no physical damage
59/10/16	Idaho Falls	Uranium solution (34.5 kg Uranium-235, 800 l of solution)	Cylinder, concrete reflected below	1×10^{17}	Spurge gage plugged; no physical damage; \$62,000 loss

**TABLE G.5.7.3-1.—Summary of Inadvertent Solution Criticality Events
(1945 to the Present)-Continued**

DATE	LOCATION	FISSIONABLE MATERIAL	PHYSICAL ARRANGEMENT	TOTAL FISSION YIELD	DESCRIPTION AND CONSEQUENCES
60/12/05	Mayak, Urals (Russia)	Plutonium solution	Cylinder, unfavorable geometry	1×10^{17}	Human error (failure to check results after mass discrepancy discovered; transfer of solution to unfavorable geometry); several people exposed to up to 5 rad
61/01/25	Idaho Falls	Uranium solution (8 kg Uranium-235, 40 l of solution)	Cylinder	6×10^{17}	Human error (instruction misinterpreted); no physical damage; \$1,000 loss
61/08/14	Siberian Chemical Combine (Russia)	Uranium hexafluoride accumulated in oil	Cylinder	1×10^{16}	Human error (assumed first criticality alarm was false, restarted facility); operator received 200 rad
62/09/07	Mayak, Urals (Russia)	Plutonium solution, dissolution of Plutonium scrap in nitric acid; 1.2 kg Plutonium	Cylinder	2×10^{17}	Settling of solution after stirrer turned off; doses low due to no one near dissolver and lead shielding on dissolver
63/01/30	Siberian Chemical Combine (Russia)	Uranium solution	Cylinder	7.9×10^{17}	Human error (poor record keeping, mislabeling of uranium concentration); four persons received 6 to 17 rad at a distance of 10 meters
63/12/13	Siberian Chemical Combine (Russia)	Uranium solution	Cylinder, hemispherical bottom	2×10^{17}	Accumulation of uranium solution in trap; no injuries
64/07/24	Wood River Junction	Uranium solution (2.64 kg Uranium-235)	Cylinder, unreflected	1.1×10^{17}	Human error (failure to follow procedure); lethal to operator; no physical damage
65/12/16	Mayak, Urals (Russia)	Uranium solution	Cylinder	7×10^{17}	Human error (excess loading of uranium into solution, cessation of stirring); several staff exposed up to 30 mR
70/08/24	Windscale (U.K.)	Plutonium complex (2.5 kg Plutonium, 100 l of solution)	Cylinder	1×10^{15}	Plutonium accumulated in organic; no physical damage

Source: DOE 1994b unless otherwise noted.

wet chemistry operations. The accident assumes that as a result of multiple overbatching errors, the fissile material inventory for a glovebox substantially exceeds the allowable limit. A vessel overpressure or some other mechanism results in the rupture of adjacent vessels containing rich solution. The solution collects in a deep well, followed by a separate influx of water (failure of a water line), resulting in a single-pulse solution criticality event yielding 5×10^{17} fissions. The resulting fission products and plutonium aerosol are processed through the ventilation system and released from the south exhaust stack (LANL 1996k). Based on a PRA, the TA-55 SAR estimates the frequency of a solution criticality event at 6×10^{-7} per year per operation (LANL 1996k). Because there are hundreds of operations, the cumulative frequency of a criticality accident in TA-55-4 is estimated to be in the range from 10^{-6} to 10^{-4} per year (LANL 1996k).

The TA-55-4 SAR includes exposure analyses for the maximum off-site individual (MOI) at Royal Crest Trailer Park, 2,952 feet (900 meters) away, for an unmitigated scenario (no HEPA filtration, LPF = 1) and for a realistic scenario (with HEPA filtration). The unmitigated MOI dose is 1.6 rem; whereas, the realistic MOI dose is 35 millirem. Regarding consequences to workers, the SAR states that anyone within 16 feet (4.9 meters) of the criticality location would receive more than 500 rem. The dose at 33 feet (10 meters) drops to 80 rem. The number of people in the room varies with the work being done, but is most likely to be two or three people (LANL 1996k).

No Action Alternative Frequency Analysis

Consistent with the TA-55 SAR analyses, which account for LANL-specific design and operational practices, the frequency of an accidental critical excursion is estimated to be no greater than 10^{-6} per operation; but, considering that there are hundreds of operations per year, the frequency of accidental

criticality is likely to be in the range of 10^{-6} to 10^{-4} per year.

Expanded Operations, Reduced Operations, and Greener Alternatives Frequency Analysis

Although there is an increase in activities involving fissile materials in the Expanded Operations Alternative (as a result of pit production), most of these activities involve solid systems that do not contribute significantly to criticality accident frequency. Other alternatives do not vary significantly in the level of activities that are most likely to give rise to inadvertent criticality events. Accordingly, no difference in frequency is identified across the alternatives.

Uncertainties and Sensitivities Affecting the Frequency of WORK-03

Historical experience has demonstrated that criticality accidents are unpredictable, unique events that do not lend themselves to a straightforward frequency determination. Accordingly, this analysis only attempts to establish a range, rather than an individual value, for the frequency.

Source Term Calculations

Given the low MOI exposure estimates in the TA-55-4 SAR (doses to the MOI of less than 50 millirem), no public exposure estimates will be performed for this accident because it would screen as insignificant based on the SWEIS accident analysis screening methods (off-site exposure of less than 500 millirem).

Consequences of WORK-03 for Facility Workers and the Public

The consequences to the public from WORK-03 are insignificant. Workers located close to the site of the criticality event (i.e., within 30 feet [9.2 meters]) can receive doses of neutron and gamma radiation on the order of

500 rem or higher. Acute radiation injuries and deaths are possible within this radius. Workers located elsewhere in the facility could be exposed to volatile fission products (noble gases, radioiodines, etc.) that evolve from the solution criticality accidents. This is the same for all options. Table G.5.7.3–2 summarizes the analysis results for WORK–03.

G.5.7.4 WORK–04, Inadvertent Worker Exposure to Electromagnetic Radiation

General Scenario Description

Accident scenario WORK–04 involves the inadvertent exposure of one or more workers to electromagnetic radiation. Used in this context, electromagnetic radiation refers to exposure to x-rays, accelerator beams, lasers, or radio frequency (RF) sources. Such radiation sources are used widely in various facilities at LANL, especially lasers.

No Action Alternative Frequency Analysis

The WORK–04 accident scenario is meant to represent a class of accidents involving inadvertent exposure of workers to the types of sources described above. Accordingly, there is no unique sequence of events that can be analyzed for frequency and conditional probability. However, these accidents typically involve a failure of an interlock device and/or the failure of the workers to follow procedures

and/or observe precautions that could have prevented the exposure.

Events involving electromagnetic radiation sources that occur more often than once in 10 years (and that have a frequency above 0.1 per year) are accounted for and discussed under the subject of nonionizing radiation elsewhere in the SWEIS. Due to the large number of sources of electromagnetic radiation in use at a broad range of facilities at LANL, it is concluded that, in sum, the frequency of accidents resulting in worker injury or fatality is unlikely to be less than 1 in 100 per year (i.e., a frequency of less than 0.01 per year). This places bounds of 0.01 to 0.1 per year for the WORK–04 accident.

Expanded Operations, Reduced Operations, and Greener Alternatives Frequency Analysis

No significant differences in activity levels are identified that would result in a greater risk of accidental exposure of workers to electromagnetic radiation compared with the No Action Alternative. Thus, no difference in frequency is identified across the alternatives.

Uncertainties and Sensitivities Affecting the Frequency of WORK–04

Uncertainties are not considered to substantially influence the estimated frequency range for this accident due to the large number of potential sources to which workers could be exposed.

TABLE G.5.7.3–2.—Summary Results for Scenario WORK–03

ALTERNATIVE	ACCIDENT FREQUENCY	SOURCE TERM AND CONSEQUENCES
No Action	10 ⁻⁶ to 10 ⁻⁴ /year	Fatalities to nearby workers. No consequences to the public.
Expanded Operations	10 ⁻⁶ to 10 ⁻⁴ /year	Fatalities to nearby workers. No consequences to the public.
Reduced Operations	10 ⁻⁶ to 10 ⁻⁴ /year	Fatalities to nearby workers. No consequences to the public.
Greener	10 ⁻⁶ to 10 ⁻⁴ /year	Fatalities to nearby workers. No consequences to the public.

Administrative controls enforced by LANL management are similar across LANL and should not be associated with significant variation in risk from facility to facility.

Source Term Calculations

This accident does not release hazardous material to the environment; hence, no source term calculations are required.

Uncertainties and Sensitivities Affecting the Source Term for WORK-04

This issue is not applicable to WORK-04 because no source terms are calculated.

Consequences of WORK-04 for Facility Workers and the Public

Due to the nature of facility designs and the nature of the hazards involved, no public impact is expected. Worker consequences could range from minor injuries to major eye injuries, and could include fatalities under some circumstances. The number of workers injured or killed by any given accident would be expected to be small (typically one) because it is unlikely that a group of workers would all violate administrative controls and have this violation result in injury or fatality. This is not to say that this never happens, because it does; but by far and away the most likely outcome is a single worker being affected by any one event. Table G.5.7.4-1 summarizes the analysis results for WORK-04.

G.5.7.5 Work-05, Plutonium Release from Degraded Vault Storage Container at TA-55-4

General Scenario Description

TA-55, the Plutonium Facility at LANL, handles containers of plutonium as part of day-to-day operations. Among the current activities at TA-55 is the repackaging of material stored in vault rooms in the facility’s basement. The plutonium in these containers is being repackaged due to the degraded nature of some of the containers. The repackaging activity is part of a program to implement the DNFSB Recommendation 90-4.

In order to repackage the plutonium, the containers must be retrieved, the plutonium taken out, and the material repackaged. While handling the container, there is the possibility of the container being dropped and some portion of the contents being spilled. If this accident occurs while the building HEPA filters and HVAC systems are operating, very little of the plutonium can escape the facility. Thus, this accident presents the frequency for dropping a degraded container and qualitatively evaluates the exposure of facility workers to this plutonium spill.

The impacts to the public from this type of accident was presented in section G.5.6.10. This discussion presents the frequency for the drop of the container and the exposure of

TABLE G.5.7.4-1.—Summary Results for Scenario WORK-04

ALTERNATIVE	ACCIDENT FREQUENCY	CONSEQUENCES
No Action	0.01 to 0.1/year	Typically one worker injury or fatality; small likelihood of two or more workers being simultaneously affected.
Expanded Operations	0.01 to 0.1/year	Same as No Action Alternative.
Reduced Operations	0.01 to 0.1/year	Same as No Action Alternative.
Greener	0.01 to 0.1/year	Same as No Action Alternative.

workers within the facility only. The public impacts were discussed previously.

For the contents of a container to be spilled, the containers must be corroded or have some other physical damage. LANL has currently retrieved about 1,450 containers and found, through visual inspection, 361 containers to have some defect. Of these 361 containers, 82 have lost outer containment, or approximately 5.5 percent have outer containment failure. The rate of inner containment failure is estimated to be 2 percent. To have a release of material, a container would have to have both its outer and inner container fail during a drop. The contents would then have to be spilled. For this accident, the frequency is therefore dependent on dropping a container that has sufficient damage, such as loss of containment, in order to spill the material.

Once the containers are repackaged, risk will be reduced because of upgrades to the containers and the required stability of the material inside.

For further information, DOE Standard 3013-96 (DOE 1996e) addresses the requirements for containers for long-term (at least 50 years) storage of plutonium. To meet the standard, plutonium-bearing materials must be in stable forms and packaged in containers designed to maintain their integrity under both normal storage conditions and anticipated handling accidents for at least 50 years (DOE 1996e). The standard applies to metal, oxide, and alloys containing at least 50 percent plutonium by mass, and containing less than 3 percent plutonium-238 by mass (DOE 1996e). The quantity of metal per container should be as close as practical to, but not exceed, 9.68 pounds (4.40 kilograms). Stored metal pieces are required to have thicknesses greater than 0.04 inches (1.0 millimeters) and have specific surface areas less than 71 inches²/pounds (1 centimeter²/grams) to reduce potential pyrophoric tendencies (DOE 1996e). The quantity of oxide by container should be as close as practical to, but not exceed, 10.97 pounds

(5.00 kilograms), representing the plutonium dioxide equivalent of 9.68 pounds (4.40 kilograms) of plutonium metal. The oxides are required to be thermally stabilized with less than 0.5 percent mass loss-on-ignition (DOE 1996e). The containers are required to include a minimum of two nested, sealed containers, and have at least one container that remains leak tight after a free drop from a 30-foot (9-meter) height into a flat, essentially unyielding, horizontal surface (DOE 1996e). The containers are required to have a cylindrical geometry not exceeding 4.9 inches (12.5 centimeters) outside diameter or 10 inches (25.4 centimeters) external height (DOE 1996e). Although the risk will be reduced once the plutonium is repackaged, new risk numbers are not calculated. These numbers are considered representative of the type of worker risk that exists when handling plutonium in LANL nuclear facilities.

No Action Alternative Frequency Analysis

Table G.5.7.5-1 summarizes the frequency analysis for a container drop in TA-55. Because there are two types of containers, the frequency for dropping each container is presented. The terms for the equation are explained in subsequent sections. Table G.5.7.5-2 presents the number of container handling operations.

For the purposes of this analysis, the containers are being tracked as two types of containers. Most containers are doubly contained drums, (i.e., drums that have an inner and outer container, and are hermetically sealed). The other type has various names such as food pack cans, or dressing jars. These names were derived from their general appearance to distinguish one container over another. However, these cans would sustain similar damage when dropped. The drums would have a different failure rate than the metal cans when dropped, so the containers are being tracked as two separate types.

TABLE G.5.7.5-1.—Frequency Analysis for a Container Drop in TA-55

SCENARIO	NUMBER OF CONTAINERS HANDLED PER YEAR	HEP FOR CONTAINER DROP	PROBABILITY OF DEGRADED INNER CONTAINER	PROBABILITY OF DEGRADED OUTER CONTAINER	FREQUENCY OF CONTAINER DROP AND SPILL (SPILL PER YEAR)
Drums	972	0.001	0.055	0.02	0.0011
Nonhermetically Sealed Containers	228	0.001	1.0	1.0	0.23

TABLE G.5.7.5-2.—Number of Container Handling Operations

CONTAINER TYPE	TOTAL NUMBER OF CONTAINERS	PERCENTAGE OF CONTAINERS REPACKAGED PER YEAR	NUMBER OF HANDLING OPERATIONS TO REPACKAGE	HANDLING OPERATIONS PER YEAR
Drums	5,830	17	1	972
Metal Cans	1,370	17	1	228

Because the repackaging effort will take approximately 6 years, the repackaging rate was estimated to be 17 percent of the total containers each year.

Each container will be handled once before being placed into a DOE Standard 3013-96 container. Although the entire repackaging process may have additional steps, this is the activity where the material is most likely to be spilled and have worker exposure. Thus, the number of degraded container handling operations is 972 drum operations and 228 metal can operations for a total of 1,200 handling operations of degraded containers per year.

Generally, dropping a container does not involve equipment failure, but rather, errors in setting up the equipment properly. This failure is similar to that of checking the status of equipment, if the status of the equipment affects one’s safety when performing the task (Swain and Guttman 1983). As shown in Table G.5.7.5-3, the probability of dropping a

container, for either type, is therefore estimated to be 0.001.

In order for a container drop to result in a material spill and exposure to workers, a degraded container must be dropped. For drums, the probability of this occurring is assumed to be directly proportional to the number of drums that have both the inner and outer containers damaged. From existing inspections of containers, about 5.5 percent have outer containment failure, and about 2 percent have inner containment failures. Given that the inner containment failure is not linked to outer containment failure, the probability of both of these conditions existing

TABLE G.5.7.5-3.—Human Error Probability (HEP), Container Drop

SCENARIO	HEP, CONTAINER DROP
Drums	0.001
Metal Cans	0.001

is about 0.11 percent (as shown in Table G.5.7.5–4).

For the metal cans, the probability of these containers failing is assumed to be 1.0. These containers were used to pack plutonium metal (LANL 1996k). Although some of these containers had inner and outer containers, they lacked a hermetic seal. Without the hermetic seal, the metal could be oxidized. Also, the inner container was often placed in a plastic bag and then placed inside the outer container. Normally, degradation of the plastic bags was not a problem because the plutonium metal was not stored in them for long periods of time. However, because the plastic bags decompose into various organic compounds through alpha-particle-induced decomposition and can cause the metal and containers to corrode, the plutonium metal must be repackaged. For these reasons, the conservative assumption was made that if a container is dropped then the material is spilled, therefore, by definition, the container is a degraded container.

For workers, the rate of plutonium exposure from these types of accidents is about 1 in 5 years.

Expanded Operations, Reduced Operations, and Greener Alternatives Frequency Analyses

The same type of activities will be conducted for each of the alternatives. Because no appreciable changes in these activity levels are anticipated for the various alternatives, the results of the frequency analysis for the No Action

Alternative remains the same for these alternatives.

Uncertainties and Sensitivities Affecting the Frequency of WORK–05

The assumption that the “metal can” containers will spill material if dropped is considered a conservative assumption for this analysis.

Source Term Calculations

If the entire contents of the package was spilled, the amount of material that could be inhaled is 2.7 grams of plutonium (see section G.5.6.10, Source Term). It is not likely that a worker would inhale this much plutonium. The worker has personnel protective equipment that would be used in response to the accident. Alarms would also sound if plutonium became airborne as part of the accident and limit the exposure of other workers in the area.

Expanded Operations, Reduced Operations, and Greener Alternatives Source Term Analyses

Because the MAR is associated with an individual container-handling operation and LANL will continue to perform these types of activities in order to carry out any assigned mission, the source term would not change.

Worker Consequences

Significant but nonlethal doses are possible to the workers handling the plutonium. Any adverse impacts would be mitigated by prompt use of protective equipment and/or prompt

TABLE G.5.7.5–4.—Probability of Dropping a Degraded Container

SCENARIO	PROBABILITY OF INNER CONTAINMENT FAILURE	PROBABILITY OF OUTER CONTAINMENT FAILURE	PROBABILITY OF HANDLING A DEGRADED CONTAINER
Drums	0.02	0.55	0.0011
Metal Cans	1.0	1.0	1.0

exiting of the immediate vicinity for those not involved in clean-up activities. Table G.5.7.5-5 summarizes the analysis results for WORK-05.

G.6 UNCERTAINTIES AND SENSITIVITIES

In principle, one could estimate the uncertainty associated with each step of the analysis for each accident scenario, and predict the uncertainty in the results (frequency, source term, consequences, risk, etc.). However, conducting such a full-scale quantitative uncertainty analysis is neither practical nor a standard practice for a study of this type. Instead, the analysis is intended to ensure, through judicious selection of release scenarios, models, and parameters that the results represent and bound the actual risks.

This is accomplished by making assumptions at each step of the calculations. The models,

model parameters, and release scenarios are selected in such a way that most intermediate results and the final estimate of impacts are greater than what would be expected should the events actually occur. As a result, even though the range of uncertainty in a quantity might be large, the values selected for quantification are conservative, so the chance that the actual quantity will be greater than the calculated value is low.

The approach taken for quantification of accident risks is such that most of the uncertainty in the results lies on the downside of the values presented. That is, there is a small chance that the actual value lies above those presented, but a very large chance that the actual value lies below those presented in this appendix and in chapter 5 of volume I.

TABLE G.5.7.5-5.—Summary Results for Scenario WORK-05

ALTERNATIVE	ACCIDENT FREQUENCY	WORKER CONSEQUENCES
No Action	0.23	Plutonium exposure to one or two workers. Adverse exposure limited by use of personnel protective equipment.
Expanded Operations	No Change	No Change
Reduced Operations	No Change	No Change
Greener	No Change	No Change

REFERENCES

- Abbott 1988 *A Review of the Radiological Environmental Monitoring Data at U.S. Army Jefferson Proving Ground, Madison, Indiana.* David T. Abbott. Available in draft form from U.S. Army TECOM, AMSTE-SM-S. Aberdeen Proving Ground, Maryland. Undated, but believed to be about 1988.
- ACGIH 1992 *Industrial Ventilation: A Manual of Recommended Practice*, 21st Edition. American Conference of Governmental Industrial Hygienists. Cincinnati, Ohio. 1992.
- AEC 1969 Press release on Rocky Flats Fire. W. B. McCool, Secretary, Atomic Energy Commission. November 13, 1969.
- AICE 1994 *DOW's Fire & Explosion Hazard Classification Guide*, 7th Edition. American Institute of Chemical Engineers. New York, New York. 1994.
- AIHA 1991 *Emergency Response Planning Guidelines.* American Industrial Hygiene Association. November 1991.
- Allen 1996 Allen, Craig D. 1996 Fire Effects in Southwestern Forests, Proceedings of the Second La Mesa Fire Symposium, Los Alamos, New Mexico, March 29-31, 1994. Craig D. Allen, Technical Editor. General Technical Report RM-GTR-286. USDA Forest Service, Fort Collins, CO. September 1996.
- Anderson 1982 Anderson, Hal E. 1982 Aids to determining fuel models for estimating fire behavior. USDA For. Serv. Gen. Tech Rep. INT-122, 22p. Intermt. For. and Range Exp. Stn, Ogden Utah 84401.
- Armstrong 1998 Armstrong, Bill. 1998 Analysis of the Risk of Crown Fire Initiation and Spread in the Valle Ecosystem Management Area on the Española District of the Santa Fe National Forest, Northern New Mexico: A Final Project Submitted for Technical Fire Management. USFS, Española Ranger District Office, Santa Fe National Forest, Española, New Mexico. April 13, 1998.
- Barr 1997 M. Barr, GRAM Team, Memorandum to Bill Rhyne, H&R Technical Associates. Subject: LANL SWEIS. Los Alamos, New Mexico. February 17, 1997.
- Braker and Mossman 1980 *Matheson Gas Data Book*, 6th Edition. W. Braker and A. L. Mossman. Matheson Company, Division of Searle Medical Products USA Inc. Lyndhurst, New Jersey. 1980.

- Campbell et al. 1988 *Compilation of Fragility Information from Available Probabilistic Risk Assessments*, Rev. 1. R. D. Campbell, M. K. Ravindra, and R. C. Murray. Lawrence Livermore National Laboratory, prepared for the U.S. Nuclear Regulatory Commission. UCID-20571. Livermore, California. September 1988.
- CDC 1993 *Biosafety in Microbiological and Biomedical Laboratories*, 3rd Edition. Centers for Disease Control and Prevention, Public Health Service, and National Institutes of Health. HHS Publication No. CDC 93-8395. March 1993.
- Clarke 1976 *Severities of Transportation Accidents*. R. K. Clarke et al. Sandia National Laboratories. SLA-74-0001. Albuquerque, New Mexico. July 1976.
- Coats and Murray 1984 *Natural Phenomena Hazards Modeling Project: Seismic Hazard Models for Department of Energy Sites*. D. W. Coats and R. C. Murray. Lawrence Livermore National Laboratory. UCRL-53582. Livermore, California. 1984.
- Craig et al. 1995 “Alternative Guideline Limits for Chemicals without Environmental Response Planning Guidelines.” D. K. Craig, J. S. Davis, R. DeVore, D. J. Hansen, A. J. Petrocchi, and T. J. Powell. *American Industrial Hygiene Association Journal*. Vol. 56, pp. 919-925. 1995.
- Craig 1996 *ERPGs and TEELs for Chemicals of Concern at SRS: Rev. 11*. D. K. Craig. Savannah River Site, prepared for the DOE Subcommittee on Consequence Assessment and Protective Actions (SCAPA). ECS-CAT-96-0095. October 31, 1996.
- Dexter and Perkins 1982 *Component Failure Rate Data with Potential Applicability to a Nuclear Fuel Plant*. A. H. Dexter and W. C. Perkins. DuPont de Nemours, Savannah River Laboratory. DP-1633, E.1 Aiken, South Carolina. 1982.
- DNFSB 1994 *Improved Schedule for Remediation in the defense Nuclear Complex*, DNFSB Recommendation 94-01. Defense Nuclear Facility Safety Board. 1994.
- DOE 1992 *Hazard Categorization and Accident Analysis Techniques for Compliance with DOE Order 5480.23, Nuclear Safety Analysis Reports*. U.S. Department of Energy. DOE Standard 1027-92. December 1992.
- DOE 1993a *Recommendations for the Preparation of Environmental Assessments and Environmental Impact Statements*. U.S. Department of Energy, Office of NEPA Oversight. May 1993.

- DOE 1993b *Guidelines for Preparing Criticality Safety Evaluations at Department of Energy Non-Reactor Nuclear Facilities.* U.S. Department of Energy. DOE Standard 3007-93. November 1993.
- DOE 1994a *Preparation Guide for U.S. Department of Energy Nonreactor Nuclear Facility Safety Analysis Reports.* U.S. Department of Energy. DOE Standard 3009-94. July 1994.
- DOE 1994b *Hazard Baseline Documentation.* U.S. Department of Energy. DOE EM Standard 5502-94. August 1994.
- DOE 1994c *Atmospheric Dispersion Modeling Resources, Second Edition.* U.S. Department of Energy, Subcommittee on Consequence Assessment and Protective Actions. 1994.
- DOE 1994d *Airborne Release Fractions/Rates and Respirable Fractions for Nonreactor Nuclear Facilities, Vols. I & II.* U.S. Department of Energy. DOE Handbook 3010-94. December 1994.
- DOE 1994e *Natural Phenomena Hazards Design and Evaluation Criteria for Department of Energy Facilities, Change Notice #1, January 1996.* U.S. Department of Energy. DOE Standard 1020-94. April 1994.
- DOE 1994g *DOE Explosives Safety Manual, Revision 7.* U.S. Department of Energy. DOE/EV/06194. August 1994.
- DOE 1995a *Dual Axis Radiographic Hydrodynamic Test Facility Final Environmental Impact Statement.* U.S. Department of Energy, Albuquerque Operations Office and Los Alamos Area Office. DOE/EIS-0228. Albuquerque, New Mexico. August 1995.
- DOE 1995b *Natural Phenomena Hazards Assessment Criteria.* U.S. Department of Energy. DOE Standard 1023-95. 1995.
- DOE 1996a *Final Environmental Impact Statement for the Continued Operation of the Pantex Plant and Associated Storage of Nuclear Weapon Components.* U.S. Department of Energy, Albuquerque Operations Office. DOE/EIS-0225. November 1996.
- DOE 1996b *Chemical Process Hazard Analysis.* U.S. Department of Energy. DOE Handbook 1100-96. February 1996.
- DOE 1996c *Accident Analysis for Aircraft Crash into Hazardous Facilities.* U.S. Department of Energy. DOE Standard 3014-96. October 1996.

- DOE 1996d *Waste Isolation Pilot Plant Disposal Phase Draft Supplemental Environmental Impact Statement, Supplement 2, Draft.* U.S. Department of Energy, Carlsbad Area Office. DOE/EIS-0026. November 1996.
- DOE 1996e *Criteria for Preparing and Packaging Plutonium Metals and Oxides for Long-Term Storage.* U.S. Department of Energy, Office of Defense Programs. DOE Standard 3013-96. September 1996.
- DOE 1996f *Final Programmatic Environmental Impact Statement for Stockpile Stewardship and Management.* U.S. Department of Energy. DOE/EIS-0236. Washington, D.C. September 1996.
- DOE 1996g *Final Environmental Assessment, TRU Waste Drum Staging Building, Technical Area 55, Los Alamos National Laboratory.* U.S. Department of Energy, Los Alamos Area Office. DOE/EA-0823. Los Alamos, New Mexico. February 9, 1996.
- DOE 1997 *Environmental Assessment for the Proposed CMR Building Upgrades at the Los Alamos National Laboratory.* U.S. Department of Energy, Los Alamos Area Office. DOE/EA-1101. Los Alamos, New Mexico. February 4, 1997.
- DOE 1998 *Pit Disassembly and Conversion Demonstration Environmental Assessment and Research and Development Activities.* U.S. Department of Energy, Office of Fissile Materials Disposition. DOE/EA-1207. Washington, D.C. August 1998.
- DPG 1997 Bjorklund, Jay R., James F. Bowers, Gregory C. Dodd, and John M. White 1997. Open Burn/Open Detonation Dispersion Model Users Guide. (Two volumes) DPG-TR-96-008a and DPG-TR-96-008b. West Desert Test Center, U.S. Army Dugway Proving Ground, Dugway, Utah 84022. July 1997.
- Dukes 1995 *MULTUS Database.* L. L. Dukes. INSITE Analysis, Inc. Albuquerque, New Mexico. 1995.
- Eide et al. 1990 *Generic Component Failure Data Base for Light Water and Liquid Sodium Reactor PRAs.* S. A. Eide, S. V. Chmielewski, and T. D. Swantz. EGG-SSRE-8875. Idaho National Engineering Laboratory. Idaho Falls, Idaho. 1990.
- Engelmann 1990 *Effectiveness of Sheltering in Buildings and Vehicles for Plutonium.* Rudolf Engelmann. U.S. Department of Energy. DOE/EH-0159T. Washington, D.C. 1990.

- Engelmann et al. 1991 *Sheltering Effectiveness Against Plutonium Provided by Stationary Automobiles*. R. J. Engelmann, W. R. Pendergrass, J. R. White, and M. E. Hall. ATDD©91/25. Final Report to NASA. National Oceanic and Atmospheric Administration. Oak Ridge, Tennessee. 1991.
- EPA 1987 *Technical Guidance for Hazards Analysis*. U.S. Environmental Protection Agency, with the Federal Emergency Management Agency and the U.S. Department of Transportation. 1987.
- EPA 1991 *Manual of Protective Action Guides and Protective Actions for Nuclear Incidents*. U.S. Environmental Protection Agency. EPA 400-R-92-001. Washington, D.C. October 1991.
- EPA 1996 *Risk Management Plan, Off-Site Consequence Analysis Guidance*. U.S. Environmental Protection Agency. Washington, D.C. 1996.
- Fenner 1996 Letter from H. Allen Fenner, Transportation Planning Division, New Mexico State Highway Department, to W. R. Rhyne. Santa Fe, New Mexico. January 17, 1996
- Fleming et al. 1985 *Classification and Analysis of Reactor Operating Experience Involving Dependent Events*. K. N. Fleming, et al. Pickard, Lowe and Garrick, Inc., prepared for the Electric Power Research Institute. EPRI-NP-3967. Palo Alto, California. June 1985.
- Foxx et al. 1981 Foxx, Teralene S. La Mesa Fire Symposium. LA-9236-NERP Southwest Fire Council, National Park Service, and Los Alamos National Laboratory, October 6 and 7, 1981.
- Fresquez 1994 Memorandum from Fresquez to Greiggs. Subject: "Results of the soil sampling survey conducted over active RCRA firing site TA-15-184 (PHERMEX)." May 26, 1994.
- Garvey 1998 Data obtained from facility walkdowns conducted by GRAM, Inc. and SWEIS Project Office files. August 28, 1998.
- Gephart and Moses 1989 *An Approach to Evaluate the Acute Impacts from Simulated Accidental Releases of Chlorine and Ammonia*. L. Gephart and S. Moses. Plant/Operations Progress, 8:1, Eastman Kodak Company. Rochester, New York. January 1989.
- Greiner 1994 *Los Alamos Airport Master Plan, 1994-2013*. Greiner, Inc. Prepared for Los Alamos National Laboratory. Albuquerque, New Mexico. September 1994.

- INEL 1990 *Nuclear Computerized Library for Assessing Reactor Reliability (NUCLARR), Data Manual, Part 3: Hardware Component Failure Data (HCFD)*, Vol. 5, Rev. 3. Idaho National Engineering Laboratory. Prepared for the U.S. Nuclear Regulatory Commission. NUREG/CR-4639, EGG-2458. Washington, D.C. December 1990.
- Jane's 1995 *All the World's Aircraft*, 85th Edition. Jane's Information Group, Inc. Alexandria, Virginia. 1994–1995.
- LANL 1990a *Los Alamos Climatology*. Los Alamos National Laboratory. LA-11735-MS. Los Alamos, New Mexico. May 1990.
- LANL 1990b *In-Place Testing Summary (1990)*. Los Alamos National Laboratory. LA-UR-91-3101. Los Alamos, New Mexico. May 1990.
- LANL 1991a *Seismic Hazards Investigation, Los Alamos National Laboratory*, unpublished paper. Los Alamos National Laboratory. Los Alamos, New Mexico. August 29, 1991.
- LANL 1991b *In-Place Filter Testing Summary (1991)*. Los Alamos National Laboratory. LA-UR-93-1586. Los Alamos, New Mexico. January 1991.
- LANL 1994a *Specific Activities and DOE-STD-1027-92 Hazard Category 2 Thresholds*. Los Alamos National Laboratory. LA-12846-MS. Los Alamos, New Mexico. November 1994.
- LANL 1994b *Safety Assessment for Compressed Gas Processing Facility, TA-3-170*, Revised. Los Alamos National Laboratory. Los Alamos, New Mexico. April 1994.
- LANL 1994c *In-Place HEPA Filter Testing Summary (1994)*. Los Alamos National Laboratory. Los Alamos, New Mexico. 1994.
- LANL 1994d *In-Place Testing Summary (1992)*. Los Alamos National Laboratory. LA-12792-PR. Los Alamos, New Mexico. September 1994.
- LANL 1994e *Environmental Surveillance at Los Alamos During 1992*. Los Alamos National Laboratory. LA-12764-MS. UC-902. Los Alamos, New Mexico. July 1994.
- LANL 1995a *Technical Areas of Los Alamos National Laboratory, Facility Descriptions and Hazard Classifications*. Los Alamos National Laboratory, Site-Wide Environmental Impact Statement Project Office (EIS-ESH). Los Alamos, New Mexico. December 8, 1995.

- LANL 1995b *Table of DOE-STD-1027-92 Hazard Category 3 Threshold Quantities for the ICRP-30 List of 757 Radionuclides.* Los Alamos National Laboratory. LA-12981-MS. Los Alamos, New Mexico. August 1995.
- LANL 1995c *Final Safety Analysis Report for the Chemistry and Metallurgical Research (CMR) Facility.* Los Alamos National Laboratory. CMR-FAC-95-291. Los Alamos, New Mexico. October 1995.
- LANL 1995d *Final Safety Analysis Report for Radioactive Liquid Waste Treatment Facility at TA-50-1.* Los Alamos National Laboratory. LW-CST-13-AP13, R0. Los Alamos, New Mexico. October 1995.
- LANL 1995e *Final Safety Analysis Report for Waste Characterization Reduction and Repackaging Facility at TA-50-69.* Los Alamos National Laboratory, CST7WCRRF-REPORT-0002, R.1. Los Alamos, New Mexico. October 1995.
- LANL 1995f *Final Safety Analysis Report and Technical Safety Requirements for TA-54, Area G, CST-14.* Los Alamos National Laboratory. CST14G-REPORT-003, R.0. Los Alamos, New Mexico. August 1995.
- LANL 1995g *Hazards Analysis of the Los Alamos National Laboratory Area G, Low-Level Waste and Transuranic Waste Storage Facility.* Los Alamos National Laboratory. LA-UR-95-888. Los Alamos, New Mexico. August 30, 1995.
- LANL 1995h *In-Place HEPA Filter Testing Summary (1993).* Los Alamos National Laboratory. LA-12928-MS. Los Alamos, New Mexico. April 1995.
- LANL 1995i *Final SAR and TSR for the Low-Level Radioactive Waste Disposal and Transuranic Waste Storage Site.* Los Alamos National Laboratory. CST-14G, Report 003, R. 0. Los Alamos, New Mexico. August 1995.
- LANL 1996c *Evaluation of Aircraft Crash Hazard at Los Alamos National Laboratory Facilities.* Los Alamos National Laboratory. LA-13105. Los Alamos, New Mexico. July 1996.
- LANL 1996e *Weapons Engineering Tritium Facility (WETF) Final Safety Analysis Report (FSAR).* Los Alamos National Laboratory. WETF-FSAR, R.0. Los Alamos, New Mexico. March 3, 1996.
- LANL 1996f *Safety Analysis Report for the Los Alamos Critical Experiments Facility (LACEF) and Hillside Vault (PL-26).* Los Alamos National Laboratory. LA-CP-92-235, Rev. 2.0. Los Alamos, New Mexico. February 1, 1996.

- LANL 1996g *Final Safety Analysis Report for Tritium Systems Test Assembly (TSTA), TA-21-155, ESA-TSE.* Los Alamos National Laboratory. TSTA-SAR, R1. Los Alamos, New Mexico. April 1996.
- LANL 1996h *Final Safety Analysis Report for The Tritium Science and Fabrication Facility (TSFF) at TA-21-209.* Los Alamos National Laboratory. TSFF SAR, R0. Los Alamos, New Mexico. May 1996.
- LANL 1996i *Safety Analysis Report for the Radioactive Materials Research, Operations, and Demonstration Facility, TA-50-37.* Los Alamos National Laboratory. RAMROD-REPORT-001, R.0. Los Alamos, New Mexico. April 1, 1996.
- LANL 1996j *Safety Assessment for the Los Alamos National Laboratory Nondestructive Assay/Nondestructive Examination Facility, TA-54 West, Building MD-38.* Los Alamos National Laboratory. CST7RANT-REPORT-002, R.3. Los Alamos, New Mexico. July 1996.
- LANL 1996k *TA-55 Final Safety Analysis Report, TA-55-PRD-108-01.1.* Los Alamos National Laboratory. LA-CP-95-169, Rev. 1. Los Alamos, New Mexico. July 1996.
- LANL 1996l *TA-55 Hazard Analysis.* Los Alamos National Laboratory. LA-CP-94-0076, Revised. Los Alamos, New Mexico. July 1996.
- LANL 1996m *Firing Sites, DOE Review Draft II, Alternatives Description Document.* Prepared by the Los Alamos National Laboratory Site-Wide EIS Project Office. Los Alamos, New Mexico. October 23, 1996.
- LANL 1996n *Final Safety Analysis Report and Technical Safety Requirements for the Retrieval of Transuranic Waste from Pads 1, 2, and 4 at TA-54, Area G.* Prepared for Los Alamos National Laboratory by Benchmark Environmental Corporation. REPORT-54G-11, R.0 and REPORT-54G-12, R.0. Albuquerque, New Mexico. August 21, 1996.
- LANL 1996o *LANL SWEIS Waste Management Strategies, Predecisional Working Draft.* Los Alamos National Laboratory, Waste Management Program Office. Los Alamos, New Mexico. November 1996.
- LANL 1996p *Systems Analysis Results for Los Alamos 94-1 Program.* Presentation at the LANL Stockpile Management Program Review. Los Alamos National Laboratory. Los Alamos, New Mexico. February 6, 1996.
- LANL 1996q *Advanced Recovery and Integrated Extraction System (ARIES) Preconceptual Design Report.* Los Alamos National Laboratory. LA-13178. Los Alamos, New Mexico. September 1996.

- LANL 1996r *Environmental Surveillance at Los Alamos During 1995*. Los Alamos National Laboratory. LA-13210-ENV, UC-902. Los Alamos, New Mexico. October 1996.
- LANL 1997a *Chemical and Metallurgy Research (CMR) Facility Final Safety Analysis Report, Revised Draft*. Los Alamos National Laboratory. CMR-FAC-95-291. Los Alamos, New Mexico. April 1, 1997.
- LANL 1997b *BUS-4 Procedure No. GF-0-19, How to Perform an Inventory of Toxic and Flammable Gases*. Los Alamos National Laboratory. Los Alamos, New Mexico. January 7, 1997.
- LANL 1997c *SWEIS Alternatives Document, Waste Management Key Facility (TA-50, TA-54), Predecisional Draft*. Los Alamos National Laboratory, SWEIS Project Office (ESH-EIS). Los Alamos, New Mexico. January 30, 1997.
- LANL 1997d *Capability Maintenance & Improvements Project (CMIP) Preliminary Hazard Analysis, Working Draft*. Los Alamos National Laboratory. Los Alamos, New Mexico. March 14-1997.
- LANL 1997e *Environmental Surveillance and Compliance at Los Alamos during 1996*. Los Alamos National Laboratory, Environmental Assessments and Resource Evaluations Group. LA-13343-ENV. Los Alamos, New Mexico. 1997.
- LANL 1998a *Description of Technical Areas and Facilities at LANL*. Los Alamos National Laboratory. LA-UR-97-4275. Los Alamos, New Mexico. March 1998.
- LANL 1998b "CMR Basis for Interim Operations." Los Alamos National Laboratory. July 21, 1998.
- Lewis 1993 *Hazardous Chemicals Desk Reference, 3rd Edition*. R. J. Lewis, Sr. Van Nostrand Reinhold. New York, New York. 1993.
- LLNL 1985 *Natural Phenomena Hazards Modeling Project: Extreme Wind/Tornado Hazard Models for Department of Energy Sites, Rev.1*. Lawrence Livermore National Laboratory, prepared for the U.S. Department of Energy. UCRL-53526. Livermore, California. 1985.
- LLNL 1996 *Data Development Technical Support Document for the Aircraft Crash Risk Assessment Methodology (ACRAM) Standard*. Lawrence Livermore National Laboratory, prepared for the U.S. Department of Energy. UCRL-ID-124837. Livermore, California. 1996.

- Lovato and Nielsen 1997 *Response to the GRAM Team Facility Walkdown/Interview Data Collection Document for LANL SWEIS Accident Analysis, TA-3-476, Gas Plant Toxic Gas Storage Shed.* J. Lovato and R. Gonzales-Nielsen. Attachment to February 19, 1997 LANL letter (ESH-EIS:97-038) from Doris Garvey (LANL/ESH-EIS) to Tom Anderson (GRAM, Inc.). Los Alamos National Laboratory. Los Alamos, New Mexico. 1997.
- Mahn et al. 1995 *Qualitative Methods for Assessing Risk.* J. A. Mahn, G. W. Hannaman, and P. M. Krysta. Sandia National Laboratories, prepared for the U.S. Department of Energy. SAND95-0320. Albuquerque, New Mexico. April 1995.
- MGP 1997 *Matheson Gases and Equipment.* Matheson Gas Products. Montgomeryville, Pennsylvania. 1997.
- Miera et al. 1980 F. R. Miera, Jr., W. C. Hanson, E. S. Gladney, and P. Jose. "Mobility of Elevated Levels of Uranium in the Environment." *Natural Environment III.* T. F. Gesell and W. M. Lowder, eds. U. S. Department of Energy CONF-780422 (Vol. 1) pp. 681-699. Washington, D.C. 1980.
- Miller et al. 1995 *A Report on the Seismic Capacity of the General Laboratory and Administration Building at Los Alamos National Laboratory.* C. A. Miller, et al. BNL-61500. Brookhaven National Laboratory. Prepared for Los Alamos National Laboratory. Brookhaven, New York.
- NIOSH 1997 *Pocket Guide to Chemical Hazards.* U.S. Department of Health and Human Services, National Institute for Occupational Safety and Health.
- NRC 1977 *Calculation of Annual Doses to Man from Routine Releases of Reactor Effluents for the Purpose of Evaluating Compliance with 10 CFR 50, Appendix I.* Regulatory Guide 1.109. U.S. Nuclear Regulatory Commission. Washington, D.C. October 1977.
- NRC 1998 *Nuclear Fuel Cycle Facility Accident Analysis Handbook.* NUREG/CR-6410. U.S. Nuclear Regulatory Commission. Washington, D.C. March 1998.
- NSC 1995 *ALOHA™, Areal Locations of Hazardous Atmospheres User's Manual.* U.S. Environmental Protection Agency, National Safety Council, Chemical Emergency Preparedness and Prevention Office, and National Oceanic and Atmospheric Administration Hazardous Materials Response and Assessment Division. June 1995.
- NWCG 1982 *National Wildfire Coordinating Group. General Technical Report INT-122.* April 1982.
- Odum 1971 *Odum, E. P. Fundamentals of Ecology.* W. B. Saunders, Philadelphia. 1971.

- Oswald et al. 1982 *Generic Data Base for Data and Models Chapter of the National Reliability Evaluation Program (NREP) Guide*. A. J. Oswald, et al. Idaho National Engineering Laboratory, prepared for the U.S. Nuclear Regulatory Commission. EGG-EA-5887. June 1982.
- Paternoster et al. 1995 *Safety Analysis Report for the Los Alamos Critical Experiments Facility and the Hillside Vault*. R. R. Paternoster, R. E. Anderson, and E. M. Mullen. Los Alamos National Laboratory. Los Alamos, New Mexico. September 1995.
- PC 1996b Internal LANL e-mail from D. E. Volkman to D. Seide, regarding Summary of Seismic Capability of Key LANL Buildings. Los Alamos National Laboratory. April 7, 1996.
- PC 1997 Telecon between Stephanie Cohen, Los Alamos National Laboratory ESH-1, and Dr. Mohammed Abu-Shehadeh. April 4, 1997.
- PC 1998 Personal communication between Jack Hill and Nannette Founds, regarding meteor strikes. January 1998.
- PC 1998b Baars, J. Personal Communication from Bandelier National Monument. Los Alamos National Laboratory. Los Alamos, New Mexico. 1998.
- PC 1998c Balice, Randy. Personal Communication, Summary of Fuels by Forest-topography class. Los Alamos National Laboratory. August 12, 1998.
- PC 1998d Katzman, Dan. Environmental Restoration Program, LANL. Personal Communication via Wayne C. Hanson. Concentrations in DP Canyon. August 19, 1998
- PC 1998e Pratt, Allyn. Personal Communication to Rudolf Engelmann, SAIC. Los Alamos National Laboratory. September 11, 1998.
- PC 1998f Darling, Gene. Personal Communication to Rudolf Engelmann, Population Information for Los Alamos. August 25, 1998.
- RAC 1991 *Non-Electric Parts Reliability Data*. Reliability Analysis Center. Report NPRD-91. Rome, New York. May 1991.
- RFETS 1994 *Rocky Flats Risk Assessment Guide*, Revision 3. Rocky Flats Environmental Technology Site. Golden, Colorado. September 30, 1994.
- Rhyne 1994 *Risk Management of the Transport of Drums Containing Transuranic Waste from TA-55 to TA-54*. W. R. Rhyne. Prepared for Los Alamos National Laboratory by H&R Technical Associates, Inc. H&R 503-1. Oak Ridge, Tennessee. July 1994.

- Sehmel 1984 Sehmel, George. 1984 Deposition and Resuspension. In Atmospheric Science and Power Production, DOE/TIC-27601. U.S. Department of Energy, 1984. pp. 533-583.
- Simard et al. 1989 Simard, Albert J., Richard W. Blank, and Sharon L. Hobrta. Measuring and Interpreting Flame Height in Wildland Fires. *Fire Technology*, May 1989. p. 114-133.
- SNL 1990 *Procedures for the External Event Core Damage Frequency Analyses for NUREG-1150*. Sandia National Laboratories, prepared for the U.S. Nuclear Regulatory Commission. NUREG/CR-4840 and SAND88-3102. November 1990.
- Steele et al. 1997 *Plutonium Explosive Dispersal Modeling Using the MACCS 2 Computer Code*. C. M. Steele, T. L. Wald, and D. I. Chanin. U.S. Department of Energy, Los Alamos Area Office. September 1997.
- Swain and Guttman 1983 *Handbook of Human Reliability Analysis With Emphasis on Nuclear Power Plant Applications, Final Report*. A. D. Swain and H. E. Guttman. Sandia National Laboratories, prepared for the U.S. Nuclear Regulatory Commission. NUREG/CR-1278 and SAND80-0200. Albuquerque, New Mexico. August 1983.
- U.S. Army et al. 1990 *Structures to Resist the Effects of Accidental Explosions*. U.S. Departments of the Army, the Navy, and the Air Force. TM 5-1300/NAVFAC P-397/ARF 88-22. Washington, D.C. November 19, 1990.
- Valentine and Pendergrass 1997 *TSFF TA-21-209 Accident MAR*. Informal LANL memorandum from Allen Valentine and Ann Pendergrass (ESH-EIS) to Doris Garvey (ESH-EIS). Los Alamos, New Mexico. April 7, 1997.
- Vogt 1997 "Empirical Investigations of the Diffusion of Waste Air Plumes in the Atmosphere." K. J. Vogt. *Nuclear Technology*, Vol. 34, pp. 43-57. 1977.
- Wenzel et al. 1987 Wenzel, W. J., T. S. Foxx, A. F. Gallegos, G. Tierney, and J. C. Rodgers. Cesium-137, Plutonium-239/240, Total Uranium, and Scandium in Trees and Shrubs Growing in Transuranic Waste at Area B. 1987.
- WHC 1995 *Drum Drop Test Report*. Westinghouse Hanford Corporation. WHC-SD-WM-TRP-231, Rev. 0. Richland, Washington. 1995.
- Whicker and Schultz 1982 *Radioecology: Nuclear Energy and the Environment*. F. Ward Whicker and Vincent Schultz. Vol. 2 of 2 volumes. CRC Press. Boca Ratan, Florida. 1982.

- Wilgen et al. 1990 Wilgen, B. W. Van, K. B. Higgins, and D. U. Bellstedt. The Role of Vegetation Structure and Fuel Chemistry in Excluding Fire from Forest Patches in the Fire-Prone Fynbos Shrublands of South Africa. *Journal of Ecology*, 78:210-222. 1990.
- Wong et al. 1995 *Seismic Hazards Evaluation of the Los Alamos National Laboratory*, Final Report, Vol. III. I. Wong, et al. Woodward-Clyde Federal Services. Oakland, California. February 24, 1995.
- Young 1998 "LANL Wildfire Analyses." M. L. Young. Los Alamos National Laboratory. October 1998.

APPENDIX H
SUPPLEMENTAL ANALYSIS FOR THE ENHANCEMENT
OF PIT MANUFACTURING AT LOS ALAMOS NATIONAL
LABORATORY, STOCKPILE STEWARDSHIP AND
MANAGEMENT PROGRAMMATIC ENVIRONMENTAL
IMPACT STATEMENT



Department of Energy
Washington, DC 20585

March 13, 1998

MEMORANDUM FOR GENE IVES
DEPUTY ASSISTANT SECRETARY FOR MILITARY
APPLICATIONS AND STOCKPILE MANAGEMENT

ROBIN STAFFIN
DEPUTY ASSISTANT SECRETARY FOR RESEARCH
AND DEVELOPMENT

FROM: Victor H. Reis *[Signature]*
Assistant Secretary for Defense Programs

SUBJECT: Determination re: Supplement Analyses for the National Ignition Facility
(NIF) and Pit Production at Los Alamos National Laboratory (LANL)

I have reviewed the attached Supplement Analyses on (1) the Use of Hazardous Materials in NIF Experiments at LLNL and (2) Enhancement of Pit Manufacturing at LANL in accordance with applicable Departmental regulations as well as your March 11, 1998, memorandum. I have approved the Supplement Analyses and have concluded that: (1) there are no substantial changes in the proposed actions that are relevant to environmental concerns; and (2) there are not significant new circumstances or information relevant to environmental concerns and bearing on the proposed actions or their impacts. Therefore, I have determined, that in accordance with 40 CFR 1502.9(c) and 10 CFR 1021.314(c), that neither a new Stockpile Stewardship and Management (SSM) Programmatic Environmental Impact Statement (PEIS) nor a supplement to the existing SSM PEIS is required.

Attachment

cc: B. Twining, AL
J. Turner, OAK

Concurrence: *[Signature]* 3/12/98
GC-51
for William J. Dennison
Assistant General Counsel for Environment



Printed on recycled paper

Supplement Analysis: Enhancement of Pit Manufacturing at LANL, SSM PEIS

**SUPPLEMENT ANALYSIS:
ENHANCEMENT OF PIT MANUFACTURING
AT LOS ALAMOS NATIONAL LABORATORY,
STOCKPILE STEWARDSHIP AND MANAGEMENT
PROGRAMMATIC ENVIRONMENTAL IMPACT STATEMENT**

March 1998

SUMMARY

Recently, several issues have been raised regarding whether or not the 1996 Department of Energy (DOE) Stockpile Stewardship and Management (SSM) Programmatic Environmental Impact Statement (PEIS) analysis of locating an enhanced pit manufacturing capability at Los Alamos National Laboratory (LANL) should be supplemented due to new or overlooked information. Broadly, these issues have to do with: whether or not connected facilities were considered in the SSM PEIS; whether or not the upgrades to deteriorating facilities at LANL should have been considered in the SSM PEIS; and whether or not more recent information should be considered.

DOE has analyzed these issues in this Supplement Analysis and has concluded that there is no need to prepare a supplemental SSM PEIS to address reestablishing pit fabrication capability. The issues raised were either covered in the SSM PEIS and so were available to the decisionmaker; were project-specific issues related to the implementation of SSM decisions at LANL and so would be subject to subsequent tiered environmental review and decisionmaking; or were preliminary information and so would be subject to future review at such time as they are ripe for decision. Through this Supplement Analysis DOE recommends that neither a Supplemental PEIS, a new EIS, nor an amended ROD be prepared.

INTRODUCTION

Purpose of this Document

This document is a Supplement Analysis prepared to assist the Department of Energy (DOE) to determine whether or not to prepare a Supplemental Programmatic Environmental Impact Statement (PEIS) for its Stockpile Stewardship and Management (SSM) Program. This Supplement Analysis specifically addresses the issue of those aspects of DOE's nuclear weapons pit manufacturing capability and capacity (a "pit" is a central component of a nuclear weapon) that were assigned to Los Alamos National Laboratory (LANL) in the SSM Record of Decision (ROD).

Background - SSM PEIS

Before addressing whether or not the SSM PEIS should be supplemented, consideration of some background information regarding the PEIS, its intent, the decisions reached, and the formulation of issues, is presented. This information assists in arriving at conclusions and recommendations regarding supplementing the SSM PEIS, preparing a new EIS to address pit manufacturing, or changing the SSM ROD. The SSM PEIS was prepared in accordance with the National Environmental Policy Act (NEPA) [42 USC 4321 et seq.], the Council on

Supplement Analysis: Enhancement of Pit Manufacturing at LANL, SSM PEIS

Environmental Quality (CEQ) NEPA implementing regulations [40 CFR 1500], and the DOE NEPA implementing regulations [10 CFR 1021].

In March 1996 DOE published a Draft PEIS on its nuclear weapons SSM Program [A.R. No. 1-1385]; DOE published the Final SSM PEIS in September 1996 [DOE/EIS-0236, A.R. No. 1-1561]. The SSM PEIS analyzed how DOE might carry out its nuclear weapons mission assignments, at a programmatic level, including alternative locations where DOE might assign various SSM missions. A ROD, based in part on the environmental analyses in the SSM PEIS, was issued on December 19, 1996 [61 FR 68014, A.R. No. 1-1606, A.R. No. VII.B-26]. The SSM PEIS and ROD were intended to address the programmatic decisions facing DOE regarding implementation of its SSM Program. A two-tiered NEPA strategy was adopted, wherein implementing the programmatic decisions at a site-specific level in many cases would be accomplished through subsequent tiered project-specific NEPA reviews [SSM PEIS Vol. I, Sec. 1.5, p. 1-8; see also SSM ROD, Sec. 3.A.4].

The SSM PEIS and the SSM ROD covered those proposed actions which were the salient decision factors for determining how DOE would implement the SSM program for the foreseeable future. One of the proposals involved "Reestablishing Manufacturing Capability and Capacity for Pit Components" [SSM PEIS, Vol. I, Sec. 2.5.3, p. 2-11]. Capability is the practical ability to perform a basic function, and SSM capabilities are needed independent of future nuclear weapons stockpile sizes. Capacity is the size of the capability; in other words, the number of components that could be fabricated at a specific facility or a specific time. The SSM PEIS analyzed the potential capacity at different sites to support a potential nuclear weapons stockpile of various sizes (numbers of weapons) in order to examine the sensitivity of programmatic decisions to transfer weapons manufacturing activities to sites such as LANL. [SSM PEIS Vol. I, Sec. 1.1, p. 1-2.]

DOE needed to reestablish the capability to produce stockpile-ready pits that was lost when in 1992 DOE ceased plutonium pit manufacturing operations at its Rocky Flats Plant (RFP) (now known as the Rocky Flats Environmental Technology Site) in Colorado [SSM PEIS Vol. I, Sec. 2.5.3, p. 2-11]. The programmatic question addressed in the SSM PEIS and ROD related to pit fabrication was which DOE site should receive this mission assignment. Programmatic alternatives for locating pit fabrication alternatives were limited to sites which had some level of technical or facility infrastructure [SSM PEIS Vol. I, Sec. 2.5.3, p. 2-11; SSM PEIS Vol. I, Sec. 3.4.3, p. 3-57]. SSM PEIS alternatives included reestablishing pit capability and capacity at the DOE's LANL; reestablishing the capability and capacity at the DOE's Savannah River Site (SRS); or to continue to rely on the existing capability and capacity at LANL and the DOE's Lawrence Livermore National Laboratory (LLNL). LANL's facility infrastructure is located in several buildings at different Technical Areas (TAs). The three siting alternatives discussed and analyzed in the SSM PEIS were:

1. No Action (continue to use existing limited capabilities at LANL and continue to use the limited capability at LLNL to support material and technology development);
2. Reestablish pit fabrication at LANL (use existing facilities at TA-55, -3, -8, -50 and -54, and construct some upgrades);
3. Reestablish pit fabrication at SRS (use space in existing "hardened" nuclear facilities with extensive equipment and construction upgrades).

The SSM PEIS provided a comparative analysis of the programmatic impacts that would be expected to occur if the pit fabrication capability were to be reestablished at either LANL or SRS, compared against the No Action baseline [SSM PEIS, Vol. I, Section 4.6.3, p. 4-276]. Because construction of new buildings was not anticipated to be needed in order to assign the pit fabrication mission to LANL, notable environmental impacts were primarily limited to those from operations, such as radiological impacts, and socioeconomics. If the pit fabrication mission had been relocated to SRS, some new construction would have been needed [SSM PEIS, Vol. I, Section 4.3.3, p. 4-107]. Appendix A [SSM PEIS, Vol. II, Sec. A.1.5, p. A-28] provided greater detail of the Defense Programs Facilities in use at LANL, including the Chemical and Metallurgical Research (CMR) Building and Sigma Complex at TA-3, and the plutonium (Pu) facilities at TA-55 [Table A.1.5-1]. Similar, but less detailed

Supplement Analysis: Enhancement of Pit Manufacturing at LANL, SSM PEIS

information, for SRS was also presented [SSM PEIS, Vol. II, Sec. A.1.2, p. A-10]. Appendix A also discussed the specific facilities anticipated to be used for pit fabrication at LANL [SSM PEIS, Vol. II, Sec. A.3.3.1, p. A-117]; a list of specific facilities (including CMR and Sigma at TA-3, and the Plutonium Facility (PF) 4 and Nuclear Materials Storage Facility (NMSF) at TA-55) and type of construction was provided [SSM PEIS, Vol. II, Table A.3.3.1-1]. The text pointed out that if LANL were selected as the pit fabrication site, the then-current stockpile pit rebuild program at LANL would be absorbed within the pit fabrication effort since the activity would be the same -- only the number of pits would be different (greater) [SSM PEIS Vol. II, p. A-120]. Similar information was provided for SRS [SSM PEIS Vol. II, Sec. A.3.3.2, p. A-124].

In December 1996 DOE issued its programmatic decisions regarding how it would implement the SSM Program. The SSM ROD was based on more than just the environmental analysis of the SSM PEIS. DOE considered "other factors such as DOE statutory mission requirements, national security policy, cost, schedule, and technical risks. Additional technical descriptions and assessments of cost, schedule and technical risk are found in the Analysis of Stockpile Management Alternatives (DOE/AL, July 1996), the Stockpile Management Preferred Alternatives Report (DOE/AL, July 1996) ..." [SSM ROD, Supplementary Information - Background]. The technical and cost analyses for production capability and capacity alternatives analyzed in the SSM PEIS were covered in the draft "Stockpile Management Preferred Alternatives Report" [A.R. No. I-1381] and the "Analysis of Stockpile Management Alternatives" [A.R. No. I-1381], both dated February 1996, mentioned in the Final SSM PEIS [see, for example, SSM PEIS Vol. IV, comment response 40.18, p. 3-107]. The analyses in these reports showed that compared to SRS, locating the pit fabrication mission at LANL would be lower in cost and have less technical risk because LANL had recent experience in providing pits for nuclear explosive testing [SSM PEIS Vol. IV, comment response 32.03, p. 3-81; 32.06, p. 3-81]. These draft reports mentioned in the SSM PEIS were released in final form in July 1996 [A.R. No. I-1506] following the SSM PEIS and were used by the decisionmaker in determining SSM Program implementation decisions.

The DOE SSM decision regarding reestablishing pit fabrication was:

...to reestablish the pit fabrication capability, at a small capacity, at LANL. ... This decision limits the plutonium fabrication facility plans to a facility sized to meet expected programmatic requirements over the next ten or more years. It is not sized to have sufficient capacity to remanufacture new plutonium pits at the same production rate as that of their original manufacture. DOE will perform development and demonstration work at its operating plutonium facilities over the next several years to study alternative facility concepts for larger capacity. Environmental analysis of this larger capacity has not been performed at this time because of the uncertainty in the need for such capacity and the uncertainty in the facility technology that would be utilized. Should a larger pit fabrication capacity be required in the future, appropriate environmental and siting analysis would be performed at that time.

Mitigation. Specific mitigation measures are not addressed for the stockpile management decisions of the ROD, although many potential mitigation measures are identified in the PEIS. In accordance with the Stockpile Stewardship and Management Program's two-tiered NEPA Strategy, these specific mitigation measures will be addressed, as necessary, on a site-by-site basis, in any site-specific NEPA analyses needed to implement the stockpile management decisions of this ROD.

[ROD, Sec. 3.A.4]

In May 1997, a coalition of 39 organizations headed by the Natural Resources Defense Council (NRDC) brought action against DOE for alleged failure, among other things, "to adequately analyze the environmental effects of, and reasonable alternatives to" the SSM Program [NRDC v. Peña, Complaint for Declaratory and Injunctive Relief, May 2, 1997, p. 7]. In an amended complaint plaintiffs brought action against DOE for alleged failure, among other things, "to prepare a Supplemental [PEIS] based upon significant new information regarding the potential environmental impacts arising from ... the fabrication of nuclear weapon cores, or pits, at [LANL]"

Supplement Analysis: Enhancement of Pit Manufacturing at LANL, SSM PEIS

[NRDC v. Peña, Amended Complaint for Declaratory and Injunctive Relief, January 30, 1998, p. 6 - 7]. The amended complaint included an affidavit from NRDC researcher Christopher Paine (Paine Affidavit) dated January 30, 1998, which among other things gave five reasons why plaintiffs believe a supplemental SSM PEIS was needed to further address pit production at LANL.

RECENT ISSUES RELATED TO PIT PRODUCTION**Overview**

This Supplement Analysis has been prepared to determine whether to supplement that portion of the SSM PEIS which deals with the proposed action to reestablish a manufacturing capability and capacity for pits. It specifically looks at the five points raised by the Paine Affidavit, which are alleged to warrant preparation of a supplemental SSM PEIS. It also examines four issues which were raised by DOE because they may have some bearing on addressing points raised by Paine. The following section describes the issues raised by plaintiffs and by DOE.

Issues Raised by Plaintiff NRDC et al.

The Amended Complaint of January 30, 1998, among other things, asks that a supplemental SSM PEIS be prepared to address pit production at LANL. Reference is made to PF-4, TA-55, which is the main plutonium processing facility at LANL, the CMR Building at TA-3, and NMSF at TA-55. The following five issues and claims of alleged new information regarding DOE's pit production mission at LANL were identified by plaintiffs NRDC, et al., in their amended complaint and accompanying memorandum and supporting documents.

1. **Impacts at TA-55, PF-4.** That all proposed activities analyzed in the SSM PEIS for the LANL pit production mission were assumed to take place at TA-55, PF-4, and that impacts from connected actions were omitted. (Plaintiffs' Memorandum of Points and Authorities, Ex. 1, Affidavit of Christopher Paine, paragraph 19.)
2. **Connected actions.** That the Final PEIS did not identify and assess the connected and cumulative environmental impacts of six projects related to pit production, costing on the order of \$1 billion. Those six projects are:
 - (a) Modernize facilities and infrastructure at TA-55, particularly PF-4, to allow the continuing safe nuclear materials processing operations needed for pit fabrication through FY 2020.
 - (b) Modernize the facilities and infrastructure of the TA-3 Sigma Complex for fabricating nonnuclear (e.g. beryllium, vanadium, uranium) pit components.
 - (c) Relocate selected environmentally sensitive nuclear materials missions from TA-55 to CMR to provide sufficient space for expanded pit manufacturing operations at TA-55, a decision that is now under active reconsideration and may be abandoned.
 - (d) Add sufficient analytical chemistry to the CMR facility to support increased pit production rates.
 - (e) Establish a Special Nuclear Material Transportation Corridor between TA-55 and the CMR facility.
 - (f) Renovate NMSF to accommodate increased plutonium inventory resulting from a planned increase in pit surveillance and pit fabrication operations.

(Plaintiffs' Memorandum of Points and Authorities, Ex. 1, Affidavit of Christopher Paine, paragraph 20.)
3. **Surge planning scenario.** That the PEIS analysis is outdated because it did not analyze the reasonable foreseeable environmental impacts from DOE's approved surge planning scenario for fabricating up to 500 pits per year at multiple sites. (Plaintiffs' Memorandum of Points and Authorities, Ex. 1, Affidavit of Christopher Paine, paragraph 21.)

Supplement Analysis: Enhancement of Pit Manufacturing at LANL, SSM PEIS

4. **DNFSB safety consideration.** That the PEIS inadequately considered safety consideration associated with the CMR Building, identified in part in a December 1997 DNFSB report to DOE. (Plaintiffs' Memorandum of Points and Authorities, Ex. 1, Affidavit of Christopher Paine, paragraphs 22 and 23.)
5. **Accidents involving Pu-238.** That the PEIS omitted any analysis of accident consequences involving release of Pu-238, where information indicates that two-thirds of the PF-4 space at TA-55 slated for processing Pu-238 would be located in the same building as pit fabrication activities. (Plaintiffs' Memorandum of Points and Authorities, Ex. 1, Affidavit of Christopher Paine, paragraph 24.)

Issues Raised by DOE

The SSM ROD assigned the mission to reestablish its pit fabrication capability, at a small capacity, at LANL. DOE's plans for implementing the pit production mission at LANL have evolved, organizational changes have been accomplished, and new studies have been initiated regarding regional environmental features. The pertinent issues that have been raised by DOE over the past several months, which bear on the issues raised by plaintiffs, are as follows.

1. **Pit production strategy.** That DOE approved a modified strategy for pit fabrication in December 1997 and in January 1998 directed LANL to pursue the modified strategy. The strategy in general addressed engineering project management, scheduling, and logistics issues. The three objectives of the new strategy are:
 - (a) Decouple the specific DOE project for pit fabrication, which is included in the Capability Maintenance and Improvements Project (CMIP), from other projects and focus development of pit production capability at TA-55 without disrupting ongoing mission.
 - (b) Maintain pit production as a continuous process, and achieve an intermediate capacity of 20 pits per year by FY 2007 without prejudice to the eventual 50 pit per year capacity.
 - (c) Delay CMIP while performing urgent maintenance and equipment replacement beginning in FY 1999.
2. **CMR project management considerations.** That in early 1997 DOE and LANL decided to temporarily suspend construction activities for the CMR upgrades project pending a thorough budget and project management review.
3. **CMR safety reviews and organizational changes.** That on September 2, 1997, in response to safety considerations, LANL temporarily suspended operations within the CMR building pending an in-depth review of all operations and procedures being implemented within the building to support on-going LANL missions. Operations were resumed over time in a phased manner as work control and work authorization procedures were verified for each on-going project within the building.
4. **New earthquake faulting studies at LANL.** That new studies initiated in 1997 indicate an increased likelihood of geologic rupture should certain seismic events occur.

ANALYSIS OF ENVIRONMENTAL ISSUES RAISED

Analysis

For each of the issues outlined above, this Supplement Analysis examines the following factors:

- (a) Is the issue germane to a NEPA analysis?
- (b) Does the issue represent a substantial change to the proposal analyzed in the SSM PEIS?

Supplement Analysis: Enhancement of Pit Manufacturing at LANL, SSM PEIS

- (c) Does the issue present significant new circumstances or information relevant to environmental concerns that was not available to the decisionmaker at the time the SSM ROD was issued?
- (d) Would the issue, if known at the time, have affected the outcome of the programmatic decisions in the SSM ROD?

If the Supplement Analysis leads to the conclusion that the decisions in the SSM ROD were based on an obsolete analysis, and if new information could have led to a different programmatic decision regarding where to locate the reestablished pit fabrication capability, then the SSM PEIS should be supplemented. If the Supplement Analysis leads to the conclusion that the information raised in the issue was incorporated in the SSM PEIS or otherwise known to the decisionmaker at the time the SSM ROD was issued; that the information pertains to site-specific implementation of programmatic decisions; or that the information is irrelevant to a NEPA review; then the SSM PEIS need not be supplemented.

Analysis of Issues Raised by Plaintiffs

1. Impacts at TA-55, PF-4. That all proposed activities analyzed in the SSM PEIS for the LANL pit production mission were assumed to take place at TA-55, PF-4, and that impacts from connected actions were omitted.

The alternative to reestablish pit fabrication at LANL is discussed in the SSM PEIS in Chapter 3 [SSM PEIS Vol. I, Sec. 3.4.3.2, p. 3-58] which in turn refers to a more detailed discussion in Appendix A [SSM PEIS Vol. II, Appendix A, Sec. A.3.3.1, p. A-117]. Appendix A, Table A.3.3.1-1, lists six separate buildings projected to be used for pit fabrication if the mission were located at LANL. Therefore it was understood that more than one facility would be used for pit fabrication activities at LANL. [See also the Declaration of Paul T. Cunningham, June 6, 1997, paragraph 5.]

The SSM PEIS provided an analysis of those factors that allowed the decisionmaker to discriminate between locating the pit fabrication capability at LANL or SRS. The SSM PEIS focused on major facilities and omitted minor facilities [SSM PEIS, Vol. II, Sec. A.1.5, p. A-28]. The programmatic analysis was based on bounding scenarios for potential impacts at the two sites considered, and the level of detail that appeared in the SSM PEIS was sufficient for the decision to be made – that of placement of mission.

Environmental impacts from reestablishing pit fabrication at LANL were analyzed in Chapter 4 [SSM PEIS, Vol. I, Sec. 4.6.3, p. 4-276]; impacts to the several facets of the environment were projected based on the description of the alternatives in Appendix A. The discussions under many of the facets made reference to the multiple TAs involved in the proposal: see, for example, the discussion for cultural resources [SSM PEIS, Vol. I, Sec. 4.6.3.7, p. 4-291] which specifically addressed the potential for impacts at each of six TAs. The Paine Affidavit issue specifically addressed impacts for waste management, air quality, and surface water. The PEIS impact analysis for waste management referenced LANL “facilities” in the plural [SSM PEIS, Vol. I, Sec. 3.4.3.2, p. 3-61]; that for air quality was based on either actual stacks or a hypothetical centrally located stack [SSM PEIS, Vol. II, Sec. B.3.6, p. B-14]; that for surface water resources referenced “TAs” in the plural [SSM PEIS, Vol. I, Sec. 4.6.3.4, p. 4-283]. Therefore, where appropriate impacts were analyzed for more than just TA-55.

The SSM PEIS provided a comparative analysis of the action alternatives against the No Action alternative, which served as a reference base [SSM PEIS, Vol. II, Sec. A.1, p. A-1]. Each of the two sites analyzed in the SSM PEIS, LANL and SRS, have an existing infrastructure associated with nuclear operations; hence the impacts associated with locating the pit fabrication mission were additive to the No Action impacts from missions already at each site. The No Action alternative assumed that the sites would continue to operate until at least 2005 with existing facilities that could comply with environment, safety and health requirements, and that facilities would be subject to routine maintenance and repairs. Therefore, the impacts of reasonably foreseeable facility repairs and workloads were included in the No Action baseline.

Supplement Analysis: Enhancement of Pit Manufacturing at LANL, SSM PEIS

Consideration of whether actions are connected in the sense of NEPA is useful to determine whether they should be analyzed together, as in a programmatic review such as the SSM PEIS, rather than separately [40 CFR 1508.25(a)(1)]; it is appropriate to consider in one programmatic analysis the impacts from establishing connected pit fabrication activities in several facilities. The SSM PEIS did this. In keeping with the two-tiered NEPA strategy outlined in the SSM PEIS [SSM PEIS, Vol. I, Sec. 1.5, p.1-8], DOE decided that the impacts of implementing programmatic decisions at a site-specific level would be addressed in subsequent tiered project-specific NEPA reviews [SSM ROD Sec. 3.A.4].

The LANL Site Wide EIS (SWEIS), currently in preparation in accordance with 10 CFR 1021.330(c), will provide a site-specific look at the cumulative impacts of operating LANL; it will also analyze four alternative ways to continue to operate the entire site for the next ten years [Advance Notice of Intent (ANOI) to prepare the SWEIS [59 FR 40889, August 10, 1994], A.R. No. VII.B-14; Notice of Intent to prepare the SWEIS [60 FR 25697, May 12, 1995], A.R. No. VII.B-18; LANL SWEIS Implementation Plan [DOE/EIS-0238], November 1995, A.R. No. VII.B-20]. The four planned draft alternatives are:

- (a) No Action - continue LANL operations at their current planned level.
- (b) Expanded Operations - implement all current DOE mission element assignments to LANL at the highest foreseeable level of activity and fully implement recent mission assignments.
- (c) Reduced Operations - conduct the minimal level of activity necessary to maintain capabilities necessary to support DOE missions.
- (d) Greener Operations - use LANL capabilities to minimize support to DOE defense and nuclear weapons missions, and maximize support to other DOE mission elements.

The LANL SWEIS will consider the impacts of implementing the SSM programmatic decisions at LANL. It will consider enhancement of the existing pit manufacturing capability at LANL, and is expected to provide a project-specific NEPA review for certain aspects of the SSM ROD pit fabrication mission assignment, including CMIP. The SSM PEIS looked at pit fabrication needs over the next 10 or more years, essentially the same timeframe as the LANL SWEIS analysis. Under the No Action Alternative (the base case in the SWEIS analysis), LANL could continue to fabricate pits at the existing capability level (approximately a pit per month); under the Expanded Operations alternative, LANL could fabricate 50 pits per year (using a single labor shift) or achieve 80 pits per year (the surge level indicated in the SSM PEIS) within the 10-year timeframe; and under the other two alternatives LANL could maintain a pit manufacturing capability but produce pits at a lesser number.

The Draft LANL SWEIS is currently scheduled for release to the public for review and comment in May 1998. The Final SWEIS is scheduled for November 1998, and the ROD for late 1998.

The issue is in error regarding the allegation that only TA-55 was considered in the SSM PEIS; the SSM PEIS analysis was based on the projection that several major and minor facilities at LANL would be involved in pit fabrication. The issue provides no new information that was not available to the SSM decisionmaker. Therefore, no change to the SSM PEIS is warranted.

2. Connected actions. That the Final PEIS did not identify and assess the connected and cumulative environmental impacts of six projects related to pit production, costing on the order of \$1 billion. Those six projects are:

- (a) modernize facilities and infrastructure at TA-55, particularly plutonium Facility 4, to allow the continuing safe nuclear materials processing operations needed for pit fabrication through FY 2020;**

The SSM PEIS limited its review of alternative locations for reestablishing pit fabrication to those sites that already had some measure of the appropriate technical or facility infrastructure [SSM PEIS Vol. I, Sec. 2.5.3, p. 2-11];

Supplement Analysis: Enhancement of Pit Manufacturing at LANL, SSM PEIS

only two sites, LANL and SRS, qualified. At LANL the preexisting plutonium capability existed largely at TA-55, which contributed to LANL qualifying as an alternative site. Facilities at LANL such as TA-55 are used to support a variety of mission needs for a variety of sponsors [SSM PEIS Vol. I, Sec. 3.2.6, p. 3-18; Table 3.2.6-1, p. 3-19]. TA-55 is one of the newer facilities at LANL (first occupied in the late 1970s); like all buildings it requires periodic maintenance in order to continue to operate. The SSM PEIS indicated that no facilities at LANL would be phased out regardless of decisions on pit fabrication stemming from the SSM PEIS [SSM PEIS Vol. I, Sec. 4.6.1, p. 4-246]. It is essential to maintain the nuclear infrastructure at LANL in safe operating condition and perform upgrades when necessary to achieve environment, safety and health goals. Therefore, the SSM PEIS decisionmaker was aware that DOE would be obligated to repair and maintain its facilities at LANL, including TA-55, in a safe operating condition independent of the mission assignment for pit fabrication. LANL has existing capabilities that are essential to support other ongoing missions in addition to pit fabrication, such as the TA-55 capability for residue processing and for storing and handling plutonium. Although TA-55 facilities are being used to support LANL's pit fabrication mission, facility maintenance requirements exist independent of this mission assignment.

DOE included requirements and plans for refurbishing nuclear facilities at LANL as part of the No Action alternative in the SSM PEIS. In addition, this issue was addressed in the Final PEIS Comment Response Document [SSM PEIS, Vol. IV]. In response to a question of why DOE is investing in new facilities at LANL, DOE stated that "The TA-55 plutonium facility is approaching 20 years of service and many components of the facility need replacement or upgrading in order to sustain the R&D mission of the laboratory." [SSM PEIS Vol. IV, comment response 32.16, p. 3-84.] DOE further stated: "It is true that DOE has determined that, under the existing stockpile stewardship and management activities that have been ongoing for many years, facilities at LANL will have to be maintained and in some cases repaired or upgraded to allow LANL to continue to fulfill its existing mission. Far from being a 'stunning admission' that future assignments are already being implemented, DOE believes that is simply good management practice to keep its considerable real property -- its buildings and other infrastructure -- in safe, sound, and operating order." [SSM PEIS, Vol. II, comment response 40.90, p. 3-144.] DOE and LANL need to continue to operate TA-55 and PF-4 in a way that will allow the safe operation of the buildings to support nuclear materials processing operations for the indefinite, foreseeable future; one such use, but not the only such use, will be pit fabrication activities. In addition to the repairs and maintenance that would take place under the No Action baseline, the SSM PEIS acknowledged that upgrades to PF-4, TA-55 would be needed to implement the pit fabrication mission [SSM PEIS, Vol. I, Sec. 3.4.3.2, p. 3-58].

The SSM PEIS provided a programmatic review of the factors needed for the decisionmaker to discriminate between locating the pit fabrication activities at LANL or SRS. Under the two-phase NEPA strategy outlined in the SSM PEIS, project-specific decisions related to exactly how the programmatic decisions would be implemented at LANL would be covered in subsequent tiered NEPA reviews. Although the SSM PEIS indicated it assumed, as a No Action base case, that operating facilities at LANL and SRS would be kept in safe, environmentally compliant operating condition [SSM PEIS, Vol. II, Sec. A.1, p. A-1], it did not analyze at the site-specific level exactly how that would be accomplished. That level of detail would have been unnecessary, hence inappropriate, for a programmatic siting decision. Any future proposals to upgrade equipment or structures at TA-55 would be looked at to determine if they would be subject to NEPA review; any such review pertaining to pit fabrication would be considered a tiered review flowing from the SSM PEIS and ROD. This issue was also addressed in November 1997 as part of the court-ordered disclosure of information regarding pit production activities at LANL.

The Paine Affidavit makes reference to a newspaper article about the pit fabrication project (Paragraph 20, Attachment G), "LANL Plutonium Pit Project Plagued by Cost Overruns" [*Santa Fe New Mexican*, December 5, 1997, p. A-1, A.R. VII.B-44]. This article was based on a wide-ranging interview with the LANL pit fabrication program manager, and discussed the then-current status of the pit fabrication project. The article discussed cost overruns in the CMR Upgrades project. The situation regarding cost overruns in the CMR Upgrades project is addressed under DOE Issue 2, below. The article also referenced five upgrade alternatives; these are discussed

Supplement Analysis: Enhancement of Pit Manufacturing at LANL, SSM PEIS

below under Plaintiffs' Issue 5, Paine Affidavit Attachment J. The information referenced in the newspaper article does not constitute a substantial change to the programmatic proposal analyzed in the SSM PEIS.

This issue is not germane to a programmatic decision as to whether to site pit fabrication capabilities at LANL or SRS. Because it was understood in the SSM PEIS that facilities such as TA-55 needed to be kept in safe operating condition regardless of whether or not LANL received the pit fabrication mission, this issue does not present new information that was not available to the SSM decisionmaker. Even if a NEPA review would be required, it would be a tiered, project-specific review. Therefore, no change to the SSM PEIS is warranted.

(b) modernize the facilities and infrastructure of the TA-3 Sigma Complex for fabricating nonnuclear (e.g. beryllium, vanadium, uranium) pit components;

Nonnuclear weapons components such as those made from beryllium are an integral part of a pit, fabricating beryllium and other components was reassigned to LANL in 1993 prior to and independently of the pit fabrication mission assignment [SSM PEIS Vol. IV, comment response 32.08, p. 3-83]. In 1992 DOE decided to prepare an Environmental Assessment (EA) on its proposal to consolidate certain nonnuclear facilities within the nuclear weapons complex [57 FR 3046, January 27, 1992, A.R. No. VII.B-5], and completed the EA in June 1993 [DOE/EA-0792, A.R. No. III-85]. In this context, nonnuclear facilities are those which manufacture or test the nonnuclear parts of nuclear weapons. These parts include such things as electronics, batteries, detonators, and specifically include beryllium technology and pit support [Nonnuclear Consolidation EA Executive Summary, p. ES-1, DOE/EA-0792(ES), A.R. No. VII.B-9]. On September 14, 1993, DOE issued a Finding of No Significant Impact (FONSI) on the Nonnuclear Consolidation EA [58 FR 48043, A.R. No. VII.B-12] after considering public comments on a proposed FONSI [A.R. No. VII.B-11]. The then-proposed action included a proposal to enhance existing beryllium technology at LANL: "Beryllium Technology and Pit Support -- The existing technology base and prototyping capability at LANL would be enhanced to provide limited manufacturing capability for beryllium technology and pit support now done at RFP." [58 FR 48045.]

As soon as the FONSI was issued, DOE began to implement the proposed action [Letter from Howard Canter, Deputy Assistant Secretary for Weapons Complex Reconfiguration, to Interested Parties, September 24, 1993, A.R. No. VII.B-13]. The beryllium technology work from RFP was subsequently moved to the Sigma Complex at TA-3, LANL, to complement and enhance the prior existing capability.

The DOE's proposal to enhance the capability at the TA-3 Sigma Complex for beryllium technology and pit support functions was analyzed at length in the Nonnuclear Consolidation EA, June 1993, and discussed in its FONSI, September 1993. Implementation of this proposal began shortly after the FONSI was issued and included upgrades to Sigma Complex. Therefore, this decision did not have to be revisited in the SSM PEIS; since no decisions were needed on this aspect, no additional NEPA analysis was needed in the SSM PEIS.

This issue does not present new information that was not available to the SSM decisionmaker. Therefore, no change to the SSM PEIS is warranted.

(c) relocate selected environmentally sensitive nuclear materials missions from TA-55 to the aging CMR building to provide sufficient space for expanded pit manufacturing operations at TA-55, a decision that is now under active reconsideration and may be abandoned;

The SSM PEIS addressed the programmatic issues related to whether to site pit fabrication activities at LANL or SRS. The SSM PEIS stated that site-specific implementation of the programmatic decision would be addressed in subsequent tiered NEPA reviews [SSM PEIS, Vol. I, Sec. 1.5, p. 1-8]. The CMR Building is needed to support ongoing LANL work regardless of the assignment of the pit fabrication mission to LANL, and space allocations for assignment of work relating to nuclear materials may or may not be relevant to the pit fabrication mission. For pit fabrication, the specifics of exactly what processes would go in which building would be a site-specific detail of

Supplement Analysis: Enhancement of Pit Manufacturing at LANL, SSM PEIS

implementation beyond the intent of the SSM PEIS. A planning decision has not yet been made regarding whether to propose the use of the CMR building for missions relocated from TA-55, if, in fact, any activities are moved from TA-55. Potential environmental impacts for this scenario, if proposed, would be analyzed in project-specific NEPA reviews when appropriate. Alternatives to moving activities from TA-55 to CMR are anticipated to be addressed in the LANL SWEIS, including the potential for expanding TA-55. In the event that a decision that is made through a NEPA review is subsequently abandoned, additional NEPA review is not needed to address the agency's failure to take the action.

This issue does not present new information that is germane to a programmatic SSM decision. Therefore, no change to the SSM PEIS is warranted.

(d) add sufficient analytical chemistry capacity to the CMR facility to support increased pit production rates;

LANL has existing capabilities that are essential to support other ongoing missions in addition to pit fabrication including the capability for analytical chemistry in CMR. In 1997 DOE completed its EA on the proposed upgrades to the CMR Building [DOE/EA-1101, A.R. No. VII.B-27]. DOE found that no significant impacts would be expected to occur, therefore an EIS on that proposal was not needed [FONSI, February 11, 1997, A.R. No. VII.B-28]. The EA analyzed upgrades needed to make the building continue to be useable for the foreseeable future for continuing ongoing mission assignments. It specifically did not analyze upgrades needed to implement potential future new mission assignments. The CMR FONSI covered two potential upgrade designs for the CMR upgrades. Under the first, DOE would upgrade the chemistry space in three wings with collocated office space. Under the second, DOE would upgrade the chemistry space in two wings, relocate office space, and put the third wing in safe standby condition. The FONSI stated that if DOE selected the second design, and subsequently considered the space in the third wing for other programmatic needs, DOE would perform a separate NEPA analysis regarding any proposed new mission use.

DOE must maintain the nuclear infrastructure at LANL regardless of the pit fabrication mission in order to perform nuclear operations safely and reliably. Analytical chemistry is needed to support pit fabrication [SSM PEIS, Vol. I, Sec. 3.4.3.2, p. 3-58; Sec. 3.4.3.3, p. 3-64]. The SSM PEIS analyzed analytical chemistry as part of the infrastructure capability for each site (LANL and SRS) sufficient to support the pit capacities analyzed. The CMR building, built in the early 1950s, requires maintenance, repairs and upgrades to sustain the effectiveness and safety of the facility. These upgrades were addressed in the No Action Alternative in the SSM PEIS [SSM PEIS, Vol. IV, comment response 41.18, p. 3-158] and in the CMR EA and FONSI of February 1997. [See also the Declaration of Paul T. Cunningham, paragraphs 9 and 10, and the Second Declaration of Albert E. Whiteman, paragraph 5.d.1.]

There are no proposals to increase pit production rates over those analyzed in the SSM PEIS. Although at the request of Congress DOE and LANL have done some preliminary contingency planning as to how higher production rates might be achieved, if ever necessary, these considerations have not reached the state of an agency proposal, hence are not ripe for decision or NEPA review (see Plaintiffs' Issue 3, below).

This issue is based on incorrect information regarding rates of pit fabrication. The issue does not indicate that the analytical capability analyzed in the PEIS was incorrect. Therefore, no change to the SSM PEIS is warranted.

(e) establish a Special Nuclear Material Transportation Corridor between TA-55 and the CMR facility;

Although the idea of paving an existing, essentially abandoned, gravel road between TA-55 and the CMR Building at TA-3 has been discussed over the years, and may have some advantages for the safe, secure transport of nuclear materials between those two facilities, DOE has not yet formally proposed to undertake this action; however, it is

Supplement Analysis: Enhancement of Pit Manufacturing at LANL, SSM PEIS

anticipated that this may be included in the SWEIS as part of the consideration of a possible new transportation corridor between the two buildings.

This issue is not germane to a programmatic NEPA review since it is at the level of a minor site-specific infrastructure feature. While it may be a convenience in operating LANL facilities, it is not a necessary action for pit fabrication and does not bear on the programmatic decision to locate the pit fabrication mission at LANL. Therefore, no change to the SSM PEIS is warranted.

(f) renovate and make major modifications to the Nuclear Materials Storage Facility (NMSF) at TA-55 to accommodate increased plutonium inventory resulting from planned increase in pit surveillance and pit fabrication operations.

In 1986 DOE completed an EA and FONSI on the construction and operation of the then-new proposal for NMSF. [Memorandum, DOE/HQ, EH-1, Assistant Secretary Walker, to DOE/HQ, DP-1, Assistant Secretary Foley, August 28, 1986, A.R. VII.B-2; NMSF EA, A.R. No. VII.B-1, and FONSI, August, 1986, A.R. No. VII.B-2.] The operation of NMSF for its intended purpose was considered in the SSM PEIS as part of the No Action baseline and as a facility that could be used to support pit fabrication at LANL.

The NMSF was conceived in the early 1980's as a centralized facility at LANL for receipt and intermediate to long-term storage of special nuclear materials. Upon completion of construction of NMSF in 1987, DOE and LANL identified design and construction deficiencies in this facility which precluded the acceptance of the structure for occupancy; the introduction of nuclear materials into the NMSF was therefore not possible because it could not be used for its intended function and because health and safety operating parameters could not be met. In the early 1990's a series of studies was conducted to determine what needed to be done to bring the structure to an operable state. The repairs came to be known as the "NMSF Renovation Project." The NMSF renovations would allow the building to operate at its original design capacity (6.6 metric tons of plutonium) to support ongoing mission assignments at LANL, and were determined to be covered by the 1986 NMSF EA [Memorandum, Webb, DOE/LAEO, to Foyx, LANL, December 21, 1994, A.R. VII.B-17; covering memorandum, Reis, DOE/HQ/DP-1, to Manager, DOE/AL, November 9, 1994, A.R. No. VII.B-15; see also Ellard, LANL, May 14, 1993, A.R. No. VII.B-6, and Tingley et al., LANL, May 25, 1993, A.R. No. VII.B-7].

DOE is now renovating the facility to correct design and construction deficiencies in the structure, and damage and deterioration resulting from these deficiencies. Conceptual design for the NMSF renovations began in 1997, preliminary design began in 1998, final design is expected to start in the spring of 1999, construction is scheduled to begin in the summer of 2000, and the renovations are scheduled to be completed in 2004. The renovations will allow the facility to store up to 6.6 metric tons of plutonium, as was covered in the 1986 EA and FONSI. The facility will be used to support many on-going LANL mission requirements, including the SSM Program.

DOE plans to renovate the NMSF, as has been discussed since 1992, to correct design and construction deficiencies in the structure and damage and deterioration resulting from these deficiencies. However, the renovations would serve only to make the building functional in order to perform the activities discussed and analyzed in the 1986 NMSF EA and FONSI. The baseline used in the SSM PEIS for determining the impacts of reestablishing pit fabrication capability at LANL included making use of NMSF when functional (NMSF cannot be used to store nuclear materials until it becomes functional which would not be possible until renovation activities have taken place). The plans to renovate the NMSF were known to the SSM decisionmaker and do not constitute new information. There are no plans to store additional material in the NMSF over the amount considered at the time the SSM PEIS was prepared -- the NMSF will be renovated to accommodate storing 6.6 metric tons of plutonium, the same amount of material used as the basis of the analysis in the 1986 NMSF EA.

There are no proposals to increase pit production rates over those analyzed in the SSM PEIS. Although at the request of Congress DOE and LANL have done some preliminary contingency planning as to how higher

Supplement Analysis: Enhancement of Pit Manufacturing at LANL, SSM PEIS

production rates might be achieved, if ever necessary, these considerations have not reached the state of an agency proposal, hence are not ripe for decision or NEPA review (see Plaintiffs' Issue 3, below). There are no plans to increase pit surveillance over current projections (known to SSM decisionmakers) or to increase pit fabrication operations over the levels analyzed in the SSM PEIS.

This issue was earlier addressed in this litigation in the First Declaration of Albert E. Whiteman. He states that the NMSF renovation was considered in the baseline No Action alternative of the SSM PEIS, and that these "activities are necessary for ongoing stockpile stewardship and management independent of the determination made in the SSM-PEIS." [First Declaration of Albert E. Whiteman, p. 2. See also Declaration of Paul T. Cunningham, paragraph 11.]

This issue does not present new information that was not available to the SSM decisionmaker. The issue regarding increase in pit fabrication operations over that analyzed in the SSM PEIS is erroneous. Therefore, no change to the SSM PEIS is warranted.

3. Surge planning scenario. That the PEIS analysis is outdated because it did not analyze the reasonable foreseeable environmental impacts from DOE's approved surge planning scenario for fabricating up to 500 pits per year at multiple sites.

The SSM PEIS analysis of fabricating 20 to 50 pits per year, with 80 pits per year on a surge basis, was predicated on the need for new pits over the next 10 or more years. For comparison, the capacity of RFP when operating was about 2,000 pits per year [SSM PEIS Vol. IV, comment response 32.01, p. 3-80]; the SSM PEIS addressed reestablishing the former RFP capability but not its former capacity. DOE was aware at the time the PEIS was prepared that future requirements for capacity for pit fabrication were uncertain [SSM PEIS Vol. I, Sec. 3.6, p. 3-93]. In the SSM PEIS Comment Response Document, DOE stated: "Because of the small demand for the fabrication of replacement plutonium pits over the next 10 or more years, DOE did not propose a new pit fabrication facility with a capacity equivalent to the capacities required for other portions for the nuclear weapons complex. However, limited fabrication of new replacement pits would be required to maintain capability and to replace pits lost during weapons surveillance. Section 3.6 discusses DOE's future plans should a life-limited phenomenon be found in stockpile pits and a larger pit fabrication capacity be required." [SSM PEIS Vol. IV, comment response 40.19, p. 3-107.] The SSM ROD indicated that if a greater capacity for pit fabrication were to be needed in the future, appropriate environmental and siting analyses would be performed at that time [SSM ROD Supplementary Information; Sec. 3.A.4]. To date, the nation has not determined future stockpile rates to be greater than anticipated in the SSM PEIS, and DOE has no proposals at this time to establish a greater pit fabrication capacity within its planned capability.

Part of the assignment given to LANL by the SSM ROD was to assist DOE in developing equipment and technologies to expand the limited capability assigned in 1996 to LANL into a larger capability that might be needed by DOE at some site at some point in the future. This did not imply that such an expanded capacity, if ever needed, would be located at LANL; instead, the SSM ROD stated that in this event, environmental and siting studies would be performed [SSM ROD 3.A.4].

The Paine Affidavit makes reference to LANL's Institutional Plan for FY 1998 - 2003 (Paragraph 21, Attachment H). The "Institutional Plan FY 1998 - FY 2003" [LALP-97-130, October 1997, A.R. No. VII.B-40], in turn, makes reference to a multi-site study and the consideration of a modular production capability that could be deployed rapidly if there was a change from the requirements considered in the SSM PEIS and ROD [LALP-97-130, p. 28]. In February 1996 DOE formed an *inter-site team* which was asked to develop a plan which would provide a strategy to establish a project in FY00 which would be responsible for developing a means to achieve a higher pit production capacity within five years of an identified need [Memorandum, February 21, 1996, Whiteman to Veldman, et al., A.R. No. VII.B-22; Attachment, "Rapid Reconstitution of Pit Production Capacity," February 20, 1996, Khalil, DOE AL, A.R. No. VII.B-21]. The memorandum stated that the project needed to

Supplement Analysis: Enhancement of Pit Manufacturing at LANL, SSM PEIS

provide a scalable capacity, and would require development and technology demonstration; the SSM ROD subsequently recognized this: "DOE will perform development and demonstration work at its operating plutonium facilities over the next several years to study alternative facility concepts for a larger capacity." [SSM ROD, Sec. 3.A.4.] This memorandum predated the SSM PEIS and was known to the SSM decisionmaker. In August 1997 the inter-site team completed its report, "Rapid Reconstitution of Pit Production Capacity: Systems Studies Assessment and Recommendations" [LLNL UCRL-ID-128655, Jardine, LLNL, Reardon, LANL, and Grimley and Branstetter, Sandia National Laboratories, August 1997, A.R. No. VII.B-36]. This document is subject to controlled distribution because it contains Unclassified Controlled Nuclear Information (UCNI) material. The strategy responds to the 1996 memorandum charge to be able to establish a greater capacity within five years of an identified need. The SSM ROD stated that in the event a larger capacity were ever needed, appropriate siting and environmental reviews would be performed at that time [SSM ROD, Sec. 3.A.4]. While the August 1997 report was completed after the SSM ROD was issued, it addressed a topic that the SSM ROD specifically excluded as a reasonably foreseeable action requiring a programmatic decision at that time. Therefore neither the LANL Institutional Plan nor the 1997 rapid reconstitution plan present new information that would bear on the SSM ROD decisions to site pit manufacturing capacity at LANL.

As part of prudent planning to support and maintain the directed stockpile levels in the event of an unforeseen future issue that could affect national security, at the request of Congress in FY96 DOE began work on a preliminary contingency plan that could put into place a production capability of up to 500 pits per year. In the National Defense Authorization Act for Fiscal Year 1997, P.L. 104-201, Section 3151, Congress required the Secretary of Energy to submit to Congress a report on DOE's plans for achieving the capability to produce and remanufacture plutonium pits. In response to that requirement, DOE prepared the "Department of Energy Report on Plutonium Pit Production and Remanufacturing Plans" [Letter, Secretary Peña to Congressman Floyd Spence, Chairman, Committee on National Security, U.S. House of Representatives, August 18, 1997, covering "Department of Energy Report on Plutonium Pit Production and Remanufacturing Plans, Secretary of Energy, July 1997," A.R. No. VII.B-37]. The report provided Congress with DOE's initial baseline plan to restore the capability to produce pits for the nuclear weapons stockpile (war-reserve pits). The baseline consisted of three parts: (a) demonstrate that the capability to produce war-reserve pits can be reestablished at LANL; (b) install a limited capacity at LANL to produce up to 50 war-reserve pits; and (c) develop a contingency plan to establish capacity to produce up to 500 war-reserve pits, using LANL technology as a model, at existing DOE buildings at SRS, DOE's Oak Ridge Reservation, DOE's Pantex Plant, and DOE's Nevada Test Site [Report, p. 2]. The number 500 was used for planning purposes because it represented a rate which could reproduce a large quantity "lot" within a reasonable timeframe, and because it was felt to be achievable by replicating multiple setups of the type that are being put into place at LANL. [See also A.R. No. VII.B-42.] No specific requirements for an upper capacity number have yet been developed. This preliminary plan, which has never progressed beyond its very early stages, is currently on hold pending development and evaluation of the design, processes, equipment, and feasibility of the current ongoing pit rebuild program at LANL. As stated in the SSM ROD, any decisions to pursue an expanded capacity in the future, including siting decisions, would be subject to further NEPA review [SSM PEIS, Vol. 1, Sec. 1.5, p. 1-8].

The SSM PEIS and ROD acknowledged that future needs for pit fabrication capacity are unknown, and that future plans for future capacities will be subject to future NEPA review. The contingency plan requested by Congress, which has had some preliminary work, is not fully developed and is not expected to be fully developed for quite some time. Therefore it does not represent a proposal within the meaning of NEPA, and is not ripe for analysis or decision.

This issue does not present new information that is germane to the programmatic decisions in the SSM ROD. It raises an issue that is not yet ripe for NEPA review. Therefore, no change to the SSM PEIS is warranted.

Supplement Analysis: Enhancement of Pit Manufacturing at LANL, SSM PEIS

4. DNFSB safety consideration. That the PEIS inadequately considered safety consideration associated with the CMR Building, identified in part in a December 1997 DNFSB report to DOE.

The DNFSB, established in 1988, has certain oversight responsibilities for nuclear facilities at LANL, such as TA-55 or CMR. Under its enabling statute [42 USC 2286] DNFSB is responsible for independent, external oversight of all activities in DOE's nuclear weapons complex affecting health and safety. The DNFSB reviews operations, practices, and occurrences at DOE's defense nuclear facilities and recommends actions to the Secretary of Energy to protect public health and safety. As such, the DNFSB assists DOE in its continuous efforts to control risks associated with its operations and to continually improve its performance. This aspect of site management is an integral component of continuing operations at all DOE sites, including LANL.

In July 1997 LANL provided DOE and the DNFSB with a copy of the draft "Enhanced Conceptual Design Report (ECDR) for the Capability Maintenance and Improvement Project (CMIP)" referenced in Paragraph 23 of the Paine Affidavit. The DNFSB conducted an on-site review of the draft ECDR in September 1997. The DNFSB letter of December 5, 1997, referenced in Paragraph 23 of the Paine Affidavit as Attachment I [A.R. No. VII.B-45], provided input to DOE and LANL on the draft ECDR. Completion of the draft ECDR is currently on hold due to project changes and funding considerations. DOE recently approved a modified approach to implementing CMIP [Memorandum, January 12, 1998, Whiteman to Cunningham, A.R. No. VII.B-50] (see DOE Issue 1), and the draft ECDR will be revised to accommodate the modified strategy. Given current funding and schedule considerations, LANL does not expect to resume work on the draft ECDR until FY99, with FY00 as the earliest completion date.

The issues raised by the DNFSB in its December 1997 letter are management and process issues consistent with the charter of that Board. While it is possible that future DOE initiatives associated with correcting the problems noted by the DNFSB could be subject to future NEPA reviews, no such proposals have yet been made. Furthermore, the management and process issues raised by the DNFSB do not affect the programmatic question of assignment of the pit production mission to either LANL or SRS addressed in the SSM ROD. Any proposals resulting from these issues will be appropriately addressed by further, facility-specific NEPA reviews.

CMR project management and operational considerations are discussed under DOE Issues 2 and 3. Construction of the CMR Upgrades project was temporarily suspended in the spring of 1997 pending review and implementation of better project management controls. That work was completed and construction restarted in the summer of 1997. Project management considerations of the Upgrades Project, CMR operations safety reviews and organizational changes are unrelated to NEPA reviews. In the fall of 1997 in response to safety considerations, LANL temporarily suspended operations within the CMR building pending an in-depth review of all CMR operations. Operations were resumed over time in a phased manner as work control and work authorization procedures were verified for each on-going project within the building; most operations have resumed. In November 1997, LANL received a new Director; in January 1998 the Director reorganized the management structure for operating the CMR Building and its ongoing operations. Budgeting, establishing project management controls, temporary suspension of work to review operational safety, and establishing management organizations would not be subject to NEPA. While it is possible that certain activities taken to improve operational safety may be subject to NEPA, any such action pertaining to implementing pit fabrication activities at LANL would be of a facility-specific nature; in other words, would be tiered from programmatic decisions established in the SSM ROD.

The DNFSB letter of December 5, 1997 also mentioned earthquake faults in the vicinity of TA-3 and the CMR Building; this is discussed under DOE Issue 4. In 1997, LANL geologists initiated a study of the interrelationship of three known geologic faults (Pajarito, Guaje Mountain, and Rendija Canyon faults) in the vicinity of LANL. The preliminary results of that draft study were presented to DOE management [Memorandum, October 28, 1997, Ives, DOE/HQ. to Manager, DOE AL, A.R. No. VII.B-41; Memorandum, Senazi to Trapp, November 13, 1997, A.R. No. VII.B-43; Attachment 1: memorandum, Ives to Manager, October 28, 1997, A.R. No. VII.B-41]. The results to date indicate a possible connection between the three faults, which would increase the likelihood of geologic rupture should a seismic event occur. This could indicate that some buildings in TA-3 might be

Supplement Analysis: Enhancement of Pit Manufacturing at LANL, SSM PEIS

vulnerable to damage if certain seismic events occurred. DOE requires its sites to review seismic information at about ten year intervals to determine if there is any new information that would result in revising site management actions [DOE Order 420.1, Facility Safety, Sec. 4.4, Natural Phenomena Hazards Mitigation]; LANL has been performing site studies for several years in response to this requirement. Additionally, DOE is conducting an agency-wide review of seismic safety at all of its facilities in response to EO 12941, "Seismic Safety of Existing Federally Owned or Leased Buildings" [59 FR 62545, A.R. No. VII.B-16], and a related DOE implementing guidance memorandum of October 18, 1996 from the Assistant Secretary for Environment, Safety and Health. This report is due to the Federal Emergency Management Administration by December 1, 1998, and has not yet been issued.

The preliminary studies and draft reports indicate the need to consider revising building engineering standards at LANL [Memorandum, Ives to Manager, October 28, 1997, A.R. No. VII.B-41]. The LANL seismic studies do not indicate that the probability of an earthquake event is any more likely than previously thought; the SSM PEIS discussed the known moderate seismic risk at LANL and the possibility of a seismic event as an accident initiator [SSM PEIS, Vol. I, Sec. 4.6.3.5, p. 4-288; Vol. II, Appendix F, Sec. F.2.3.1, p. F-21, F-22; see also SSM PEIS Vol. I, Glossary, definition of "capable fault," p. 9-3]. These studies indicate, however, that DOE, LANL and safety agencies must come to agreement on the amount of seismic protection needed for new and retrofitted buildings at LANL.

Construction of structural modifications such as installing additional seismic bracing would be subject to a NEPA review; this type of facility-specific review if pertaining to implementing pit fabrication decisions would be tiered from programmatic decisions established in the SSM ROD.

While the incidents and studies pointed out in this issue postdate issuance of the SSM PEIS and SSM ROD, actions pertaining solely to budgeting, project management, personnel reorganizations, and developing design standards would not be subject to NEPA. Implementing specific actions pertaining to operational safety or seismic upgrades may be subject to NEPA; however, these would be project-specific NEPA reviews tiered from the SSM analysis, if applicable, and are not germane to programmatic decisions regarding locating the pit fabrication mission.

5. Accidents involving Pu-238. That the PEIS omitted any analysis of accident consequences involving release of Pu-238, where information indicates that two-thirds of the PF-4 space at TA-55 slated for processing Pu-238 would be located in the same building as pit fabrication activities.

The Paine Affidavit, Paragraph 24, refers to alleged new information, Attachment J, that is claimed to shed new light on the accident consequences of processing Pu-238 at TA-55, PF-4. Following completion of the SSM PEIS and assignment of pit fabrication to LANL in the SSM ROD, as part of its site-specific studies to develop an approach to implementing the pit fabrication mission, LANL considered various alternative ways to allocate office and laboratory space at TA-55 and CMR among the various ongoing and newly-assigned missions. The results of that feasibility study were documented in "Alternative for Increasing the Nuclear Materials Processing Space at Los Alamos for Future Missions" [LA-UR-97-1000, April 25, 1997, A.R. No. VII.B-30], which was included as Attachment J to the Paine Affidavit. The feasibility study included, as introductory material in the section cited by Plaintiffs, a summary of the different then-current missions and then-existing space allocations in TA-55. This summary information on mission assignments was not new, and, as explained below, was available to the SSM decisionmaker at the time the SSM ROD was prepared. The feasibility study was included as an attachment to the draft ECDR sent in July 1997 to DOE and DNFSB; the ECDR has not yet been finalized.

LANL carries out Pu-238 operations in TA-55, PF-4, including the manufacture of Pu-238 heat sources for the National Aeronautics and Space Administration (NASA) deep space missions, and has done so for many years under projects such as the Cassini Project ["Environmental Assessment for Radioisotopic Heat Source Fuel Processing and Fabrication," DOE Offices of Special Applications, Assistant Secretary for Space and Defense Energy Systems, DOE/EA-0534, A.R. No. VII.B-3; FONSI 56 FR 34057, July 25, 1991, A.R. No. VII.B-4; "EIS

Supplement Analysis: Enhancement of Pit Manufacturing at LANL, SSM PEIS

for the Cassini Mission," Solar System Exploration Division, Office of Space Science, NASA, June 1995, A.R. No. VII.B-19; see also Final Supplemental EIS for the Cassini Mission, NASA, June 1997, A.R. No. VII.B-32]. The use of plutonium laboratory floor space at TA-55, PF-4 for Pu-238 work associated with the Cassini mission, including the consequences of release of radiological materials under normal or accident conditions, was specifically assessed in the 1991 EA [DOE/EA-0534, Sec. 4.2.1, p. 4-3; Sec. 6.2.1.2, p. 6-3; Sec. 6.2.2, p. 6-4; FONSI 56 FR 34059]; DOE subsequently implemented this work essentially as described in the EA except that the period of operations for the Cassini project extended until 1996 instead of 1994 as projected in the 1991 EA due to overall project delays. The information regarding collocation of Pu-238 work with other Pu work at TA-55, PF-4, has been in the public venue since mid-1991 and does not represent "new information."

The cumulative radiological impacts of collocating Cassini work and pit processing was mentioned in the SSM PEIS [SSM PEIS, Vol. IV, comment response 11.07]. LANL has always had a limited capacity to manufacture pits [see, for example, SSM PEIS, Vol. IV, response to comment summary 32.12, p. 3-84; and reply to Question 15a from the NRDC questions "Pit Production at Los Alamos: Questions Concerning Environment, Safety and Health Issues," November 1997]. The ongoing mix of plutonium operations at TA-55, which include among other things the current pit fabrication work, Pu-238 operations, and plutonium research and development to support LANL's national security and environmental management missions, was included in the No Action Alternative in the SSM PEIS; the pit production mission is not expected to result in any changes to the PF-4 areas involved in Pu-238 work. DOE continues to conduct these ongoing activities and has in place procedures to assure that new activities will be subject to rigorous safety reviews (which among other things assess the risk of collocating new activities with ongoing operations) before any new activities would be allowed to begin. Therefore, information regarding the collocation of ongoing Pu-238 activities and proposed pit fabrication activities was available to the SSM decisionmaker at the time the SSM ROD was issued. The SSM PEIS provided a programmatic analysis to compare impacts of pit fabrication that would be expected if located at LANL or SRS; it was intended that site-specific impacts of implementing programmatic mission assignments (including the cumulative effects of collocated missions at TA-55) would be analyzed in subsequent tiered NEPA documentation [SSM PEIS, Vol. I, Sec. 1.5, p. 1-8].

The accident analyses of the SSM PEIS were explained in detail in Appendix F, which stated that the issues regarding health risks were twofold: to determine whether accidents at specific facilities would pose unacceptable risks; and which alternative locations would provide an advantage of lesser risk [SSM PEIS, Vol. II, Sec. F.1.1, p. F-1]. The SSM PEIS also acknowledged that specifics regarding measures to reduce risk would be contained in subsequent tiered NEPA reviews, project-specific design reviews, and facility-specific safety analysis reports [SSM PEIS, Sec. F.1.1, p. F-2]. The source documents reviewed [SSM PEIS, Vol. II, Table F.1.1-1] made reference to the presence of Pu-238 at TA-55. The SSM PEIS provides a bounding accident analysis and compares the potential health effects from different accident scenarios at LANL and SRS [SSM PEIS, Vol. II, Sec. F.2.3, p. F-16]. [See also SSM PEIS Vol. IV, response to comment 11.08, p. 3-107; and 11.42, p. 3-54.]

The decisionmaker had relevant information available regarding the comparative risk of placing pit fabrication activities at LANL or SRS (including that of collocating pit fabrications activities in the same building as Pu-238 activities), and whether or not the accident risk at any given facility was unacceptable. DOE is obligated to operate TA-55 at LANL in a safe operating configuration (including ongoing activities with Pu-238) regardless of the incremental effect of placing pit fabrication activities at that facility. The decisionmaker knew that Pu-238 activities take place at TA-55, and the decisionmaker weighed whether or not the incremental addition of adding pit fabrication operations to TA-55 posed an unacceptable risk.

This issue was addressed previously in this litigation in the Second Declaration of Albert E. Whiteman. He stated that it has always been acknowledged that Pu-238 operations are carried out in TA-55 PF-4, and are addressed in the TA-55 Safety Analysis Report, A.R. No. I-1124, I-1125 [Second Declaration of Albert E. Whiteman, p. 28]. He stated Pu-238 processes are housed in the north half of PF-4 while pit manufacturing processes are housed in the south half, and discusses safety and accident considerations [Second Declaration, p. 28, 29].

Supplement Analysis: Enhancement of Pit Manufacturing at LANL, SSM PEIS

This issue does not present new information that was not available to the SSM decisionmaker. Therefore, no change to the SSM PEIS is warranted.

Analysis of Issues Raised by DOE

1. Pit production strategy.

In September 1997 DOE initiated an evaluation of the potential for fabricating pits in the near-term without displacing other ongoing activities in TA-55. A modified strategy was approved by DOE HQ in December 1997 and transmitted from DOE AL to LANL in January 1998. The strategy in general addressed engineering project management, scheduling, and logistics issues. CMR and Sigma facilities would continue to support pit production. [Memorandum, Whiteman to Cunningham, January 12, 1998, A.R. No. VII.B-50; Attachment 1: memorandum, Ives to Twining, December 16, 1997, A.R. No. VII.B-46; Attachment 2: "Pit Production -- Baseline Program and Project Requirements and Assumptions."]

The three objectives of the modified strategy are:

- (a) Decouple the CMIP project for pit fabrication from other projects and focus development of pit production capability at TA-55 without disrupting ongoing mission.
- (b) Maintain pit production as a continuous process, and achieve an intermediate capacity of 20 pits per year by FY 2007 without prejudice to the eventual 50 pit per year capacity.
- (c) Delay CMIP while performing urgent maintenance and equipment replacement beginning in FY 1999.

The modified strategy in general addresses engineering project management, scheduling, and logistics issues. These types of issues do not result in environmental impacts other than those from implementing the proposed actions, and are generally irrelevant to a NEPA review. The site-specific implementation of CMIP would be subject to project-specific NEPA review. DOE anticipates that the site-specific environmental impacts of implementing the CMIP project will be contained in the LANL SWEIS now under preparation.

The SSM PEIS acknowledged DOE's intent to further refine its plans to implement its programmatic decisions; the SSM PEIS and ROD discussed the two-tiered NEPA strategy and indicated that project-specific decisions on how to implement programmatic decisions would be analyzed in subsequent, tiered, NEPA reviews. DOE is now in the process of refining its plans for implementing the new pit fabrication mission at LANL, and at the same time continuing to carry out its prior pit fabrication missions.

Under the modified strategy, CMR and Sigma facilities would continue to support pit production. The use of these two facilities to support pit production was discussed in the SSM PEIS. As discussed above, the use of Sigma to manufacture nonnuclear pit components was analyzed by DOE in the Nonnuclear Consolidation EA, June 1993, and its related FONSI, September 1993. Implementation of that proposed action began in 1993.

Decoupling the CMIP project from other ongoing construction projects at LANL facilities is a project management (paperwork) activity that would not in itself result in additional environmental impacts. In any case, the CMIP project represents site-specific implementation of programmatic SSM decisions; in accordance with the SSM PEIS and ROD, site-specific implementation would be subject to subsequent, tiered NEPA review.

Maintaining pit production as a continuous process is a project management aspect of implementing this proposal. The comparison of environmental impacts, if any, from differential schedules for implementing pit production would be captured in the project-specific NEPA review for CMIP or its follow-on activities.

Supplement Analysis: Enhancement of Pit Manufacturing at LANL, SSM PEIS

At the same time that they were considering implementation needs for CMIP, DOE and LANL considered the need to expedite certain planned activities at TA-55 so that they would occur prior to CMIP. These are maintenance actions and equipment upgrades that would be needed to conduct LANL's defense mission at TA-55 independent of the pit fabrication mission. Maintenance actions and upgrades to existing equipment at TA-55 would be subject to project-specific NEPA review; the LANL SWEIS is anticipated to consider the cumulative impacts of operating TA-55 under different scenarios, and additional project-specific NEPA review may be needed for any proposed equipment upgrades at the time they are ripe for decision.

The modified strategy for implementing the pit fabrication mission at LANL, as captured in the CMIP project modifications, would be details of site-specific implementation that would not be germane to a programmatic decision to locate this mission. Because it was understood in the SSM PEIS that facilities such as TA-55 needed to be kept in safe operating condition regardless of whether or not LANL received the pit fabrication mission, this issue does not present new information that would bear on the programmatic pit fabrication siting decision. Tiered, project-specific NEPA reviews are planned to cover the CMIP project and improvements to related facilities. Therefore, no change to the SSM PEIS is warranted.

2. CMR project management considerations.

In the SSM PEIS, DOE acknowledged that it could not eliminate any of its weapons manufacturing and component surveillance capabilities [SSM PEIS, Vol. I, Sec. 2.4.2, p. 2-8], and would continue to need all the basic capabilities of its industrial and laboratory base regardless of its decisions to reestablish pit manufacturing capability [SSM PEIS, Vol. I, Sec 2.5, p. 2-10]. The need for analytical chemistry as part of the pit fabrication mission was described in Appendix A [SSM PEIS, Vol. II, Sec. A.3.3, p. A-117, and Figure A.3.3-1, p. A-118]. DOE also acknowledged that its SSM Program would continue to evolve as better information became available and technological advancements occur, and that these future advancements would be subject to future NEPA reviews [SSM PEIS, Vol. I, Sec. 2.5.1, p. 2-10]. One of the ongoing capabilities DOE continues to need in support of its nuclear weapons mission, and independently of any decision to site pit fabrication capabilities, is its analytical chemistry capability at CMR.

Over the past several years, and independent of the need to reestablish pit fabrication, DOE has planned to upgrade the CMR building to extend its useful life to meet ongoing LANL mission requirements. DOE prepared the CMR Upgrades EA [DOE/EA-1101, A.R. No. VII.B-27] and reached a FONSI for the proposed upgrades on February 11, 1997 [A.R. No. VII.B.28]. DOE and LANL immediately began to implement those proposed actions in a sequential manner. LANL was tasked with carrying out certain project management assignments to facilitate design and construction of the upgrades project. In early 1997 it became apparent that costs of the ongoing CMR upgrades project would, unless checked, overrun the FY97 budget. After considering budget, schedules and project management issues, DOE and LANL decided to temporarily suspend construction activities for the CMR upgrades project pending a thorough budget and project management review. [Memorandum, Cunningham to Whiteman, April 24, 1997, A.R. No. VII.B-29; memorandum, Whiteman to Cunningham, May 5, 1997, A.R. No. VII.B-31; letter, Reis to Senator Thurmond, June 19, 1997, A.R. No. VII.B-33; letter, Reis to Senator Domenici, June 19, 1997, A.R. No. VII.B-34. See also Second Declaration of Albert E. Whiteman, June 6, 1997, paragraph 4.g. (p. 8).] Following that review, the upgrades project resumed and upgrade construction activities are underway.

NEPA is a forecasting tool that projects the anticipated environmental impacts that would occur if proposed actions were implemented. The SSM PEIS projected the expected impacts if the pit fabrication mission were to be located at LANL, including use of the CMR Building to support that assignment. The CMR EA analyzed the impacts from constructing the CMR upgrades and the impacts of operating the upgraded CMR Building. The projection and analysis of potential environmental impacts is not dependent on project management considerations such as design and engineering costs, schedules, and skill. These are irrelevant to a NEPA analysis, although they are of interest for other reasons.

Supplement Analysis: Enhancement of Pit Manufacturing at LANL, SSM PEIS

This issue raises new information, but not information that is germane to a NEPA review. Therefore, there is no need to supplement the existing NEPA reviews on the CMR upgrades project. The need for the CMR upgrades project is independent of the decision to reestablish pit fabrication at LANL. Therefore, the consideration of the adequacy of the site-specific review of the CMR upgrades project is irrelevant to the programmatic decisions in the SSM PEIS, and does not represent a substantial change to the proposal analyzed in the SSM PEIS. Accordingly, no change to the SSM PEIS is warranted.

3. CMR safety reviews and organizational changes.

On September 2, 1997, in response to safety considerations, LANL temporarily suspended operations within the CMR building pending an in-depth review of all operations and procedures being implemented within the building to support on-going LANL missions. Operations were resumed over time in a phased manner as work control and work authorization procedures were verified for each on-going project within the building. [Memorandum, Gancartz to All CMR Occupants, September 2, 1997, A.R. No. VII.B-38; memorandum, Jackson to Todd, September 5, 1997, A.R. No. VII.B-39.] To further improve operation of the CMR facility within a safe operating envelope for nuclear facilities, LANL Director Browne announced a new integrated management organization for CMR in which the technical, operations, and facility management of CMR would be integrated with that of TA-55. This reorganization became effective in January 1998. [E-mail memorandum, Browne to managers, December 17, 1997, A.R. No. VII.B-47; memorandum, Reis to All CMR and TA-55 Employees, December 19, 1997, A.R. No. VII.B-48; electronic LANL Newsbulletin, "News from John Browne, CMR and TA-55 Integration," January 7, 1998, A.R. No. VII.B-49.]

DOE needs to continue to operate CMR and its other nuclear facilities in a safe, secure manner in order to be able to perform its mission assignments. Operation and management of the CMR Facility is, to some extent, delegated to LANL under its management and operating contract with the DOE. Therefore, it is incumbent upon LANL managers to take actions they deem necessary to ensure that LANL facilities are operated safely and in compliance with operating authorizations.

Management actions such as facility organizational arrangements do not generally, in and of themselves, result in environmental impacts other than those of carrying out the work of the facility. The management actions taken to improve operations at the CMR Building present new information, but not information that is germane to a NEPA review. Consideration of improvements to the management structure at CMR would be a site-specific detail of implementing programmatic mission assignments from the SSM ROD. Therefore, no change to the SSM PEIS is warranted.

4. New earthquake faulting studies at LANL.

As discussed in Plaintiffs' Issue 4 above (consideration of the DNFSB safety concerns), in 1997, LANL geologists initiated a study of the interrelationship of three known geologic faults (Pajarito, Guaje Mountain, and Rendija Canyon faults) in the vicinity of LANL. The preliminary results of that draft study were presented to DOE management [Memorandum, October 28, 1997, Ives, DOE/HQ, to Manager, DOE AL, A.R. No. VII.B-41; Memorandum, Senazi to Trapp, November 13, 1997, A.R. No. VII.B-43; Attachment 1: memorandum, Ives to Manager, October 28, 1997, A.R. No. VII.B-41]. The results to date indicate a possible connection between the three faults, which would increase the likelihood of geologic rupture should a seismic event occur. This could indicate that many buildings in TA-3 would be vulnerable to damage if a seismic event occurred. DOE requires its sites to review seismic information at about ten year intervals to determine if there is any new information that would result in revising site management actions [DOE Order 420.1, Facility Safety, Sec. 4.4, Natural Phenomena Hazards Mitigation]; LANL has been performing site studies for several years in response to this requirement. Additionally, DOE is conducting an agency-wide review of seismic safety at all of its facilities in response to EO 12941, "Seismic Safety of Existing Federally Owned or Leased Buildings" [59 FR 62545, A.R. No. VII.B-16], and a related DOE implementing guidance memorandum of October 18, 1996 from the Assistant Secretary for

Supplement Analysis: Enhancement of Pit Manufacturing at LANL, SSM PEIS

Environment, Safety and Health. This report is due to the Federal Emergency Management Administration by December 1, 1998, and has not yet been issued.

The results of the preliminary studies and draft reports suggest that some LANL buildings could be vulnerable to damage in the event of certain seismic events. These studies indicate the need to consider revising building engineering standards at LANL. Promulgating design standards would not be subject to NEPA review, although implementation of any such standards may be. The LANL seismic studies do not indicate that the probability of an earthquake event is any more likely than previously thought; the SSM PEIS discussed the known moderate seismic risk at LANL [SSM PEIS, Vol. I, Sec. 4.6.3.5, p. 4-288; Vol. II, Appendix F, Sec. F.2.3.1, p. F-21, F-22; see also SSM PEIS Vol. I, Glossary, definition of "capable fault," p. 9-3]. These studies indicate, however, that DOE, LANL and safety agencies must come to agreement on the amount of seismic protection needed for new and retrofitted buildings at LANL.

The SSM PEIS considered release of radioactive materials in a seismic accident event and this information was considered by the decisionmaker when deciding to site the pit fabrication mission at LANL. While new seismic studies now underway appear to indicate that there is a need to invest in greater seismic retrofitting to protect building infrastructure, these new studies do not indicate that there would be a greater frequency of seismic events. If new standards are promulgated, buildings at LANL would need to be retrofitted to ensure continuation of safe secure operations to perform ongoing mission requirements regardless of the decision to site the pit fabrication mission at LANL.

The SSM PEIS analyzed the safety and health impacts if a seismic event occurred (regardless of the projected likelihood of this event occurring) and massive structural damage resulted in a release of radioactive materials. The new studies ongoing at LANL do not indicate any preliminary information that would result in a change to the accident analysis presented in the SSM PEIS. Construction activities related to structural modifications would be site-specific actions irrelevant to the programmatic questions considered in the SSM PEIS. Therefore no change to the SSM PEIS is warranted.

CONCLUSIONS**These Issues Do Not Change the SSM PEIS Analysis**

The nine issues considered in this Supplement Analysis were either covered in the SSM PEIS and so were available to the decisionmaker; were project-specific issues related to the implementation of SSM decisions at LANL and so would be subject to subsequent tiered NEPA review and decisionmaking; or were preliminary information and so would be subject to future review at such time as they are ripe for decision. Therefore, none of these issues would result in a need to change the SSM PEIS analysis of pit fabrication.

These Issues Do Not Change the SSM ROD

The SSM ROD was based in part on the environmental analysis in the SSM PEIS and in part on other factors. None of the issues raised in the Paine Affidavit, or in the related information considered by DOE, bring forth salient new information bearing on programmatic decisions for siting the reestablished pit fabrication mission of which the decisionmaker was unaware at the time the SSM ROD was issued. Therefore, none of these issues would result in a need to change or amend the programmatic SSM ROD.

Supplement Analysis: Enhancement of Pit Manufacturing at LANL, SSM PEIS

RECOMMENDATIONS

Based on the analysis of the issues raised by plaintiff in the Paine Affidavit, DOE does not see any need to supplement the SSM PEIS analysis of reestablishing the former RFP pit fabrication mission at LANL to provide an enhanced pit manufacturing capability. DOE does not believe that any new proposals have emerged which would require preparation of a new EIS at this time. DOE recommends that the SSM PEIS analysis of reestablishing pit fabrication at LANL be left standing and that no additional NEPA reviews, apart from those already planned in the LANL SWEIS or elsewhere, be initiated at this time.

Date: 3/17/98

Approved

Disapproved



Victor H. Reis, Assistant Secretary for Defense Programs

APPENDIX I
REPORT ON THE STATUS AND IMPLICATIONS OF
SEISMIC HAZARD STUDIES AT LANL

United States Government

Department of Energy

Albuquerque Operations Office

memorandum

DATE: JAN 08 1999

REPLY TO: NPD

SUBJECT: Status and Implications of Seismic Hazard Studies at LANL

TO: W. Scott Gibbs, Program Director, MMP, LANL, MS A102

We have reviewed the subject LANL report (dated December 17, 1998), and concur with the conclusions reached regarding the implications of this series of seismic studies. The information summarized in this report and discussed in more detail in the five seismic studies that have been completed, to date, are and will continue to be considered in the execution of mission work at LANL. A specific example of this is the recently approved Interim Technical Safety Requirements for operations at the Chemistry and Metallurgy Research (CMR) Building, which includes reductions in material at risk in that facility and plans for containerization of material in glovebox lines which is not actively being used; these actions are taken to reduce the potential consequences of seismically-initiated accidents in the CMR Building. DOE will continue to examine the mission work at LANL in consideration of seismic and other risks to ensure that such work can be accomplished within acceptable levels of risk.

Should you have any questions on this matter, please contact me (845-6038) or Mr. Corey Cruz (845-6736) of my staff.



A. E. Whiteman
Assistant Manager for
Technology and Site Programs

cc:

E. Ives, DP-20, FORS, HQ
J. Ordaz, DP-13, GTN, HQ
J. Kimball, DP-45, GTN, HQ
L. Goen, LANL, MS P946

Los Alamos National Laboratory

*Nuclear Weapons
Materials and Manufacturing(NW-M&M)
Program Office*
P.O. Box 1663, Mail Stop A102
Los Alamos, New Mexico 87545
(505) 667-9807 / FAX: (505) 665-1812

Date: December 22, 1998
Refer to: NW/M&M:98-20

Mr. Edwin E. Ives
Technical Director
DP-20, FORS
U.S. Department of Energy
1000 Independence Avenue, S.W.
Washington, DC 20585

Mr. A. Earl Whiteman
Assistant Manager
Technology and Site Programs
U.S. Department of Energy
Albuquerque Operations Office
P.O. Box 5400
Albuquerque, NM 87185-5400

Dear Mr. Ives and Mr. Whiteman:

Subject: Transmittal of Los Alamos Report, "Status and Implications of Seismic Hazard Studies at LANL"

Attached for your use is the report "Status and Implications of Seismic Hazard Studies at LANL," December 17, 1998, prepared by Larry Goen, ESA-EA, Los Alamos National Laboratory. The report summarizes the results of five recent seismic studies for various areas at Los Alamos National Laboratory, and makes note of two additional studies that are still in progress. It has been reviewed by staff at both DOE Headquarters and the DOE Albuquerque Operations Office. This final version incorporates comments made by Jeffrey Kimball, seismologist, DOE/HQ DP-45.

The stratigraphic survey for Technical Area (TA) 55 indicates that the area is not susceptible to surface rupture from earthquakes. The stratigraphic survey for TA-3 is in progress and a full report is not expected until March 1999. It appears that surface rupture from earthquakes is not a concern for those facilities at TA-3 that are not nuclear facilities. However, the discovery of a fault under the Chemistry and Metallurgy Research (CMR) Building, which is a nuclear facility, may have implications for decisions concerning the future use of CMR. The seismic studies also address ground motion from earthquakes, and indicate that this hazard is within the parameters assumed in the 1995 probabilistic seismic hazard analysis. The studies conclude that Laboratory structural standards remain valid in regards to ground motion.

Mr. Edwin E. Ives, DOE/HDQS
Mr. A. Earl Whiteman, DOE/AL
NW/M&M:98-20

-2-

December 22, 1998

I appreciate your interest in this subject. Your office has copies of the completed studies, and we will transmit the remaining studies as soon as they are completed.

Sincerely,



W. Scott Gibbs
Program Director
Materials and Manufacturing Programs

WSG:MDW:bjc

Att: a/s

Cy: John Ordaz, Program Manager, SWEIS, DOE/HQ DP-13
Corey Cruz, Project Manager, SWEIS, DOE/AL/EISPO
Jeffrey Kimball, DOE/HQ DP-45
Gary Palmer, DOE/HQ DP-45
James Daniel, DOE/HQ EH-42
Steven Ferguson, DOE/HQ, GC-51
Steven Dove, DOE/HQ, GC-30
Doris Garvey, LANL, ESH-EIS, M889
Larry Goen, LANL, ESA-EA, P946
CIC-10, A150
NW/M&M File

Status and Implications of Seismic Hazard Studies at LANL

Prepared By: Larry Goen, ESA-EA

Based on Work By: Jamie Gardner, EES-1
Don Krier, EES-1
Alexis Lavine, EES-1
Giday WoldeGabriel, EES-1
David Vaniman, EES-1
Doug Volkman, PM-2
Florie Caporuscio, Benchmark Environmental, Inc.
Susan Olig, Woodward Clyde Federal Services
Ivan Wong, Woodward Clyde Federal Services
Robert Youngs, Geomatrix Consultants, Inc.
James P. McCalpin, GEO-HAZ Consulting, Inc.

Los Alamos

NATIONAL LABORATORY

Los Alamos, New Mexico 87545

December 17, 1998

Status & Implications of Seismic Hazard Studies at LANL

CONTENTS

1.0 Summary	1
2.0 Introduction	3
3.0 Findings to Date	5
3.1 Surface Rupture Investigations	5
3.1.1 Fault Mapping and Surface Rupture Investigation at TA-55	5
3.1.2 Fault Mapping and Surface Rupture Investigation at TA-3	5
3.1.3 Probabilistic Surface Rupture Analysis	9
3.2 Paleoseismic Investigations	12
3.2.1 FY97 Paleoseismic Investigation on the Pajarito Fault	12
3.2.2 FY98 Paleoseismic Investigation on the Pajarito Fault	13
4.0 DOE Requirements	14
5.0 Implications of Findings	16
5.1 Surface Rupture at TA-3	16
5.2 Design Ground Motion	18
6.0 References	20

Status & Implications of Seismic Hazard Studies at LANL

TABLES

1. Seismic Hazard Studies	1
2. Probabilistic Surface Rupture Results	9
3. Performance Goals and Categories for SSCs	14
4. Peak Ground Accelerations at LANL	14
5. Net Slip Rates for Pajarito Fault Used In PSHA	19

FIGURES

1. Major Surface Faults at LANL	3
2. Map of Faulting in TA-55 Area	5
3. In Progress Map of Fault Locations in TA-3	7
4. Plan View of CMR Building With Inferred Location of Fault	8
5. Surface Rupture Hazard Curves for the SCC/NISC Site	10
6. Surface Rupture Hazard Curves for the CMR Site	11
7. Surface Rupture Hazard Curve Sensitivity Results	12
8. Locations of Paleoseismic Studies	13
9. Frequency of BIO Seismic Accidents and Fault Rupture	18

Status & Implications of Seismic Hazard Studies at LANL

1.0 Summary

A number of studies (Table 1) have been initiated in the last two years to address seismic issues at LANL. These studies have focused on the potential for surface rupture at TA-55 and TA-3 and the seismic hazard in general. For surface rupture, studies have centered around the mapping of faults in and around specific technical areas. In addition, a probabilistic surface rupture assessment has been completed for TA-3. For the seismic hazard, studies have focused on the earthquake history on the Pajarito fault.

Table 1 – Seismic Hazard Studies

Task	Status	Ref.
1) Stratigraphic Survey for TA-55	Complete	1
2) FY97 Pajarito Trench Study	Complete	3
3) Probabilistic Surface Rupture Assessment for TA-3	Complete	6
4a) Core Hole Study at SCC/NISC Site	Complete	5
4b) Core Hole Study at CMR Site	Complete	4
5) Stratigraphic Survey for TA-3	In Progress	N/A
6) FY98 Pajarito Trench Study	In Progress	N/A

Surface Rupture

The stratigraphic survey (Ref. 1) for TA-55 is complete and found no evidence for existing faults. Thus the area is not susceptible to surface rupture from earthquakes.

The stratigraphic survey for TA-3 is in progress and a full report is not expected until the end of March 1999. However, it is evident that TA-3 does have faults with vertical displacements in the range of 1-10 feet in 1.2 million year old Bandelier tuff. The heaviest concentration of these faults is in the southeast corner of TA-3. This concentration is believed to be defining the southern end of the Rendija Canyon fault. The faults found include one under the CMR Building (Ref. 4) with a vertical offset of approximately 8 feet.

While surface rupture can cause significant structural damage, surface rupturing earthquakes are low probability events. From the probabilistic assessment of surface rupture (Ref. 6), earthquakes that might result in permanent ground displacements of about four inches are estimated to be 10,000 to 20,000 year events. Four inches was taken as the threshold for a displacement causing severe cracking in a concrete or masonry structure. Earthquakes with would result in permanent ground displacements capable of causing structures to collapse are estimated to be 33,000 to 100,000 year events. The displacement threshold for collapse was taken as about 20 inches.

Based on the probabilistic study (Ref. 6), for non-nuclear structures, surface rupture is not a concern. The performance goal (annual probability of seismic induced damage) for such facilities

Status & Implications of Seismic Hazard Studies at LANL

per DOE guidance is 5×10^{-4} (2000 year recurrence interval). Designing to resist the ground motion caused by an earthquake is the primary concern when considering the seismic hazard. While surface rupture not a concern for non-nuclear structures, siting new facilities over known faults should not be done.

For the CMR Building, a nuclear facility, the probability of damaging ground displacement is at or beyond the performance goal for the facility, 1×10^{-4} (10,000 year recurrence interval). In its current condition, the probability of damaging ground motion is at least 20 times greater than the probability of damage caused by surface rupture. Therefore, the discovery of the fault under the building does not increase the seismic risk at CMR.

The discovery of a fault under the CMR Building has an impact on decisions concerning upgrades and future uses for the facility. From the seismic perspective, the question which needs to be assessed is whether or not it is prudent to upgrade the structure to resist ground motion loads when the probability of damaging surface rupture is near the performance goal level for the facility. While it is possible to upgrade to resist the forces/displacements caused by permanent ground deformation, the upgrade costs would increase substantially. It should be noted that this site would not be considered adequate for a new nuclear facility.

Ground Motion

In the last two years, a number of trenches have been excavated to study the earthquake history on the Pajarito fault. The purpose of the studies has been to determine when the most recent ground rupturing event occurred on the fault, to get a better understanding of recurrence intervals for earthquakes (slip rate), and to help determine if the three main faults in the Los Alamos area are connected.

For the seven trenches excavated in June 1998, data analysis is in progress and preliminary results are not available. For the seven trenches excavated in July 1997, the results (Ref. 3) show that the most recent event occurred 1500-2000 years ago with no other events in the last 10,000 years. The slip rates determined from this study indicate that they are within the parameters assumed in a 1995 probabilistic seismic hazard analysis. The 1995 study is the basis for the LANL design basis ground motion.

The significance of this information is that there is no direct evidence that the three local faults (Pajarito, Rendija Canyon and Guaje Mountain faults) are connected and the assumptions made in the probabilistic seismic hazard assessment completed in 1995 are still valid. Therefore, the design basis ground motion defined in the LANL structural standards is still valid.

Status & Implications of Seismic Hazard Studies at LANL

2.0 Introduction

In FY 1997, the first two tasks shown in Table 1 were undertaken to better understand the seismic hazard at the Los Alamos National Laboratory (LANL) site. One study was to investigate the possibility of the Rendija Canyon fault extending through Technical Area 55 (TA-55). The other was to investigate seismic history on the Pajarito fault, the main contributor to the seismic hazard for return periods of greater than 1,000 years. From preliminary results of these two studies, questions were raised concerning the possible connection of the Pajarito, Rendija Canyon and Guaje Mountain faults, shown in Figure 1, and surface rupture at TA-3. Both of the studies were finalized in FY98.

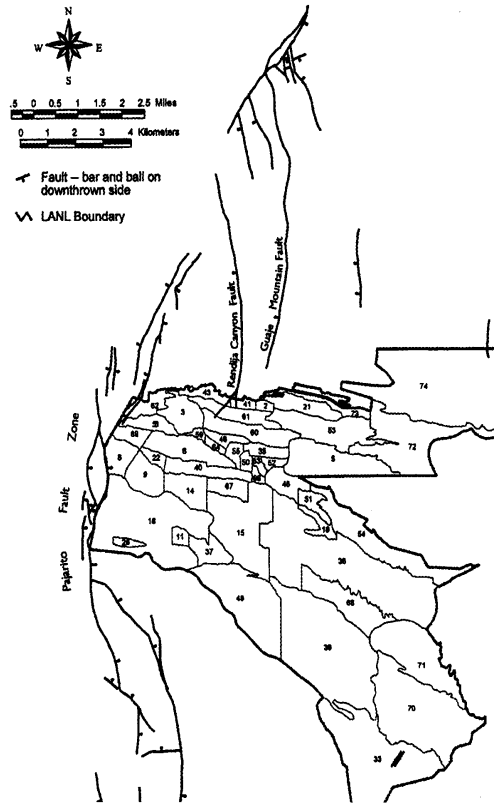

Figure 1 – Major Surface Faults at LANL

At TA-55, the study (Ref. 1) found that the Rendija Canyon fault does not project through TA-55 and that the site is free of any observable faulting. The study did find evidence for faulting further

Status & Implications of Seismic Hazard Studies at LANL

to the west, in the vicinity of TA-3. Data collection for the mapping of the faulting in the TA-3 area, the sixth task shown in Table 1, began in October, 1997 and continued through September 1998. Although the data have only been partially analyzed, it is evident that faulting is present in TA-3.

On the Pajarito fault, trench studies were conducted to try to estimate the last event on the fault, to try to estimate recurrence intervals on events, and to estimate slip rates. All of these factors were assumed in the seismic hazard evaluation (Ref. 2) completed in 1995 and physical data is needed to confirm that the assumptions made were conservative. The investigation (Ref. 3) initiated in FY97 has resulted in finding the most recent event on the Pajarito approximately 1500 - 2000 years ago and that slip rates were consistent with those assumed in Reference 2. In addition, a similar study, the sixth task in Table 1, began in FY98. For the FY98 study, the fieldwork is complete and data analysis is in progress.

In this report, the results of these studies plus those either completed or in progress are discussed as well as what the implications are for new and existing construction in TA-3. Findings for individual studies are first presented followed by a summary of DOE seismic requirements. Finally, the impacts on the understanding of the seismic hazard on facilities at LANL, in particular those in TA-3 such as CMR are presented.

Status & Implications of Seismic Hazard Studies at LANL

3.0 Findings to Date

The emphasis for work over the last two fiscal years falls in two categories: the potential for surface rupture at TA-55 and TA-3, and, investigation of the seismic history on the Pajarito fault.

3.1 Surface Rupture Investigations

Work in this area can be divided into three areas, fault mapping at TA-55 (1st task in Table 1), fault mapping at TA-3 (4th and 5th tasks in Table 1), and probabilistic surface rupture assessment of TA-3 (3rd task in Table 1).

3.1.1 Fault Mapping and Surface Rupture Investigation at TA-55

In Reference 1, results are presented of high-precision geologic mapping in the vicinity of TA-55 that has been done to identify parts of the southern portion of the Rendija Canyon fault, or any other faults, with the potential for seismic surface rupture. To assess the potential for surface rupture at TA-55, an area of approximately 3 square miles that includes the Los Alamos County Landfill and Twomile, Mortandad, and Sandia Canyons has been mapped in detail.

This mapping indicates that there is no faulting in the near surface directly below TA-55, and that the closest fault is about 1500 feet west of the Plutonium Facility. Faulting is more abundant on the western edge of the map area, west of TA-48, near TA-3, in uppermost Mortandad Canyon, upper Sandia Canyon, and at the County Landfill. With the exception of the County Landfill, measured vertical offsets ranged from 1 to 8 feet. At the County Landfill, faulting exposed has a distributed zone of faulting over 1000 feet wide with a net down to the west vertical displacement of 15 feet. Individual faults within this zone have vertical offsets ranging from 1 to greater than 15 feet. The area mapped is shown in Figure 2 (Ref. 1).

3.1.2 Fault Mapping and Surface Rupture Investigation at TA-3

The surface rupture investigation at TA-3 includes locating and mapping of existing faults using two different methods. One of methods used is high precision location of stratigraphic contacts using total station surveying techniques in the canyons to the north and south of TA-3. The other method is the drilling of core holes to locate stratigraphic contacts at specific sites, namely the CMR site (Ref. 4) and the proposed site for the Strategic Computing Center (SCC) and Nonproliferation and International Security Center (NISC) projects (Ref. 5), within TA-3.

High Precision Mapping at TA-3:

High precision mapping at TA-3, similar to that accomplished in the TA-55 area, is an in-progress study. Data collection for this study was completed in September, 1998. Data analysis and report writing is ongoing. The final report is expected to be completed in March, 1999.

Status & Implications of Seismic Hazard Studies at LANL

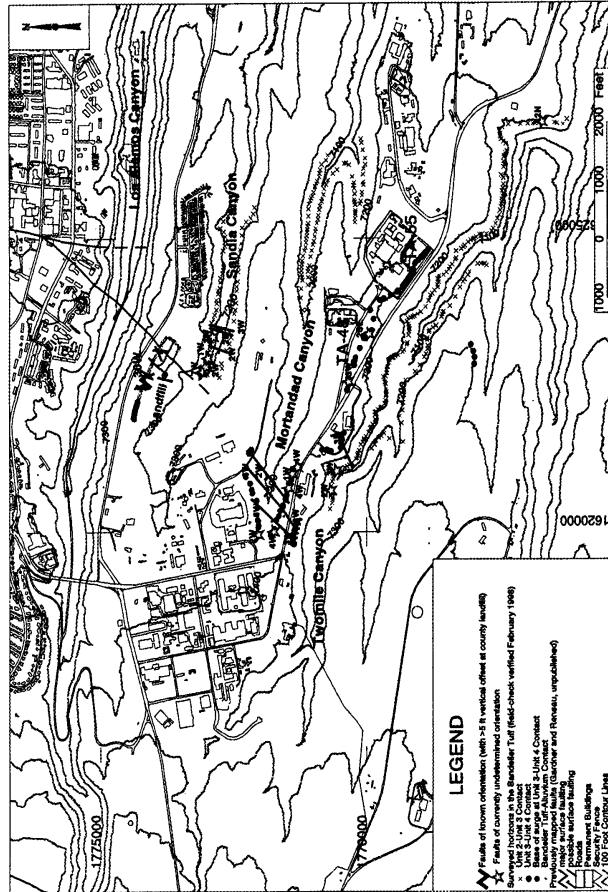

Figure 2 – Map of Faulting in TA-55 Area (Ref. 1)
Numbers and letters adjacent to faults indicate the amount of displacement (in feet) and sense of displacement (e.g., 4W = 4 feet of displacement down to the west).

The areas surveyed in the data collection portion of this study are indicated in Figure 3. Along with the survey locations, Figure 3 also depicts the location of linear features found in the examination of air photos dating to the 1940's. The linear features could indicate the location of faults, but could also indicate other linear features such as fences trails and roads. These linear features are being used as guides in the data analysis currently underway. As the data analysis progresses, it is expected that some of the air photo lineaments will be designated faults while others will be removed from the map.

Status & Implications of Seismic Hazard Studies at LANL

Although data analysis is in progress, preliminary findings indicate faulting is present in the TA-3 area. The majority of the faults is in the southeastern area of TA-3. These faults have vertical offsets in the range of 1 to 10 feet.

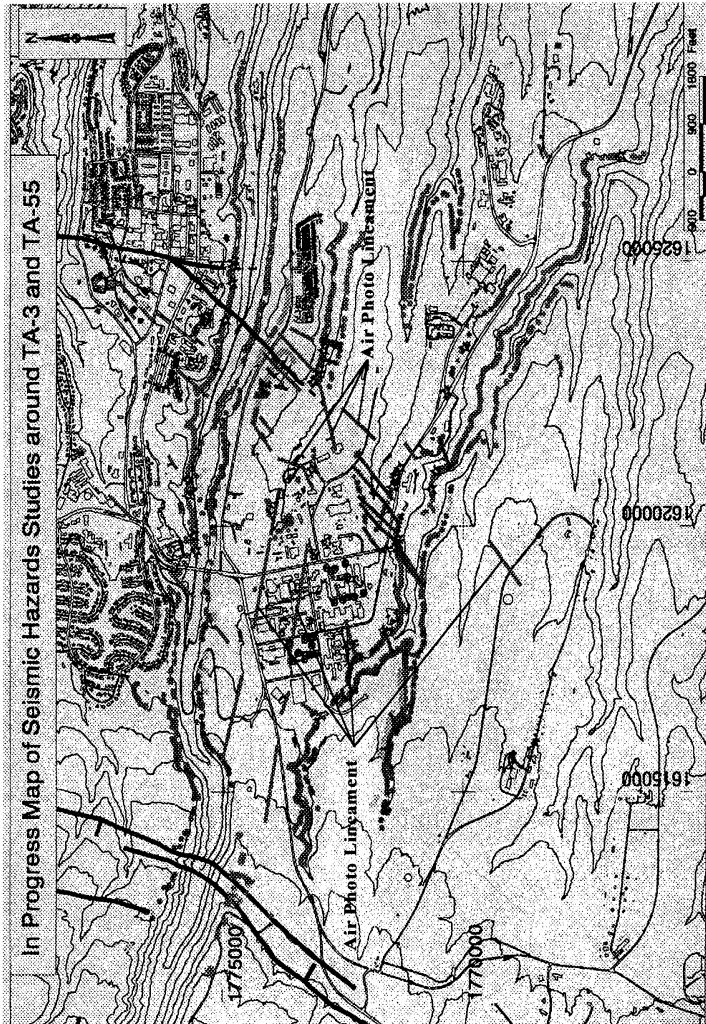

Figure 3 – In Progress Map of Fault Location in TA-3
 Unless indicated as “Air Photo Lineament” (purple lines), lines indicate faults of known orientation. Stars represent faults of unknown orientation. Dots indicate surveyed points of stratigraphic contacts.

Status & Implications of Seismic Hazard Studies at LANL

CMR Core Hole Investigation:

At the site of the existing Chemistry and Metallurgical Research (CMR) Building, nine closely spaced, shallow holes were drilled. The purpose of the holes was to obtain the cores and to establish the elevation at which contacts between particular layers of the Bandelier Tuff are located. These elevations were then used to develop a contour map at a particular contact. Abrupt changes in the contours would indicate the presence of faulting. The goal of the investigation was to identify faults that may have the potential for earthquake-induced surface ruptures at the site.

Analysis (Ref. 4) of the data obtained indicates that a fault is present at the CMR Building. Its location and inferred orientation are shown in Figure 4. The fault is contained within the core obtained from the CMR-6 and can be inferred to occur between the CMR-2 and CMR-3 locations. This orientation is consistent with one of the air photo lineaments shown in Figure 3. The total displacement of Unit 3 in the CMR-6 core is approximately 8 feet.

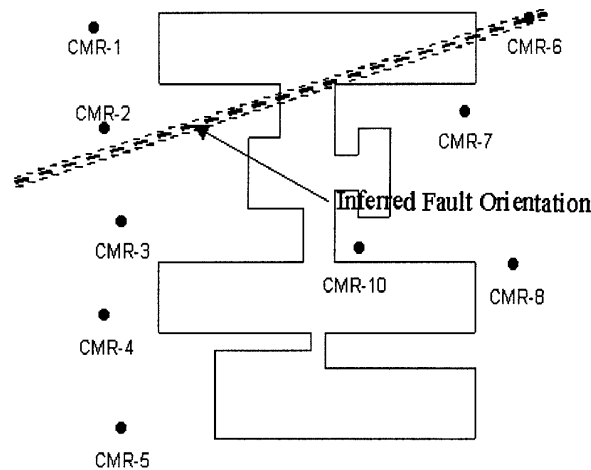

Figure 4 – Plan View of CMR Building With Inferred Location of Fault

Based on this investigation, it can be concluded that the CMR Building site has, in the past, been impacted by fault rupture. However, as discussed later in this report, the probability of an earthquake causing significant surface displacement at this site in the future is small.

SCC/NISC Core Hole Investigation:

At the site proposed for the new Strategic Computing Center (SCC) and the new Nonproliferation and International Security Center (NISC) projects, ten closely spaced, shallow holes were drilled. The purpose of the holes is the same as the holes drilled at the CMR Building.

Status & Implications of Seismic Hazard Studies at LANL

From analysis (Ref. 5) of the data gathered, there is no evidence for faults under the building sites. Because no significant or cumulative faulting events have disturbed the site in the last 1.22 million years, the age of the Bandelier Tuff, it is unlikely that surface rupture will occur at the site in future large earthquakes.

3.1.3 Probabilistic Surface Rupture Analysis

A probabilistic seismic hazard analysis for potential surface fault displacement at TA-3 has been performed and is described and summarized in Reference 6. The objective of the analysis was to estimate the potential surface rupture hazard posed by the Pajarito fault system, in particular, a possible splay of the Rendija Canyon fault that may transect TA-3. The principal products of this study are probabilistic surface rupture hazard curves for the CMR and SCC/NISC sites. The study focused on these two sites at TA-3 and provides bounding case assessments of the surface rupture potential at each site.

Three different cases were considered in the hazard analysis: (1) distributed faulting only; (2) principal faulting at the CMR site; and, (3) principal faulting at the SCC/NISC site. Principal faulting is faulting occurring along the main plane(s) of crustal weakness responsible for the release of seismic energy during an earthquake. Distributed faulting is defined as rupture that occurs on other faults, shears, or fractures in the vicinity of the principal rupture in response to the principal displacement. The three cases correspond to three different possible scenarios for the southern end of the Rendija Canyon fault. For Case 1, three different hypothetical conditions were assumed: (a) a distributed fault with 9m of cumulative displacement in the Bandelier Tuff, (b) a distributed fault with 1m of cumulative displacement, and (c) a fracture with no observable displacement in the tuff. A total of 15m of cumulative displacement is assumed in cases 2 and 3.

The results, summarized in Table 2, show that for annual frequencies of 10^{-4} or larger, surface rupture is minimal or nonexistent. The hazard curves developed for the two sites are shown in Figures 5 and 6. Hazard curves that investigate the sensitivity of the three main faults being connected or not are shown in Figure 7.

Table 2 – Probabilistic Surface Rupture Results

Annual Frequency	Case 1a	Case 1b	Case 1c	Case 2&3
10^{-4}	<1 mm	<1 mm	<1 mm	2 cm
10^{-5}	50 cm	20 cm	10 cm	70cm

Status & Implications of Seismic Hazard Studies at LANL

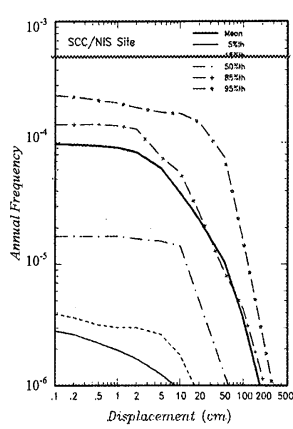

Figure 5a – Case 1a:
Distributed Faulting w/ 9m
Cumulative Displacement

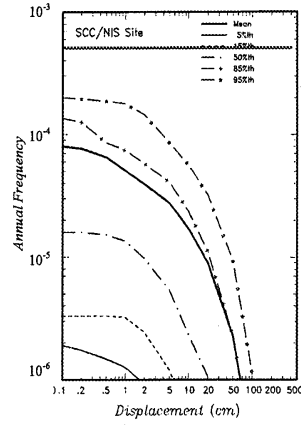

Figure 5b – Case 1b:
Distributed Faulting w/ 1m
Cumulative Displacement

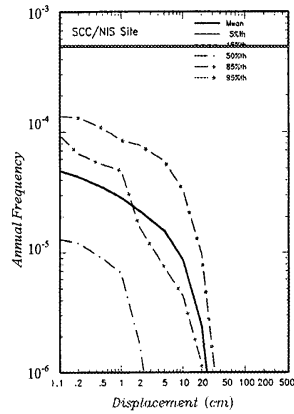

Figure 5c – Case 1c:
Distributed Faulting w/ no
Cumulative Displacement

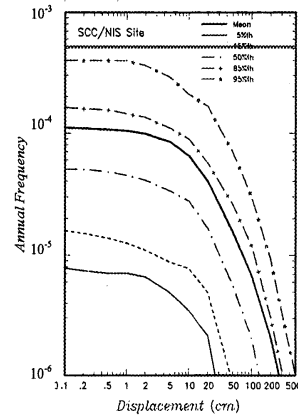

Figure 5d – Case 2:
Principal Faulting w/ 15m
Cumulative Displacement

Figure 5 – Surface Rupture Hazard Curves for the SCC/NIS Site (Performance Goal for PC 2 Facilities is 5×10^{-4})

Status & Implications of Seismic Hazard Studies at LANL

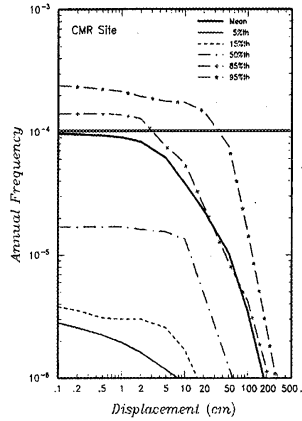

Figure 6a - Case 1a:
Distributed Faulting
9m Cum. Displacement

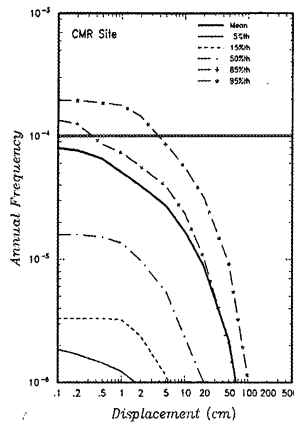

Figure 6b - Case 1b:
Distributed Faulting
1m Cum. Displacement

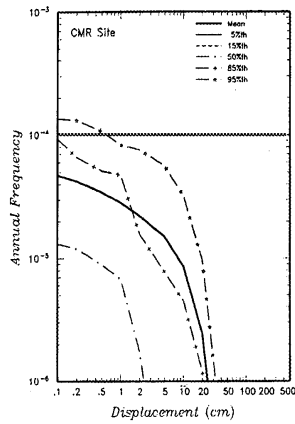

Figure 6c - Case 1c:
Distributed Faulting
No Observable Displacement

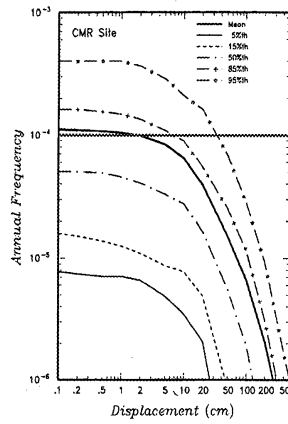

Figure 6d - Case 3:
Principal Faulting
15m Cum. Displacement

Figure 6 – Surface Rupture Hazard Curves for the CMR Building Site (Performance Goal for PC 3 Facilities is 1×10^{-4})

Status & Implications of Seismic Hazard Studies at LANL

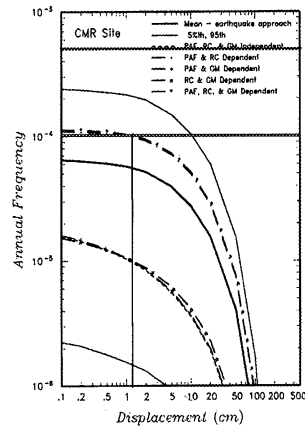

Figure 7a – Case 1b
Distributed Faulting w/ 1m
Cumulative Displacement

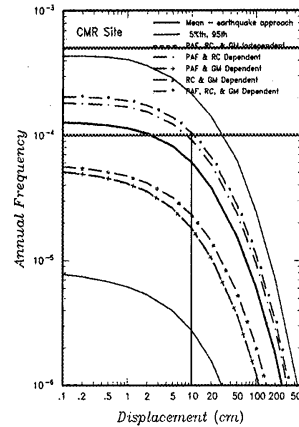

Figure 7b – Case 3:
Principal Faulting w/ 15m
Cumulative Displacement

Figure 7 – Surface Rupture Hazard Curve Sensitivity Results (Illustrates the effects of assuming fault dependency on hazard curves.)

3.2 Paleoseismic Investigations

Recent paleoseismic investigations have focussed on the Pajarito Fault. Two separate but related studies were initiated in Fiscal Year 1997 and Fiscal Year 1998. Locations of the studies are shown in Figure 8. Fieldwork for the paleoseismic studies is completed in a fairly short time frame but the analysis of samples required to develop date constraints is a time consuming process. Thus, work initiated in one fiscal year typically carries over to the following fiscal year to obtain dating information.

3.2.1 FY97 Paleoseismic Investigation on the Pajarito Fault

In July 1997, seven trenches were excavated across strands of the Pajarito fault zone to characterize the most recent faulting event (MRE), and to refine characterization of previous faulting events. The strategy for capturing the MRE was to excavate a series of seven trenches along an east-west transect across the fault zone south of Los Alamos Canyon, where parallel faults span a zone nearly 2 km wide. Two of the seven trenches were located on the main 50 m high scarp of the Pajarito fault, with the remainder on smaller east- and west-facing scarps. This study is presented in Reference 3.

Status & Implications of Seismic Hazard Studies at LANL

The best paleoseismic records were preserved on scarps that faced west, or upslope. Each of these trenches displayed evidence of mid- to late-Holocene MRE. The MRE appears to fall in a relatively narrow age range between about 1300 to 2300 years ago with a likely age of about 1500 years.

The MRE dated at about 1500 years does not appear to be contemporaneous with the MRE on the Guaje Mountain fault, dated at 4000-6000 years or the MRE on the Rendija Canyon fault, dated at either 8 or 23 thousand years. The trenches on the Pajarito do not show evidence for either a second (or third) earthquake at either 4000-6000 years or 8000 years. Thus, it appears that the MREs on each of the three faults in the Pajarito fault system are separate earthquakes.

3.2.2 FY98 Paleoseismic Investigation on the Pajarito Fault

In June, 1998, seven additional trenches were excavated across the Pajarito fault zone further south than the FY97 study. Again, the purpose of the excavations was to characterize the most recent faulting event (MRE), and to refine characterization of previous faulting events. While the fieldwork is complete, analysis of the data obtained is ongoing. The final report is to be complete in March, 1999.

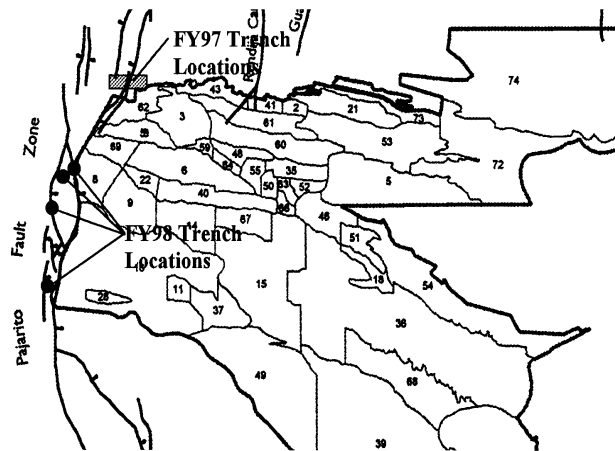

Figure 8 – Locations of Paleoseismic Studies

Status & Implications of Seismic Hazard Studies at LANL

4.0 DOE Requirements

The DOE, through orders and standards, provides guidance for facility siting and design with respect to earthquakes. The guidance is probabilistically based.

The Implementation Guide to DOE Order 420.1 "Natural Phenomena Hazards for DOE Nuclear Facilities and Non-Nuclear Facilities" (Ref. 7) requires that structures systems and components be designed and constructed to withstand the effects of natural phenomena hazards (NPH) using a graded approach. The target safety levels for structures systems and components (SSCs) subject to NPH are given in the guide in terms of performance goals. These performance goals are defined as the acceptable annual probability of failure. The performance goals are shown in Table 3 and are a function of performance categorization. Performance categorization is determined in accordance with DOE STD 1021 (Ref. 8). The guide also states that siting of structures over active geologic faults should be avoided.

Table 3 - Performance Goals and Categories for SSCs

Performance Category	Description of Performance Required	Seismic Performance Goal
PC0	No consideration.	N/A
PC1	Prevent major structural damage or collapse which would endanger personnel (life-safety).	1×10^{-3}
PC2	Maintain operation of essential facilities allowing relatively minor structural damage.	5×10^{-4}
PC3	Confinement of hazardous materials.	1×10^{-4}
PC4	Confinement of hazardous materials	1×10^{-5}

DOE STD 1020 (Ref. 9) specifies seismic loading in probabilistic terms. The annual exceedance probability for the ground motion associated with the various performance categories is shown in Table 4. The peak ground accelerations for LANL are based on the information in Reference 2.

**Table 4
Peak Ground Accelerations at LANL**

Performance Category	Annual Probability of Exceedance (Return Period)	Horizontal Peak Ground Acceleration (g)	Vertical Peak Ground Acceleration (g)
PC1	2×10^{-3} (500 yr.)	0.15	0.11
PC2	1×10^{-3} (1,000 yr.)	0.22	0.19
PC3	5×10^{-4} (2,000 yr)	0.31	0.27
PC4	1×10^{-4} (10,000 yr)	0.57	0.58

For seismic design, the standard recommends using deterministic design rules that are familiar to design engineers and which have a controlled level of conservatism. This level of conservatism combined with the specification of probabilistic seismic loading leads to performance goal achievement.

Status & Implications of Seismic Hazard Studies at LANL

DOE STD 1022 (Ref. 10) provides guidance for NPH Characterization Criteria including the necessity for establishing the potential for surface rupture and points to EPA guidance for offsetting hazardous waste facilities from active faults. Active faults are characterized “by the presence of surface or near surface deformation of geologic deposits of a recurring nature within the last approximately 500,000 years or at least one in the last approximately 50,000 years.”

DOE STD 1023 (Ref. 11) provides criteria for NPH assessment. In this document, some guidance is provided for ground failure (surface rupture). If surface rupture may occur near a facility, a probabilistic evaluation may be necessary. If the annual probability of ground failure is greater than the necessary performance goal either the site should be avoided, mitigation measures taken, or an evaluation performed of the effects of fault offset.

Status & Implications of Seismic Hazard Studies at LANL

5.0 Implications of Findings

This section discusses the implication of the findings on projects at TA-3 and for the Laboratory in general. These studies have implications for LANL in two areas: (1) surface rupture potential at TA-3 with respect to both non-nuclear facilities and the CMR Building, and (2) design ground motion for all facilities.

5.1 Surface Rupture at TA-3

The studies to date indicate that there are faults in some locations at TA-3 including under the CMR Building. These faults will be addressed in a manner consistent with DOE guidance. For new facilities, building sites will be selected such that "active" faults are avoided. For existing facilities that are located over faults, assume they meet "active" criteria and a probabilistic approach will be followed.

Non-Nuclear Facilities (PC 1 and PC 2):

For the SCC and NISC projects, a site specific study (Ref. 5) was performed to determine if faulting was present at the proposed site. The results of this study indicate the site is clear of faulting and is therefore acceptable for new construction.

For existing facilities, hazard curves developed in the probabilistic surface rupture study (Ref. 6) for TA-3 are used. At the performance goals for PC 1 and PC 2, 1×10^{-3} and 5×10^{-4} , respectively, the estimated displacement for any of the cases as shown in Figures 4 and 5 and summarized in Table 2 is less than 1 millimeter. This is true even for the case where all faults are assumed to be connected. This small amount of displacement has a negligible effect on structures. Therefore, for existing PC 1 and PC 2 facilities, surface rupture is not a credible hazard and the only aspect of the seismic hazard at TA-3 that should be considered is ground motion.

The CMR Building (PC 3)

As previously indicated, it has been determined that there is an existing fault under the CMR. The vertical offset in this fault is approximately 8 feet. The identification, location and orientation of the fault under the CMR shown in Figure 4 is based on air photo interpretation, high precision mapping of faults in canyons to the south of TA-3, and examination of cores taken from the nine holes drilled around the CMR Building. The air photos indicate a linear feature running through the CMR site from the northeast corner of the facility and through the site to the west-southwest. The high precision mapping effort located a fault with about 5 feet of vertical offset in Twomile Canyon to the southwest which coincides with the southwest end of the air photo feature running through the CMR site. The examination of the cores showed that the core taken at the northeast corner (CMR-6) of the facility cut through a fault with a total vertical offset of about 8 feet and that it is likely that the same fault lies between cores CMR-2 and CMR-3. This information also coincides with the air photo feature. The location and orientation of the fault shown in Figure 4 are consistent with the information known to date.

Status & Implications of Seismic Hazard Studies at LANL

If this site were to be considered for a new nuclear facility, it would not be used and an alternate site, clear of faulting concerns, would be chosen. However, since this is an existing facility, the impact on the safe operation of the facility must be assessed. For this assessment a probabilistic approach is used.

The CMR Building is a PC 3 facility that contains special nuclear materials. The performance goal for design basis earthquakes is 1×10^{-4} . The vertical offset of the fault under the facility lies between the existing conditions evaluated in cases 1a (9m offset) and 1b (1m offset) in Reference 6. As shown in Table 2, the probable offset for these cases at the performance goal is less than 1 mm. This small amount of displacement has a negligible effect on structures and it could be concluded that the discovery of this fault is not a credible hazard for the design basis event.

However, if the worse case assumption is made that this is a principal fault and that all three faults are connected, the estimated offset from Figure 6 for the PC 3 performance goal is approximately 10 centimeters (4 inches). A displacement of this magnitude can cause significant cracking in a concrete shear wall structure such as those used in the construction of the CMR Building. This cracking could result in a loss of confinement.

It can be shown (Ref. 12) that the annual probability of seismic induced failure, based on ground motion associated with an earthquake, is about 2×10^{-3} for most areas of the CMR Building. The exceptions to this is the vault that has an annual probability of seismic induced failure, again, based on ground motion, of about 7×10^{-5} , and the floor wells which have yet a lower probability of failure. The significance of this information is that ground motion could cause a loss of confinement for most areas of the CMR Building at frequency that is at least 20 times greater than surface rupture.

In the safety analysis for the CMR Building, the consequences of the seismic accident are assessed assuming that the CMR building, with the exception of the vault and floor wells, collapses at the frequency indicated above. With the vault and floor wells located such that they would not be directly effected by a surface displacement, the assumptions used in the safety analysis for the seismic accident are still valid even with new knowledge of a fault beneath the facility.

Based on current available information, the fault under the CMR site is a subsidiary fault. As a result, any movement on the fault is likely to be small and would be a result of a large (Magnitude 6 to 7) earthquake on the Rendija Canyon or the Pajarito fault. Such earthquakes are low probability events. In Figure 9 the estimated annual frequency of damage caused by ground motion is compared to the annual frequency of damage caused by surface rupture. This figure illustrates that damaging surface rupture is far less likely to occur than damaging ground motion.

Status & Implications of Seismic Hazard Studies at LANL

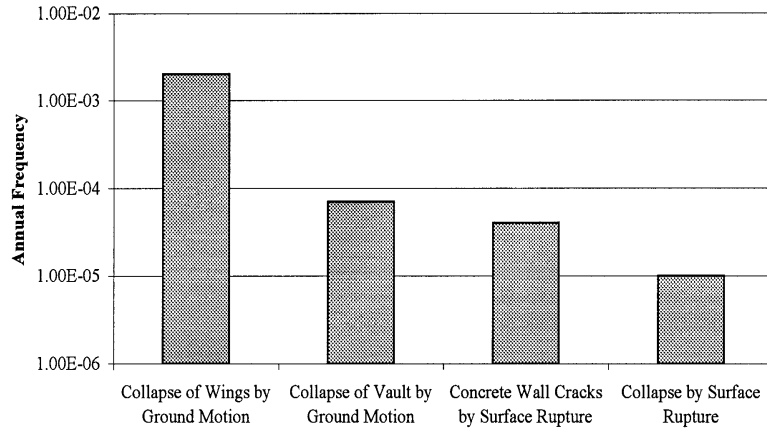

Figure 9 – Frequency of Seismic Induced Damage at CMR Building

5.2 Design Ground Motion

Of the current seismic hazard studies, only the paleoseismic investigations could influence the design ground motion at LANL. At this time only the information from the FY97 study can be assessed for its impact.

The design ground motion at LANL is based on the results of the probabilistic seismic hazard analysis (PSHA) presented in Reference 2. According to this reference, the net slip rate of the Pajarito fault is the most important input parameter in the PSHA. For this fault the PSHA assumed the slip rates shown in Table 5. One of the objectives of the paleoseismic investigations is to get a more accurate assessment of the slip rate on the Pajarito fault.

Table 5 – Net Slip Rates for Pajarito Fault Used In PSHA

Net Slip Rate (mm/yr)	Probability ¹	Percentile ²
0.01	0.1	5 th
0.05	0.2	20 th
0.09	0.4	50 th
0.20	0.2	80 th
0.95	0.1	95 th

¹Probability used in PSHA Logic Tree

²Cumulative percentile

Based on the results of the FY97 paleoseismic investigation (Ref. 3) on the Pajarito fault, the net slip rate is 0.06-0.21 mm/yr. The lower of the two values is less than the median slip rate value of 0.09 mm/yr assumed in the PSHA. The higher of the two values is approximately equal to 80th

Status & Implications of Seismic Hazard Studies at LANL

percentile motion assumed in PSHA. Therefore, the slip rates calculated in the 1997 study are already covered in the PSHA documented in Reference 2.

Questions concerning the dependency of the three major faults are based on the physical location and style of deformation of the three faults. Their relative proximity to one another and style of deformation could lead to the conclusion that they must be connected at depth below the earth's surface. However, based on the paleoseismic studies to date, there is no evidence that supports this conclusion. The MRE on the Pajarito fault, dated at 1500-2000 years, is not coincident with either the MRE on the Guaje Mountain fault, dated at 4000-6000 years or the MRE on the Rendija Canyon fault, dated at either 8 or 23 thousand years. The trenches on the Pajarito do not show evidence for either a second (or third) earthquake at either 4000-6000 years or 8000 years.

Status & Implications of Seismic Hazard Studies at LANL

References

1. Gardner, Lavine, Vaniman, WoldeGabriel, "High-Precision Geologic Mapping to Evaluate the Potential for Seismic Surface Rupture at TA-55, Los Alamos National Laboratory", LA-13456-MS, Los Alamos National Laboratory, Los Alamos, New Mexico, June, 1998
2. Wong, Kelson, Olig, Kolbe, Hemphill-Haley, Bott, Green, Kanakari, Sawyer, Silva, Stark, Haraden, Fenton, Unruh, Gardner, Reneau and House, "Seismic Hazard Evaluation of the Los Alamos National Laboratory", Woodward Clyde Federal Services, Oakland, California, February, 1995
3. McCalpin, "Late Quaternary Faulting on the Pajarito Fault, West of Los Alamos National Laboratory, North-Central New Mexico: Results from the Seven-Trench Transect Excavated in Summer of 1997", GEO-HAZ Consulting, Inc., Estes Park Colorado, August, 1998.
4. Krier, Caporuscio, Gardner and Lavine, "Stratigraphy and Geologic Structure at the Chemistry and Metallurgical Research (CMR) Building, Technical Area 3, Los Alamos National Laboratory, New Mexico", LA-13522-MS, Los Alamos National Laboratory, Los Alamos, New Mexico, October, 1998
5. Krier, Caporuscio, Lavine and Gardner. "Stratigraphy and Geologic Structure at the SCC and NISC Building Sites, Technical Area 3, Los Alamos National Laboratory, New Mexico", LA-13507-MS, Los Alamos National Laboratory, Los Alamos, New Mexico, September, 1998
6. Olig, Youngs and Wong, "Probabilistic Seismic Hazard Analysis for Surface Fault Displacement at TA-3 Los Alamos National Laboratory", Woodward Clyde Federal Services, Oakland, California, July, 1998
7. U.S. Department of Energy, "DOE G 420.1, Interim Guidelines for the Mitigation of Natural Phenomena Hazards for DOE Nuclear and Non-Nuclear Facilities", *DRAFT*, November, 1995
8. U.S. Department of Energy, "Natural Phenomena Hazards Performance Categorization Guidelines for Structures, Systems and Components", DOE STD 1021-93, January, 1996
9. U.S. Department of Energy, "Natural Phenomena Hazards Design and Evaluation Criteria for Department of Energy Facilities", DOE STD 1020-94, January, 1996
10. U.S. Department of Energy, "Natural Phenomena Hazards Characterization Criteria", DOE STD 1022-94, January, 1996
11. U.S. Department of Energy, "Natural Phenomena Hazards Assessment Criteria", DOE STD 1023-95, January, 1996
12. Goen, Los Alamos National Laboratory Memorandum from Larry Goen to Chris Steele, "Summary Report – Seismic/Structural Review of the CMR Building In Support of the BIO/TSR Project", ESA-EA:97-290, December 9, 1997