

B O N N E V I L L E
P O W E R A D M I N I S T R A T I O N



Level I Accident Investigation Report

Wilson Construction Company Employee Fatality on the Bandon-Rogue No. 1 115kV Line

July 30, 2013

**Report Date:
September 2013**

DISCLAIMER

This report is an independent product of the Level I Accident Investigation Board appointed by Brad Bea, Chief Safety Officer, Bonneville Power Administration. The Board was appointed to perform a Level I Accident Investigation and to prepare an investigation report in accordance with *Bonneville Power Administration Manual*, Chapter 181, *Accident Investigation and Reporting*.

The discussion of the facts as determined by the Board and the views expressed in the report do not assume, and are not intended to establish, the existence of any duty at law on the part of the U.S. Government, its employees or agents, contractors, their employees or agents, or subcontractors at any tier, or any other party.

This report neither determines nor implies liability.

RELEASE AUTHORIZATION

On August 7, 2013, an Accident Investigation Board was appointed to investigate the fatality of a Wilson Construction Company Crew Foreman on the Bandon-Rogue No. 1 115kV line. The Board's responsibilities have been completed with respect to this investigation. The analysis and the identification of the causal factors and the Findings and Recommendations resulting from this investigation were performed in accordance with *Bonneville Power Administration Manual*, Chapter 181, *Accident Investigation and Reporting*.

The report of the Accident Investigation Board has been accepted and the authorization to release this report for general distribution has been granted.



Brad Bea
Chief Safety Officer, Bonneville Power Administration



Date

TABLE OF CONTENTS

SCOPE OF INVESTIGATION	
EXECUTIVE SUMMARY	ES-1
1. INTRODUCTION	1
1.1. About Bonneville Power Administration	1
1.2. Transmission Engineering Services.....	1
1.3. Wilson Construction Company.....	1
1.4. Jacobs Engineering Group Inc.....	2
1.5. Aerotek.....	2
2. FACTS AND ANALYSIS	3
1.1. Description of Work Activity	3
2.1. Description of the Accident	5
2.2. Chronology of Events	10
2.3. Emergency Response and Investigative Readiness	11
2.4. Medical Analysis/Fitness for Duty	14
3. WORK PROCESSES AND CONTROLS	15
3.1. General Contractor Project Communication Process	15
3.2. Wilson Construction Company Safety Management Processes	16
3.3. Jacobs Safety Management Responsibilities	23
3.4. Crew Foreman 2 Training.....	24
4. ANALYSIS	26
4.1. Barrier Analysis	26
4.2. Change Analysis	26
4.3. Post-Accident Powerline Modeling of Induced Voltages.....	27
4.4. Events and Causal Factors Analysis	30
5. EXAMINATION OF EVIDENCE	32
5.1. Findings and Recommendations.....	32
6. BOARD OF AUTHORITY LETTER	37
6.1. Update to Board of Authority Letter.....	39
7. BOARD MEMBERS' SIGNATURES	41
Appendix A. Barrier Analysis	Appendix A-1
Appendix B. Change Analysis	Appendix B-1
Appendix C. Accident Chronology	Appendix C-1
Appendix D. Events and Causal Factor Chart	Appendix D-1
Appendix E. Glossary	Appendix E-1
Appendix F. Accident Investigation Terminology	Appendix F-1

FIGURES AND TABLES

Figure 1: Geisel Monument Worksite.....	4
Figure 2: Riser and Jumper Location on Structure 46/5	5
Figure 3: Aerial View of the 46/5 and 46/6 Structures at the Geisel Monument Tap	6
Figure 4: Grounds Installed by Crew 2 at Worksite 46/5	8
Figure 5: Structure 46/5S Switch B447	9
Figure 6: General Contractor Project Communication Diagram	15
Figure 7: The Human Body Resistance Model.....	28
Table ES-1: Findings and Recommendations	ES-2
Table 1: Chronology of the Accident.....	10
Table 2: Chronology of Rescue Activities.....	12
Table 3: Findings and Recommendations.....	32
Table A-1: Barrier Analysis	Appendix A-1
Table B-1: Change Analysis Worksheet	Appendix B-1
Table C-1: Accident Chronology.....	Appendix C-1
Table D-1: Events and Causal Factors Chart	Appendix D-2
Table F-1: Accident Investigation Terminology	Appendix F-1

Legend

Crew 1 working at 46/6

CF1	Wilson Crew Foreman 1
JL1	Wilson Journeyman Lineman 1
EO1	Wilson Equipment Operator 1

Crew 2 working at 46/5

CF2	Wilson Crew Foreman 2
JL2	Wilson Journeyman Lineman 2
EO2	Wilson Equipment Operator 2

SI	Wilson Site Superintendent
QA/QC	Wilson Quality Assurance/Quality Control/Safety Audit Manager

CM	Aerotek Construction Manager
CO1	BPA Contracting Officer for Wilson contract
CO2	BPA Contracting Officer for Wilson contract
CO3	BPA Contracting Officer for Jacobs contract
COTR	BPA Contracting Officer's Technical Representative

RE	Jacobs Resident Engineer
QAR 1	Jacobs Quality Assurance Representative 1
QAR 2	Jacobs Quality Assurance Representative 2

Acronyms

AED	Automated External Defibrillator
BPA	Bonneville Power Administration
CAIS	Contract Administration Information System
CPR	Cardiopulmonary Resuscitation
DOE	Department of Energy
EMS	Emergency Medical Services
EMT	Emergency Medical Technicians
EPZ	Equipotential Zone
MCC	Munro Control Center
PMA	Power Marketing Administrations
PPE	Personal Protective Equipment
QA	Quality Assurance
RFI	Request for Information
THA	Task Hazard Analysis
WCC	Wilson Construction Company

SCOPE OF INVESTIGATION

On August 7, 2013, at the request of the Bonneville Power Administration (BPA) Chief Safety Officer, a Level I Accident Investigation was convened to investigate an accident that resulted in the fatality of a Wilson Construction Company Crew Foreman.

The purpose of the investigation was to determine the cause of the accident and to develop recommendations for corrective actions to prevent recurrence.

The scope of the investigation included gathering and documenting all relevant facts of the accident, conducting interviews, review of employee statements, work procedures, management systems, and other elements factoring into the incident. The scope also included the Bonneville Power Administration's programs and oversight activities.



EXECUTIVE SUMMARY

Introduction

On the morning of July 30, 2013, a Wilson Construction Company (WCC) Crew Foreman (CF2) was fatally injured while preparing to remove a jumper from a sectionalizing disconnect switch on the Bandon-Rogue No. 1 115kV line.

On August 7, 2013, the Chief Safety Officer for Bonneville Power Administration (BPA) appointed a Level 1 Accident Investigation Board (the Board) to investigate the accident, in accordance with the requirements of *Bonneville Power Administration Manual*, Chapter 181, *Accident Investigation and Reporting*.

Accident Description

On July 30, 2013, at approximately 0700, the WCC work crews assembled at their materials yard located near U.S. Route 101 on Cape Blanco Road in Curry County, Oregon. A general safety meeting was conducted with personnel from Wilson, Jacobs and Aerotek in attendance. Grounding for the Geisel Monument (Geisel) worksite was discussed.

After gathering tools, materials and trucks, the crews traveled to the Geisel worksite and conducted a job briefing including a Task Hazard Analysis (THA). The plan of the day was to relocate two 115kV sectionalizing disconnect switches at Geisel.

By about 0930, WCC Crew Foreman 2 (CF2) climbed up to the top of B447 switch stand to attach lift slings suspended from the crane. Once the lift slings were placed and pulled up snug, CF2 positioned himself to assist in the removal of the blade end sectionalizing jumper on B-phase.

At approximately 0945, CF2 made contact with a difference of potential across the blade end insulator stack of B447.

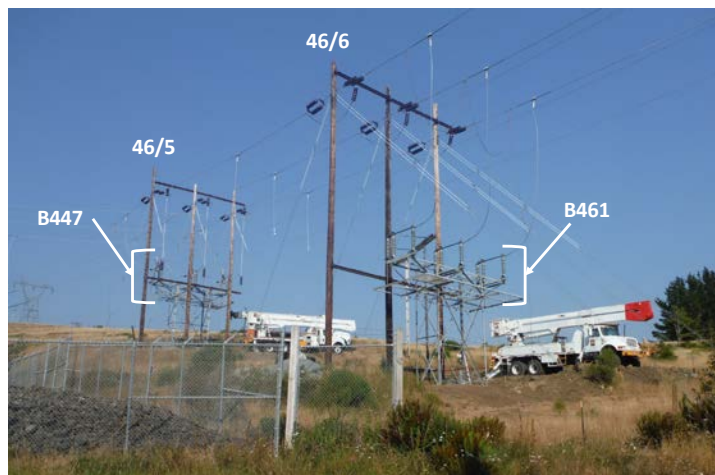

Accident Response

The on-site crew heard CF2 yell, and Equipment Operator 2 (EO2) saw an arc and noticed that CF2 had fallen back into his work positioning belt and harness. While 911 was called, other crew members began to initiate rescue operations.

Using a bucket truck, CF2 was lowered to the ground, and positioned for cardiopulmonary resuscitation (CPR). CPR was performed until the EMS personnel arrived on the scene. The

EMS' automated external defibrillator (AED) was used. CF2 was transported by ambulance at 1010 and pronounced dead at 1051 at Curry General Hospital in Gold Beach, Oregon.

Results of the Investigation (Findings and Recommendations)

The Board determined the facts of the accident and analyzed the facts to determine what happened, why it happened, and what needs to be done to prevent recurrence. The Board used Barrier Analysis, Change Analysis and Causal Factors Analysis to arrive at Findings and Recommendations, which if implemented should prevent a similar accident.

The Board concluded the **direct cause** of the accident was that CF2 made contact with a difference of potential across the blade end insulator stack of B447.

The Board concluded the **root cause** of the accident was Crew 2's failure to establish an equipotential zone (EPZ).

The Board identified 11 **contributing causes** to the accident. The complete list of contributing causes can be found in Section 4.4: Events and Causal Factors Analysis.

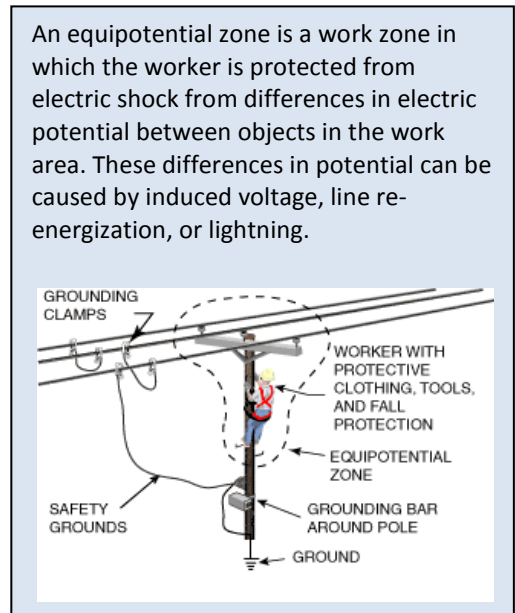

Table ES-1: Findings and Recommendations

Findings	Recommendations
Emergency Response	
<p>F1: The Board found that the crew's rescue effort was performed in a safe and timely manner. The response time by professional emergency medical services was timely.</p>	<p>No recommendation.</p>
Investigative Readiness	
<p>F2: The Board found that the delay in appointing an Accident Investigation Board resulted in difficulties with collecting evidence, conducting interviews, and securing and preserving the scene.</p>	<p>R1: The Board recommends that Bonneville Power Administration (BPA) evaluate the need to include contractor accidents into the BPA protocol for investigations.</p>

Findings	Recommendations
Medical Analysis/Fitness for Duty	
<p>F3: The Board requested but was not provided medical information to base any conclusions on Wilson Construction Company (WCC) Crew Foreman 2's (CF2's) medical state, fitness for duty or official cause of death.</p>	<p>R2: The Board recommends that BPA's Medical Officer assess the medical information for CF2 if received.</p> <p>R3: The Board recommends that BPA's Contracting Office insert language in all master contracts and contract releases that explicitly states that if requested, BPA's Medical Officer be provided all relevant medical information as soon as it becomes available in the event of a BPA Contractor injury or fatality.</p>
General Contractor Project Communication Process	
<p>F4: The Board found there is not a clear understanding that all personnel have the authority to temporarily suspend work due to imminent danger or safety issues.</p>	<p>R4: The Board recommends that BPA's Contracting Office insert language in all master contracts and contract releases that explicitly states that all personnel have the authority to temporarily suspend work due to imminent danger or safety issues without the fear of reprisal.</p>
Wilson Construction Company Safety Management Processes – Wilson Safety Manual	
<p>F5: The Board found that while the job briefing and THA completed on the day of the accident met the requirements of WCC's Safety Manual, Section 3, the job briefing entries on the THA under Hazard Control Measures were not performed by Crew 2 at worksite B447.</p>	<p>R5: The Board recommends that WCC Management implement a process to ensure all workers follow the documented hazards control measures on the THA, as written and signed.</p>
<p>F6: The Board found that THAs reviewed for the month of July had instances of incompleteness and lacked the rigor expected for the line work being performed.</p>	<p>R6: The Board recommends that WCC needs to establish and enforce expectations for conducting THAs in a thorough and professional manner.</p>
<p>F7: The Board found that CF2 conducted the job briefing as opposed to WCC Crew Foreman 1 (CF1), who was the Clearance Holder. This was contrary to established contract requirements that the Clearance Holder shall conduct the job briefing.</p>	<p>R7: The Board recommends that WCC Management implement a process to ensure that the Clearance Holder conducts the job briefing as per contract requirements.</p>

Findings	Recommendations
Wilson Construction Company Safety Management Processes – Responsibility for Safety	
<p>F8: Based on the information presented, the Board found that the difference of opinion between CF2 and WCC Journeyman Lineman 1 (JL1) should have been elevated to the WCC Site Superintendent (SI) for resolution. Even though a follow-up discussion between CF2 and JL1 occurred, the discussion did not result in adequate grounding and bonding to establish an Equipotential Zone (EPZ) at Crew 2’s work location but did end with a determination to ground it differently.</p> <p>F9: The Board found that the SI left Geisel immediately after the job briefing. The Board determined if the SI had been involved with the follow-up discussion between CF2 and JL1 at Geisel, the EPZ differences of opinion should have been resolved.</p> <p>F10: The Board found that the WCC Quality Assurance/Quality Control/Safety Auditor (QA/QC) was not engaged in the work at the Geisel worksite and left the worksite prior to the discussion between CF2 and JL1. The Board determined if the QA/QC had been involved with the follow-up discussion between CF2 and JL1 at Geisel, the EPZ differences of opinion should have been resolved.</p> <p>F11: Based on the information presented, the Board found that there was no one person in charge of the worksite after the SI left the work location. Even though there was another crew foreman at the scene who was also the Clearance Holder, there was no clear delegation of authority. Having one clear person in charge could have resolved the EPZ differences between CF2 and JL1.</p>	<p>R8: The Board recommends that WCC management establish a clear delegation of authority at work locations when the SI is not physically present to make decisions.</p>

Findings	Recommendations
<p>F12: The Board found that the automated external defibrillator (AED) was not available at the accident scene immediately after the accident.</p>	<p>R9: The Board recommends that WCC management evaluate the need for additional AEDs or establish a protocol to make sure the device is on-site with the crews.</p>
<p>Wilson Construction Company Safety Management Processes – Site Specific Safety Plan</p>	
<p>F13: The Board found that Crew 2 did not install a ground between 46/5S and the driven ground rod, thus failing to establish an EPZ between all the conductive parts at their worksite.</p> <p>F14: The Board found that neither Crew 1 nor Crew 2 installed master grounds between either of their work locations (B447 or B461) and the Geisel Monument Tap section.</p>	<p>R10: The Board recommends that WCC management ensure all workers follow the documented grounding procedures outlined in WCC’s Safety Manual and the Site Specific Safety Plan (SSSP) posted on-site.</p> <p>R11: The Board recommends that WCC management establish and implement a formal training program on all grounding processes and procedures.</p>
<p>F15: The Board found that grounds on 46/5 were not applied under the direction of the Clearance Holder.</p>	<p>R12: The Board recommends that WCC management implement a process to ensure that the Clearance Holder directs the application of protective grounds as per the Contractor Clearance, Hold Order and Work Permit Procedure.</p>
<p>Jacobs Safety Management Responsibilities</p>	
<p>F16: The Board found that conflicts in the Terms and Conditions within the Master Contract and between the Master Contract and Contract Release 100 resulted in ambiguity for the Jacobs Quality Assurance Representative (QAR)’s roles and responsibilities for safety.</p>	<p>R13: The Board recommends that BPA’s Contracting Office reviews all contracts to remove contradictions in roles and responsibilities of the contractor.</p>
<p>Training</p>	
<p>F17: The Board was not provided sufficient evidence to determine if CF2 possessed all the necessary skills or knowledge to perform the work safely. However, with the limited evidence provided, the Board found that on the day of the accident, CF2 did not establish an EPZ.</p>	<p>R14: The Board recommends that WCC management establish and implement a formal training program which requires that workers demonstrate proficiency on all grounding processes and procedures.</p>
<p>Post Accident Modeling</p>	
<p>F18: Through engineering modeling and on-site testing, the difference of potential was sufficient to be hazardous; the Board determined that the creation of an EPZ at 46/5 would have mitigated the hazard.</p>	<p>R15: The Board recommends that WCC line crews continuously monitor step and touch voltages and establish and work within an EPZ.</p>

1. INTRODUCTION

1.1. About Bonneville Power Administration

The Bonneville Power Administration (BPA) is a U.S. Federal agency based in the Pacific Northwest. BPA was created by an act of Congress in 1937 to market electric power from the Bonneville Dam located on the Columbia River and to construct facilities necessary to transmit that power. Congress has since designated BPA to be the marketing agent for power from all of the Federally-owned hydroelectric projects in the Pacific Northwest. Bonneville is one of four regional Federal Power Marketing Administrations (PMA) within the U.S. Department of Energy (DOE) and is headquartered in Portland, Oregon.

The BPA's mission as a public service organization is to create and deliver the best value for its customers and constituents as it acts in concert with others to ensure the Pacific Northwest:

- An adequate, efficient, economical and reliable power supply;
- A transmission system that is adequate to the task of integrating and transmitting power from Federal and non-Federal generating units, providing service to BPA's customers, providing interregional interconnections, and maintaining electrical reliability and stability; and
- Mitigation of the Federal Columbia River Power System's impacts on fish and wildlife.

1.2. Transmission Engineering Services

Transmission Engineering Services supports the expansion, maintenance, and operation of BPA's transmission-related facilities. The organization consists of five separate and distinct work areas:

- Transmission Line Design;
- Civil and Structural Design;
- Transmission Line Maintenance Technical Services;
- Project Engineering; and
- Construction Management and Specifications.

Collectively, these groups provide a wide range of services that focus on the design, construction, and maintenance of transmission and fiber optic lines. Design and construction services are also provided in support of outdoor substation needs such as site development, structural components, and strain bus and in support of the Wireless Program.

1.3. Wilson Construction Company

Wilson Construction Company (WCC) was founded in 1952, with its headquarters in Canby, Oregon. WCC specializes in the construction of overhead and underground electrical distribution and transmission power lines through 500kV for utilities and power providers across

the United States. They are one of the few independently owned and managed firms that performs all facets of electric distribution, transmission and substation construction projects, from installing the meter for a home to interconnecting high voltage lines to the local power plant. WCC expertise includes all types of underground construction including voltages up to 345kV, overhead transmission lines to 500kV, and substations and switchyards from distribution to 500kV.

WCC currently maintains offices in Washington, Oregon, Arizona, and California.

WCC is currently part of an Outsource Construction Services Contract Pool with BPA to perform transmission line related construction projects.

1.4. Jacobs Engineering Group Inc.

Founded in 1947, Jacobs Engineering Group Inc. (Jacobs) is one of the world's largest and most diverse providers of technical, professional, and construction services, including all aspects of architecture, engineering and construction, operations and maintenance, as well as scientific and specialty consulting. It serves a broad range of companies and organizations, including industrial, commercial, and government clients across multiple markets and geographies. As a broad-based technical professional consulting firm, it offers a complete range of services to help clients maintain a competitive edge in their respective markets.

Jacobs is headquartered in Pasadena, California.

Jacobs is currently operating under a master contract with BPA to provide construction administration and inspection services for transmission, substation, telecommunication, and non-electric facility construction projects.

1.5. Aerotek

Aerotek was founded in 1983 to service its recruiting and staffing needs for the aerospace and defense industry. Aerotek expanded their services to provide recruiting and staffing to many additional industries focusing on technical, professional and industrial staffing. Aerotek supplies professional staff to BPA to supplement internal resources.

2. FACTS AND ANALYSIS

1.1. Description of Work Activity

On October 22, 2010, Jacobs was awarded Contract No. 48803, Release 008 to provide on-site construction administration and inspection services for the rebuild and replacement of the Bandon-Rogue No. 1 115kV transmission line project. The performance period for this release was December 21, 2010 to November 30, 2011.

On December 21, 2010, BPA awarded Contract No. 47470, Release 003 to WCC for the Bandon-Rogue No. 1 115kV line rebuild project. The project was for the rebuild of miles 1 through 46 of the Bandon-Rogue No. 1 115kV transmission line. Work included removal of all existing structures, components, guys, anchors, and conductors. Installation work included new poles, guys, anchors, steel cross braces, steel wide-flange cross arms, insulators, line hardware, and the replacement of the conductor. This work included upgrades to existing switches located in miles 4, 15, 24, and 46. Additional project work included improvement and maintenance of access roads (where necessary), and disposal of removed components. The performance period was December 21, 2010 to December 01, 2011.

Following the completion of the work for the release above, BPA determined there was warranty work that needed to be completed to correct workmanship deficiencies in the original construction. It was decided to have this work completed in two parts due to the long lead times for some of the materials and limited access to the site due to weather conditions. WCC submitted their plans for this two-part work.

It was also determined by BPA Transmission Design staff that the switch stands in miles 4, 15, 24, and 46 were incorrectly located in relation to the transmission structures. The switch stands would need to be moved to secure proper clearances for future maintenance activities and safe operation of the switches. BPA had determined that the original drawings showed incorrect offsets for the switch stands of five feet while the proper offset should have been seven feet. The drawings were corrected and WCC was awarded the corrective work. The corrective work was to be done concurrent with the warranty work.

On June 26, 2013, BPA awarded Contract Release 017 to WCC to perform corrective work on the switch structures located in miles 4, 15, 24, and 46 of the Bandon-Rogue No. 1 115kV transmission line. Work included switch stand relocation at 4/4S, 4/5S, 15/2S, 15/3S, 24/9S, 46/5S and 46/6S. Also included was the insertion of additional guy strain insulators at structures 25/1 and 25/5. The performance period for this work was July 8, 2013 to September 13, 2013.

On July 9, 2013, Jacobs was awarded Contract Release 100 to provide on-site construction administration and inspection services for the corrective work to the switches on the Bandon-Rogue No. 1 115kV transmission line. Work included:

- Facilitate and document weekly project meetings;

-
- Assist Construction Manager with change order documentation requirements and Request for Information (RFI) responses;
 - Ensure quality control program is followed as specified;
 - Provide one Resident Engineer and one Quality Assurance Representative;
 - Attend daily tailboard meeting with the contractor;
 - Document inspection on the Contract Administration Information System site;
 - Assist BPA Construction Manager with contract closeout requirements;
 - Ensure contractor's compliance with contract requirements;
 - Report all non-compliance to the Construction Manager;
 - Facilitate project communications and documentation;
 - Perform Quality Assurance (QA) to monitor and report construction contractor compliance with all applicable contract requirements; and
 - Contractor shall not provide direction to the construction contractor in the performance of its work and/or act as a consultant to the construction contractor.

The performance period for this release was July 8, 2013 to October 18, 2013.

The specific work required at structure 46/5 and 46/6 included relocating switch stands 46/5S and 46/6S (Figure 1), two additional feet away from their respective transmission structures and two additional feet away from the Geisel Monument Substation fence.

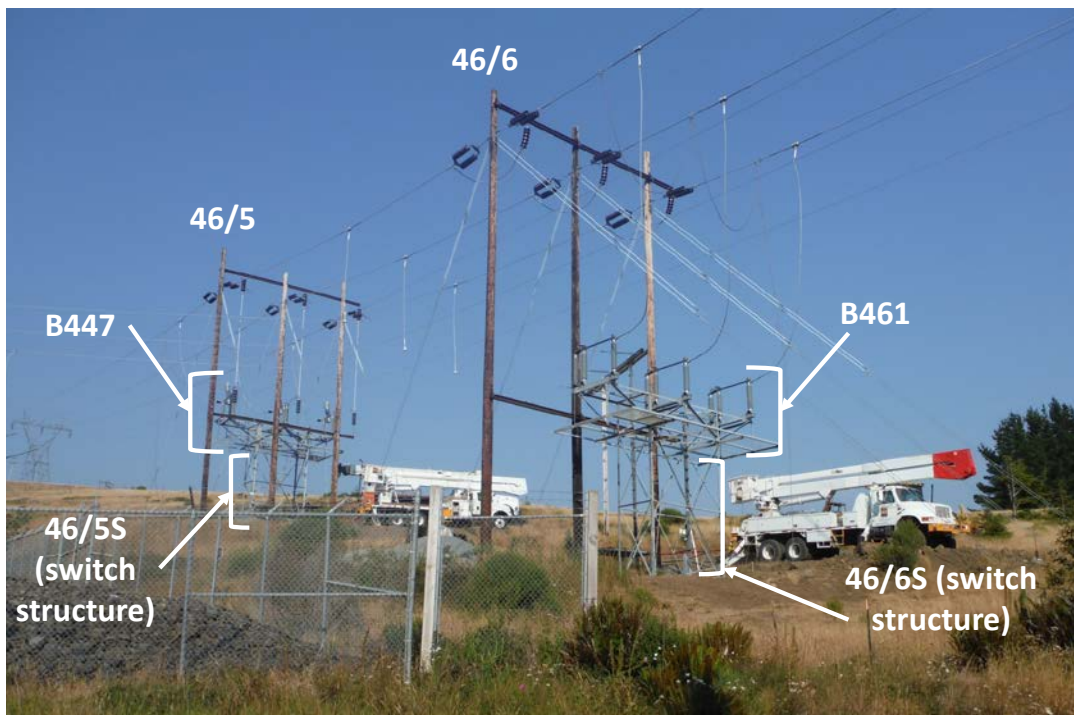

Figure 1: Geisel Monument Worksite

In addition, new vertical risers were to be installed from the bottom cross arm to the upper cross arm on each structure and the horizontal jumpers from the bottom cross arm to the switch were to be replaced with a higher capacity conductor (Figure 2). Jumpers from the overhead line to the harp end of the switch were to remain in place as constructed in the original release.

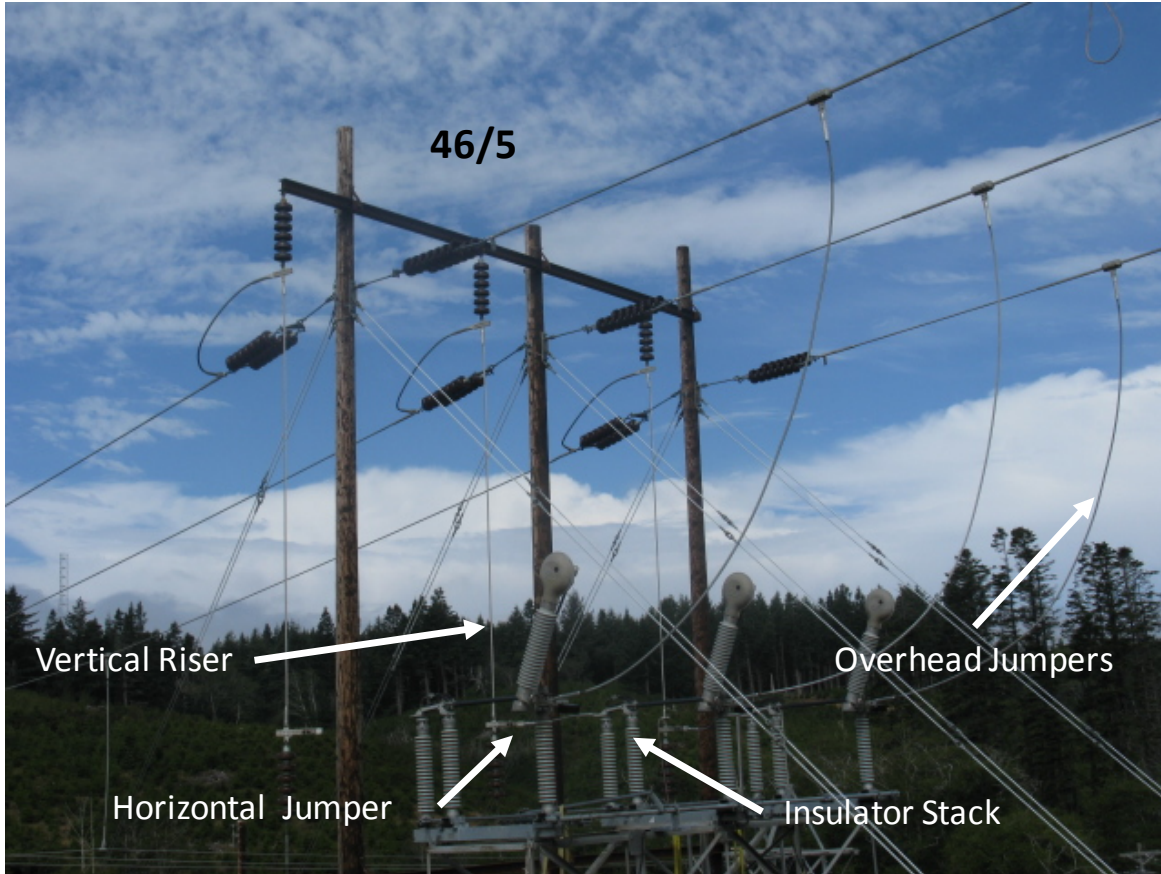

Figure 2: Riser and Jumper Location on Structure 46/5

2.1. Description of the Accident

On July 29, 2013, at 1854, the Wilson Crew Foreman 1 (CF1) received a Work Clearance from BPA's Munro Control Center (MCC) Dispatcher. All three terminals of the Port Orford-Rogue section including the Geisel Monument Tap were cleared and tagged. The ground switch at Rogue Substation was closed; the Coos-Curry ground switch at Geisel Monument was open; and there was no ground switch at Port Orford Substation.

On July 30, 2013, at approximately 0700, the WCC work crews assembled at their materials yard located near U.S. Route 101 on Cape Blanco Road in Curry County, Oregon. A general safety meeting was conducted. Personnel attending were the Wilson Site Superintendent (SI), Wilson Quality Assurance/Quality Control/Safety Audit Manager (QA/QC), Wilson Crew Foremen 1 and 2 (CF1 and CF2), Wilson Journeyman Linemen 1 and 2 (JL1 and JL2), and Wilson Equipment Operators 1 and 2 (EO1 and EO2). The Jacobs Company was represented by Jacobs Quality Assurance Representative (QAR2), his first day on this job. Jacobs Quality Assurance

Representative (QAR1) left on vacation after introducing QAR2 to the crews. An Aerotek Construction Manager (CM) was also in attendance.

The task hazard analysis (THA) covers the hazards associated with the tasks the work procedures involved, special precautions, energy sources, personal protective equipment requirements, hazard elimination or control measures, and the Emergency Action Plan for the site. Each employee and any visitors to the worksite must sign the THA to verify that they have reviewed and understand the hazards.

*WCC Safety Manual,
February 2013*

Following the general meeting, CF1 and CF2 discussed grounding for the Geisel worksite. They decided to finish the discussion following the job briefing at Geisel before work commenced. After gathering tools, materials and trucks, the crews traveled to the Geisel worksite.

The SI left the Cape Blanco Road material yard and traveled to another location prior to arriving at the Geisel site. At approximately 0830, following the job briefing, SI left the Geisel site for another location to assist in unloading materials from a truck.

Upon arrival at the Geisel worksite at approximately 0800, the crews conducted the job briefing of the specific work hazards and how the work was to be performed. The plan of the day was for the six men to break into two crews for work on their respective switch at 46/5 and 46/6. Crew 1 was at structure 46/6 and Crew 2 at structure 46/5. (Figure 3)



Figure 3: Aerial View of the 46/5 and 46/6 Structures at the Geisel Monument Tap

Each switch was to be relocated diagonally to provide better clearance between the down guys and the switch jumpers. Risers and sectionalizing jumpers were to be rebuilt at each switch.

The Geisel worksite encompasses structures 46/5 with switch B447 and 46/6 with switch B461 on the Bandon-Rogue No. 1 115kV line. These structure numbers define that the structures are 46 miles from Bandon Substation and are the fifth and sixth structures in mile 46. They are also approximately 0.41 miles from the Rogue Substation. The de-energized Port Orford-Rogue section of the Bandon-Rogue No. 1 115kV line was in proximity to the energized Fairview-Rogue No. 1 230kV line. 46/5S and 46/6S are the steel support structures.

After completing the job briefing, CF1 and CF2 continued their discussion on how they planned to ground at their respective work locations. CF1 believed that the discussion was complete.

As the crews split for work, JL1 felt he needed to have another grounding discussion with CF2. After the follow up discussion, JL1 believed that he had gained agreement with CF2 but as he left to get to work, JL1 again heard CF2 express a difference of opinion on how it was to be grounded. Neither JL1 nor CF2 elevated the difference of opinion to the SI for resolution. After a short discussion about CF2's opinion, CF1 and JL1 began to isolate the 46/6 worksite from the 46/5 worksite by getting their conductor jumpers open. CF1 placed emphasis on getting grounded and getting isolated.

A three phase ground set was installed on the overhead line above the worksite at 46/6 by Crew 1. A step and touch¹ voltage measurement was taken at the 46/6 worksite. Crew 1 established an equipotential zone (EPZ)¹ between the 46/6S switch structure, the B461 sectionalizing switch, the 46/6 wood pole down ground, the driven ground rod, and the 115kV transmission line.

¹ See Appendix E Glossary for the OSHA definitions of step and touch and EPZ.

A three phase ground set was installed on the overhead line above the worksite at 46/5 by Crew 2. There was no step and touch voltage measurement taken at the 46/5 ground rod. No EPZ was established by Crew 2 at 46/5 because they did not bond the driven ground rod to 46/5S. (Figures 4 and 5) The tap into Geisel Monument was left ungrounded as neither crew installed a master set of grounds on the tap line.

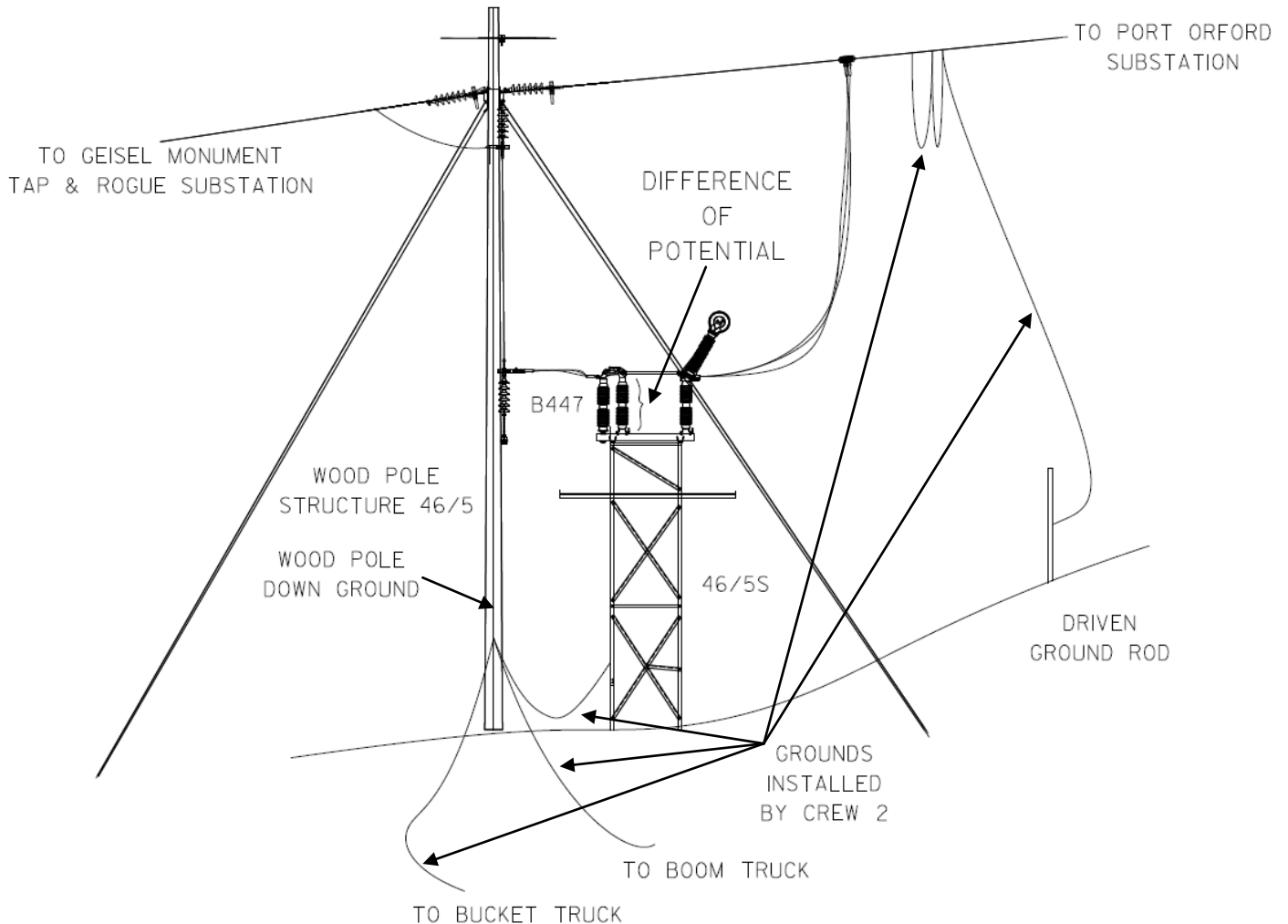

Figure 4: Grounds Installed by Crew 2 at Worksite 46/5

By about 0930 at structure 46/5, JL2 was in the bucket truck removing the sectionalizing jumper on A-Phase when CF2 climbed up to the top of the switch stand to attach lift slings suspended from the crane. Once the lift slings were placed and pulled up snug, CF2 positioned himself at the east side of the center switch to assist JL2 in the removal of the blade end sectionalizing jumper on B-Phase.



Figure 5: Structure 46/5S Switch B447

At approximately 0945, CF2 made contact with a difference of potential across the blade end insulator stack on B447.

2.1.1. Accident Response

At 46/5, JL2 and EO2 heard CF2 yell and saw that CF2 was being shocked. JL2 began jumping up and down in the bucket truck and yelling to get help and to call 911. At 46/6, JL1 and CF1 heard the yelling but could not tell what the commotion was all about. EO2 yelled, “*We have a man on fire!*” EO1 called 911 and EO2 began clearing the driveway into the site for the Emergency Medical Services (EMS) vehicles to access the worksite.

JL2, operating a bucket truck, positioned his jib’s load line above CF2, who was lying over backwards, belted to the rotating insulator stack on B-Phase. CF1 climbed the switch structure, attempted cardiopulmonary resuscitation (CPR) and rigged CF2 to the jib line for rescue. CF2 was lowered to the ground and repositioned by JL1 who began CPR with other crew members assisting. CPR was performed until the EMS personnel arrived on the scene. The EMS’ automated external defibrillator (AED) was used. CF2 was transported by ambulance at 1010. CF2 was pronounced dead at 1051 at Curry General Hospital in Gold Beach, Oregon.

2.2. Chronology of Events

Table 1 provides a brief chronology of significant events leading up to the accident. The fully developed chronology is included with the causal and events analysis in Appendix D.

Table 1: Chronology of the Accident

Time	Significant Events Leading to the Accident of July 30, 2013
07/08/2013	Contract Release for corrective switch work on Bandon-Rogue issued to Wilson Construction Company (WCC).
07/30/2013 ~0800	Personnel arrived at the Geisel worksite: Wilson Site Superintendent (SI), Wilson Quality Assurance/Quality Control/Safety Audit Manager (QA/QC), Wilson Crew Foremen 1 and 2 (CF1 and CF2), Wilson Journeyman Linemen 1 and 2 (JL1 and JL2), and Wilson Equipment Operators 1 and 2 (EO1 and EO2); Jacobs Quality Assurance Representative (QAR2) and Aerotek Construction Manager (CM).
07/30/2013 0815-0830	The job briefing and Task Hazard Analysis (THA) discussed at Geisel included everyone except QA/QC.
07/30/2013 0830	Immediately after the job briefing, SI left Geisel enroute to Cape Blanco material yard to assist in unloading a truck.
07/30/2013 ~0830	CF2 and JL1 had a discussion about grounding and establishing an EPZ.
07/30/2013 ~0900	Crew 2 started work at worksite 46/5.
07/30/2013 ~0915	CF2 and JL2 grounded line for work on B447.
07/30/2013 ~0930	JL2 removed A-Phase sectionalizing jumper from B447.
07/30/2013 ~0930	CF2 climbed switch structure 46/5S to attach lift slings.
07/30/2013 ~0945	CF2 positioned and belted to the blade end insulator stack to assist in B-Phase jumper removal from B447.
07/30/2013 ~0945	CF2 made contact with a difference of potential across the blade end insulator stack of B447.
07/30/2013 ~0945	Electrical Shock

2.3. Emergency Response and Investigative Readiness

2.3.1. Emergency Response

Immediately after CF2 made contact with a difference of potential across disconnect switch structure 46/5S and B447, JL2 heard CF2 yell out and turned to see CF2 “hung up” on the switch. EO2 looked up and saw an arc between CF2’s leg and the bottom of the switch. EO2 yelled out “*We have a man on fire!*” and began to summon help at that location. EO2 went to grab the GPS coordinates from the THA so he could contact 911.

At the same time CF1, JL1 and EO1, who were working on disconnect switch structure 46/6S, saw JL2 jumping up and down in the bucket truck and heard JL2 yelling for help. CF1 instructed EO1 to call 911. EO1 used the THA for coordinates with JL1 assisting while CF1 grabbed his harness and ran up the hill to help. EO2 began moving vehicles and equipment, clearing a location for an ambulance and potential helicopter landing. QAR2, at the bottom of the hill, also heard JL2 yell that a man was on fire, grabbed a fire extinguisher and started up the hill to 46/5S. Once he was able to see that CF1 and JL2 were on their way to CF2’s location and a fire extinguisher was not needed, he stepped back out of the way and began documenting the scene and activities taking place.

CF1 assessed the situation prior to climbing the structure. CF2 had fallen back into his harness and work positioning belt which was attached to the B-Phase rotating insulator stack of B447. CF1 assessed that he needed to stay below the live parts of the disconnect and began climbing to CF2’s location. During this time, JL2 began to position the bucket truck, which was equipped with a small jib crane, next to CF2 in preparation for a rescue. CF1 arrived at CF2’s location and began to evaluate CF2’s condition. CF1 gave CF2 a few rescue breaths and chest compressions but the location and position of CF2 on structure 46/5S made it difficult to perform CPR.

Both CF1 and JL2 rigged CF2 to the jib crane and freed him from the insulator stack. JL2 positioned the bucket truck away from the disconnect structure and lowered CF2 to the ground where JL1 was waiting. CF2 was unhooked from the jib line by JL1 and positioned so that CPR could be performed. An AED was unavailable at the worksite, as it was located offsite in SI’s vehicle.

JL1 began giving rescue breaths and CF1 began giving chest compressions. This continued with JL1 switching to compressions and JL2 giving rescue breaths until EMS personnel arrived at 1005. EMT’s applied an AED. CF2 was shocked with the AED before being loaded onto a backboard and stretcher and taken down the hill to the awaiting ambulance. CF2 was loaded into the ambulance and the EMS left the scene at 1010. CF2 was taken to Curry General Hospital where he was pronounced dead at 1051. At 1056, the Curry County Sheriff and QAR2 notified the rest of the crew that CF2 had passed away.

Table 2 provides a brief chronology of the significant activities during the rescue. The fully developed chronology is included as Appendix D.

Table 2: Chronology of Rescue Activities

Date/Time	Rescue Activities
07/30/2013 ~0945	CF2 made contact with a difference of potential across the blade end insulator stack of B447.
07/30/2013 ~0945	JL2 heard CF2 yell.
07/30/2013 ~0945	EO2 looked up and saw an arc between CF2's leg and switch structure.
07/30/2013 ~0945	CF1 heard JL2 yell and told EO1 to call 911.
07/30/2013 ~0946	JL1 also heard JL2 yell and assisted EO1 with 911 call.
07/30/2013 ~0946-0950	CF1 ran to CF2's location to assist.
07/30/2013 ~0946-0950	CF1 climbed switch structure to perform rescue.
07/30/2013 ~0946-0950	JL2 positioned bucket truck with jib crane next to CF2.
07/30/2013 ~0946-0950	EO2 cleared area for ambulance and potential helicopter landing.
07/30/2013 ~0946-1010	QAR2 ran to CF2's location and began documenting accident scene.
07/30/2013 ~0946-1000	CF1 performed rescue breaths and chest compressions on CF2 in the structure 46/5S.
07/30/2013 ~0946-1000	CF1 and JL2 rigged and lowered CF2 to the ground with jib crane.
07/30/2013 ~0946-1000	JL1 positioned CF2 on the ground and began CPR.
07/30/2013 ~0946-1005	CF1 and JL2 assisted in CPR until EMS personnel arrived on the scene.
07/30/2013 1005	EMS personnel arrived on-site.
07/30/2013 ~1005-1010	EMS personnel applied the AED and shocked CF2.

Date/Time	Rescue Activities
07/30/2013 1010	EMTs loaded CF2 into ambulance and transported CF2 to Curry General Hospital.
07/30/2013 1051	CF2 pronounced dead at the hospital.
07/30/2013 1056	Curry County Sheriff on-site was notified.
07/30/2013 1056	Sheriff and QAR2 notified crew that CF2 had passed away.

FINDING 1: The Board found that the crew’s rescue effort was performed in a safe and timely manner. The response time by professional emergency medical services was timely.

2.3.2. Investigative Readiness

WCC began an investigation into the accident immediately following the rescue and transport of CF2. WCC took statements and made an initial safety assessment of the scene to safely enter and take measurements of step and touch and other voltages and collected documentation for review. The scene was made safe and secured.

A BPA Chief Operator was working at Rogue substation and responded to the scene upon notification of the accident, and a BPA Safety Manager was dispatched to the scene and arrived on the evening of July 30, 2013, to review what happened at the worksite. BPA did not formally establish an Investigation Board until August 7, 2013.

DOE Order (O) 225.1B, *Accident Investigations*,² allows the Power Marketing Administrators to “opt out” of compliance with the requirements of the investigation order. The BPA *Accident Investigation Manual*, Chapter 181 specifically exempts BPA from “any issuance” of the DOE O 225.1A.

The DOE has required through DOE Policy (P) 450.4, *Integrated Safety Management*, and requirements through of DOE O 450.2, *Integrated Safety Management* for DOE and contracting organizations to establish and implement an Integrated Safety Management System. This requirement is codified in Department of Energy Acquisition Regulation Clause 48 CFR 970.5223-1, “*Integration of environment, safety, and health into work planning and execution*,” and is included in DOE contracts. BPA is the only PMA specifically exempted from the policy in DOE P 450.4 and the requirements of DOE O 450.2.

In response to the fatal accident, the DOE Chief, Health Safety and Security Officer, Office of Health Safety and Security, strongly encouraged the Acting BPA Chief Operating Officer to investigate and report.

² Both DOE Order 225.1B and DOE O 225.1A exempt the Bonneville Power Administration.

These conflicting requirements and policies served to delay establishing the Board and mixed authorities to conduct the investigation in an expeditious manner. The outcomes of this delay and unclear roles and responsibilities ultimately hampered custody and control of the accident scene and immediate access to witnesses and documentation used in the work processes. Due to difficult communication channels on the part of BPA and the contractors involved, the Board was unable to interview key witnesses and ascertain critical information pursuant to the investigation.

The Board could not determine the final impacts this may have had on the investigation.

FINDING 2: The Board found that the delay in appointing an Accident Investigation Board resulted in difficulties with evidence collection, conducting interviews, and securing and preserving the scene.

RECOMMENDATION 1: The Board recommends that BPA evaluate the need to include contractor accidents into the BPA protocol for investigations.

2.4. Medical Analysis/Fitness for Duty

The Board requested but was not provided with medical evidence or clinical diagnoses to substantiate that there were, in fact, no fitness for duty issues and/or concerns relative to CF2's state of health that may have had a contributing factor in this accident. The Board was notified that if an autopsy had been completed, the results would not be available for four to six weeks.

FINDING 3: The Board requested but was not provided medical information to base any conclusions on Wilson Construction Company (WCC) Crew Foreman 2's (CF2's) medical state, fitness for duty or official cause of death.

RECOMMENDATION 2: The Board recommends that BPA's Medical Officer assess the medical information for CF2 if received.

RECOMMENDATION 3 The Board recommends that BPA's Contracting Office insert language in all master contracts and contract releases that explicitly states that if requested, BPA's Medical Officer be provided all relevant medical information as soon as it becomes available in the event of a BPA Contractor injury or fatality.

3. WORK PROCESSES AND CONTROLS

3.1. General Contractor Project Communication Process

The goal of the general contractor project communication process is to provide a consistent structure for all outsourced construction services to resolve field questions at the lowest level in the fastest time. The Project Communication Diagram (Figure 6) reflects the preferred route to have questions answered by qualified personnel. Project Communication Diagrams are created for each project release.

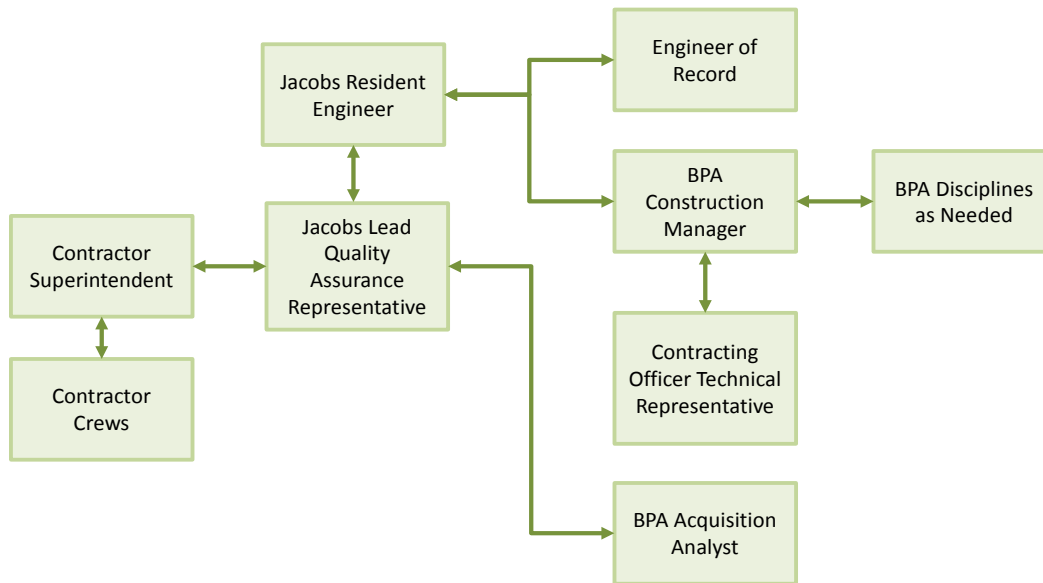

Figure 6: General Contractor Project Communication Diagram

The Superintendent is the first line for field questions on the project. If the answer to a question cannot be determined by the Superintendent, the question is passed on to the Quality Assurance Representative. Questions regarding field issues, safety, or material issues can often be resolved at this level.

The Quality Assurance Representative can direct material quantity questions to the BPA Acquisition Analyst for resolution directly. In the event the Quality Assurance Representative requires additional support, Requests for Information are elevated to the Jacobs Resident Engineer who will post the questions to the Contract Administration Information System (CAIS) and notify the appropriate responder via email, either the Construction Manager or the Engineer of Record for the project design. The Construction Manager notifies the COTR and forwards the question to the appropriate discipline at BPA.

All issues and Requests for Information sent to the Resident Engineer are logged on an issue report and discussed at the weekly progress meetings. These items are discussed at the weekly meeting until resolved.

FINDING 4: The Board found there is not a clear understanding that all personnel have the authority to temporarily suspend work due to imminent danger or safety issues.

RECOMMENDATION 4: The Board recommends that BPA's Contracting Office insert language in all master contracts and contract releases that explicitly states that all personnel have the authority to temporarily suspend work due to imminent danger or safety issues without the fear of reprisal.

3.2. Wilson Construction Company Safety Management Processes

WCC performs audits, inspections, training, and manages its safety processes through policies and manuals. These policies and manuals explain in detail WCC's expectations of how WCC employees are expected to perform work safely. The Board reviewed the policies and manuals which were relevant to the work being performed at the time of the electrical contact.

3.2.1. Wilson Safety Manual

The WCC Safety Manual contains the mandatory minimum requirements for dealing with the principal hazards inherent in daily work activities. In the course of the investigation, the Board found three areas of the WCC Safety Manual that were relevant to the accident. These areas, in order of the work to be performed, were:

- Section 3, Job Briefing;
- Section 1, Responsibility For Safety; and
- Section 11, Grounding.

3.2.1.1. Job Briefing

WCC Safety Manual Section 3 covers job briefings and states "*Job briefings shall be performed to provide a uniform methodology and outline key components of tasks.*" Job briefings must:

- *Define the task;*
- *Identify the work procedures involved;*
- *Identify roles and responsibilities;*
- *Identify hazards involved;*
- *Identify Personal Protective Equipment to be used;*
- *Determine the Emergency Action Plan, including physical job location/address;*

-
- *Identify energy sources and energy source controls;*
 - *Include “insulate and/or isolate” method(s) to be used; and*
 - *Determine risk mitigation measures.*

Wilson requires that the employee in charge (e.g., Supervisors) conduct job briefings (tailboard meetings) for all employees involved before the start of the first job of each work shift.

Job briefings shall be documented on the THA form provided by WCC.

The WCC Outsource Construction Services Master Agreement states:

Safety and Health – Line Construction (15-50M) (Dec10) (BPI 15.2.1)

8. *Special Requirements for work on normally energized lines and equipment that are separated by an isolating device under the provisions of a Work Clearance.*
 1. *The Clearance Holder shall hold a detailed daily job briefing and hazard analysis for each crew working under the provisions of his Work Clearance. Any time conditions change, a new job briefing must be held with all affected crew members.*

Through the documented THA, employee statements, and employee interviews, the Board concluded that the crew held and documented a job briefing. The Board concluded that the job briefing reflected the day’s task breakdown, and as a result, the potential hazards and hazard control measures for each.

Although the job briefing was documented, the Hazard Control Measures of “*test with meter, install proper EPZ grounds*” for the Task Breakdown of “*isolate-test-ground Bandon-Rogue 115kV*” were not performed by Crew 2 working on B447. The Hazard Control Measures were followed by Crew 1 working on B461.

FINDING 5: The Board found that while the job briefing and THA completed on the day of the accident met the requirements of WCC’s Safety Manual, Section 3, the job briefing entries on the THA under Hazard Control Measures were not performed by Crew 2 at worksite B447.

RECOMMENDATION 5: The Board recommends that WCC Management implement a process to ensure all workers follow the documented hazards control measures on the THA, as written and signed.

FINDING 6: The Board found that THAs reviewed for the month of July had instances of incompleteness and lacked the rigor expected for the line work being performed.

RECOMMENDATION 6: The Board recommends that WCC needs to establish and enforce expectations for conducting THAs in a thorough and professional manner.

FINDING 7: The Board found that CF2 conducted the job briefing as opposed to WCC Crew Foreman 1 (CF1) who was the Clearance Holder. This was contrary to established contract requirements that the Clearance Holder shall conduct the job briefing.

RECOMMENDATION 7: The Board recommends that WCC management implement a process to ensure that the Clearance Holder directs the application of protective grounds as per the Contractor Clearance, Hold Order and Work Permit Procedure.

3.2.1.2. Responsibility for Safety

Section 11 of Wilson's Safety Manual states the following:

GENERAL

The safety and health of all employees of this company is of primary importance. The prevention of work related injuries and illnesses is of such high importance that it takes precedence over production.

Wilson pledges to work diligently and conscientiously to promote safe and healthful conditions and expects equal diligence from all employees in the recognition and elimination of unsafe conditions and acts.

Wilson Construction Company shall:

4. *Perform safety audits to identify and eliminate unsafe and unhealthy working conditions and/or practices.*
 - a. *Jobsite safety audits will be performed daily on jobs where on-site safety personnel are stationed. Field Safety Coordinators will perform safety audits when visiting jobsites and crews. The Supervisor shall perform a weekly safety audit for their jobsite. All safety audits will be documented and submitted to the Canby office.*

Supervisors shall:

1. *Be held accountable for all incidents on their job or under their supervision.*
3. *Be responsible, at all times, to see that work is performed in a safe manner and safety policies and procedures are followed.*
5. *Make sure that PPE, safety equipment, and first aid supplies are provided wherever and whenever necessary.*
8. *Be knowledgeable of the safety and health hazards to which employees under their immediate direction and control may be exposed.*

EMPLOYEE RESPONSIBILITY:

Management expects each employee, regardless of his/her position within the organization, to cooperate in every respect with Wilson's Safety Manual.

- 3. Immediately report all unsafe or hazardous conditions or other safety concerns to their Supervisor.*
- 7. Understand the safety and health hazards specific to their job assignment.*
- 8. Before starting a job, employees shall thoroughly understand the work to be done, their part in the work, and the safety rules that apply. If an employee is in doubt about their ability to perform the work, they shall inform their supervisor immediately.*

Through the documented job briefing forms, employee statements, employee interviews and the Wilson Safety Manual, the Board concluded that there were missed opportunities to address the need to adequately ground and establish an EPZ at the worksite at B447.

While the job briefing prior to work commencing addressed the need to test the step and touch voltage and establish an EPZ at B447, JL1 and CF2 had a follow-up discussion on the method to properly ground the worksite. The discussion lasted several minutes after the job briefing but ended with CF2 expressing a difference of opinion on the grounding method. Neither JL1 nor CF2 contacted SI to request a resolution to the difference of opinion. It appeared to the Board that there was no consensus on the way to ground the two worksites which for all practical purposes were identical in nature. This led to Crew 1 installing master grounds along with a ground from the disconnect structure of B461 to the ground rod. This established their EPZ. Crew 2 only installed master grounds and did not establish an EPZ at B447 by connecting the disconnect structure to their driven ground rod. Crew 1 performed a step and touch measurement prior to going to work while Crew 2 did not.

The SI of the job was not on-site at Geisel at the time the discussion between CF2 and JL1 took place. He left after the job briefing to travel to the materials yard to off-load a truck. The crew's AED was in the SI's truck and was not at the worksite at the time of the accident.

The WCC QA/QC was at Geisel at the time the discussion was taking place between CF2 and JL1 but was in his vehicle on a conference call at the time and was thus unaware of any discussion. The QA/QC did not attend the job briefing at Geisel that morning. The QA/QC left the site shortly after the conference call only to return after getting the call that there had been an accident.

FINDING 8: Based on the information presented, the Board found that the difference of opinion between CF2 and JL1 should have been elevated to the SI for resolution. Even though a follow-up discussion between CF2 and JL1 occurred, the discussion did not result in adequate grounding and bonding to establish an EPZ at Crew 2's work location but did end with a determination to ground it differently.

FINDING 9: The Board found that the SI left Geisel immediately after the job briefing. The Board determined if the SI had been involved with the follow-up discussion between CF2 and JL1 at Geisel, the EPZ differences of opinion should have been resolved.

FINDING 10: The Board found that the WCC QA/QC was not engaged in the work at the Geisel worksite and left the worksite prior to the discussion between CF2 and JL1. The Board determined if the QA/QC had been involved with the follow-up discussion between CF2 and JL1 at Geisel, the EPZ differences of opinion should have been resolved.

FINDING 11: Based on the information presented, the Board found that there was no one person in charge of the worksite after the SI left the work location. Even though there was another crew foreman at the scene who was also the Clearance Holder, there was no clear delegation of authority. Having one clear person in charge could have resolved the EPZ differences between CF2 and JL1.

RECOMMENDATION 8: The Board recommends that WCC management establish a clear delegation of authority at work locations when the SI is not physically present to make decisions.

FINDING 12: The Board found that the AED was not available at the accident scene immediately after the accident.

RECOMMENDATION 9: The Board recommends that WCC management evaluate the need for additional AEDs or establish a protocol to make sure the device is on-site with the crews.

3.2.1.3. Grounding

Section 11 of Wilson's Safety Manual states the following:

“Employee protection consists of two components: a Master Ground, and a worksite Equipotential Zone (EPZ). The Master Ground is designed to keep the equipotential work zone from becoming energized any longer than necessary in the event the circuit or equipment becomes energized. The EPZ ensures that employees are protected in case of an energization of the work area. The Master Ground and the EPZ may be at the same location or the Master Ground may be at a remote location from the work area. It is important to understand that BOTH components should be in effect while work is being performed. They are essential to provide the employee with the maximum protection currently available.”

“Master Ground – An intentional connection between an earth potential and a normally current carrying conductor. This connection, which may be achieved by use of a substation or resident ground switch, or a grounding cable, shall have sufficient ampacity to conduct the maximum fault current that may occur if the

conductor becomes energized. A Master Ground remains in place for the duration of work on a de-energized line.”

“Equipotential Zone (EPZ) – A worksite protective area that places all conductive components, including people, at the same electrical potential. This is accomplished by connecting those components together with electrical bonds.”

General Work Practices

The standard method of protection for the employee is installing Master Grounds and creating an EPZ.

- 2. An EPZ shall be created at each worksite so that employees are protected from the maximum available fault current for the line segment being worked.*
- 3. The grounding cluster bar should be in place below the employee’s feet or below where an employee might contact the pole. The EPZ shall include any point an employee might contact while performing work.*
- 5. Note that induction may be present on de-energized lines. Hazardous voltage can exist for several reasons, including from wind, lightning, and nearby energy sources.*

SITE SPECIFIC SAFETY PLAN

Bonneville Power Administration

Bandon-Rogue No. 1 115kV Line Rebuild REVISED July 2, 2013

(4) Portable Protective Grounds

- (A) Qualified Wilson employees shall install a visible, three phase short and ground (Master Ground) in each isolated line section before any employee or equipment comes within the Minimum Approach Distance (MAD) of any de-energized line. ... Until properly grounded, per these requirements, lines or equipment shall be considered energized.*

Contractor Clearance, Hold Order and Work Permit Procedure

V.8 CONTRACTOR CLEARANCE HOLDER RESPONSIBILITIES

A. The CLEARANCE HOLDER

- (3) Shall direct the application of protective grounds in accordance with the Grounding Rules in the contract before allowing any workers to touch or come within the applicable Minimum Approach Distance of normally energized electrical parts. The Clearance Holder shall maintain a log of the location of all grounds installed during the work, the time they were installed and the time they*

were removed. This log shall be given to the at-site COTR upon request.

Through the documented job briefing forms (the THA), photographs, employee statements, and employee interviews, the Board concluded that master grounds were installed by Crew 2 on the Bandon-Rogue No. 1 115kV line section between B659 at Port Orford and B447 at Geisel Monument Tap. Master grounds were installed by Crew 1 on the Bandon-Rogue No.1 115kV line section between the B1861 line and auxiliary bus disconnects at Rogue and B461 at the Geisel Monument Tap. The ground switch at Rogue was closed. These master grounds consisted of two grounds between phases and a third coming from one phase to a driven ground rod.

There was not a set of master grounds installed between B447 and B461 at the Geisel Monument Tap. The crew's intent was to "mac"³ around the jumpers between the two disconnects and the risers to the tap section that needed to be removed. This process utilizes a short ground applied and removed with a hot stick which temporarily shorts around the jumpers that are to be removed and prevents personnel from getting in series with a difference of potential. All isolated line sections including customer feeds must be considered a source, and master grounds must be installed before workers come in contact with normally energized lines or equipment.

Crew 1 installed a ground from 46/6S and wood pole structure 46/6 to the driven ground rod, thus creating an EPZ between all conductive parts in their work location. Crew 2 did not install a ground between 46/5S, the wood pole structure 46/5, and the driven ground rod. The live parts of disconnect B447 were at one potential through the master grounds and driven ground rod to earth while the disconnect support structure of B447 was at another potential since it was not connected via an EPZ ground back to the driven ground rod.

The de-energized Port Orford-Rogue section of the Bandon-Rogue No. 1 115kV line was in proximity to the energized Fairview-Rogue No. 1 230kV line. Through subsequent system modeling and actual on-site testing following the accident, the Board determined that the difference of potential could have been in excess of 2,800 V between the live parts of disconnect B447 and 46/5S on the day of the accident. By the installation of a ground from 46/5S to the driven ground rod, setting up an EPZ, the voltage would have been significantly reduced.

³ A mechanical load pick up jumper. A mechanical method used for bypassing components when equipment is under repair.

FINDING 13: The Board found that Crew 2 did not install a ground between 46/5S and the driven ground rod thus failing to establish an EPZ between all the conductive parts at their worksite.

FINDING 14: The Board found that neither Crew 1 nor Crew 2 installed master grounds between either of their work locations (B447 or B461) and the Geisel Monument Tap section.

RECOMMENDATION 10: The Board recommends that WCC management ensure all workers follow the documented grounding procedures outlined in WCC's Safety Manual and the Site Specific Safety Plan (SSSP) posted on-site.

RECOMMENDATION 11: The Board recommends that WCC management establish and implement a formal training program on all grounding processes and procedures.

FINDING 15: The Board found that grounds on 46/5 were not applied under the direction of the Clearance Holder.

RECOMMENDATION 12: The Board recommends that WCC management implement a process to ensure that the Clearance Holder directs the application of protective grounds as per the Contractor Clearance, Hold Order and Work Permit Procedure.

3.3. Jacobs Safety Management Responsibilities

The Jacobs Master Contract No. 48803 delegates Jacobs to provide construction audit and inspection services through observation and reporting on all aspects of the master contracts that they are overseeing for BPA. The excerpts from the Jacobs Master Contract and Release 100 note the following responsibilities:

Jacobs Master Contract No. 48803 Statement of Work

B.4 CONSTRUCTION AUDIT REQUIREMENTS

3. Specific Requirements

A. Construction Administration

b. Construction:

- vi. Monitor construction site environmental compliance and site specific safety plans for self and EPC/PC/C contractors; provide documentation to Contracting Officer or Contracting Officer's Technical Representative of any violations.***

B.5 WORK TO BE PERFORMED

- B. Safety: Verify safety requirements are in place as shown in the Site Specific Safety Plan; verify outages are scheduled and hold orders have been put in***

place; verify traffic control is in place and operational, recommend to the BPA Contracting Officer (CO) stoppage of work for safety violations.

B.12 CONTRACTOR'S RESPONSIBILITY

2. *Contractor shall not have control over or charge of and shall not be responsible for construction means, methods, techniques, sequences or procedures, or for safety precautions and programs in connection with the work of each of the Construction Contractors since these are solely the Construction Contractor's responsibility under contract for construction between Owner and Construction Contractor.*
3. *Contractor does not assume any responsibility or liability for the safety of persons or property as may be affected by construction Work, or for compliance with federal, state or local statutes, rules, regulations and codes applicable to the conduct of the construction Work. The Construction Contractors will remain solely responsible for construction safety.*

Contract Release 00100 (July 09, 2013) Statement of Work

Facilitate and document weekly project meetings (one meeting per month will be on site). Assist Construction Manager with change order documentation requirements and RFI responses. Assure quality control program is followed as specified. Provide one Resident Engineer and one Quality Assurance Representative. Attend daily tailboard meeting with the contractor. Document inspection on the CAIS site. Assist BPA Construction manager with contract closeout requirements. Ensure contractor's compliance with contract requirements. Report all non compliance to the Construction Manager. Facilitate project communications and documentation.

Roles and responsibilities of Jacobs are conflicting within the Master Contract and between the Master Contract and the Contract Release 100. A single example of conflicts within the Contract is that while Jacobs is required to “Verify safety requirements are in place as shown in the Site Specific Safety Plan” in Section B.5, Section B.12 relieves Jacobs of “any responsibility or liability for the safety of persons or property as may be affected by construction Work.”

FINDING 16: The Board found that conflicts in the Terms and Conditions within the Master Contract and between the Master Contract and Contract Release 100 resulted in ambiguity for the Jacobs Quality Assurance Representative (QAR)'s roles and responsibilities for safety.

RECOMMENDATION 13: The Board recommends that BPA's Contracting Office reviews all contracts to remove contradictions in roles and responsibilities of the contractor.

3.4. Crew Foreman 2 Training

The Board reviewed the work history and training records of CF2 as provided by WCC. CF2 attended the Northwest Lineman College in Meridian, ID, in 1996, completing his studies and

earning his certificate in December of that year. He has also attended several WCC sponsored training classes, such as:

- Personal Protective Grounding in November 2011;
- Grounding and Rigging class as taught by Harvey Haven in March 2012;
- Fall Protection training in September 2012; and
- Rigging and Signalman certification in September 2012.

According to the BPA Master Contract 47470-000 with WCC:

The Contractor bears sole responsibility for ensuring that all personnel engaged in work related to the contract possess the necessary knowledge and skills to perform their work safely and to otherwise function in compliance with the foregoing criteria.

FINDING 17: The Board was not provided sufficient evidence to determine if CF2 possessed all the necessary skills or knowledge to perform the work safely. However, with the limited evidence provided, the Board found that on the day of the accident, CF2 did not establish an EPZ.

RECOMMENDATION 14: The Board recommends that WCC management establish and implement a formal training program which requires that workers demonstrate proficiency on all grounding processes and procedures.

4. ANALYSIS

This investigation was conducted using the processes described in the *Bonneville Power Administration Manual*, Chapter 181, *Accident Investigation and Reporting* and the *DOE Handbook, Accident Investigation and Prevention Volume 1 - Accident Analysis Techniques* (DOE-HDBK-1208-2012) which provides guidance on the core analytical methods identified in DOE Order 225.1B, *Accident Investigations*. Evidence was gathered through interviews and reviews of documentation and physical evidence to determine the facts of the accident. The facts were analyzed using barrier analysis, change analysis, events and causal factors analysis and root cause analysis. The results of those analyses were validated through verification analysis.

4.1. Barrier Analysis

Barrier analysis is based on the premise that hazards are associated with all tasks. A barrier is any management or physical means used to control, prevent, or impede the hazard from reaching the target (i.e., persons or objects that a hazard may damage, injure, or harm). The results of the barrier analysis are integrated into the events and causal factors chart to support the development of causal factors.

While the Board identified a number of barrier failures, several key barriers were major contributors to the accident:

- The failure to ensure the sectionalizing switch structure and transmission line were at the same electrical potential resulted in an unrecognized difference of electrical potential sufficient to cause serious injury or death;
- The failure to perform the step and touch measurement was a lost opportunity to ensure any hazardous electrical potential on/in the sectionalizing switch structure was identified and corrected by building an EPZ; and
- The failure to follow the hazard control measures in the THA resulted in a failure to create an EPZ that would have mitigated or eliminated the hazard.

Appendix A contains the complete Barrier Analysis of physical and management barriers identified by the Board.

4.2. Change Analysis

Change analysis examines planned or unplanned changes that caused undesirable results related to the accident. This process analyzes the difference between what is normal, or expected, and what actually occurred before the accident. The results of the change analysis conducted by the Board are integrated into the events and causal factors chart to support the development of causal factors.

The Board examined changes relative to the work being performed on the day of the accident and compared that to prior days and or ideal situations and identified several key changes:

- The grounding and bonding installed at worksite 46/5 did not ensure all structures/ components were within an established EPZ and allowed the possibility of uncontrolled and/or unrecognized electrical potential to exist.
- Performing a step and touch measurement could have identified the high electrical potential which existed at worksite 46/5.
- By not following the requirements of the Site Specific Safety Plan (SSSP) and WCC Safety Manual for grounding, bonding and creation of an EPZ, an unrecognized/unidentified electrical potential existed.

Appendix B contains the complete Change Analysis of significant changes identified by the Board. The Change Analysis compliments and reinforces the Barrier Analysis.

4.3. Post-Accident Powerline Modeling of Induced Voltages

The Board requested BPA Transmission Line Engineering Services to estimate the induction on Bandon-Rogue No. 1 115kV from the nearby Fairview-Rogue No. 1 230kV line. A computer model was set up using the appropriate loading factors recorded on the day of the accident. The model was run using BPA’s Steady State, Constant Power computer program.

The computer model estimated the induced open circuit voltage on the 115kV line to remote earth at 3,334V. The computer model also included current estimates for the following resistive values:

Resistance	Current (Milliamps RMS)	Voltage to Remote Earth (Volts)
1,000 Ω	655	655
8,000 Ω	354	2829

The computer model showed hazardous voltage and current values would be expected on the de-energized Bandon-Rogue No. 1 115kV line, unless proper grounding and bonding (establishing an EPZ) was accomplished.

4.3.1. Post-Accident Testing

On August 22, 2013, BPA Transmission Line Engineering Services conducted tests of the Bandon-Rogue No. 1 115kV power lines involved in the accident. The tests were intended to determine and document the induction at worksite 46/5. The tests were witnessed by members of the Board and a representative of WCC.

A Clearance was established on the line using the same isolation conditions as the day of the accident. The Board obtained from WCC a ground rod and grounds similar to those used by WCC on the day of the accident. The driven ground rod was placed as closely as possible to the location and driven to a depth of 20 inches as it was on the day of the accident. The grounding system was established as described through witness testimony and photographs.

The test results showed the highest measured differential potential between the switch structure and the operating portion of disconnect switch B447 was in excess of 2,800V and the available current was greater than the measured value of 0.54 A RMS (540 milliamps).

The step and touch potentials (as measured) decreased very rapidly over the first three feet of distance from the driven ground. At 2,800 V to remote earth, the step potential was approximately 2,680 V and the touch potential was approximately 2,710 V. These values indicated the importance of using the step and touch meters kits and for keeping personnel clear of the driven ground.

About an hour after the testing started, the driven ground rod was generating enough heat to dry the surrounding soil, increasing its resistance to earth and started to arc. The measured resistance of the driven ground rod to remote earth was in excess of 20 kΩ.

The weather on the day of the accident was reportedly clear and warm. On the day of the testing, the weather was foggy with light drizzle. The fog and drizzle would have the overall effect of increasing the leakage currents on the insulators and lowering the potential on the normally energized components of B447.

4.3.2. Post-Accident Test Analysis

OSHA provides guidance on the effects of electrical shock on the human body. The severity and consequence of electric shock are a result of the current that passes through the human body due principally to the body's electrical resistance. It is important to understand the resistance of parts of the human body to electric current. Figure 7 shows the resistance of various parts of the human body⁴:

<u>Body Part</u>	<u>Resistance</u>	
Dry, intact (no cuts or scabs) skin	100,000 – 600,000 ohms	
Wet skin	1,000 ohms	
Within the body	400 ohms	
Ear to ear	100 ohms	

Figure 7: The Human Body Resistance Model

⁴ The Human Body Resistance Model from the OSHA training materials.

From OSHA 3075, 2002 (Revised):

What effect do shocks have on the body?

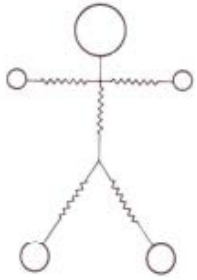
An electric shock can result in anything from a slight tingling sensation to immediate cardiac arrest. The severity depends on the following:

- *the amount of current flowing through the body,*
- *the current's path through the body,*
- *the length of time the body remains in the circuit, and*
- *the current's frequency.*

This table shows the general relationship between the amount of current received and the reaction when current flows from the hand to the foot for just 1 second.

Effects of Electric Current in the Human Body

<i>Current</i>	<i>Reaction</i>
<i>Below 1 milliamperere</i>	<i>Generally not perceptible</i>
<i>1 milliamperere</i>	<i>Faint tingle</i>
<i>5 milliamperes</i>	<i>Slight shock felt; not painful but disturbing. Average individual can let go. Strong involuntary reactions can lead to other injuries.</i>
<i>6–25 milliamperes (women)</i>	<i>Painful shock, loss of muscular control*</i>
<i>9–30 milliamperes (men)</i>	<i>The freezing current or "let-go" range. * Individual cannot let go, but can be thrown away from the circuit if extensor muscles are stimulated.</i>
<i>50–150 milliamperes</i>	<i>Extreme pain, respiratory arrest, severe muscular contractions. Death is possible.</i>
<i>1,000–4,300 milliamperes</i>	<i>Rhythmic pumping action of the heart ceases. Muscular contraction and nerve damage occur; death likely.</i>
<i>10,000 milliamperes</i>	<i>Cardiac arrest, severe burns; death probable</i>

** If the extensor muscles are excited by the shock, the person may be thrown away from the power source.⁵*

⁵ Source: W.B. Kouwenhoven, "Human Safety and Electric Shock," Electrical Safety Practices, Monograph, 112, Instrument Society of America, p. 93. November 1968.

The Board confirmed the results of the computer modeling and the actual measurements taken were in agreement. Both modeling and measurements showed that hazardous voltages and currents could be expected to be present on the de-energized Bandon-Rogue No. 1 115kV line due to the close proximity of the Fairview-Rogue No. 1 230kV line. The presence of this hazardous potential only serves to enforce the need for workers to continuously monitor step and touch voltages and to establish and work within an equipotential zone.

FINDING 18: Through engineering modeling and on-site testing, the difference of potential was sufficient to be hazardous; the Board determined that the creation of an EPZ at 46/5 would have mitigated the hazard.

RECOMMENDATION 15: The Board recommends that WCC line crews continuously monitor step and touch voltages and establish and work within an equipotential zone.

4.4. Events and Causal Factors Analysis

The Events and Causal Factors Analysis is a systematic process that uses methods to determine Causal Factors of an accident. Causal factors are the significant events and conditions that produced or contributed to the **Direct Cause**, the **Contributing Causes** and the **Root Cause(s)** of the accident.

The **direct cause** of an accident is the immediate events or conditions that caused the accident. The Board concluded the direct cause of the accident was that CF2 made contact with a difference of potential across the blade end insulator stack of B447.

Root causes are the causal factors that, if corrected, would prevent recurrence of the same or similar accidents. Root causes may be derived from or encompass several contributing causes. They are higher-order, fundamental causal factors that address classes of deficiencies, rather than single problems or faults. The Board determined the root cause of the accident was Crew 2's failure to establish an EPZ.

Contributing causes are events or conditions that collectively with other causes increased the likelihood of an accident but that individually did not cause the accident. Contributing causes may be longstanding conditions or a series of prior events that, alone, were not sufficient to cause the accident, but were necessary for it to occur.

The Board identified the following Contributing Causes (CC):

- **CC1** - The grounding system installed at worksite 46/5 did not ensure all structures/components were bonded to establish an EPZ. Uncontrolled and unrecognized electrical potential existed.
- **CC2** - Failure to test and monitor step and touch voltage did not identify the high electrical potential which existed at worksite 46/5.

-
- **CC3** - By not following the requirements of the WCC Safety Manual and Site Specific Safety Plan for grounding, bonding and creation of an EPZ, an unrecognized electrical potential existed.
 - **CC4** - Failure to follow the hazard control measures in the THA resulted in failure to create an EPZ and was a lost opportunity for Crew 2 to identify and mitigate any hazardous electrical potential in the work area.
 - **CC5** - A difference of opinion between CF2 and JL1 about the EPZ was not elevated for resolution to the SI and did not result in the establishment of an EPZ at Crew 2's worksite.
 - **CC6** - Absence of the SI from the worksite was a lost opportunity to observe work activities and be available to resolve work practice differences and performance.
 - **CC7** - WCC QA/QC's presence could have resolved the EPZ differences.
 - **CC8** - Structure 46/5 had about 22+ miles of transmission line between the open breaker at Port Orford B659 and the sectionalizing switch B447. The lines coming into 46/5 may have provided a higher probability of induction source.
 - **CC9** - Incorrect initial switch design resulted in BPA needing to initiate corrective actions.
 - **CC10** - Defects in workmanship required WCC to initiate warranty actions.
 - **CC11** - The ungrounded isolated line section of the Geisel Monument Tap section was part of the worksite and should have been included in the EPZ.

5. EXAMINATION OF EVIDENCE

5.1. Findings and Recommendations

The Board determined the facts of the accident and analyzed the facts to determine what happened, why it happened, and what needs to be done to prevent recurrence. The Board used Barrier Analysis, Change Analysis and Causal Factors Analysis to arrive at Findings and Recommendations, which if implemented should prevent a similar accident.

Table 3: Findings and Recommendations

Findings	Recommendations
Emergency Response	
F1: The Board found that the crew’s rescue effort was performed in a safe and timely manner. The response time by professional emergency medical services was timely.	No recommendation.
Investigative Readiness	
F2: The Board found that the delay in appointing an Accident Investigation Board resulted in difficulties with collecting evidence, conducting interviews, and securing and preserving the scene.	R1: The Board recommends that Bonneville Power Administration (BPA) evaluate the need to include contractor accidents into the BPA protocol for investigations.
Medical Analysis/Fitness for Duty	
F3: The Board requested but was not provided medical information to base any conclusions on Wilson Construction Company (WCC) Crew Foreman 2’s (CF2’s) medical state, fitness for duty or official cause of death.	R2: The Board recommends that BPA’s Medical Officer assess the medical information for CF2 if received. R3: The Board recommends that BPA’s Contracting Office insert language in all master contracts and contract releases that explicitly states that if requested, BPA’s Medical Officer be provided all relevant medical information as soon as it becomes available in the event of a BPA Contractor injury or fatality.
General Contractor Project Communication Process	
F4: The Board found there is not a clear understanding that all personnel have the authority to temporarily suspend work due to imminent danger or safety issues.	R4: The Board recommends that BPA’s Contracting Office insert language in all master contracts and contract releases that explicitly states that all personnel have the authority to temporarily suspend work due to imminent danger or safety issues without the fear of reprisal.

Findings	Recommendations
Wilson Construction Company Safety Management Processes – Wilson Safety Manual	
F5: The Board found that while the job briefing and THA completed on the day of the accident met the requirements of WCC’s Safety Manual, Section 3, the job briefing entries on the THA under Hazard Control Measures were not performed by Crew 2 at worksite B447.	R5: The Board recommends that WCC Management implement a process to ensure all workers follow the documented hazards control measures on the THA, as written and signed.
F6: The Board found that THAs reviewed for the month of July had instances of incompleteness and lacked the rigor expected for the line work being performed.	R6: The Board recommends that WCC needs to establish and enforce expectations for conducting THAs in a thorough and professional manner.
F7: The Board found that CF2 conducted the job briefing as opposed to WCC Crew Foreman 1 (CF1), who was the Clearance Holder. This was contrary to established contract requirements that the Clearance Holder shall conduct the job briefing.	R7: The Board recommends that WCC Management implement a process to ensure that the Clearance Holder conducts the job briefing as per contract requirements.

Findings	Recommendations
Wilson Construction Company Safety Management Processes – Responsibility for Safety	
<p>F8: Based on the information presented, the Board found that the difference of opinion between CF2 and WCC Journeyman Lineman 1 (JL1) should have been elevated to the WCC Site Superintendent (SI) for resolution. Even though a follow-up discussion between CF2 and JL1 occurred, the discussion did not result in adequate grounding and bonding to establish an Equipotential Zone (EPZ) at Crew 2’s work location but did end with a determination to ground it differently.</p> <p>F9: The Board found that the SI left Geisel immediately after the job briefing. The Board determined if the SI had been involved with the follow-up discussion between CF2 and JL1 at Geisel, the EPZ differences of opinion should have been resolved.</p> <p>F10: The Board found that the WCC Quality Assurance/Quality Control/Safety Auditor (QA/QC) was not engaged in the work at the Geisel worksite and left the worksite prior to the discussion between CF2 and JL1. The Board determined if the QA/QC had been involved with the follow-up discussion between CF2 and JL1 at Geisel, the EPZ differences of opinion should have been resolved.</p> <p>F11: Based on the information presented, the Board found that there was no one person in charge of the worksite after the SI left the work location. Even though there was another crew foreman at the scene who was also the Clearance Holder, there was no clear delegation of authority. Having one clear person in charge could have resolved the EPZ differences between CF2 and JL1.</p>	<p>R8: The Board recommends that WCC management establish a clear delegation of authority at work locations when the SI is not physically present to make decisions.</p>

Findings	Recommendations
<p>F12: The Board found that the automated external defibrillator (AED) was not available at the accident scene immediately after the accident.</p>	<p>R9: The Board recommends that WCC management evaluate the need for additional AEDs or establish a protocol to make sure the device is on-site with the crews.</p>
<p>Wilson Construction Company Safety Management Processes – Site Specific Safety Plan</p>	
<p>F13: The Board found that Crew 2 did not install a ground between 46/5S and the driven ground rod, thus failing to establish an EPZ between all the conductive parts at their worksite.</p> <p>F14: The Board found that neither Crew 1 nor Crew 2 installed master grounds between either of their work locations (B447 or B461) and the Geisel Monument Tap section.</p>	<p>R10: The Board recommends that WCC management ensure all workers follow the documented grounding procedures outlined in WCC’s Safety Manual and the Site Specific Safety Plan (SSSP) posted on-site.</p> <p>R11: The Board recommends that WCC management establish and implement a formal training program on all grounding processes and procedures.</p>
<p>F15: The Board found that grounds on 46/5 were not applied under the direction of the Clearance Holder.</p>	<p>R12: The Board recommends that WCC management implement a process to ensure that the Clearance Holder directs the application of protective grounds as per the Contractor Clearance, Hold Order and Work Permit Procedure.</p>
<p>Jacobs Safety Management Responsibilities</p>	
<p>F16: The Board found that conflicts in the Terms and Conditions within the Master Contract and between the Master Contract and Contract Release 100 resulted in ambiguity for the Jacobs Quality Assurance Representative (QAR)’s roles and responsibilities for safety.</p>	<p>R13: The Board recommends that BPA’s Contracting Office reviews all contracts to remove contradictions in roles and responsibilities of the contractor.</p>
<p>Training</p>	
<p>F17: The Board was not provided sufficient evidence to determine if CF2 possessed all the necessary skills or knowledge to perform the work safely. However, with the limited evidence provided, the Board found that on the day of the accident, CF2 did not establish an EPZ.</p>	<p>R14: The Board recommends that WCC management establish and implement a formal training program which requires that workers demonstrate proficiency on all grounding processes and procedures.</p>
<p>Post Accident Modeling</p>	
<p>F18: Through engineering modeling and on-site testing, the difference of potential was sufficient to be hazardous; the Board determined that the creation of an EPZ at 46/5 would have mitigated the hazard.</p>	<p>R15: The Board recommends that WCC line crews continuously monitor step and touch voltages and establish and work within an EPZ.</p>

6. BOARD OF AUTHORITY LETTER

DOE F 1325.8e Electronic Form Approved by GILR - 09/26/2001
(8-89)

United States Government

Department of Energy
Bonneville Power Administration

memorandum

DATE: August 12, 2013
REPLY TO
ATTN OF: NF/WHSE-E
SUBJECT: Level I Accident Investigation Board

to: Claudia Andrews, Acting Chief Operating Officer K-7

This memorandum is to confirm the appointment of the individuals listed below to Bonneville Power Administration's Level I Accident Investigation Board. The purpose of the Board is to investigate a Wilson Construction Lineman fatality that occurred on July 30, 2013.

Adelmo Delacruz	Acting Senior Manager, Transmission Field Services Board Chairperson
Lynnial Trusty	Supervisory Contract Specialist, Internal Buisness Services. Board Member
Don Swanson	Transmission Line Maintenance Specialist, Transmission Engineering Services. Board Member
Brian Emery	Civil Engineer, Contract Management Office. Board Member
Dana Wolfe	Safety & Occupational Health Manager, Internal Business Services. Board Member
Bill McQuiston	Department of Energy Liason.

The incident shall be thoroughly investigated and a report prepared in a manner consistent with BPA's Manual Chapter 181. Bonneville's final report shall include the facts, analysis of facts and conclusions with findings and recommendations. The report shall be forwarded by memorandum to the Chief Safety Officer within 30 calendar days.

Brad Bea
Chief Safety Officer

cc:

C. Andrews – K-7
J. Hairston- N-4
L. Bekkedahl – T/Ditt2
R. Furrer – TF/Ditt2
J. Lahti- TE/Ditt2
D Freel – TED/TPP-2
T. Oleson – NS/DITT-2
J. Cramer – NF/PASCO
Official File – NF

6.1. Update to Board of Authority Letter

DOE F 1325.8a Electronic Form Approved by CILR – 09/26/2001
(6-89)

United States Government

Department of Energy
Bonneville Power Administration

memorandum

DATE: August 14, 2013

REPLY TO
ATTN OF: NF/WHSE-E

SUBJECT: UPDATED: Level I Accident Investigation Board

TO: Claudia Andrews, Acting Chief Operating Officer K-7

UPDATE: Replaces Board Member Lynnial Trusty with Tom Rhew

The remaining members for the Level I Accident Investigation Board remain unchanged to investigate a Wilson Construction Lineman fatality that occurred on July 30, 2013.

Adelmo Delacruz	Acting Senior Manager, Transmission Field Services Board Chairperson
Tom Rhew	Client Services Manager, Internal Buisness Services Board Member
Don Swanson	Transmission Line Maintenance Specialist, Transmission Engineering Services. Board Member
Brian Emery	Civil Engineer, Contract Management Office Board Member
Dana Wolfe	Safety & Occupational Health Manager, Internal Business Services. Board Member
Bill McQuiston	Department of Energy Liason.

The incident shall be thoroughly investigated and a report prepared in a manner consistent with BPA's Manual Chapter 181. Bonneville's final report shall include the facts, analysis of facts and conclusions with findings and recommendations. The report shall be forwarded by memorandum to the Chief Safety Officer within 30 calendar days.

Brad Bea
Chief Safety Officer

cc:
C. Andrews – K-7
J. Hairston- N-4
L. Bekkedahl – T/Ditt2
R. Furrer – TF/Ditt2
J. Lahti- TE/Ditt2
D Freel – TED/TPP-2
T. Oleson – NS/DITT-2
J. Cramer – NF/PASCO
Official File – NF

7. BOARD MEMBERS' SIGNATURES

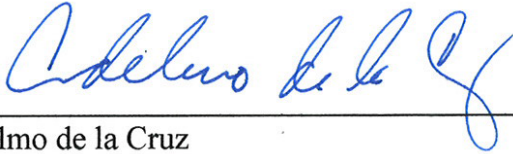

Adelmo de la Cruz
Board Chairperson
Bonneville Power Administration
Acting Senior O&M Manager, Transmission Field Services



Don Swanson
Board Member
Bonneville Power Administration
Transmission Line Maintenance Specialist
Transmission Engineering Services

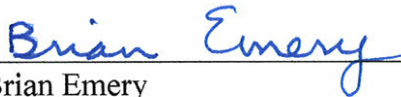

Brian Emery
Board Member
Bonneville Power Administration
Civil Engineer, Contract Management Services



Dana Wolfe
Board Member
Bonneville Power Administration
Safety and Occupational Health Manager
Internal Business Services



Thomas Rhew
Board Member
Bonneville Power Administration
Client Services, Internal Business Services

BOARD MEMBERS, ADVISORS AND CONSULTANTS

Board Members

Board Chairperson

Adelmo de la Cruz
Bonneville Power Administration
Acting Senior O&M Manager
Transmission Field Services

Board Member

Don Swanson
Bonneville Power Administration
Transmission Line Maintenance Specialist
Transmission Engineering Services

Board Member

Brian Emery
Bonneville Power Administration
Civil Engineer
Contract Management Services

Board Member

Dana Wolfe
Bonneville Power Administration
Safety & Occupational Health Manager
Internal Business Services

Board Member

Thomas Rhew
Bonneville Power Administration
Client Services
Internal Business Services

Advisors/Consultant

Advisor/Consultant:

William McQuiston, MAS Consultants

Administrative Coordinator

Consultant/Technical Editor

Susan Keffer, Project Enhancement Corporation

Appendix A. Barrier Analysis

Barrier analysis is based on the premise that hazards are associated with all tasks. A barrier is any means used to control, prevent, or impede a hazard from reaching a target, thereby reducing the severity of the resultant accident or adverse consequence. A hazard is the potential for an unwanted condition to result in an accident or other adverse consequence. A target is a person or object that a hazard may damage, injure, or fatally harm. Barrier analysis determines how a hazard overcomes the barriers, comes into contact with a target (e.g., from the barriers or controls not being in place, not being used properly, or failing), and leads to an accident or adverse consequence. The results of the barrier analysis are used to support the development of causal factors.

Table A-1: Barrier Analysis

Barrier Analysis Worksheet				
Hazard: Electrical Shock			Target: Crew Foreman 2	
	What Were the Barriers?	How Did Each Barrier Perform?	Why Did the Barrier Fail?	How Did the Barrier Affect the Accident?
B1	Proper grounding and bonding, creating an equipotential zone (EPZ).	The grounding method implemented by Crew 2 allowed an electrical potential difference to exist between the sectionalizing switch structure and the transmission lines which included the live parts of the B447 sectionalizing disconnect.	Crew 2 failed to connect the switch structure of B447 to the driven ground rod to create an EPZ.	Failure to ensure the sectionalizing switch structure and transmission line were at the same electrical potential resulted in an unrecognized difference of electrical potential sufficient to cause death.
B2	The isolated line section on the tap span was properly grounded as required by the Wilson Safety Manual and the Wilson Site Specific Safety Manual.	Not used.	Not used.	The tap section was part of the worksite and should have been included in the EPZ.

	What Were the Barriers?	How Did Each Barrier Perform?	Why Did the Barrier Fail?	How Did the Barrier Affect the Accident?
B3	“Step and touch” measurement.	Although performed on previous days, the “step and touch” measurement was not performed by Crew 2 on the day of the accident.	Not performed.	Crew 2 failed to perform the “step and touch” measurement and did not ensure that any hazardous electrical potential in the work area was identified and corrected.
B4	Task Hazard Analysis (THA)	The THA identified the need for establishing an EPZ and testing. (“Test with meter, install proper EPZ grounds.”)	Crew 2 did not perform the hazard control measures that were identified in the THA.	Failure to follow the hazard control measures in the THA resulted in failure to create an EPZ and was a lost opportunity for Crew 2 to identify and mitigate any hazardous electrical potential in the work area.
B5	WCC Safety Manual (Responsibilities for Safety)	JL1 exercised his employee safety responsibilities by discussing proper grounding and EPZ formation with CF2 in a discussion after the job briefing.	Difference of opinion was not elevated for resolution to the WCC Site Superintendent (SI).	Did not result in grounding and bonding to establish an EPZ.
B6		SI was not at the jobsite to resolve the difference of opinion.	SI left Geisel worksite location after the job briefing.	SI’s presence could have resolved the EPZ differences.

	What Were the Barriers?	How Did Each Barrier Perform?	Why Did the Barrier Fail?	How Did the Barrier Affect the Accident?
B7		WCC Quality Control/Quality Control/Safety Audit Manager (QA/QC) was on a conference call and not engaged in worksite observation; was not available to resolve the difference of opinion.	QA/QC was not engaged in the job briefing at Geisel and left the Geisel worksite prior to the discussion between CF2 and JL1.	QA/QC's presence could have resolved the EPZ differences.
B8	WCC Safety Manual, Section 11 – Grounding	Instructions in the WCC Safety Manual for grounding and EPZ were not followed.	Instructions in the WCC Safety Manual for grounding and establishing an EPZ were not followed.	Not following grounding procedures resulted in an unrecognized difference of electrical potential.
B9	WCC Site Specific Safety Plan (SSSP)	Instructions in the WCC SSSP for grounding and establishing an EPZ were not followed.	CF2 did not follow established WCC SSSP grounding and EPZ procedures.	Not following grounding procedures resulted in an unrecognized difference of electrical potential.

Appendix B. Change Analysis

Change is anything that disturbs the “balance” of a system from operating as planned. Change is often the source of deviations in system operations. Change can be planned, anticipated, and desired, or it can be unintentional and unwanted. Change analysis examines the planned or unplanned disturbances or deviations that caused the undesired results or outcomes related to the accident. This process analyzes the difference between what is normal (or “ideal”) and what actually occurred. The results of the change analysis are used to support the development of causal factors.

Table B-1: Change Analysis Worksheet

Change Analysis Worksheet				
	Accident Situation	Ideal, or Accident-Free Situation	Difference	Evaluation of Effect
C1	<p>Crew 2 did not follow the hazard control measures listed in the Task Hazard Analysis (THA).</p> <ul style="list-style-type: none"> • Identify, isolate, test and ground, test step and touch voltages. • Create an equipotential zone (EPZ). 	<p>Crew 2 would have followed the instructions in the THA to identify, isolate, test and ground, and test step and touch voltages. (Create an EPZ.) (Ideal)</p>	<p>Crew 2 did not follow the hazard control measures listed in the THA.</p>	<p>Improper grounding and failure to create an equipotential zone (EPZ) resulted in an unrecognized unidentified electrical potential to exist.</p>
C2	<p>The grounding system installed at 46/5 did not include a ground lead from the sectionalizing switch structure to the driven ground rod. An EPZ was not established.</p>	<p>The bonding system installed at 46/5 would have included a connection from the sectionalizing switch structure to the driven ground rod. (An EPZ was established.)</p>	<p>The bonding system at 46/5 did not include all structures/ components where work was being performed. 46/5 did not have an EPZ.</p>	<p>The bonding system installed at 46/5 did not ensure all structures/components were within an established EPZ. The possibility of uncontrolled and/or unrecognized electrical potential existed.</p>

	Accident Situation	Ideal, or Accident-Free Situation	Difference	Evaluation of Effect
C3	No master ground was included on the tap section of the line between structures 46/5 and 46/6.	A master ground would have been used on both sides of 46/5 and 46/6 and an EPZ was created at both sites.	46/5 had no EPZ and neither 46/5 nor 46/6 had master grounds on the tap section.	Improper grounding created a potential difference at the 46/5 worksite exposing Crew Foreman 2 (CF2) and others to hazardous energy.
C4	Step and touch voltage was not tested or monitored at 46/5 on the day of the accident.	Step and touch voltage would have been monitored continuously during the time the line was grounded. (Ideal)	Step and touch voltage was not tested or monitored on the day of the accident at 46/5.	Testing and monitoring step and touch voltage could have identified the high electrical potential which existed at the worksite at 46/5.
C5	Structure 46/5 had about 22+ miles of transmission line between the open breaker at Port Orford (B659) and the sectionalizing switch (B447).	Structure 46/6 had about 0.41 miles of transmission line between the open breaker at Rogue (B1861) and the sectionalizing switch (B461).	The transmission lines connected to 46/5 were significantly longer.	The lines coming into 46/5 may have provided higher probability of induction source.
C6	The switch relocation was due to design flaws (location).	The initial switch design was correct for location of the switches.	Design work not corrected prior to initial construction.	Incorrect initial switch design and installation resulted in WCC returning to perform corrective actions which resulted in increased risk.
C7	WCC was correcting workmanship (warranty) work.	Proper workmanship implies no warranty work required.	Defects in work required corrective actions.	Defects in work required corrective actions which resulted in increased work risk.

	Accident Situation	Ideal, or Accident-Free Situation	Difference	Evaluation of Effect
C8	<p>Crew 2 did not follow the Electrical Safety measures outlined in the SSSP testing/grounds/EPZ.</p> <p>Portable protective grounds.</p> <ul style="list-style-type: none"> • Did not properly ground from all sources of energy (Geisel Monument Tap). • All employees were not protected from hazardous inductive voltage by the installation of bonds to create an EPZ. 	<p>All crew members would have been familiar with the SSSP and followed the instructions. (Ideal)</p>	<p>Neither WCC crew installed a master ground on the isolated Tap section.</p> <p>Crew 2 did not install a bond from 46/5S to the driven ground rod to create an EPZ.</p>	<p>By not following the requirements of the SSSP for grounding, bonding and creation of an EPZ, an unrecognized electrical potential existed.</p>

	Accident Situation	Ideal, or Accident-Free Situation	Difference	Evaluation of Effect
C9	<p>Crew 2 did not follow the Electrical Safety measures outlined in the WCC Safety Manual for testing grounds and establishing an EPZ. Portable protective grounds.</p> <ul style="list-style-type: none"> • Did not properly ground from all sources of energy (Geisel Monument Tap). • All employees were not protected from hazardous inductive voltage from hazardous inductive voltage by the installation of bonds to create an EPZ. 	<p>All crew members are familiar with the WCC Safety Manual and followed the instructions. (Ideal)</p>	<p>Neither WCC crew installed a master ground on the isolated Tap section.</p> <p>Crew 2 did not install a bond from 46/5S to the driven ground rod to create an EPZ.</p>	<p>By not following the requirements of the WCC Safety Manual for grounding, bonding and creation of an EPZ, an unrecognized electrical potential existed.</p>
C10	<p>Site Superintendent (SI) was not at the Geisel location when the work was being performed.</p>	<p>SI was present to observe work activities and be available to resolve work practice differences and performance.</p>	<p>SI was not present at Geisel worksite.</p>	<p>Lost opportunity to observe work activities and be available to resolve work practice differences and performance.</p>
C11	<p>Automated external defibrillator (AED) was not present on the worksite.</p>	<p>AED was present at the worksite to assist with the rescue efforts. (Ideal)</p>	<p>No AED at the worksite.</p>	<p>Lost opportunity to provide advanced life saving technology to CF2 following electrical shock.</p>

Appendix C. Accident Chronology

An events and causal factors analysis was performed in accordance with the DOE Workbook, *Conducting Accident Investigations*. The events and causal factors analysis requires deductive reasoning to determine those events and/or conditions that contributed to the accident. Causal factors are the events or conditions that produced or contributed to the accident, and they consist of direct, contributing, and root causes. The direct cause is the immediate event(s) or condition(s) that caused the accident. The contributing causes are the events or conditions that, collectively with the other causes, increased the likelihood of the accident, but which did not solely cause the accident. Root causes are the events or conditions that, if corrected, would prevent recurrence of this and similar accidents. The causal factors are identified in Table D-1: Events and Causal Factors Chart.

Table C-1: Accident Chronology

Barrier/ Change	Date/Time	Event	Condition(s)
	12/21/2010	Contract Release for rebuilding the Bandon-Rogue line issued to Wilson Construction Company (WCC).	
	04/25/2011	Pre-construction meeting for the rebuild of Bandon-Rogue line held.	
C6	05/09/2011	Notice to Proceed (NTP) on Bandon Line rebuild release.	Bonneville Power Administration (BPA) provided drawings for initial installation showed incorrect switch location offsets from center line.
	11/3-9/2011	Independent WCC safety audit.	Audit was an independent assessment of WCC's safety program implementation in the field. Audit performed by Electrical Safety Consultants International. Audit performed on three of WCC's projects including the Bandon-Rogue No. 1 115kV rebuild.
	01/2012	Bandon-Rogue line rebuild work completed.	

Barrier/ Change	Date/Time	Event	Condition(s)
	03/06/2012	WCC forwarded their safety audit to BPA.	
	04/25/2012	Switch drawing review completed indicating design errors.	
C7	08/10/2012	Warranty letter issued to WCC.	BPA recommended work be completed in two phases due to limitations caused by weather and long lead times for replacement material.
	09/10/2012	WCC correction plan (Part 1) submitted to BPA.	
	09/24/2012	WCC warranty work (Part 1) NTP.	
	10/26/2012	WCC warranty work (Part 1) work complete.	
	06/21/2013	The Release for corrective switch work issued to WCC.	
	07/1/2013	Pre-construction meeting held.	Attended by Construction Manager (CM), BPA Contracting Officer (CO2), Jacobs Resident Engineer (RE) and Wilson Quality Assurance/Quality Control/Safety Audit Manager (QA/QC). The Site Superintendent (SI) was listed as Clearance Holder and general foreman.
	07/01/2013	Contracting Officer 2 (CO2) sent WCC SSSP to BPA Safety Office.	
	07/01/2013	BPA Safety Office reviewed SSSP.	
	07/02/2013	SSSP returned to CO2 with comments.	
	07/03/2013	Final review of SSSP by Safety Office.	Required installation of EPZ. (no change) CF1 and JL1 listed as Clearance Holders in WCC SSSP.

Barrier/ Change	Date/Time	Event	Condition(s)
	07/03/2013	NTP for corrective switch work on Bandon-Rogue issued to WCC.	Warranty work on Bandon-Rogue disconnect switches at the same time. Release span of work – 07/08/2013 – 09/13/2013. BPA drawings relocate switches to seven foot offset.
	07/29/2013 1031	Terminal Clearance.	North Bend Operator accepted a Terminal Clearance from Coos-Curry on switch 3002 at Geisel Monument Substation.
	07/29/2013 1040	Terminal Clearance.	North Bend Operator reports the Terminal Clearance to MCC Dispatcher, and the Dispatcher accepts the terminal clearance.
	07/29/2013 1651	Switch B659 at Port Orford opened and tagged.	
	07/29/2013 1721	Switch B1861 at Rogue substation opened and tagged.	Ground switch 7497 closed at Rogue substation.
	07/29/2012 1854	WCC Crew Foreman 1 (CF1) picks up Clearance from MCC Dispatcher.	Work Clearance No. M3749W for Port Orford-Rogue section including the Geisel Monument Tap. Ground switch at Geisel Monument open. Ground switch at Rogue terminal closed. Ground switch at 46/5 open.
	07/30/2013 0730	General tailboard meeting held at the WCC material yard on Cape Blanco Road.	General morning meeting. Meeting lasted approximately 15 minutes. QA/QC attended tailboard meeting.
	07/30/2013 ~0745	Jacobs Quality Assurance Representative (QAR2) left the Cape Blanco Road. material yard.	

Barrier/ Change	Date/Time	Event	Condition(s)
	07/30/2013 ~0745	CF1 and WCC Crew Foreman 2 (CF2) discussed bonding and grounding following general morning meeting.	
B7	07/30/2013 ~0800	QA/QC arrived at Geisel site.	
	07/30/2013 0800	Crews arrive at Geisel site.	
B4	07/30/2013 0815-0830	The job briefing and Task Hazard Analysis (THA) discussed at Geisel included everyone except QA/QC.	CF2 led THA. The THA included discussion of possible induction, establishment of an Equipotential Zone (EPZ) at each site, proper rigging, lifting, and Personal Protective Equipment.
	07/30/2013	CM left Geisel site after job briefing was concluded.	CM left to get gas in his vehicle.
B6 C10	07/30/2013 0830	SI left Geisel enroute to Cape Blanco to unload a truck.	Automated external defibrillator (AED) in SI's truck, not available at the accident site.
	07/30/2013 ~0830	Equipment Operator 2 (EO2) began to clear crane landing site after job briefing.	
B5	07/30/2013 ~0830	CF2 and Journeyman Lineman 1 (JL1) have discussion about EPZ.	EO2 witnessed CF2 and JL1 having a discussion.

		Crew 1 Switch 46/5S		Crew 2 Switch 46/6S		
Barrier/Change	Date/Time	Event	Condition(s)	Barrier/Change	Event	Condition(s)
B2 C3, C5 C8, C9	07/30/2013 ~0900	Crew 1 tested, grounded and bonded creating an EPZ at switch B461.	Step and touch measured 0.54V. Step and touch not recorded on THA.			
	07/30/2013 ~0915	Crew 1 started switch disassembly.	After the job briefing, Jacobs Quality Assurance Representative 2 (QAR2) observed Crew 1 start to remove horizontal jumpers.	B1, B2 B3, B8 B9 C1, C2 C3, C4 C5, C8 C9	CF2 and JL2 grounded line for work on B447.	Ground rod driven into dirt ~20 inches. Three-phase master grounds to ground rod. No step and touch recorded in accordance with the THA. No EPZ existed. Not bonded like switch B461 as discussed in THA.
	07/30/2013 ~0930				JL2 removed sectionalizing jumper.	
	07/30/2013 ~0930				CF2 climbed switch structure to attach lift slings.	
	07/30/2013 ~0930				EO2 lowered rigging down on B-Phase of B447.	

		Crew 1 Switch 46/5S		Crew 2 Switch 46/6S		
Barrier/Change	Date/Time	Event	Condition(s)	Barrier/Change	Event	Condition(s)
	07/30/2013 ~0930				Rigging attached.	
	07/30/2013 ~0935				EO2 began unbolting structure from footing legs.	
	07/30/2013 ~0935	After spending time observing Crew 1, QAR2 went to watch Crew 2.			QAR2 spoke with CF2 about specifications.	
	07/30/2013 ~0945			B1, B2 B8, B9 C1, C8 C9	CF2 positioned and belted to insulator stack to assist with B-Phase jumper removal.	
	07/30/2013 ~0945				CF2 made contact with a difference of potential across the blade end insulator stack of B447.	
	07/30/2013 ~0945	Electrical Shock				

Date/Time	Event	Condition(s)
07/30/2013 ~0945	JL2 heard CF2 yell.	
07/30/2013 ~0945	EO2 looked up and saw an arc between CF2's leg and switch structure.	

Date/Time	Event	Condition(s)
07/30/2013 ~0945	CF1 heard JL2 yell and told EO1 to call 911.	
07/30/2013 ~0945	JL1 heard JL2 yell and assisted EO1 with the 911 call.	
07/30/2013 ~0946	CF1 ran to CF2's location to assist.	
07/30/2013 ~0946	CF1 climbed switch structure to perform rescue.	
07/30/2013 ~0946-0950	JL2 positioned bucket truck with jib crane next to CF2.	
07/30/2013 ~0946-0950	EO2 cleared area for ambulance and potential helicopter landing.	
07/30/2013 ~0946-0950	QAR2 ran to CF2's location and began documenting accident scene.	
07/30/2013 ~0946-1000	CF1 performed rescue breaths and chest compression on CF2 in structure 46/5S.	
07/30/2013 ~1000 - 1005	CF1 and JL2 rigged and lowered CF2 to the ground with jib crane.	
07/30/2013 ~0946-1000	JL1 positioned CF2 on the ground and began CPR.	
07/30/2013 ~0946-1000	CF1 and JL2 assisted in CPR until EMS personnel arrived on the scene.	
07/30/2013 1005	EMS personnel arrived on-site.	

Date/Time	Event	Condition(s)
07/30/2013 ~1000-1010	EMTs applied AED and shocked CF2.	
07/30/2013 1010	EMTs loaded CF2 into ambulance and transported to Curry General Hospital.	
07/30/2013 1051	CF2 pronounced dead at the hospital.	
07/30/2013 1056	Curry County Sheriff on scene notified of death.	
07/30/2013 1056	Sheriff and QAR2 notified the crew that CF2 had passed away.	

Appendix D. Events and Causal Factor Chart

An events and causal factors analysis was performed in accordance with the DOE workbook *Conducting Accident Investigations*. The events and causal factors analysis requires deductive reasoning to determine those events and/or conditions that contributed to the accident. Causal factors are the events or conditions that produced or contributed to the accident, and they consist of direct, contributing, and root causes. The direct cause is the immediate event(s) or condition(s) that caused the accident. The contributing causes are the events or conditions that, collectively with the other causes, increased the likelihood of the accident, but which did not solely cause the accident. Root causes are the events or conditions that, if corrected, would prevent recurrence of this and similar accidents. The causal factors are identified in Table D-1: Events and Causal Factors Analysis Chart.

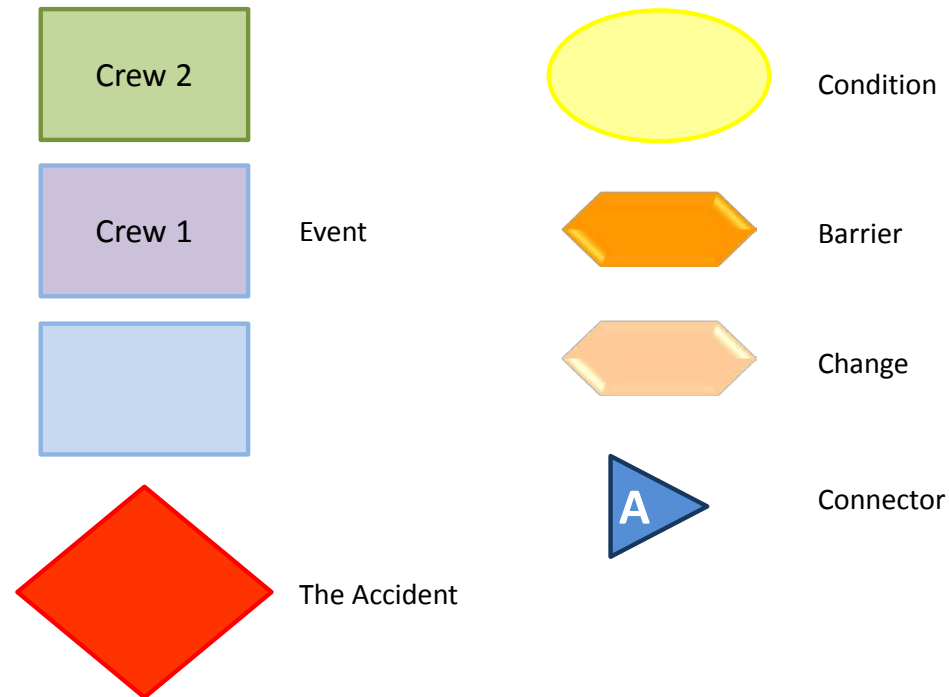
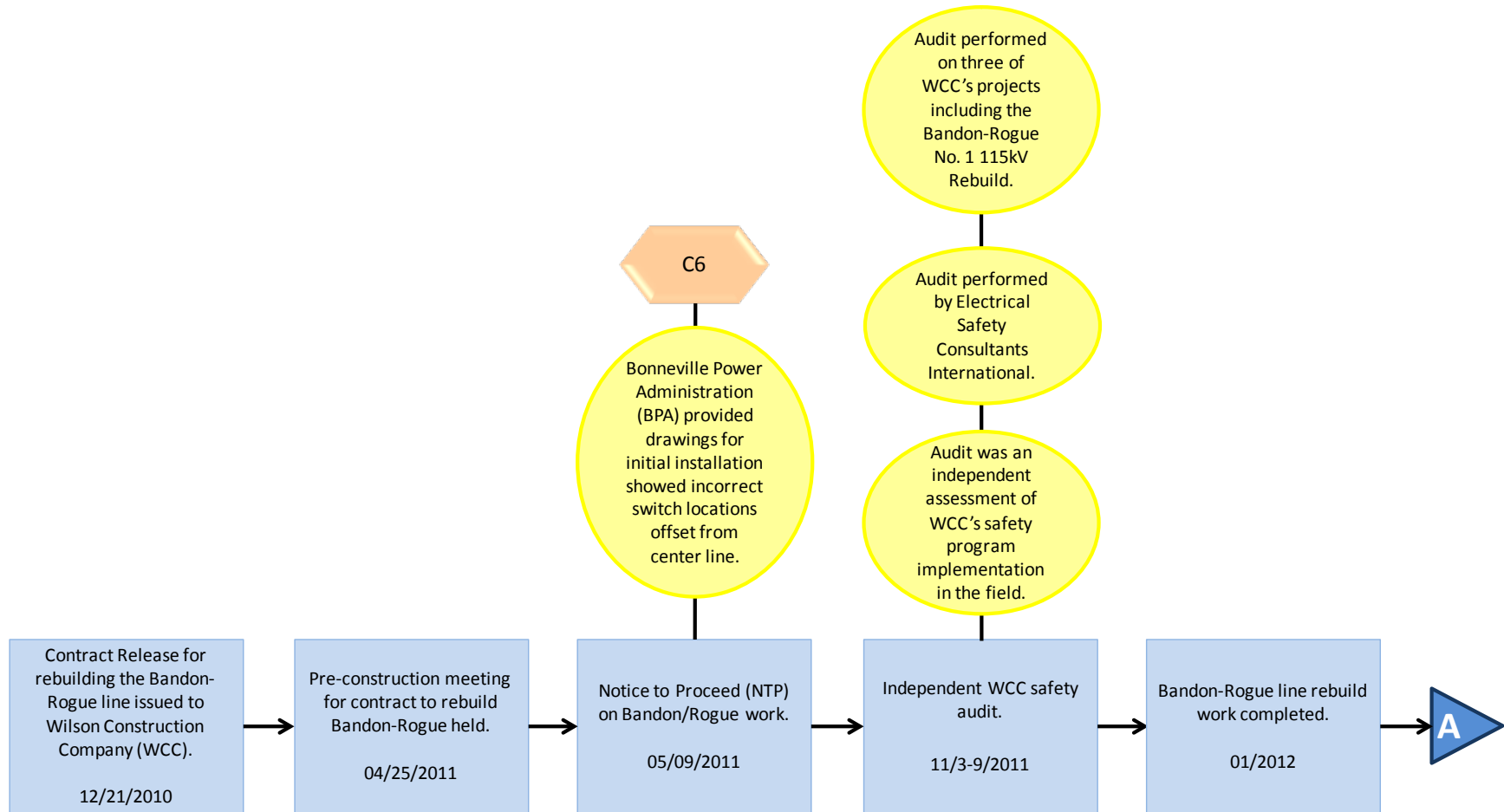
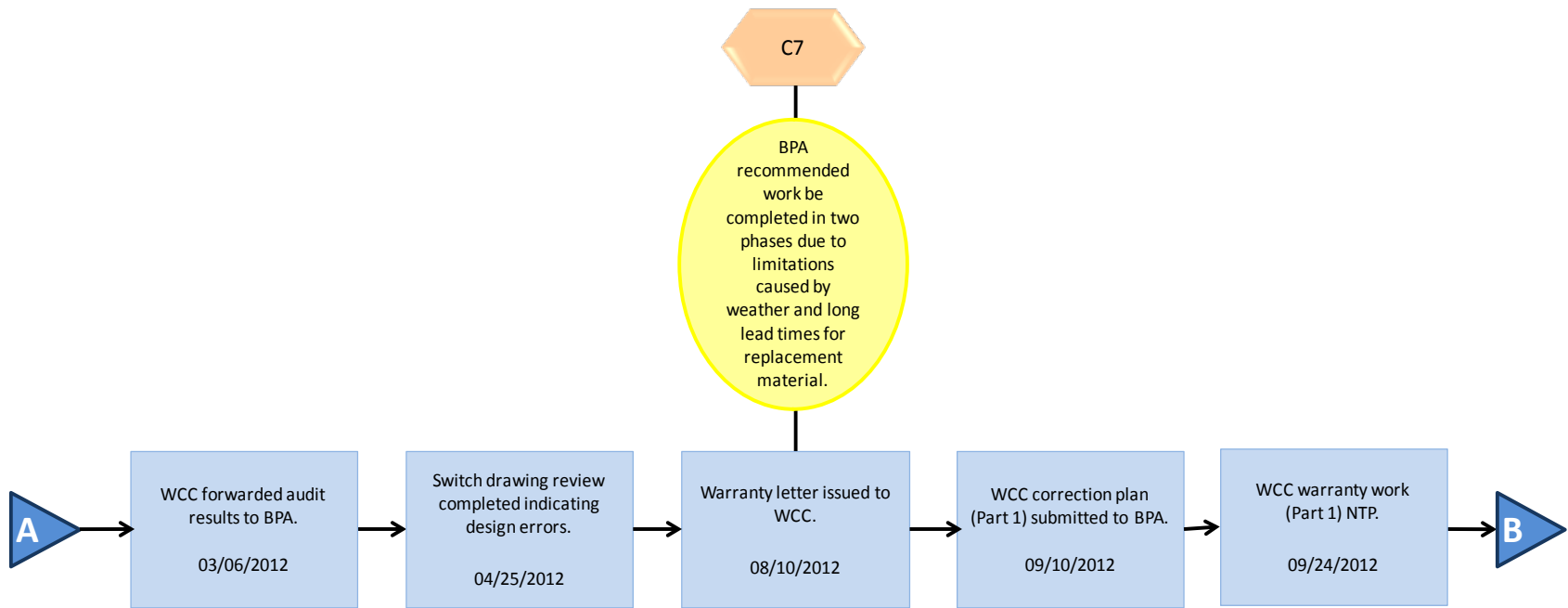
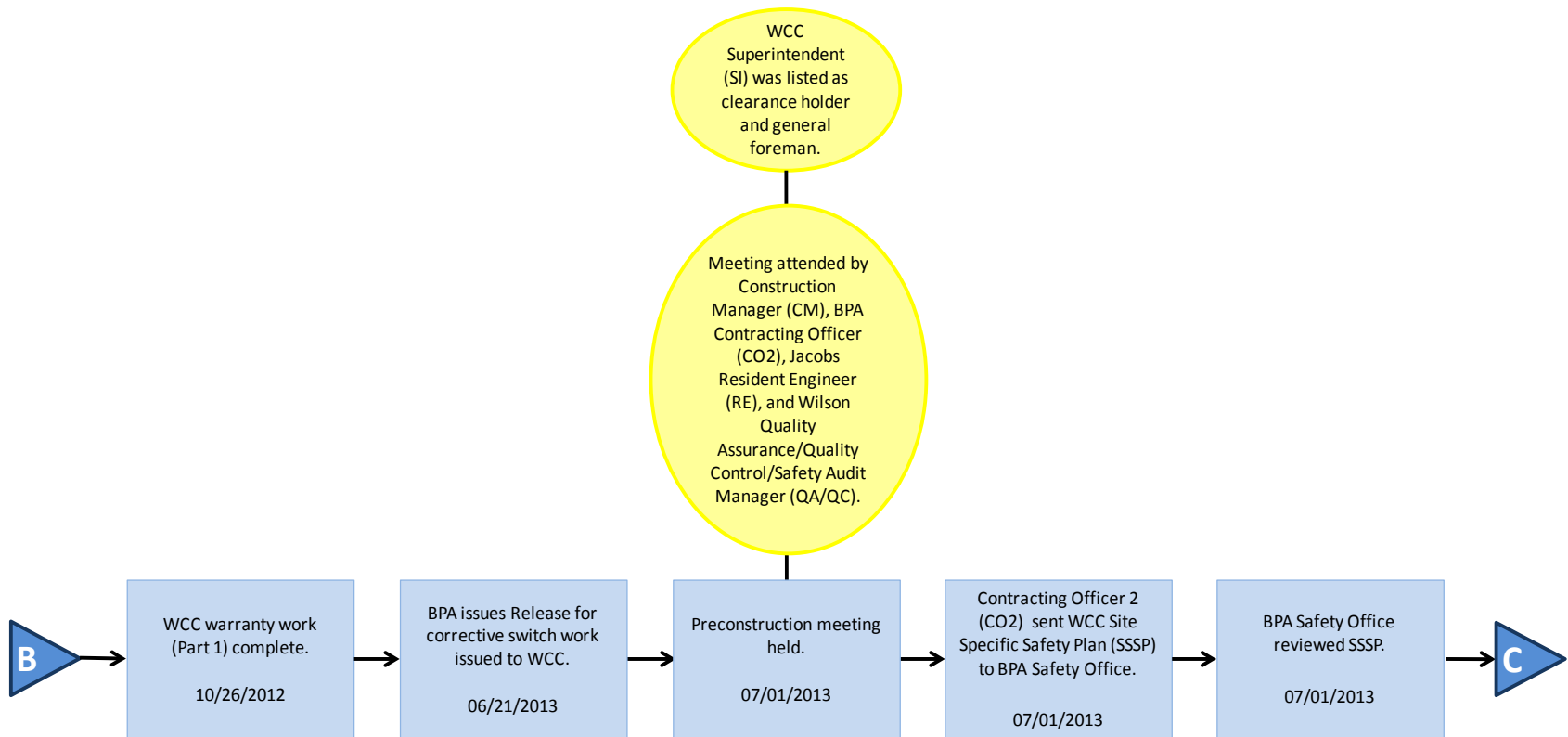
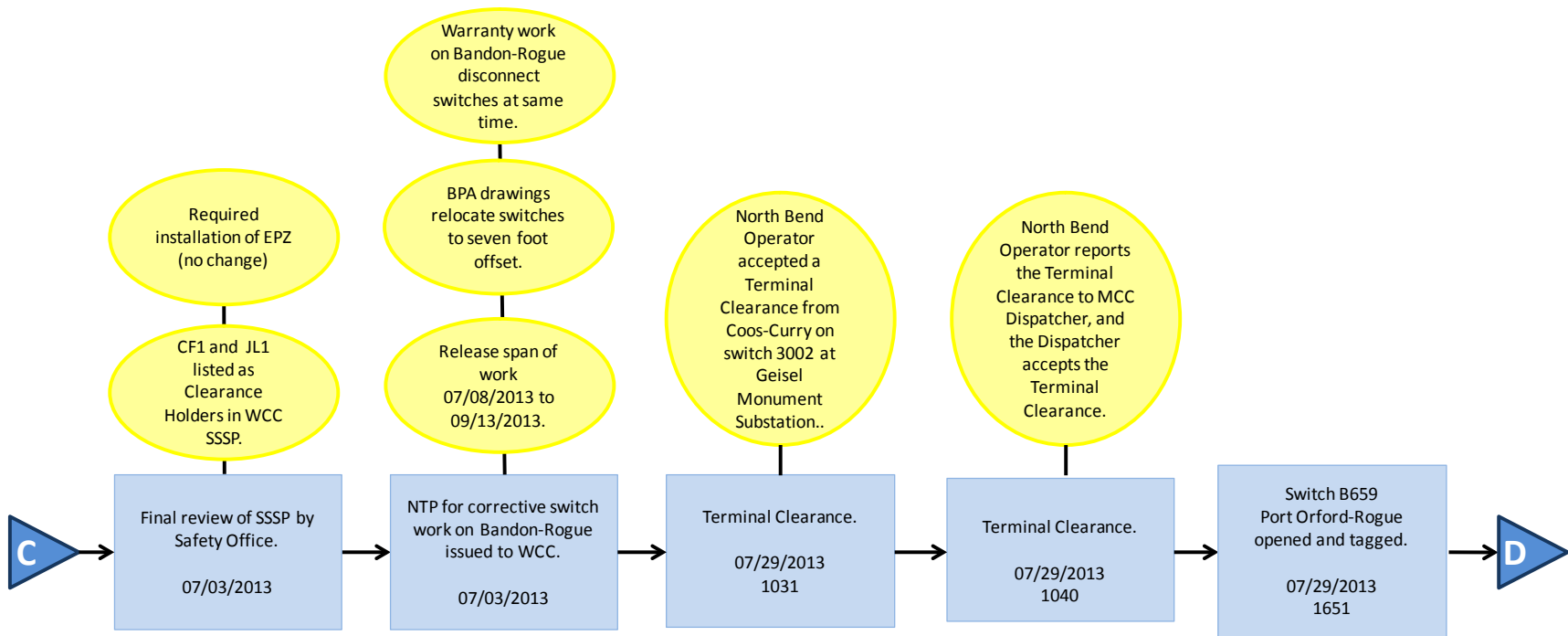

Table D-1: Events and Causal Factors Chart









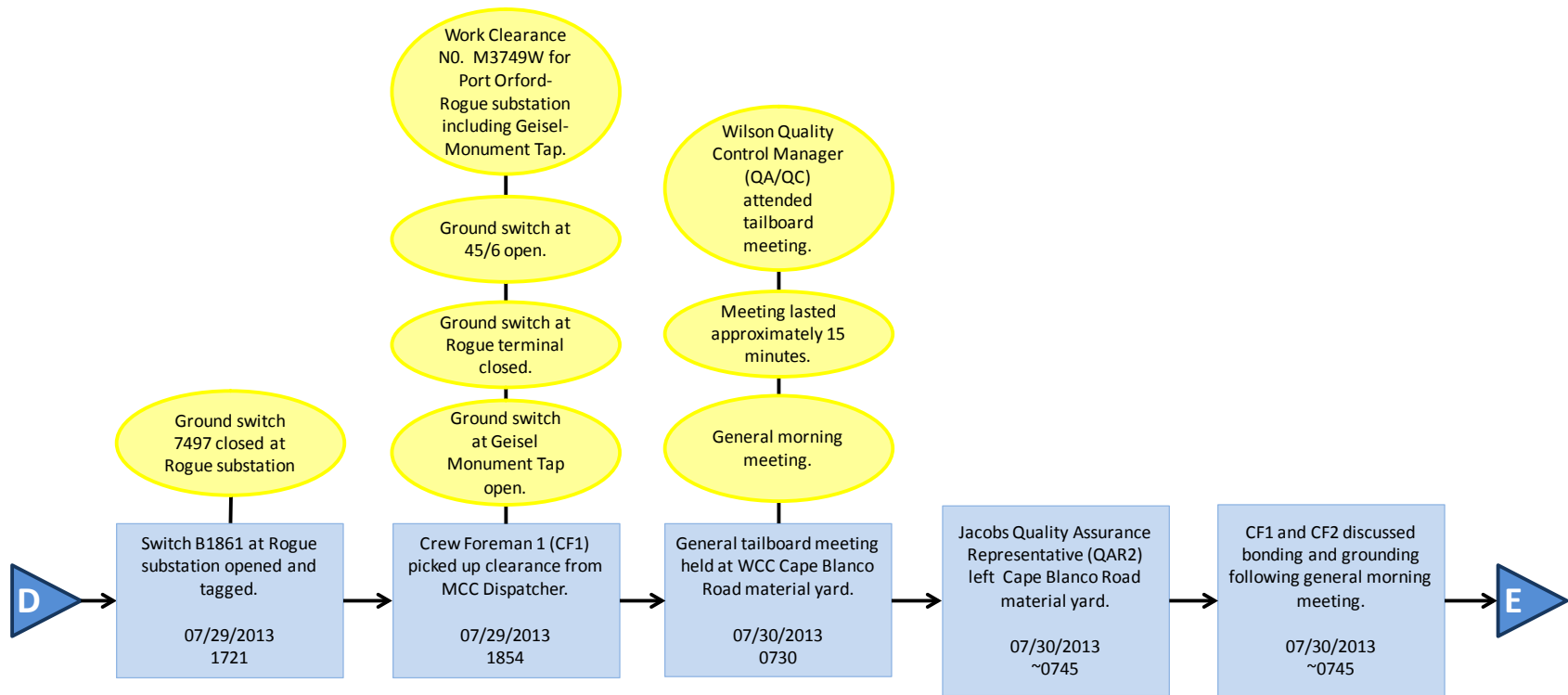

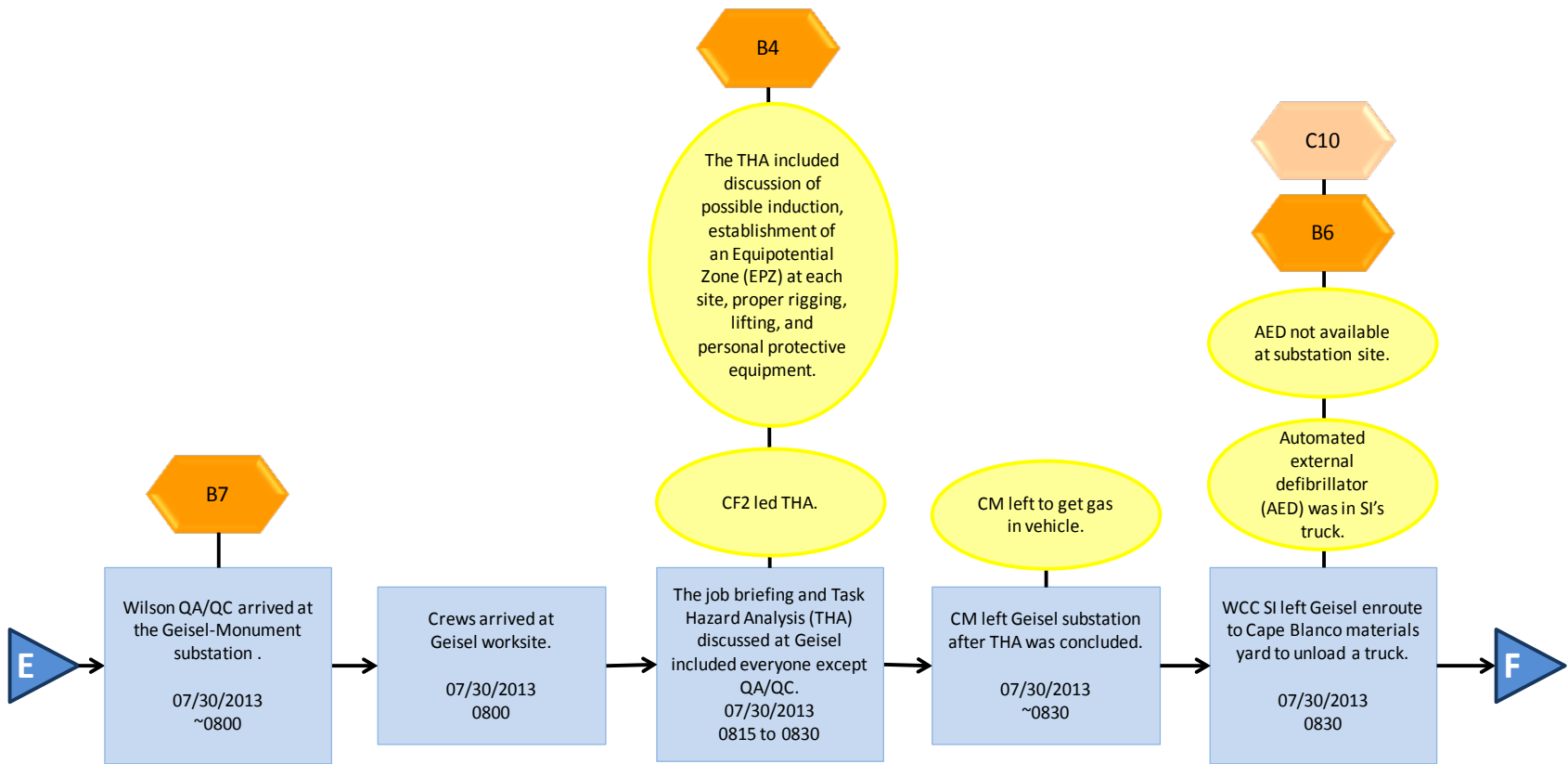

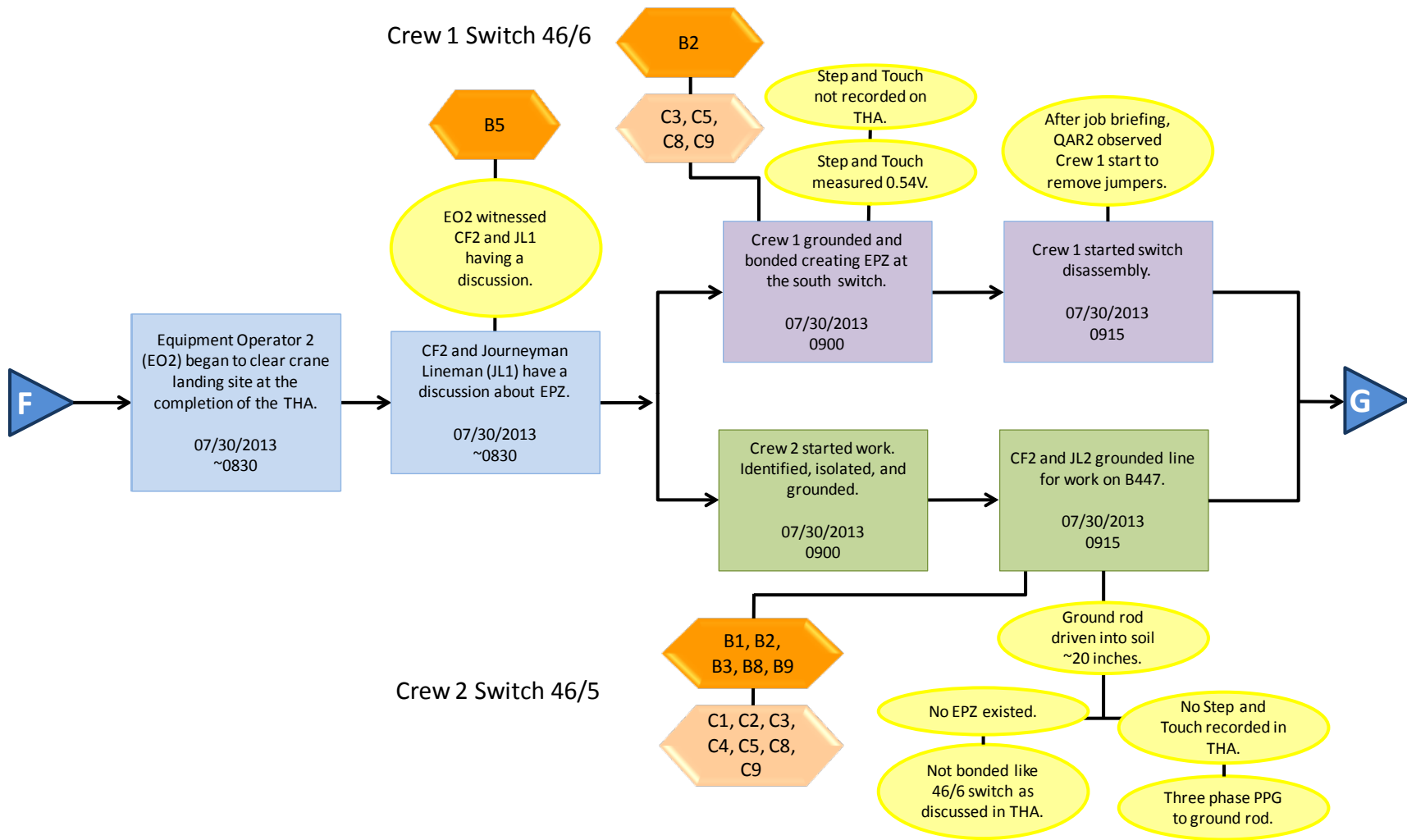

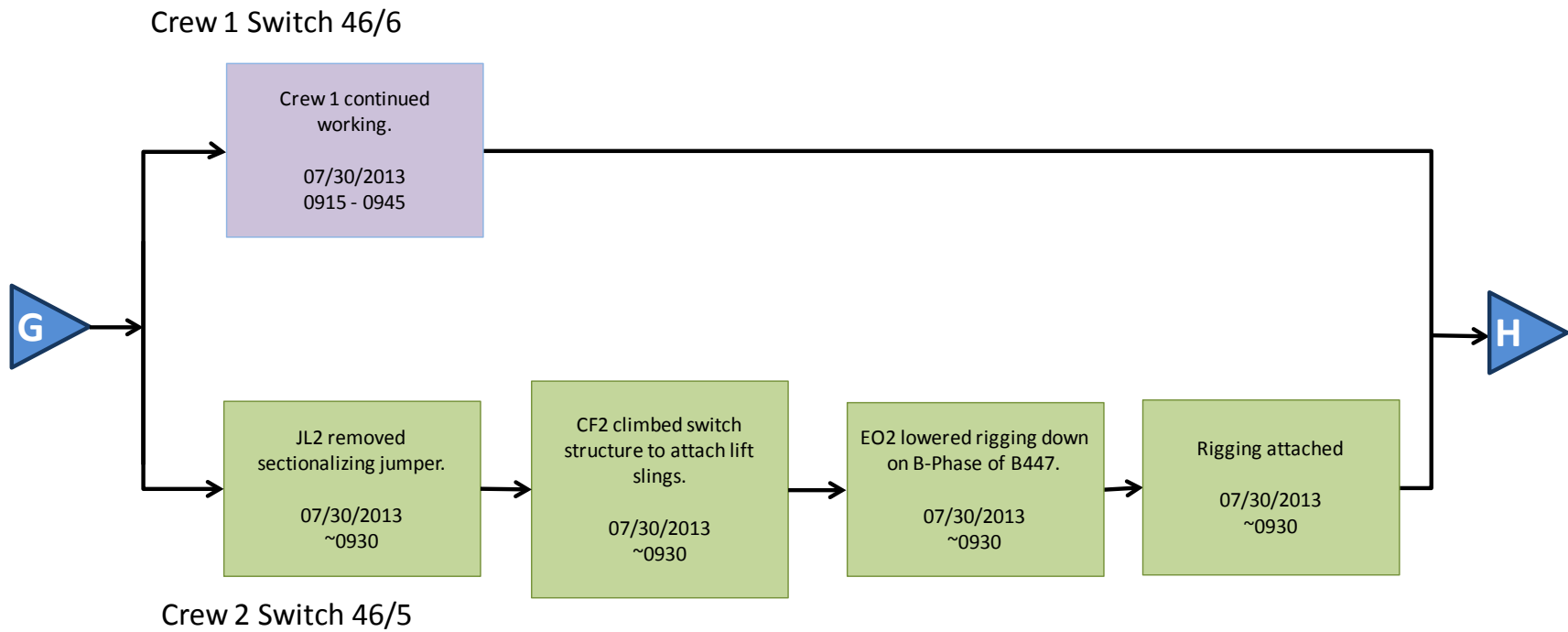

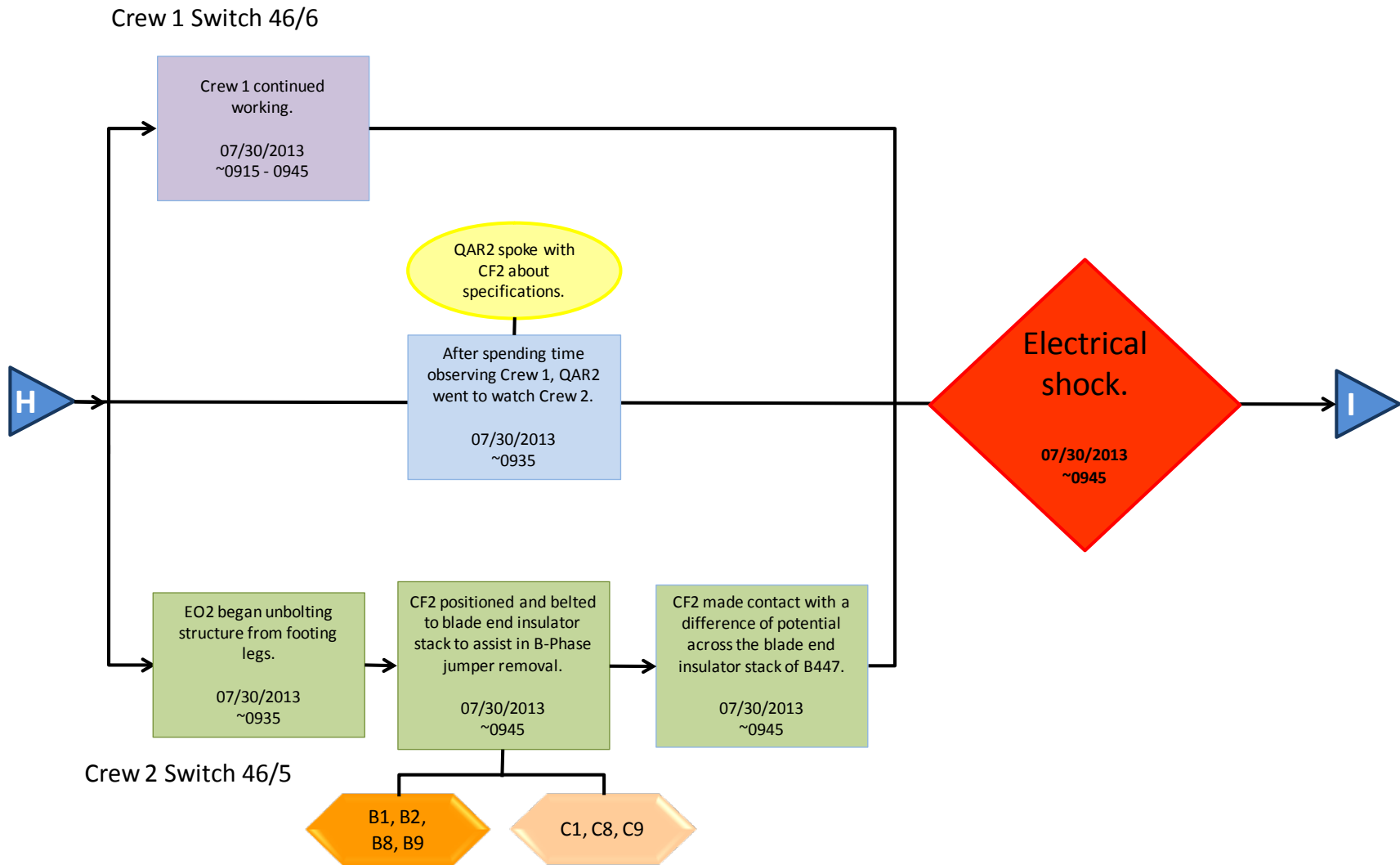

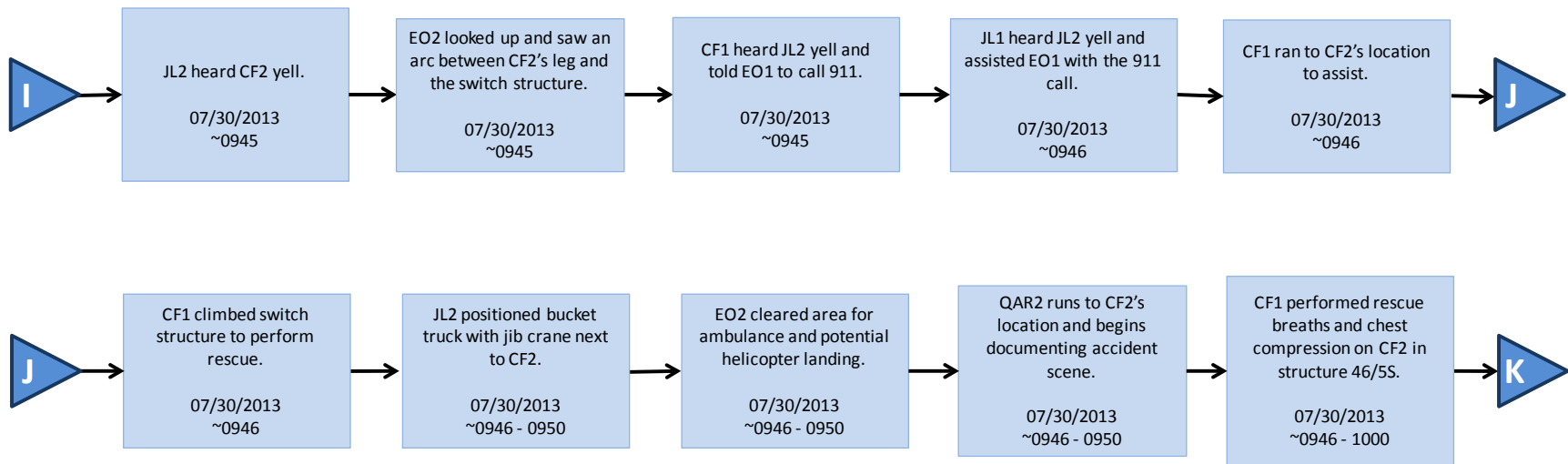

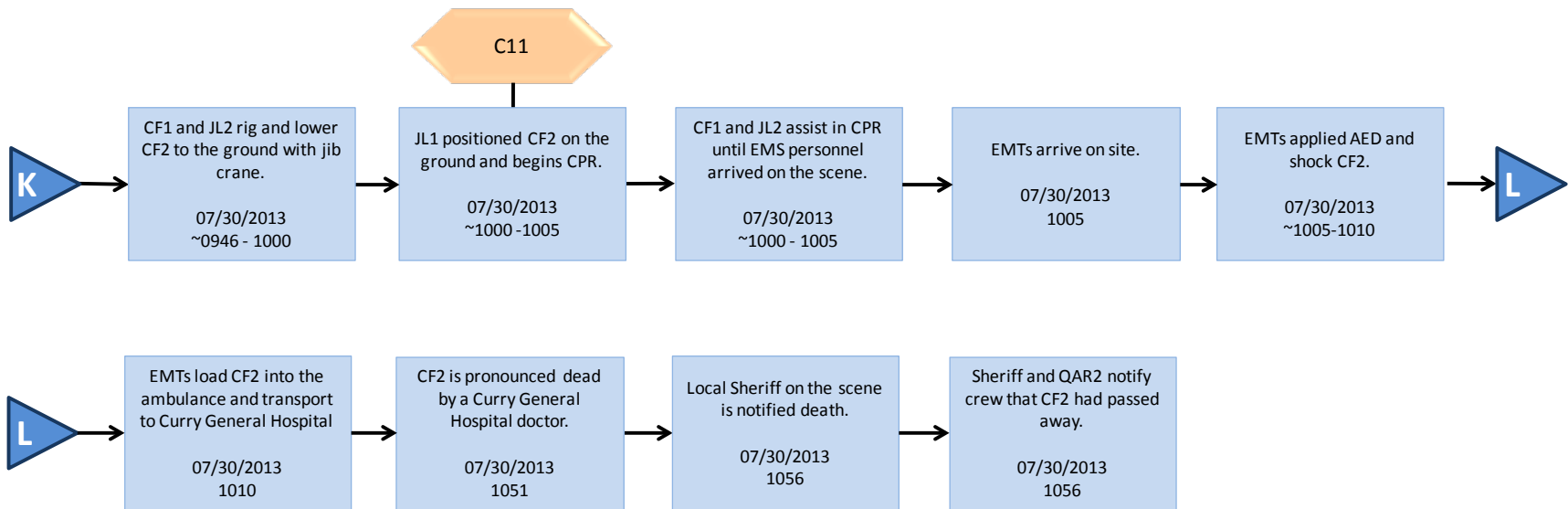

Appendix E. Glossary

Equipotential zone. An equipotential zone is a work zone in which the worker is protected from electric shock from differences in electric potential between objects in the work area. These differences in potential can be caused by induced voltage, line re-energization, or lightning. The worker in an equipotential zone is protected from electric shock because there is a near identical state of electrical potential between any two points on the body.

https://www.osha.gov/SLTC/etools/electric_power/hazardous_energy_control_equipotential.html

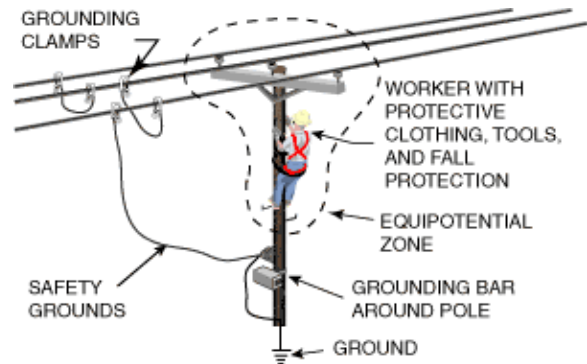

Step and touch potential. Awareness of step and touch potential, caused by ground potential rise, is important for anyone working on high-voltage power transmission systems. In a typical step and touch application, the transmission line is de-energized and is bonded to the tower to be safe to work on. However, the transmission line itself acts as a very large antenna, and can pick up large amounts of energy which must be shunted to earth ground. And if the tower ground is faulty, the ground potential may rise and a dangerous condition can result.

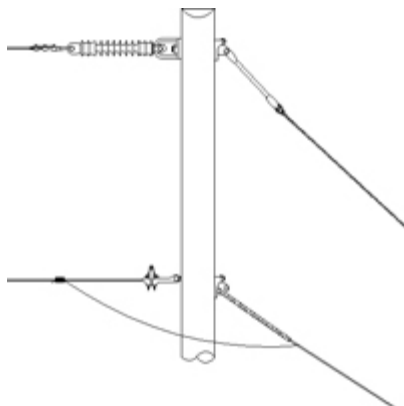
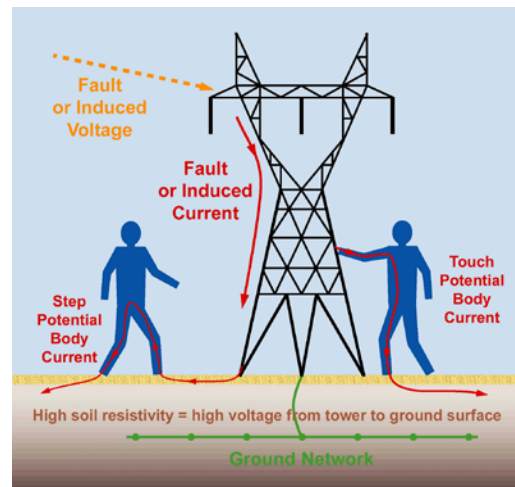

Down guys are non-energized wire restraints used to provide additional support to power poles. Down guys are typically used for poles with overhead lines that make turns, terminate or go underground via risers. In neighborhoods, they are characterized as the wires that come down from the pole into the ground at an angle, with a protective plastic shielding.

Hot stick. In the electric power distribution industry, a **hot stick** is an insulated pole, usually made of fiberglass, used by electric utility workers when engaged on live-line working on

energized high-voltage electric power lines, to protect them from electric shock. Depending on the tool attached to the end of the hot stick, it is possible to test for voltage, tighten nuts and bolts, apply tie wires (twisted lengths of ductile wire which fasten the running cable to its supporting insulators), open and close switches, replace fuses, lay insulating sleeves on wires, and perform various other tasks while not exposing the crew to a large risk of electric shock.

Appendix F. Accident Investigation Terminology

Table F-1: Accident Investigation Terminology

Accident Investigation Terminology
<p>A causal factor is an event or condition in the accident sequence that contributes to the unwanted result. There are three types of causal factors: direct cause(s), root cause, and the contributing causal factors.</p> <p>The direct cause of an accident is the immediate events or conditions that caused the accident. Typically, the direct cause of the accident may be constructed or derived from the immediate, proximate event and conditions next to or close by to the accident on the Events and Causal Factors Chart.</p> <p>Root causes are the causal factors that, if corrected, would prevent recurrence of the same or similar accidents. Root causes may be derived from or encompass several contributing causes. They are higher-order, fundamental causal factors that address classes of deficiencies, rather than single problems or faults.</p> <p>Contributing causes are events or conditions that collectively with other causes increased the likelihood of an accident but that individually did not cause the accident. Contributing causes may be longstanding conditions or a series of prior events that, alone, were not sufficient to cause the accident, but were necessary for it to occur. Contributing causes are the events and conditions that “set the stage” for the event and, if allowed to persist or re-occur, increase the probability of future events or accidents.</p> <p>Event and causal factors analysis includes charting, which depicts the logical sequence of events and conditions (causal factors that allowed the accident to occur), and the use of deductive reasoning to determine the events or conditions that contributed to the accident.</p> <p>Barrier analysis reviews the hazards, the targets (people or objects) of the hazards, and the controls or barriers that management systems put in place to separate the hazards from the targets. Barriers may be physical or administrative.</p> <p>Change analysis is a systematic approach that examines planned or unplanned changes in a system that caused the undesirable results related to the accident.</p>

