



# TRANSITIONING THE TRANSPORTATION SECTOR:

Exploring the Intersection of Hydrogen  
Fuel Cell and Natural Gas Vehicles

September 9, 2014



Sandia National Laboratories

# **TRANSITIONING THE TRANSPORTATION SECTOR:**

Exploring the Intersection of Hydrogen  
Fuel Cell and Natural Gas Vehicles

**September 9, 2014**

American Gas Association  
400 N. Capitol St., NW,  
Washington, DC 20001

**Organized in partnership by:**

Sandia National Laboratories,  
AGA and Toyota, in support of the  
U.S. Department of Energy

## Organizing Committee

Dawn Manley, Sandia National Laboratories  
Kathryn Clay, American Gas Association  
Fred Joseck, Department of Energy Fuel Cell Technologies Office  
Craig Scott, Toyota Motor Sales  
Jacob Ward, Department of Energy Vehicle Technologies Office  
Todd West, Sandia National Laboratories

## Participants

Glen Andersen, National Conference of State Legislatures  
Don Anton, Savannah River National Laboratory  
Jim Bruce, UPS  
Gerry Conway, Plug Power  
Bill Craven, Mercedes-Benz  
Greg Dierkers, National Governors Association  
Catherine Dunwoody, California Air Resources Board  
Matt Forman, Chrysler  
Joseph Guzzo, GM  
Will James, Department of Energy  
Siddiq Khan, American Council for an Energy-Efficient Economy  
Jim Kliesch, Honda  
Christine Kretz, Air Products and Chemicals  
Michael Levy, Aaqius  
Lynn Lyon, Pioneer Natural Resources  
Bill MacLeod, Hyundai  
Morry Markowitz, Fuel Cell and Hydrogen Energy Association  
Matt McClory, Toyota  
Chris McGill, American Gas Association  
Mike McGowan, Linde  
Marc Melaina, National Renewable Energy Laboratory  
Richard Meyer, American Gas Association  
John Mizroch, Council on Competitiveness  
Rick Murphy, American Gas Association  
Mark Musculus, Sandia National Laboratories  
Joan Ogden, UC Davis  
Jim Pisz, Toyota Motor Sales  
Prabhu Rao, Nuvera  
Jeff Reed, Southern California Gas Company

Reuben Sarkar, Department of Energy  
Sunita Satyapal, Department of Energy  
Mark Smith, Department of Energy  
Ned Stetson, Department of Energy  
Benn Tannenbaum, Sandia National Laboratories  
Mike Veenstra, Ford  
Todd Wetzel, GE  
Bob Wimmer, Toyota  
Frank Wolak, Fuel Cell Energy

## Workshop Assistance

Cover Design and Publication – Daniel Strong  
Administrative – Melissa Tallion and Sue Swann

## Prepared by

Dawn Manley  
Sandia National Laboratories  
7011 East Avenue  
Mail Stop 9054  
Livermore, CA 94550  
(925) 294-4589  
dmanley@sandia.gov

*We gratefully acknowledge the support of the U.S. Department of Energy Fuel Cell Technologies and Vehicle Technologies Offices, Toyota, and the American Gas Association in helping underwrite this workshop*

## Contents

<b>EXECUTIVE SUMMARY</b> .....	1
<b>BACKGROUND</b> .....	3
<b>OBSERVATIONS</b> .....	4
<b>FOR WHAT MARKETS ARE NATURAL GAS AND HYDROGEN IN DIRECT COMPETITION, AND HOW MIGHT THEY BE BETTER SUITED FOR DIFFERENT TRANSPORTATION APPLICATIONS?</b> .....	8
<b>HOW DO WE GET FUELING STATIONS BUILT? ARE THERE BUSINESS MODELS THAT CAN SIMULTANEOUSLY SUPPORT HYDROGEN AND NATURAL GAS?</b> .....	11
<b>WHAT CAN WE LEARN FROM PROGRAMS AND POLICIES THAT HAVE BEEN IMPLEMENTED AT THE STATE LEVEL?</b> .....	14
<b>FURTHER CHALLENGES AND OPPORTUNITIES</b> .....	16
<b>APPENDIX 1: AGENDA</b> .....	18
<b>APPENDIX 2: PRIMER</b> .....	20



# Transitioning the Transportation Sector: Exploring the Intersection of Hydrogen Fuel Cell and Natural Gas Vehicles

## EXECUTIVE SUMMARY

On September 9, 2014, Sandia National Laboratories, American Gas Association, and Toyota, in support of the U.S. Department of Energy's Fuel Cell Technologies and Vehicle Technologies Offices, convened stakeholders across the hydrogen and natural gas communities to consider opportunities and challenges at the intersection of their development as alternative transportation fuels. Although natural gas and hydrogen have an obvious intersection – natural gas is the feedstock for 95% of the hydrogen produced in the U.S. – little attention has been given to how these fuels can evolve in the context of each other. This workshop explored infrastructure requirements, regional trends, and market opportunities at the intersection of hydrogen fuel cell and natural gas use for on road transportation. The goal of the workshop was to provide background and context for thinking through the dynamic evolution of these two transportation options in tandem, and to identify opportunities that can support the synergistic development of both fuels.

The Transitioning the Transportation Sector workshop was organized around three key questions:

- For what **markets** are natural gas and hydrogen in direct competition? How might they complement each other and be better suited for different transportation applications?
- How do we get fueling **stations** built? Are there business models that can simultaneously support hydrogen and natural gas?
- What can we learn from programs and policies that have been implemented at the **state** level?

Key observations from the workshop are summarized below:

**Markets for hydrogen and natural gas will naturally segment.** Vehicle selection for commercial applications, such as freight trucks and delivery vans, are driven by economics and business needs. These businesses are already on a path towards broad use of natural gas for trucks and vans. In contrast, automakers expect that fuel cell electric vehicles (FCEVs) will be adopted more broadly for personal transportation. While there may be overlap in selected niches, such as buses or light duty fleet vehicles, the current market and manufacturer signals indicate that hydrogen and natural gas will likely segment to different application areas.

**Starting from common standards and equipment may enable synergistic development of both hydrogen and natural gas.** Infrastructure, storage, and delivery have been cited as common challenges in the deployment of both natural gas and hydrogen fuels. Although both are compressed gaseous fuels, current trends indicate that requirements for hydrogen and compressed natural gas are likely to be tailored to optimize each individually rather than focusing on what is common. While different pressure and materials requirements have been developed independently for each fuel, utilizing common equipment, pressures, and manufacturing processes could enable economies of scale for storage equipment and handling that could simultaneously drive down costs and advance both alternatives.

**Co-location of hydrogen and natural gas fueling stations would create new business opportunities.** Natural gas and hydrogen fueling stations are currently being developed independently. Having both fuels at the same station could improve operational expenditures and also take advantage of common supply chains. Coupling these infrastructure economics with common equipment manufacturing for both vehicle and fuel supply technologies has the potential to create new business models that lowers the cost and reduces the risk of both alternatives in tandem.

**Roles of fuel providers and utilities will shift.** The increasing diversity and potential higher margins of alternative fuels will add new players to the fuel supply market. The infrastructure needed for natural gas, hydrogen, and electricity as transportation fuels has brought a diversity of industry stakeholders into the marketplace. Looking forward, new business models may bring together utilities, industrial gas companies, and customer service providers, and thus create new partnerships that alter the customer fueling experience and change the factors that contribute to station profitability. Moreover, models for multi-fuel generation – such as the simultaneous production of natural gas, hydrogen, and electricity – can shift the paradigm from traditional centralized production and distribution.

**Thorough system requirements and cost assessments are needed to quantify the benefit of co-development of natural gas and hydrogen.** A number of technical and policy barriers will affect the broader deployment of alternative fuels and infrastructure. While the relatively low cost and abundant supply of natural gas has stimulated deployment, uncertainty in fuel costs, vehicle incentives, and technology investments continue to limit hydrogen vehicles and infrastructure. Systematic assessments that elucidate the sensitivities and relative significance of the barriers would help inform a path forward for the development of both natural gas and hydrogen, as well as the potential benefits for multi-fuel stations and common designs for storage and compression technologies. Exploring the economics of scale of common designs, manufacturing, and distribution can quantify the impact of co-development and inform a more efficient roadmap for their development.



**The near term may not grow up to look like the long term.** While natural gas has often been described as a bridge to hydrogen, the growth of alternative fuels and vehicles will continue to be unpredictable. Development of alternative fuels is unlikely to follow a linear path in which each station serves as a component of an optimized, long term infrastructure. Accept that the multiple generations of vehicle and fueling infrastructure technologies will coexist, and that the corresponding infrastructure will be built and rebuilt over time.



**Sometimes you know that the chicken came first.** Deployment of new fuels and vehicles are often posed as a chicken-or-egg conundrum. However, aggressive deployment programs for natural gas vehicles and fueling infrastructure have indicated that getting enough natural gas vehicles on the road can create the market conditions for the development of complementary, unsubsidized fueling infrastructure. In contrast, FCEV advances by automakers have been stimulated by zero emission vehicle mandates. Corresponding government investment in early infrastructure build out is expected to lead to self-sustained markets. While not yet definitive, different government investments – vehicle incentives for natural gas and station infrastructure incentives for hydrogen – are expected to stimulate these two alternatives.

## BACKGROUND

While hydrogen and natural gas are among the technology options that have the potential to transform the transportation sector over the next several decades, much of the investment and efforts to date have targeted the development of a single option independent of the other. On September 9, 2014, Sandia National Laboratories, American Gas Association, and Toyota, in support of the U.S. Department of Energy's Fuel Cell Technologies and Vehicle Technologies Offices, convened stakeholders across the hydrogen and natural gas communities to consider opportunities and challenges at the intersection of their development as alternative transportation fuels. While there are many venues and organizations that focus on technology, policy, or business drivers for either natural gas or hydrogen, few opportunities exist to examine the interdependencies and intersection of these technologies. Through this workshop, the organizers convened a diverse set of stakeholders across the natural gas and hydrogen communities to address opportunities for synergism and identify where competition may influence their development. Participants spanned the auto industry, freight delivery fleets, gas suppliers, gas storage developers, utilities, academics, gas and hydrogen industry associations, national laboratories, and federal and state government stakeholders. The workshop explored infrastructure requirements, regional trends, and market opportunities at the intersection of hydrogen fuel cell and natural gas use for on road transportation. The goal of the workshop was to provide background and context for thinking through the dynamic evolution of these two transportation options in tandem, and to identify opportunities that can support the synergistic development of both fuels.

The *Transitioning the Transportation Sector* workshop was organized around three key questions:

- For what **markets** are natural gas and hydrogen in direct competition? How might they complement each other and be better suited for different transportation applications?
- How do we get fueling **stations** built? Are there business models that can simultaneously support hydrogen and natural gas?
- What can we learn from programs and policies that have been implemented at the **state** level?

Key observations that emerged from the dialogue follow. While these themes do not indicate consensus among all participants, many participants either contributed to these themes or identified that these findings could frame future development of the co-evolution of natural gas and hydrogen. The balance of the report provides additional detail and supporting information organized according to the discussions focused on the three questions.

## OBSERVATIONS

### Markets for hydrogen and natural gas will naturally segment

Vehicle selection for commercial applications, such as freight trucks and delivery vans, are driven by economics and business needs. Routine usage profiles, fleet size, and infrastructure availability or development costs shape the economics of technology selection. Moreover, introduction of alternative fueled vehicles has historically been enabled by subsidies, and the recent low cost of natural gas fuels in the U.S. and relative attainability of natural gas vehicles for fleet applications has created favorable market conditions for investment in compressed natural gas (CNG) and liquefied natural gas (LNG) vehicles. Government subsidies or grants have enabled businesses to invest in these vehicles and also to build the necessary supporting fueling infrastructure. While fleet owners have expressed interest in FCEVs or other alternative vehicles, relatively few of these other powertrains have been adopted to date due to the lack of model availability. Several major automakers have either released or have announced plans to release FCEVs in select markets. The auto industry is expecting that consumers interested in early technology adoption, zero tailpipe emissions, or the quiet drive and handling of the electric drive in a FCEV will move the light duty market toward FCEVs. While there may be overlap in selected niches, such as buses or light duty fleet vehicles, the current market and manufacturer signals indicate that hydrogen and natural gas will likely segment to different application areas.

### Starting from common standards and equipment may enable synergistic development of both hydrogen and natural gas

Infrastructure, storage, and delivery have been cited as common challenges in the deployment of both natural gas and hydrogen fuels. Although both are compressed gaseous fuels, current trends indicate that requirements for hydrogen and CNG are likely to be tailored to optimize each individually rather than focusing on what is common. For example, hydrogen embrittlement of standard metals has driven hydrogen station storage technologies to costly stainless steel tanks needed for rapid refueling and high-pressure dispensing. Compressed gas at 5,000 psi or 10,000 psi has emerged as the technology path for on-board storage, with carbon-fiber reinforced composite storage tanks used to balance strength, weight, and sufficient vehicle range in FCEVs. In contrast, fueling infrastructure for CNG has diverged to include both time-fill (multi-hour) or fast-fill stations. Fast-fill of CNG utilizes a series of storage tanks at 4,300 psi. In addition, compressed natural gas vehicles typically use lower cost steel tanks at 3,600 psi. While these different pressures and materials have been developed independently for each fuel, utilizing common equipment, pressures, and manufacturing processes could enable economies of scale for storage equipment and handling that could simultaneously drive down costs and advance both alternatives.



Hydrogen and natural gas share a number of common entry to market barriers. Image from DOE EERE Fuel Cell Technologies Office. [http://energy.gov/sites/prod/files/2014/09/f18/fcto\\_2014\\_h2\\_ng\\_wkshp\\_joseck.pdf](http://energy.gov/sites/prod/files/2014/09/f18/fcto_2014_h2_ng_wkshp_joseck.pdf).

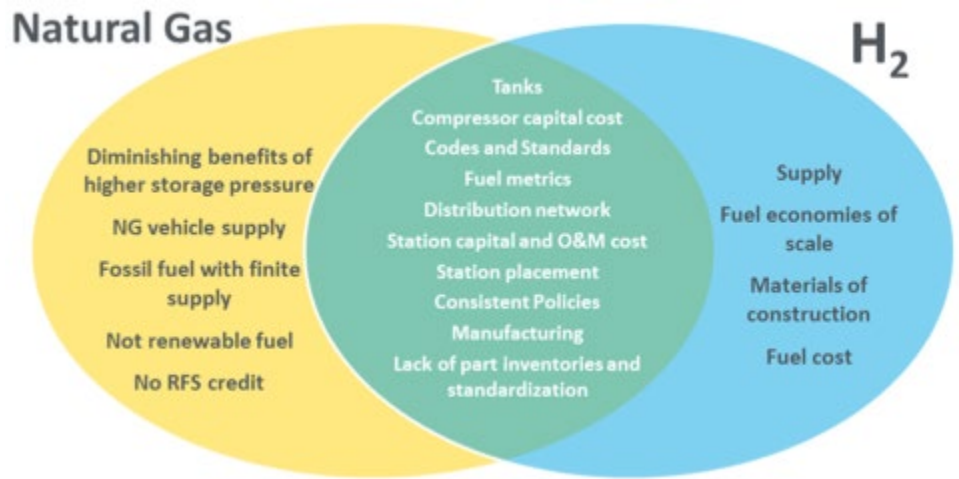

### Co-location of hydrogen and natural gas fueling stations would create new business opportunities

Stakeholders in fuel infrastructure development have typically focused on building either natural gas or hydrogen fueling stations rather than developing both simultaneously. In particular, industrial gas companies are often faced with a choice between promoting and investing in a hydrogen or in a natural gas station – a direct competition between these alternatives. However, having both fuels at the same station could improve operational expenditures and also take advantage of common supply chains. Coupling these infrastructure economics with common manufacturing of equipment for both vehicle and fuel supply storage technologies has the potential to create new business models that support both alternatives in tandem. Planning for this in advance rather than positioning a hydrogen station across the street from a natural gas station can considerably cut costs.

Co-location of multiple fuels may also reduce risk by creating multiple revenue streams. While margins on diesel and gasoline are less than five percent, conventional fuel stations typically rely upon a co-located convenience store to increase station profitability. CNG is a relatively high margin fuel, with approximately 35% of the cost of CNG being the cost of natural gas feedstock relative to 80% of the cost of gasoline attributed to petroleum cost. Even with the additional costs of processing and distribution, CNG is a relatively high margin fuel. While current estimates for hydrogen feedstock vary from \$4-\$12 to produce a gallon of gasoline equivalent fuel, lower feedstock costs over time may also enable hydrogen to emerge as a high margin fuel. The co-location of multiple fuels with high margins would likely lead to new business models for fueling infrastructure development.

### Roles of fuel providers and utilities will shift

While the petroleum industry has historically been the sole supplier of conventional fuels, the increasing diversity and potential higher margins of alternative fuels will

add new players to the fuel supply market. The infrastructure needed for natural gas, hydrogen, and electricity as transportation fuels has brought a diversity of industry stakeholders into the marketplace. For example, the Clean Fuels Outlet Program mandated that clean, alternative fuel stations in California would be provided once a certain number of vehicles using that fuel were certified to the Low Emission Vehicles Standard.<sup>1</sup> This led to utilities building CNG stations, yet utilities had little experience or guidance in siting, deploying, and operating stations. They established modest set rates of return, backstopped by rate payers, which brought them into the business of providing transportation fuels. Moreover, they invested in CNG vehicles for their fleets so that their fleets became a predictable customer for the fuel.

Looking forward, new business models may bring together utilities, industrial gas companies, and customer service providers, and thus create new partnerships that alter the customer fueling experience and change the factors that contribute to station profitability. As an example, while consumers have become accustomed to a rapid fueling experience with little variation from gasoline station to station, new models may lead to a differentiated suite of services beyond the typical convenience stores at conventional fueling stations. Moreover, models for multi-fuel generation – such as the simultaneous production of natural gas, hydrogen, and electricity, with hydrogen stored for later on-demand dispensing – can shift the paradigm from traditional centralized production and distribution.

**Thorough system requirements and cost assessments are needed to quantify the benefit of co-development of natural gas and hydrogen**

A number of technical and policy barriers will affect the broader deployment of alternative fuels and infrastructure. While the relatively low cost and abundant supply of natural gas has stimulated deployment, uncertainty in fuel costs, vehicle incentives, and technology investments continue to limit hydrogen vehicles and infrastructure. Systematic assessments that elucidate the sensitivities and relative significance of the barriers would help inform a path forward for the development of both natural gas and hydrogen, as well as the potential benefits for multi-fuel stations and common designs for storage and compression technologies. Exploring the economics of scale of common designs, manufacturing, and distribution can quantify the impact of co-development and inform a more efficient roadmap for their development.

**The near term may not grow up to look like the long term**

While natural gas has often been described as a bridge to hydrogen, the growth of alternative fuels and vehicles has been and will continue to be unpredictable. Initial volumes will be small and localized, and depend on local populations, policy drivers, and commodity prices. Development of alternative fuels is unlikely to follow a linear path in which each station serves as a component of an optimized, long term

1. [http://www.arb.ca.gov/msprog/clean\\_cars/lacc%20summary-final.pdf](http://www.arb.ca.gov/msprog/clean_cars/lacc%20summary-final.pdf)



infrastructure. However, while the five year solution is unlikely to look like the 30 year solution, the early station development provides valuable lessons that shape the longer term solutions. For example, hydrogen and natural gas may develop in stages analogous to battery technology advances: cadmium batteries were followed by nickel metal hydrides, which have since been overtaken by lithium ion batteries in many applications. Research continues to focus on developing higher capacity battery chemistries. Each battery technology had an economic driver that built the infrastructure for its manufacture and incorporation into consumer electronics and vehicles, and each of these technologies continues to be used for different target applications. Learnings from each generation helped shape the next, yet new manufacturing capabilities had to be built for each technological advance. Similarly, alternative vehicles and fueling infrastructure will become more sophisticated over time. Multiple generations of technologies will coexist, and the corresponding infrastructure will be built and rebuilt over time.

### Sometimes you know that the chicken came first

Deployment of new fuels and vehicles are often posed as a chicken-or-egg conundrum. Case studies of California and Texas are showing how the development of hydrogen and natural gas for transportation, respectively, can address this challenge. Texas set a goal to ensure that there were enough natural gas vehicles and refueling stations to support goods movement across three major cities – Dallas, Houston, and San Antonio. Their original goal was to have 8 stations and 550 heavy trucks to connect this “Texas Triangle,” and the Texas Commission on Environmental Quality provided grants to offset the cost of infrastructure and vehicles, initially dedicated 80% to vehicles and 20% to infrastructure.<sup>2</sup> These goals were quickly surpassed, leading to over 100 natural gas stations as of September 2014.<sup>3</sup> While initial program participants were larger companies, participation expanded into small businesses and single station owner operators in subsequent rounds. Once a sufficient number of natural gas trucks were on the road, demand and margins became high enough for fueling stations to become profitable without subsidies. Moreover, since the natural gas stations were required to be publicly accessible, small businesses could invest in natural gas vehicles knowing that the fuels were readily available. For Texas, stimulating sufficient demand created the market conditions for infrastructure development.

California’s Zero Emission Vehicle (ZEV) mandate has encouraged several major auto manufacturers to introduce FCEVs into the marketplace. While FCEVs have just become available to consumers in select Southern California markets, expanded offerings have been announced for 2015 and 2016. The California Fuel Cell Partnership is projecting vehicles to grow from the hundreds currently on road to 6,500 by 2017, and 18,000 by 2020.<sup>4</sup>

2. Texas Commission on Environmental Quality. <http://www.tceq.texas.gov/airquality/terp>.

3. Railroad Commission of Texas, 9/8/14. <http://www.rrc.state.tx.us/about-us/commissioners/porter/news/090814b/>.

4. California Fuel Cell Partnership, July 2014. “A California Road Map. The Commercialization of Hydrogen Fuel Cell Vehicles 2014 Update: Hydrogen Progress, Priorities and Opportunities (HyPPO) Report.”



Joan Ogden (UC Davis), Jim Bruce (UPS), and Jim Kliesch (Honda) provided perspectives on the factors that influence the natural gas and fuel cell electric vehicle markets. As panel discussants, they stimulated a conversation on the economic and environmental factors that would influence the market demands for these alternative technologies.

In parallel, the state has committed \$92M to support a network of 51 hydrogen stations by 2016. As part of this expansion, they are beginning to see common station designs rather than one-of-a-kind stations, indicating increasing sophistication in infrastructure development. The combination of ZEV credits and infrastructure investments are intended to simultaneously support the chickens and eggs to critical masses that ultimately become self-sustained by the market rather than by subsidies.

### FOR WHAT MARKETS ARE NATURAL GAS AND HYDROGEN IN DIRECT COMPETITION, AND HOW MIGHT THEY BE BETTER SUITED FOR DIFFERENT TRANSPORTATION APPLICATIONS?

For the light duty market, many of the major auto manufacturers expect that compressed natural gas vehicles make sense for fleets with centralized refueling and possibly for long distance consumers. Under these conditions, the lower cost of fuel relative to diesel or gasoline would offset the higher initial vehicle purchase cost. However, there are relatively few factory-built dedicated natural gas vehicles currently available to consumers in the U.S.: the Honda Civic Natural Gas is the only passenger car, with the Chevy Silverado 2500, Dodge Ram 2500, and Ford F-250 available as CNG pickup trucks, and the Chevy Express, GMC Savana, and Ford Transit Connect available as CNG vans.<sup>5</sup> Automakers note that higher purchase price, limited fueling infrastructure, and the additional onboard space needed for CNG vehicles limit their appeal in the U.S. market. The Honda Civic CNG has a current cost premium of \$4,000 over the comparable gasoline version, and the

5. DOE Alternative Fuels Data Center. [http://www.afdc.energy.gov/vehicles/natural\\_gas\\_availability.html](http://www.afdc.energy.gov/vehicles/natural_gas_availability.html).



Chevrolet Impala bi-fuel sedan, the only other CNG passenger car that has been announced for model year 2015, has a premium of about \$8,000.<sup>6</sup>

Emissions are another factor that limits the appeal of light duty natural gas vehicles. While emissions estimates for CNG vehicles vary and are the subject of ongoing refinement, the official U.S. government source for fuel economy information notes that natural gas vehicles produce 20–45% less smog-producing pollutants and 5–9% less greenhouse gas emissions<sup>7</sup> based on GREET Model estimates for dedicated and bi-fuel CNG vehicles relative to reformulated gasoline vehicles.<sup>8</sup> Environmentalists note that longer term solutions require electrification and the potential for carbon neutral fuels. Moreover, regulations for fuel efficiency and emissions of conventional fueled vehicles are become increasingly strict and changing the baseline for comparison. These limitations are reflected in recent alternative vehicle sales: through the first half of 2014, IHS Automotive reported 254 new CNG vehicle registrations, whereas electric vehicles and plug-in hybrid registrations are reported at 47,000 and 46,000, respectively.<sup>6</sup>

In contrast to the limited CNG passenger vehicle offerings, hydrogen fuel cell electric vehicle models have been announced by at least four automakers. Hyundai recently became the first automaker to commercially release a FCEV, the Tucson sport utility vehicle.<sup>9</sup> Honda, Toyota, and Mercedes-Benz have all followed suit with announcements to release light-duty hydrogen fuel cell vehicles by 2016. FCEVs have the appeal of zero tailpipe emissions, with well-to-wheels analyses projecting that FCEVs have the potential to have one of the lowest emissions of all alternative technology options as shown in Figure 1.<sup>10</sup> Moreover, FCEVs have the additional advantage of longer range than battery electric vehicle (BEV) alternatives. However, FCEVs face similar challenges to CNG vehicles in fueling infrastructure availability, which is limiting their initial introduction to regions with government programs that support hydrogen infrastructure development. Moreover, home refueling with hydrogen is not an active area of development, forcing further dependence on public infrastructure. Because of the carbon, fueling infrastructure, and business case drivers, the auto industry expects little direct competition between CNG and FCEVs for the light duty vehicle market in the U.S. Fuel cell electric vehicles will appeal more to individual consumers, and CNG vehicles will appeal to fleet vehicles. Shifts in infrastructure costs may alter this balance longer term, but the additional premium of hydrogen fueling infrastructure costs over that of natural gas will limit FCEV adoption into fleets unless a very large fleet and low cost hydrogen can support station investment.

6. *Los Angeles Times*, 9/5/2014. "Honda, Chevrolet give natural gas a push." <http://touch.latimes.com/#section/-1/article/p2p-81284505/>.

7. <http://www.fueleconomy.gov/feg/bifueltech.shtml>.

8. Argonne National Laboratory, 2012. *GREET Model (ver. 1.0.0.7950)*.

9. Hyundai USA, *Tucson Fuel Cell*. <http://www.hyundaiusa.com/tucsonfuelcell/>.

10. DOE Program Record Offices of Bioenergy Technologies, Fuel Cell Technologies, and Vehicle Technologies, 5/10/2013. *Well-to-Wheels Greenhouse Gas Emissions and Petroleum Use for Mid-Size Light-Duty Vehicles. Record # 13005 Revision #1*.

(Grams of CO<sub>2</sub>-equivalent per mile)

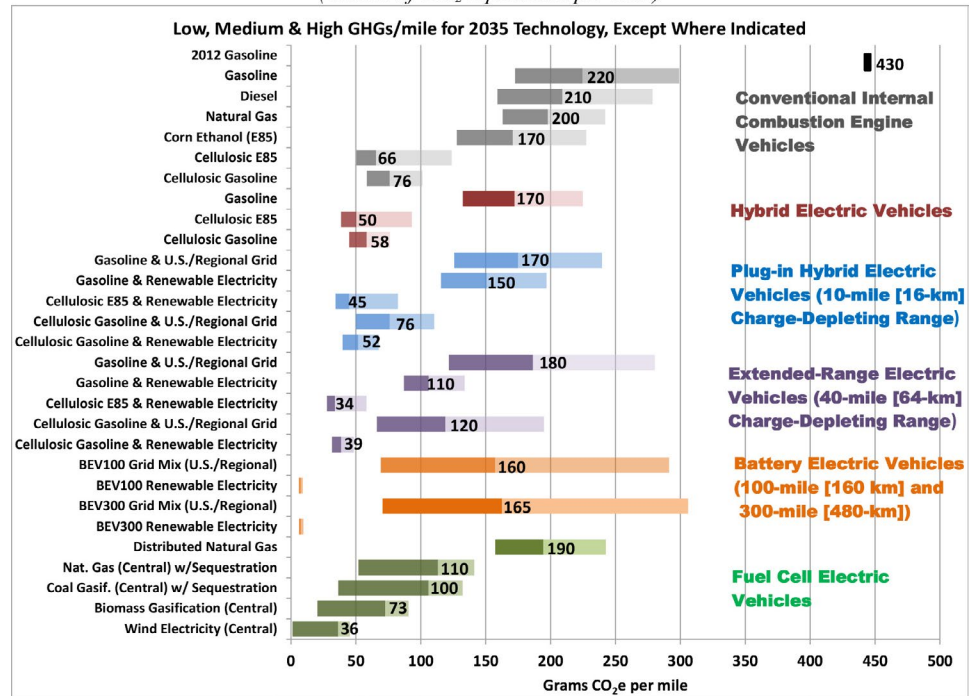

**Figure 1.** Well-to-Wheels Greenhouse Gases Emissions for 2035 Mid-Size Car. Figure from DOE Program Record Offices of Bioenergy Technologies, Fuel Cell Technologies, and Vehicle Technologies, 5/10/2013. Fuel Cell Electric Vehicles powered by hydrogen from renewable sources have the potential to be one of the cleanest alternative technologies.

In contrast to the light-duty market, medium and heavy duty vehicle sales and use are motivated by different business needs. Fleet owners invest in vehicles and infrastructure based on the best business case. They select vehicles based on vehicle type, the load requirements, and driving pattern variations. For example, different requirements emerge for stop and go package delivery versus long-haul trucking. Major freight delivery companies have made significant investments in natural gas vehicles for their heavy duty fleets. The fuel cost differential of natural gas relative to diesel has encouraged fleets to invest in the vehicles as well as in the corresponding dedicated fueling infrastructure. While this has grown demand for natural gas in the heavy duty sector, demand for other alternatives, such as FCEVs and BEVs, face significant challenges in competing for this market. Limited vehicle availability, fueling infrastructure, and high costs limit the business case for these other alternatives. Aside from natural gas vehicles, propane delivery vans are the only other alternative that has emerged with a business case for its adoption. For example, UPS has invested in over 900 propane vans despite the approximately \$10,000 cost premium over conventionally fueled vehicles. Despite these hurdles, freight companies have indicated that they have tested a variety of alternative technologies and are prepared with plans for hub locations, vehicle suppliers, and specific business applications for FCEVs and BEVs once these technologies become cost competitive.

For fleets, adoption of alternative fuels and technologies has typically only made business sense when subsidies have provided an economic incentive. Over time, the low cost of natural gas has enabled natural gas vehicles as a viable alternative based on the business case. Because of the investment in these vehicles and fueling infrastructure, these sunk costs decrease a fleet's likelihood to invest in the capital cost of a second alternative technology. Unless there is a policy requirement or significant

new economic stimulus for fuel cell or electric vehicles, and a broader set of vehicles that meet the driving business needs are deployed, it is unlikely a fleet will invest in multiple alternative technologies. However, the impact of policy drivers can be significant. For example, urban access regulations in Europe define “measures to regulate vehicular access to urban infrastructure.”<sup>11</sup> A diversity of access regulations can define pedestrian areas, loading zones, speed zones, or congestion charges for roadway access. In particular, low emission zones have been seen as a means to meet air quality targets in urban areas. In Europe, the 2011 White Paper “Roadmap Towards a single European Transport Area” established a goal of reducing the greenhouse gas emissions from transport by 60% [relative to 1990 levels] and halving the use of ‘conventionally fuelled’ cars in urban transport by 2030.<sup>12</sup> As a second example, the Clean Truck Program for the Ports of Los Angeles and Long Beach set a goal to reduce truck-related air pollution by 80 percent by 2012<sup>13,14</sup> as part of the San Pedro Bay Ports Clean Air Action Plan of 2006.<sup>15</sup> The Clean Truck Program set a schedule of fees and restrictions that banned all trucks that did not meet the 2007 federal clean truck emissions standards. Aggressive urban access regulations for emissions such as the Long Beach or European Union requirements would create new business cases for freight companies in their choice of vehicles and fuels. In particular, zero emissions requirements to access urban areas would stimulate investment in FCEVs or BEVs for those applications.

## HOW DO WE GET FUELING STATIONS BUILT? ARE THERE BUSINESS MODELS THAT CAN SIMULTANEOUSLY SUPPORT HYDROGEN AND NATURAL GAS?

Infrastructure availability is often cited as the major barrier for deploying both natural gas and hydrogen fuel cell vehicles. While existing efforts are focused on developing infrastructure for either natural gas or hydrogen, there are synergies between the two that could enable multifuel stations that support the simultaneous deployment of both alternatives. For example, utilities have developed concepts for station designs in which natural gas supplies serve as a feedstock for CNG, hydrogen, and electricity. As shown in Figure 2, the natural gas could be compressed and stored at pressure, notionally 5,000 psi, and be available for CNG refueling. The high pressure methane could also be reformed and further compressed on site to produce hydrogen at 10,000 psi, which would be available for FCEV refueling.

11. European Commission, Brussels, 17.12.2013. SWD(2013) 526 final. Commission Staff Working Document, “A call for smarter urban vehicle access regulations.”

12. European Commission, Brussels, 28.3.2011. COM(2011) 144 final. “Roadmap to a Single European Transport Area – Towards a competitive and resource efficient transport system.”

13. Port of Long Beach, Clean Trucks Program. <http://www.polb.com/environment/cleantrucks/default.asp>.

14. Port of Los Angeles, Clean Truck Program. [http://www.portoflosangeles.org/ctp/idx\\_ctp.asp](http://www.portoflosangeles.org/ctp/idx_ctp.asp).

15. San Pedro Bay Ports Clean Air Action Plan. <http://www.cleanairactionplan.org>.

Excess hydrogen could be directed to an on-site hydrogen fuel cell that could either supply electricity to the grid or charge electric vehicles.

Multifuel stations would require a compressor and high pressure gas storage tank for each gaseous fuel. Both hydrogen and CNG are well-suited for bulk storage, and advances in compression and storage technology development would facilitate the deployment of both fuels. Moreover, utilizing common equipment in station designs could accelerate advances in storage and compression technologies, as well as enable higher volume equipment production and thus cost savings through economies of scale. However, it is worth noting that there are different standards and technical challenges emerging for CNG versus hydrogen. CNG vehicles typically utilize natural gas at 5,000 psi, whereas FCEV utilize hydrogen at 10,000 psi. Rapid refueling times, similar to conventional fuels, necessitate these high pressures. Hydrogen faces the additional challenge of embrittling steel, and thus requires higher quality storage materials than natural gas. Because of the lower pressures and less stringent materials requirements, natural gas infrastructure and vehicles currently have a lower cost premium than that of hydrogen. Nonetheless, it is worth exploring the potential cost savings associated with common equipment rather than creating separate infrastructure equipment supply chains for each alternative.

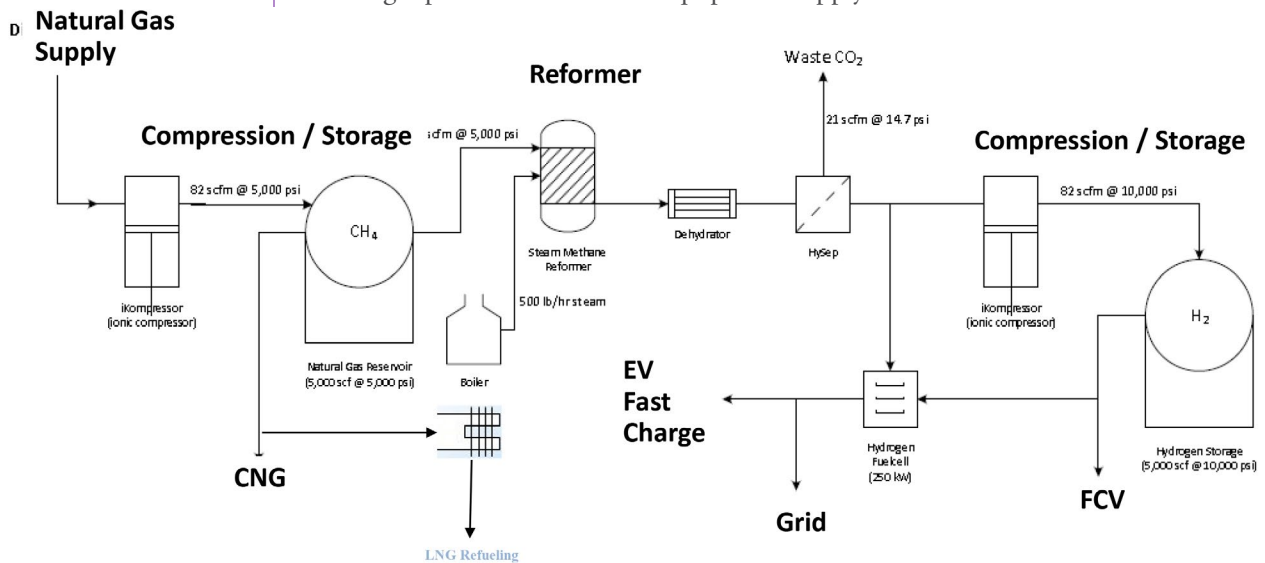

**Figure 2.** Concept for multifuel station that utilizes natural gas to produce three fuel streams: CNG, hydrogen, and electricity that can either charge electric vehicles or be fed to the grid. Figure courtesy of Jeff Reed, Southern California Gas Company.

Co-location of multiple fuels at a single station also creates multiple revenue streams and thus opportunities for new business models. Over the next several years, stations will be subject to low and inconsistent demand with relatively few CNG and FCEVs in circulation. Building infrastructure has been slow due to the uncertainty and likely low rates of return in these investments. The additional co-production of electricity, links to other sustained demands for hydrogen at more predictable levels, and CNG produced on site can help provide additional revenue streams that support the infrastructure investment during times when demand for any one of these alternatives is low and inconsistent. In addition, incorporating small, modular hydrogen storage systems of 50-100 kg as a source for mobile electricity has the potential to further reduce the risk of on-site hydrogen production.



Furthermore, compared to petroleum-based fuels, for which the feedstock accounts for roughly 80% of fuel cost, only about 35% of the cost of CNG is attributed to the feedstock. Even with the additional costs of processing and distribution, CNG is a relatively high margin fuel. While current estimates for hydrogen feedstock vary from \$4-\$12 to produce a gallon of gasoline equivalent fuel, the possible lowering of feedstock costs and improved processing and storage technologies over time may also enable hydrogen to emerge as a high margin fuel.



Craig Scott (Toyota), Jeff Reed (Southern California Gas Company), Frank Wolak (Fuel Cell Energy) and Prabhu Rao (Nuvera) discussed opportunities for natural gas and hydrogen fuel infrastructure development.

As panel discussants, they stimulated a conversation on new business models that have the potential to enable fueling stations with multiple alternative fuels.

Natural gas and hydrogen infrastructure development is bringing new players into the marketplace. While conventional fuel stations have a fairly monolithic set of suppliers and providers, natural and hydrogen stations are likely to require new stakeholders with new roles. For example, while utilities traditionally supply gas and electricity to homes and businesses, they have also been required by policy to develop CNG fueling stations and subsequently divest based on further policy shifts. In addition, current expectations for rates of return for hydrogen stations are about 10-15%, which is relatively low given the perceived risk of variable market demand and policy uncertainty. Typical venture capital investments require much higher returns given the perceived risk. Looking forward, new business models may bring together utilities, industrial gas companies, and customer service providers, and thus create new partnerships that change the factors that contribute to station profitability. Multi-fuel stations, carbon pricing, and the likely link between electricity and hydrogen production are additional factors that will alter the fueling infrastructure landscape. Policies affecting carbon intensity of electricity production will also affect hydrogen production. For example, regions with zero emission vehicle mandates that also have combined gas and electric utilities may establish economic incentives to produce hydrogen. One initial concept is that small amounts of hydrogen may be co-produced with electricity and stored until needed to fuel vehicles. Over time, the relative amounts of electricity and hydrogen produced can shift to meet growing hydrogen fuel demand.

New partnerships have already emerged to facilitate the expansion of infrastructure and vehicles for hydrogen and natural gas independent of the other. For example,

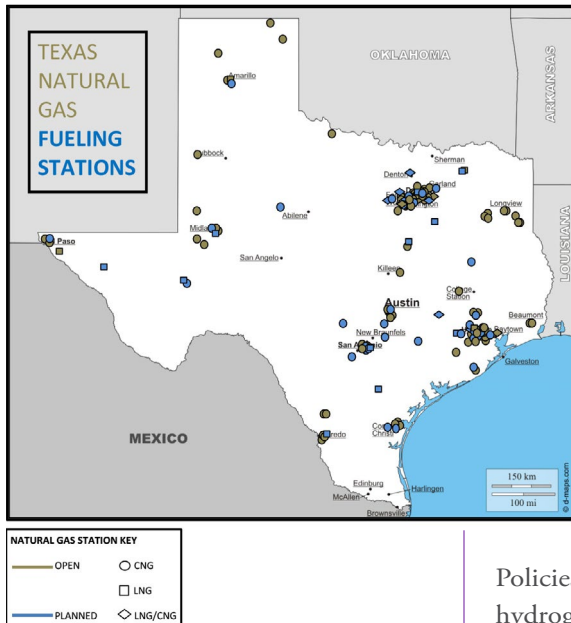

**Figure 3.** Natural gas stations in Texas as of September 8, 2014. Image from Railroad Commission of Texas. <http://www.rrc.state.tx.us/about-us/commissioners/porter/news/090814b/>.

in November 2014 Air Liquide announced plans to deploy a network of at least twelve fully-integrated hydrogen fueling stations in the U.S. in order to support Toyota’s introduction of the Mirai FCEV.<sup>16,17</sup> The stations provide a refuel time of less than 5 minutes to support FCEVs with up to 300 miles of range. Development of multi-fuel stations will likely stimulate additional partnerships between fuel providers and vehicle manufacturers.

### WHAT CAN WE LEARN FROM PROGRAMS AND POLICIES THAT HAVE BEEN IMPLEMENTED AT THE STATE LEVEL?

Policies and incentives in California and Texas are accelerating the deployment of hydrogen and natural gas for transportation, respectively. Texas set a goal to ensure that there were sufficient natural gas vehicles and refueling stations to support goods movement across three major cities – Dallas, Houston, and San Antonio. Their initial goal was to have eight stations and 550 heavy trucks to connect this “Texas Triangle,” and the Texas Commission on Environmental Quality provided grants to offset the cost of infrastructure and vehicles. Initially, approximately 80% was dedicated to replacing heavy- and medium-duty diesel vehicles with CNG and LNG vehicles through their Texas Natural Gas Vehicle Grant Program (TNGVGP), and 20% was dedicated to infrastructure investment through their Clean Transportation Triangle (CTT) and Alternative Fueling Facilities Program (AFFP).<sup>18</sup> These goals were quickly surpassed, leading to over 100 natural gas stations as shown in Figure 3. Their approach of aligning stakeholders and creating both demand and supply for natural gas lowered the risk for infrastructure investment. They exceeded their initial goals and enabled new players to enter the market. While initial program participants were larger companies, participation has expanded into small businesses and single station owner operators. Once a sufficient number of natural gas trucks were on the road, demand



Compressed natural gas filling station in Texas. Figure courtesy of Lynn Lyon, Pioneer Natural Resources.

16. Air Liquide plans network of new hydrogen filling stations in the United States. November 17, 2014.

17. Toyota has announced the release of the Mirai in U.S. markets for 2015. November 17, 2014.

[http://toyota-global.com/innovation/environmental\\_technology/fuelcell\\_vehicle/](http://toyota-global.com/innovation/environmental_technology/fuelcell_vehicle/).

18. Texas Commission on Environmental Quality. <http://www.tceq.texas.gov/airquality/terp>.

Figure 4. Current and estimated progress for hydrogen station network in California. Figure from California Fuel Cell Partnership.<sup>23</sup>

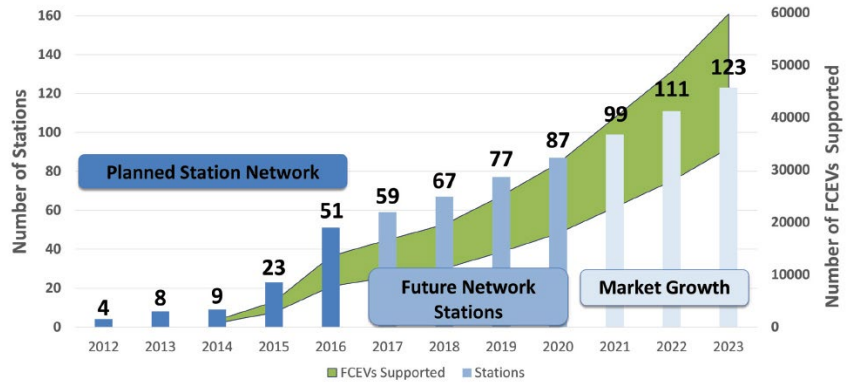

Air Products' SmartFuel H70/H35 hydrogen retail dispenser.

and margins became high enough for fueling stations to become profitable without subsidies. Moreover, since the natural gas stations are required to be accessible for public refueling, small businesses are gaining interest in natural gas vehicles knowing that the fuels are readily available. For Texas, stimulating sufficient demand created the market conditions for infrastructure development. They are building upon this success by continuing the TNGVGP program into FY15.

California's Zero Emission Vehicle mandate has encouraged several major auto manufacturers to introduce FCEVs into the marketplace. While only Hyundai has released a FCEV,<sup>19</sup> which is available to consumers in select Southern California markets, additional offerings have been announced by other automakers.<sup>20</sup> The California Fuel Cell Partnership is projecting vehicles to grow from the hundreds currently on road to 6,500 by 2017, and 18,000 by 2020. In parallel, in 2013 Assembly Bill 8 extended state programs to invest in the development and deployment of advanced technologies needed to meet California's air quality, climate and energy goals through 2024.<sup>21</sup> The bill dedicates up to \$20M annually to support the continued construction of at least 100 hydrogen fuel cell stations. The California Environmental Protection Agency and Air Board expect that a network of 51 hydrogen stations will be in place by 2016, as illustrated in Figure 4.<sup>22</sup> As part of this expansion, they are beginning to see common station designs rather than one-of-a-kind stations, indicating increasing sophistication in infrastructure development. The combination of ZEV credits and infrastructure investments are intended to simultaneously support the critical mass of vehicles and fueling stations that ultimately become self-sustained by the market rather than by subsidies.



Toyota announced that the Fuel Cell Mirai will be released in the U.S. in 2015.

19. <http://www.hyundaiusa.com/tucsonfuelcell>

20. In addition to Toyota's announcement to release the Mirai in the U.S. in 2015, Honda has also announced the next-generation FCX Clarity for 2016. <http://automobiles.honda.com/fcx-clarity/>.

21. California Assembly Bill No. 8, Chapter 401, 2013.

22. California Environmental Protection Agency, Air Resources Board, June 2014. "Annual Evaluation of Fuel Cell Electric Vehicle Deployment and Hydrogen Fuel Station Network Development."

23. California Fuel Cell Partnership, July 2014. "A California Road Map. The Commercialization of Hydrogen Fuel Cell Vehicles 2014 Update: Hydrogen Progress, Priorities and Opportunities (HyPPO) Report."



## FURTHER CHALLENGES AND OPPORTUNITIES

While the workshop was focused on the three major questions related to hydrogen and natural gas market segmentation, infrastructure business models, and state lessons learned, several other recommendations that could support the development of these alternative technologies emerged from the discussion. Key highlights are summarized below:



Kathryn Clay (AGA), Catherine Dunwoody (California Air Resources Board), Lynn Lyon (Pioneer Natural Resources), and Glen Andersen (National Conference of State Legislatures)

### Conduct thorough system requirements and cost assessments to quantify the benefit of co-development of natural gas and hydrogen.

A number of technical and policy barriers will affect the broader deployment of alternative fuels and infrastructure. While the relatively low cost and abundant supply of natural gas has stimulated deployment, uncertainty in fuel costs, vehicle incentives, and technology investments continue to limit hydrogen vehicles and infrastructure. While existing analyses point to these barriers for hydrogen,<sup>24</sup> additional systematic assessments that elucidate the sensitivities and relative significance of the barriers would

help inform a path forward for the development of both natural gas and hydrogen, as well as the potential benefits for multi-fuel stations and common designs for storage and compression technologies. Moreover, utilization of common pipelines for supply and distribution of natural gas and hydrogen provide another possible opportunity for synergistic infrastructure. Just as petroleum pipelines carry many different crude products of varying quality, the current natural gas infrastructure has the potential to be utilized for hydrogen distribution in addition to natural gas. Exploring the economics of scale for common designs, manufacturing, and distribution can quantify the impact of co-development.

**Leverage codes and standards development.** The first hydrogen dispensers have been certified to sell hydrogen by the kilogram, which is the energy equivalent of a gallon of gasoline. This translation enables consumers to make a straightforward cost comparison between hydrogen and conventional fuels. However, metering has emerged as a challenge for natural gas. While the natural gas industry supports the sale of natural gas in gallons of gasoline equivalent so that consumers can make a direct cost comparison between natural gas and conventional fuels, government entities that develop and apply measurements and standards advocate a more universal metric, such as kilograms, that can be measured more precisely. Resolving this difference to provide accurate and consumer-friendly fuel metering will help facilitate consumer adoption of fuels.

24. See for example T. Eckerle, R. Gardaret, June 19, 2012. "Incentivizing Hydrogen Infrastructure Investment. Phase 1: An Analysis of Cash Flow Support to Incentivize Early Stage Hydrogen Station Investment."



In addition to metering of fuels, lessons learned from developing codes and standards for hydrogen could be applied to natural gas. For example, methodologies to quantify hydrogen fuel quality are currently better established than those in place for CNG. Taking advantages of these common learnings can enable technical specifications such as fuel quality to be developed more rapidly and efficiently for these evolving fuel streams.

**Provide clear choices, but not too many of them.** The role of consumer choice and their mental accounting of the value of the various benefits of alternative vehicles will have a significant impact on the adoption of hydrogen and natural gas vehicles. Bundling of products and services is a popular marketing practice designed to appeal to consumers and streamline choices, including in consumers' evaluation of automobile offerings.<sup>25</sup> Similarly, adoption of the Energy Star certification for consumer products provides clear, binary information on their certified energy efficiency.<sup>26</sup> Providing straightforward, clear information to consumers on the value of alternative technologies and their benefits can help facilitate their adoption.

---

25. M.D. Johnson, A. Herrmann, H.H. Bauer, 1999. "The effects of price bundling on consumer evaluations of product offerings." *Intl. J. of Research in Marketing*, vol. 16, issue 2, pp. 129-142.

26. <http://www.energystar.gov/>

## MEETING OBJECTIVES:

Convene industry and other stakeholders to explore infrastructure requirements, regional trends, and tradeoffs and opportunities at the intersection of hydrogen fuel cell and natural gas use for on road transportation. Identify synergies between natural gas and hydrogen fuels.

Identify key challenges (both technical and non-technical, such as policies and standards) preventing or delaying the widespread deployment of natural gas and hydrogen.

Identify and prioritize opportunities to address these challenges, and determine roles and opportunities to partner across both government and industry stakeholders.

## APPENDIX 1

### Agenda:

#### 8:00a Registration and Continental Breakfast

#### 8:30a Welcome and Introductions

Dawn Manley, Senior Manager for Chemical Sciences, Sandia National Laboratories  
Kathryn Clay, Vice President for Policy Strategy, American Gas Association

#### 9:00a Workshop Goals, Objectives, and Desired Outcomes

Reuben Sarkar, Deputy Assistant Secretary for Transportation,  
U.S. Department of Energy

#### 9:15a Federal Perspective on Opportunities for Hydrogen for Transportation – Including a Natural Gas Perspective

Fred Joseck, Systems Analysis Project Manager, Fuel Cell Technologies Office,  
U.S. Department of Energy

#### 9:25a Federal Perspective on Opportunities for Natural Gas for Transportation – Including a Hydrogen Perspective

Mark Smith, Clean Cities Program, Vehicle Technologies Office,  
U.S. Department of Energy

#### 9:35a Workshop Primer: Summary Highlights and Group Discussion

Todd West, Technical Manager, Sandia National Laboratories

#### 10:15a Panel Discussion #1: For what markets are natural gas and hydrogen in direct competition, and how might they be better suited for different transportation applications?

Joan Ogden, Associate Professor of Environmental Science and Policy, UC Davis  
Jim Bruce, Senior Vice President of Corporate Public Affairs, UPS  
Jim Kliesch, Environmental Regulatory Affairs Manager, Honda

#### 11:00a Panel Discussion #1 Follow-On Breakout Discussion

- For what markets are natural gas and hydrogen in direct competition, and how might they be better suited for different transportation applications?
- What are best practices and policies for infrastructure rollout? (Hydrogen has been proposed in “clusters” to enable a critical mass of stations & vehicles in close proximity, whereas natural gas infrastructure is being built to support long-haul trucking. Both may compete for fleets with centralized refueling.)
- How should hydrogen and natural gas contribute to the diversity of transport needs?

## Agenda (cont'd):

**12:00p Lunch**

**1:00p Panel Discussion #2: How do we get fueling stations built? Are there business models that can simultaneously support hydrogen and natural gas?**

Frank Wolak, Vice President, Fuel Cell Energy

Jeff Reed, Director of Business Strategy & Advanced Technology,  
Southern California Gas

Prabhu Rao, Vice President & Chief Commercial Officer, Nuvera

**1:45p Panel Discussion #2 Follow-On Breakout Discussion**

- What are the intersections between natural gas and hydrogen infrastructure development for use in natural gas and hydrogen fuel cell vehicles?
- How are they synergistic, and how do they compete?
- What technological and policy developments can influence this?

**2:30p Report-Out from Breakouts**

**3:15p Panel Session #3: Case Studies and Lessons Offered at the State Level**

Catherine Dunwoody, Chief, Fuel Cell Program, California Air Resources Board

Lynn Lyon, Fuel Market Development Director, Pioneer Natural Resources

Glen Andersen, Energy Program Director, National Conference of State Legislatures

**4:00p Panel Discussion #3 Follow-On Plenary Discussion**

**4:45p Summary and Report Next Steps**

Dawn Manley, Sandia National Laboratories

**5:00p Workshop Conclusion**

**5:30p Reception**

Charlie Palmer Steak DC

101 Constitution Ave, NW

Washington, DC 20001

**6:00p Dinner**

## APPENDIX 2

## Workshop Primer

# Transitioning the Transportation Sector:

# Exploring the Intersection of Hydrogen Fuel Cell and Natural Gas Vehicles

September 9, 2014

American Gas Association, 400 N. Capitol St., NW, Washington, DC 20001

Organized in partnership by:

Sandia National Laboratories, AGA and Toyota, in support of the U.S. Department of Energy

### Contents

#### Executive Summary

#### Part 1: Natural Gas

1. *What is natural gas, and why consider natural gas for transportation?*
2. *Current state of technology and deployment*
  - Vehicles
  - Infrastructure
3. *Opportunities and challenges*
  - Cost
  - Efficiency
  - Safety
  - Environmental considerations
4. *References*

#### Part 2: Hydrogen

1. *What is a hydrogen fuel cell vehicle, and why consider hydrogen for transportation?*
2. *Current state of technology and deployment*
  - Vehicles
  - Infrastructure and hydrogen production
3. *Opportunities and challenges*
  - Cost
  - Storage technologies
  - Durability
  - Safety
  - Environmental considerations
4. *References*

Prepared by Garrett Barter,  
Dawn Manley, Todd West  
[dmanley@sandia.gov](mailto:dmanley@sandia.gov)  
(925) 294-4589

SAND2014-17287C

### Executive Summary

This workshop will explore infrastructure requirements, regional trends, and tradeoffs and opportunities at the intersection of hydrogen fuel cell and natural gas use for on road transportation. The goal of the workshop is to provide background and context for thinking through the dynamic evolution of these two transportation options in tandem.

This Primer provides a brief summary of these alternative fuels and vehicles. It is intended to serve as an introduction for workshop participants who may be less familiar with either natural gas or hydrogen for transportation. While this executive summary provides a very cursory introduction to each technology, the remainder of the primer provides additional background. The two parts can be read independently; Part 1 reviews natural gas, and Part 2 reviews hydrogen. Together, they provide a baseline background on each transportation alternative.

#### Natural Gas

Natural gas, composed primarily of methane, is extracted from oil and gas wells via drilling as well as from shale formations via hydraulic fracturing. Throughout the continental US, it is delivered through a 300,000 mile transmission network, with another 1.9 million miles that support the utility service areas. As a domestic resource, natural gas is attractive for reducing oil imports and because of its low carbon:hydrogen ratio and high thermal efficiency in combustion (MIT 2011). Light duty natural gas vehicles (NGVs) have 25% lower CO<sub>2</sub> emissions profiles relative to conventional vehicles, and medium- and heavy-duty vehicles (HDVs) running on natural gas also have lower emissions of particulates, NO<sub>x</sub>, CO<sub>2</sub>, and hydrocarbons (ANL 2010).

Since natural gas is a gaseous fuel at atmospheric conditions, it occupies a large volume relative to liquid fuels. It is thus stored on vehicles at high pressure as compressed natural gas (CNG) or as a liquefied natural gas (LNG), which increases the cost and weight of NGVs relative to gasoline or diesel. It takes 3.8 gallons of CNG or 1.7 gallons of LNG to equal the energy content of a gallon of diesel. In these forms, the storage requirements are still greater than gasoline or diesel, thus NGVs typically have increased weight and purchase costs, and slightly lower fuel economy and range (ANL 2010). Moreover, light-duty gasoline tanks typically conform to the underside of the chassis, whereas CNG tanks are essentially cylindrical pressure vessels that displace trunk space. At 3600 psi and 70°F, a CNG tank is about 3.8 times larger and 2-5 times heavier than a gasoline tank with the same energy content (NRC 2013). For HDVs, CNG and LNG both have lower energy density than diesel, so a single tank provides a shorter range than traditional vehicles. LNG tanks give Class 8 trucks about a 300 mile range, half that of diesel counterparts (TIAX-LNG). Reduced range can be a concern, since refueling time can add to operational costs.

About 112,000 vehicles in the US and 14.8 million worldwide are powered by natural gas (DOE AFDC). Of these vehicles, the majority are LDVs with about 15,000 heavy trucks (BNEF 2014). The



relatively few light duty NGV models offered by manufacturers can limit adoption rates (Peterson 2014). There are 743 public CNG stations and over 1400 including private installations in the US. The large number of private stations reflects CNG's adoption among fleet owners conducting regional operations; centralized refueling of CNG-powered vehicles can take advantage of lower cost technologies that refuel over several hours. In addition, home refueling appliances are available to homes equipped with natural gas. There are 58 public LNG stations, with biased deployment in California, Utah, Texas, and select highway corridors. While all natural gas nozzles and vehicle receptacles are designed to keep fuel from escaping during refueling by locking together to form a sealed system, the refueling infrastructure needed for LNG or CNG can be quite different. CNG refueling stations require noisy compressors, which consume significant electricity, and compressed gas storage tanks. Thus, CNG stations have higher costs and space requirements than gasoline or diesel stations. LNG uses dispensers that are more similar to those used for gasoline or diesel. However, when filling with LNG, the user must wear protective clothing, a face shield, and gloves. LNG stations have additional complications, such as tank truck offloading, cryogenic fuel storage, vapor management, and venting minimization (TIAX-LNG). Liquefaction of natural gas requires cooling to  $-260^{\circ}\text{F}$  and filtering to remove impurities, and is thus most efficiently done in centralized facilities and then delivered by truck to fueling stations (ANL 2010).

For heavy-duty vehicles (HDVs) using CNG or LNG, the annual mileage can be high enough such that fuel cost savings can offset purchase premiums in 1.5-3 years. Model availability is less of an issue for HDVs, as most new trucks are made to order. The benefits of the lower emission profile should not be understated for HDVs operating in controlled air quality districts. For instance, tight restrictions on pollutants at the Ports of Long Beach and Los Angeles in California compelled many Class 8 tractor-trailer operators to switch to NGVs (NPR 2012). However, while natural gas burns more cleanly and has lower tailpipe emissions relative to gasoline and diesel, analyses suggest that methane leakage across the supply chain may mitigate these benefits (Alvarez 2012).

#### Hydrogen

Hydrogen is one of the most abundant elements on earth. It is a colorless, odorless, tasteless, and nontoxic gas (NPC 2012). A kilogram of hydrogen gas contains the energy equivalent of a gallon of gasoline. Hydrogen is not an intrinsic energy source, but is a secondary energy carrier similar to electricity (Ball 2009). Consequently, the advantages of using hydrogen as a fuel depend upon how it is produced. As an industrial commodity in the US, hydrogen is produced at a rate of 10 million tons per year for chemical processing and refining crude oil in large facilities closely associated with the end use (NRC 2013). Over 95% of this hydrogen is made from natural gas via steam methane reforming (NRC 2013). In this process, natural gas is broken down in a reaction with high temperature steam in the presence of a catalyst to produce a hydrogen-rich gas and  $\text{CO}_2$ , which is typically released to the atmosphere. Nevertheless, the per-mile, well-to-wheel GHG footprint of fuel cell electric vehicles (FCEVs) is approximately 50% lower, when using natural gas as the feedstock, than that of a conventional gasoline vehicle (NPC 2012). Increased adoption of FCEVs can also contribute to substantial reductions in urban pollution from soot,  $\text{NO}_x$ , and  $\text{SO}_x$ .

A fuel cell is an electrochemical device that converts chemical energy from a fuel to electric energy with no combustion involved. A FCEV is an all-electric vehicle similar to a battery electric vehicle (BEV) except that the electric power comes from a fuel cell system with on-board hydrogen storage. Thus, the vehicle's power and stored energy capacity can be controlled separately rather than being tied to battery size (DOE AFDC). Polymer electrolyte membranes (PEMs) are the most common type of fuel cell for vehicles, and compressed gas at 5,000 psi or 10,000 psi has emerged as the primary technology path (Jorgensen 2011).

The attractiveness of FCEVs is similar to the benefits of BEVs. FCEVs offer zero tailpipe emissions, an alternative to petroleum, and a pathway to renewable and sustainable transportation. The byproduct of a fuel cell is just water. FCEVs generally have driving ranges comparable to ICEs, have efficiencies around twice that of ICEs, are scalable to all vehicle sizes, and have refueling times similar to that of gasoline vehicles. Hyundai recently became the first automaker to commercially

release a FCEV, and several other companies (e.g. Daimler, Honda, and Toyota) have announced plans to introduce FCEVs commercially starting in 2015.

In the US, there are 12 public hydrogen stations currently registered with DOE, and California has announced plans to build 25 more to support the deployment of FCEVs (DOE AFDC). Until a large number of FCEVs are in use, the cost of hydrogen as a fuel will be high due to upfront infrastructure costs. Current estimates for pump prices of hydrogen are \$3.50-\$6 per gge (NRC 2013). However, these costs assume high-volume production to support 10 million FCEVs. Initial hydrogen costs could be as much as \$9-\$12/gge, more closely reflecting the cost of using centralized industrial hydrogen production for transportation (NPC 2012). The current production supports large quantities of hydrogen delivery to a few users, instead of small quantities distributed to many dispersed users. For distributed production at refueling stations, the subsequent compression of hydrogen presents land, maintenance, and capital challenges. A typical compression system requires  $\sim 100 \text{ ft}^2$  of space, should be located where equipment noise is either not a concern or can be buffered, and contributes 20 to 50% of the total cost of the fueling station (NPC 2012). Regardless of the production paradigm, hydrogen must be stored at high pressure. This is typically done with a cascade of high pressure steel tubes on concrete slabs. Based on demonstration hydrogen stations built to date, a traditional steel tube storage system with a 300 kg storage capacity occupies  $\sim 450 \text{ ft}^2$ , not including setback requirements.

In addition to developing infrastructure and the supporting safety standards and codes, current research and development efforts for FCEVs are focused on technological improvements to lower costs and address safety concerns. The high vehicle cost stems primarily from the use of platinum catalysts and the carbon-fiber storage tanks. The compressed gas storage capacity, and hence the vehicle driving range, is limited by the volume and cost of tanks that can be packaged in vehicles. Moreover, increased longevity of fuel cell stacks is needed for commercial success. The electrolyte membrane is sensitive to stress, harmful chemical exposure, or high-current hot spots, and the fuel cell stack is subject to degradation over usage cycles and calendar life. The safety challenges for FCEVs and refueling stations stem from high voltage electrical equipment, high pressure gas storage, and the combustion risk of hydrogen. The safety of high voltage electric power is managed on FCEVs similarly to EVs, where safety requirements have resulted in on-road safety statistics comparable to that of conventional vehicles (NRC 2013). While fire risk is somewhat mitigated because hydrogen dissipates much faster than gasoline fumes, hydrogen is far more easily ignited than natural gas or gasoline and burns with a nearly invisible flame (NPC 2012).



## Part 1: Natural Gas

1. *What is natural gas, and why consider natural gas for transportation?*
2. *Current state of technology and deployment*
  - Vehicles
  - Infrastructure
3. *Opportunities and challenges*
  - Cost
  - Efficiency
  - Safety
  - Environmental considerations
4. *References*

## Part 1: Natural Gas

### What is natural gas, and why consider natural gas for transportation?

Natural gas, composed primarily of methane, is extracted from oil and gas wells via drilling as well as from shale formations via hydraulic fracturing. The natural gas is then separated and processed to meet quality standards for water content, hydrocarbon dewpoint, heating value, and hydrogen-sulfide content (DOE AFDC). Throughout the continental US, it is delivered through a 300,000 mile transmission network, with another 1.9 million miles that support the utility service areas.

As a domestic resource, natural gas is attractive for reducing oil imports, and as a fossil fuel it is attractive because of its low carbon:hydrogen ratio and high thermal efficiency in combustion (MIT 2011). Natural gas vehicles (NGVs) have cleaner tailpipe emissions profiles relative to conventional gasoline and diesel vehicles. For light-duty vehicles (LDVs), the total CO<sub>2</sub> emissions are approximately 25% less per mile traveled than a gasoline engine (MIT 2011). Medium- and heavy-duty vehicles (HDVs) running on natural gas also have lower emissions of particulates, NO<sub>x</sub>, CO<sub>2</sub>, and hydrocarbons (ANL 2010).

Since natural gas is a gaseous fuel at atmospheric conditions, it occupies a large volume relative to liquid fuels. It is thus stored on vehicles at high pressure as compressed natural gas (CNG) or as a cooled liquid as liquefied natural gas (LNG), which increases the cost and weight of NGVs relative to gasoline or diesel. It takes 3.8 gallons of CNG or 1.7 gallons of LNG to equal the energy content of a gallon of diesel.

Despite the additional vehicle cost and weight, the lower fuel prices can make NGVs attractive for many applications. Over the past several years, CNG has been about 50-70% and LNG has been 80-90% the price of an energy equivalent amount of diesel. The Energy Information Administration projects that natural gas will offer a significant fuel cost savings over gasoline and diesel through at least 2040 (AEO 2014). Moreover, the Potential Gas Committee's most recent assessment estimated that as of 2012, the US possesses a technically recoverable resource base of 2,384 trillion cubic feet, the highest estimate ever (PGC 2013). This is enough gas for decades, if not a century of use, even if NGVs became more commonplace. For example, if 10% of all US LDVs in 2035 were NGVs, it would represent a 2.8% increase in total US natural gas demand for that year (NRC 2013).

### Current state of technology and deployment

#### Vehicles

Natural gas vehicles are among the most immediately attainable alternative fuel vehicles (AFVs) for medium and heavy duty applications. To date, LNG has been used exclusively by heavy-duty Class 8 trucks, whereas CNG has been used across light-, medium-, and heavy-duty applications. About 112,000 vehicles in the US and 14.8 million worldwide are powered by natural gas (DOE AFDC). Of these vehicles, the majority are LDVs with about 15,000 heavy trucks (BNEF 2014). Despite the maturity of NGV technology, there are relatively few light duty NGV models offered by manufacturers, which can limit adoption rates (Peterson 2014). According to the DOE Alternative Fuels Data Center, the only model year 2014 LDVs available are the Chevy Express and GMC Savana vans, and the Honda Civic GX is the only dedicated sedan. Model availability is less of an issue for heavy-duty vehicles (HDVs), as most new trucks are made to order. Cummins Westport, Inc. and Westport Innovations are the primary developers of large displacement, heavy-duty natural gas engines (ANL 2010). A number of manufacturers offer trucks built around these engines, including Peterbilt, Freightliner, Kenworth, Mack Trucks, Navistar, Volvo, and many others (Cummins).

Natural gas can be burned directly in an internal combustion engine (ICE) as a spark-ignited gaseous fuel or in a high-pressure compression-ignition diesel cycle. NGVs can run exclusively on natural gas, as a bi-fuel vehicle for which there are separate fuel tanks for natural gas and either gasoline or diesel, or in a dual-fuel mode, typically limited to heavy duty applications, in which diesel is used to assist ignition (DOE AFDC).

Prepared by Garrett Barter  
and Dawn Manley

A CNG fuel system lowers high-pressure gas from the storage tank to the operating pressure of the engine. The gas is then injected into the engine similar to the way gasoline is injected into a gasoline engine. The driving experience, engine, and powertrain are thus largely identical to a gasoline model. This is in contrast to other alternative fuel vehicles (AFVs), such as electric vehicles (EVs) or fuel cell electric vehicles (FCEVs), and makes NGVs easily accessible.

Even in these forms, the storage requirements are still greater than gasoline or diesel, thus NGVs typically have increased weight and purchase costs, and slightly lower fuel economy and range (ANL 2010). Natural gas storage costs are the primary contributor to NGV purchase premiums. CNG tanks are typically made out of solid steel, to maintain an internal pressure of 3600 psi, while also being safe enough to withstand damage from a collision (NRC 2013). Type 3 cylinders use thinner metal liners wrapped in composite, but are more expensive. Tanks with polymer liners are more expensive still (NRC 2013). LNG tanks are not typically actively cooled, so they must be able to hold a cryogenic liquid and prevent evaporation. LNG tanks are typically double-walled steel tanks with a vacuum-insulation layer, and also require regulators to manage the pressure of the liquid-vapor.

In addition to higher cost, the storage systems are heavier and take up more space than those for gasoline or diesel. Light-duty gasoline tanks typically conform to the underside of the chassis. CNG tanks are essentially cylindrical pressure vessels and have displaced trunk space. At 3600 psi and 70°F, a CNG tank is about 3.8 times larger and 2-5 times heavier than a gasoline tank with the same energy content (NRC 2013). This reduces usable trunk space to the consumer and the increased weight reduces fuel efficiency (ANL 2010). For example, the Honda Civic GX CNG tank holds 2-3 gallons of gasoline equivalent (gge) less than the gasoline LX trim version. For HDVs, CNG and LNG both have lower energy density than diesel, so a single tank has a shorter range than traditional vehicles. LNG tanks give Class 8 trucks about a 300 mile range, half that of diesel counterparts (TIAX-LNG). Reduced range can be a concern, especially for long-haul trucks, since refueling time can add to operational costs. For HDVs to achieve similar ranges before refueling, larger tanks or even multiple tanks are used. This adds significant cost and weight to the vehicle and reduces fuel efficiency and available freight capacity. Research into advanced storage methods includes higher pressure storage (to reduce space), or adsorption in activated carbon or other sponge-like material at lower pressure to allow for conformal tank shapes (NRC 2013).

### **Infrastructure**

According to the DOE AFDC, there are 743 public CNG stations and over 1400 including private installations in the US. The large number of private stations reflects CNG's adoption among fleet owners conducting regional operations; centralized refueling of CNG-powered vehicles can take advantage of lower cost slow-fill technologies. In addition, home refueling appliances are available to homes equipped with natural gas. There are 58 public LNG stations, with biased deployment in California, Utah, Texas, and select highway corridors.

Natural gas infrastructure for transportation is significantly aided by the fact that natural gas transmission pipelines already exist for electric power, industrial, commercial, and residential purposes. While NGV stakeholders will likely not have to fund significant new natural gas transmission pipelines, the cost of installing CNG or LNG dispensers can still be daunting. LNG station cost data are scattered, but roughly scale from \$0.35M-\$1.5M, depending on desired storage capacity (TIAX-LNG); CNG refueling installation costs are similar, ranging from \$0.5M-\$1M, depending on capacity (TIAX-CNG). These costs are an order-of-magnitude greater than gasoline or diesel infrastructure costs (NRC 2013).

All natural gas nozzles and vehicle receptacles are designed to keep fuel from escaping during refueling by locking together to form a sealed system. However, the refueling infrastructure needed for LNG or CNG can be quite different. CNG refueling stations can be time-fill or fast-fill (DOE AFDC). Time-fill stations take fuel from a utility line and use a compressor to raise the gas to high pressure. Fuel is typically dispensed to the vehicle directly from the compressor, which enables a lower heat of recompression and thus enables a fuller fill than fast-fill. Time-fill stations utilize a small buffer tank to improve energy efficiency and reduce wear by prevent the compressor from cycling off and on.



Fast-fill stations use a high-powered compressor. The CNG is stored in and dispensed from a series of storage tanks at high pressure (4,300 psi), which enables a fill time comparable to gasoline fueling. The CNG compressors are noisy and consume significant electricity. Combined with the storage requirements needed for fast-fill, stations require significantly more space than gasoline or diesel fueling infrastructure.

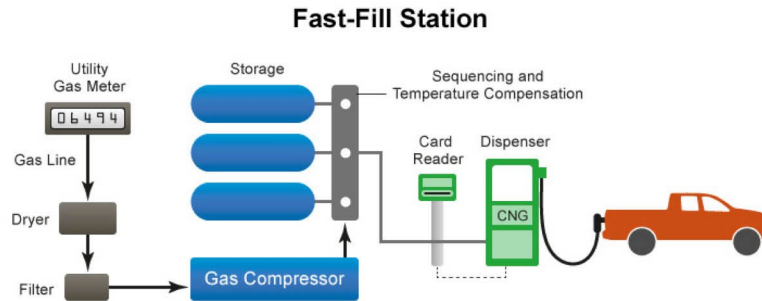

CNG fast-fill station configuration. Image from DOE Alternative Fuels Data Center [http://www.afdc.energy.gov/fuels/natural\\_gas\\_cng\\_stations.html](http://www.afdc.energy.gov/fuels/natural_gas_cng_stations.html)

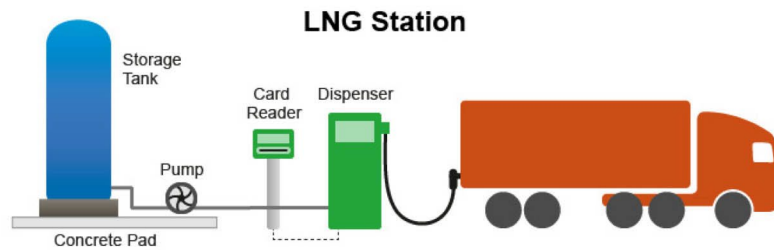

LNG station configuration. Image from DOE Alternative Fuels Data Center [http://www.afdc.energy.gov/fuels/natural\\_gas\\_infrastructure.html](http://www.afdc.energy.gov/fuels/natural_gas_infrastructure.html)

LNG uses dispensers that are more similar to gasoline or diesel. It is a liquid fuel dispensed at 30-120 psi (DOE AFDC). When filling with LNG, the user must wear protective clothing, a face shield, and gloves. LNG stations have additional complications, such as tank truck offloading, cryogenic fuel storage, vapor management, and venting minimization (TIAX-LNG). Liquefaction of natural gas requires cooling to temperatures of  $-260^{\circ}\text{F}$  and filtering to remove impurities, and is therefore most efficiently done in a dedicated, centralized facility and is normally delivered by truck to fueling stations (ANL 2010).

### Opportunities and challenges

#### Cost

For HDVs using CNG or LNG, the annual mileage can be high enough such that fuel cost savings can offset purchase premiums in 1.5-3 years. In addition, centralized fleets able to do nightly refueling with a time-fill compressor can take advantage of the lower fuel and infrastructure cost and ensure that NGVs do not compromise operational requirements. For example, refuse haulers are transitioning to CNG at a rapid pace.

While the general industry perspective is that trucks traveling less than 200-300 miles between fueling are better suited to CNG and longer distances are better suited to LNG, relative fuel price and the “weight-sensitivity” of the operation (whether fully or partially loaded) also influence the economics (BNEF 2014). CNG is about \$.90 less expensive than the diesel gallon equivalent (dge), and thus can be cost competitive for longer distances even when not technically better suited. Moreover, the weight-sensitive operations may need to compensate for using CNG or LNG by making additional trips – thus a greater discount rate relative to diesel is needed to make natural gas

cost competitive (BNEF 2014).

### **Efficiency**

NGVs are typically less efficient than the gasoline or diesel vehicles they replace. The added weight from fuel storage is one contributor to this shortcoming, but there are others stemming from the engine itself. For LDVs, natural gas is typically used in spark-ignited engines that are designed to perform optimally with gasoline. Higher efficiencies would require a redesign of the pistons and cylinders for higher compression ratios (thanks to higher octane performance) to achieve the same performance with natural gas (NRC 2013).

For HDVs, spark-ignited NGVs replace compression-ignited diesel vehicles. This efficiency deficit is more pronounced than for LDVs because compression-ignited engines can achieve higher compression ratios and higher thermal efficiencies. Westport recently unveiled a hybrid natural gas engine that is compression-ignited using small amounts of diesel fuel and achieves similar efficiencies as traditional diesel engines. Another source of efficiency loss for heavy-duty LNG vehicles is burnoff, essentially the evaporation of LNG that escapes the fuel tank. This is one reason LNG is best suited for long-haul trucks since many hours of continuous driving minimizes the burnoff losses per tank.

### **Safety**

The safety challenges in an NGV stem from the high-pressure storage of gas and/or the combustion risk of natural gas. Natural gas use for transportation benefits from decades of safe driving and operational experience. The greatest risk is the puncturing of a CNG tank during an accident. Since natural gas is lighter than air, it would dissipate quickly if it escaped from the storage tank, and the placement of the tank away from the engine keeps the fumes away from high-temperatures (natural gas ignition temperature is higher than gasoline) (NRC2013). Testing and the use of high-strength materials have made natural gas vehicles at least as safe as traditional gasoline and diesel vehicles. Thus, safety is not seen as a significant shortcoming of NGVs.

### **Environmental considerations**

The benefits of the lower emission profile of NGVs should not be understated for HDVs operating in controlled air quality districts. For instance, tight restrictions on pollutants at the Ports of Long Beach and Los Angeles in California compelled many Class 8 tractor-trailer operators to switch to NGVs (NPR 2012). However, while natural gas burns more cleanly and has lower tailpipe emissions relative to gasoline and diesel, analyses suggest methane leakage across the natural gas supply chain may mitigate these benefits (Alvarez 2012). The extent of these leaks is somewhat uncertain, and recent evidence suggests that the quantity could be significant (Brandt 2014). Methane released into the atmosphere oxidizes with OH radicals to form water vapor, which has a high heat capacity, and can therefore contribute significantly to global warming (IPCC 2013). While CO<sub>2</sub> can contribute to global warming for hundreds or thousands of years after it is released, the expected residence time of methane in the atmosphere is 12.4 years (IPCC 2013). However, the radiative forcing of methane during that time is so significant that over 20 years, methane is 84 times as potent as CO<sub>2</sub>, and 28 times as potent over 100 years (IPCC 2013).

### **References**

1. AEO 2014 – US Energy Information Administration. Annual Energy Outlook 2014 with projections to 2040. Washington, DC DOE/EIA-0383(2014), 2014.
2. Alvarez 2012 – Alvarez, R., Pacala, S.W., Winebrake, J.J., Chameides, W.L., Hamburg, S.P., 2012. “Greater focus needed on methane leakage from natural gas infrastructure,” Proceedings of the National Academy of Sciences 109 (17), 6435-6440.
3. ANL 2010 – Werpy, M.R., Santini, D., Burnham, A., Mintz, M, 2010. Natural Gas Vehicles: Status, Barriers, and Opportunities. Argonne, IL ANL/ESD/10-4.
4. BNEF 2014 – Bloomberg New Energy Finance. “Not all natural gas trucks are created equal: CNG vs. LNG fuel,” Gas Insight – Research Note, 4/2/2014.
5. Brandt 2014 – Brandt, A.R., Heath, G.A., Kort, E.A., O’Sullivan, R., Petron, G., Joraan, S.M.,

- Tans, P., Wilcox, J., Gopstein, A.M., Arent, D., Wofsy, S., Brown, N.J., Bradley, R., Stuckey, G.D., Eardley, D., Harriss, R., 2014. "Methane Leaks from North American Natural Gas Systems," *Science* 343, 733-735.
6. Cummins – Cummins Westport. "Find OEM" Accessed 7/28/2014. <http://www.cumminswestport.com/find-a-natural-gas-truck-or-bus>
  7. DOE AFDC – US Department of Energy. "Alternative Fuels Data Center," Accessed 7/28/2014. <http://www.afdc.energy.gov/>
  8. EPA 2014 – US Environmental Protection Agency. Inventory of U.S. Greenhouse Gas Emissions and Sinks: 1990–2012. Washington, DC EPA 430-R-14-003, 2014.
  9. IPCC 2013 – Intergovernmental Panel on Climate Change. Climate Change 2013: The Physical Science Basis. Contribution of Working Group I to the Fifth Assessment Report of the Intergovernmental Panel on Climate Change. Stocker, TF, D Qin, G-K Plattner, M Tignor, SK Allen, J Boschung, A Nauels, Y Xia, V Bex and PM Midgley (eds.). Cambridge University Press, Cambridge, UK and New York City, NY 2013.
  10. MIT 2011 – Massachusetts Institute of Technology. The future of natural gas. Moniz, EJ, HD Jacoby, AJ Meggs, (eds.). Cambridge, MA, 2011.
  11. NPC 2012 – National Petroleum Council. Advancing technology for America's transportation future. Washington, DC, 2012.
  12. NPR 2012 – Clark, K. "Cleaner Air in L.A. Ports Comes at a Cost to Truckers." National Public Radio. January 18, 2012. <http://www.npr.org/2012/01/18/145338359/cleaner-air-in-l-a-ports-comes-at-a-cost-to-truckers>
  13. NRC 2013 – National Research Council. Transitions to Alternative Vehicles and Fuels. The National Academies Press, Washington, DC 2013.
  14. Peterson 2014 – Peterson, M.B., Barter, G.E., West, T.H., Manley, D.K., 2014. "A parametric study of light-duty natural gas vehicle competitiveness in the United States through 2050." *Applied Energy* 125, 206–217.
  15. PGC 2013 – Potential Gas Committee. Potential Supply of Natural Gas in the United States. Golden, CO, December 31, 2012.
  16. TIAX-CNG – TIAX LLC. U.S. and Canadian Natural Gas Vehicle Market Analysis: Compressed Natural Gas Infrastructure. 2012. <http://anga.us/issues-and-policy/transportation/tiax-natural-gas-vehicle-market-analysis>
  17. TIAX-LNG – TIAX LLC. U.S. and Canadian Natural Gas Vehicle Market Analysis: Liquefied Natural Gas Infrastructure. 2012. <http://anga.us/issues-and-policy/transportation/tiax-natural-gas-vehicle-market-analysis>



## Part 2: Hydrogen Fuel Cell Vehicles

### Part 2: Hydrogen

1. *What is a hydrogen fuel cell vehicle, and why consider hydrogen for transportation?*
2. *Current state of technology and deployment*
  - Vehicles
  - Infrastructure and hydrogen production
3. *Opportunities and challenges*
  - Cost
  - Storage technologies
  - Durability
  - Safety
  - Environmental considerations
4. *References*

### What is a hydrogen fuel cell vehicle, and why consider hydrogen for transportation?

Hydrogen is one of the most abundant elements on earth. It is a gas, except at extremely cold temperatures (20K), and is colorless, odorless, tasteless, and nontoxic (NPC 2012). Hydrogen is not an intrinsic energy source but a secondary energy carrier similar to electricity (Ball 2009). Consequently, the advantages of using hydrogen as a fuel on security of supply or greenhouse gas emissions depend upon how the hydrogen is produced. Over 95% of hydrogen produced in the US is made from natural gas via steam methane reforming (NRC 2013). In this process, natural gas is broken down in a reaction with high temperature steam (steam reforming reaction) in the presence of a catalyst to produce a hydrogen-rich gas. A kilogram of hydrogen gas contains the energy equivalent of a gallon of gasoline.

A fuel cell is an electrochemical device that converts chemical energy from a fuel to electric energy with no combustion involved. The hydrogen fuel cell electric vehicle (FCEV) is an all-electric vehicle similar to a battery electric vehicle (BEV) except that the electric power comes from a fuel cell system with on-board hydrogen storage. Thus, the vehicle's power and amount of stored energy can be controlled separately rather than being tied to battery size (DOE AFDC). Polymer electrolyte membranes (PEMs) are the most common type of fuel cell for vehicles. FCEVs are commonly configured as hybrids in that they use a battery for capturing regenerative braking energy and for supplementing the fuel cell output as needed (NRC 2013). The fuel cell system consists of a fuel cell stack and supporting hardware. The fuel cell stack operates like a battery pack with the anodes fueled by hydrogen gas and the cathodes fueled by oxygen from the air (NRC 2013). Hydrogen is broken into protons and electrons through an electrochemical reaction in the fuel cell catalyst, and protons travel through the membrane to the cathode (DOE AFDC). FCEVs are fueled with hydrogen at a fueling station, much like gasoline fueling, and hydrogen is stored on the vehicle at high pressures as a compressed gas.

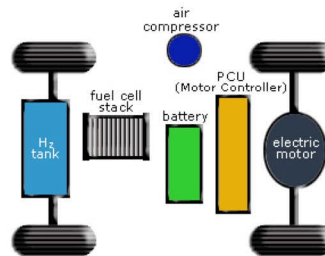

*Fuel cell vehicle schematic. Image from DOE Alternative Fuels Data Center (Source: NREL)  
[http://www.afdc.energy.gov/vehicles/fuel\\_cell.html](http://www.afdc.energy.gov/vehicles/fuel_cell.html)*

Hydrogen could be used directly in an internal combustion engine, instead of a fuel cell, but would then offer no efficiency benefit over traditional gasoline engines. Alternatively, other fuel cell types exist which do not require hydrogen as fuel, and thus fuel cells could enter the market independently of hydrogen production or infrastructure development. However, fuel cells powered by hydrogen have the highest conversion efficiency and thus are viewed as making the most sense for transportation applications (Ball 2009). Moreover, the byproduct of a fuel cell is just water, so there are no tailpipe emissions stemming from vehicle operation.

The attractiveness of FCEVs is similar to the benefits of BEVs. FCEVs offer zero tailpipe emissions, an alternative to petroleum, and a pathway to renewable and sustainable transportation. By using an electric drive, FCEVs offer excellent acceleration, constant torque availability, quiet operation, and low levels of vibration. Both BEVs and FCEVs could be renewably fueled, depending on the electricity or hydrogen production feedstock. However, unlike BEVs which are generally limited by battery range to small vehicles, FCEVs generally have driving ranges comparable to ICEs and are

Prepared by Garrett Barter,  
Dawn Manley, Todd West



scalable to all vehicle sizes. Moreover, refueling time is similar to that of gasoline vehicles and the refueling experience is also cleaner than the traditional gasoline experience (no vapors, drips or smells) (NPC 2012). BEVs require longer charge times or incomplete recharging. Full recharges require several hours, and existing direct current fast charging technologies can provide 80% charge in less than 30 minutes.

### **Current state of technology and deployment**

#### ***Vehicles***

Fuel cell stacks currently used in automotive applications use a proton exchange membrane with precious metal (primarily platinum) catalysts to promote the hydrogen-oxygen reaction (NRC 2013). Today, the efficiency of the fuel cell system for passenger cars is around twice that of a gasoline internal combustion engine (Ball 2009). Compressed gas at 5,000 psi (35 MPa) or 10,000 psi (70 MPa) has emerged as the primary technology path for the introduction of FCEVs (Jorgensen 2011). Hyundai recently became the first automaker to commercially release a FCEV. The Tucson Fuel Cell has a driving range of up to 265 miles and is offered for a 36-month lease at \$499/month (\$2,999 at signing), including fuel and maintenance (Hyundai). Several other companies (e.g. Daimler, Honda, and Toyota) have announced plans to introduce FCEVs commercially starting in 2015, but mainly in regions where governments are coordinating efforts to build hydrogen infrastructures (NRC 2013). Both the Honda Clarity and Toyota Highlander FCEV demonstration vehicles have achieved on-road efficiencies greater than 60 mpgge (Honda, Toyota).

According to the 2013 DOE Fuel Cell Technology Office program accomplishments (DOE-FCTO-Accomp2013), over 180 demonstration FCEVs have been in operation with a typical range of 250 miles and up to 430 miles of range. They have demonstrated 2,500 hours (75,000 miles) of durability in real world conditions. This is relative to 950 hours of durability reported for 2006. DOE/FCTO also reports that there have been advances in manufacturing methods and materials that have reduced the cost of gas diffusion layers in particular by 50% since 2008, and overall cost reductions of over 35% in a similar time frame. The “cost of an 80-kW<sub>net</sub> polymer electrolyte membrane (PEM) fuel cell system based on 2013 technology and operating on direct hydrogen is projected to be \$67/kW when manufactured at a volume of 100,000 units/year, and \$55/kW at 500,000 units/year” (DOE-FCTO-Record13012). To put these volumes in perspective, the top-selling light duty vehicle in the US, the Ford F-Series, recorded 763,402 units sold in 2013 (CarSales 2013).

Water is the byproduct of the chemical reaction in the fuel cell stack, and water product that remains in the stack will freeze during cold parking. For early FCEVs, this meant that in cold weather operation, the stack had difficulty starting and freezing damage could rapidly degrade the stack (NPC 2012). FCEVs use a small battery for both regenerative braking and cold start operation (NRC 2013). FCEVs deployed in cold weather regions have validated this progress, and they have performed through several winters of demonstration and validation testing (NPC 2012, Wipke 2012). FCEVs nevertheless still require up to 60 seconds for full fuel cell power availability in extreme cold.

#### **Infrastructure and hydrogen production**

Hydrogen, as an industrial commodity in the US, is produced at a rate of 10 million tons per year for chemical processing and refining crude oil in large facilities closely associated with the end use (NRC 2013). There is currently little excess capacity to devote to transportation. If all of the hydrogen were to be used as a transportation fuel, then this current production level would be enough to fuel only one-sixth of the light-duty vehicle stock (45 million cars at 60 mpgge and 12,000 mi/yr) (NRC 2013).

In the US, there are 12 hydrogen stations currently registered with DOE (not including private installations), and California has announced plans to build 25 more to support the deployment of FCEVs (DOE AFDC). The United Kingdom, Japan, Germany, and South Korea have signaled their intentions to move towards commercial introduction of hydrogen fueled vehicles and infrastructure in the near future, with government providing coordination and funding support for early movers in industry (NPC 2012, UK 2014). These developments are motivated by environmental, economic, and energy security concerns. For example, the UK H2Mobility program sites four potential benefits for hydrogen vehicles: 1) decarbonizing road transport to support an overall goal of 80% reduction of

carbon emissions by 2050; 2) creating new economic opportunities; 3) diversifying energy supplies; and 4) reducing local environmental impacts (UKH2Mobility 2014).

Until a large number of FCEVs are in use, the cost of hydrogen as a fuel will be high due to upfront infrastructure costs. Current estimates for pump prices of hydrogen are \$3.50-\$6 per gge (NRC 2013), depending on hydrogen production method. However, these costs assume high-volume production to support 10 million FCEVs. Initial hydrogen costs could be as much as \$9-\$12/gge, more closely reflecting the cost of using centralized industrial hydrogen production for transportation needs (NPC 2012). The current production supports large quantities of hydrogen delivery to a few users, instead of the small quantities distributed to many dispersed users that would be needed for transportation.

There are two paradigms for hydrogen infrastructure to support FCEVs. The first paradigm involves the centralized production of hydrogen at a dedicated facility and distribution to refueling stations. Centralized production, while costly, represents how hydrogen is produced today for industrial applications and thus would be easiest to transition to a fledgling transportation infrastructure (NRC 2013). The second paradigm involves the distributed production of hydrogen at the refueling locations. There is some disagreement in the literature about which paradigm is best suited for nascent infrastructure. The National Academies and National Petroleum Council both suggest centralized production will be used initially and then gradually transition to distributed production. Large hydrogen production facilities exist in most states and some excess capacity exists that could be dedicated to transportation (NPC 2012). Ball and Wietschel argue the opposite since distributed production can be better sized for low demand conditions and can be more rapidly constructed to support new opportunities (Ball 2009).

After production at a large centralized facility, hydrogen can be compressed and distributed in gaseous state through pipelines, distributed in gaseous state by truck, or liquefied by cooling and delivered by truck. Pipelines have the lowest operational cost, but have a steep capital cost that is exacerbated by the need to use non-porous stainless steel to avoid hydrogen embrittlement of standard metals (Ball 2009). Thus, dedicated hydrogen pipeline infrastructure is unlikely until market conditions make it economical. Liquefaction, while achieving a much higher volumetric energy density, is also costly and involves greater losses in the hydrogen production pathway. About 40% of the energy contained in hydrogen is necessary for liquefaction (Edwards 2008). Since hydrogen is stored on the vehicle in gaseous form, this is the anticipated state of distribution as well. On-road hydrogen deliveries are traditionally made by tankers that carry up to 250 kg of gaseous hydrogen at 2,500 psi in steel cylinders and are made at \$1.25-\$2.25 per kg (NPC 2012). Distribution technologies introduced in 2010 increase capacity per truck (up to 1,000 kg) and allow for storage at pressures at or above the pressure needed at the refueling locations (up to 7,250 psi), thereby alleviating on-site compression needs and reducing cost. However, frequent delivery to a retail fueling location adds logistical complexity and is generally perceived as costlier in the near term (NPC 2012), but may scale more readily to support higher hydrogen demand (Ball 2009).

In the distributed paradigm, a small-scale hydrogen production unit would be deployed at a refueling facility. Steam methane reforming (SMR) and water electrolysis have both been successfully demonstrated in real world settings for fueling applications. However, compression of hydrogen to 5,000 to 10,000 psi following production presents land, maintenance, and capital challenges. A typical hydrogen compression system for fueling requires ~100 ft<sup>2</sup> of space at a fueling station and should be located where equipment noise is either not a concern or can be buffered. The cost of a compression system can range from 20 to 50% of the total cost of the fueling station (NPC 2012). Supporting the 10,000 psi FCEVs versus the 5,000 psi FCEVs could mean higher fuel costs due to the additional investment in compressor size, storage tank ratings, and pressure cascades. Additionally, the reliability of high-pressure hydrogen compressors at fueling locations has to date been inadequate for commercial applications (NPC 2012).

Regardless of the production paradigm, hydrogen must be stored at refueling locations at high



pressure. This is typically done with a cascade of high pressure steel tubes on concrete slabs. Based on demonstration hydrogen stations built to date, a traditional steel tube storage system with 300 kg storage capacity occupies  $\sim 450 \text{ ft}^2$ , not including setback requirements.

### **Opportunities and challenges**

#### **Cost**

Meeting range, longevity, and fuel cell efficiency targets has been shown to be technically feasible, but the costs of FCEVs are still far from being cost-competitive with conventional internal combustion engine vehicles. Estimates of MSRP for the 2015 commercially available FCEVs are approximately \$35k-\$50k (NPC 2012, CR 2014). The cost stems primarily from the use of platinum catalysts and the carbon-fiber storage tanks. Since 2002, fuel cell system cost reductions of 80% have been realized (NPC 2012). The cost for platinum catalyst has declined from approximately \$2500 in 2005 to \$600 in 2011, based on mass reduction alone (NRC 2013). Current estimates of storage costs are \$628/kg (NRC 2013). Addressing the research challenges in hydrogen storage, the use of platinum as a catalyst, and manufacturing complexity would reduce the cost to FCEV consumers.

#### **Storage technologies**

The compressed gas storage capacity, and hence the vehicle driving range, is limited by the volume and cost of tanks that can be packaged in vehicles. While hydrogen has a high energy density by mass, it has poor volumetric energy density. To achieve driving ranges over 300 miles, carbon-fiber reinforced composite tanks are used to balance sufficient strength versus manageable weight (NRC 2013). Improving the storage density of hydrogen at lower cost is an active area of research, with several early stage options. Toyota is actively exploring optimized fiber direction and winding patterns (Toyota). Others are focusing on storage of high pressure gas in capillaries or microspheres and storage of hydrogen in hydrides, as well as more exotic ideas such as reactive chemicals (Jorgensen 2011).

#### **Durability**

Increased longevity of fuel cell stacks is needed for commercial success. The electrolyte membrane is sensitive to stress, harmful chemical exposure, or high-current hot spots. Membrane failure plagued early FCEVs, but improvements have been demonstrated and catastrophic failures have not been observed in the latest demonstration efforts (NPC 2012, Wipke 2012). Durability research now focuses on minimizing stack degradation. The fuel cell stack, like batteries and all other electrochemical systems, is subject to degradation over usage cycles and calendar life. The goal is not to eliminate this degradation, but rather to slow its rate such that power loss over 5,000 hours (150,000 miles of operation) does not impact the ability of the vehicle to meet its performance targets (NPC 2012). This is consistent with the approach currently used to manage conventional vehicle performance degradation.

#### **Safety**

The safety challenges for FCEVs and at refueling stations stem from high voltage electrical equipment, high pressure gas storage, and the combustion risk of hydrogen. The safety of high voltage electric power is managed on FCEVs similarly to EVs, where safety requirements have resulted in on-road safety statistics comparable to that of traditional internal combustion vehicles [NRC2013]. The long history of use of hydrogen in industrial applications has been leveraged for developing safe-handling procedures. The safety of high-pressure onboard gaseous fuel storage has been demonstrated worldwide in decades of use in natural gas vehicles. Comparable safety criteria and engineering standards have been applied to FCEVs, with adaptation of safety provisions for differences between properties of natural gas and hydrogen (NRC 2013). While fire risk is somewhat mitigated because hydrogen dissipates much faster than gasoline fumes (due to its low density), hydrogen is far more easily ignited than natural gas or gasoline and burns with a flame that is nearly invisible in daylight (NPC 2012). Developing safety standards and codes for infrastructure construction is still a work in progress.

### **Environmental considerations**

For hydrogen produced via steam methane reforming, the final products are hydrogen and CO<sub>2</sub>, which is typically released into the atmosphere. This could be countered by using carbon capture and sequestration (CCS) or bio-methane feedstocks instead of natural gas. The efficiency of SMR is 70-80%, but can be as high as 90% at large production facilities. Efficiency falls rapidly at partial loading (NPC 2012). Nevertheless, the per-mile, well-to-wheel GHG footprint of FCEVs is approximately 50% lower, when using natural gas as the feedstock, than that of a today's conventional gasoline vehicle (NPC 2012).

Hydrogen produced by water electrolysis uses electricity to split water molecules into oxygen and hydrogen. Electrolysis typically has a lower efficiency than SMR (55-75%), but unlike SMR, efficiency is best at low output levels (NPC 2012, Edwards 2008). While water electrolysis is the more expensive alternative (leading to pump prices of \$5.80/kg for electrolysis versus \$3.80/kg for SMR) (NRC 2013), electrolysis plants are compact, operate at low temperatures, and produce no local CO<sub>2</sub> (NPC 2012). Renewable sources of electricity would lead to completely CO<sub>2</sub> free production pathways. From an efficiency point of view, use of electrolysis-generated hydrogen in FCEVs is at a disadvantage compared to BEVs due to energy losses in generating hydrogen from electricity, compressing it, transporting it, storing it, and processing it through the fuel cell to recover the electricity again on the vehicle.

Increased adoption of FCEVs can contribute to substantial reductions in urban pollution from soot, NO<sub>x</sub>, and SO<sub>x</sub>. However, the likely leakage rate of hydrogen and the subsequent consequences are somewhat uncertain. Just as methane leakage rates from natural gas operation are an active area of debate, hydrogen leakage rates are also difficult to ascertain. Hydrogen is a trace atmospheric constituent (0.5ppm by volume) and its level is primarily determined by photochemical reactions in the atmosphere and uptake in the soil (Tromp 2003). Thus, human activity for promoting hydrogen for transportation may be a notable contributor to atmospheric levels. Increasing the source of hydrogen to the atmosphere may moisten and cool the stratosphere. Modeling results show that colder temperatures would create more polar stratospheric clouds, delay the breaking up of the polar vortex, and thereby make the ozone hole deeper, larger (in area), and more persistent (in spring) (Tromp 2003). Atmospheric hydrogen oxidation could also disturb ozone chemistry.

### **References**

1. Ball 2009 – Ball, M. & Wietschel M., 2009. "The future of hydrogen – opportunities and challenges," *International Journal of Hydrogen Energy*, 34 (2), pp. 615–627.
2. CarSales 2013 – <http://blogs.cars.com/kickingtires/2014/01/the-top-10-best-selling-cars-of-2013.html>. Accessed June 2014.
3. CR 2014 – Shenhar, G. "Toyota's fuel-cell car gains ground on hybrids" *ConsumerReports.org*, February 24, 2014.
4. DOE-FCTO-Accomp2013 – DOE Fuel Cell Technology Office. Progress and Accomplishments in Hydrogen and Fuel Cells. March 2013.
5. DOE-FCTO-Record13012 – DOE Fuel Cell Technology Office Record #13012. "Fuel Cell System Cost – 2013." October 16, 2013.
6. Edwards 2008 – Edwards, P.P. & Kuznetsov, V.L. & David, W.I.F. & Brandon, N.P., 2008. "Hydrogen and fuel cells: Towards a sustainable energy future," *Energy Policy*, 36 (12), 4356-4362.
7. Honda – Honda FCX Clarity Overview, <http://automobiles.honda.com/fcx-clarity/>. Accessed May 2014.
8. Hyundai – Hyundai USA Tucson Fuel Cell, <http://www.hyundaiusa.com/tucsonfuelcell/>. Accessed July 2014.
9. Jorgensen 2011 – Jorgensen, S.W., 2011. "Hydrogen storage tanks for vehicles: Recent progress and current status," *Current Opinion in Solid State and Materials Science*, 15 (2), 39-43.
10. NPC 2012 – National Petroleum Council. Advancing technology for America's



- transportation future. Washington, DC, 2012.
11. NRC 2013 – National Research Council. Transitions to Alternative Vehicles and Fuels. Washington, DC: The National Academies Press, 2013.
  12. Toyota – Toyota Fuel Cell Cars, <http://www.toyota.com/fuelcell/>. Accessed May 2014.
  13. Tromp 2003 – Tromp, T.K., Shia, R., Allen, M., Eiler, J.M., Yung, Y.L., 2003. “Potential Environmental Impact of a Hydrogen Economy on the Stratosphere” *Science* 13, 300 (5626), 1740-1742.
  14. UK 2014 – Office for Low Emission Vehicles, “Investing in ultra low emission vehicles in the UK, 2015 to 2020.” April 2014.
  15. UKH2Mobility 2014 – UK H2 Mobility “Phase 1 Results,” April 2013, Page 3.
  16. Wipke 2012 – Wipke, K., Sprik, S., Kurtz, J., Ramsden, T., Ainscough, C., Saur, G. “Final Results from U.S. FCEV Learning Demonstration Preprint.” EVS26 International Battery, Hybrid and Fuel Cell Electric Vehicle Symposium. May, 2012.



# TRANSITIONING THE TRANSPORTATION SECTOR: Exploring the Intersection of Hydrogen Fuel Cell and Natural Gas Vehicles

*September 9, 2014*

Sandia National Laboratories is a multi-program laboratory managed and operated by Sandia Corporation, a wholly owned subsidiary of Lockheed Martin Corporation, for the U.S. Department of Energy's National Nuclear Security Administration under contract DE-AC04-94AL85000. SAND No. 2015-0437



**Sandia National Laboratories**