

EV

everywhere

GRAND CHALLENGE



road to
success



january 2014

A MESSAGE FROM THE **assistant secretary**

Through the *EV Everywhere Grand Challenge*, U.S. researchers, employers, and PEV owners are all contributing to the growth of the clean energy economy.



Dr. David T. Danielson
Assistant Secretary for
Energy Efficiency and
Renewable Energy

One year ago, we shared with you the *EV Everywhere Grand Challenge* Blueprint, providing a strategy to enable plug-in electric vehicles (PEVs) that are as affordable and convenient for the American family as gasoline-powered vehicles by 2022. The Department of Energy (DOE) is committed to making the investments necessary to get us there.

In this initial progress report for *EV Everywhere*, we are pleased to tell you that these investments are paying off. With DOE support, we have seen significant cost reduction in batteries this year, which will enable increased PEV affordability for consumers. We have also focused our efforts on increasing the convenience of PEVs through the Workplace Charging Challenge, which calls on U.S. employers to help develop the nation's charging infrastructure.

The momentum is building as consumers are embracing PEVs in the market. Total U.S. PEV sales in model year 2013 nearly doubled those of 2012, approaching 100,000 sold for the year alone. Additionally, nearly 10,000 plug-in vehicles were sold in December 2013, up 28% over the sales in December 2012.

Sustained growth in consumer adoption of PEVs will require further technology developments, cost reductions, and the expansion of the nation's PEV charging infrastructure. Through the collaborative efforts of the Federal government, automotive industry, national laboratories, and universities, I am confident that we can continue to achieve the necessary technical advances. Similarly, the deployment of charging infrastructure and consumer PEV education relies on the collaboration of states, communities, nongovernmental organizations, and individual citizens. We have seen tremendous efforts on all of these fronts in 2013, and look forward to further growth through these and other partnerships.

EV Everywhere is changing how Americans drive and consume energy. I invite you to learn more about *EV Everywhere's* achievements as we move towards clean and affordable transportation for all.

Dr. David T. Danielson

Assistant Secretary for Energy Efficiency and Renewable Energy
U.S. Department of Energy

EV EVERYWHERE – EARLY SUCCESSES

The top four things you need to know

- ▶ DOE research and development has reduced the cost of electric drive vehicle batteries to \$325/kWhr, 50% lower than just four years ago.
- ▶ In the first year of the Workplace Charging Challenge, more than 50 U.S. employers joined the Challenge and pledged to provide charging access at more than 150 sites.
- ▶ DOE investments in *EV Everywhere* technology topped \$225 million in the last 12 months, addressing key barriers to achieving the Grand Challenge.
- ▶ Consumer acceptance is rapidly growing – 97,000 plug-in electric vehicles were sold in 2013, nearly doubling 2012 sales.

ELECTRIC VEHICLES

the state of the industry

EV Everywhere has set a goal for the U.S. automotive industry to produce plug-in electric vehicles (PEVs) that will be as affordable and convenient as gasoline-powered vehicles by 2022. Technology innovation towards this goal will come from the research and development (R&D) work of partners from the national laboratories, industry, and universities. Getting today's PEVs onto the nation's roads and into the hands of eager drivers will also require ongoing efforts of state and local governments in partnership with industry to deploy the charging infrastructure for these vehicles and educate the public about them.

The early market for PEVs continues to grow. PEVs reached 100,000 cumulative sales in May 2013, and

are on track to pass the 200,000 sales milestone by spring 2014, about 40 months after the introduction of the production models of the Chevrolet Volt and Nissan Leaf. By comparison, hybrid electric vehicles (HEVs) took 60 months to achieve 200,000 total sales nearly a decade ago.

Why are PEVs selling so quickly?

One major reason is that drivers have a wide variety of PEV options to choose from. Fifteen PEV models were available during the 2013 model year, and eight more plug-in cars and SUVs are being launched for the 2014 model year. Today a PEV driver can choose from a variety of PEVs, ranging from a plug-in hybrid mid-size sedan with a 15-mile all-electric range to a full-size liftback EV that can travel up to

265 miles on a single battery charge. Incentives and price reductions have also made PEVs more attractive to many consumers.

Drivers and critics alike continue to praise PEVs for their performance and value. Notable awards and mentions include:

- ▶ PEVs have topped the Consumer Reports owner satisfaction survey for the last three years: the Chevrolet Volt in 2011 and 2012, and the Tesla Model S in 2013, with a score of 99 out of 100 total points.
- ▶ The *Kelley Blue Book* 5-Year Cost to Own Awards ranked the 2013 Chevrolet Volt as #6 in its list of vehicles that have the lowest total cost of ownership for five years after

“ More and more Americans are taking advantage of the low and stable price of electricity as a transportation fuel, and that's very good news for our economy as well as the environment. As the market continues to grow, electric vehicles will play a key role in our effort to reduce air pollution and slow the effects of climate change. ”

– Secretary of Energy Dr. Ernest Moniz, U.S. DOE, July 2013

the purchase of a new car. Only compact and subcompact cars cost less over this period.

- ▶ The Tesla Model S received numerous accolades during 2013, including the World Green Car of the Year, and Car of the Year by both *Motor Trend* and *Automobile Magazine*.
- ▶ The 2014 Honda Accord, which includes a plug-in hybrid EV (PHEV) model, won the 2014 Green Car of the Year Award at the Los Angeles Auto Show.

PEVs have also begun to thrive in certain niches that align with their strengths, such as carsharing and other fleets. Carsharing organizations offering urban dwellers short-term rentals of vehicles parked in their neighborhoods are located in many cities across the U.S. The vehicles in the carsharing fleets generally do not travel far, and many organizations have explicit environmental goals of reducing fuel consumption and emissions. Currently, car2go in San Diego, California, has a fleet of all-electric vehicles, and City Carshare, a not-for-profit carsharing organization in San Francisco, California, has put together an extensive fleet which is more than 50% PEVs and HEVs.

The national carsharing company Zipcar has also piloted PEVs in fleets in some of its larger urban locations, such as Chicago, Illinois. Taxi fleets in New York City and Portland, Oregon, have been running pilot programs for PEVs to explore their feasibility for use during the typical 12-hour shifts.

EV Everywhere consists of three main elements: 1) a technology push of research and development to reduce the cost of PEVs, 2) charging infrastructure development to enable the convenience of fueling PEVs, and 3) activities to help consumer acceptance of PEVs and create a market pull.

New PEV sales compared to HEV sales over their respective 36-month introductory periods

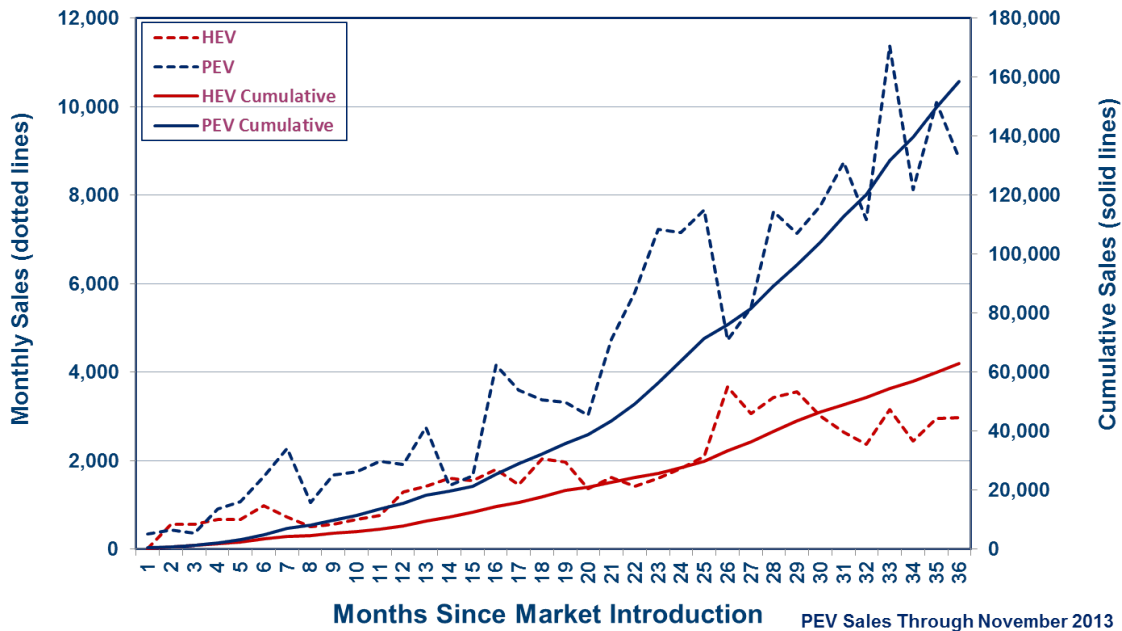

PEV sales 12/2010 through 11/2013, HEV sales 12/1999 through 11/2002

¹ <http://www.kbb.com/car-reviews-and-news/top-10/5-year-cost-to-own-awards-2013/2000009033-6/>, retrieved 12/9/2013; also <http://www.chevrolet.com/culture/article/5-year-cost-to-own-awards.html>, retrieved 12/9/2013.

PROGRESS IN technology

EV Everywhere's technology push focuses on cost reductions and performance improvements in the platform technology areas of batteries,

electric drive systems including power electronics and electric motors, lightweight materials, efficient climate control, and PEV charging. During

2013, research and development programs in each of these areas demonstrated progress towards the *EV Everywhere* goals.

BATTERIES

***EV Everywhere* battery goals for 2022: \$125/kWh cost, 400 Wh/liter energy density, 250 Wh/kg specific energy, and 2000 W/kg specific power**

DOE R&D has reduced the cost of PEV batteries by approximately 50% over the last four years. The

modeled cost of PHEV batteries under development has been lowered from over \$625/kWh in 2010, to the current cost of \$325/kWh of useable energy. Battery developers working with the United States Advanced Battery Consortium (USABC) have made significant advances in cost

reduction using advanced cathodes, processing improvements, lower-cost cell designs, and pack optimization. Concurrently, the size and weight of PEV batteries have also been reduced by over 60%. Battery energy density has increased from 60 Wh/liter in 2008, to 150 Wh/liter in 2013.

Modeled cost and energy density of PHEV batteries developed and tested

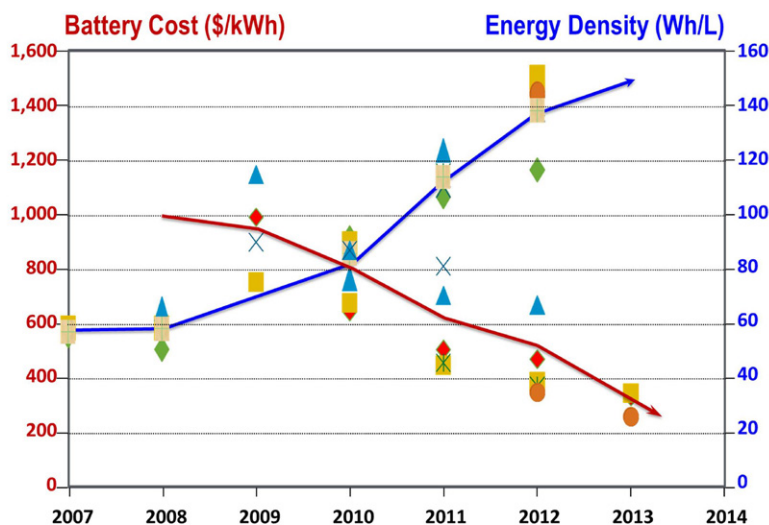

Battery manufacturers derived the cost projections using USABC's battery manufacturing cost model based on a production volume of 100,000 batteries per year for validated battery cell and module designs that meet DOE and USABC requirements for power, energy, and cycle life.

Why have EVs Everywhere?

- ▶ To reduce U.S. dependence on imported oil and increase national energy security
- ▶ To save money by cutting fuel costs for American families and businesses
- ▶ To protect our health and safety by mitigating the impact of energy production and use on climate change
- ▶ To spur innovation to build U.S. industry and jobs

Despite the progress achieved to date, *EV Everywhere* still has challenging battery goals to accomplish (i.e., \$125/kWh, 400 Wh/liter, 250 Wh/kg, and 2000 W/kg in 2022). Battery developers so far have used standard electrolytes and graphite anodes. The potential of more advanced lithium-ion materials and “beyond lithium-ion” chemistries to reach these goals has been quantified using the Battery Performance and Cost (BatPaC) model developed at Argonne National Laboratory (ANL). This model captures the interplay between design, performance, and cost of advanced

battery technology. The results show that the combination of lithium- and manganese-rich high-energy cathode (LMRNMC) and silicon alloy anodes can meet the *EV Everywhere* cost goals, as well as lithium metal battery technology. Batteries with silicon alloy anodes (Si/LMRNMC) and lithium metal batteries (Li/LMRNMC) are estimated to be able to meet the \$125/kWh target cost.

However, a number of technical hurdles remain to achieve practical PEV battery systems with these advanced battery technologies,

including cycle life, power, and low-temperature operation. In 2013, the DOE Vehicle Technologies Office (VTO) launched six new projects with a total of \$20 million in funding to further develop batteries using advanced silicon alloy anodes and high-energy cathodes. In addition, VTO is partnering with the DOE Office of Science and ARPA-E to further the development of lithium metal batteries.

Estimated cost for PEV battery at volume production

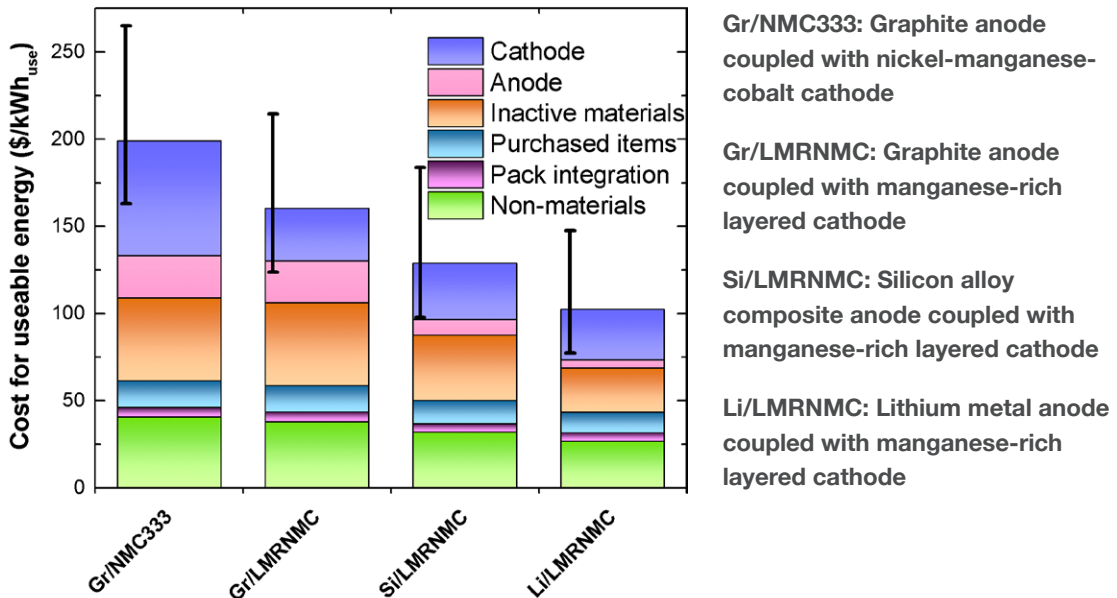

Estimated cost for a 100 kWh_{use} PEV battery using advanced technology and produced at 100,000 packs per year. (Courtesy of Argonne National Laboratory, Joint Center for Energy Storage Research, supported by the DOE Office of Science, Basic Energy Sciences.)

“ The era of using electricity to help improve performance and fuel economy is already here and the trend is only going to grow. In fact, we expect to have an estimated 500,000 vehicles on the road with some form of electrification by 2017. ”

– Dan Akerson, former CEO of General Motors, speech at the IHS Energy CERAWEEK conference, March 2013

ELECTRIC DRIVE SYSTEMS

EV Everywhere electric drive system goals for 2022: \$8/kW cost, 1.4 kW/kg specific power, 4.0 kW/L power density, and 94% system efficiency, meaning a 55-kW system cost of \$440

In 2013, Delphi Automotive Systems and DOE worked on a high-temperature inverter research and development project that achieved the 2015 DOE \$5/kW cost target and exceeded 2015 component targets for specific power and power density. Delphi is incorporating the technology innovations developed during this project such as low-loss semiconductors and packaging, thermal materials, and inverter design concepts into an inverter planned for production in mid-2015.

This inverter design is also scalable across a wide power range which can meet the needs of different PEVs, and is capable of operating at high temperature, using a standard 105°C engine coolant system. The separate cooling loop typically required for inverters can then be

eliminated, which could lead to additional cost, weight, and volume savings for PEVs.

Two related development projects led to improved capacitors for vehicle power electronics. The Delphi inverter's higher temperature capability largely depended on a dc-link capacitor developed by General Electric that uses a novel film that is capable of 200°C operation versus the 85°C upper limit for these devices today. Delphi also teamed with ANL to develop a more durable capacitor based on a second novel material. The team has identified potentially low-cost fabrication processes for producing a high-temperature-capable capacitor potentially 90% smaller than today's dc-link capacitor.



Delphi met or exceeded DOE targets in the inverter shown. (Courtesy of Delphi Automotive Systems.)

Metrics	DOE Specified	Delphi Achievement
Cost	\$5/kW	\$5/kW
Specific Power	12 kW/kg	17 kW/kg
Power Density	12 kW/L	15 kW/L

VEHICLE LIGHTWEIGHTING

EV Everywhere materials lightweighting goals for 2022: overall weight reduction goal of almost 30%, which comprises a 35% reduction of the body structure weight, 25% reduction of the chassis and suspension weight, and 5% reduction of the interior weight

In 2013, DOE supported the Automotive Composites Consortium underbody project, which designed, built, analyzed, and tested an automotive lightweight composite underbody capable of carrying the crash loads of a vehicle, while saving about 13 kg mass compared to the optimized high strength steel underbody in the donor vehicle. Minimizing the mass of this structure was a complex task requiring a number of thickness zones in the part, ranging from 1.8 mm to 5.4 mm, which allowed structural strength to be optimized where it was needed. The Chevrolet Spark EV team applied this technology as a solution for the two-piece structural battery enclosure in a very short time from start of production.

Additionally in 2013, researchers made significant progress in introducing new materials to the vehicle structure. The capability to join dissimilar materials is key to meeting *EV Everywhere* weight reduction goals. Project tasks focused on joining magnesium-intensive substructures to incorporate and interface with steel and aluminum, demonstrating successful aluminum-magnesium joints. The state-of-the-art automotive manufacturing techniques of friction stir welding (upper rail) and self-piercing rivets (lower rail) were used to make these joints.

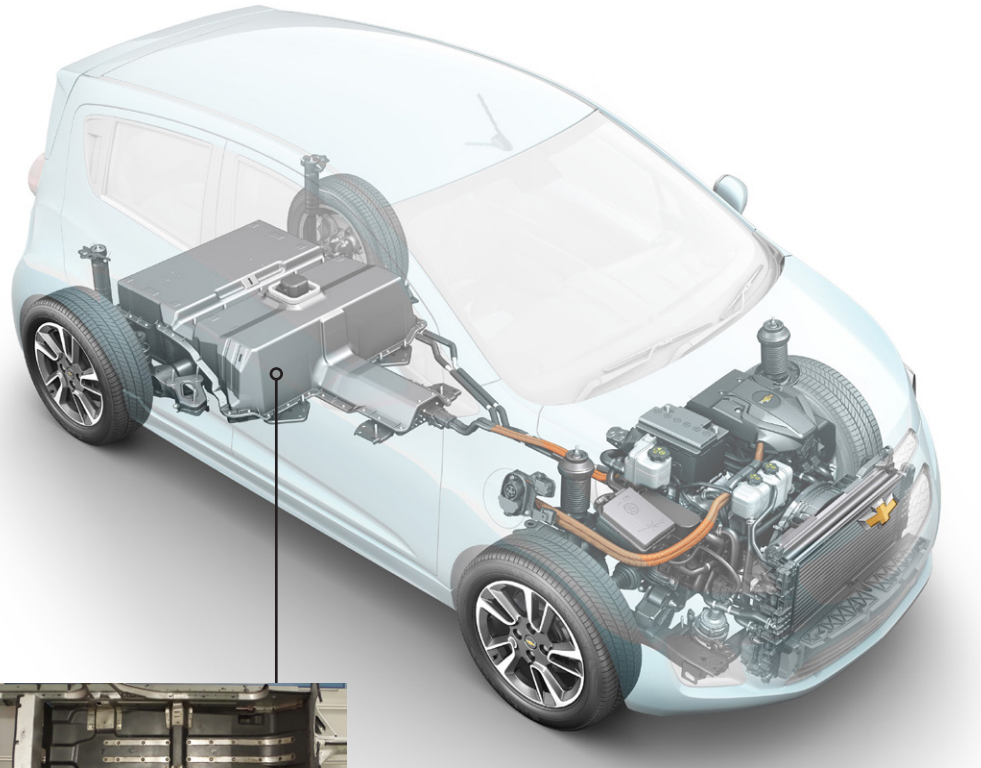

The Automotive Composites Consortium Structural Composite Underbody project led to the rapid commercialization of the Chevrolet Spark EV battery enclosure. (Courtesy of General Motors and the National Renewable Energy Laboratory.)

Demonstration “front-end” structure using multmaterial joining techniques as indicated. (Courtesy of the United States Automotive Materials Partnership, Magnesium Front-End Research and Development project.)

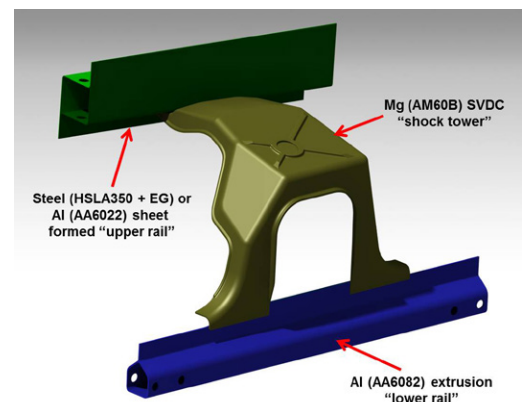

Multimaterial solutions like these large, lightweight, magnesium alloy subassemblies are capable of significantly contributing to meeting the *EV Everywhere* overall weight reduction goal of almost 30%.

EFFICIENT CLIMATE CONTROL TECHNOLOGIES

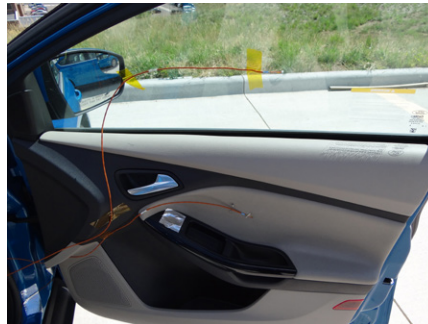

Thermal testing instrumentation for the zonal climate control system incorporated over 40 calibrated thermocouples for interior and exterior temperature measurements on a Ford Focus electric vehicle. (Courtesy of National Renewable Energy Laboratory.)

Climate control systems can have a significant impact on PEV range. Recently, testing completed at the National Renewable Energy Laboratory (NREL) demonstrated that zonal climate control can reduce air conditioning needs and improve vehicle range while maintaining driver comfort. In cooperation with Ford Motor Company, NREL performed detailed, instrumented tests on Ford Focus electric vehicles. New approaches to vehicle interior heating, ventilation, and air conditioning (HVAC) demonstrated a 16.7% reduction in climate control energy compared to a baseline HVAC system. Furthermore, vehicle simulation over various test cycles showed a potential 7% to 15% increase in vehicle range achievable during air conditioner operation.

“The electric vehicle industry continues to grow year over year and is an integral part of the alternative energy vehicle industry. We know from our own experience that our market share is stronger than ever and sales are growing at a double-digit rate.”

– Pat Romano, CEO of ChargePoint, interviewed for *Silicon Valley Business Journal*, August 2013

CHARGING INFRASTRUCTURE

In addition to technology improvements and cost reductions on the PEV itself, DOE is also accelerating the development and deployment of cost-effective, consumer-friendly PEV charging options.

The emerging PEV charging technology of wireless power transfer (WPT) involves transferring power from the electric grid to a PEV's battery without the use of wires, cords, or plugs. WPT has the potential to greatly increase the convenience of PEV charging so that drivers more readily take advantage of every available opportunity to charge their vehicle. Since launching *EV Everywhere*, DOE has initiated projects to develop WPT solutions, integrate them into commercially available PEVs, and demonstrate the technology in the real world.

These projects involve the development of a grid-side WPT transmitting coil, a receiving coil mounted on the vehicle's underbody, and the electronics and communications hardware to enable highly efficient and safe power transfer to the vehicle's battery. As of late 2013, WPT project partners have already demonstrated power transfer rates of 10 kW, greater than that of most commercially-available PEVs that only go up to 3.3 kW or 6.6 kW. These systems can transmit energy across a gap of up to 16 cm (more than 6 inches), tolerate coil misalignment up to 20%, and transfer power at high efficiency of greater than 85% from wall-outlet to PEV battery.

Creating codes and standards that cover the interface between PEVs and the electric grid is critical for enabling a consistent, consumer-friendly charging experience for PEV drivers.

For example, DOE supported the publication of SAE J1772™, the standard that describes the physical and electrical interface used by nearly all PEVs in North America. To foster global industry and government cooperation on electric vehicle charging protocols and standards, DOE established the EV-Smart Grid Interoperability Center at Argonne National Laboratory in 2013.

DOE continues to collect and analyze data from thousands of PEVs and charging stations deployed through the Recovery Act-funded Transportation Electrification Initiative. By the end of 2013, this initiative had deployed more than 18,000 EV charging points in residential, commercial, and public locations, supporting over 11,000 PEVs. This effort has revealed important information regarding how PEV drivers use their vehicles and use charging infrastructure, and has proven invaluable to stakeholders as they plan for the mass deployment of millions of PEVs in the coming years.



PEV wireless charging over transmitting plate.
(Courtesy of Oak Ridge National Laboratory.)

“Our top candidate for the position included workplace charging as a key factor when making his decision about the job offer. We now have a charging station, a new producer, and other employees have decided to purchase EVs too. You can't put a price on that!”

— *lynda.com*, Workplace Charging Challenge Partner

CREATING market pull



WORKPLACE CHARGING CHALLENGE

In support of *EV Everywhere*, DOE launched the Workplace Charging Challenge in January 2013. This new workplace-focused initiative calls upon U.S. employers in all sectors of the economy to provide PEV charging access at worksites across the country.

With the number of PEV drivers in the U.S. having more than doubled during 2013, there is an increased need for charging infrastructure. Though the primary charging site for most PEV owners today is at home, employers are starting to provide charging at the location where PEVs spend the greatest amount of time parked when away from home. In the first year of the Workplace Charging Challenge, more than 50 leading employers in the U.S. have pledged not only to provide PEV charging access to their workforce at more than 150 worksites, but also to share their best practices with other employers through a nationwide network of information exchange. The Challenge also enlists stakeholder organizations as “Ambassadors” to promote and facilitate workplace charging.

The workplace can serve as a unique environment where employees help each other discover the benefits of driving electric and learn about life as a PEV driver. In addition to providing technical assistance to employers throughout the development of their workplace charging programs, DOE and the



Ambassadors are committed to supporting employers’ ongoing efforts to foster PEV education.

Employers and employees alike are recognizing the benefits of workplace charging. For PEV drivers, the ability to charge at work can double the all-electric daily commuting range. Employers offering this benefit are signaling corporate leadership, enhancing corporate sustainability efforts, investing in their communities, and being recognized for those efforts.

Charging stations at the workplace can serve as a “second showroom” in which employees can learn about PEVs informally from their colleagues. *(Courtesy of Ford Motor Company, a Workplace Charging Challenge Partner.)*



U. S. Department of Energy

CLEAN CITIES SUPPORTS *EV EVERYWHERE*

Reaching true mass-market adoption of PEVs requires community preparedness in addition to technological advances. To foster this growth, DOE is supporting efforts to facilitate stakeholder collaboration, community planning, and training.



Clean Cities coalitions are helping to facilitate the deployment of alternative fuel vehicles including electric trucks. *(Courtesy of Clean Fuels Ohio.)*

Through 16 PEV readiness projects in 24 states, Clean Cities (DOE's alternative fuels deployment program) is working with communities across the country to increase market preparedness and facilitate planning among stakeholders. These communities now have the groundwork in place to establish codes, permitting, siting and design standards for PEV charging infrastructure. They are also informing the public about PEVs and are prepared to strategically place public charging

infrastructure based on local market analyses. Based on these local plans, DOE is preparing to publish a best practices summary guide to help other municipalities benefit from the project leaders' experiences.

To help these areas measure their progress and provide similar guidance to additional communities, the DOE has launched a PEV Readiness Scorecard. The scorecard asks a series of multiple-choice questions about a city's permitting, charging inspection processes, incentives, financing, public outreach, planning, and utility involvement. Based on these responses, the tool scores the municipality's efforts and offers recommendations for improvement. One hundred cities have already used this tool to assess and facilitate their progress toward being fully ready for mass adoption of PEVs. In the coming months, new features will enable this tool to provide recommendations and guidance to hundreds of additional communities across the nation.

PEV Community Readiness Scorecard

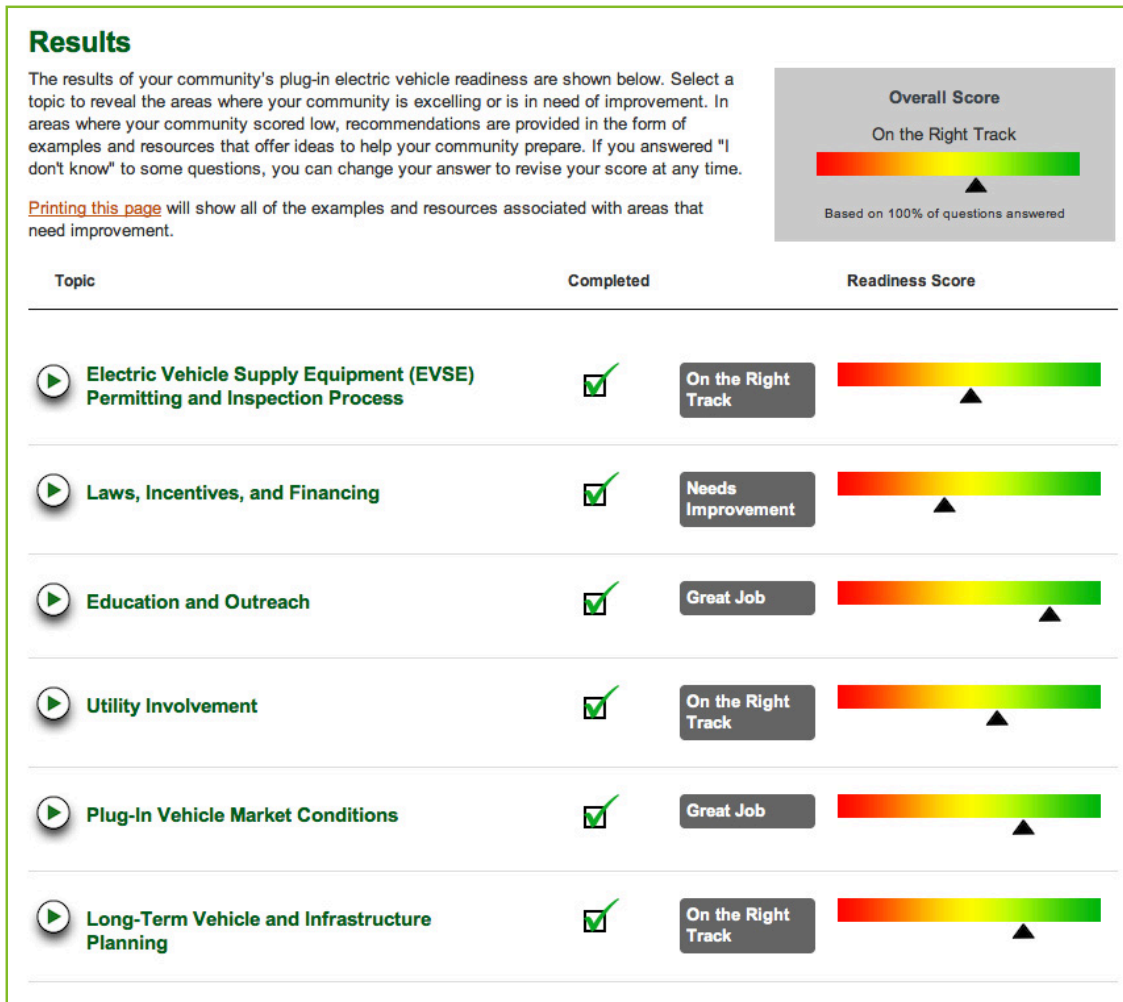

With the PEV Community Readiness Scorecard, city planners and sustainability managers can evaluate and facilitate their municipalities' progress toward being fully ready for mass adoption of PEVs.

TRAINING

DOE is also supporting training efforts to ensure our first responders and fleet mechanics are prepared to respond to PEV accidents and needed repairs. With support from DOE, the National Fire Protection Association is training police, firefighters, and emergency medical personnel on safely responding to accidents involving PEVs both in classrooms and online. Because first responders must use different procedures when approaching PEVs compared to conventional vehicles, providing this training is essential to guarantee the safety of both drivers and first responders. In addition, DOE is also collaborating with the National Alternative Fuels Training Consortium (NAFTC) and other community colleges to train thousands of fleet mechanics and other first responders across the nation via in-person and online sessions.

To develop the next generation of vehicle engineers and designers, DOE has partnered with seven universities to expand their graduate, undergraduate, and continuing education curriculums relevant to PEVs. With DOE's help, these top universities have developed new classes, programs of study, and innovative, hands-on tools that will prepare students to improve and develop future PEV technologies.



First responder PEV training at Ben Clark Training Center in Riverside, California, through DOE partner National Alternative Fuels Training Consortium.

TERMINOLOGY

Here's a guide to terms and abbreviations in this report:

- ▶ **All-electric vehicle (AEV):** a vehicle with plug-in capability whose driving energy comes entirely from its battery.
- ▶ **Plug-in hybrid electric vehicle (PHEV):** a vehicle with plug-in capability whose driving energy can come from either its battery or liquid fuel.
- ▶ **Plug-in electric vehicle (PEV):** any vehicle with plug-in capability. (An AEV or a PHEV.)
- ▶ **Hybrid electric vehicle (HEV):** a vehicle without plug-in capability but with an electric drive system and battery, whose driving energy comes only from liquid fuel.
- ▶ **Internal combustion engine vehicle (ICE):** a vehicle whose driving energy comes only from liquid fuel.

This report is being disseminated by the Department of Energy. As such, this document was prepared in compliance with Section 515 of the Treasury and General Government Appropriations Act for Fiscal Year 2001 (Public Law 106-554) and information quality guidelines issued by the Department of Energy. This document highlights work sponsored by agencies of the U.S. Government. Neither the U.S. Government nor any agency thereof, nor any of their employees, makes any warranty, express or implied, or assumes any legal liability or responsibility for the accuracy, completeness, or usefulness of any information, apparatus, product, or process disclosed, or represents that its use would not infringe privately owned rights. Reference herein to any specific commercial product, process, or service by trade name, trademark, manufacturer, or otherwise does not necessarily constitute or imply its endorsement, recommendation, or favoring by the U.S. Government or any agency thereof. The views and opinions of authors expressed herein do not necessarily state or reflect those of the U.S. Government or any agency thereof.

Publishing support services provided by Argonne National Laboratory.

A variety of DOE organizations and programs within the Office of Energy Efficiency and Renewable Energy collaborate to carry out the R&D and deployment activities in support of the *EV Everywhere* Grand Challenge. These partnerships help to remove technology and institutional barriers, enabling a faster transition of PEVs into the marketplace.

- ▶ **Office of Science** seeks to provide the foundations for new energy technologies to DOE's missions in energy, environment and national security. The Office of Science is the single largest supporter of basic research in the physical sciences in the United States. (<http://science.energy.gov/>)
- ▶ **ARPA-E** empowers America's energy researchers with funding, technical assistance and market readiness. ARPA-E funds energy technology projects that translate scientific discoveries and cutting-edge inventions into technological innovations. (<http://arpa-e.energy.gov/>)
- ▶ **EERE Vehicle Technologies Office** develops more energy efficient and environmentally friendly highway transportation technologies that enable America to use less petroleum. VTO aims to provide Americans with greater freedom of mobility and energy security, with lower costs and lower impacts on the environment. (<http://www.eere.energy.gov/>)